

Fuller Mid-Range Transmissions TRSM0160

October 2007

FS-5106A
FS-6206A



Powering Business Worldwide

BACKED BY
Roadranger
SUPPORT

For parts or service call us
Pro Gear & Transmission, Inc.



1 (877) 776-4600

(407) 872-1901

parts@eprogear.com

906 W. Gore St.

Orlando, FL 32805



WARNING

Before starting a vehicle always be seated in the drivers seat, place the transmission in neutral, set the parking brakes and disengage the clutch.

Before working on a vehicle place the transmission in neutral, set the parking brakes and block the wheels.

Before towing the vehicle place the transmission in neutral, and lift the rear wheels off the ground or disconnect the driveline to avoid damage to the transmission during towing.

cUT 8007k1/88

TABLE OF CONTENTS

FOREWORD

MODEL DESIGNATIONS AND SPECIFICATIONS

LUBRICATION

OPERATION

POWER FLOW

TORQUE RECOMMENDATIONS

PREVENTIVE MAINTENANCE

PRECAUTIONS

DISASSEMBLY

INSPECTION

REASSEMBLY

DISASSEMBLY AND REASSEMBLY—SHIFTING CONTROLS

GEARSHIFT LEVER HOUSING ASSEMBLY

SHIFT BAR HOUSING ASSEMBLY

REMOVAL—YOKE AND CLUTCH HOUSING

DISASSEMBLY—TRANSMISSION

REASSEMBLY—TRANSMISSION

INSTALLATION—CLUTCH HOUSING AND YOKE

INSTALLATION—SHIFTING CONTROLS

SHIFT BAR HOUSING ASSEMBLY

GEARSHIFT LEVER HOUSING ASSEMBLY

FOREWORD

This manual is designed to provide detailed information necessary to service and repair the Fuller® Transmission listed on the cover.

As outlined in the Table of Contents, the manual is divided into 3 main sections:

- a. Technical information and reference
- b. Removal, disassembly, reassembly and installation
- c. Options

The format of the manual is designed to be followed in its entirety if complete disassembly and reassembly of the transmission is necessary. But if only one component of the transmission needs to be repaired, refer to the Table of Contents for the page numbers showing that component. For example, if you need to work on the Shift Bar Housing, you will find instructions for removal, disassembly and reassembly on page 18. Instructions for installation are on page 53. Service Manuals, Illustrated Parts Lists, Drivers Instructions, and other forms of product

service information for these and other Fuller Transmissions are available upon request. A Technical Literature Order Form may be found in the back of this manual. You may also obtain Service Bulletins, detailing information on product improvements, repair procedures and other service-related subjects by writing to the following address:

EATON CORPORATION
TRANSMISSION DIVISION
Technical Service Department
PO. Box 4013
Kalamazoo, Michigan 49003
(616) 342-3344

Every effort has been made to ensure the accuracy of all information in this brochure. However, **Eaton Transmission Division makes no expressed or implied warranty or representation based on the enclosed information.** Any errors or omissions may be reported to Training and Publications, Eaton Transmission Division, PO, Box 4013, Kalamazoo, MI 49003,

MODEL DESIGNATIONS AND SPECIFICATIONS

Nomenclature:

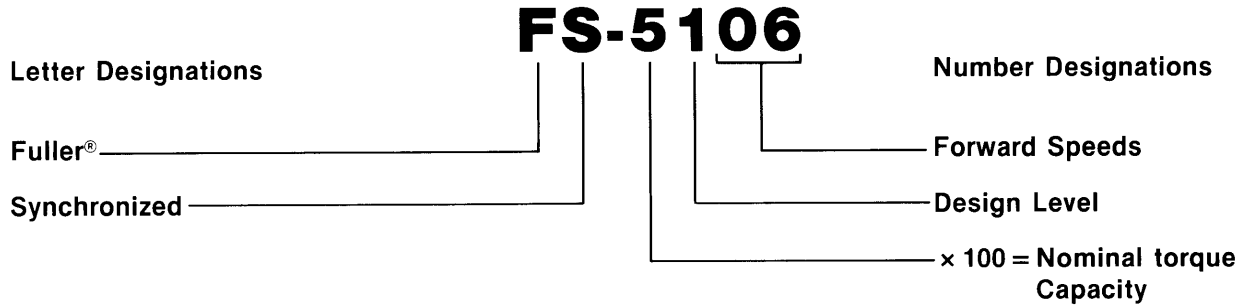

IMPORTANT: All Fuller Transmissions are identified by model and serial number. This information is stamped on the transmission identification tag and affixed to the case.
DO NOT REMOVE OR DESTROY THE TRANSMISSION IDENTIFICATION TAG.

Specifications:

Model	No Speeds	Gear Ratios							Relative Speed PTO Gear to Input R.P.M.		Note 1 Length in. (mm)	Note 2 Weight Lbs. (Kg)	Note 3 011 Capacity Pints (Liters)
		1st	2nd	3rd	4th	5th	6th	Reverse	Left	Right			
FS-5106	6	9.01	5.271	3.250	2.040	1.362	1.000	8.625	.522	522	25.56 (649)	358 (162)	(8.52)
FS-6206	6	9.01	5.271	3.250	2.040	1.362	1.000	8.625	.522	522	25.56 (649)	358 (162)	(8.52)

See Chart Notes.

CHART NOTES:

1. Lengths measured from face of clutch housing to center line of yoke.
2. Weights include shift bar housing and end yoke, less clutch housing, tower assembly and clutch release parts. For more information on available clutch housings, refer to publication FUL-140 - "Clutch Housing Chart." All weights are approximate.
3. Oil capacities are approximate, depending on inclination of engine and transmission. Always fill transmission with proper grade and type of lubricant to level of filler opening. See LUBRICATION.

LUBRICATION

Proper Lubrication . . . the Key to long transmission life

Proper lubrication procedures are the key to a good all-around maintenance program. If the oil is not doing its job, or if the oil level is ignored, all the maintenance procedures in the world are not going to keep the transmission running or assure long transmission life.

Eaton® Fuller® Transmissions are designed so that the internal parts operate in a bath of oil circulated by the motion of gears and shafts.

Thus, all parts will be amply lubricated if these procedures are closely followed:

1. Maintain oil level. Inspect regularly.
2. Change oil regularly.
3. Use the correct grade and type of oil.
4. Buy from a reputable dealer.

Lubrication Change and Inspection

Eaton® Roadranger® CD50 Transmission Fluid	
HIGHWAY USE—Heavy Duty and Mid-Range	
First 3,000 to 5,000 miles (4827 to 8045 Km)	Factory fill Initial drain,
Every 10,000 miles (16090 Km)	Check fluid level. Check for leaks.
Heavy Duty Highway Change Interval	
Every 250,000 miles (402336 Km)	Change transmission fluid.
Mid-Range Highway Change Interval	
Every 100,000 miles (160,000 Km) or every 3 years whichever occurs first.	Change transmission fluid.
OFF-HIGHWAY USE	
First 30 hours	Factory fill initial drain,
Every 40 hours	Inspect fluid level. Check for leaks.
Every 500 hours	Change transmission fluid where severe dirt conditions exist.
Every 1,000 hours	Change transmission fluid (Normal off-highway use).
Heavy Duty Engine Lubricant or Mineral Gear Lubricant	
HIGHWAY USE	
First 3,000 to 5,000 miles (4827 to 8045 Km)	Factory fill initial drain.
Every 10,000 miles (16090 Km)	Inspect lubricant level. Check for leaks.
Every 50,000 miles (80450 Km)	Change transmission lubricant.
OFF-HIGHWAY USE	
First 30 hours	Change transmission lubricant on new units.
Every 40 hours	Inspect lubricant level. Check for leaks.
Every 500 hours	Change transmission lubricant where severe dirt conditions exist.
Every 1,000 hours	Change transmission lubricant (Normal off-highway use).

Change the oil filter when fluid or lubricant is changed.

Recommended Lubricants		
Type	Grade (SAE)	Fahrenheit (Celsius) Ambient Temperature
Eaton® Roadranger® CD50 Transmission Fluid	50	All
Heavy Duty Engine Oil		
MIL-L-2104B, C or D or	50	Above 10°F(-12°C.)
API-SF or API-CD	40	Above 10°F(-12°C.)
(Previous API designations acceptable)	30	Below 10°F(-12°C.)
Mineral Gear Oil with rust and oxidation Inhibitor	90 80W	Above 10°F(-12°C) Below 10 °F(-12°C)
API-GL-1		

The use of mild EP gear oil or multi-purpose gear oil is not recommended, but if these gear oils are used, be sure to adhere to the following limitations:

Do not use mild EP gear oil or multi-purpose gear oil when operating temperatures are above 230°F (110°C). Many of these gear oils, particularly 85W140, break down above 230°F and coat seals, bearings and gears with deposits that may cause premature failures. If these deposits are observed (especially a coating on seal areas causing oil leakage), change to Eaton Roadranger CD50 transmission fluid, heavy duty engine oil or mineral gear oil to assure maximum component life and to maintain your warranty with Eaton. (Also see "Operating Temperatures".)

Additives and friction modifiers are not recommended for use in Eaton Fuller transmissions.

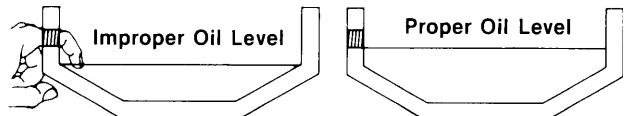

Proper Oil Level

Make sure oil is level with filler opening. Because you can reach oil with your finger does not mean oil is at proper level. **One inch of oil level is about one gallon of oil.**

Draining Oil

Drain transmission while oil is warm. To drain oil remove the drain plug at bottom of case. Clean the drain plug before re-installing.

Refilling

Clean case around filler plug and remove plug from side of case. Fill transmission to the level of the filler opening. If transmission has two filler openings, fill to level of both openings.

The exact amount of oil will depend on the transmission inclination and model. Do not over fill—this will cause oil to be forced out of the transmission.

When adding oil, types and brands of oil should not be mixed because of possible incompatibility.

LUBRICATION

Operating Temperatures —With Eaton® Roadranger® CD50 Transmission Fluid Heavy Duty Engine Oil and Mineral Oil

The transmission should not be operated consistently at temperatures above 250°F (120°C). However, intermittent operating temperatures to 300°F (149°C) will not harm the transmission. Operating temperatures above 250°F increase the lubricant's rate of oxidation and shorten its effective life. When the average operating temperature is above 250°F, the transmission may require more frequent oil changes or external cooling.

The following conditions in any combination can cause operating temperatures of over 250°F: (1) operating consistently at slow speeds, (2) high ambient temperatures, (3) restricted air flow around transmission, (4) exhaust system too close to transmission, (5) high horsepower, overdrive operation.

External oil coolers are available to reduce operating temperatures when the above conditions are encountered.

Transmission Oil Coolers are:

Recommended

- With engines of 350 H.P. and above with overdrive transmissions

Required

- With engines 399 H.P. and above with overdrive transmissions and GCW'S over 90,000 lbs.
- With engines 399 H.P. and above and 1400 Lbs.-Ft. or greater torque
- With engines 450 H.P. and above

— With EP or Multipurpose Gear Oil

Mild EP gear oil and multipurpose gear oil are not recommended when lubricant operating temperatures are above 230°F (110°C). In addition, transmission oil coolers are not recommended with these gear oils since the oil cooler materials may be attacked by these gear oils. The lower temperature limit and oil cooler restriction with these gear oils generally limit their success to milder applications.

Proper Lubrication Levels as Related to Transmission Installation Angles

If the transmission operating angle is more than 12 degrees, improper lubrication can occur. The operating angle is the transmission mounting angle in the chassis plus the percent of upgrade (expressed in degrees).

The chart below illustrates the safe percent of upgrade on which the transmission can be used with various chassis mounting angles. For example: if you have a 4 degree transmission mounting angle, then 8 degrees (or 14 percent of grade) is equal to the limit of 12 degrees. If you have a 0 degree mounting angle, the transmission can be operated on a 12 degree (21 percent) grade.

Anytime the transmission operating angle of 12 degrees is exceeded for an extended period of time the transmission should be equipped with an oil pump or cooler kit to insure proper lubrication.

Note on the chart the effect low oil levels can have on safe operating angles. Allowing the oil level to fall 1/2" below the filler plug hole reduces the degree of grade by approximately 3 degrees (5.5 percent).

Proper Lubrication Levels are Essential!

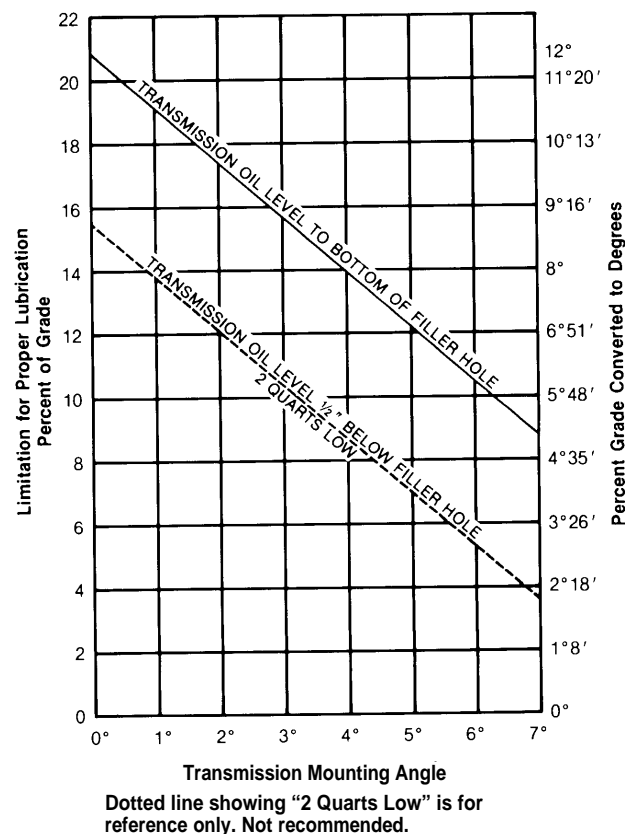

OPERATION

Gear Shift Lever Pattern and Shifting Instructions

Follow the simple 6-speed shift pattern . . .

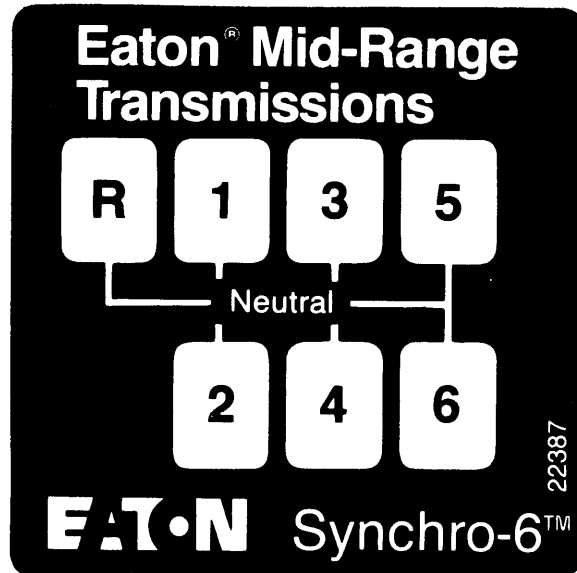

General Information

These transmissions have six forward speeds and one reverse, and are shifted as you would shift any synchronized manual transmission, following the simple 6-speed shift pattern.

Driving Tips

- Ž Always use the clutch when making upshifts or downshifts. Premature synchronizer failure can result from not using the clutch.
- Always select a starting gear that will provide sufficient reduction for the load and terrain.
- Never downshift at too high of a road speed.
- Never slam or jerk the shift lever to complete gear engagement.
- Never coast with the transmission in neutral and the clutch dis-engaged.

POWER FLOW

The transmission must efficiently transfer the engine's power, in terms of torque, to the vehicle's rear wheels. Knowledge of what takes place in the transmission during torque transfer is essential when trouble-shooting and making repairs becomes necessary.

1. Power (torque) from the engine is transferred to the input shaft and drive gear.
2. Torque is transferred to countershaft drive gear.
3. Torque is delivered along countershaft to all countershaft gears.
4. Torque is transferred to "engaged" mainshaft gear. The cross section illustrates 1st speed gear position.
5. Internal clutching teeth of engaged mainshaft gear transfers torque to mainshaft through synchronizer assembly.
6. Mainshaft transfers torque directly to driveshaft through rear yoke.

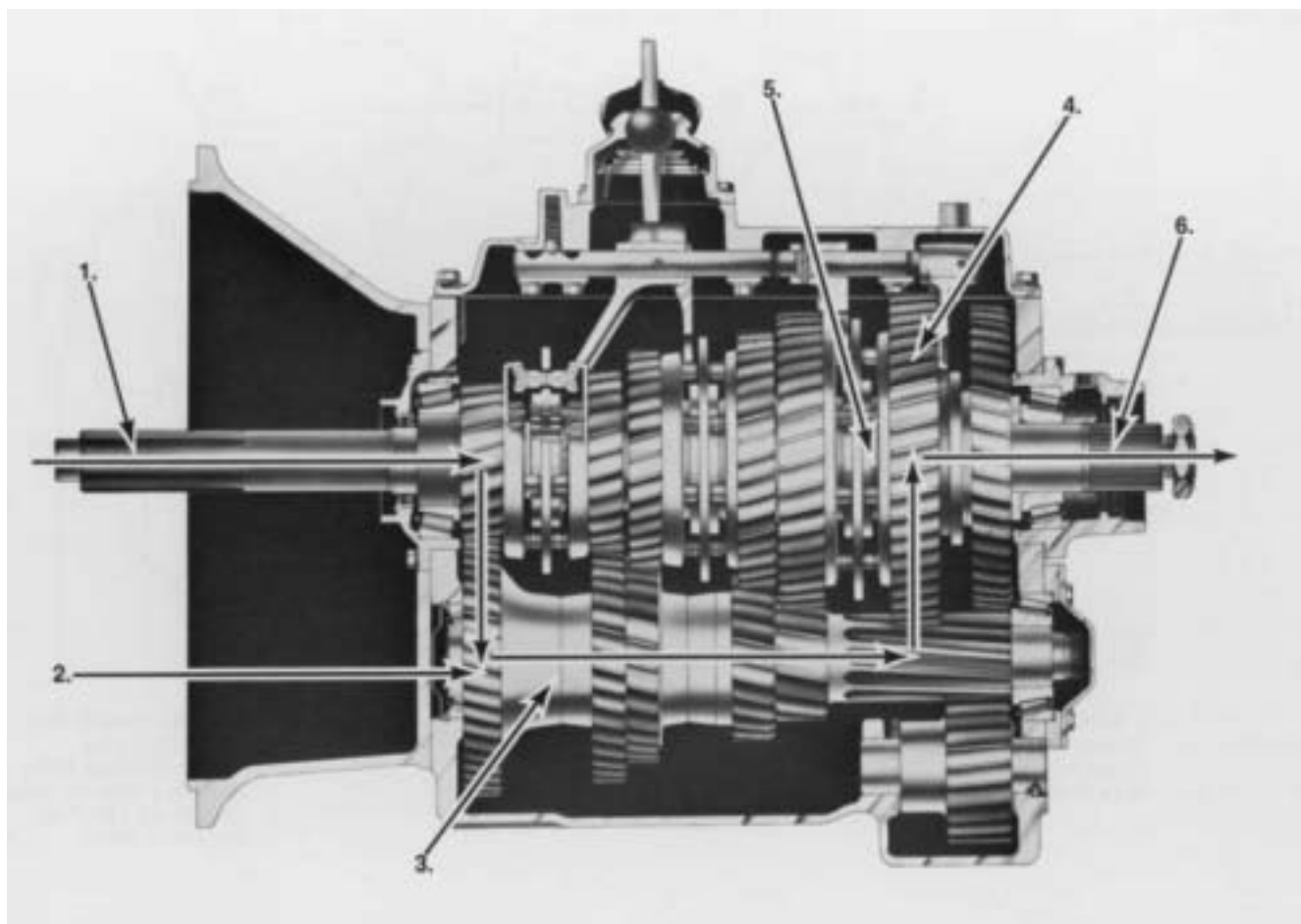

TORQUE RECOMMENDATIONS

Correct torque application is important to assure long transmission life, Over or under tightening of fasteners can result in a loose installation and, in many instances, can eventually cause damage to the transmission. Use a torque wrench to obtain recommended torque ratings. Do not torque capscrews dry.

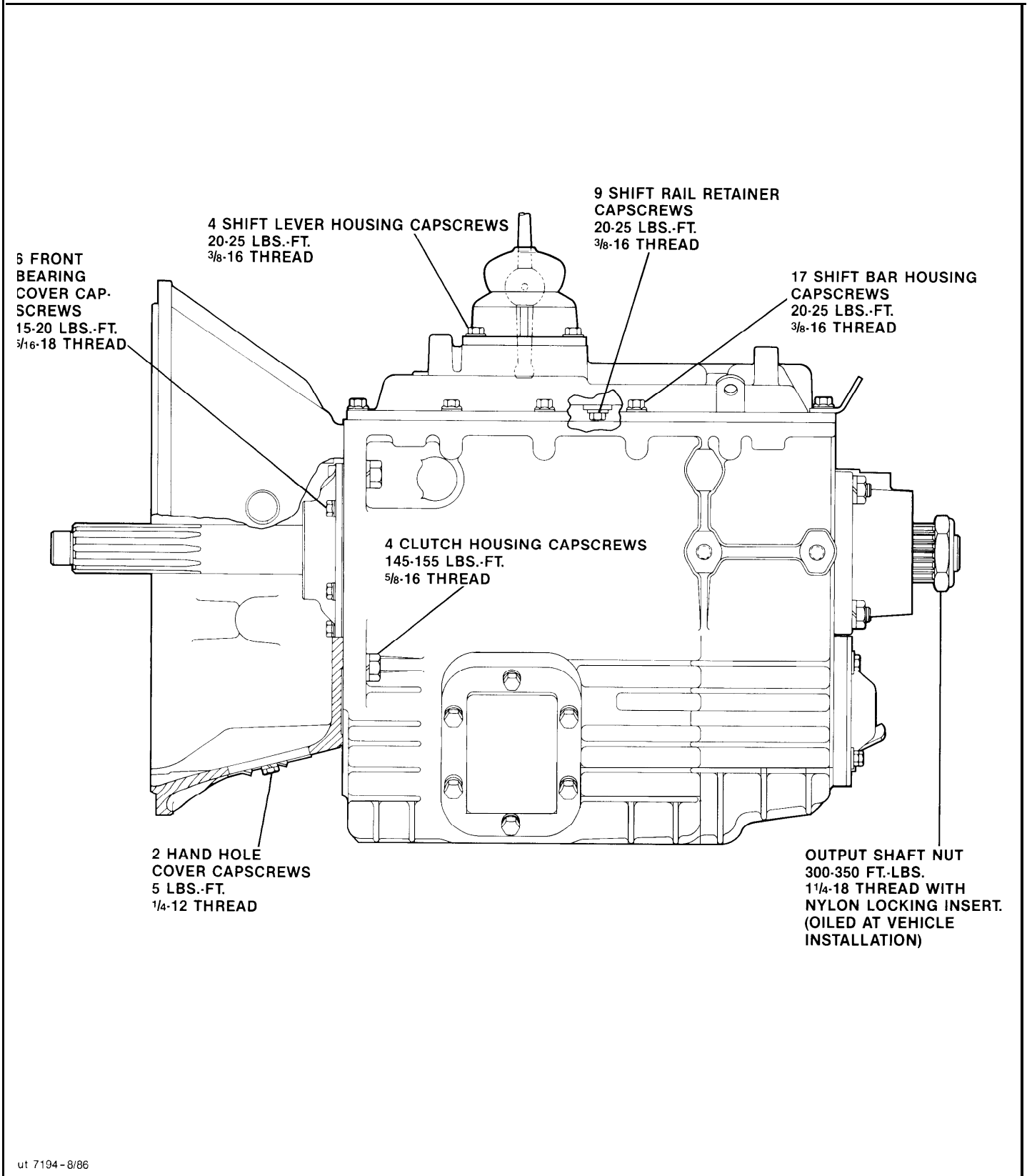

TORQUE RECOMMENDATIONS

4 MAINSHAFT REAR BEARING
COVER NUTS
60-70 LBS.-FT.
1/2-32 THREAD
USE LOCKWASHERS

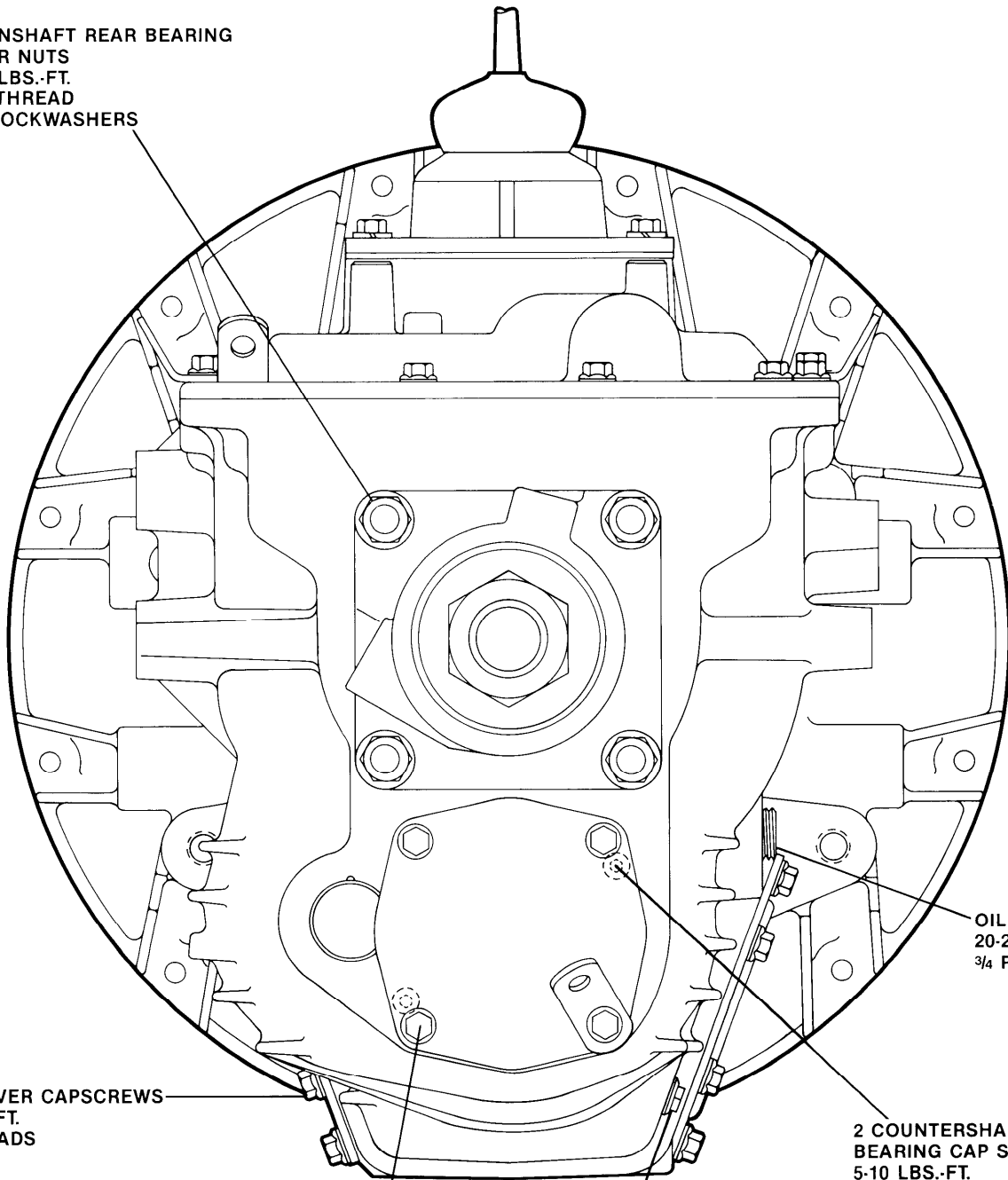

OIL FILL PLUG
20-25 LBS.-FT.
3/4 PIPE THREAD

12 PTO COVER CAPSCREWS
10-15 LBS.-FT.
3/8-16 THREADS

2 COUNTERSHAFT REAR
BEARING CAP SETSCREWS
5-10 LBS.-FT.
1/4 THREAD

4 COUNTERSHAFT REAR BEARING
COVER CAPSCREWS
20-30 LBS.-FT.
3/8-16 THREAD
USE PLAIN FLAT WASHERS

OIL DRAIN PLUG
20-25 LBS.-FT.
3/4 PIPE THREAD

NOTE: APPLY LOCTITE 262 TO THREADS OF
ALL CAPSCREWS BEFORE INSTALLING

PREVENTIVE MAINTENANCE

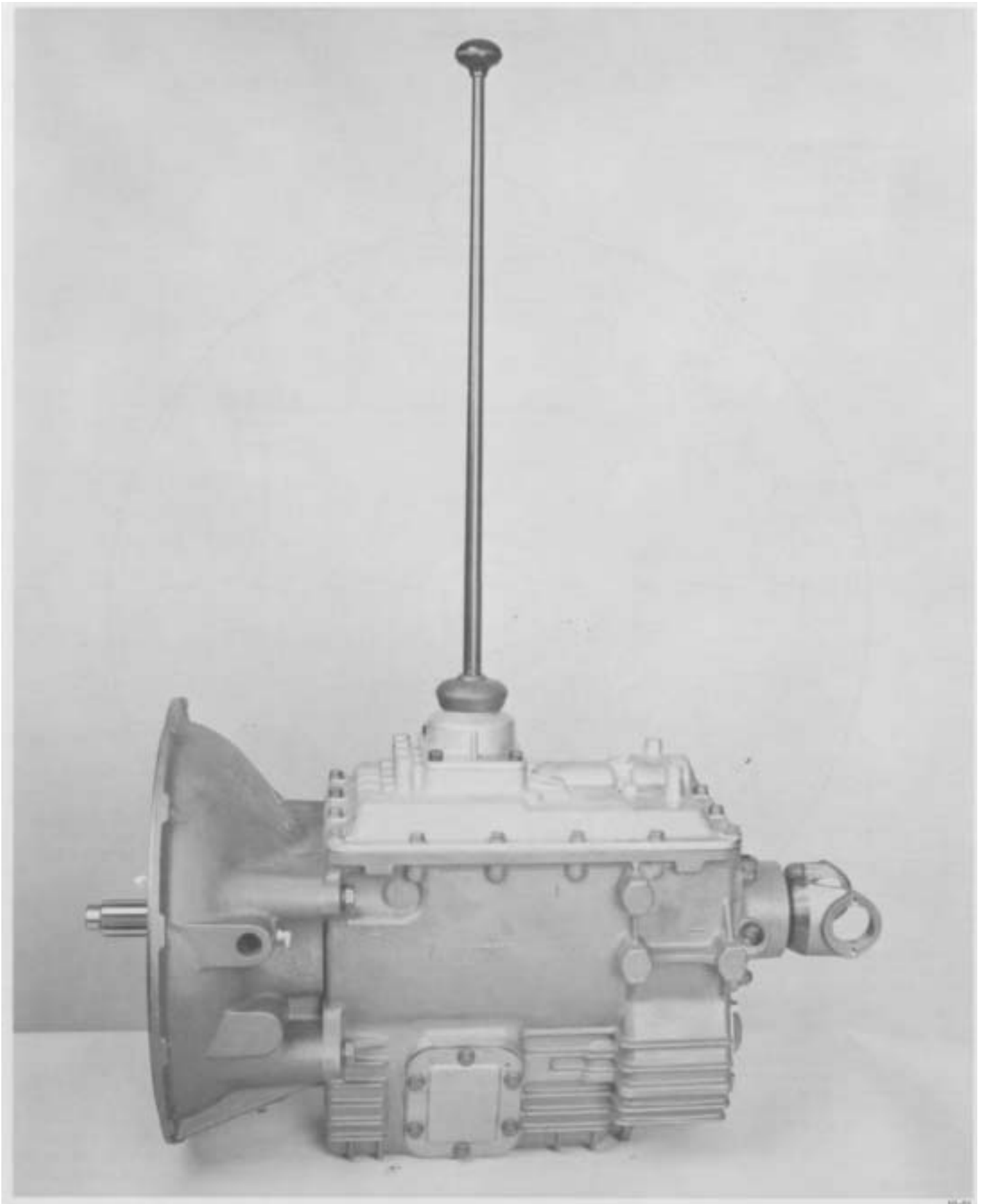

PREVENTIVE MAINTENANCE

PREVENTIVE MAINTENANCE CHECK CHART

CHECKS WITHOUT PARTIAL DISASSEMBLY OF CHASSIS OR CAB

- 1. Clutch Housing Mounting**
 - a. Check all capscrews of clutch housing flange for looseness.
- 2. Clutch Release Bearing (Not Shown)**
 - a. Remove hand hole cover and check radial and axial clearance in release bearing.
 - b. Check relative position of thrust surface of release bearing with thrust sleeve on push-type clutches.
- 3. Clutch Pedal Shaft and Bores**
 - a. Pry upward on shafts to check wear.
 - b. If excessive movement is found, remove clutch release mechanism and check bushings in bores and wear on shafts.
- 4. Lubricant**
 - a. Change at specified service intervals.
 - b. Use only the types and grades as recommended. See LUBRICATION.
- 5. Filler and Drain Plugs**
 - a. Remove filler plug and check level of lubricant at specified intervals. Tighten filler and drain plugs securely.
- 6. Capscrews and Gaskets**
 - a. Check all capscrews, especially those on PTO covers and rear bearing covers for looseness which would cause oil leakage. See TORQUE RECOMMENDATIONS.
 - b. Check PTO opening and rear bearing covers for oil leakage due to faulty gasket.
- 7. Gear Shift Lever**
 - a. Check for looseness and free play in housing. If lever is loose in housing, proceed with Check No. 8.

8. Gear Shift Lever Housing Assembly

- a. Remove the gear shift lever housing assembly from transmission.
- b. Check tension spring and washer for set and wear.
- c. Check bottom end of gear shift lever for wear of slots. Also check for wear of finger assembly.

CHECKS WITH DRIVE LINE DROPPED

9. Universal Joint Companion Flange or Yoke Nut

- a. Check for tightness. Tighten to recommended torque.

10. Output Shaft (Not Shown)

- a. Pry upward against output shaft to check radial clearance in mainshaft rear bearing.

CHECKS WITH UNIVERSAL JOINT COMPANION FLANGE OR YOKE REMOVED

NOTE: If necessary, use solvent and shop rag to clean sealing surface of companion flange or yoke. DO NOT USE CROCUS CLOTH, EMERY PAPER OR OTHER ABRASIVE MATERIALS THAT WILL MAR SURFACE FINISH.

11. Splines on Output Shaft (Not Shown)

- a. Check for wear from movement and chucking action of the universal joint companion flange or yoke.

12. Mainshaft Rear Bearing Cover

- a. Check oil seal for wear.

PRECAUTIONS

Disassembly

It is assumed in the detailed assembly instructions that the lubricant has been drained from transmission, the necessary linkage disconnected and the transmission has been removed from vehicle chassis. Removal of the gear shift lever housing assembly is included in the detailed instructions (Disassembly and Reassembly—Shifting Controls); however, this assembly must be detached from shift bar housing before transmission can be removed.

FOLLOW CLOSELY EACH PROCEDURE IN THE DETAILED INSTRUCTIONS, MAKING USE OF THE TEXT, ILLUSTRATIONS AND PHOTOGRAPHS PROVIDED.

- 1. BEARINGS** — Carefully wash and relubricate all reusable bearings as removed and protectively wrap until ready for use. Remove bearings planned to be reused with pullers designed for this purpose.
- 2. ASSEMBLIES** — When disassembling the various assemblies, such as the mainshaft, countershafts, and shift bar housing, lay all parts on a clean bench in the same sequence as removed. This procedure will simplify reassembly and reduce the possibility of losing parts.
- 3. SNAP RINGS** — Remove snap rings with pliers designed for this purpose. Snap rings removed in this manner can be reused, if they are not sprung or loose.
- 4. CLEANLINESS** — Provide a clean place to work. It is important that no dirt or foreign material enters the unit during repairs. Dirt is an abrasive and can damage bearings. It is always good practice to clean the outside of the unit before starting the planned disassembly.
- 5. WHEN USING TOOLS TO MOVE PARTS** — Always apply force to shafts, housings, etc, with restraint. Movement of some parts is restricted. Never apply force to the part being driven after it stops solidly. The use of soft hammers, bars and mauls for all disassembly work is recommended.

Inspection

Before reassembling the transmission, check each part carefully for abnormal or excessive wear and damage to determine reuse or replacement. When replacement is necessary, use only genuine Fuller Transmission parts to assure continued performance and extended life from your unit.

Since the cost of a new part is generally a small fraction of the total cost of downtime and labor, avoid reusing a questionable part which could lead to additional repairs and expense soon after initial reassembly. To aid in determining the reuse or replacement of any transmission part, consideration should also be given to the unit's history, mileage, application, etc.

Recommended inspection procedures are provided in the following checklist.

A. BEARINGS

1. Wash all bearings in clean solvent. Check balls, rollers and raceways for pitting, discoloration, and spalled areas. Replace bearings that are pitted, discolored, spalled, or damaged during disassembly.
2. Lubricate bearings that are not pitted, discolored, or spalled and check for axial and radial clearances.
Replace bearings with excessive clearances.
3. Check bearing fits. Bearing inner races should be tight to shaft; outer races slightly tight to slightly loose in case bore. If bearing spins freely in bore, however, case should be replaced.

B. GEARS

1. Check gear teeth for frosting and pitting. Frosting of gear tooth faces present no threat of transmission failure. Often in continued operation of the unit, frosted gears will "heal" and not progress to the pitting stage. In most cases, gears with light to moderate pitted teeth have considerable gear life remaining and can be reused, but gears with advanced stage pitting should be replaced.
2. Check for gears with clutching teeth abnormally worn, tapered, or reduced in length from clashing in shifting. Replace gears found in any of these conditions.

PRECAUTIONS

Inspection (cont'd.)

3. Check axial clearance of gears. Where excessive clearance is found, check gear snap ring, split washer, clutch hub, and gear hub for excessive wear.

C. SPLINES

1. Check splines on all shafts for abnormal wear. If sliding clutch gears, companion flange, or clutch hub have worn into the sides of the splines, replace the specific shaft affected.

D. SPLIT WASHERS

1. Check surfaces of all washers. Washers scored or reduced in thickness should be replaced.

E. REVERSE IDLER GEAR ASSEMBLIES

1. Check for excessive wear from action of roller bearings.

F. GRAY IRON PARTS

1. Check all gray iron parts for cracks and breaks. Replace or repair parts found to be damaged. Heavy castings may be welded or brazed provided the cracks do not extend into bearing bores or bolting surfaces. When welding, however, never place the ground so as to allow current to pass through the transmission.

G. CLUTCH RELEASE PARTS

1. Check clutch release parts. Replace yokes worn at cam surfaces and bearing carrier worn at contact pads.
2. Check pedal shafts. Replace those worn at bushing surfaces.

H. SHIFT BAR HOUSING ASSEMBLY

1. Check for wear on shift yokes and finger assembly at pads and lever slot. Replace excessively worn parts.
2. Check yokes for correct alignment. Replace sprung yokes.
3. Check lockscrews in yoke assembly retainer plates. Tighten those found loose.

1. GEAR SHIFT LEVER HOUSING ASSEMBLY

1. Check spring tension on shift lever. Replace tension spring if lever moves too freely.
2. If housing is disassembled, check bottom end of gear shift lever and shift finger assembly for wear. Replace both parts if excessively worn.

J. BEARING COVERS

1. Check covers for wear from thrust of adjacent bearing. Replace covers damaged from thrust of bearing outer race.
2. Check bores of covers for wear. Replace those worn oversize.

K. OIL SEALS

1. Check oil seal in input shaft and rear bearing cover. If sealing action of lip has been destroyed, replace seal.

L. CLUTCHING TEETH

1. Check all shift yokes and yoke slots in sliding clutches for extreme wear or discoloration from heat.
2. Check engaging teeth of sliding clutches for partial engagement pattern.

M. SYNCHRONIZER ASSEMBLY

1. Check synchronizer for burrs, uneven and excessive wear at contact surface, and metal particles.
2. Check blocker pins for excessive wear or looseness.
3. Check synchronizer contact surfaces on the synchronizer cups for wear.

PRECAUTIONS

Reassembly

Make sure that interiors of case and housings are clean. It is important that dirt and other foreign materials be kept out of the transmission during reassembly. Dirt is an abrasive and can damage polished surfaces of bearings and washers. Use certain precautions, as listed below, during reassembly.

1. **GASKETS** — Use new gaskets throughout the transmission as it is being rebuilt. Make sure all gaskets are installed. An omission of any gasket can result in oil leakage or misalignment of bearing covers. Install PTO and shift bar housing gaskets dry.
2. **CAPSCREWS** — TO prevent oil leakage and loosening, use Loctite 262 thread sealant on all cap-screws. For torque ratings, see TORQUE RECOMMENDATIONS.
3. **SHIMS** — Apply a light coat of Loctite 510 to both sides of shims before final installation to prevent leakage.
4. **ASSEMBLY** — Refer to the illustrations provided in the detailed disassembly instructions as a guide to reassembly.
5. **INITIAL LUBRICATION** — Coat all thrust washers, synchronizers, and bearings with transmission lubricant during reassembly to prevent damage during initial start up.
6. **END PLAY** — Maintain .006 -.010 end play on countershaft and mainshaft assemblies.
7. **BEARINGS** — Use of a sleeve type driver that contacts the inner race of the bearing is recommended to prevent damage to the rollers and cage.
8. **UNIVERSAL JOINT COMPANION FLANGE OR YOKE** — Pull the companion flange or yoke into place with the output shaft nut, using 300-350 foot-pounds (407-475 N.m) of torque. Make sure the speedometer drive gear or a replacement spacer has been installed. Failure to properly torque the nut can result in damage to the mainshaft rear bearing.

IMPORTANT: REFER TO THE APPROPRIATE ILLUSTRATED PARTS LIST (SPECIFIED BY MODEL SERIES) TO ENSURE THAT PROPER PARTS ARE USED DURING REASSEMBLY OF THE TRANSMISSION.

DISASSEMBLY AND REASSEMBLY SHIFTING CONTROLS

GEARSHIFT LEVER HOUSING ASSEMBLY

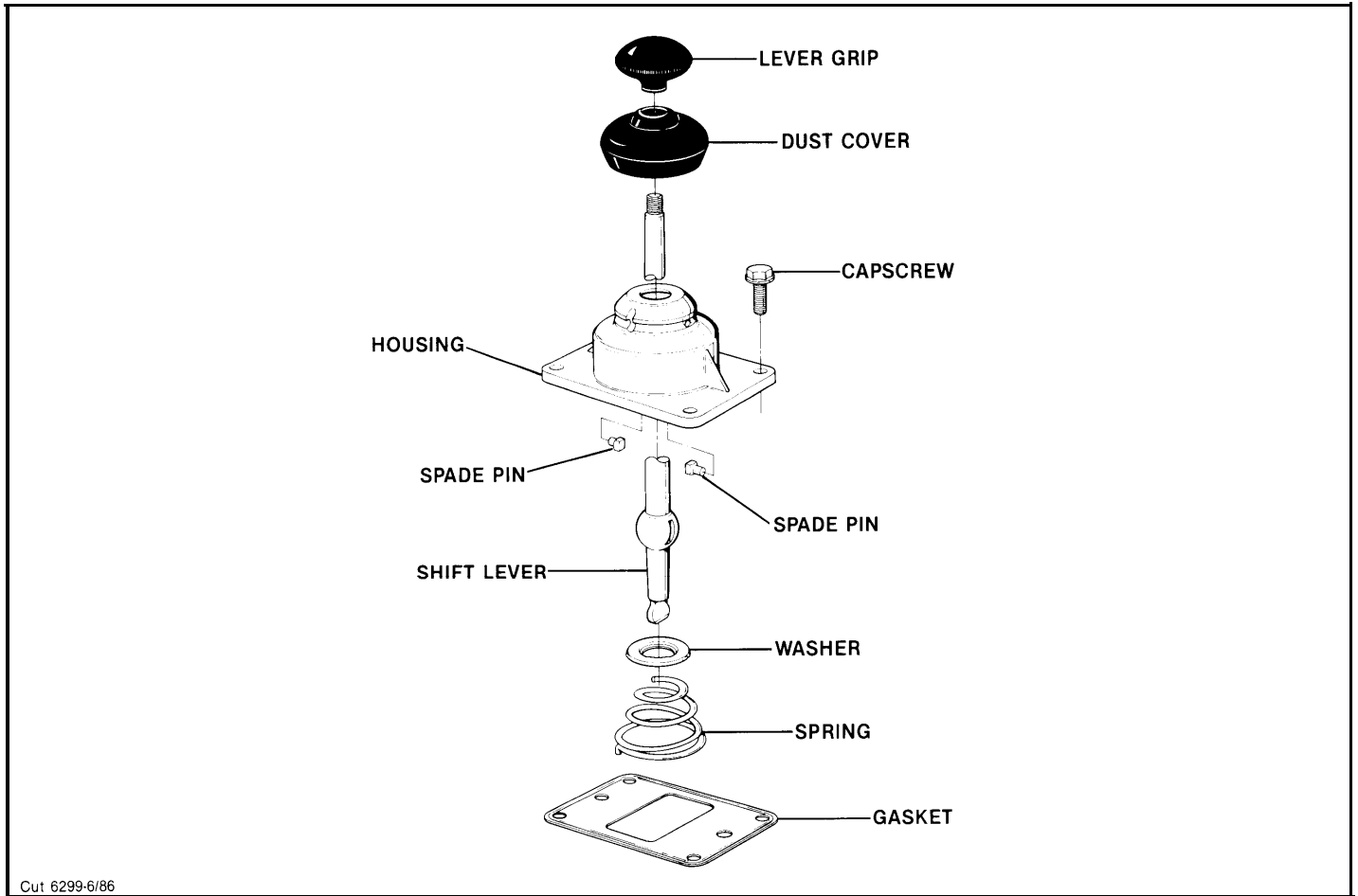

A. Removal and Disassembly

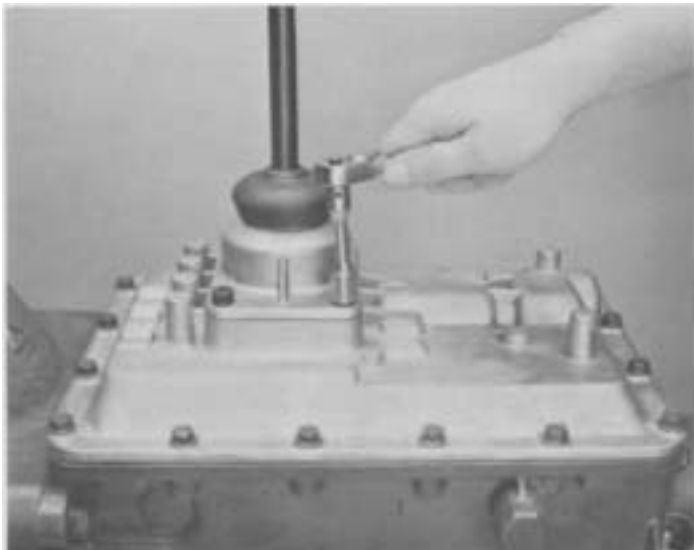

1. Turn out four cap screws and remove tower assembly and gasket from shift bar housing.

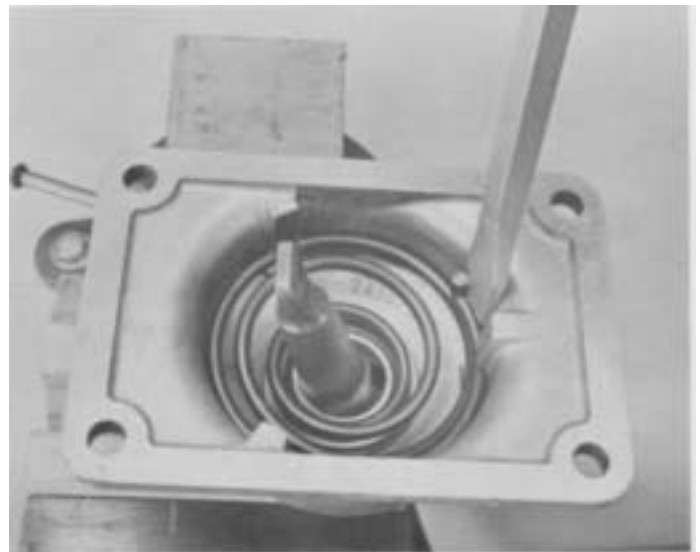

2. Remove shift lever grip and boot from shift lever, secure assembly in vise with bottom of housing up. Use a large screwdriver to twist between spring and housing, forcing spring from under lugs in housing. Do one coil at a time.

DISASSEMBLY AND REASSEMBLY SHIFTING CONTROLS

GEARSHIFT LEVER HOUSING ASSEMBLY (con't.)



3. Remove tension spring, washer and gearshift lever from housing.

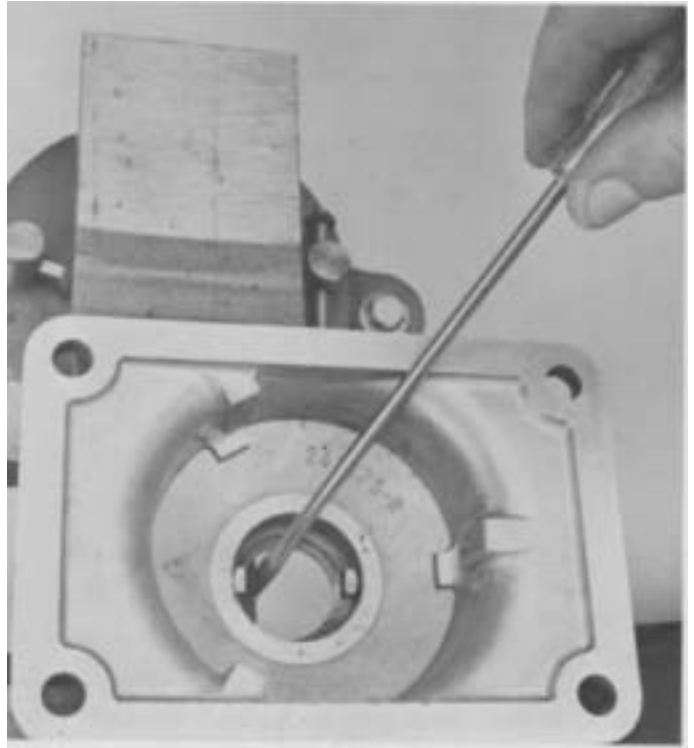

4. Remove spade pins from bore in housing.

16-04

B. Reassembly of Gearshift Lever Housing Assembly

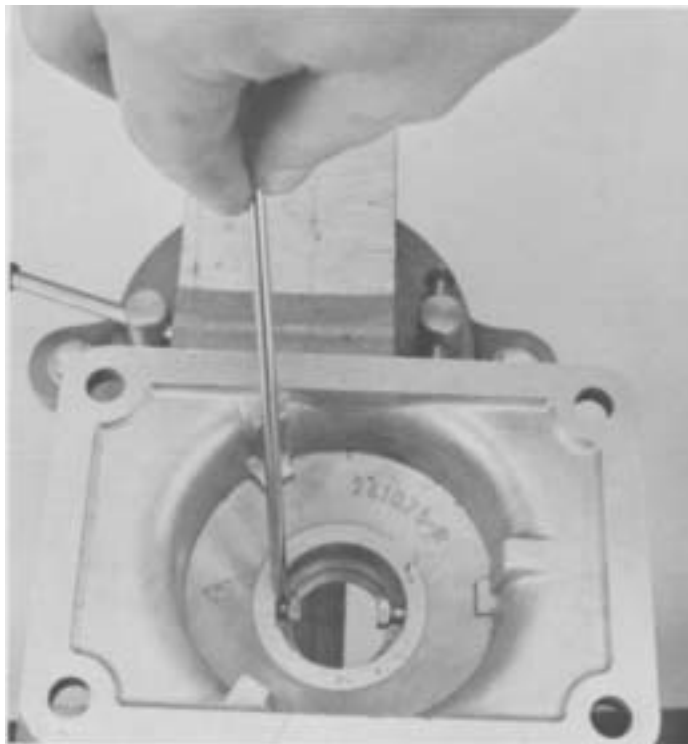

1. With gearshift lever housing secured in vise as during disassembly, install spade pins in bore of housing.

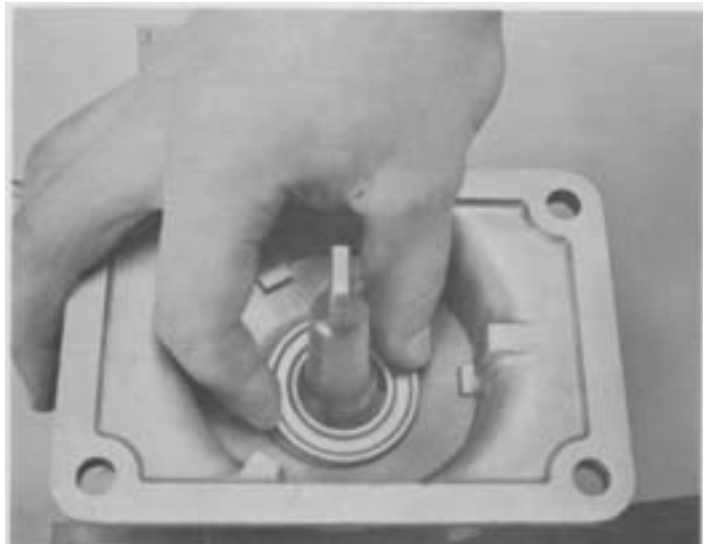

2. Position gearshift lever in housing with spade pins in lever ball slot and install tension spring washer over ball, dished side up.

16-02

DISASSEMBLY AND REASSEMBLY SHIFTING CONTROLS

GEARSHIFT LEVER HOUSING ASSEMBLY (con't.)

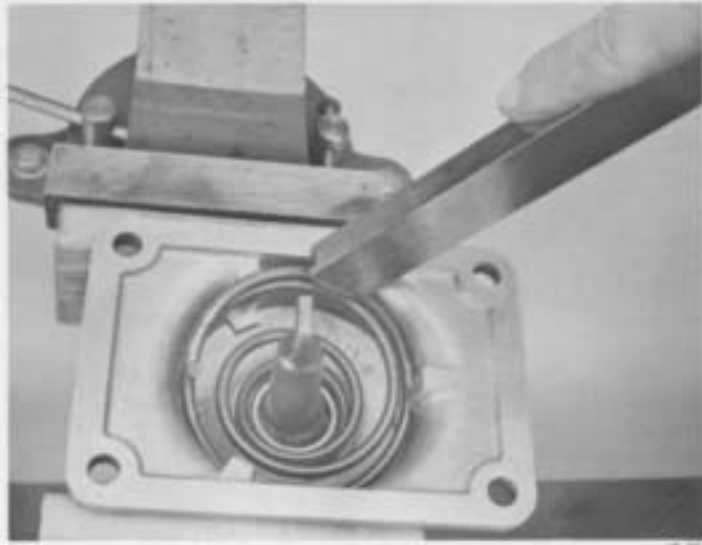

3. Install tension spring under lugs in housing, seating one coil at a time. Use of a spring driving tool is recommended.



4. Remove assembly from vise and install rubber boot over gearshift lever and against housing. Install shift lever grip.

DISASSEMBLY AND REASSEMBLY SHIFTING CONTROLS

SHIFT BAR HOUSING ASSEMBLY

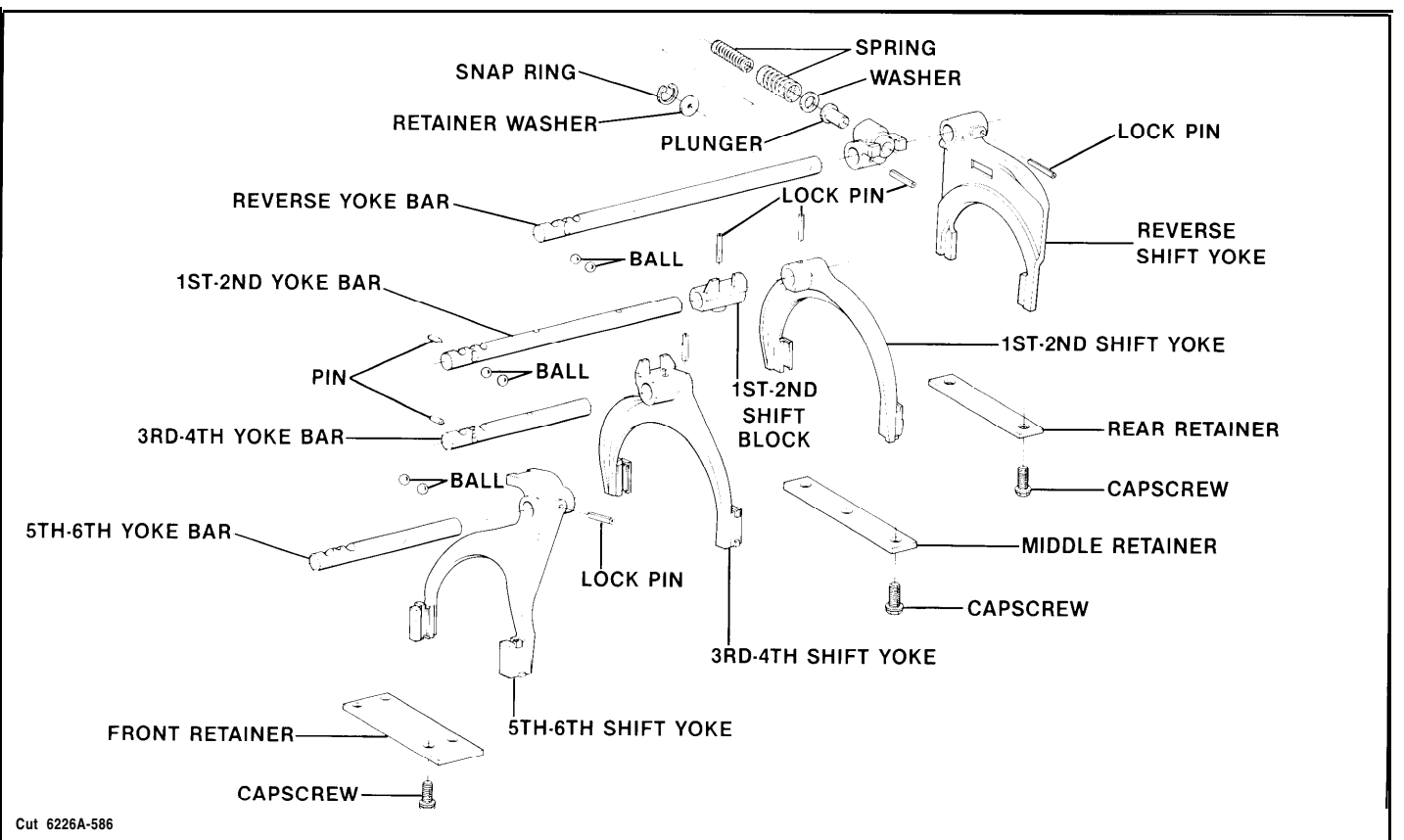
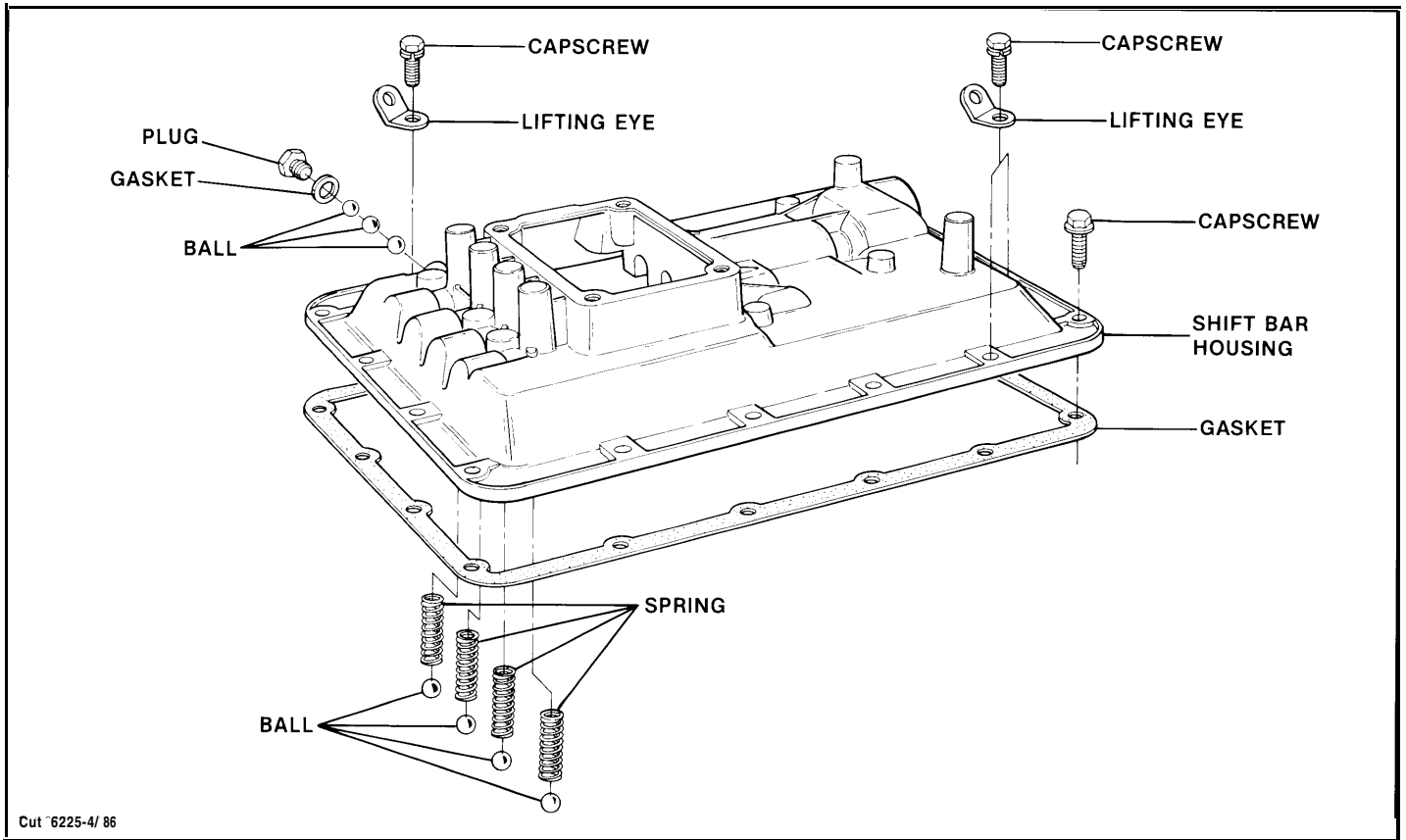

DISASSEMBLY AND REASSEMBLY SHIFTING CONTROLS

SHIFT BAR HOUSING ASSEMBLY (con't.)

A. Removal and Disassembly

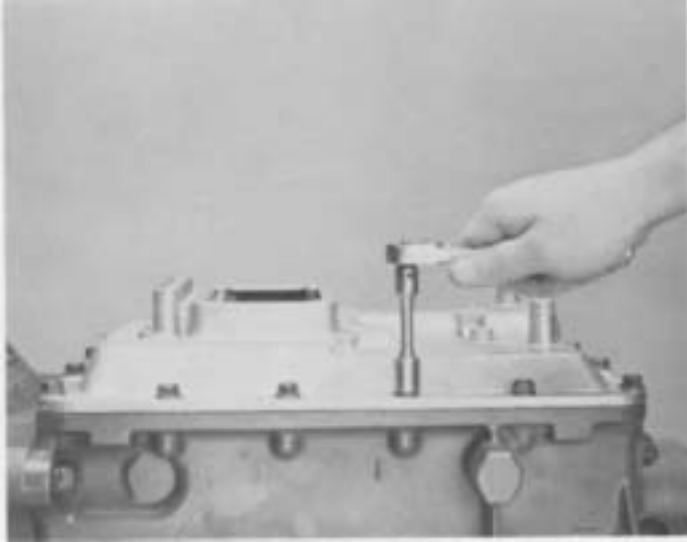

19-01

1. Shift transmission into neutral position, turn out cap screws, and lift shift bar housing and gasket from case.

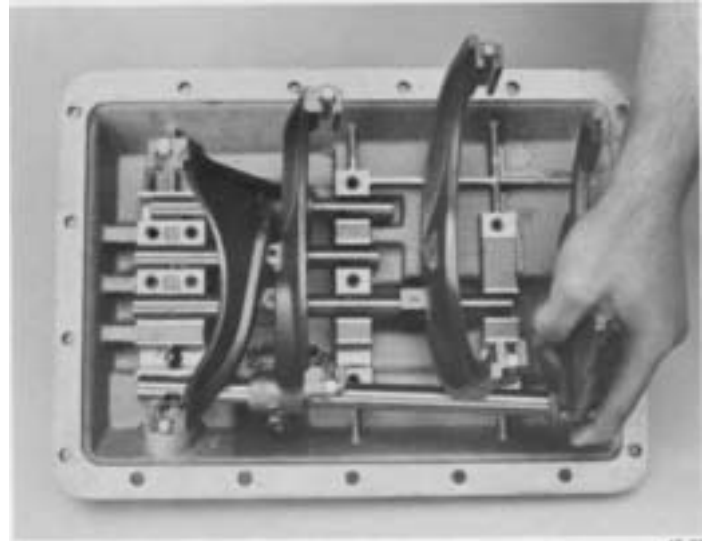

19-03

3. Remove reverse yoke assembly.

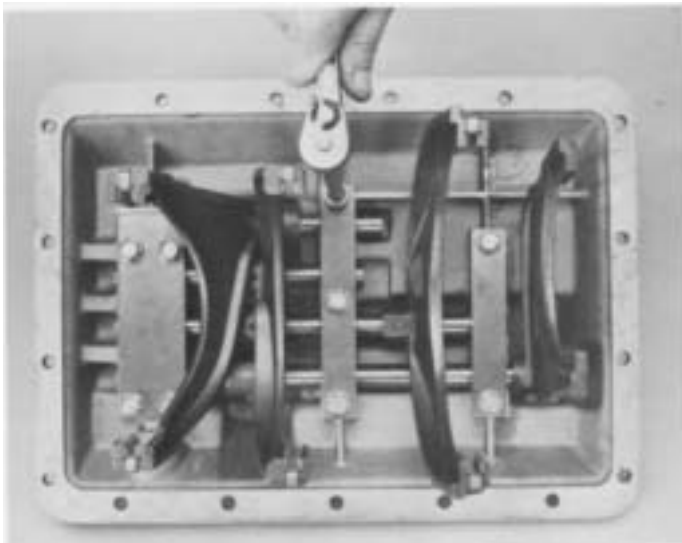

2. Lay shift bar housing on workbench as shown. Slide 5th-6th yoke into 5th position and remove cap screws and retainers.

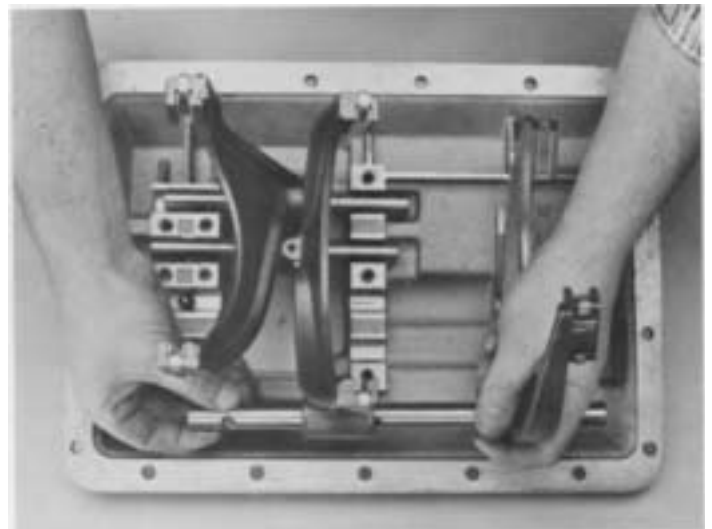

19-04

4. Remove 1st-2nd yoke assembly and interlock pin.

DISASSEMBLY AND REASSEMBLY SHIFTING CONTROLS

SHIFT BAR HOUSING ASSEMBLY (con't.)

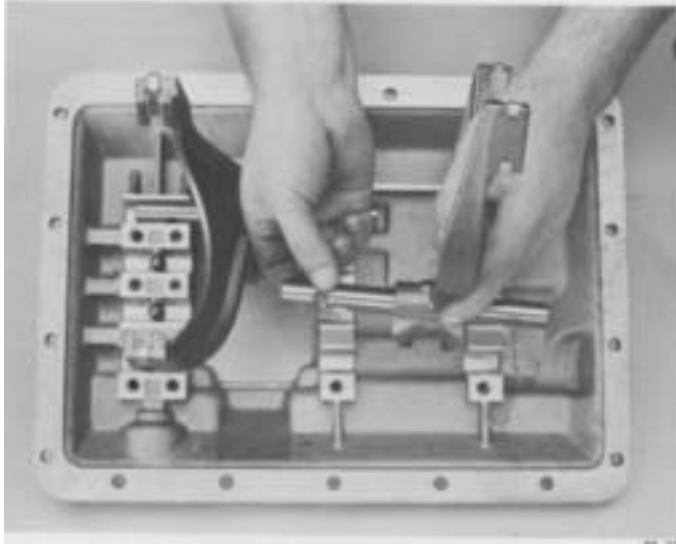

5. Remove 3rd-4th yoke assembly and interlock pin.

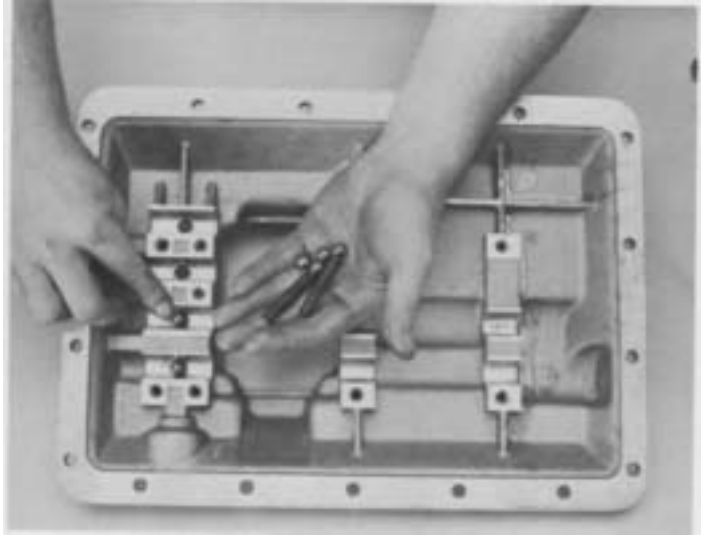

7. Remove interlock balls, detent balls, and springs.

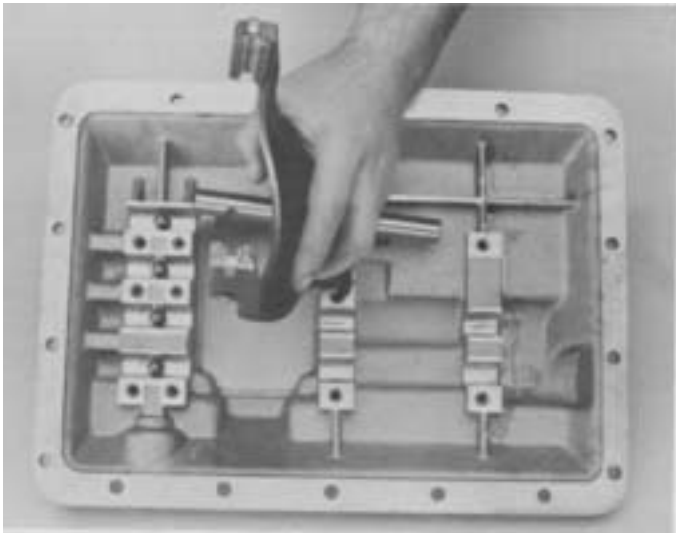

6. Remove 5th-6th yoke.

NOTE: If yoke replacement is required, yoke can be removed by driving the roll pin through the yoke and rail. If the yoke pad inserts are to be replaced, remove worn pad from shift fork, install new pad, and bend tabs over top and bottom of fork.

DISASSEMBLY AND REASSEMBLY SHIFTING CONTROLS

SHIFT BAR HOUSING ASSEMBLY (con't.)

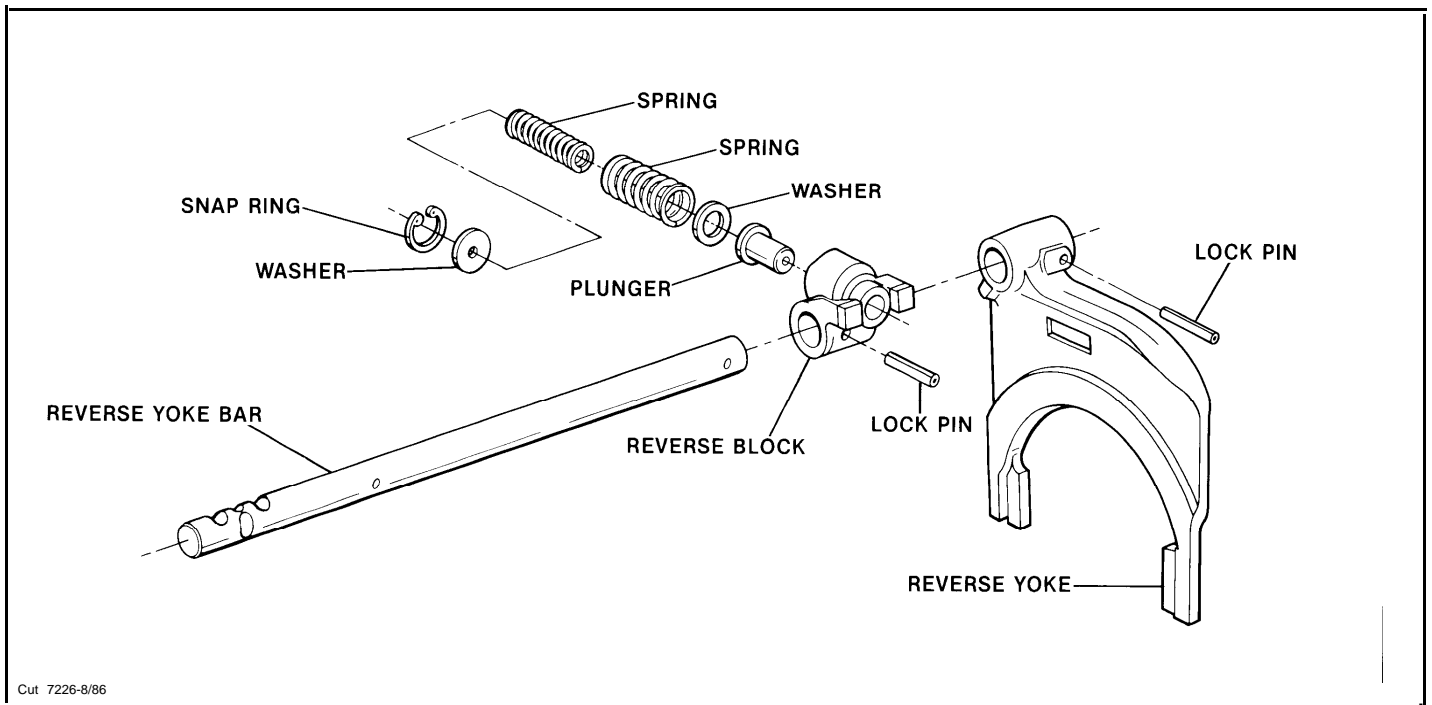

B. Disassembly of Reverse Plunger

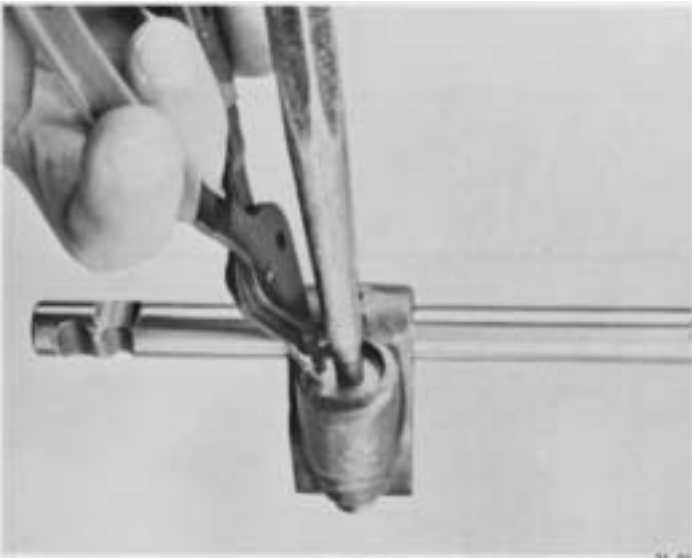

1. Depress reverse plunger springs and retainer as shown. Remove snap ring and spring retainer.

CAUTION

SNAP RING AND RETAINER ARE UNDER SPRING PRESSURE.

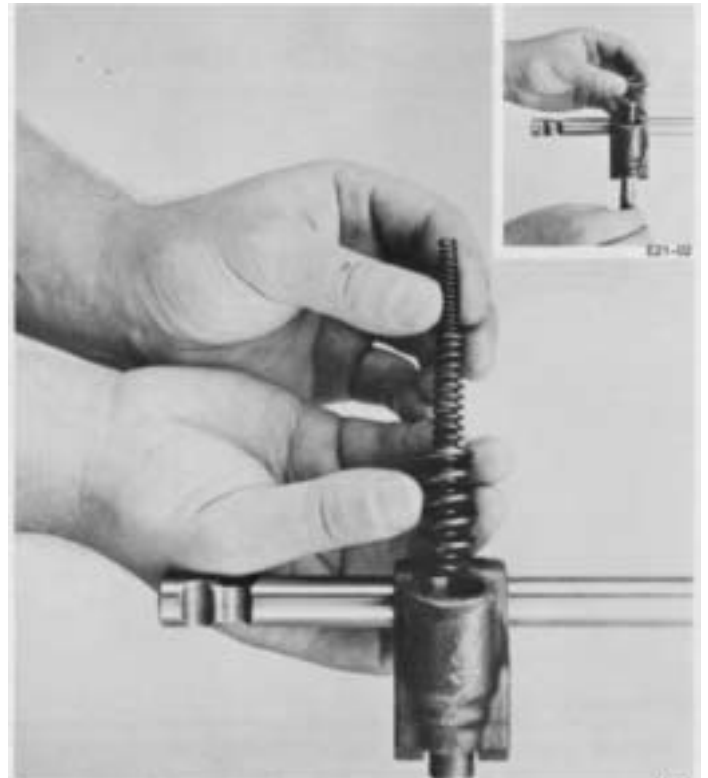

2. Remove reverse plunger springs.
NOTE: Some assemblies may only use two springs.
Remove washer and plunger (inset).

DISASSEMBLY AND REASSEMBLY SHIFTING CONTROLS

SHIFT BAR HOUSING ASSEMBLY (cont.)

C. Reassembly of Reverse Plunger Assembly

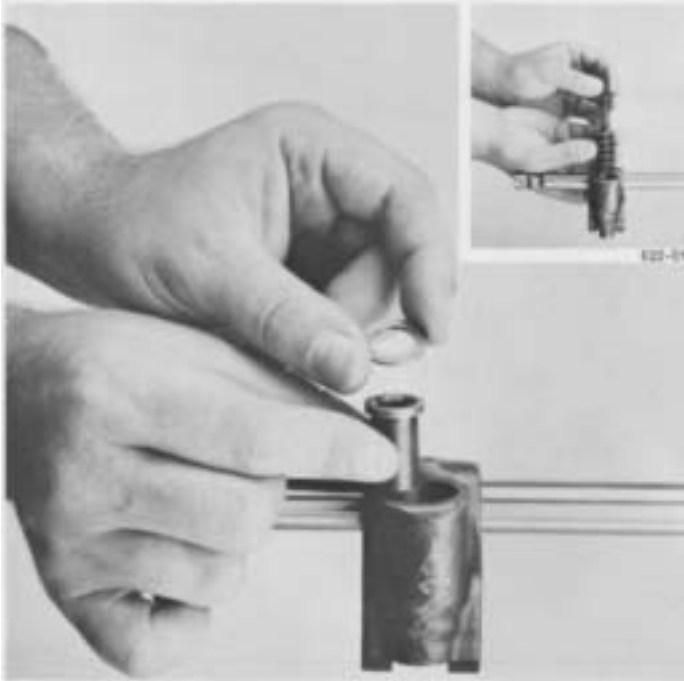

1. Install plunger and washer as shown and install reverse plunger springs (inset).

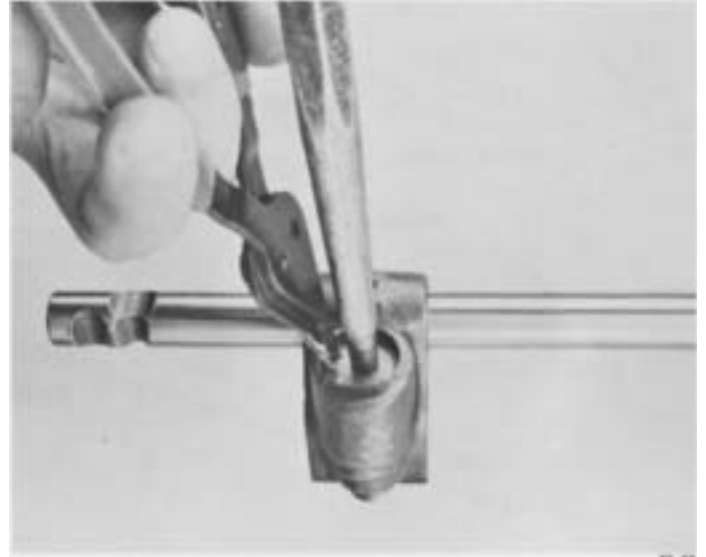

2. Depress reverse plunger retainer and springs and install snap ring in groove of shift block.

D. Reassembly of Shift Bar Housing

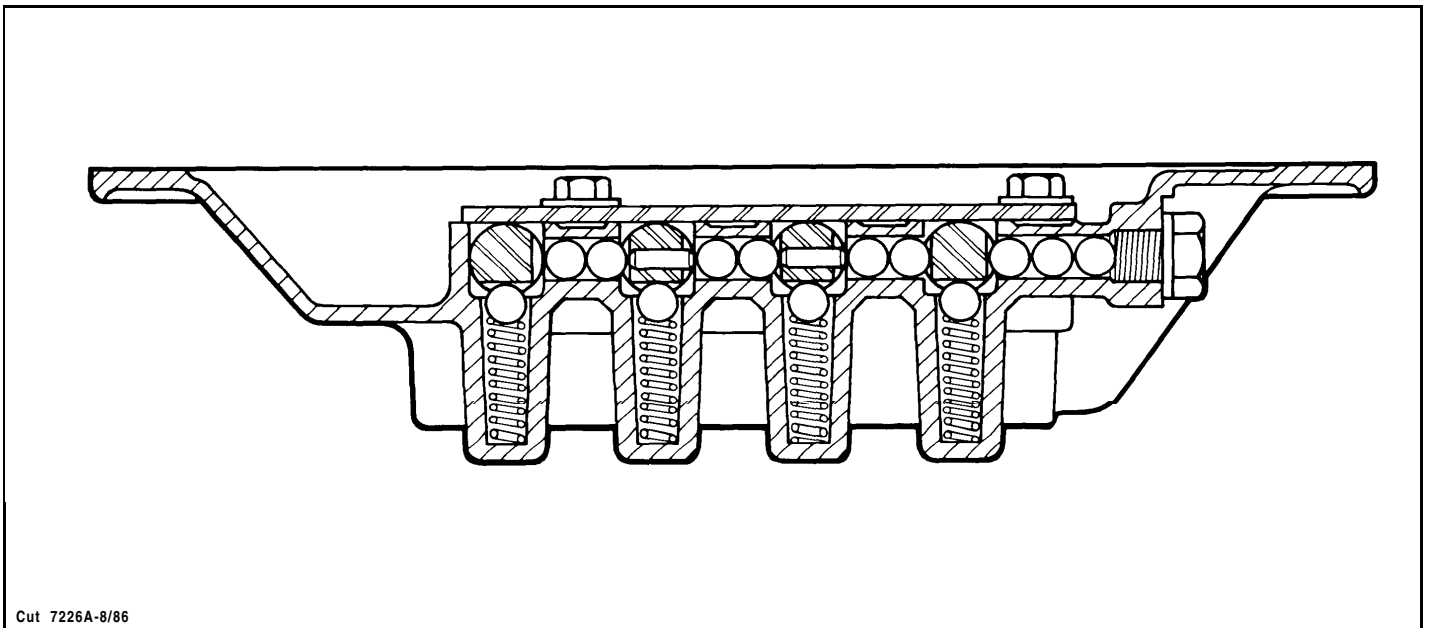

1. Install interlock balls, detent balls and springs in the following sequence; position (3) balls in the reverse light switch bore and install reverse detent spring and ball. Position (2) balls in adjacent cross bore and install 1st and 2nd detent spring and ball. Position (2) balls in adjacent cross bore and

install 3rd and 4th detent spring and ball. Position (2) balls in adjacent cross bore and install 5th and 6th detent spring and ball.

NOTE: Balls and springs can be used interchangeably.

DISASSEMBLY AND REASSEMBLY SHIFTING CONTROLS

SHIFT BAR HOUSING ASSEMBLY (cont.)

NOTE: All yoke assemblies must be installed in the neutral position.

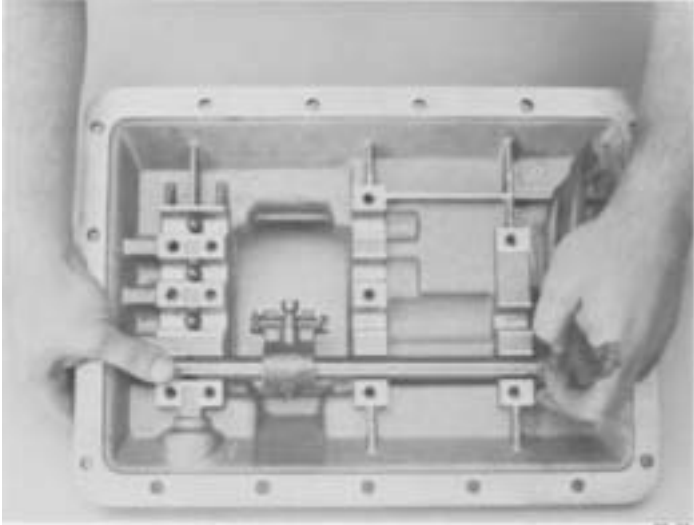

23-02

2. Position reverse yoke in housing assembly as shown.

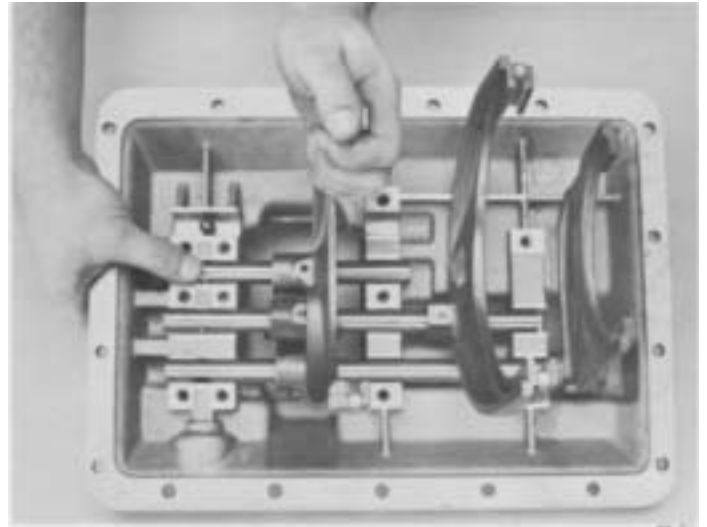

4. Install interlock pin in 3rd-4th yoke assembly and position as shown.

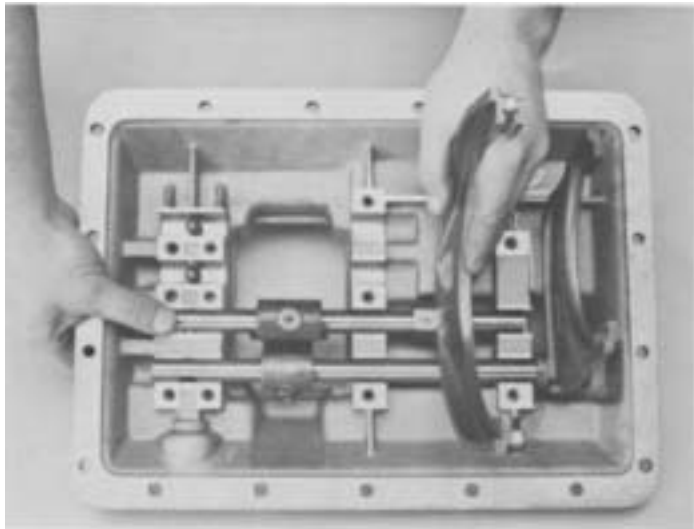

23-03

3. Install interlock pin in 1st-2nd yoke assembly and position as shown.

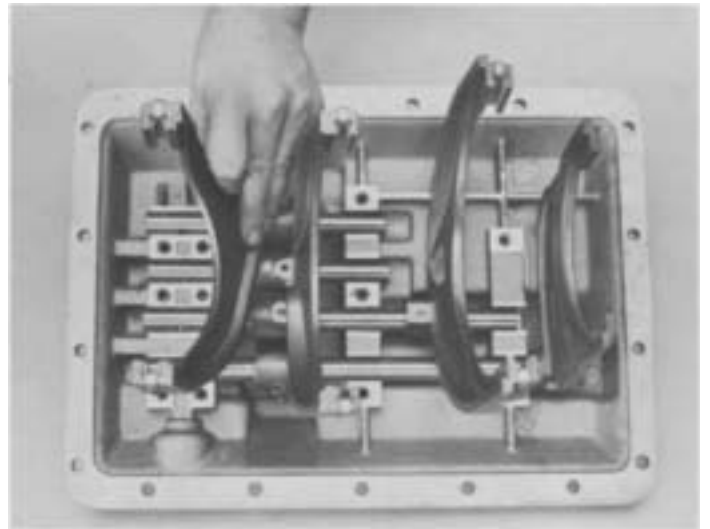

23-05

5. Position 5th-6th yoke assembly in housing as shown.

DISASSEMBLY AND REASSEMBLY SHIFTING CONTROLS

SHIFT BAR HOUSING ASSEMBLY (con't.)

NOTE: The shift yoke retainer capscrew holes are not tapped on new shift bar housing. The capscrews that are used are "thread forming" and can be reused if the shift bar housing is replaced.

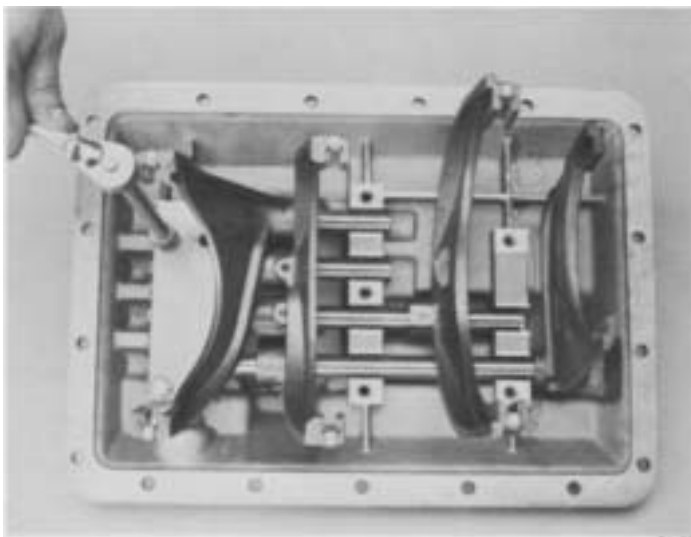

6. Position shift yokes as shown. Install front retainer over shift rails and install front (2) capscrews.

NOTE: It may be necessary to support rails in proper position while installing rail supports.

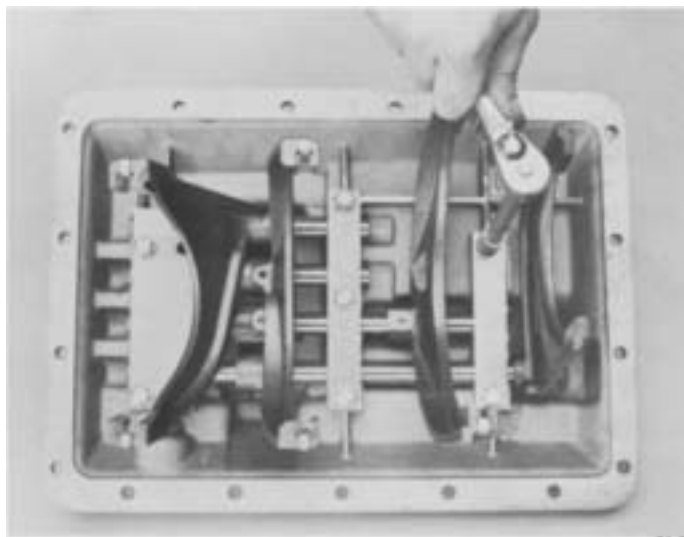

8. Position rear retainer over shift rails and install capscrews.

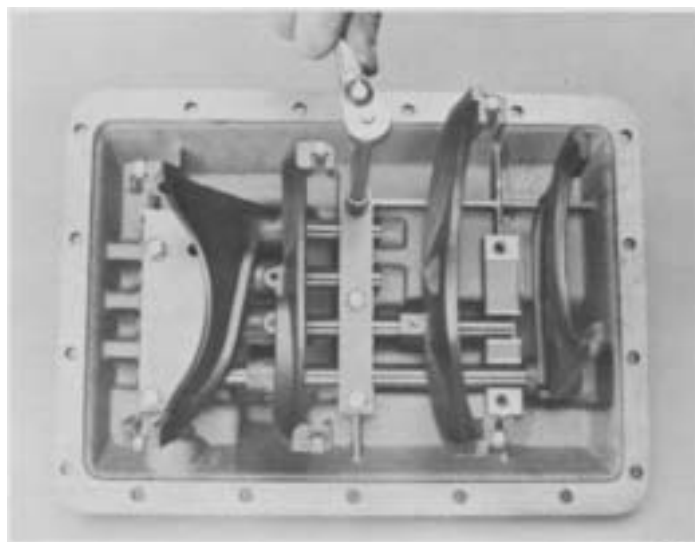

7. Position shift yokes as shown and install center retainer and capscrews.

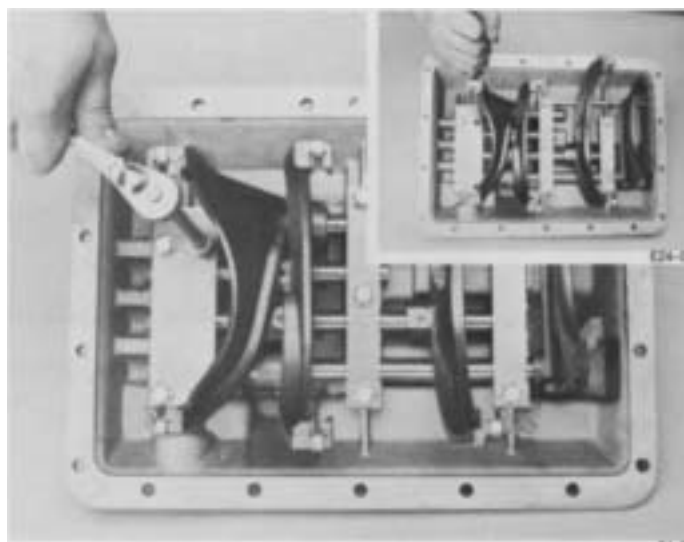

9. Slide 5th-6th shift yoke into 5th position (inset) and install remaining 2 capscrews. Return 5th-6th yoke to neutral position. Tighten all retainer capscrews to 20-25 lbs.-ft. (27-34 N.m).

REMOVAL - YOKE AND CLUTCH HOUSING

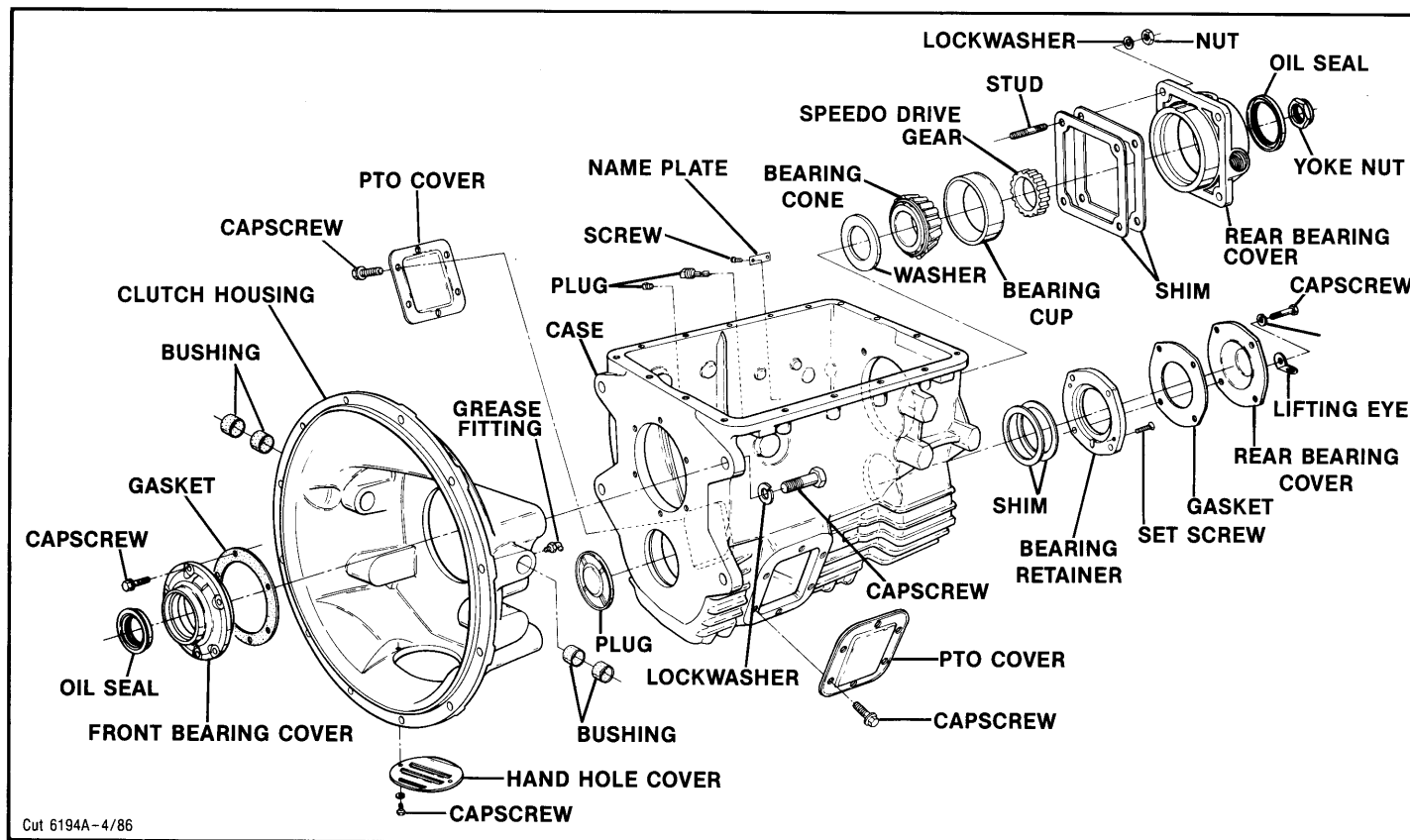

A. Removal of Yoke

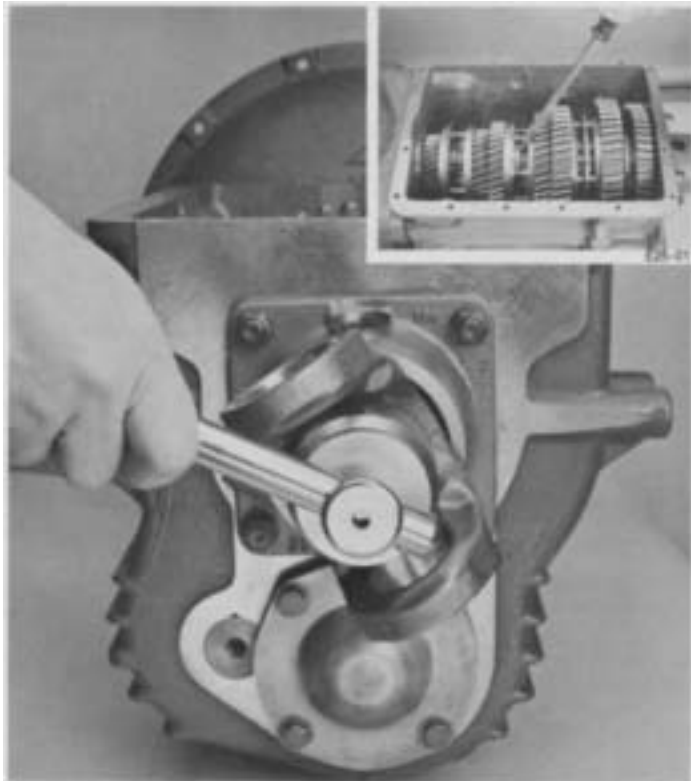

1. Lock the transmission by engaging two mainshaft gears (inset). use a large breaker bar to turn the nut from the output shaft.



2. Remove yoke from output shaft.

REMOVAL - YOKE AND CLUTCH HOUSING

B. Removal of Clutch Housing

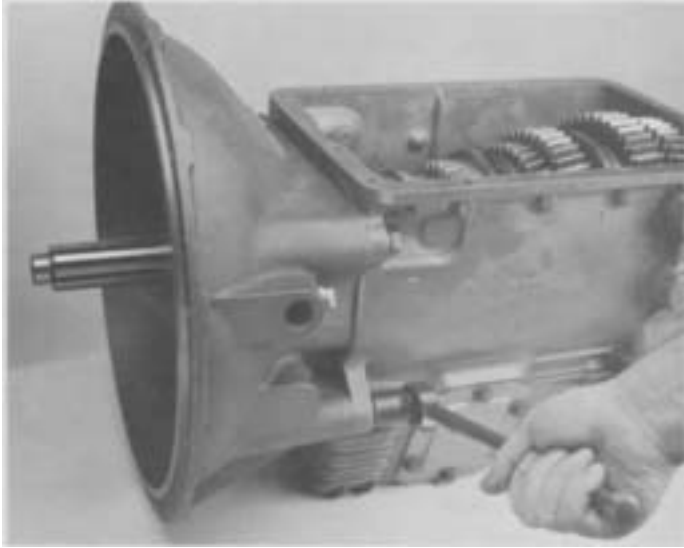

1. Remove four retaining bolts as shown.

26-01

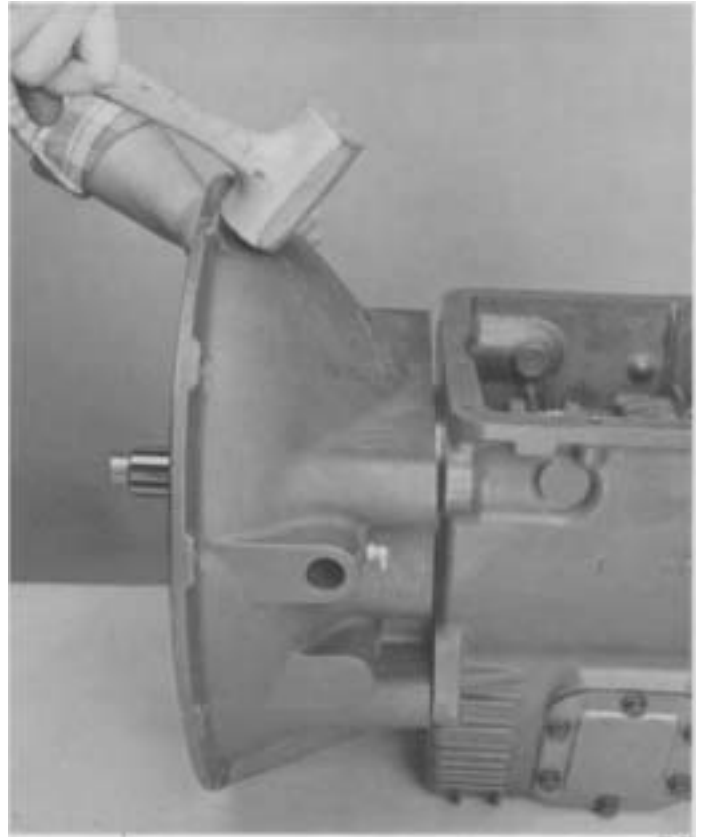

2. Jar clutch housing with rubber mallet and pull from transmission case.

26-02

DISASSEMBLY - TRANSMISSION

A. Removal & Disassembly of Input Shaft Assembly

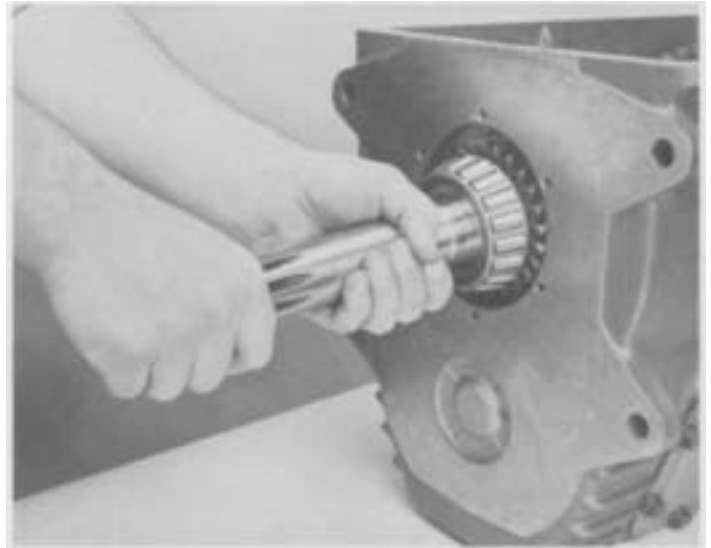
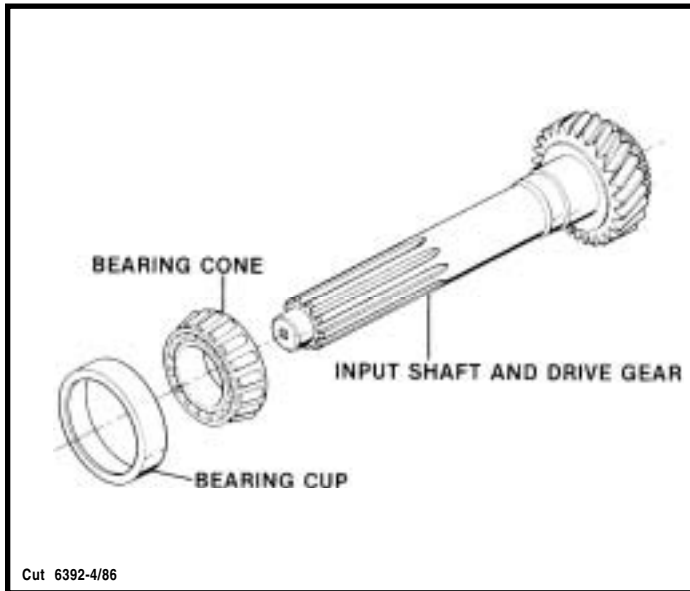

2. Remove input shaft assembly from transmission.

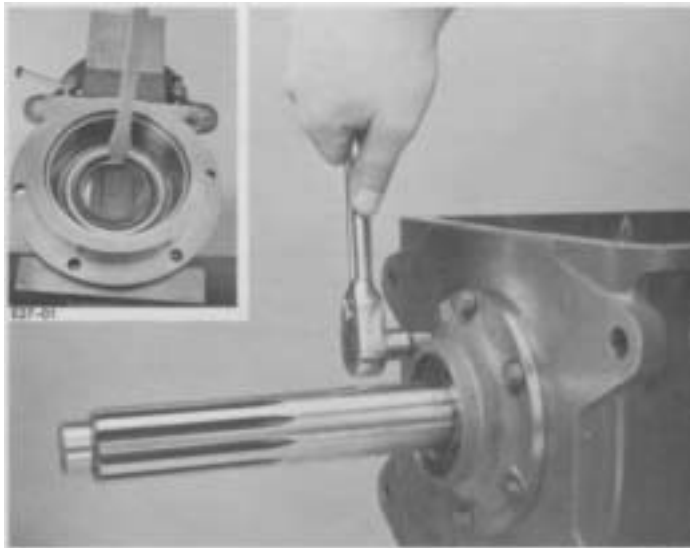

1. Turn out six capscrews, jar front bearing cover with a rubber mallet and remove. If necessary remove oil seal from cover (inset).



3. Using a chisel, remove bearing cage and rollers. install bearing puller and remove bearing race from input shaft.

DISASSEMBLY - TRANSMISSION

B. Removal & Disassembly of Mainshaft

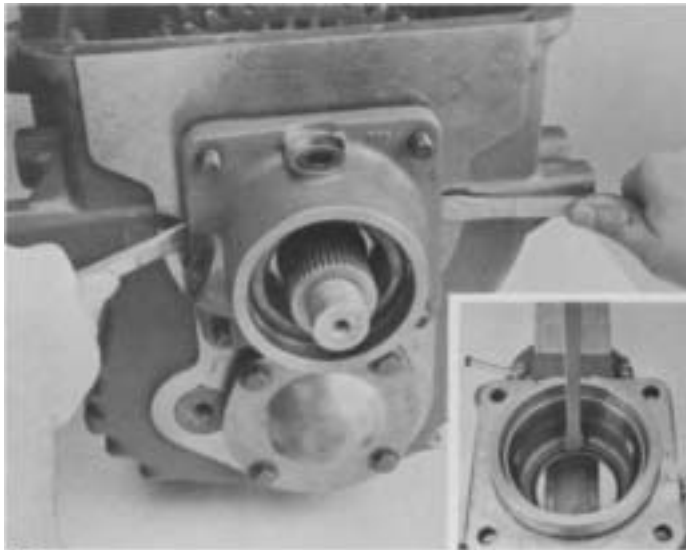
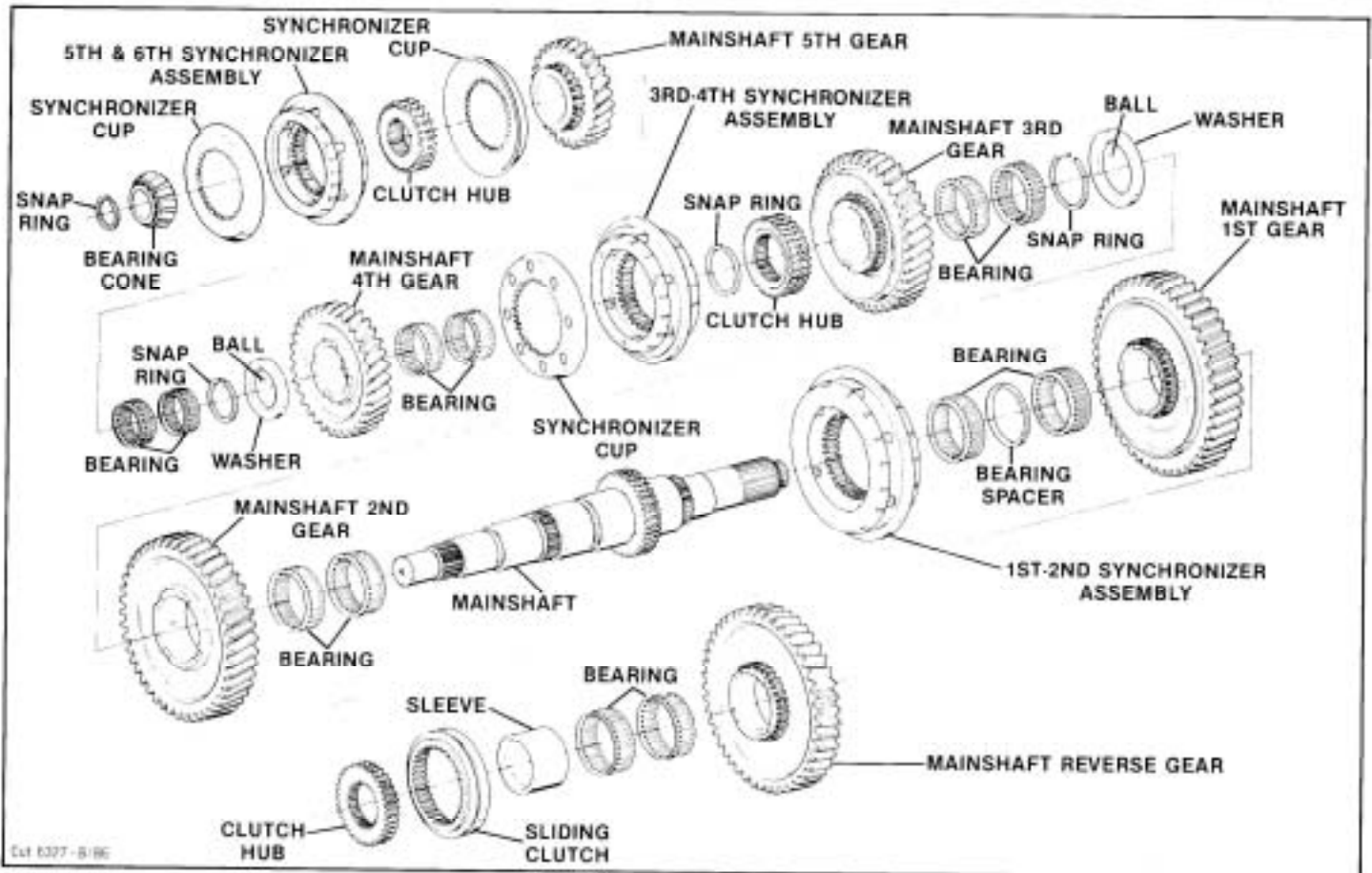

28-01

1. Turn out four retaining nuts and lockwashers. Using screwdrivers in notches, remove rear bearing cover. If necessary remove oil seal from cover (inset)

2. Remove shims and speedometer drive gear or rotor.

NOTE: Shims may come off with rear bearing cover.

DISASSEMBLY - TRANSMISSION

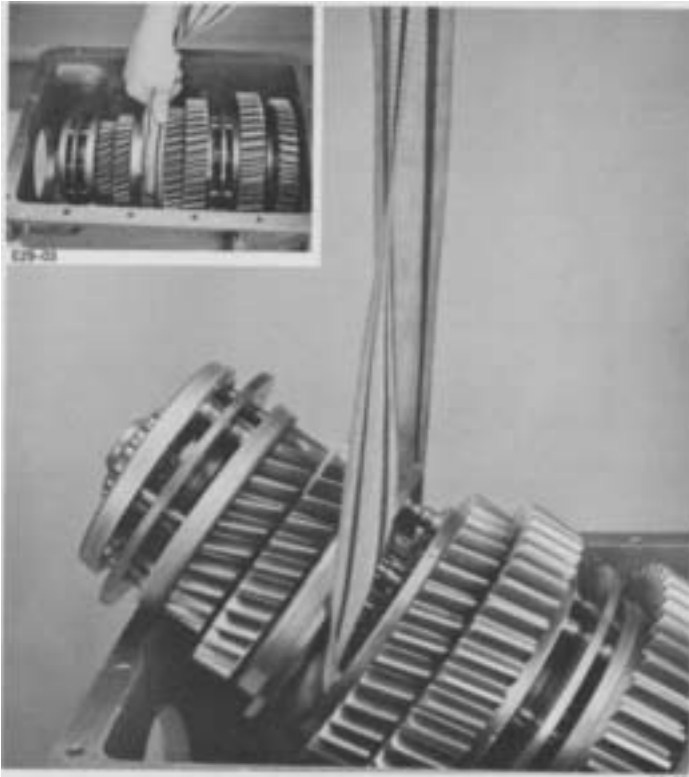

3. Wrap sling around the 3rd-4th synchronizer (inset). Use hoist to remove mainshaft assembly from case.

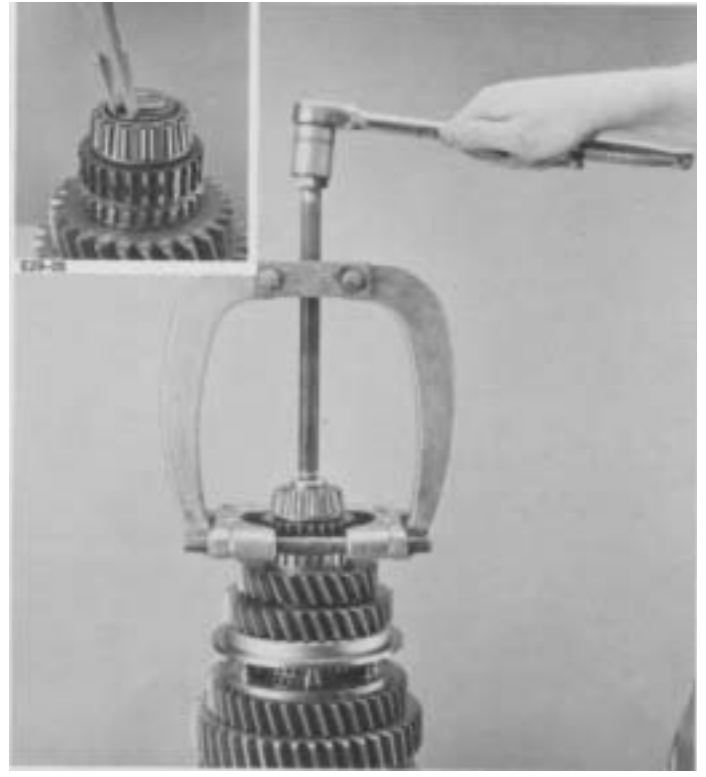

5. Remove snap ring from front of mainshaft front bearing (inset). Using a puller mounted behind 5th-6th shift hub, remove hub and bearing. 29-05



4. Install mainshaft assembly in vise equipped with soft jaws or wood, front of shaft facing up. Remove 5th-6th speed synchronizer and cups.



6. Remove 5th gear and bearings from mainshaft. 29-06

DISASSEMBLY - TRANSMISSION



7. Remove snap ring (inset), thrust washer, and locating ball.



9. Remove 4th speed synchronizer cup and 3rd-4th speed synchronizer



8. Remove 4th gear and bearings.

DISASSEMBLY - TRANSMISSION

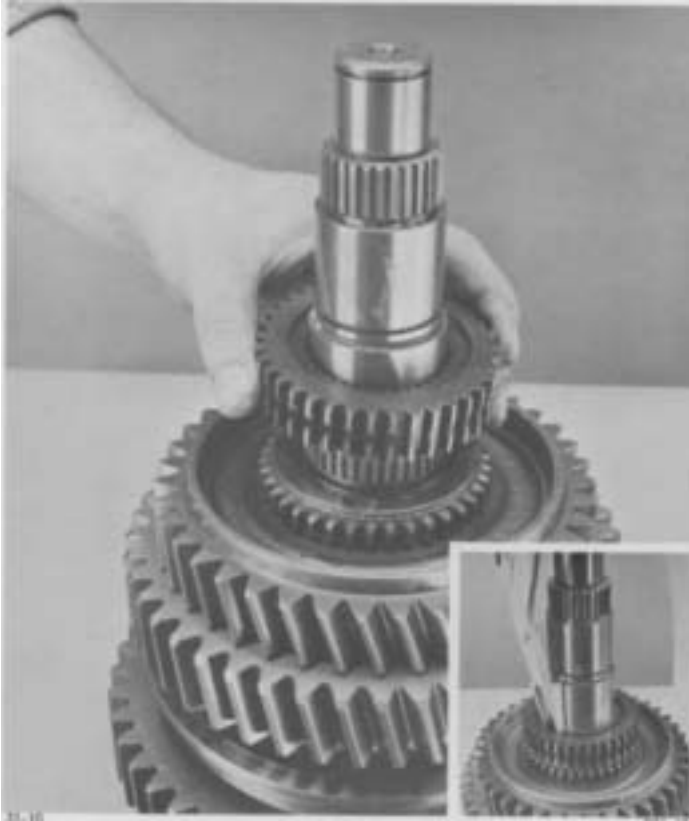

10. Remove snap ring (inset) and 3rd-4th shift hub.



12. Remove snap ring (inset), thrust washer and locating ball.



11. Remove 3rd gear and bearings from mainshaft.



13. Remove 2nd gear and bearings from mainshaft.

DISASSEMBLY - TRANSMISSION



14. Remove 1st-2nd speed synchronizer.

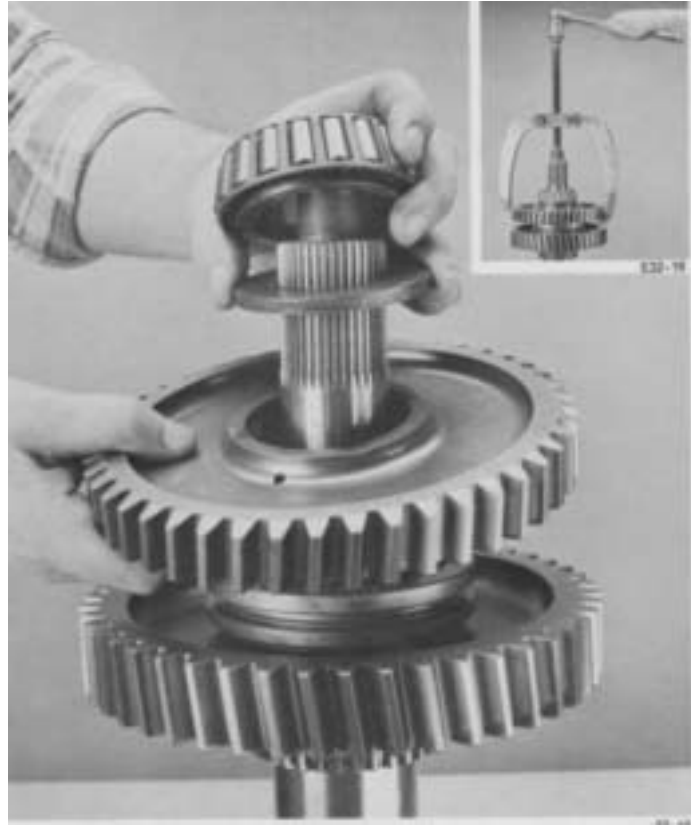

16. Using a puller (inset), remove reverse gear, spacer, and rear bearing.



15. Reposition mainshaft in vise, rear of shaft facing up.



17. Remove reverse gear bearings and reverse gear sliding clutch.

DISASSEMBLY - TRANSMISSION



18. Using a puller (inset) or press remove 1st gear, clutch hub, and reverse gear bearing race from mainshaft.



19. Remove first gear bearing and spacer.

DISASSEMBLY - TRANSMISSION

C. Removal and Disassembly of Countershaft and Reverse Idler

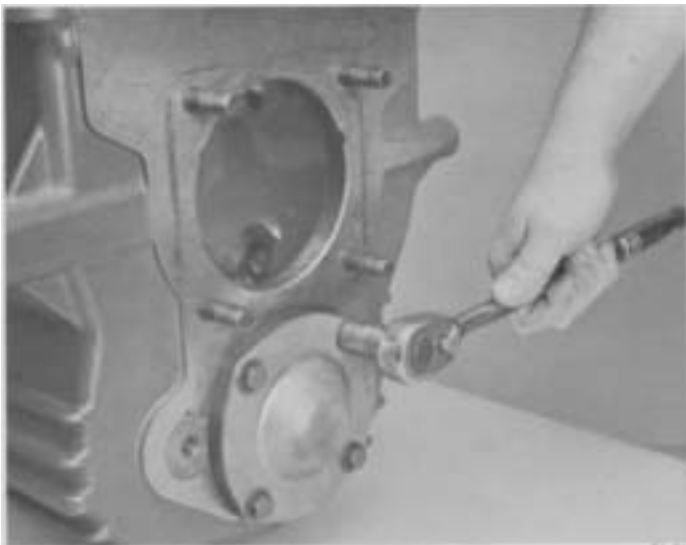
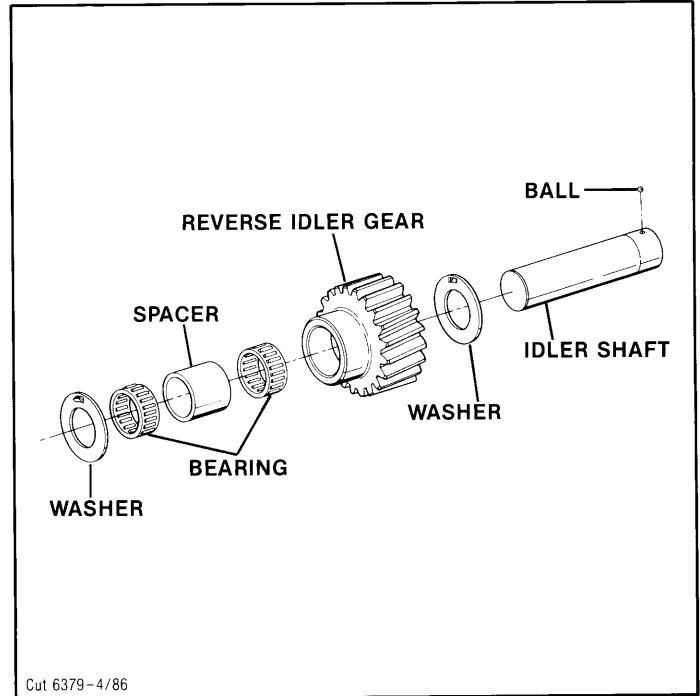
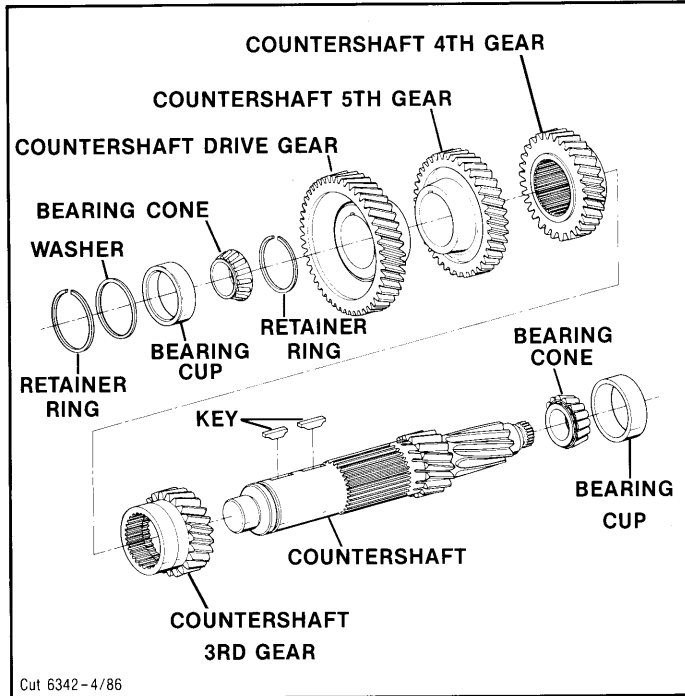

1. Turn out four cap screws, remove countershaft rear bearing cover and gasket.

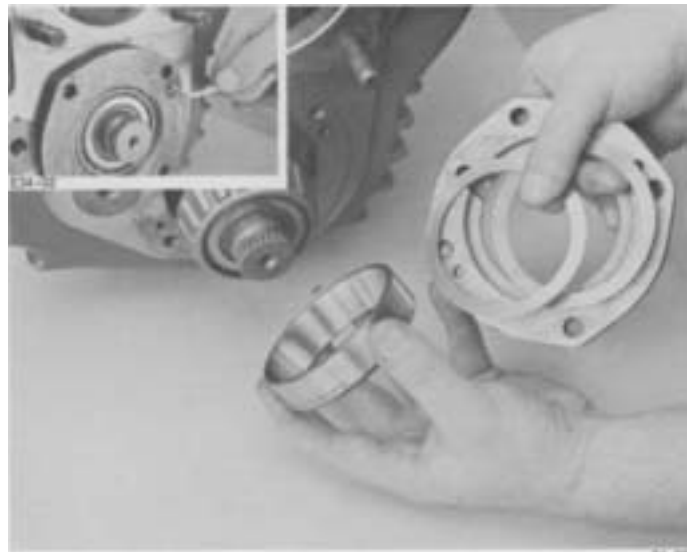

2. Turn out two set screws (inset). Remove bearing retainer, outer race, and shims (inset).

NOTE: Countershaft may slide to the rear and out of bearing bore.

DISASSEMBLY - TRANSMISSION

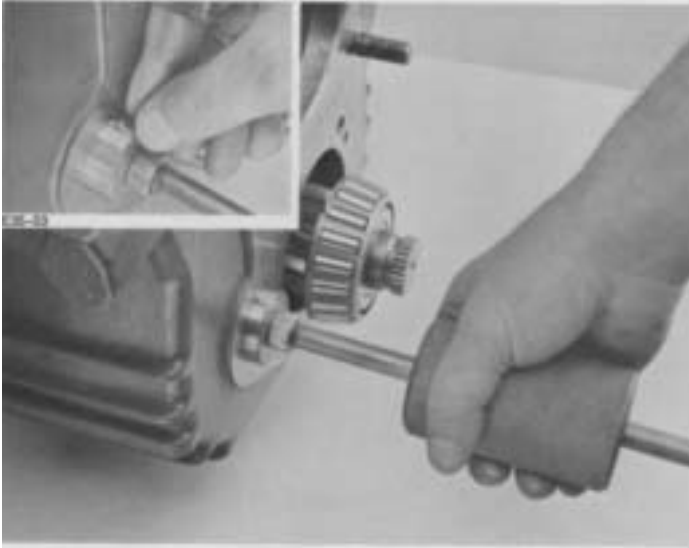

3. Using a slide hammer remove reverse idler shaft. Remove locating ball once it is exposed (inset).

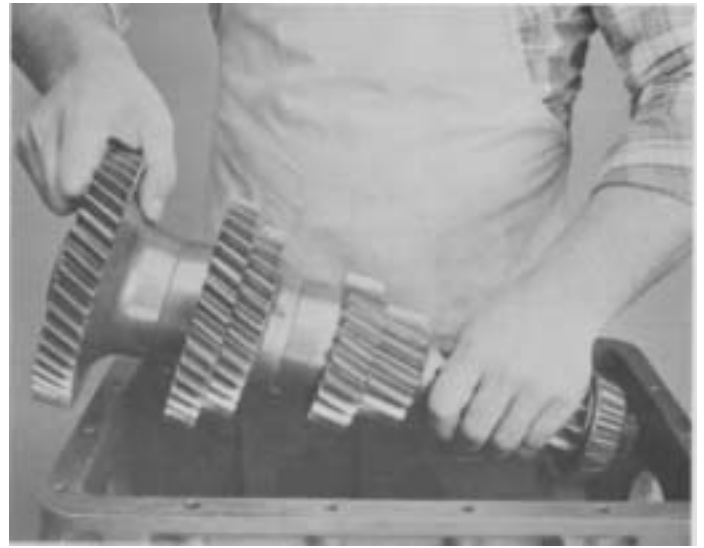

5. Move countershaft assembly to the rear and lift it from the case.

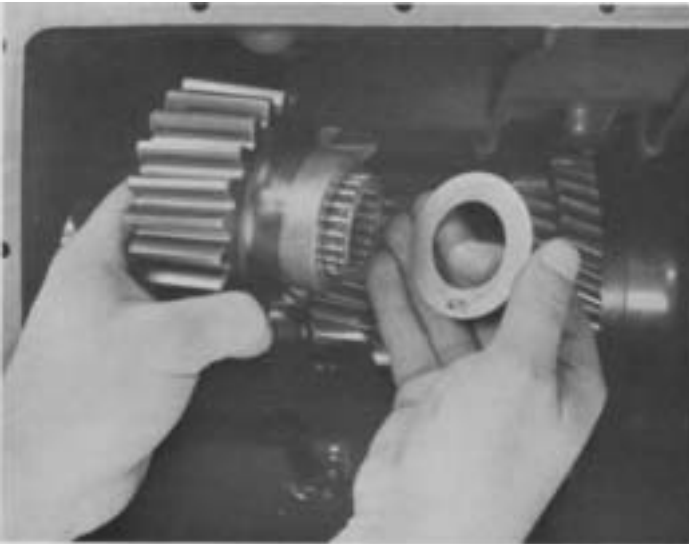

4. Remove reverse idler, bearings, spacer and thrust washers,

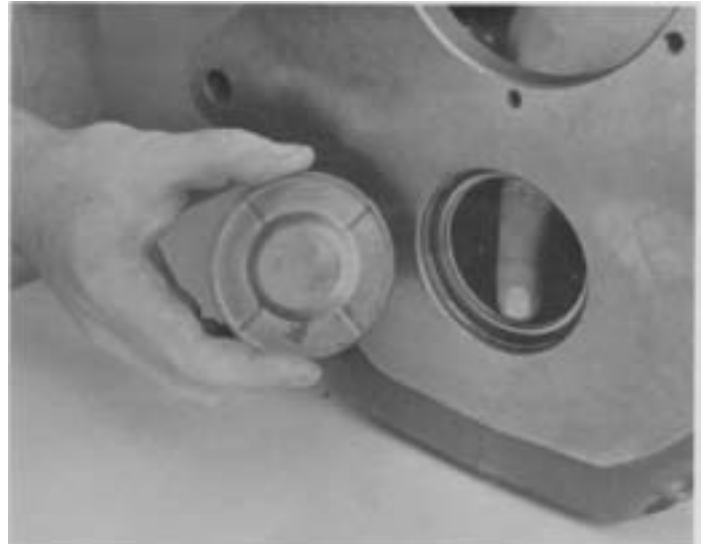

6. If countershaft front bearing race is to be replaced, drive bore plug through front of transmission and drive the race to the rear toward the inside of the case.

DISASSEMBLY - TRANSMISSION



7. Position puller jaws behind rear countershaft bearing and remove bearing.

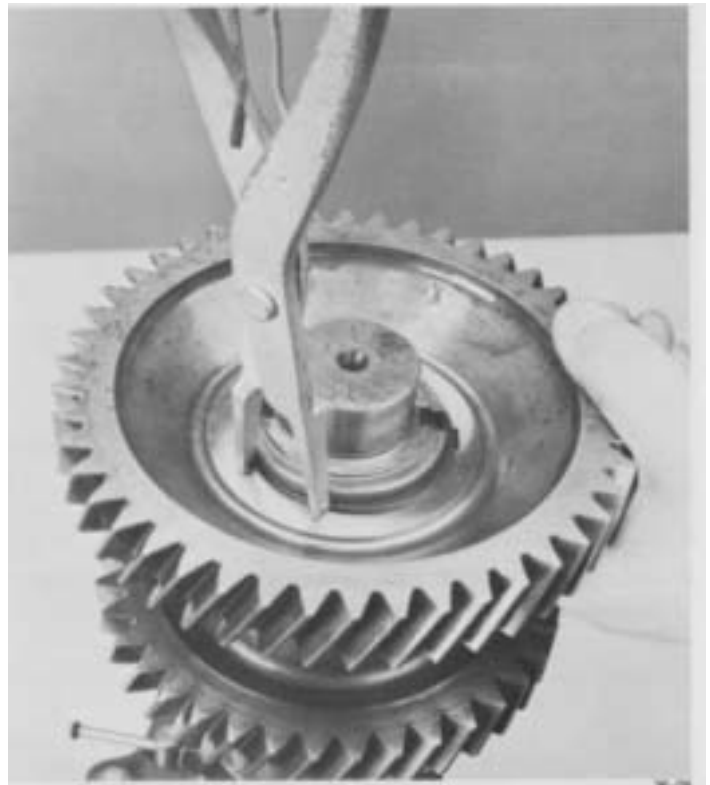

9. Remove drive gear retaining snap ring from front of shaft.



8. Position countershaft in vise, front of shaft facing up. Position puller jaws into notches behind front countershaft bearing and remove bearing.

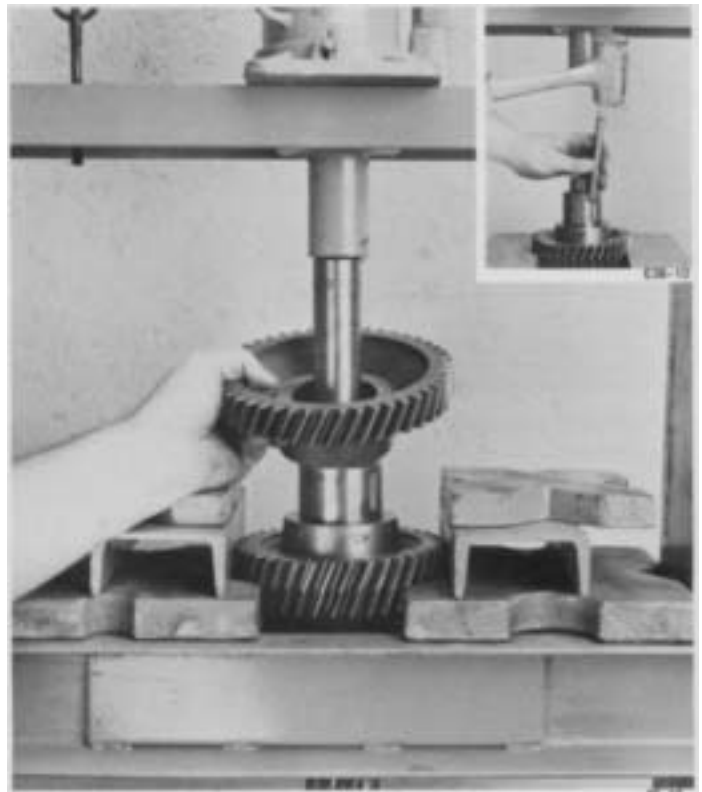

10. Use the rear face of the drive gear as a base, then press it from the countershaft as shown. Remove drive gear locating key from shaft (inset).

DISASSEMBLY - TRANSMISSION

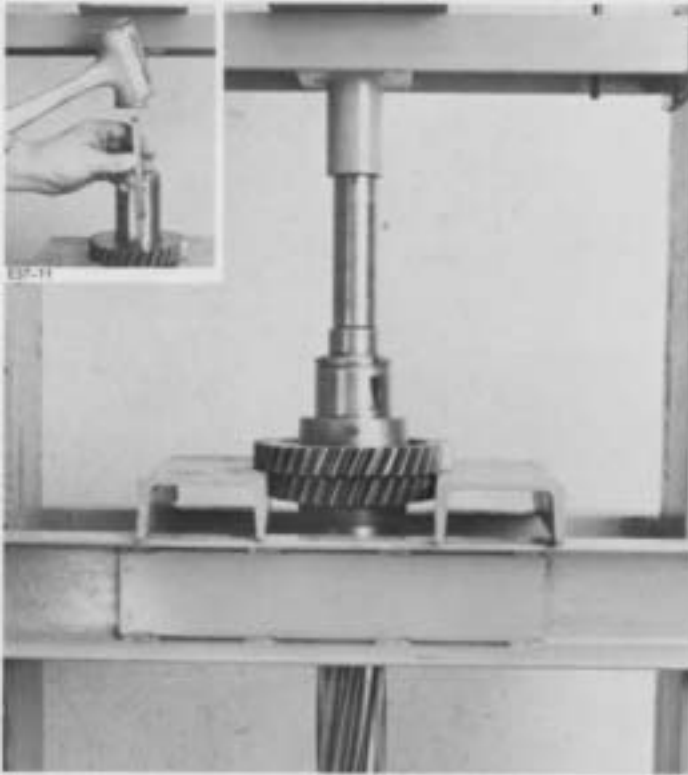

11. Using the rear face of 5th speed gear as a base, press it from the countershaft. Remove 5th gear key from shaft (inset).

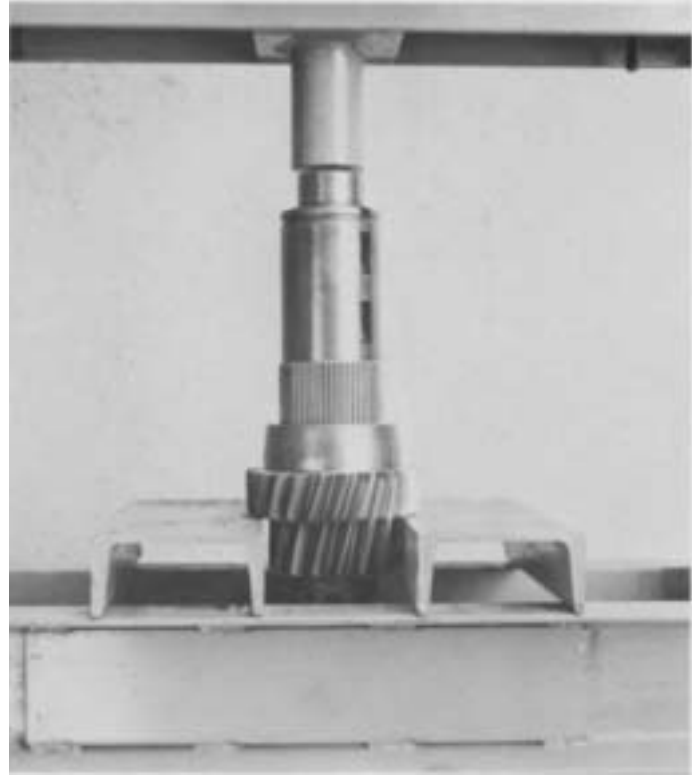

13. Using the rear face of 3rd speed gear as a base, press it from the countershaft. 37-13

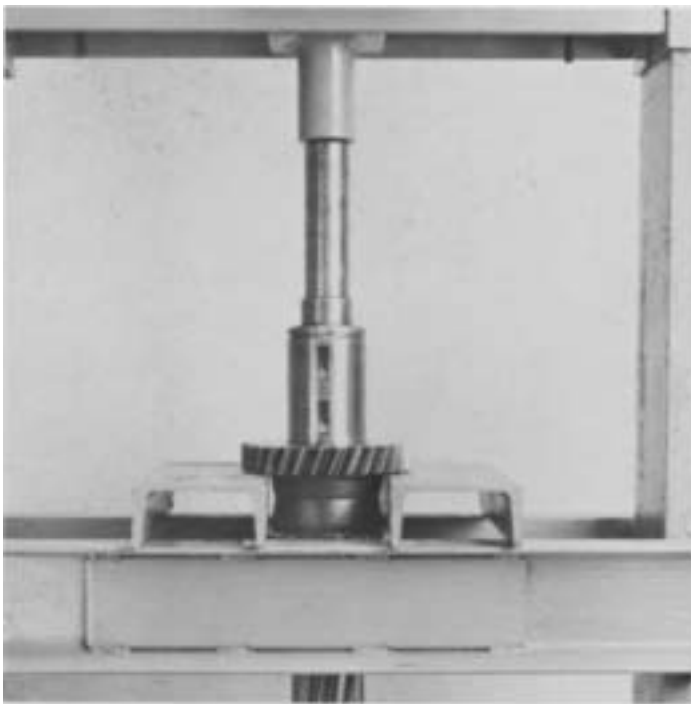

12. Using the rear face of 4th speed gear as a base, press it from the countershaft. 37-12
- NOTE:** Be sure that 5th and 6th speed gear keys have been removed before removing 4th gear from countershaft.

REASSEMBLY - TRANSMISSION

A. Reassembly and Installation of Countershaft and Reverse Idler

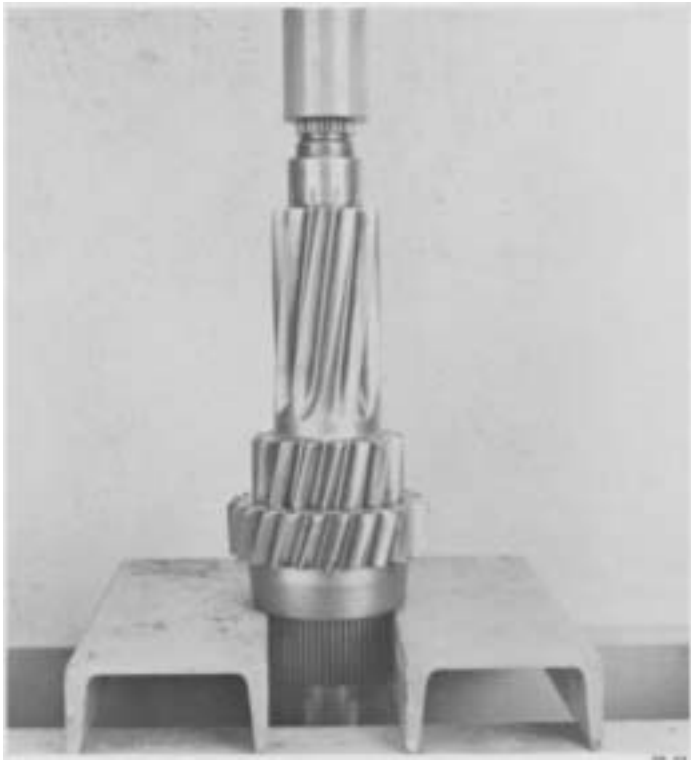

1. Press 3rd gear on countershaft as shown, splined end of gear hub to front of shaft.

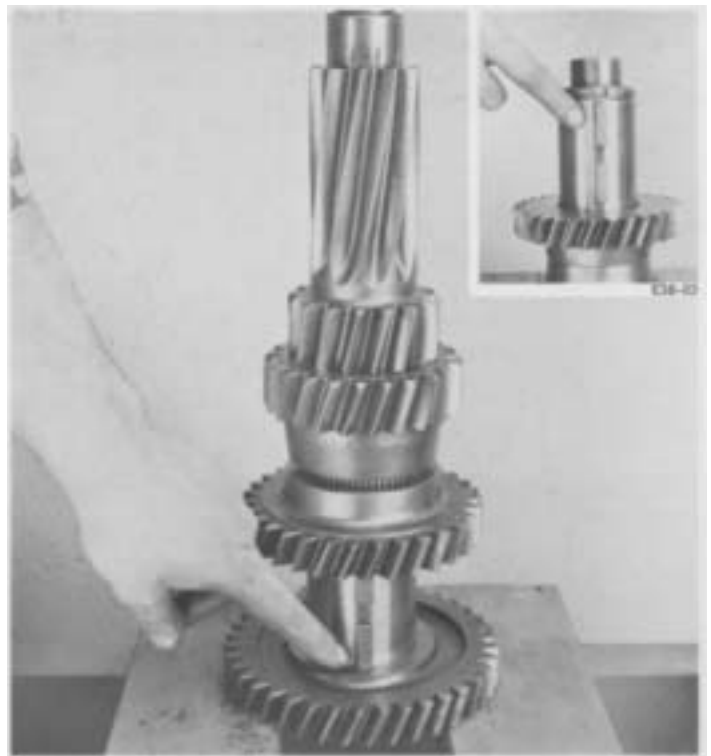

3. Install 5th and 6th speed gear keys on countershaft (inset). Align keyway of 5th speed gear to key on shaft. Press 5th gear on, long hub of gear to front of shaft.

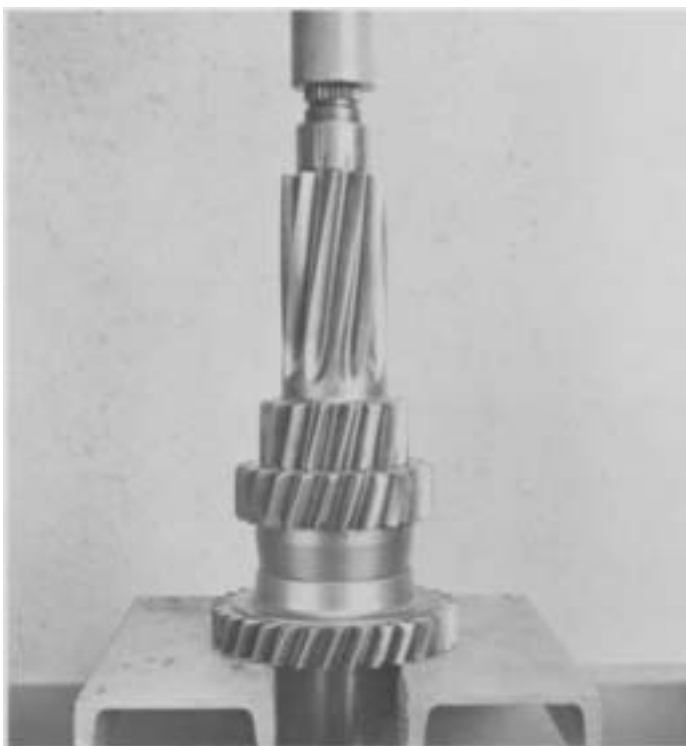

2. Press 4th speed gear on countershaft, long hub of gear to rear of shaft.



4. Align keyway of drive gear to key on countershaft. Press drive gear on, long hub of gear to rear of shaft.

REASSEMBLY - TRANSMISSION



5. Install snap ring in groove at front of countershaft.



7. Install rear countershaft bearing as shown.



6. Install front countershaft bearing as shown.



8. If previously removed, install snap ring, countershaft front bearing race (from inside of case) and bore plug. Coat outer diameter of bore plug with Loctite #510 before installing.

REASSEMBLY - TRANSMISSION



9. Carefully lower countershaft into case.



11. Use grease on reverse idler thrust washers to hold in place. Position tangs of washers in groove of housing.

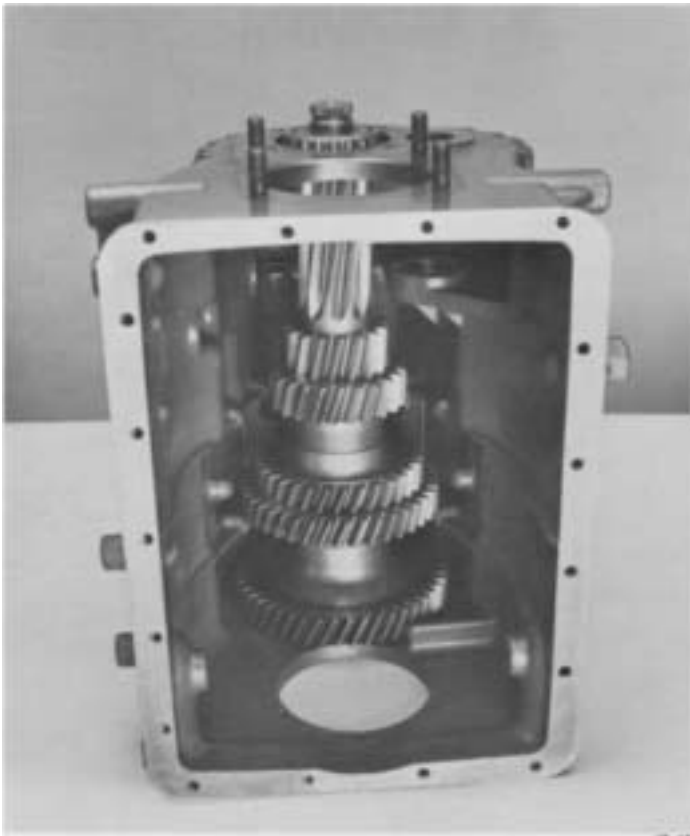

10. Turn transmission case on end as shown. Position countershaft assembly into front bearing race.

REASSEMBLY - TRANSMISSION

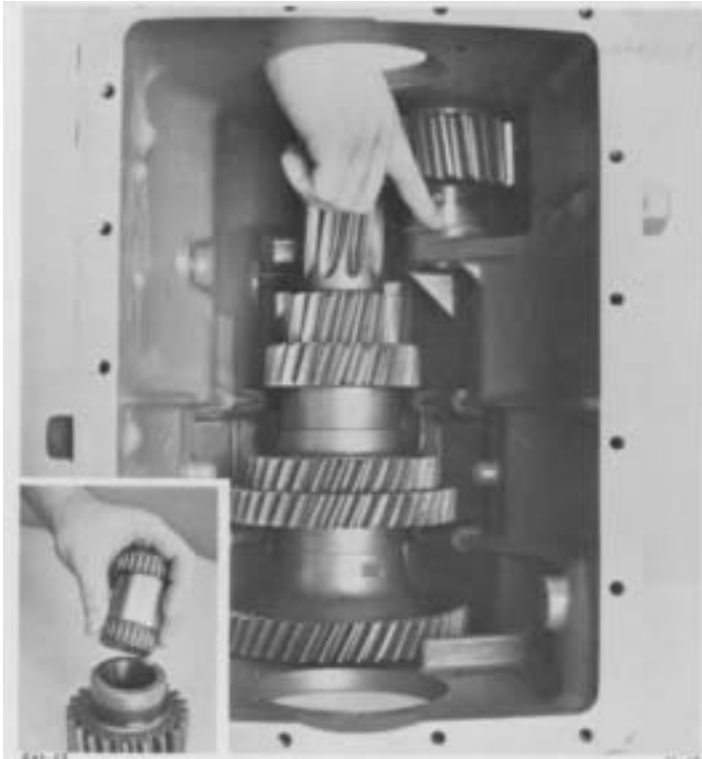

12. Install bearings and spacer in reverse idler gear (inset) and position gear in housing with long hub of gear toward the front.



14. Install countershaft rear bearing race into case as shown.



13. Insert idler shaft through case and idler gear bearings. Line up notch in shaft with notch in case, install lock ball, and drive shaft into position (inset).

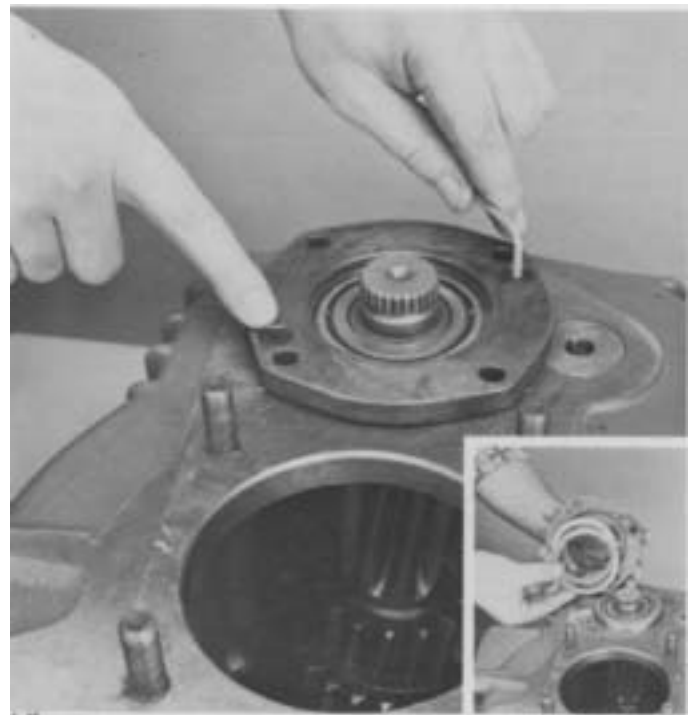

14. Temporarily install new shims into bearing retainer (inset). Install retainer. Tighten set screws to 5-10 lbs. ft. (7-14 Nm)

NOTE: Lube hole in retainer must line up with lub hole in case.

REASSEMBLY - TRANSMISSION

B. Reassembly and Installation of Mainshaft



1. Install mainshaft in vise equipped with wood or brass jaws, rear of mainshaft facing up. Lubricate and install first gear bearings with spacer between bearings as shown.

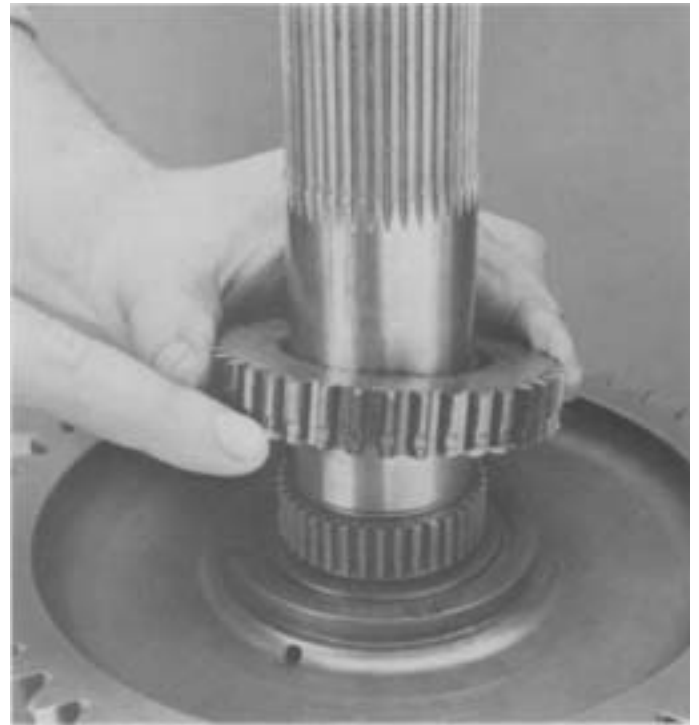

3. Install reverse gear clutch hub with notched teeth facing down.

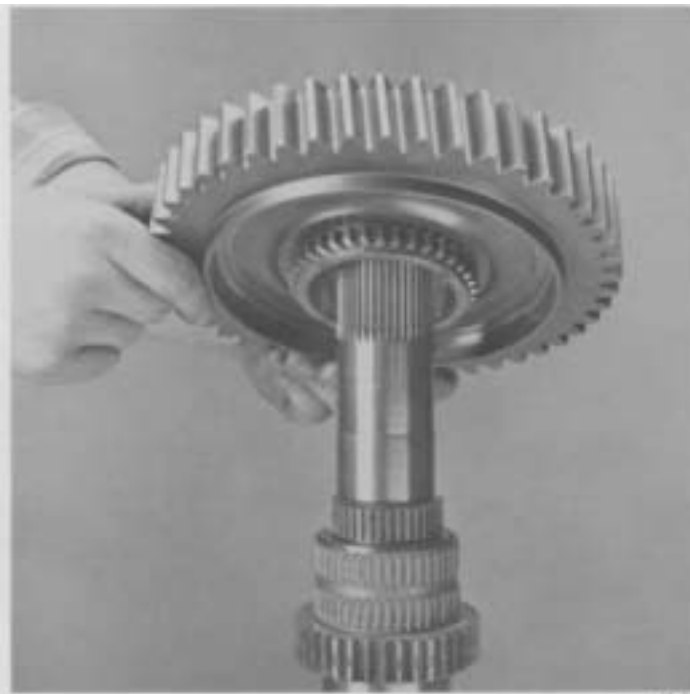

2. Install mainshaft 1st gear, clutching teeth of gear facing down.

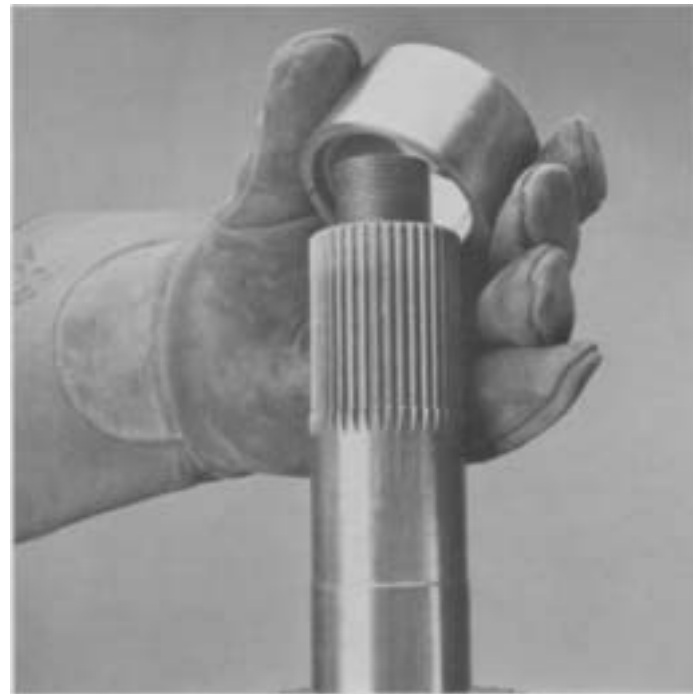

4. Using heat lamp or hot plate and oil, heat reverse gear bearing race and install on shaft with notched end facing down. Race can also be installed using a sleeve type driver.

NOTE: Do not heat reverse bearing race over 320°F (160°C).

REASSEMBLY - TRANSMISSION



5. Install reverse gear sliding clutch with stepped shoulder down.

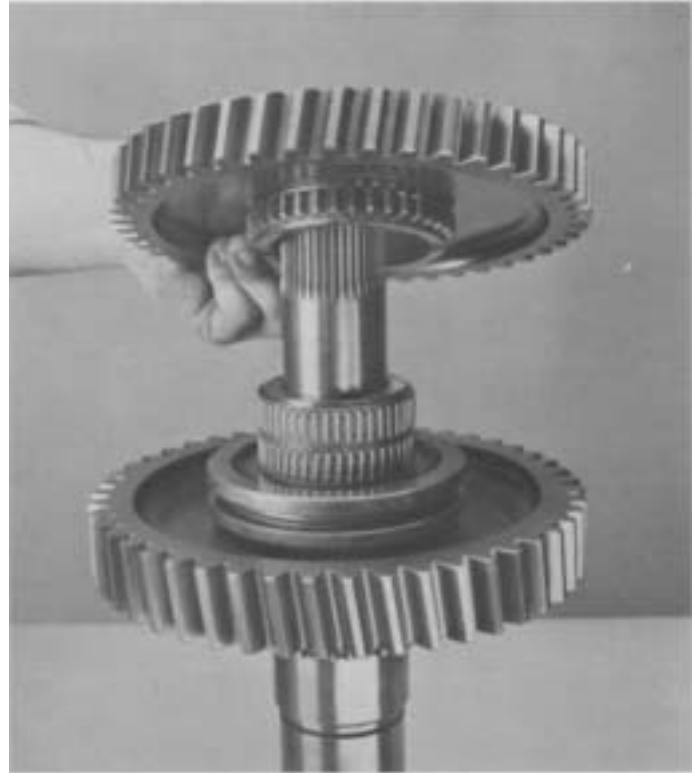

7. Install reverse gear with clutching teeth facing down.

44-07

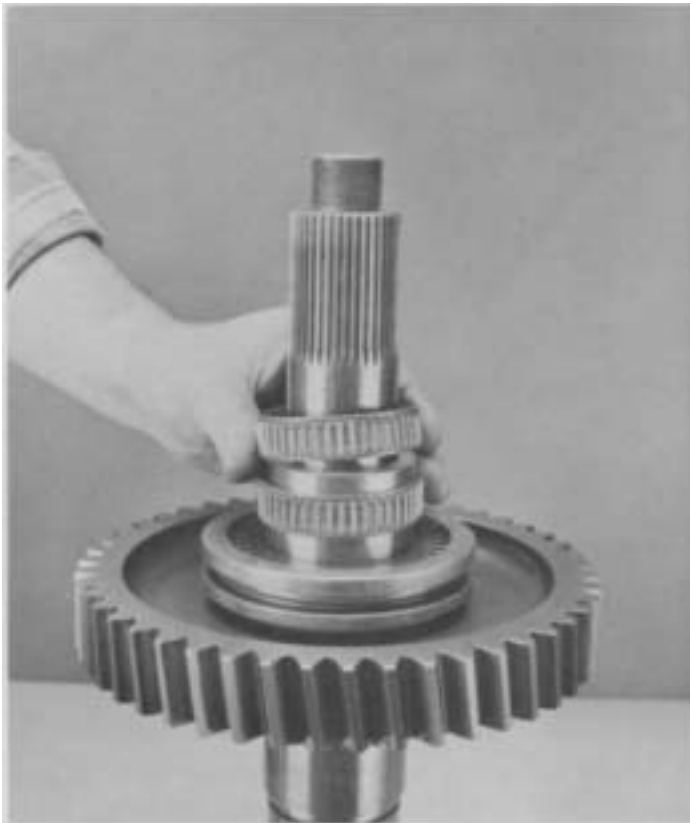

6. Lubricate and install reverse gear bearings on race.

44-06



8. Install reverse gear washer. Washer can be installed either way.

44-08

REASSEMBLY - TRANSMISSION



45-09

9. Using a sleeve type driver install rear mainshaft bearing as shown.



11. Lubricate and install 2nd gear bearings (inset). Install 2nd gear, clutching teeth facing down.



45-10

10. Reposition mainshaft in vise with front of mainshaft facing up. Lubricate friction surface with transmission lube and install 1st-2nd speed synchronizer.

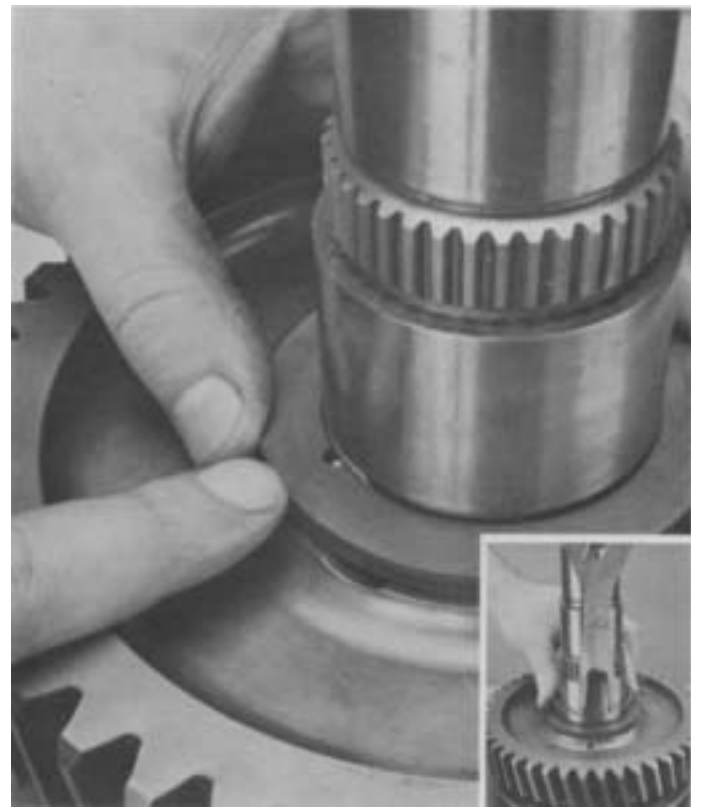

45-12

E45-12

12. Install locating ball and washer. Washer can be installed either way. Install snap ring as shown (inset).

REASSEMBLY - TRANSMISSION

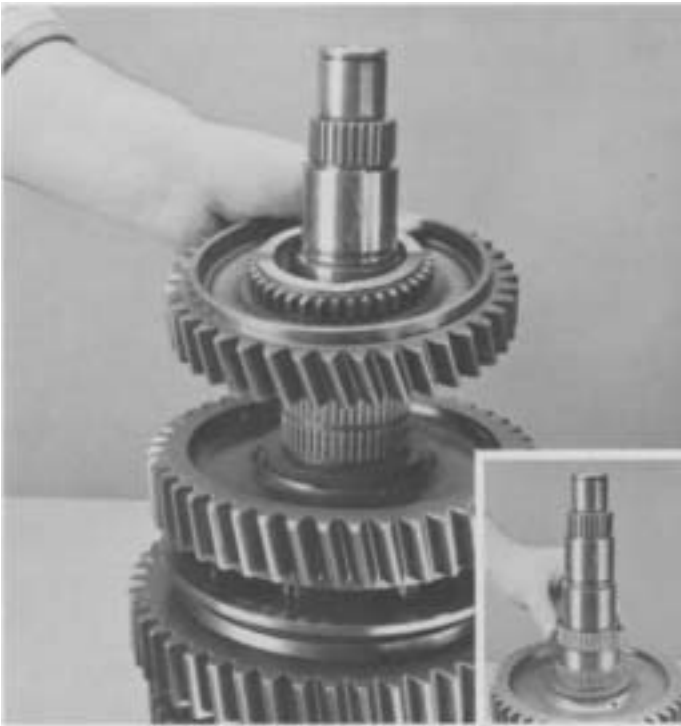

46-13

13. Lubricate and install 3rd gear bearings (inset). install 3rd gear, clutching teeth facing up.

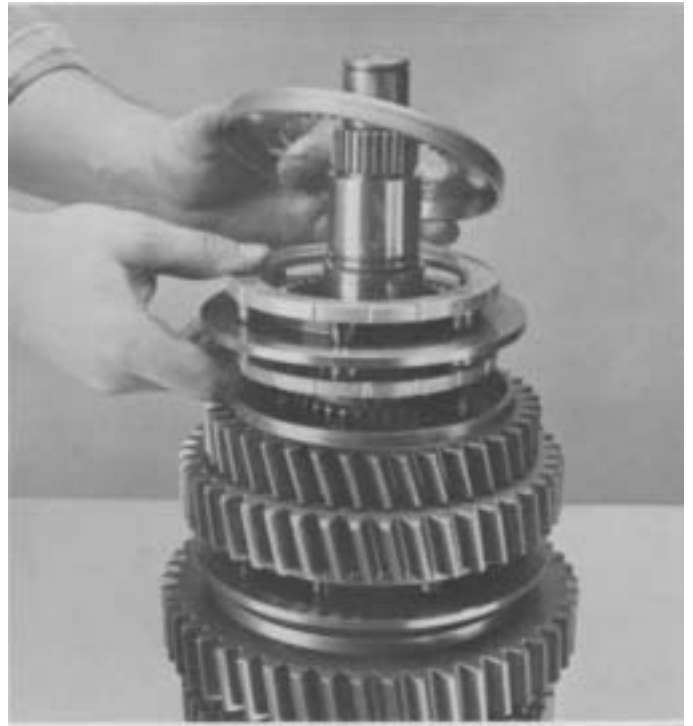

46-15

15. Lubricate friction surface with transmission lube and install 3rd-4th speed synchronizer and 4th speed synchronizer cup.

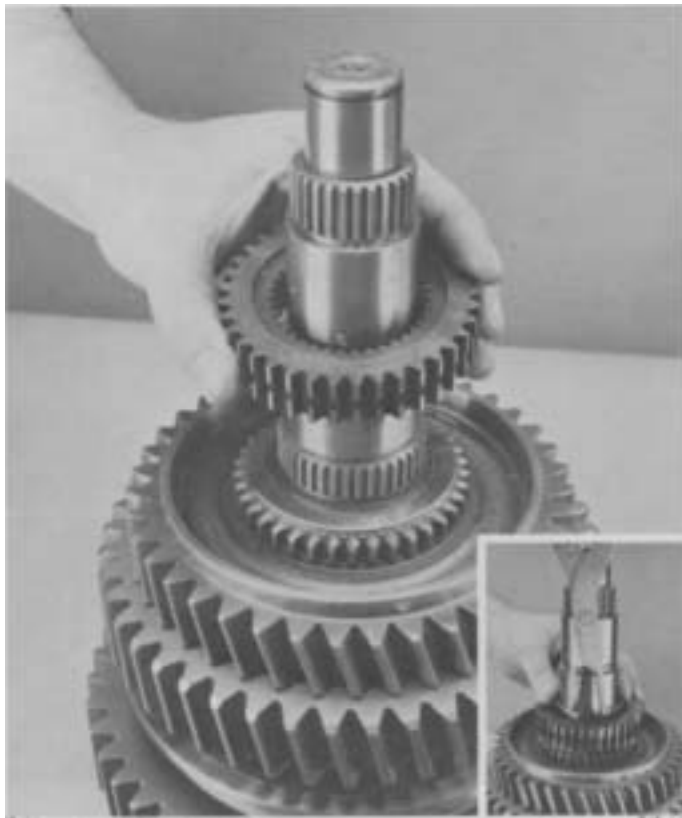

14. Install 3rd-4th clutch hub with stepped face of hub facing up. Install snap ring in groove of mainshaft (inset).



16. Lubricate and install 4th gear bearings (inset). Install 4th gear, clutching teeth facing down.

REASSEMBLY - TRANSMISSION



17. Install locating ball and washer. Washer can be installed either way. Install snap ring as shown (inset).



19. Install 5th-6th clutch hub with flat surface facing up.



18. Lubricate and install 5th gear bearings (inset). install 5th gear, clutching teeth facing up.

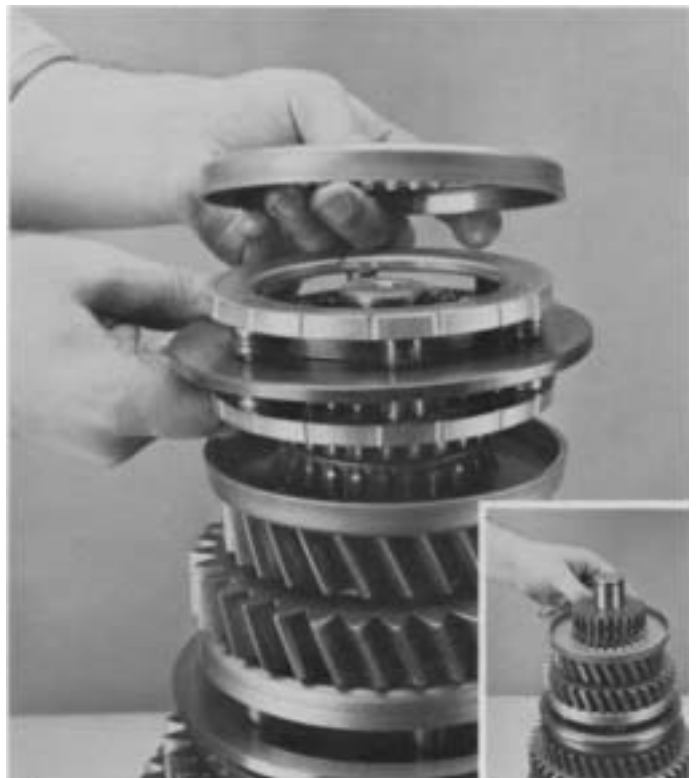

20. Install 5th speed synchronizer cup (inset). Lubricate friction surface with transmission lube and install 5th-6th speed synchronizer assembly and 6th speed synchronizer cup.

REASSEMBLY - TRANSMISSION



21. Using a sleeve type driver install front mainshaft bearing. Install snap ring in groove on end of shaft (inset).

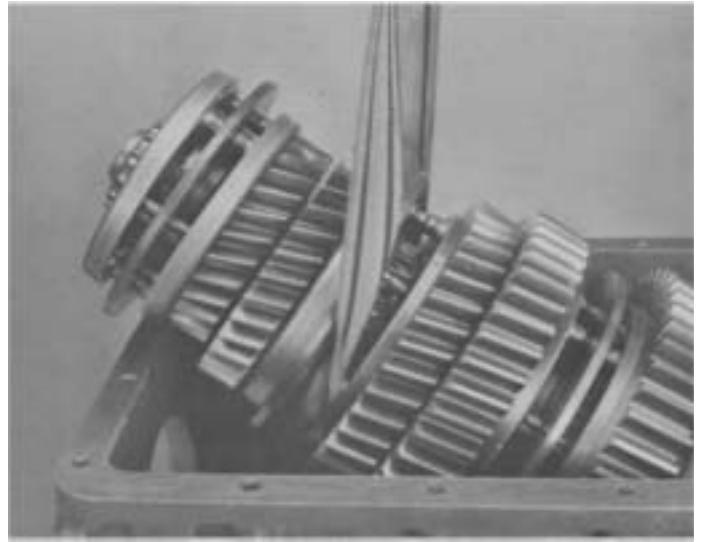

23. Using a sling around the 3rd-4th synchronizer carefully lower mainshaft into case.

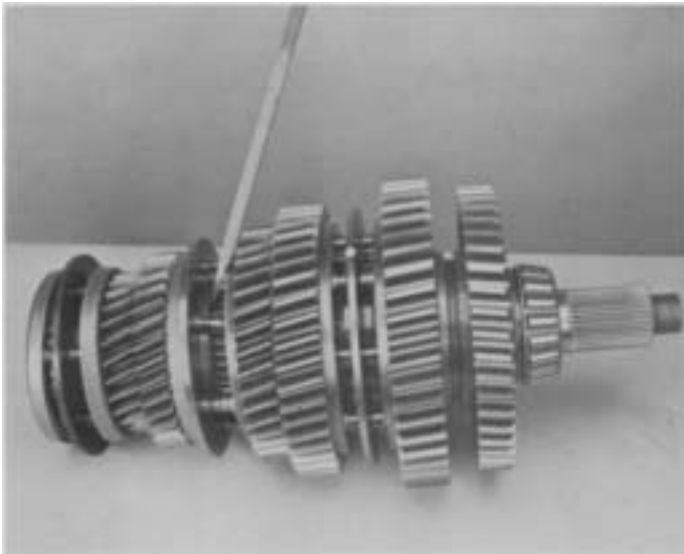

22. Remove mainshaft assembly from vise and place on bench. Shift synchronizer into 4th gear.



24. Using a sleeve type driver install bearing on input shaft.

REASSEMBLY - TRANSMISSION

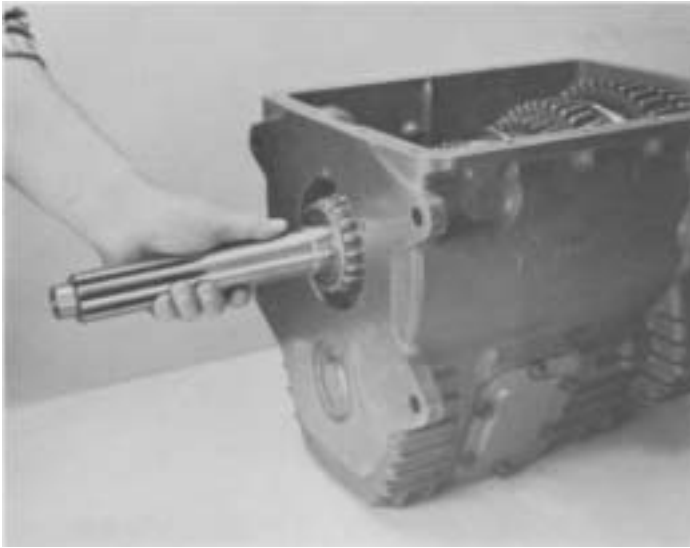

49-25

25. Install input shaft by aligning clutching teeth on main drive gear with teeth in 5th speed synchronizer cup.

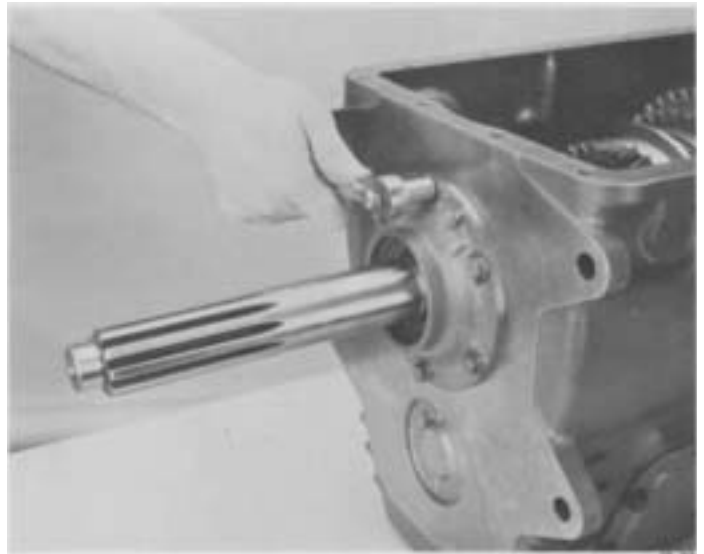

27. Install input shaft bearing cover and gasket. Apply Loctite 262 to threads of capscrews and torque to 15-20 lbs. ft. (20-27 Nm)



49-26

26. Coat outer diameter of input shaft bearing cover oil seal with Loctite 510. Install seal with flanged driver as shown. Install input shaft bearing race (inset).

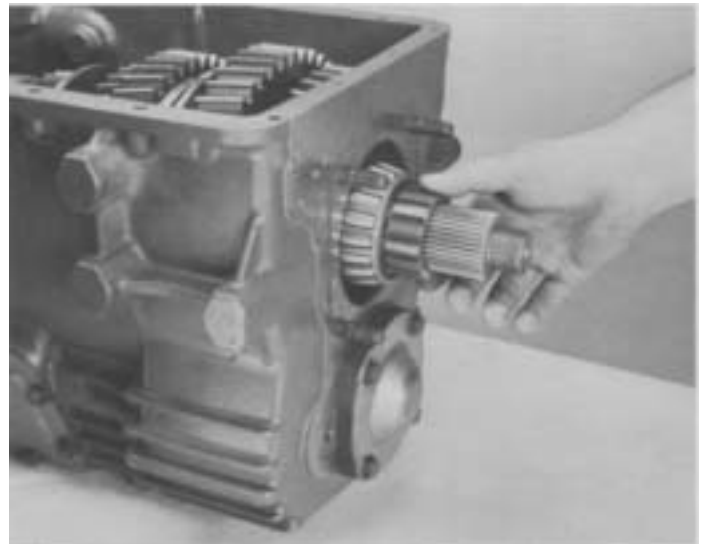

49-28

28. Install speedometer drive gear or rotor on output shaft.

REASSEMBLY - TRANSMISSION

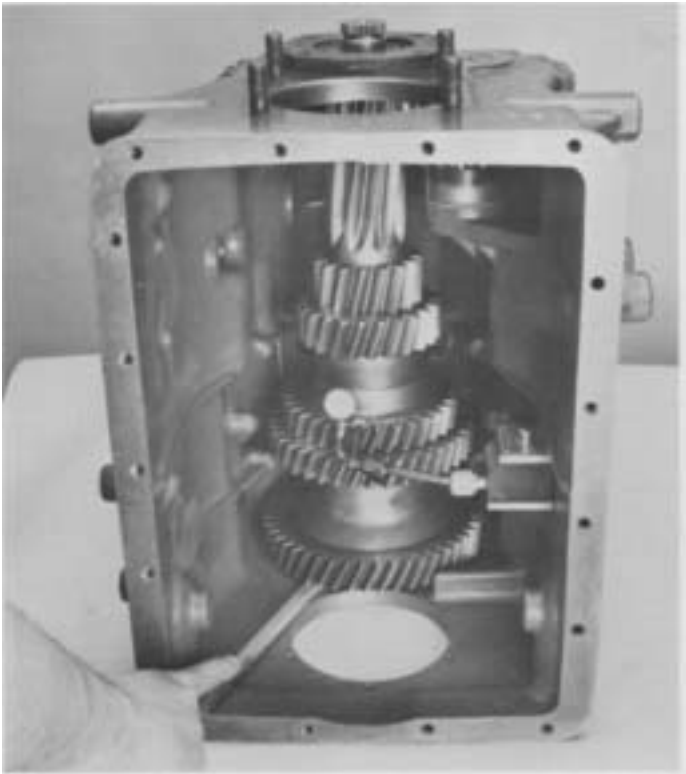

16. Rotate countershaft to seat bearings and races. Position dial indicator as shown, lift countershaft to measure end play. End play must be set at .006-.010 (0.15-0.25 mm). Add shims for more end play and remove shims for less end play.

NOTE: Once end play is correct remove retainer and apply a light coat of Loctite 510 to both sides of shims and face of retainer.

Coat threads of set screws with Loctite 262 and retorque.

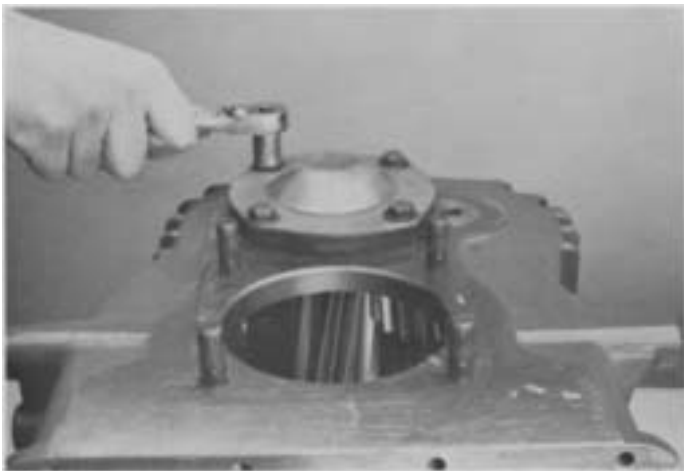

17. Install countershaft rear bearing cover and gasket. Coat threads of capscrews with Loctite 262 and torque to 20-30 lbs. ft. (27-41 Nm).
Tip transmission to horizontal position to install mainshaft.

REASSEMBLY - TRANSMISSION

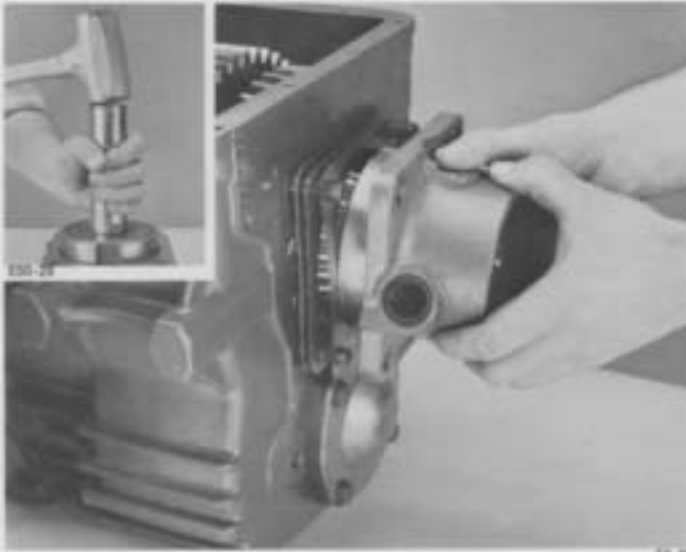

29. If necessary install rear bearing race (inset). Temporarily install shims and rear bearing cover. Tighten nuts to 60-70 lbs. ft. (81-95 Nm).

NOTE: Top of rear bearing cover is marked for proper installation.



31. Position dial indicator as shown. Pry up on output shaft to measure end play. End play must be set at .006 -.010 (0.15-0.25 mm rein). Add shims for more end play, remove shims for less end play.

NOTE: Once end play is correct remove yoke and rear bearing cover and apply a light coat of Loctite 510 to both sides of shims.



30. Place transmission in a vertical position as shown. Install yoke and nut. Torque yoke nut to 300-350 lbs. ft. (407-475 Nm). Rotate input shaft and mainshaft to seat bearings and races.



32. Install rear seal using a flanged driver.

REASSEMBLY - TRANSMISSION

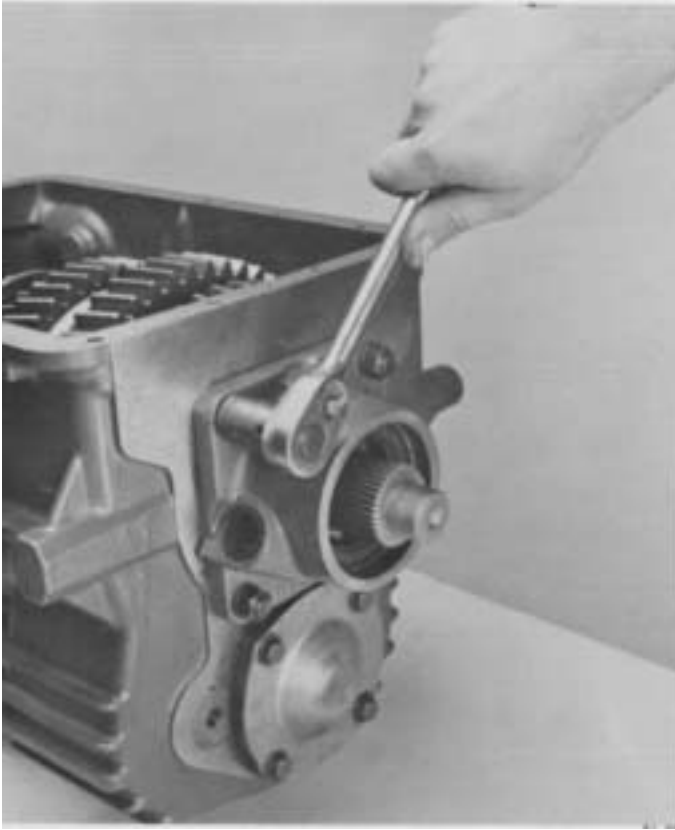

33. Install rear bearing cover. Tighten nuts to 60-70 lbs. ft. (81-95 Nm). Top of rear bearing cover is marked for proper installation.

INSTALLATION-CLUTCH HOUSING AND YOKE

A. Installation of Clutch Housing

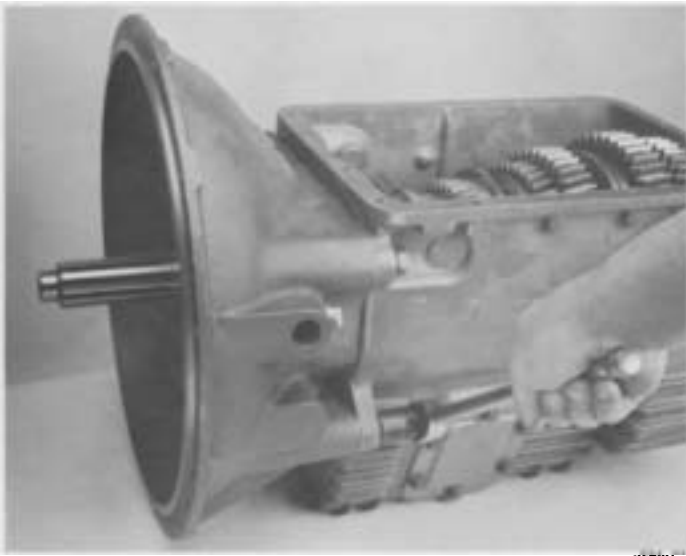

1. Position clutch housing on front of transmission. Install four retaining bolts and torque to 145-155 lbs. ft. (196-210 Nm).

B. Installation of Yoke

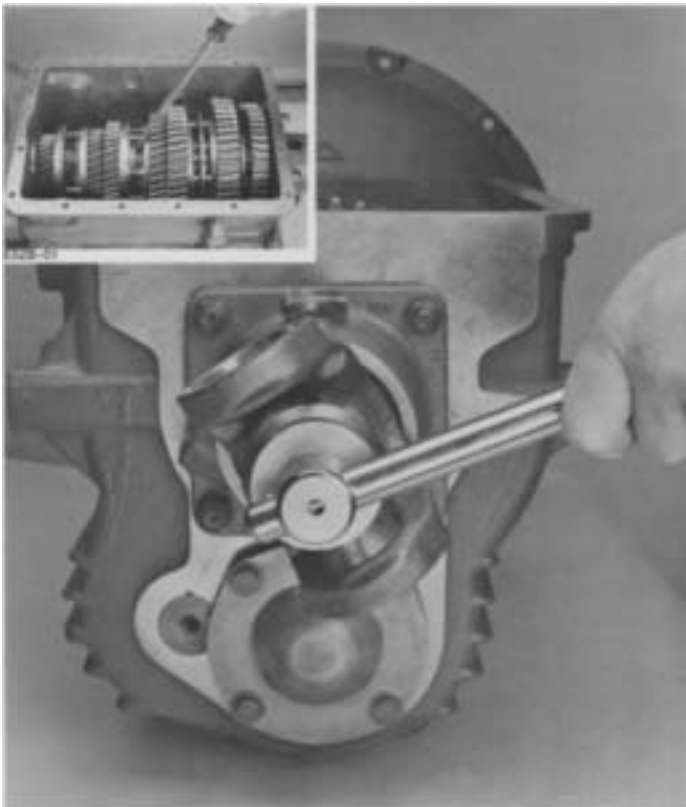

1. Lock the transmission by engaging two mainshaft gears (inset). Carefully install yoke and nut. Tighten nut to 300-350 lbs. ft (407-475 Nm).

INSTALLATION-SHIFTING CONTROLS

A. Shift Bar Housing Assembly

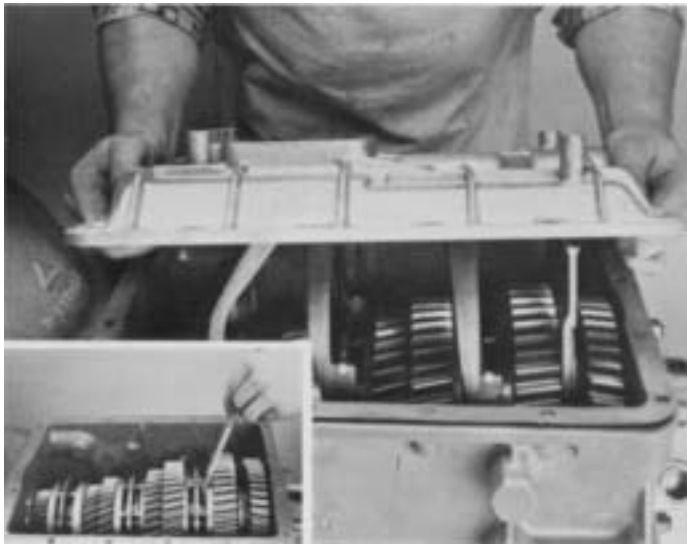

1. Place transmission in neutral (inset) and install gasket on case. Place shift bar housing in neutral and install on case making sure shift yokes align with corresponding synchronizers and sliding clutch.

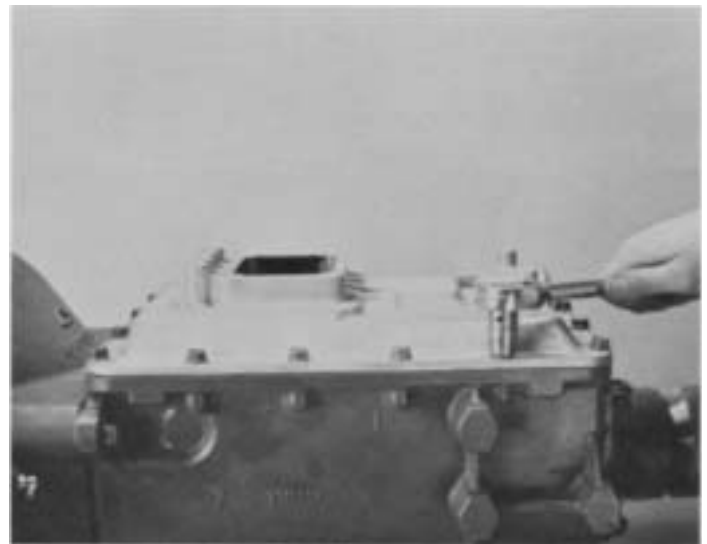

3. Apply Loctite 262 to threads of cap screws. Install cap screws into housing and torque to 20-25 lbs. ft (27-34 Nm).

53-03

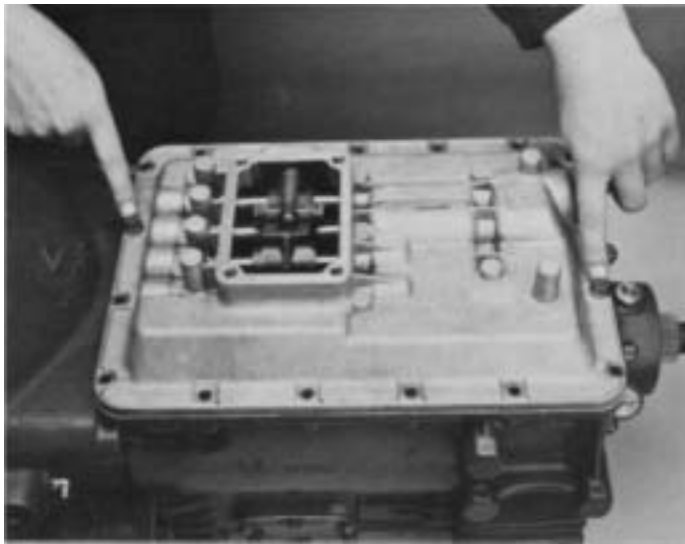

2. Apply Loctite 262 to threads and install two shift bar housing cap screws in alignment holes as shown. Install front cap screw first then rear.

INSTALLATION-SHIFTING CONTROLS

B. Gear Shift Lever Housing Assembly

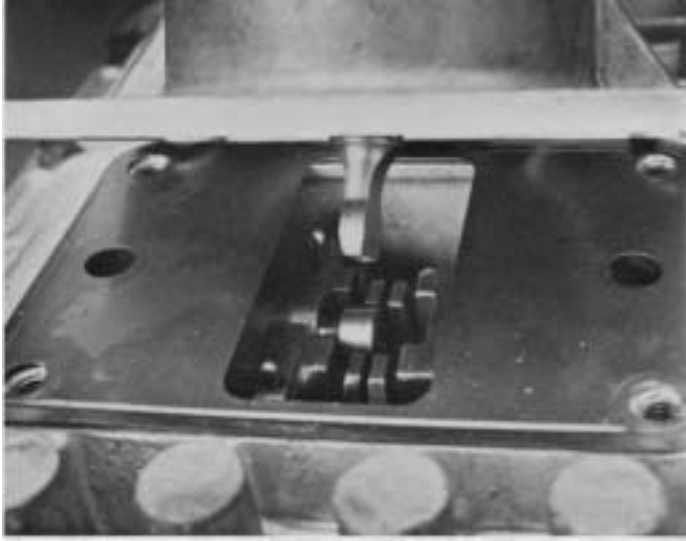

1. With the shift bar housing in the neutral position, install gasket and gear shift lever assembly on the shift bar housing. Fit gear shift lever in corresponding finger assembly in bar housing as lever is installed.

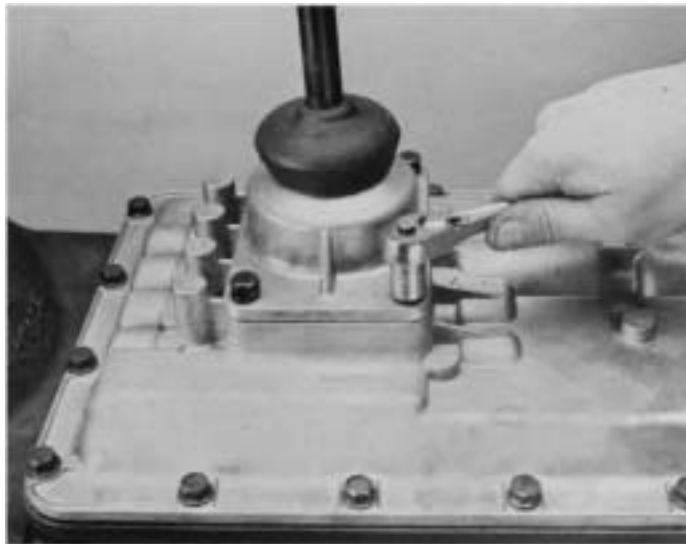

2. Coat threads of retaining capscrews with Loctite 262 and install. Torque capscrews to 20-25 lbs. ft. (27-34 Nm).

Copyright Eaton Corporation, 2012. Eaton hereby grant their customers, vendors, or distributors permission to freely copy, reproduce and/or distribute this document in printed format. It may be copied only in its entirety without any changes or modifications. THIS INFORMATION IS NOT INTENDED FOR SALE OR RESALE, AND THIS NOTICE MUST REMAIN ON ALL COPIES.

Note: Features and specifications listed in this document are subject to change without notice and represent the maximum capabilities of the software and products with all options installed. Although every attempt has been made to ensure the accuracy of information contained within, Eaton makes no representation about the completeness, correctness or accuracy and assumes no responsibility for any errors or omissions. Features and functionality may vary depending on selected options.

For spec'ing or service assistance, call 1-800-826-HELP (4357) or visit www.eaton.com/roadranger. In Mexico, call 001-800-826-4357.

Roadranger: Eaton and trusted partners providing the best products and services in the industry, ensuring more time on the road.

Eaton Corporation

Vehicle Group
P.O. Box 4013
Kalamazoo, MI 49003 USA
800-826-HELP (4357)
www.eaton.com/roadranger

Printed in USA

For parts or service call us
Pro Gear & Transmission, Inc.



1 (877) 776-4600

(407) 872-1901

parts@eprogear.com

906 W. Gore St.

Orlando, FL 32805

