

# Fuller Mid Range Transmissions TRSM0170

October 2007



*Powering Business Worldwide*

BACKED BY

**Roadranger**

SUPPORT

For parts or service call us  
Pro Gear & Transmission, Inc.



**1 (877) 776-4600**

**(407) 872-1901**

**parts@eprogear.com**

**906 W. Gore St.**

**Orlando, FL 32805**





# TABLE OF CONTENTS

---

FOREWORD .....	2
MODEL DESIGNATIONS AND SPECIFICATIONS .....	3
LUBRICATION .....	4
OPERATION .....	6
POWER FLOW .....	7
TORQUE RECOMMENDATIONS .....	8
TOOL REFERENCE .....	10
PREVENTIVE MAINTENANCE .....	11
PRECAUTIONS	
DISASSEMBLY .....	13
INSPECTION .....	13
REASSEMBLY .....	15
DISASSEMBLY AND REASSEMBLY—SHIFTING CONTROLS	
GEARSHIFT LEVER HOUSING ASSEMBLY .....	16
SHIFT BAR HOUSING ASSEMBLY .....	19
REMOVAL—REAR YOKE AND CLUTCH HOUSING .....	26
DISASSEMBLY—TRANSMISSION .....	28
REASSEMBLY—TRANSMISSION .....	39
INSTALLATION—REAR YOKE AND CLUTCH HOUSING .....	54
INSTALLATION—SHIFTING CONTROLS	
SHIFT BAR HOUSING ASSEMBLY .....	55
GEARSHIFT LEVER HOUSING ASSEMBLY .....	56
OPTIONS .....	57



# FOREWORD

---

This manual is designed to provide detailed information necessary to service and repair the Fuller® Transmission listed on the cover.

As outlined in the Table of Contents, the manual is divided into 3 main sections:

- a. Technical information and reference
- b. Removal, disassembly, reassembly and installation
- c. Options

The format of the manual is designed to be followed in its entirety if complete disassembly and reassembly of the transmission is necessary. But if only one component of the transmission needs to be repaired, refer to the Table of Contents for the page numbers showing that component. For example, if you need to work on the Shift Bar Housing, you will find instructions for removal, disassembly and reassembly on page 19. Instructions for installation are on page 55. Service Manuals, Illustrated Parts Lists, Drivers Instructions, and other forms of product

service information for these and other Fuller Transmissions are available upon request. A Technical Literature Order Form may be found in the back of this manual\*. You may also obtain Service Bulletins, detailing information on product improvements, repair procedures and other service-related subjects by writing to the following address:

EATON CORPORATION  
TRANSMISSION DIVISION  
Technical Service Department  
P.O. Box 4013  
Kalamazoo, Michigan 49003  
(616) 342-3344

Every effort has been made to ensure the accuracy of all information in this brochure. **However, Eaton Transmission Division makes no expressed or implied warranty or representation based on the enclosed information.** Any errors or omissions may be reported to Training and Publications, Eaton Transmission Division, P.O. Box 4013, Kalamazoo, MI 49003.

# MODEL DESIGNATIONS AND SPECIFICATIONS

## Nomenclature:

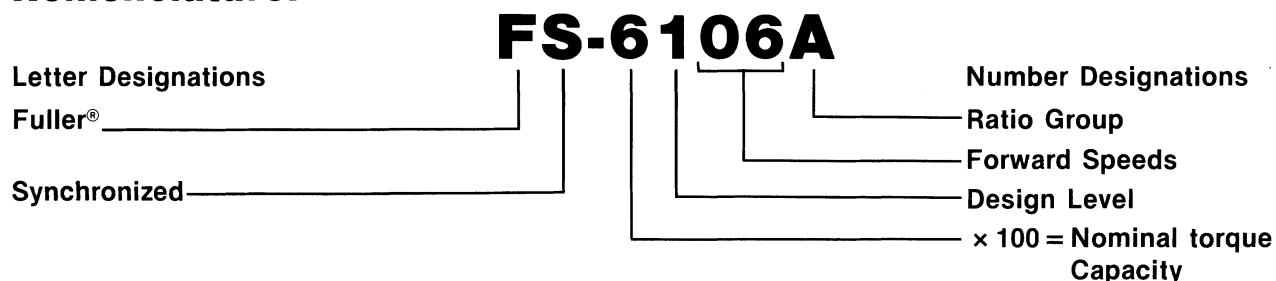

**IMPORTANT:** All Fuller Transmissions are identified by model and serial number. This information is stamped on the transmission identification tag and affixed to the case.  
DO NOT REMOVE OR DESTROY THE TRANSMISSION IDENTIFICATION TAG.

## Specifications:

Models	No. No. Spds.	Gear Ratios							Relative Speed PTO Gear To Input R.P.M.	1 Length In. (mm)	2 Weight Lbs. (Kg.)	3 Oil Cap. Pints (Liters)
		1st	2nd	3rd	4th	5th	6th	Reverse				
FS-6106A	6	9.00	5.01	2.96	1.89	1.32	1.00	8.00	454	28.46 (722.9)	418 (189.6)	19 (9)

See Chart Notes.

### CHART NOTES:

- 1 Lengths measured from face of clutch housing to front bottoming surface of companion flange or yoke.
- 2 **Weight** — Listed weights are *without* clutch housing\* and include standard controls, which consist of gear shift lever housing and gear shift lever. Weight of standard controls is approximately 10 lbs. (4.5 kg). All weights are approximate.
- 3 Oil Capacities are approximate, depending on inclination of engine and transmission. Always fill transmission with proper grade and type of lubricant to level of filler opening. See LUBRICATION.

\* For information on available clutch housings refer to Publication FUL-140 — “Clutch Housing Chart”.

# LUBRICATION

## Proper Lubrication... the Key to long transmission life

Proper lubrication procedures are the key to a good all-around maintenance program. If the oil is not doing its job, or if the oil level is ignored, all the maintenance procedures in the world are not going to keep the transmission running or assure long transmission life.

Fuller® Transmissions are designed so that the internal parts operate in a bath of oil circulated by the motion of gears and shafts. Grey iron parts have built-in channels where needed, to help lubricate bearings and shafts.

Thus, all parts will be amply lubricated if these procedures are closely followed:

1. **Maintain oil level. Inspect regularly.**
2. **Change oil regularly.**
3. **Use the correct grade and type of oil.**
4. **Buy from a reputable dealer.**

Lubrication Change and Inspection	
HIGHWAY USE	
First 3,000 to 5,000 miles (4827 to 8045 Km)	Change transmission oil on new units
Every 10,000 miles (16090 Km)	Inspect oil level. Check for leaks.
Every 50,000 miles (80450 Km)	Change transmission oil.

## Oil is Important...

Here are some of the functions oil must perform:

- Provide a protective film—To protect surface of heavily loaded parts such as gear teeth and bearings, thus preventing metal to metal contact which causes scoring, scuffing and seizure.
- Act as a coolant—To dissipate heat and reduce heat by reducing friction.
- Afford sufficient fluidity—To follow, coat and cushion all loaded surfaces.
- Be chemically stable—To withstand heat and agitation without separation, gumming-up, oxidizing or corroding.
- Be non-foaming—To prevent excessive foam and increased volume under severe conditions.
- Be free of sediment and water—To prevent sludge and rust.

Recommended Lubricants		
Type	Grade (SAE)	Fahrenheit (Celsius) Ambient Temperature
Heavy Duty Engine Oil MIL-L-2104B, C, or D or API-SF or API-CD (Previous API designations acceptable)	50 40 30	Above 10°F(-12°C) Above 10°F(-12°C) Below 10°F(-12°C)
Mineral Gear Oil with rust and oxidation inhibitor API-GL-1	90 80W	Above 10°F(-12°C) Below 10°F(-12°C)
*Mild EP Gear Oil MIL-L-2105 or API-GL-4	90 80W	10°F(-12°C) to 100°F(38°C) -15°F(-26°C) to 70°F(21°C)
*Multipurpose Gear Oil MIL-L-2105B or MIL-L-2105C or API-GL-5	85W140 80W140 90 80W90 80W 75W	Above 10°F(-12°C) Above -15°F(-26°C) 10°F(-12°C) to 100°F(38°C) -15°F(-26°C) to 100°F(38°C) -15°F(-26°C) to 70°F(21°C) -40°F(-40°C) to -15°F(-26°C)

Additives, friction modifiers or synthetic lubricants are not recommended for use in Fuller Transmissions.

\*Mild EP Gear Oil or Multi-Purpose Gear Oil are not recommended when lubricant operating temperatures are above 230°F (110°C).

# LUBRICATION

---

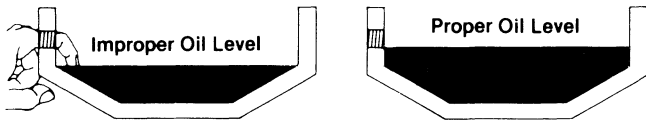

## Proper Oil Level

Make sure oil is level with filler opening. Because you can reach oil with your finger does not mean oil is at proper level. **One inch of oil level is about one gallon of oil.** The FS-6106 is equipped with a dip stick which may also be used to check oil level.

## Draining Oil

Drain transmission while oil is warm. To drain oil remove the drain plug at bottom of case. Clean the drain plug before re-installing.

## Refilling

Clean case around filler plug and remove plug from side of case. Fill transmission to the level of the filler opening.

The exact amount of oil will depend on the transmission inclination and model. *In every instance, fill to the level of the filler opening.*

Do not over fill—this will cause oil to be forced out of the case through front bearing cover.

**When adding oil, types and brands of oil should not be intermixed because of possible incompatibility.**

## Operating Temperatures

The transmission should not be operated consistently at temperatures above 250°F (120°C). However, intermittent operating temperatures to 300°F (149°C) will not harm the transmission. Operating temperatures above 250°F increase the lubricant's rate of oxidation and shorten its effective life. When the transmission is operated intermittently above 250°, heavy duty engine oil provides the best oxidation resistance. When the average operating temperature is above 250°F, the transmission may require more frequent oil changes or external cooling.

The following conditions in any combination can cause operating temperatures of over 250°F: (1) operating consistently at slow speeds, (2) high ambient temperatures, (3) restricted air flow around transmission, (4) exhaust system too close to transmission, (5) high horsepower, overdrive operation.

# OPERATION

## Gear Shift Lever Pattern and Shifting Instructions

Follow the simple 6-speed shift pattern . . .

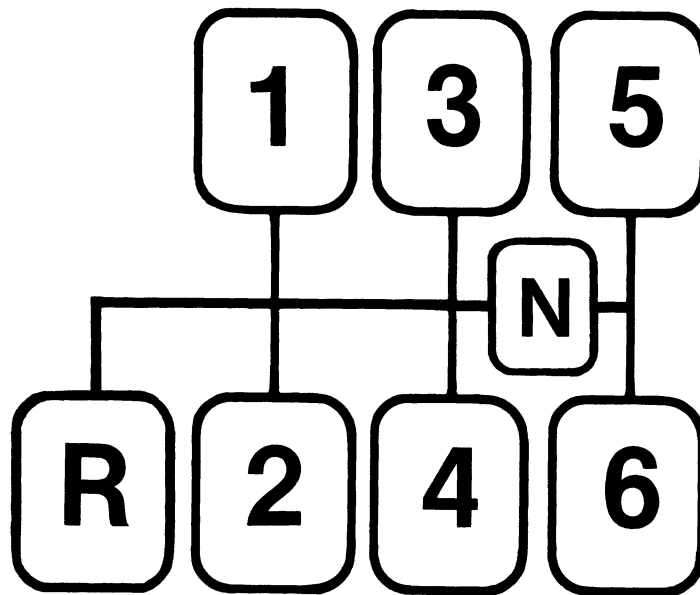

### General Information

FS-6106A transmissions have six forward speeds and one reverse, and are shifted as you would shift any synchronized manual transmission, following the simple 6-speed shift pattern.

### Driving Tips

- Always use the clutch when making upshifts or downshifts. Premature synchronizer failure can result from not using the clutch.
- Always select a starting gear that will provide sufficient reduction for the load and terrain.
- Never downshift at too high of a road speed.
- Never slam or jerk the shift lever to complete gear engagement.
- Never coast with the transmission in neutral and the clutch dis-engaged.

# POWER FLOW

The transmission must efficiently transfer the engine's power, in terms of torque, to the vehicle's rear wheels. Knowledge of what takes place in the transmission during torque transfer is essential when trouble-shooting and when making repairs become necessary.

1. Power (torque) from the engine is transferred to the input shaft and drive gear.
2. Torque is transferred to countershaft drive gear.
3. Torque is delivered along countershaft to all countershaft gears.
4. Torque is transferred to "engaged" mainshaft gear. The cross section illustrates 1st speed gear position.
5. Internal clutching teeth of engaged mainshaft gear transfers torque to mainshaft through synchronizer assembly.
6. Mainshaft transfers torque directly to driveshaft through rear yoke.

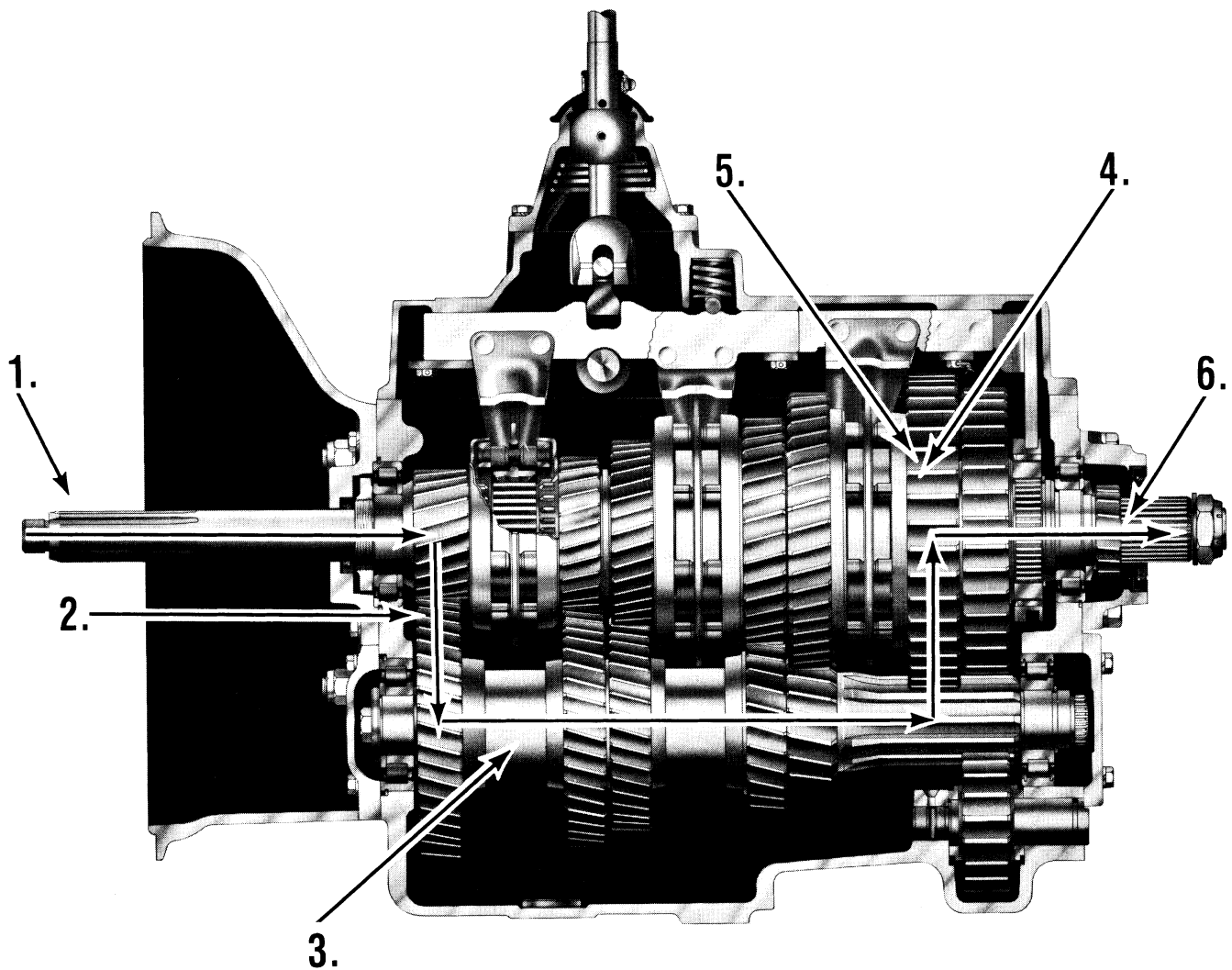

# TORQUE RECOMMENDATIONS

Correct torque application is extremely important to assure long transmission life. Over-tightening or under-tightening of fasteners can result in a loose installation and, in many instances, eventually cause damage to the transmission. Use a torque wrench to attain recommended torque ratings. Do not torque capscrews dry.

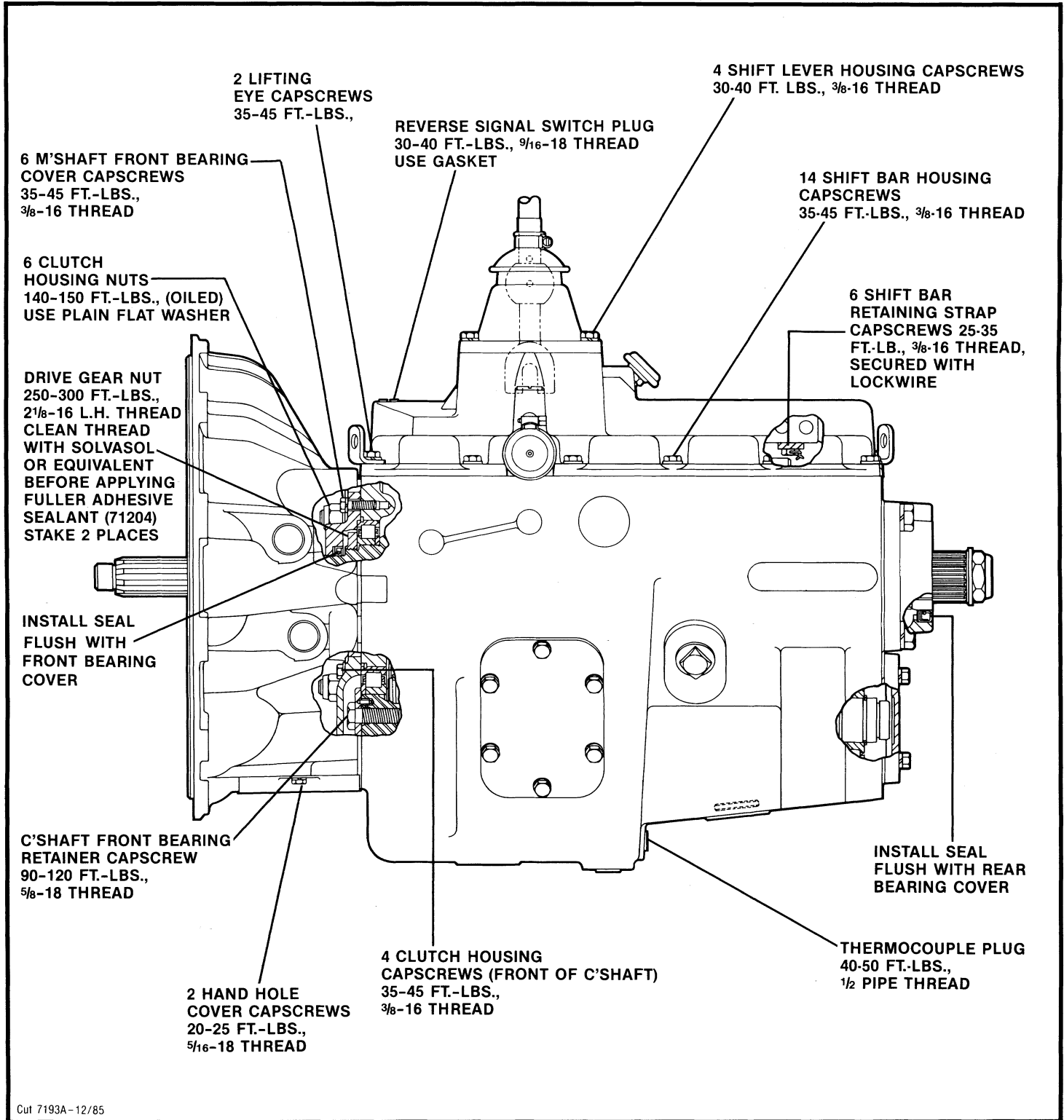

Cut 7193A-12/85

# TORQUE RECOMMENDATIONS

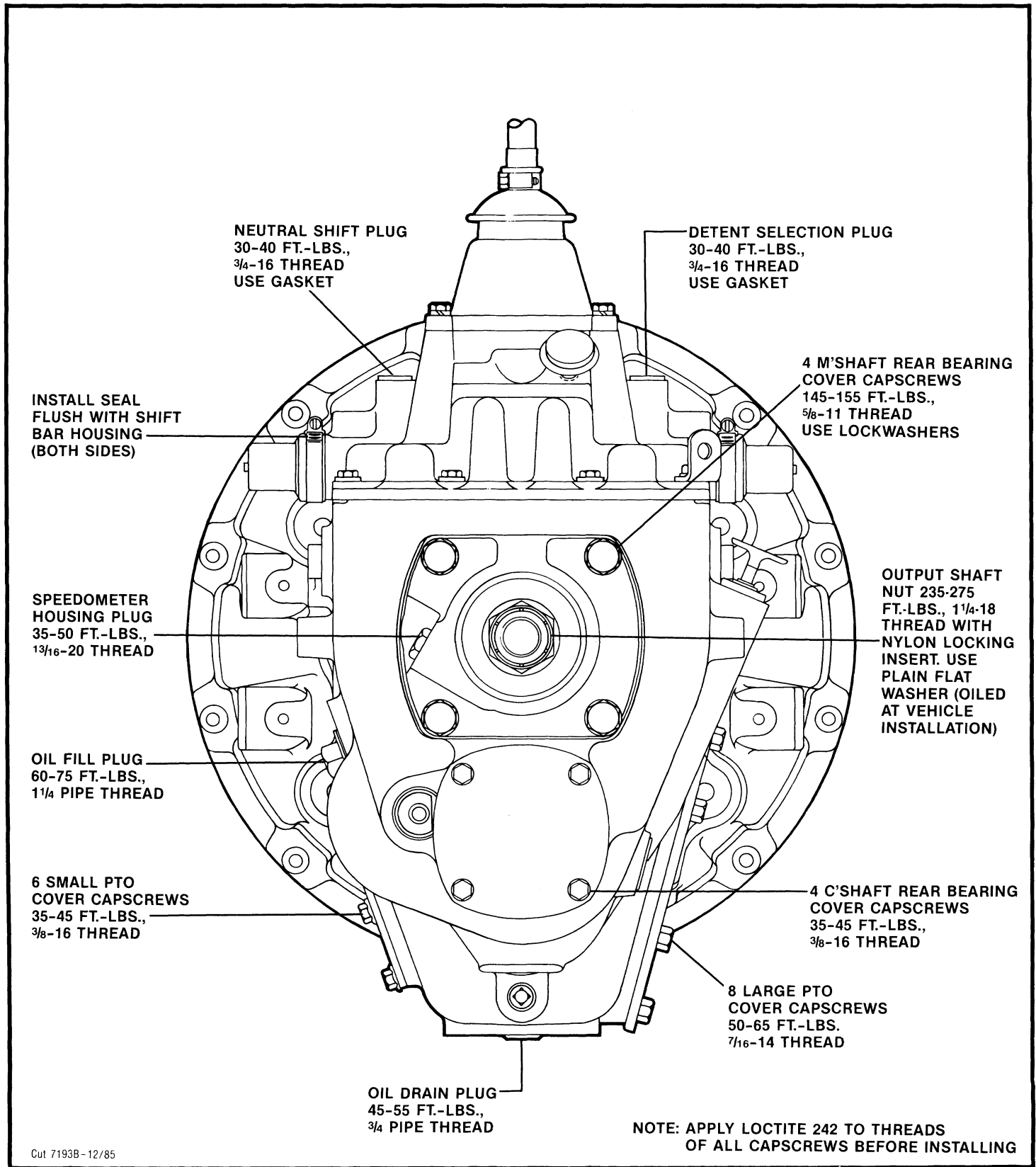

Cut 7193B - 12/85



# TOOL REFERENCE

Some repair procedures pictured in this manual show the use of specialized tools. Their actual use is recommended as they make transmission repair easier, faster, and prevent costly damage to critical parts.

But for the most part, ordinary mechanic's tools such as socket wrenches, screwdrivers, etc., and other standard shop items such as a press, mauls and soft bars are all that is needed to successfully disassemble and reassemble any Fuller Transmission.

The specialized tools listed below can be obtained from a tool supplier or made from dimensions as required by the individual user. Detailed Fuller Transmission Tool Prints are available upon request by writing.

Eaton Corporation  
Transmission Division  
Technical Service Dept.  
P.O. Box 4013  
Kalamazoo, Michigan 49003

PAGE	TOOL	HOW OBTAINED
18	Tension Spring Driver	Made from Fuller Transmission Print T-11938
35	Snap Ring Pliers	Tool Supplier
38	Impact Puller (1/2-13 Threaded End)	Tool Supplier
42	Countershaft Support Tool and Bearing Driver	Made from Fuller Transmission Print T-22913-C
50	Bearing Guide	Made from Fuller Transmission Print T-18042-110
51	Oil Seal Driver, Rear Bearing Cover	Made from Fuller Transmission Print T-18088-61
52	Input Shaft Nut Installer	Made from Fuller Transmission Print T-22553-A
52	Torque Wrench, 1000 Lbs./Ft. Capacity	Tool Supplier
53	Oil Seal Driver Front Bearing Cover (push type clutch)	Made from Fuller Transmission Print T-18088-67
53	Oil Seal Driver Front Bearing Cover (pull type clutch)	Made from Fuller Transmission Print T-18088-64

# PREVENTIVE MAINTENANCE

---

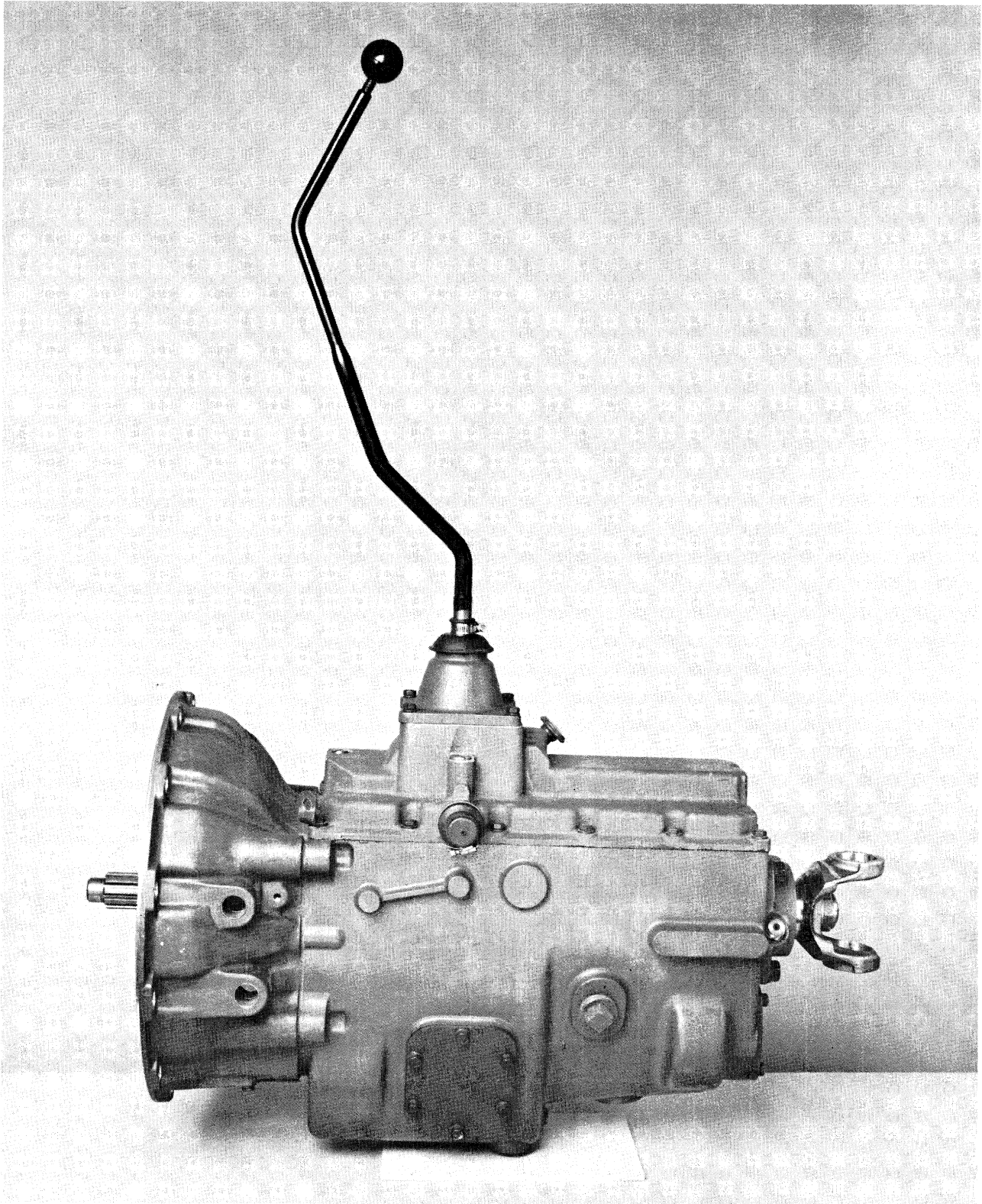

# PREVENTIVE MAINTENANCE

---

## PREVENTIVE MAINTENANCE CHECK CHART

### CHECKS WITHOUT PARTIAL DISASSEMBLY OF CHASSIS OR CAB

1. **Clutch Housing Mounting**
  - a. Check all capscrews in bolt circle of clutch housing for looseness.
2. **Clutch Release Bearing (Not Shown)**
  - a. Remove hand hole cover and check radial and axial clearance in release bearing.
  - b. Check relative position of thrust surface of release bearing with thrust sleeve on push-type clutches.
3. **Clutch Pedal Shaft and Bores**
  - a. Pry upward on shafts to check wear.
  - b. If excessive movement is found, remove clutch release mechanism and check bushings in bores and wear on shafts.
4. **Lubricant**
  - a. Change at specified service intervals.
  - b. Use only the types and grades as recommended. See LUBRICATION.
5. **Filler and Drain Plugs**
  - a. Remove filler plug or dip stick and check level of lubricant at specified intervals. Tighten filler and drain plugs securely.
6. **Capscrews and Gaskets**
  - a. Check all capscrews, especially those on PTO covers and rear bearing covers for looseness which would cause oil leakage. See TORQUE RECOMMENDATIONS.
  - b. Check PTO opening and rear bearing covers for oil leakage due to faulty gasket.
7. **Gear Shift Lever**
  - a. Check for looseness and free play in housing. If lever is loose in housing, proceed with Check No. 8.

8. **Gear Shift Lever Housing Assembly**
  - a. Remove the gear shift lever housing assembly from transmission.
  - b. Check tension spring and washer for set and wear.
  - c. Check bottom end of gear shift lever for wear of slots. Also check for wear of finger assembly.

### CHECKS WITH DRIVE LINE DROPPED

9. **Universal Joint Companion Flange or Yoke Nut**
  - a. Check for tightness. Tighten to recommended torque.
10. **Output Shaft (Not Shown)**
  - a. Pry upward against output shaft to check radial clearance in mainshaft rear bearing.

### CHECKS WITH UNIVERSAL JOINT COMPANION FLANGE OR YOKE REMOVED

**NOTE:** If necessary, use solvent and shop rag to clean sealing surface of companion flange or yoke. DO NOT USE CROCUS CLOTH, EMERY PAPER OR OTHER ABRASIVE MATERIALS THAT WILL MAR SURFACE FINISH.

11. **Splines on Output Shaft (Not Shown)**
  - a. Check for wear from movement and chucking action of the universal joint companion flange or yoke.
12. **Mainshaft Rear Bearing Cover**
  - a. Check oil seal for wear.

# PRECAUTIONS

---

## Disassembly

It is assumed in the detailed assembly instructions that the lubricant has been drained from transmission, the necessary linkage disconnected and the transmission has been removed from vehicle chassis. Removal of the gear shift lever housing assembly (or remote control assembly) is included in the detailed instructions (Disassembly and Reassembly—Shifting Controls); however, this assembly must be detached from shift bar housing before transmission can be removed.

**FOLLOW CLOSELY EACH PROCEDURE IN THE DETAILED INSTRUCTIONS, MAKING USE OF THE TEXT, ILLUSTRATIONS AND PHOTOGRAPHS PROVIDED.**

- 1. BEARINGS**—Carefully wash and relubricate all reusable bearings as removed and protectively wrap until ready for use. Remove bearings planned to be reused with pullers designed for this purpose.
- 2. ASSEMBLIES**—When disassembling the various assemblies, such as the mainshaft, countershafts, and shift bar housing, lay all parts on a clean bench in the same sequence as removed. This procedure will simplify reassembly and reduce the possibility of losing parts.
- 3. SNAP RINGS**—Remove snap rings with pliers designed for this purpose. Snap rings removed in this manner can be reused, if they are not sprung or loose.
- 4. CLEANLINESS**—Provide a clean place to work. It is important that no dirt or foreign material enters the unit during repairs. Dirt is an abrasive and can damage bearings. It is always good practice to clean the outside of the unit before starting the planned disassembly.
- 6. WHEN USING TOOLS TO MOVE PARTS**—Always apply force to shafts, housings, etc, with restraint. Movement of some parts is restricted. Never apply force to the part being driven after it stops solidly. The use of soft hammers, bars and mauls for all disassembly work is recommended.

## Inspection

Before reassembling the transmission, check each part carefully for abnormal or excessive wear and damage to determine reuse or replacement. When replacement is necessary, use only genuine Fuller Transmission parts to assure continued performance and extended life from your unit.

Since the cost of a new part is generally a small fraction of the total cost of downtime and labor, avoid reusing a questionable part which could lead to additional repairs and expense soon after initial reassembly. To aid in determining the reuse or replacement of any transmission part, consideration should also be given to the unit's history, mileage, application, etc.

Recommended inspection procedures are provided in the following checklist.

### A. BEARINGS

1. Wash all bearings in clean solvent. Check balls, rollers and raceways for pitting, discoloration, and spalled areas. Replace bearings that are pitted, discolored, spalled, or damaged during disassembly.
2. Lubricate bearings that are not pitted, discolored, or spalled and check for axial and radial clearances.
3. Replace bearings with excessive clearances.
4. Check bearing fits. Bearing inner races should be tight to shaft; outer races slightly tight to slightly loose in case bore. If bearing spins freely in bore, however, case should be replaced.

### B. GEARS

1. Check gear teeth for frosting and pitting. Frosting of gear tooth faces present no threat of transmission failure. Often in continued operation of the unit, frosted gears will “heal” and not progress to the pitting stage. And in most cases, gears with light to moderate pitted teeth have considerable gear life remaining and can be reused. But gears with advanced stage pitting should be replaced.
2. Check for gears with clutching teeth abnormally worn, tapered, or reduced in length from clashing in shifting. Replace gears found in any of these conditions.

# PRECAUTIONS

---

## Inspection (cont'd.)

3. Check axial clearance of gears. Where excessive clearance is found, check gear snap ring, split washer, clutch hub, and gear hub for excessive wear.

## C. SPLINES

1. Check splines on all shafts for abnormal wear. If sliding clutch gears, companion flange, or clutch hub have worn into the sides of the splines, replace the specific shaft affected.

## D. SPLIT WASHERS

1. Check surfaces of all washers. Washers scored or reduced in thickness should be replaced.

## E. REVERSE IDLER GEAR ASSEMBLIES

1. Check for excessive wear from action of roller bearings.

## F. GRAY IRON PARTS

1. Check all gray iron parts for cracks and breaks. Replace or repair parts found to be damaged. Heavy castings may be welded or brazed provided the cracks do not extend into bearing bores or bolting surfaces. When welding, however, never place the ground so as to allow current to pass through the transmission.

## G. CLUTCH RELEASE PARTS

1. Check clutch release parts. Replace yokes worn at cam surfaces and bearing carrier worn at contact pads.
2. Check pedal shafts. Replace those worn at bushing surfaces.

## H. SHIFT BAR HOUSING ASSEMBLY

1. Check for wear on shift yokes and finger assembly at pads and lever slot. Replace excessively worn parts.
2. Check yokes for correct alignment. Replace sprung yokes.
3. Check lockscrews in yokes assembly retainer plates. Tighten and rewire those found loose.

## I. GEAR SHIFT LEVER HOUSING ASSEMBLY

1. Check spring tension on shift lever. Replace tension spring if lever moves too freely.
2. If housing is disassembled, check bottom end of gear shift lever and shift finger assembly for wear. Replace both parts if excessively worn.

## J. BEARING COVERS

1. Check covers for wear from thrust of adjacent bearing. Replace covers damaged from thrust of bearing outer race.
2. Check bores of covers for wear. Replace those worn oversize.

## K. OIL SEALS

1. Check oil seal in input shaft and rear bearing cover. If sealing action of lip has been destroyed, replace seal.

## L. CLUTCHING TEETH

1. Check all shift yokes and yoke slots in sliding clutches for extreme wear or discoloration from heat.
2. Check engaging teeth for partial engagement pattern.

## M. SYNCHRONIZER ASSEMBLY

1. Check synchronizer for burrs, uneven and excessive wear at contact surface, and metal particles.
2. Check blocker pins for excessive wear or looseness.
3. Check synchronizer contact surfaces on the synchronizer cups for wear.

## N. O-RINGS

1. Check O-ring of idler shaft for cracks or cuts.

# PRECAUTIONS

---

## Reassembly

Make sure that interiors of case and housings are clean. It is important that dirt and other foreign materials be kept out of the transmission during reassembly. Dirt is an abrasive and can damage polished surfaces of bearings and washers. Use certain precautions, as listed below, during reassembly.

1. **GASKETS**—Use new gaskets throughout the transmission as it is being rebuilt. Make sure all gaskets are installed. An omission of any gasket can result in oil leakage or misalignment of bearing covers.
2. **CAPSCREWS**—To prevent oil leakage, use Loctite 242 thread sealant on all capscrews. For torque ratings, see TORQUE RECOMMENDATIONS.
3. **O-RINGS**—Lubricate O-rings with silicone lubricant.
4. **ASSEMBLY**—Refer to the illustrations provided in the detailed disassembly instructions as a guide to reassembly.
5. **INITIAL LUBRICATION**—Coat all thrust washers and synchronizers with transmission lubricant during reassembly to prevent scoring and galling of such parts.
6. **AXIAL CLEARANCES**—Maintain original axial clearances for mainshaft gears.
7. **BEARINGS**—Use of flanged-end bearing drivers is recommended for the installation of bearings. These drivers apply equal force to both bearing races, preventing damage to rollers and races while maintaining correct bearing alignment with bore and shaft. Avoid using a tubular or sleeve-type driver, whenever possible, as force is applied to only one of the bearing races. See TOOL REFERENCE.
8. **UNIVERSAL JOINT COMPANION FLANGE OR YOKE**—Pull the companion flange or yoke into place with the output shaft nut, using 235-275 foot-pounds of torque. Make sure the speedometer drive gear or a replacement spacer has been installed. Failure to properly torque the nut can result in damage to the mainshaft rear bearing.

**IMPORTANT: REFER TO THE APPROPRIATE ILLUSTRATED PARTS LIST (SPECIFIED BY MODEL SERIES) TO ENSURE THAT PROPER PARTS ARE USED DURING REASSEMBLY OF THE TRANSMISSION.**

# DISASSEMBLY AND REASSEMBLY SHIFTING CONTROLS

## GEARSHIFT LEVER HOUSING ASSEMBLY

### LEVER HOUSING ASSEMBLY

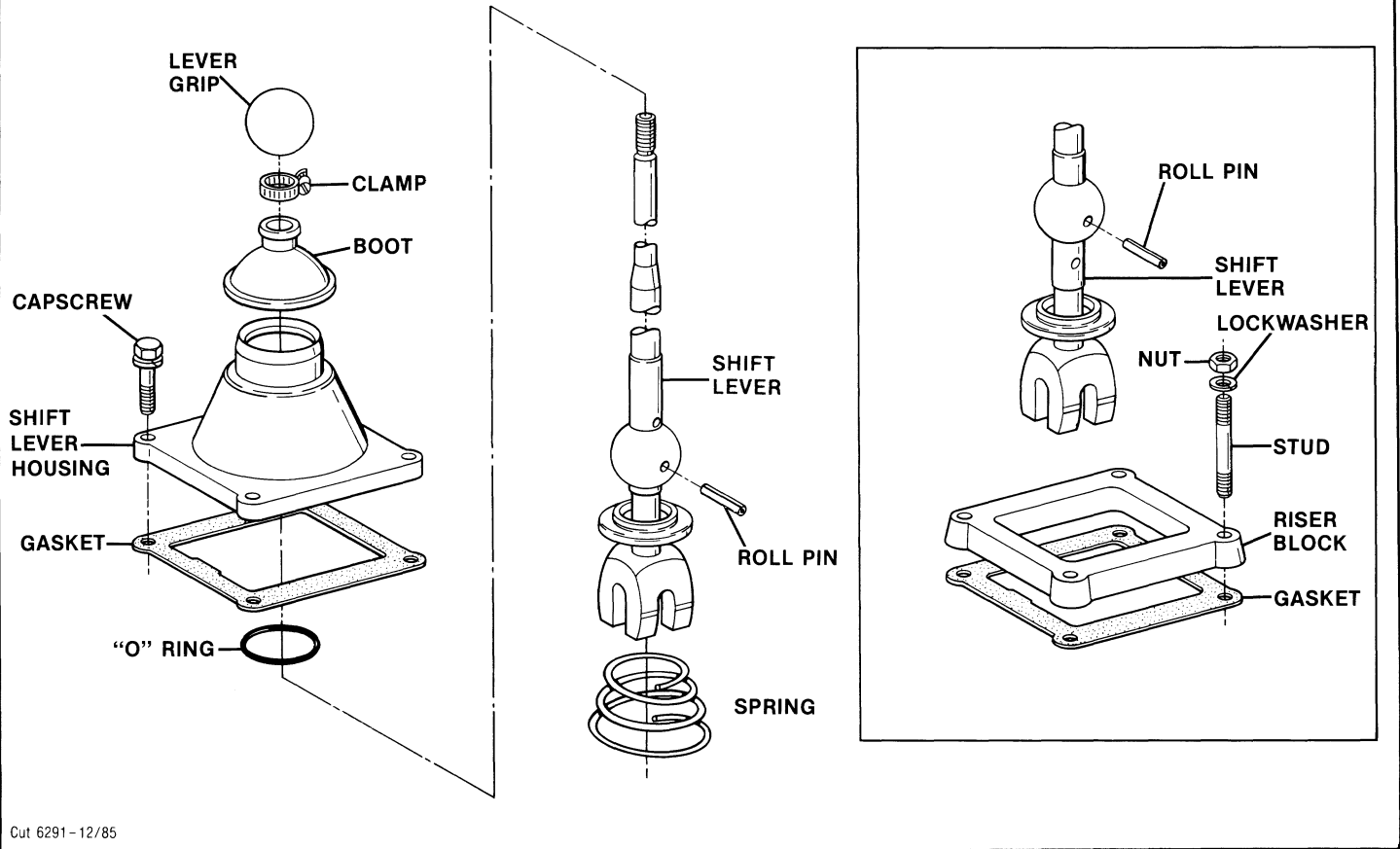

Cut 6291-12/85

### A. Removal and Disassembly

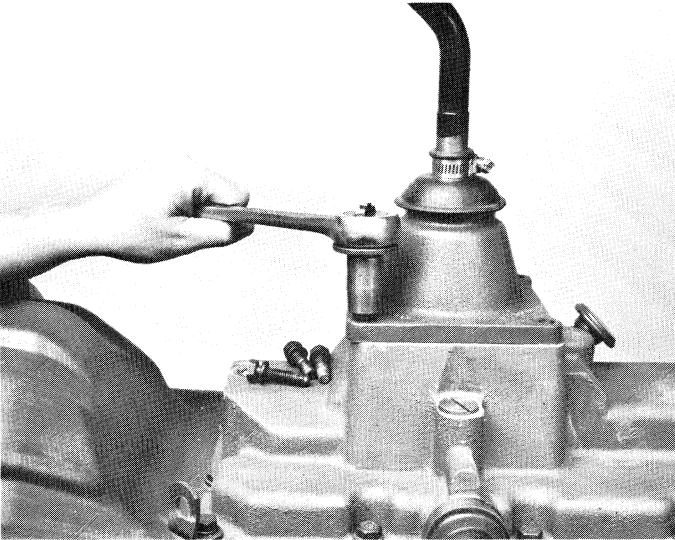

16-01

1. Turn out four cap screws and remove tower assembly from shift bar housing.

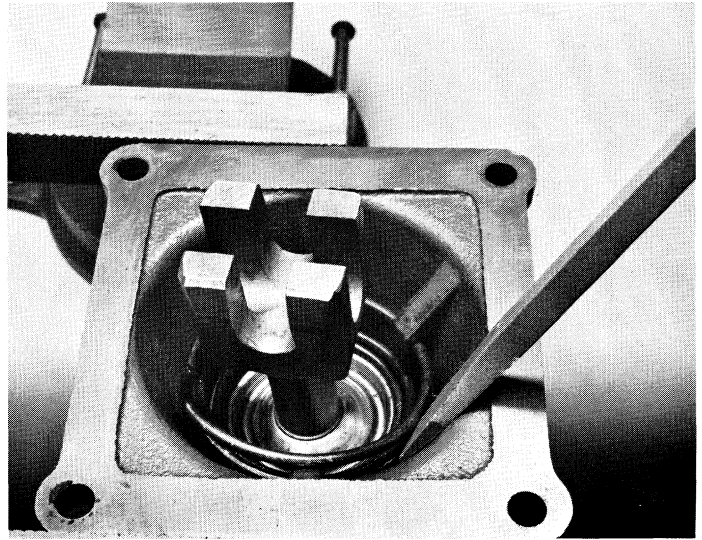

16-02

2. Remove boot and shift ball from gearshift lever and secure assembly in vise with bottom of housing up. Use a large screwdriver to twist between spring and housing, forcing spring from under lugs in housing. Do one coil at a time.



# DISASSEMBLY AND REASSEMBLY SHIFTING CONTROLS

## GEARSHIFT LEVER HOUSING ASSEMBLY (con't.)

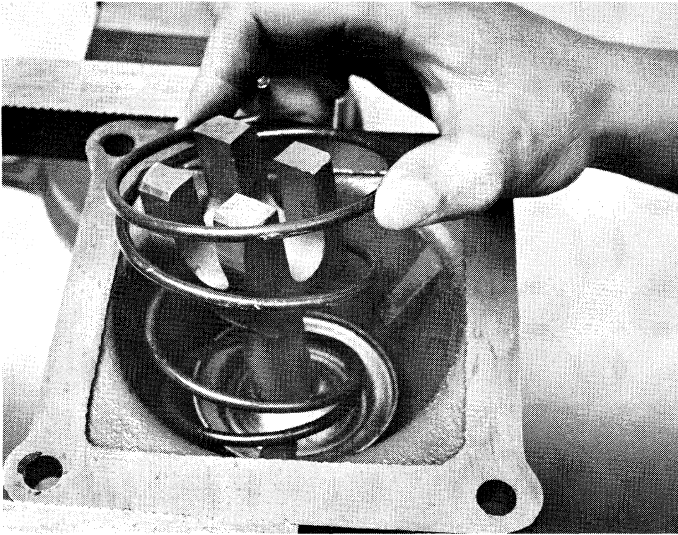

17-03

3. Remove tension spring. Remove washer and gearshift lever from housing.

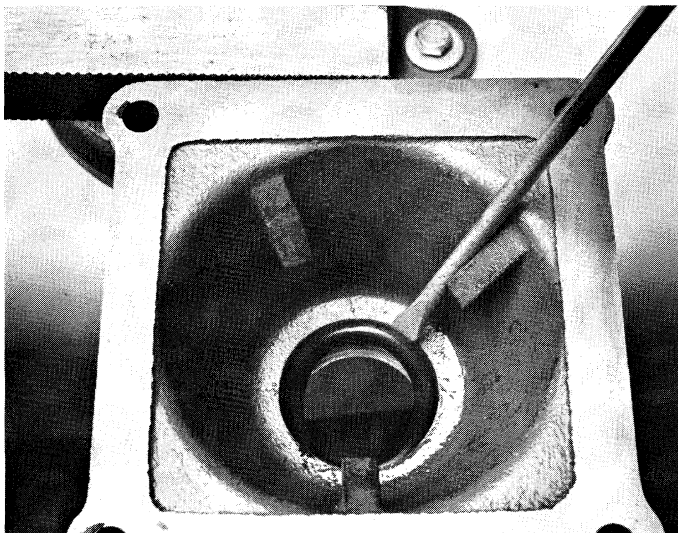

17-04

4. If necessary, remove the O-ring from groove inside tower.

### B. Reassembly of Gearshift Lever Housing Assembly

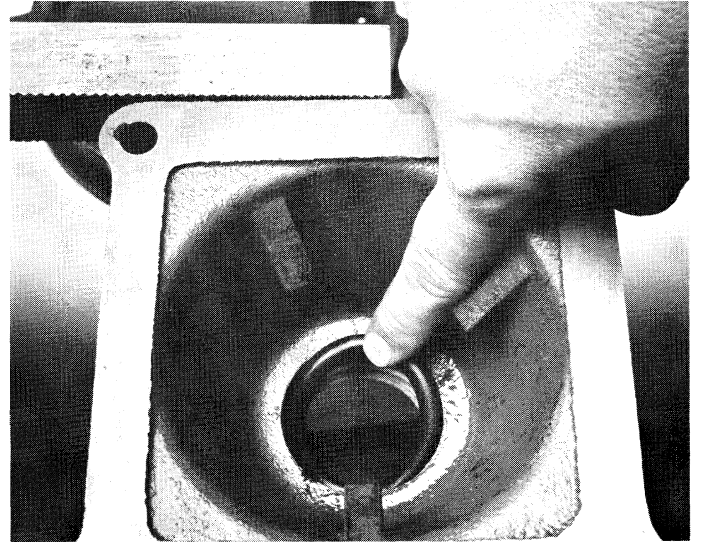

17-01

1. Secure gearshift housing in vise as during disassembly. Install O-ring in groove of tower.

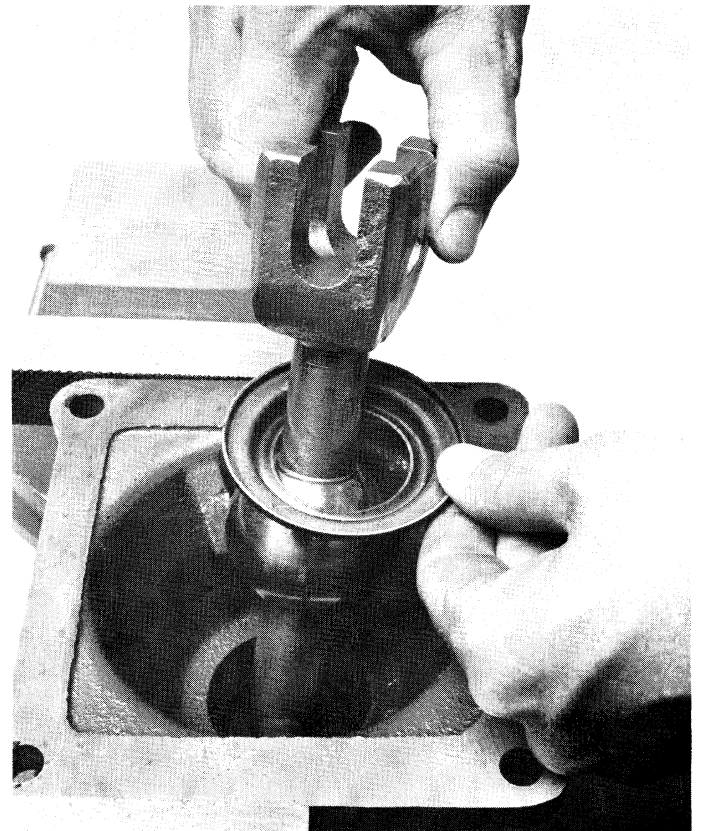

17-02

2. Position gearshift lever and washer in tower.



# DISASSEMBLY AND REASSEMBLY SHIFTING CONTROLS

## GEARSHIFT LEVER HOUSING ASSEMBLY (con't.)

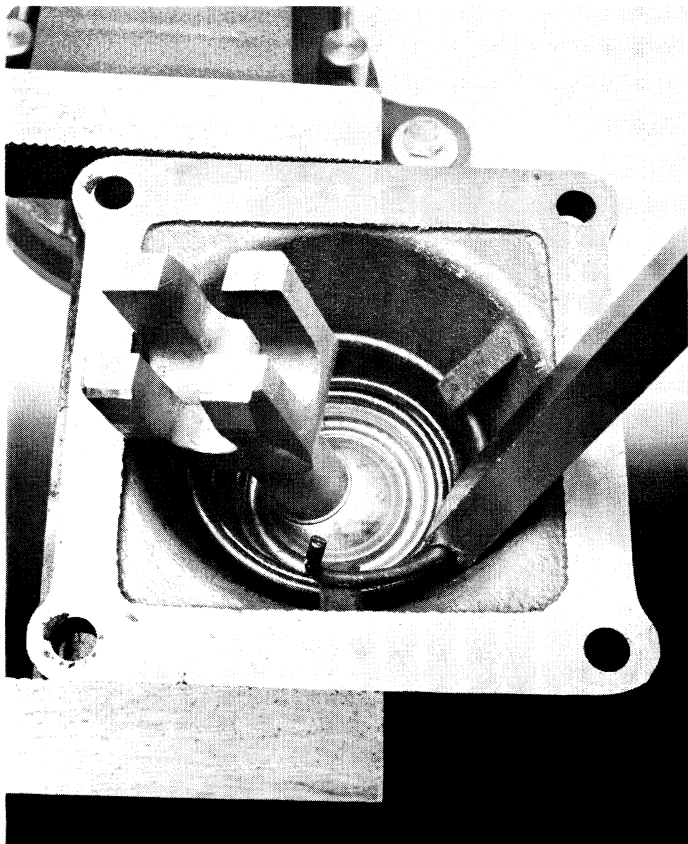

18-03

3. Install tension spring under lugs of housing, seating one coil at a time. Use of a spring driving tool is recommended.

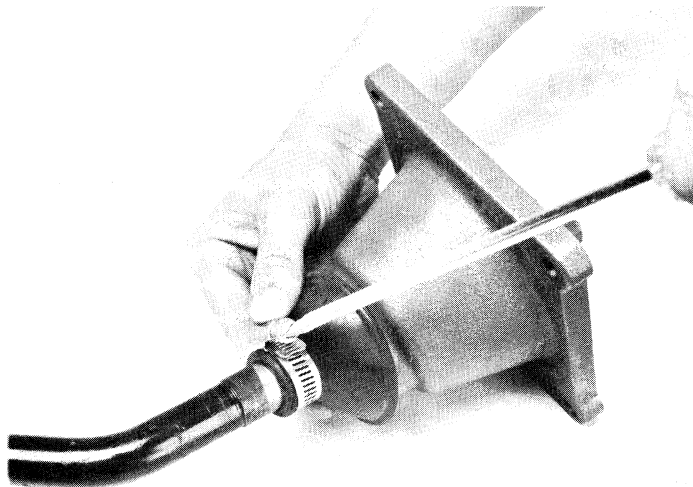

18-04

4. Remove assembly from vise and install rubber boot over gearshift lever and against housing. Install lever grip.

# DISASSEMBLY AND REASSEMBLY SHIFTING CONTROLS

## SHIFT BAR HOUSING ASSEMBLY

### A. Removal and Disassembly

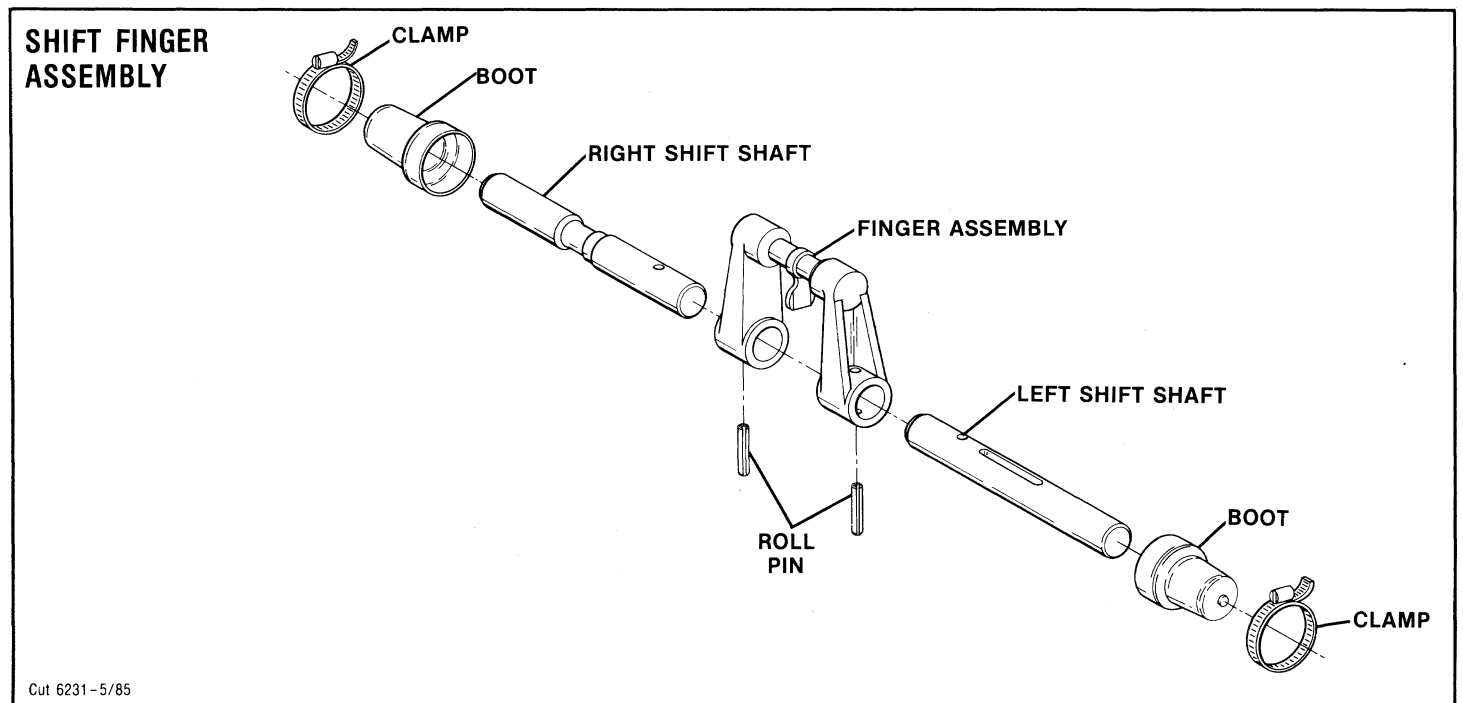
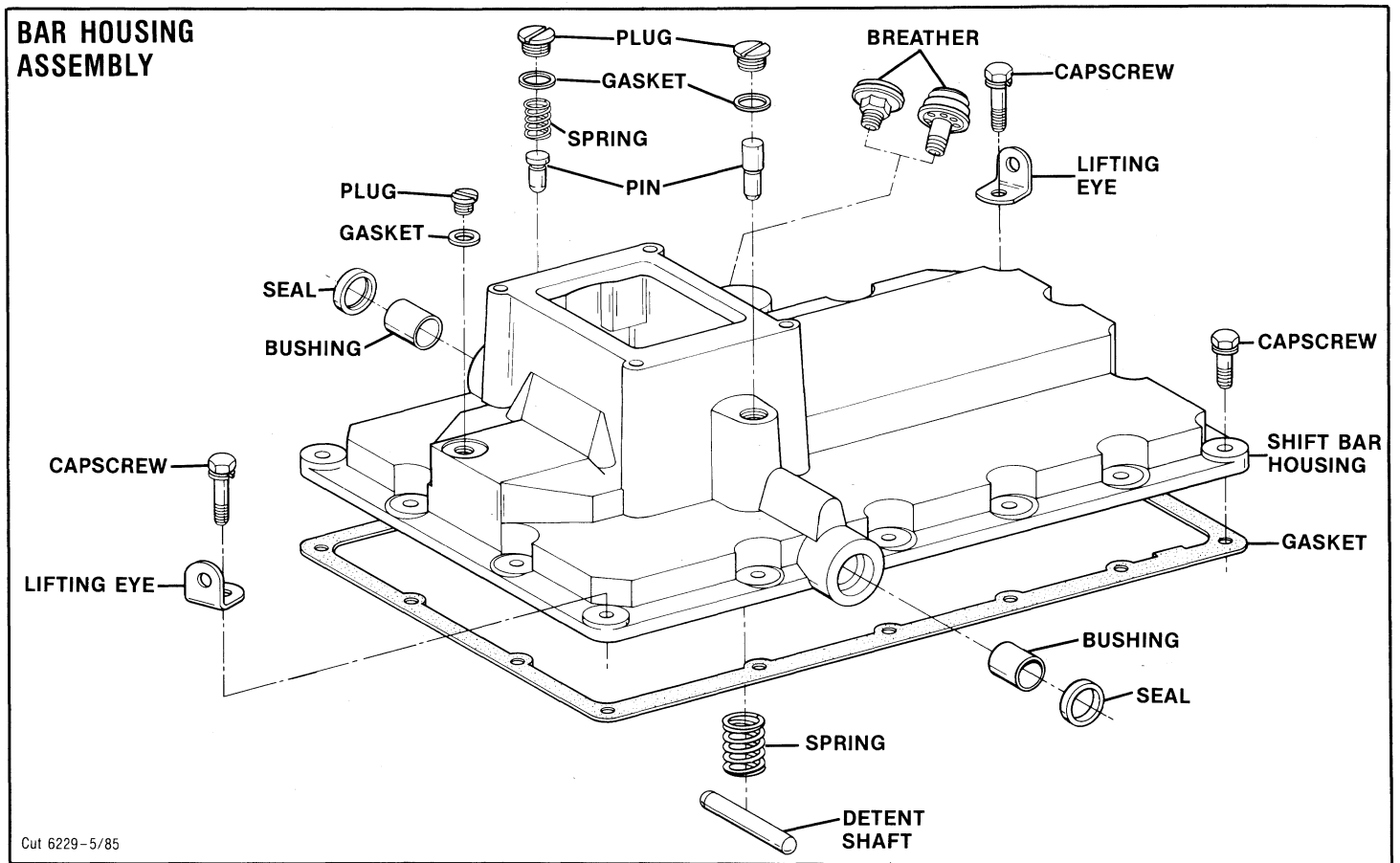

# DISASSEMBLY AND REASSEMBLY SHIFTING CONTROLS

## SHIFT BAR HOUSING ASSEMBLY (con't.)

### YOKES & BARS

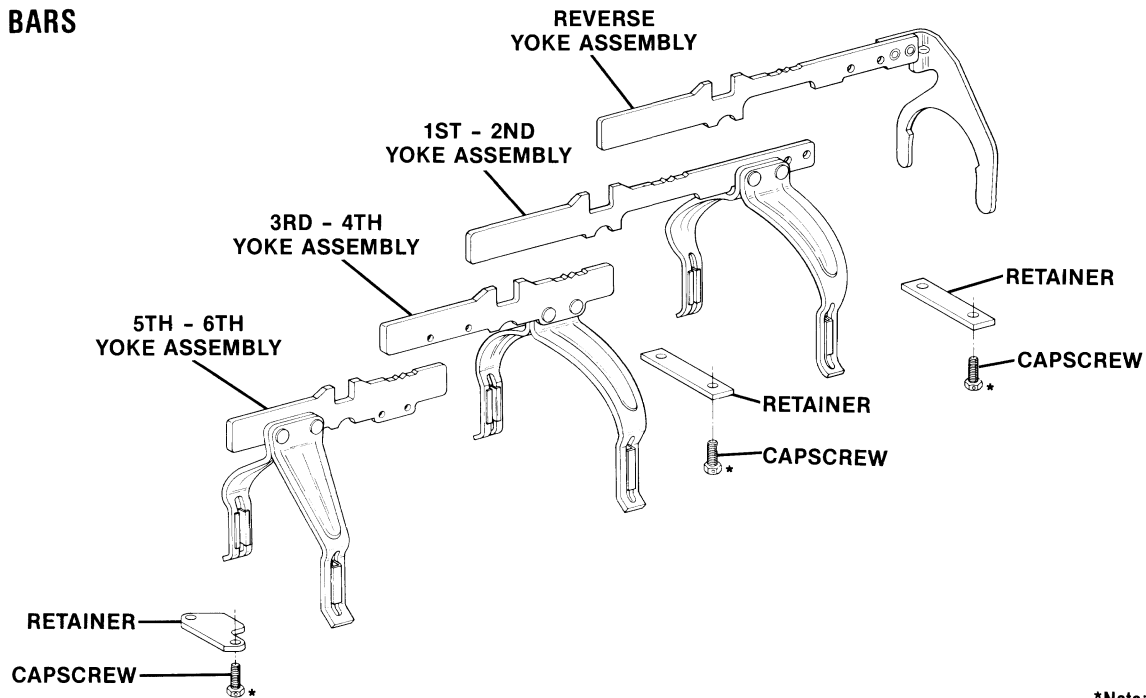

Cut 6230-5/85

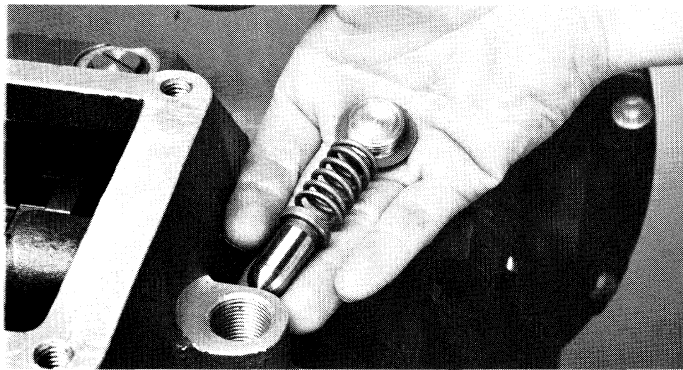

20-01

1. Remove plug, spring, and pin from housing.

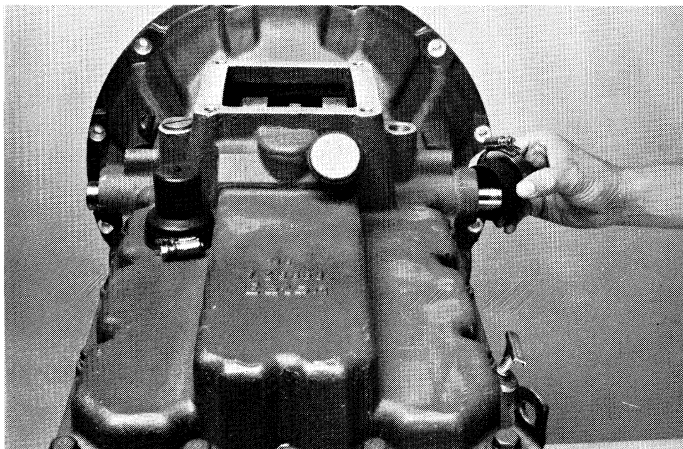

20-02

2. Loosen clamps and remove rubber boots from shift shafts.

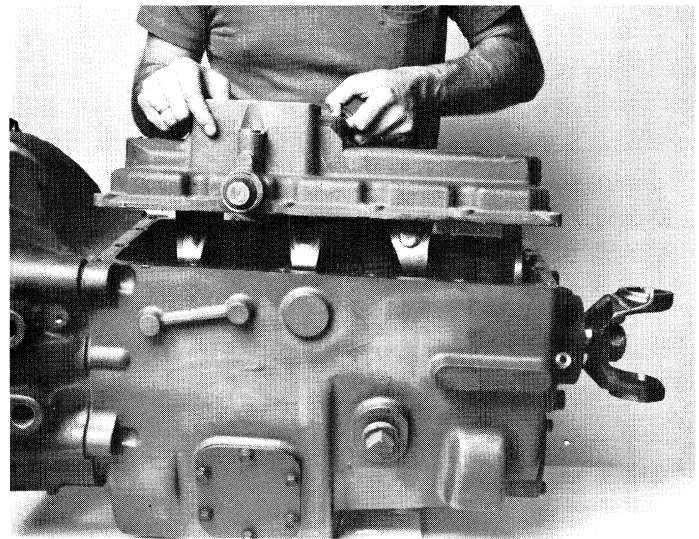

20-03

3. Turn out capscrews and lift shift bar housing from case.

# DISASSEMBLY AND REASSEMBLY SHIFTING CONTROLS

## SHIFT BAR HOUSING ASSEMBLY (con't.)

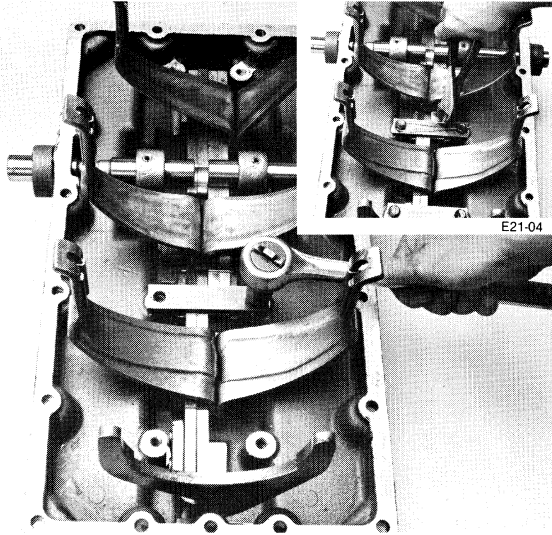

21-04

4. Lay shift bar housing on workbench as shown. Cut lockwire from three shift rail retainers (inset), remove capscrews and retainers.

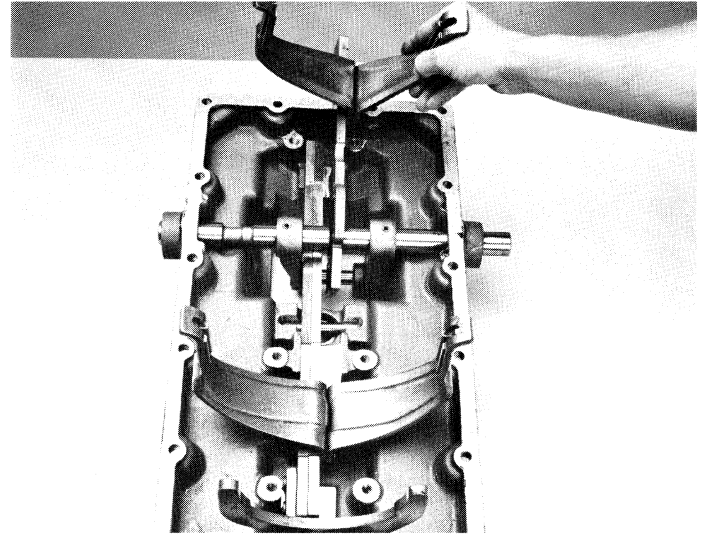

21-06

6. Center opening between shift shafts over fifth-sixth rail and remove yoke assembly.

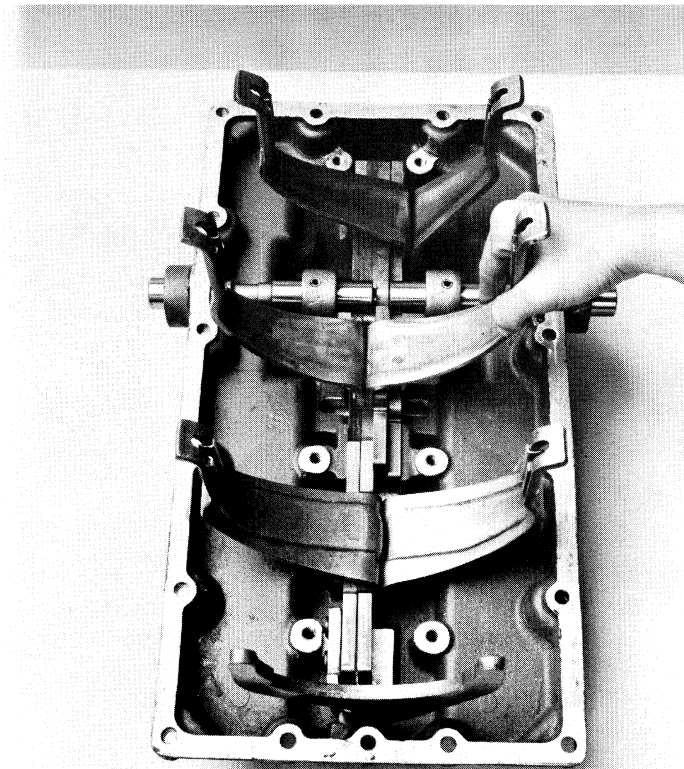

21-05

5. Center opening between shift shafts over third-fourth rail and remove yoke assembly.

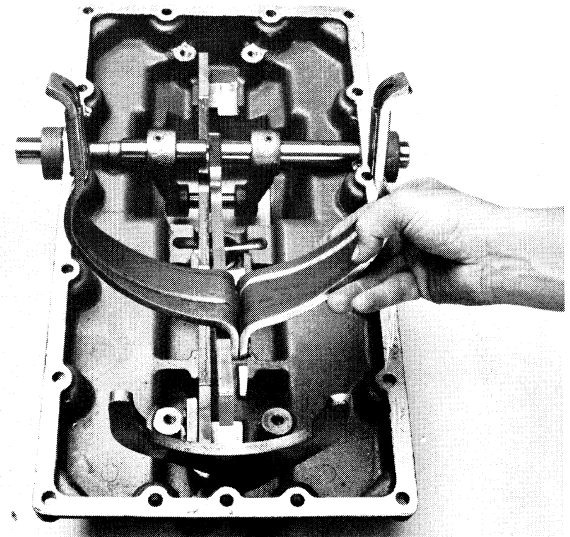

21-07

7. Center opening between shift shafts over first-second rail and remove yoke assembly.

# DISASSEMBLY AND REASSEMBLY SHIFTING CONTROLS

## SHIFT BAR HOUSING ASSEMBLY (con't.)

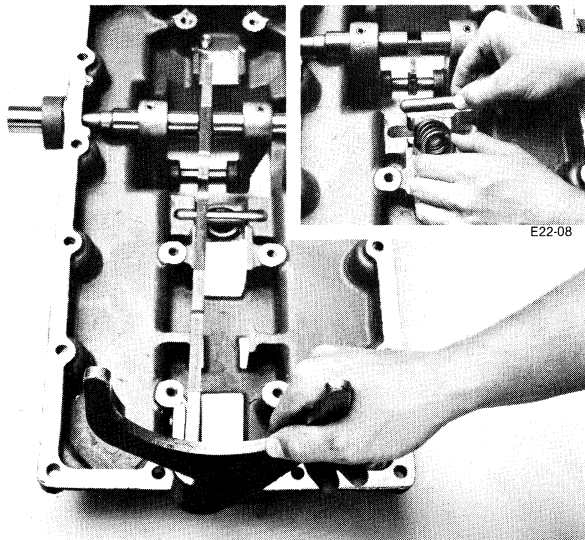

8. Remove reverse yoke assembly by sliding to opening between left and right shift shafts. Remove detent shaft and spring from housing (inset).

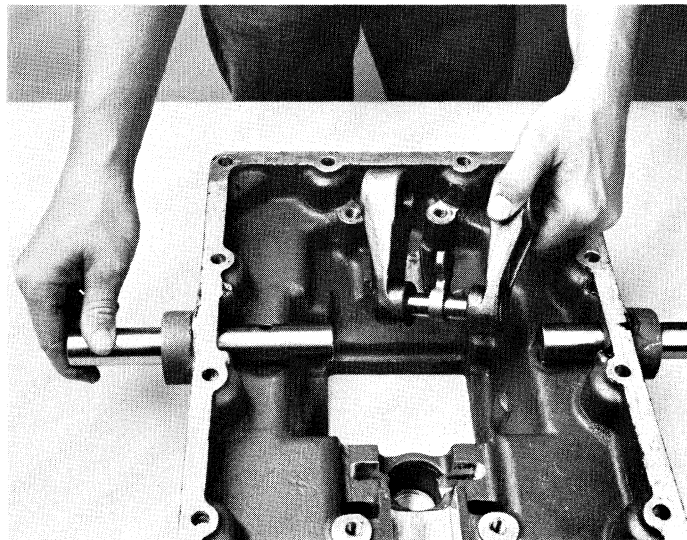

10. Slide shift shafts toward outside of housing, and remove finger assembly.

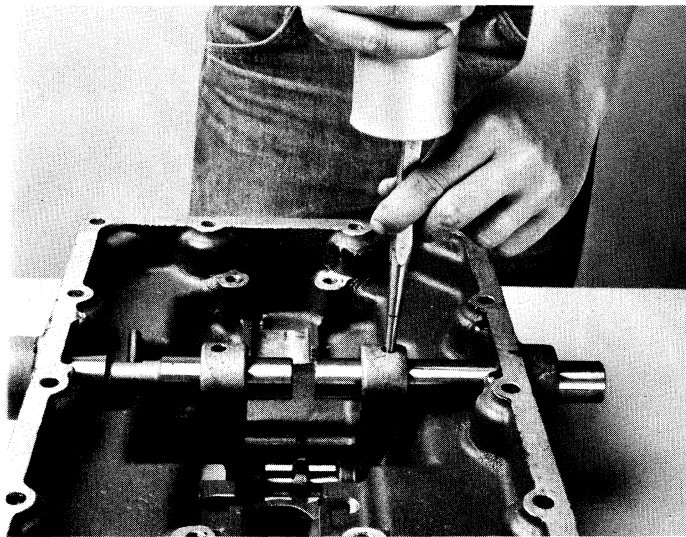

9. Using a punch, drive both roll pins from finger assembly.

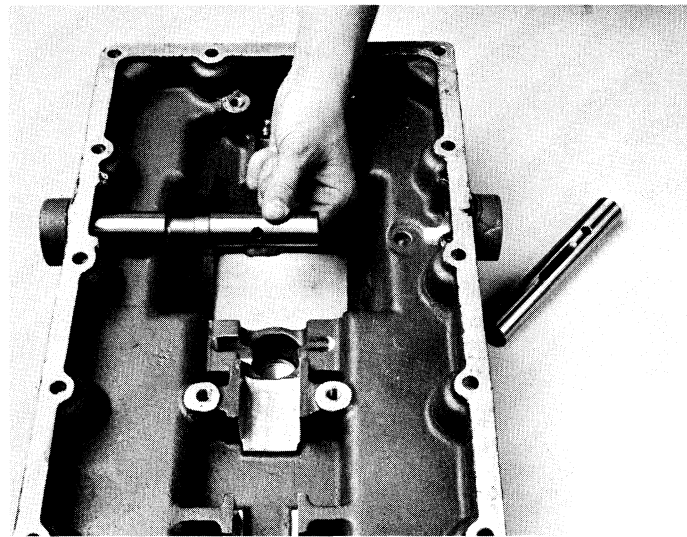

11. Remove shift shafts from housing. **Note:** To prevent damaging the seal, remove step shaft toward inside of housing. If necessary, remove seals and bushings from bores of housing.



# DISASSEMBLY AND REASSEMBLY SHIFTING CONTROLS

## SHIFT BAR HOUSING ASSEMBLY (con't.)

### B. Reassembly of Shift Bar Housing

Note: If previously removed, install new bushings and seals in bores of housing.

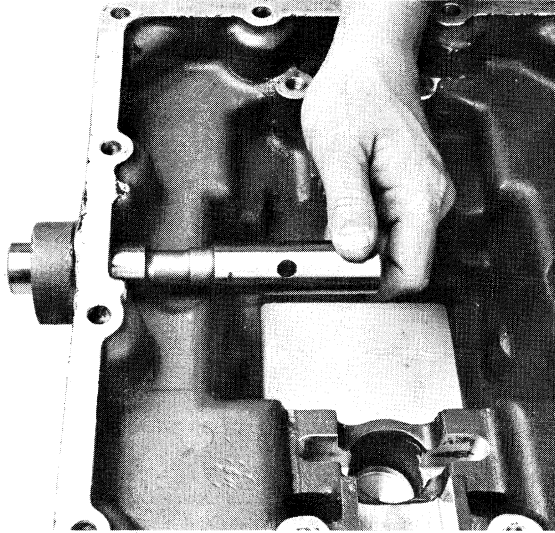

1. Install stepped shaft in bore of housing as shown.

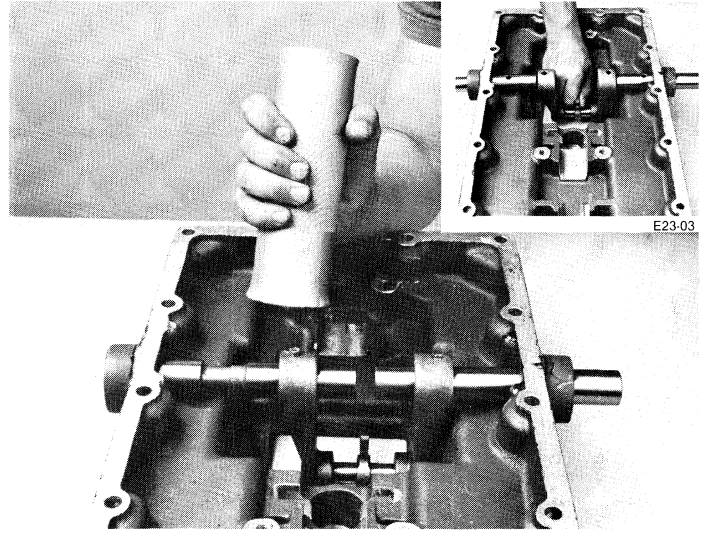

3. Position finger assembly between shafts (inset). Move shafts inward aligning bores of shafts with shift finger bore. Drive roll pins in place.

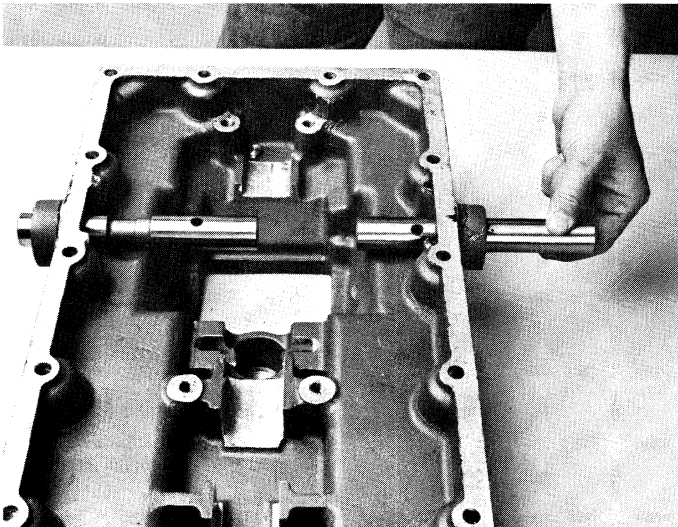

2. Install remaining shaft in bore, slot in shaft facing down.

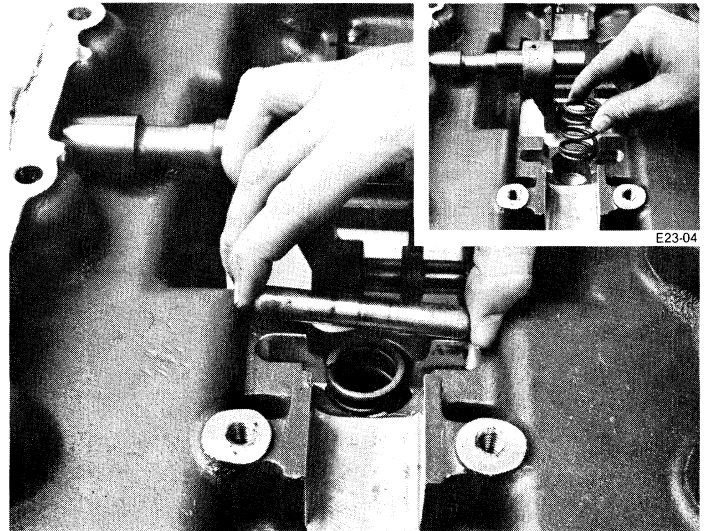

4. Install spring (inset) and detent shaft in housing.

# DISASSEMBLY AND REASSEMBLY SHIFTING CONTROLS

## SHIFT BAR HOUSING ASSEMBLY (con't.)

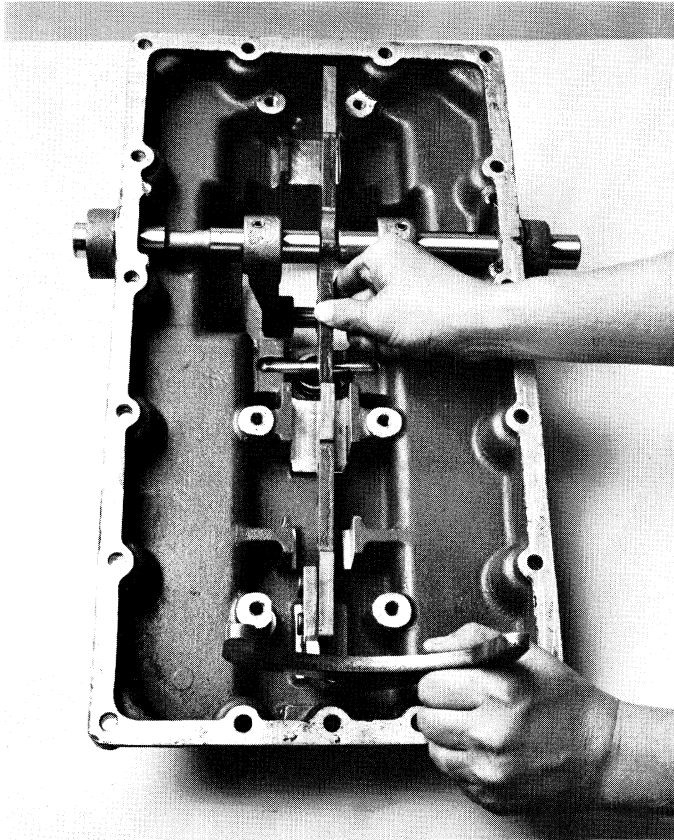

5. Position reverse yoke assembly in housing as shown.

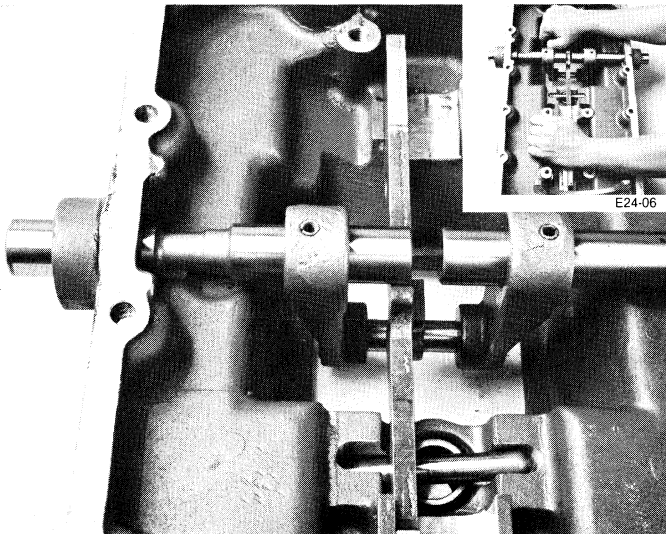

6. Push down on rail of yoke assembly to compress detent spring (inset), and move shift finger assembly over rail.

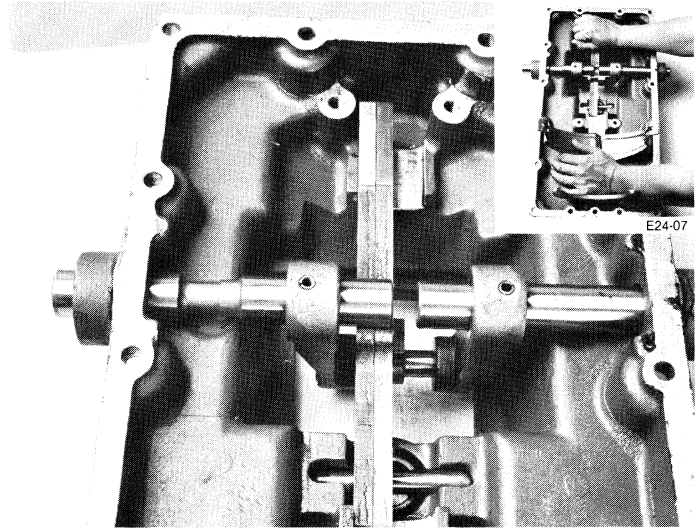

7. Position first-second yoke assembly in housing and push down on rail of yoke assembly to compress detent spring (inset). Move shift finger assembly over rail as shown.

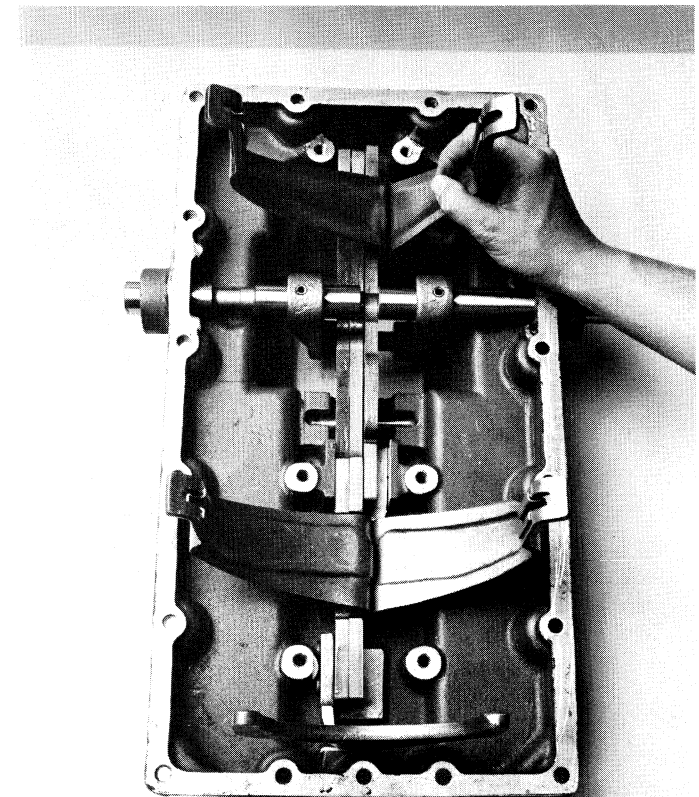

8. Position fifth-sixth yoke assembly in housing as shown.

# DISASSEMBLY AND REASSEMBLY SHIFTING CONTROLS

## SHIFT BAR HOUSING ASSEMBLY (con't.)

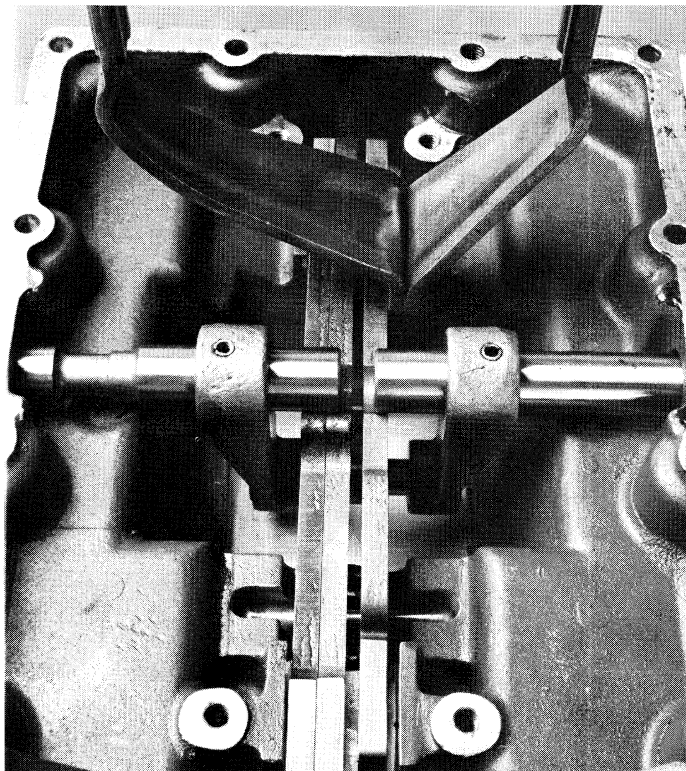

25-09

9. Push down on rail of yoke assembly to compress detent spring and move shift finger assembly over rail.

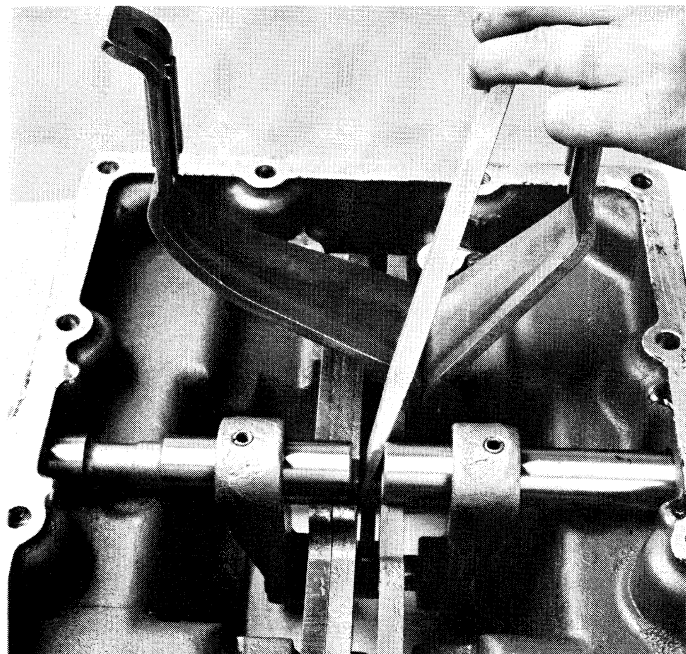

25-10

10. Spread fifth-sixth rail and first-second rail apart using a screwdriver to align opening between shift shafts with opening between rails.

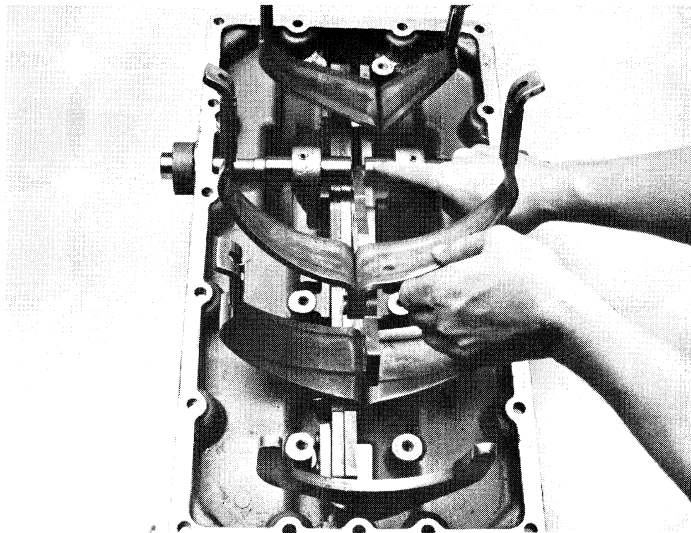

25-11

11. Install third-fourth yoke assembly by sliding between shift shafts and rails as shown.

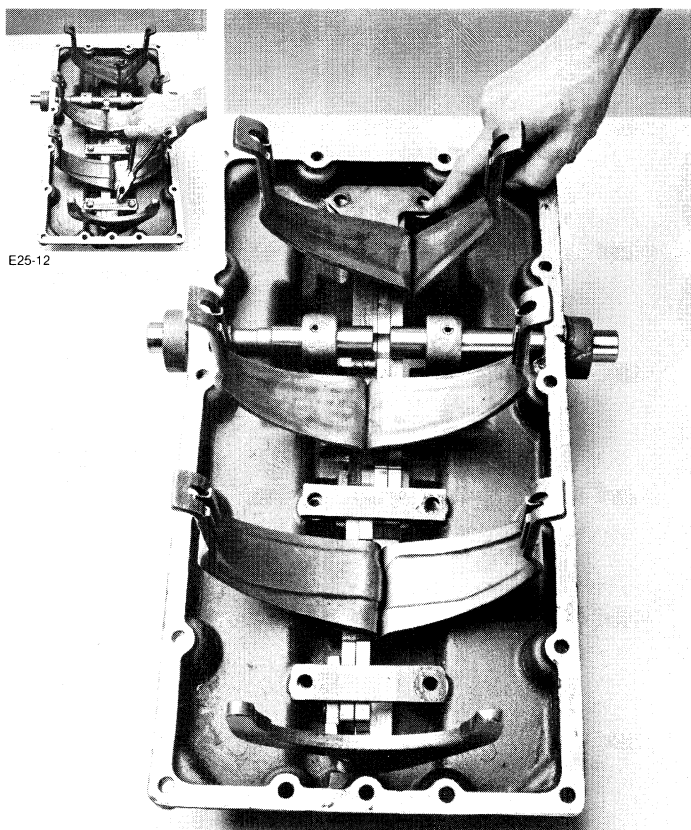

E25-12

25-12

12. Position three retainers as shown. Install cap screws and lockwire securely (inset).

Procedure for installation of shifting controls is on page 55.



# REMOVAL - REAR YOKE AND CLUTCH HOUSING

## A. Removal of Rear Yoke

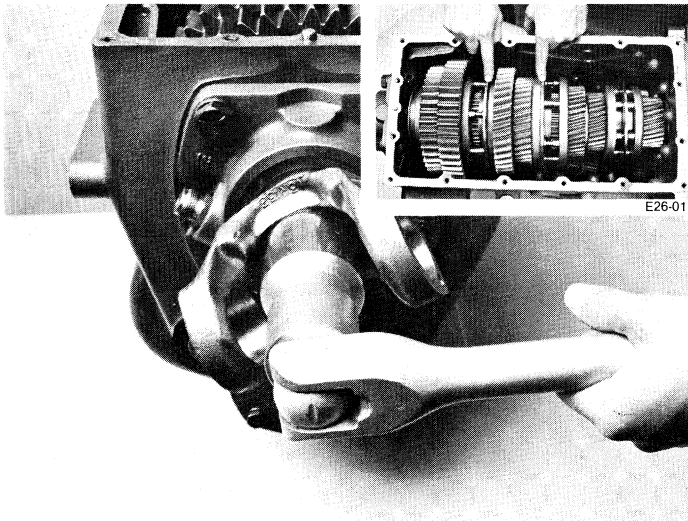
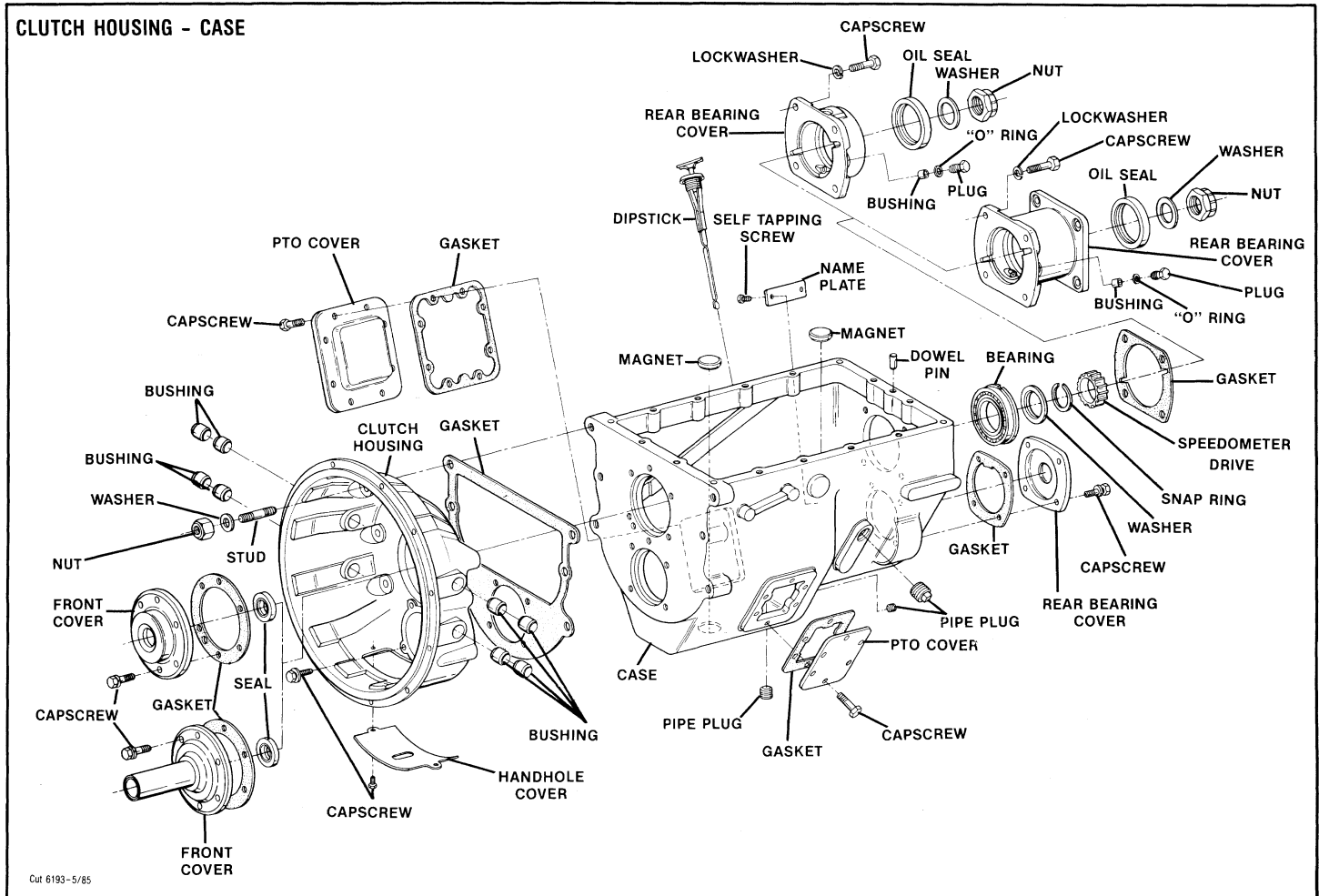

26-01

1. Lock the transmission by engaging two main shaft gears (inset). Use a large breaker bar to turn the nut from output shaft.

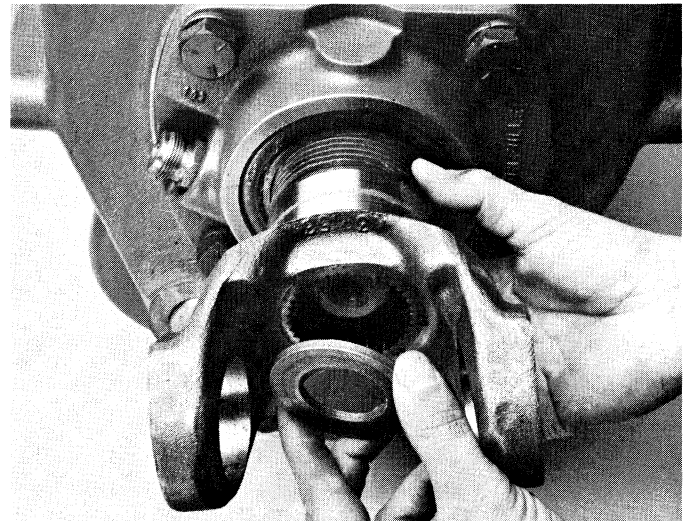

26-02

2. Remove washer and yoke from output shaft.

# REMOVAL - REAR YOKE AND CLUTCH HOUSING

---

## B. Removal of Clutch Housing

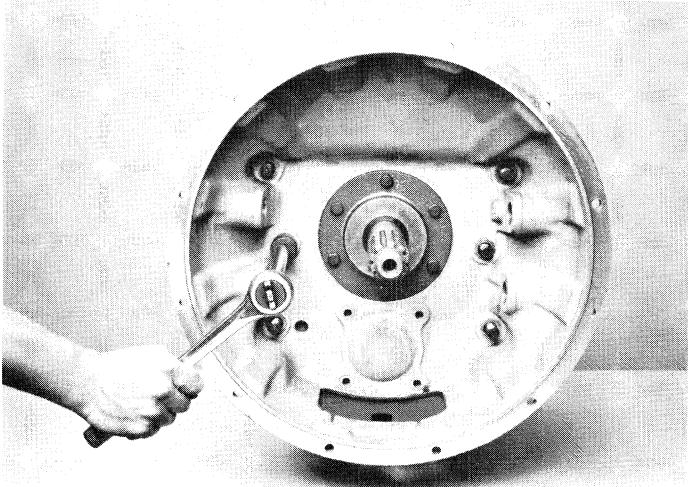

27-01

1. Remove four cap screws and six nuts and washers from studs.

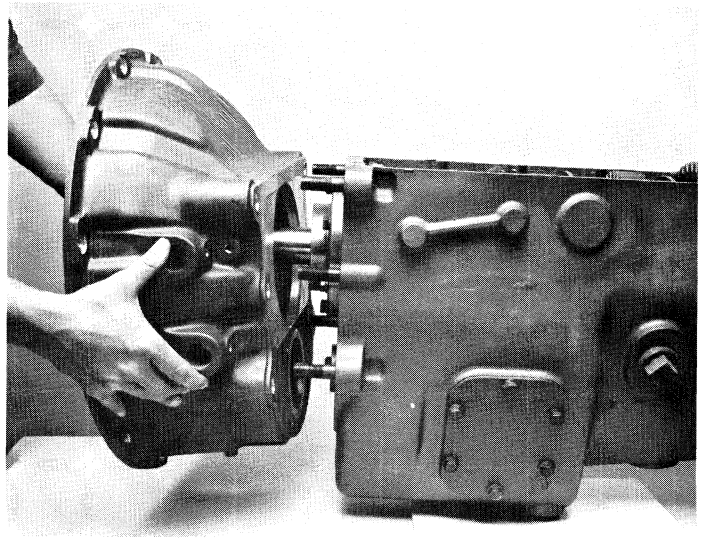

27-02

2. Jar clutch housing with rubber mallet and pull from transmission case.

# DISASSEMBLY OF TRANSMISSION

## A. Removal & Disassembly of Input Shaft Assembly

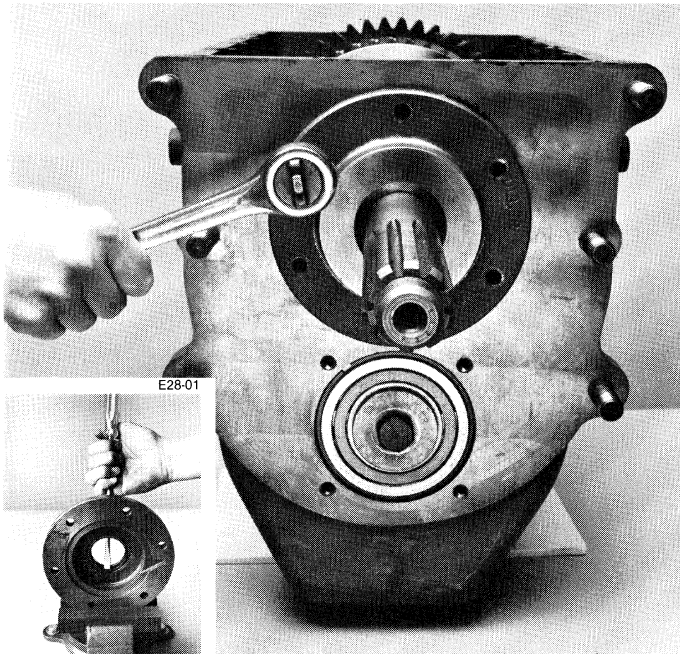

1. Turn out six cap screws and remove front bearing cover. If necessary, remove oil seal from cover (inset).

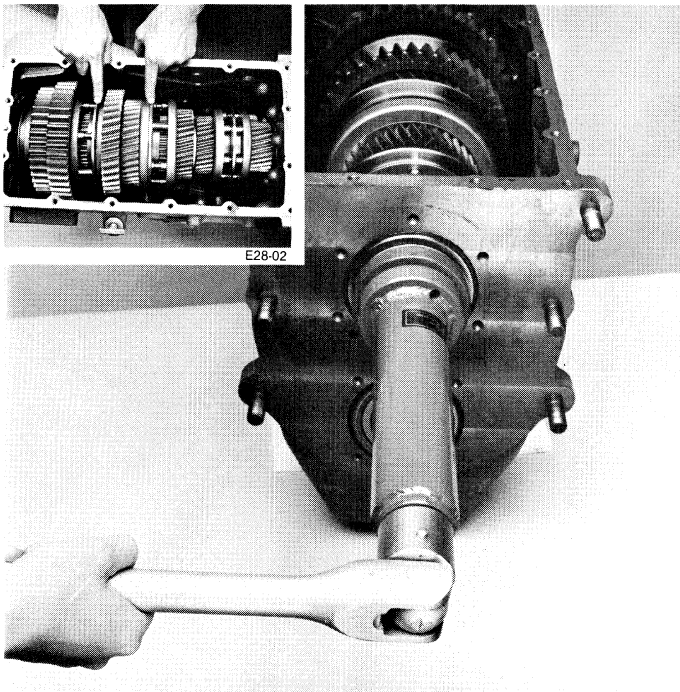

2. Lock transmission by engaging it into two gears (inset). Remove nut from input shaft.  
**Note:** Nut has left hand threads, remove by turning clockwise.

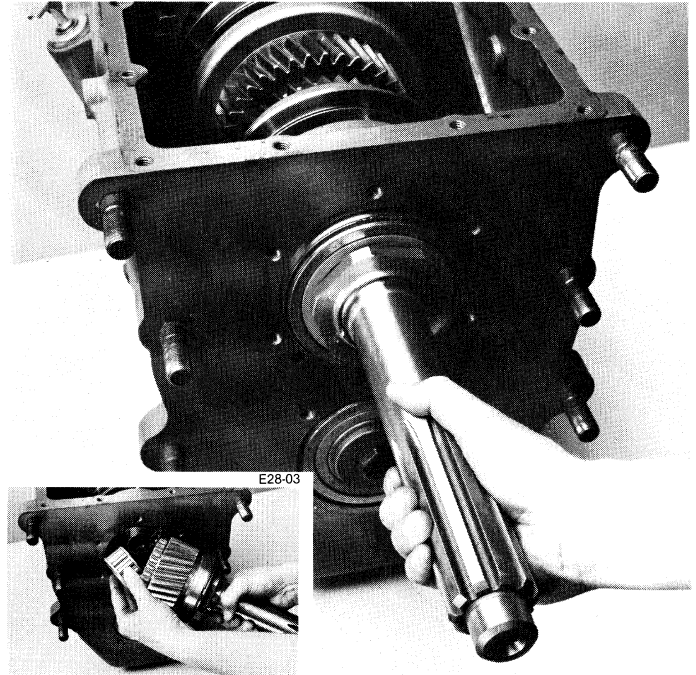

3. Remove input shaft drive gear from case bore. Use caution as spigot bearing is free to fall from shaft when removed (inset).

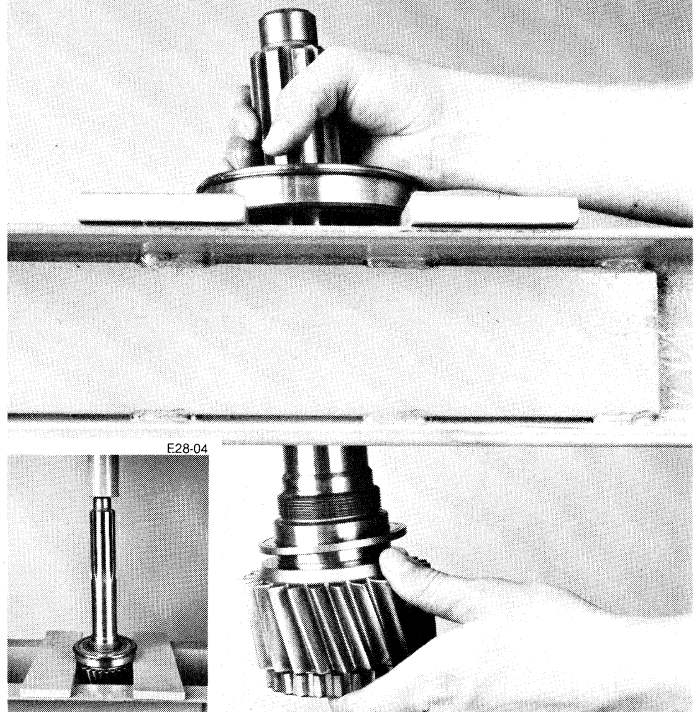

4. Block under bearing (inset). Press input shaft drive gear through bearing.

# DISASSEMBLY OF TRANSMISSION

## B. Removal and Disassembly of Main Shaft

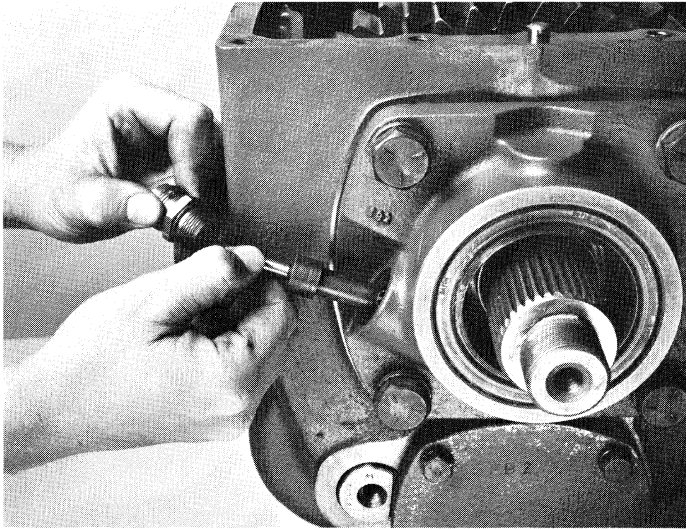

29-01

1. Turn out speedometer sleeve and remove speedometer driven gear.

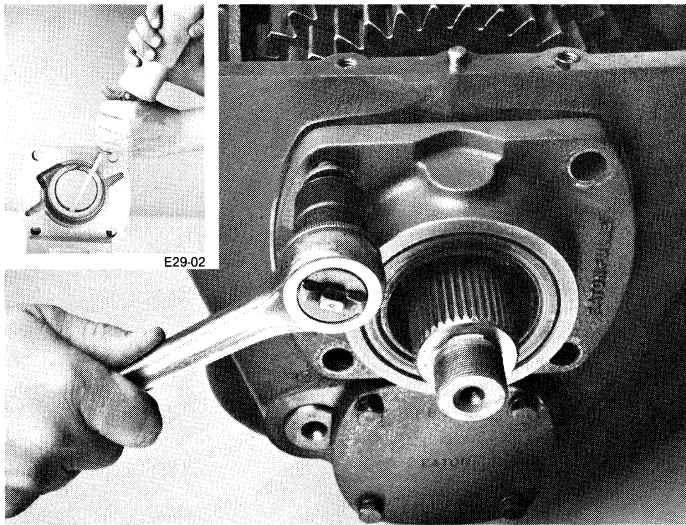

29-02

2. Turn out four cap screws and remove rear bearing cover and speedometer drive gear. If necessary, remove oil seal from cover (inset).

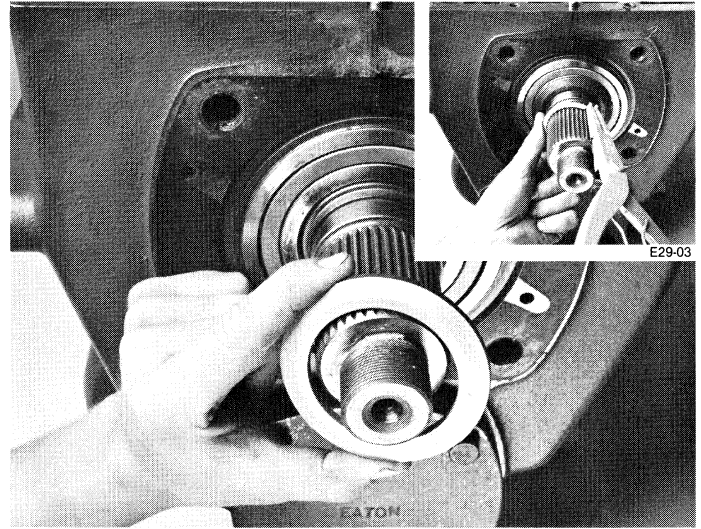

E29-03

29-03

3. Remove snap ring from output shaft (inset). Remove washer.

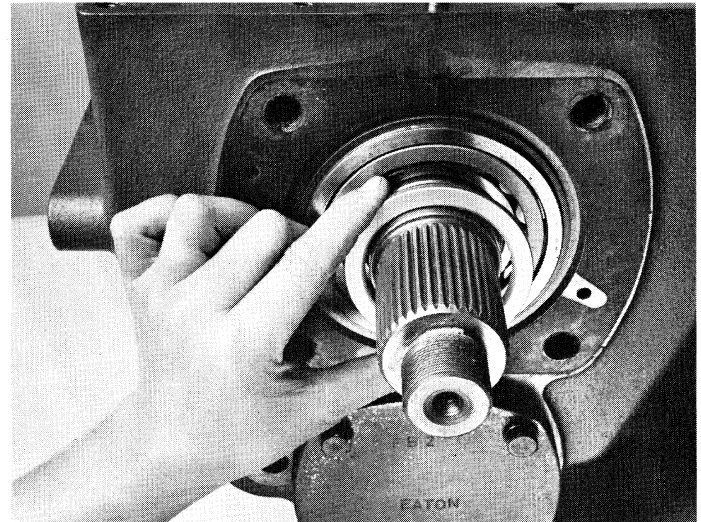

29-04

4. Remove spacer from bearing.



# DISASSEMBLY OF TRANSMISSION

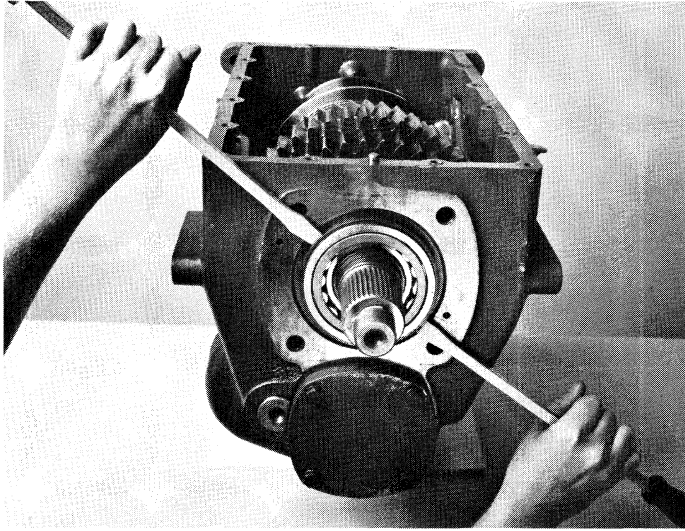

30-05

5. Tap mainshaft rearward to expose rear bearing snap ring. Use screwdrivers to remove bearing from bore.

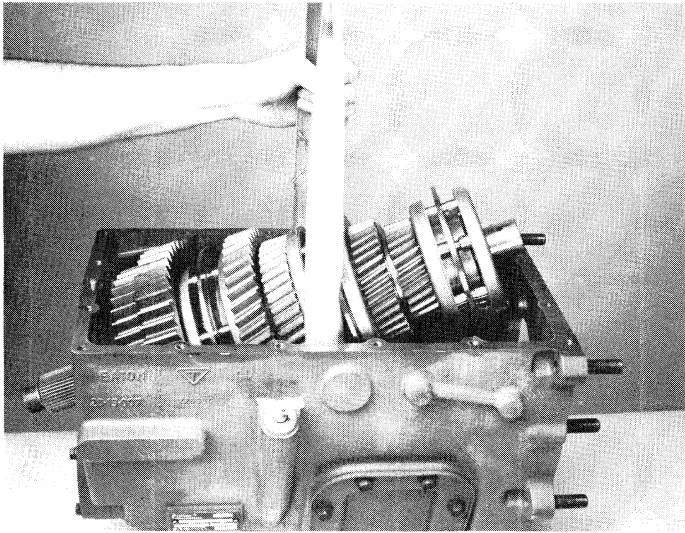

30-06

6. Wrap sling around mainshaft as shown. Use hoist to remove mainshaft assembly from case. **NOTE:** Use caution as assembly weighs approximately 130 lbs.

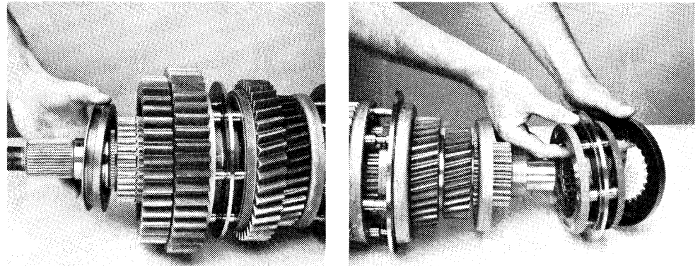

L30-07

R30-07

7. Remove reverse clutch hub from rear of main shaft (left). Remove 5th-6th synchronizer and 6th gear cup from front of main shaft (right).

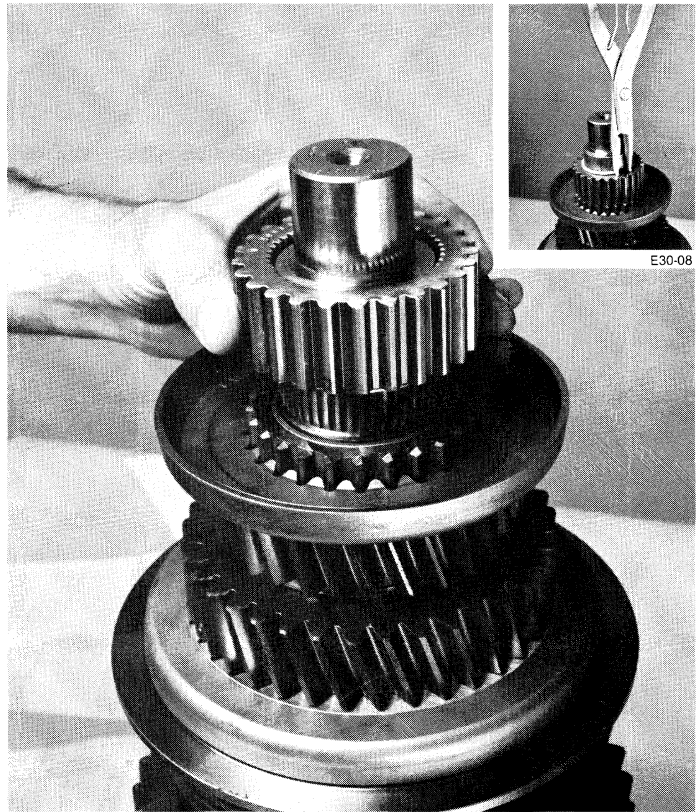

E30-08

30-08

8. Install main shaft assembly in vise equipped with soft jaws or wood, front of shaft facing up. Remove snap ring from front of 5th-6th clutch hub (inset). Remove 5th-6th clutch hub from main shaft.

# DISASSEMBLY OF TRANSMISSION

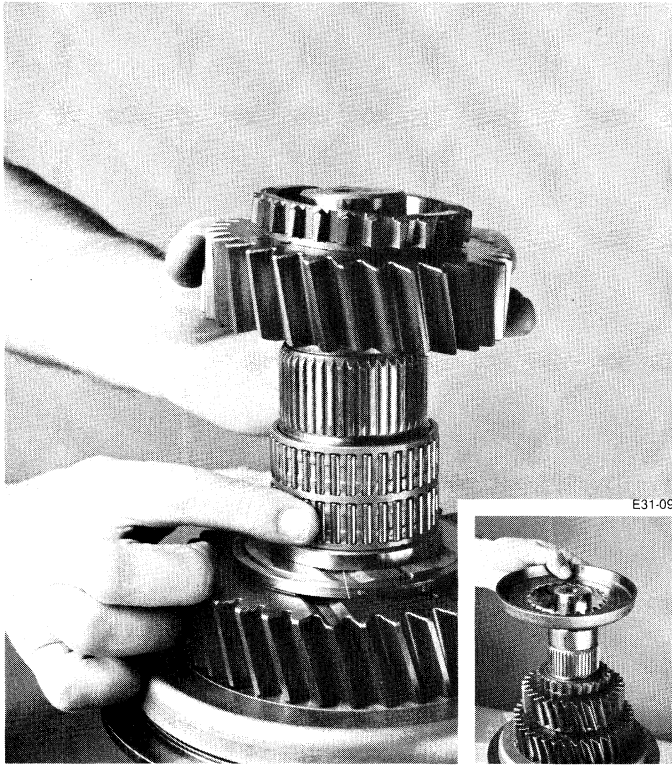

9. Remove synchronizer cup (inset) 5th gear and bearing from main shaft.

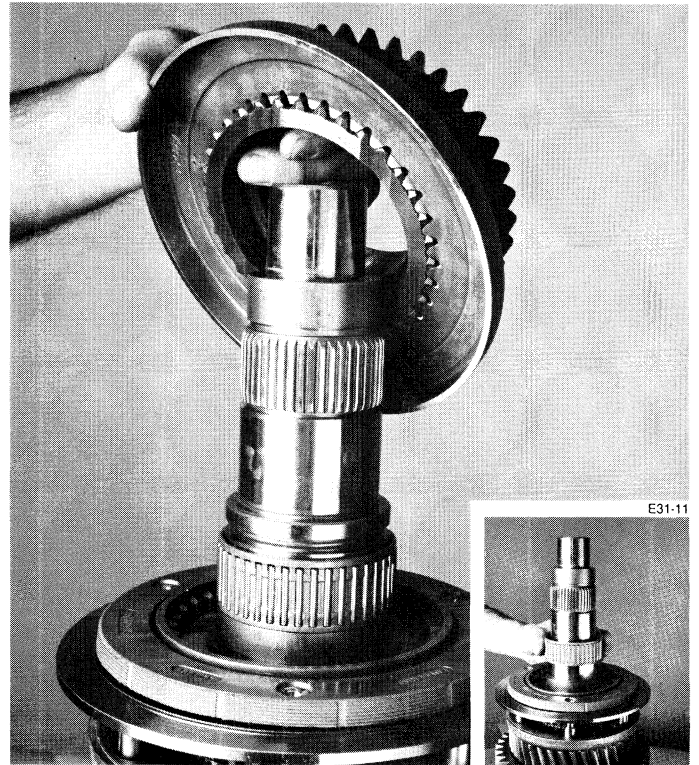

11. Remove 4th gear, synchronizer cup and bearing (inset).

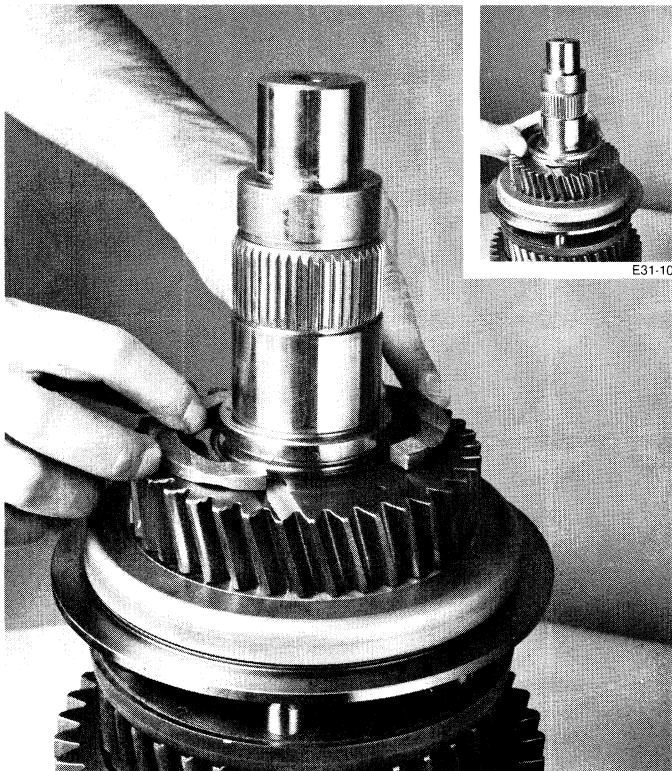

10. Remove retaining ring (inset) and split washers.

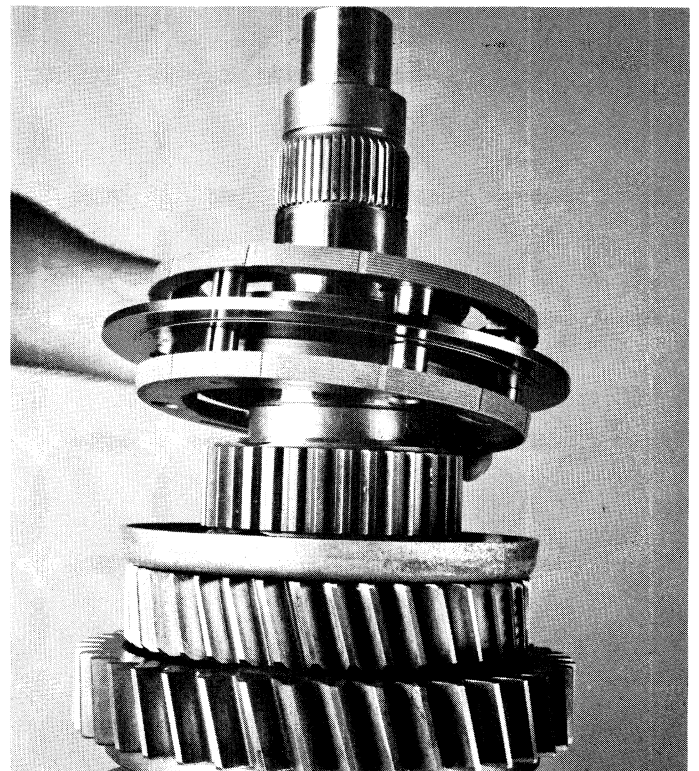

12. Remove 3rd-4th speed synchronizer.



# DISASSEMBLY OF TRANSMISSION



13. Remove snap ring from front of 3rd-4th clutch hub (inset). Remove clutch hub from main shaft.

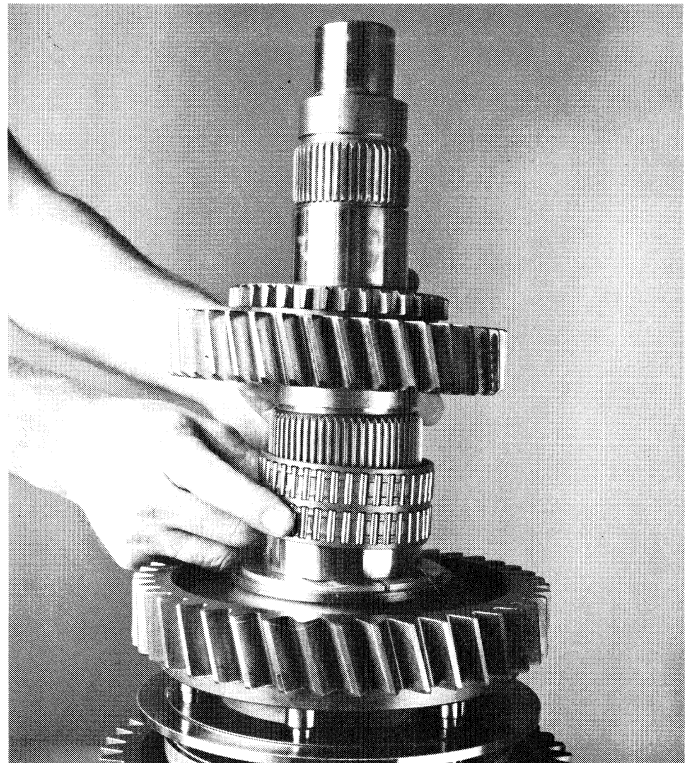

15. Remove 3rd gear and bearing.

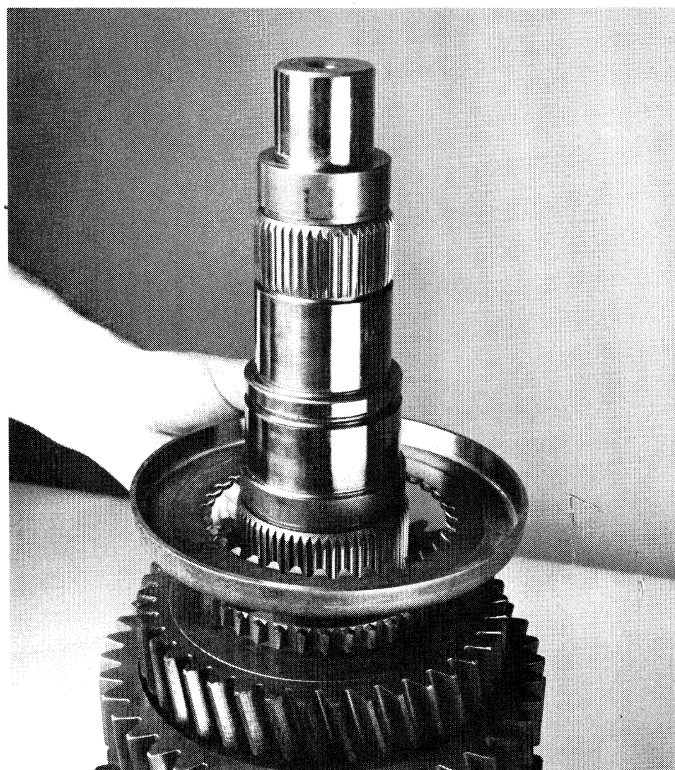

14. Remove synchronizer cup from 3rd gear.



16. Remove retainer (inset) and split washers.

# DISASSEMBLY OF TRANSMISSION

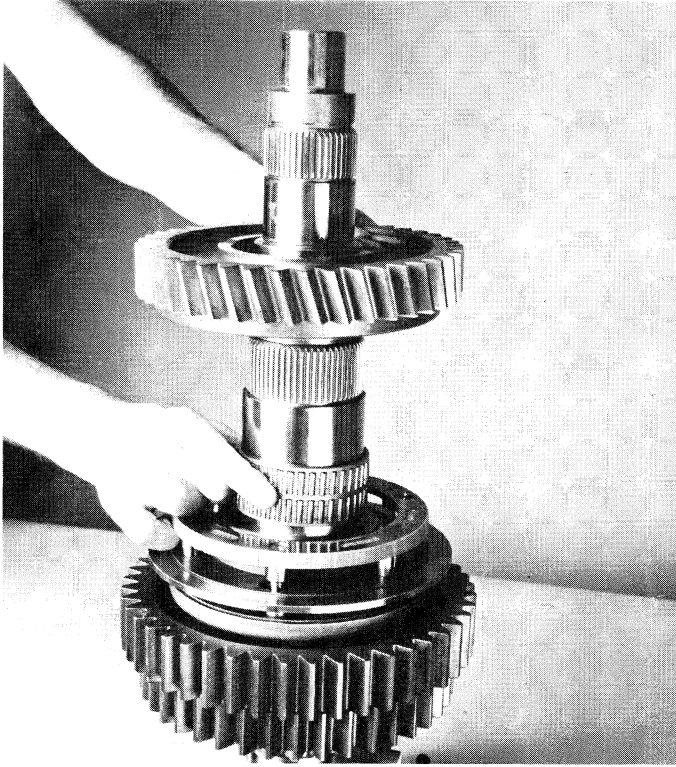

33-17

17. Remove 2nd gear and bearing.

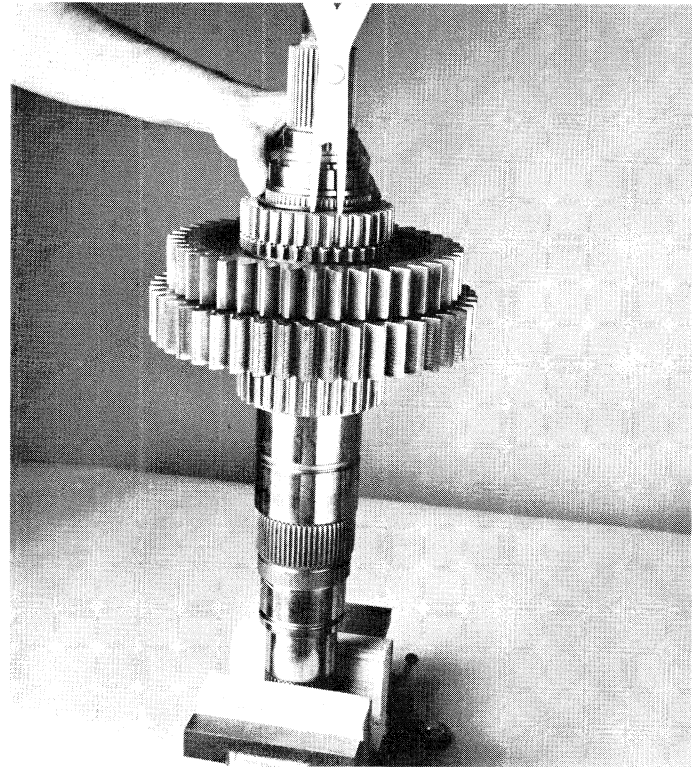

33-19

19. Reposition main shaft in vise, rear of shaft facing up. Remove reverse hub snap ring.

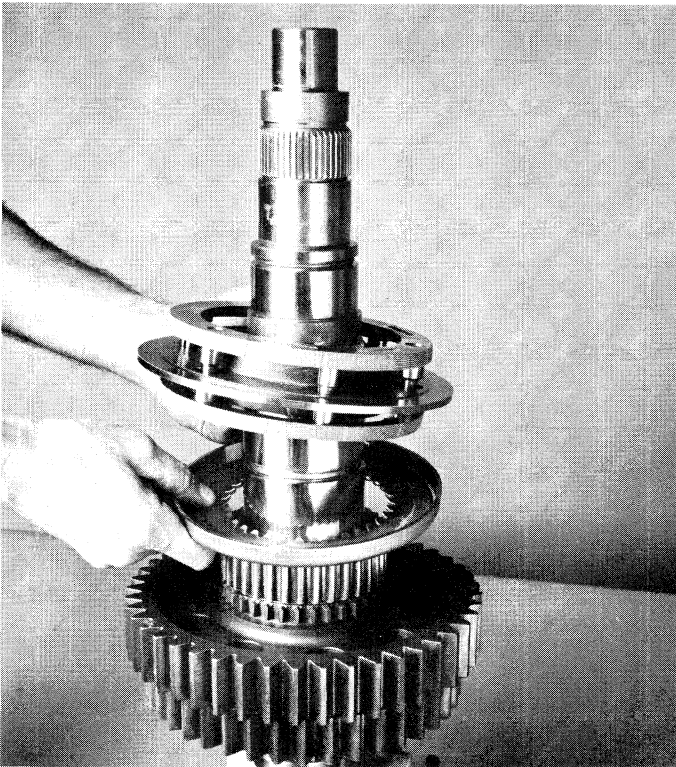

33-18

18. Remove 1st-2nd synchronizer assembly and 1st gear cup.

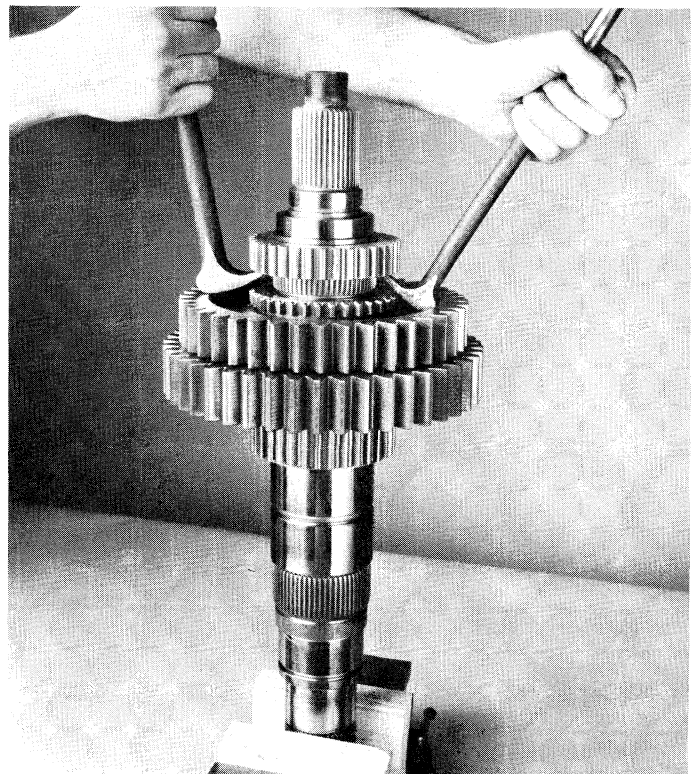

33-20

20. Using crow's-foot or screwdrivers, remove reverse hub and rear bearing race.



# DISASSEMBLY OF TRANSMISSION

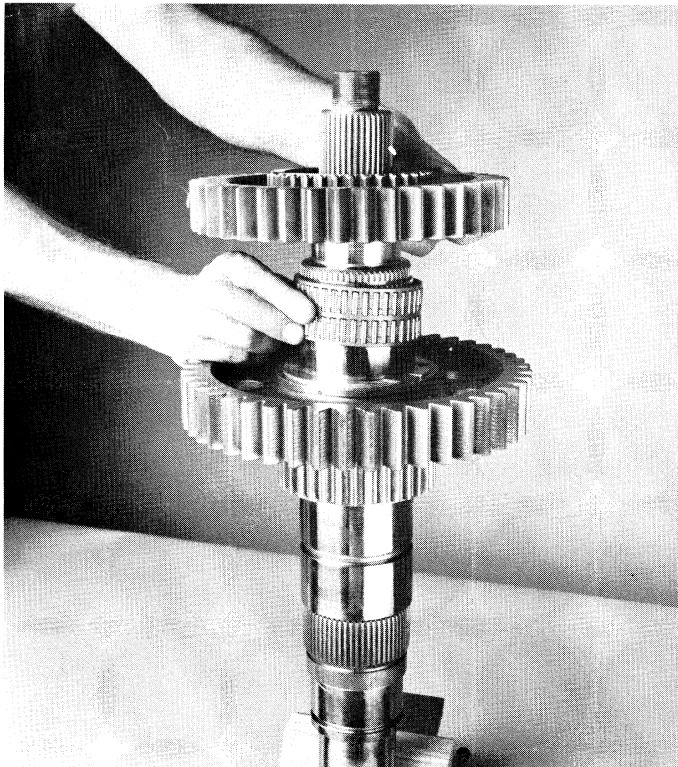

34-21

21. Remove reverse gear and bearing.

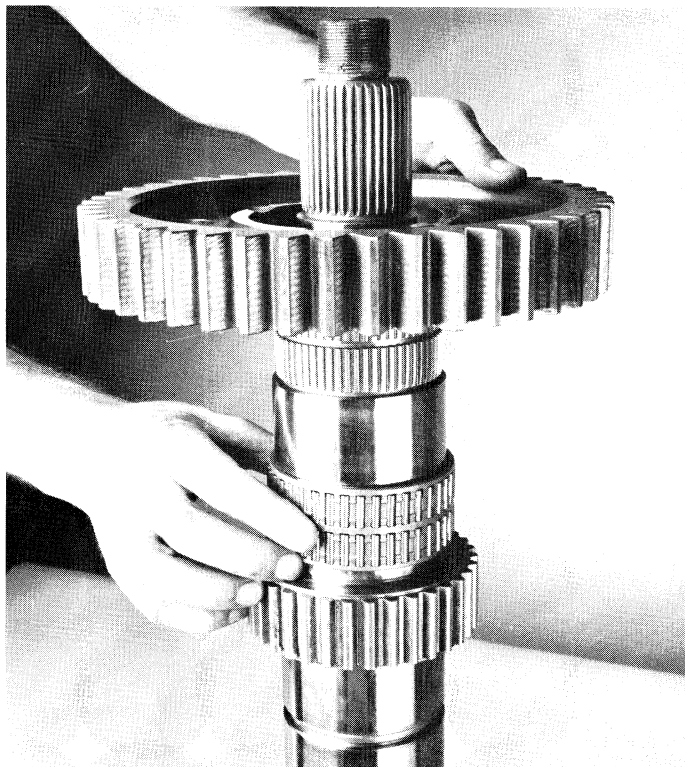

34-23

23. Remove 1st gear and bearing. Remove main shaft from vise.

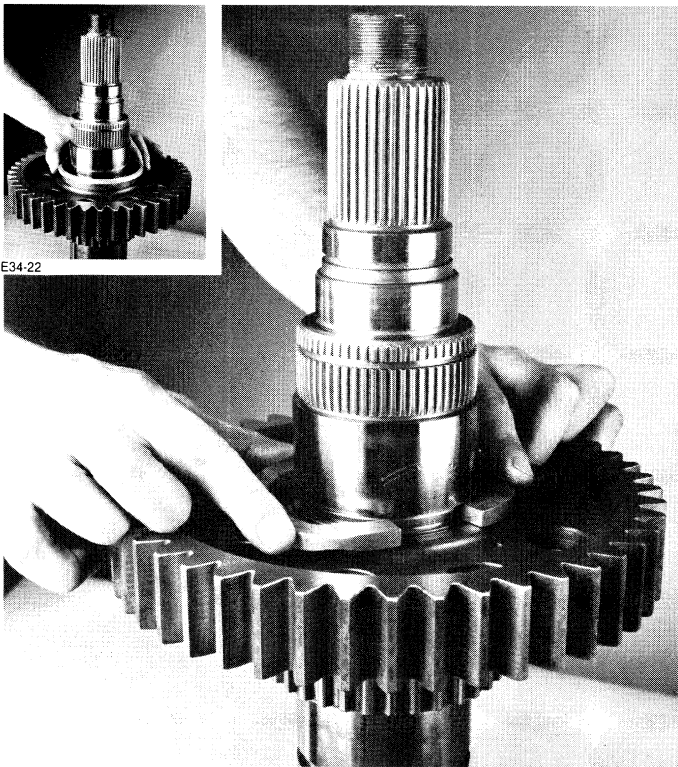

34-22

22. Remove retaining ring (inset) and split washers.

# DISASSEMBLY OF TRANSMISSION

## C. Removal and Disassembly of Countershaft Assembly

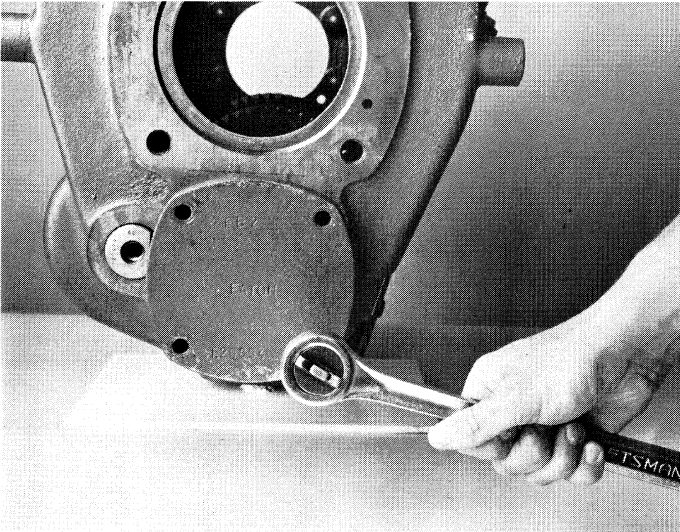

35-01

1. Remove rear countershaft bearing cover and cap screws.

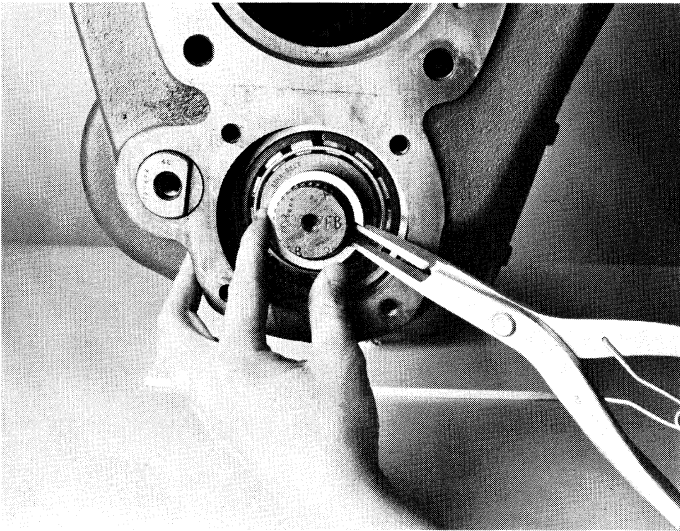

35-02

2. Remove snap ring from groove of countershaft.

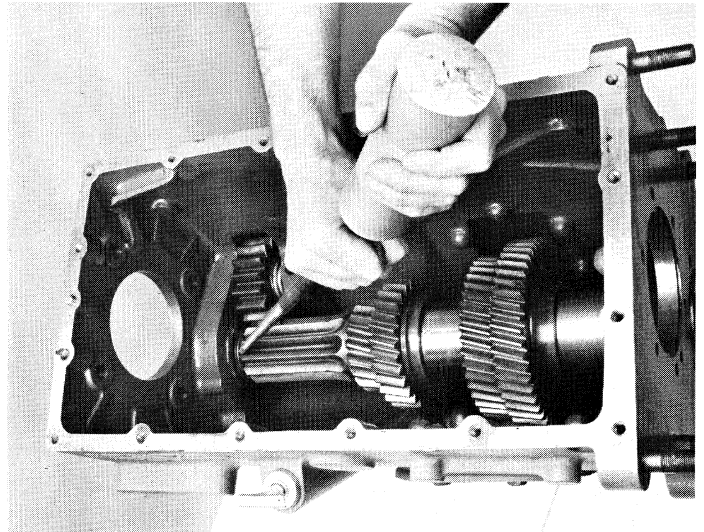

35-03

3. From inside the case, drive countershaft rear bearing from case bore using maul and punch. **(Note: Bearing will be damaged during removal. Replacement is highly recommended.)**

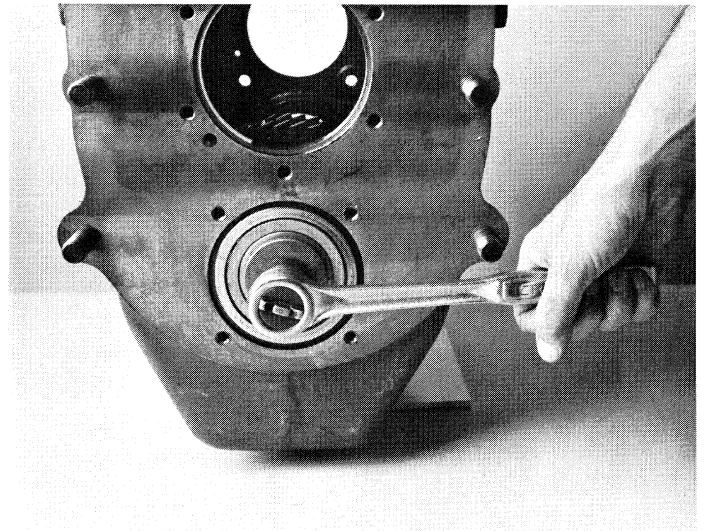

35-04

4. Turn out cap screw and remove front bearing retainer plate.

# DISASSEMBLY OF TRANSMISSION

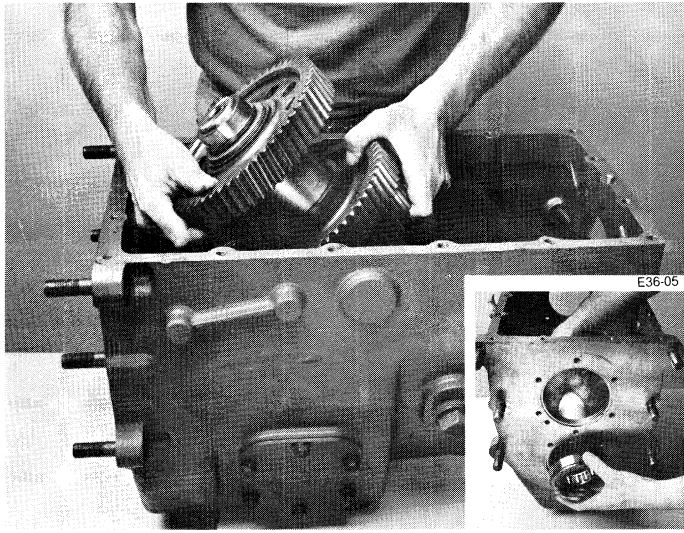

5. Move countershaft assembly to the rear and lift it from case. With a soft bar, remove front countershaft bearing from bore (inset).

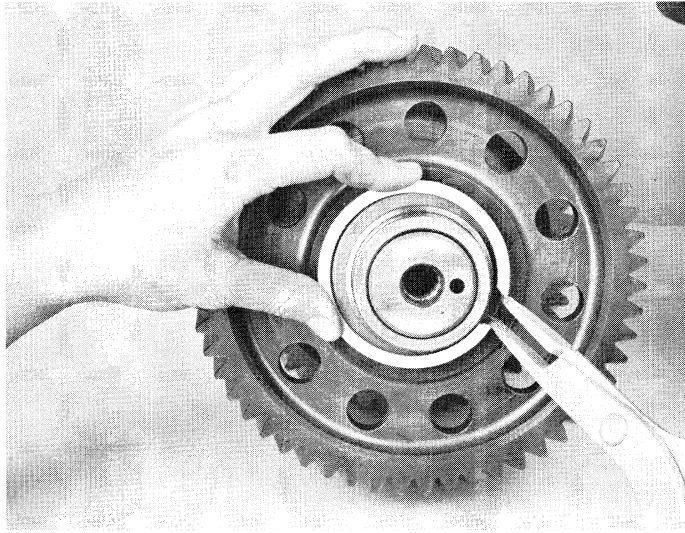

6. Remove drive gear retaining snap ring from front of shaft.

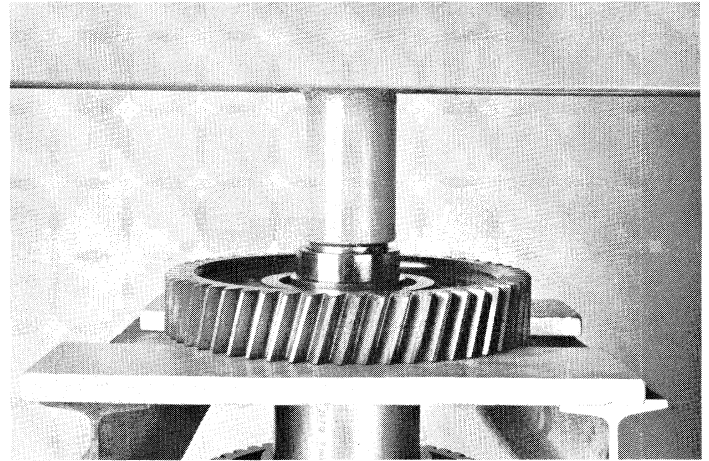

7. Use the rear face of the drive gear as a base, then press it from the countershaft as shown.

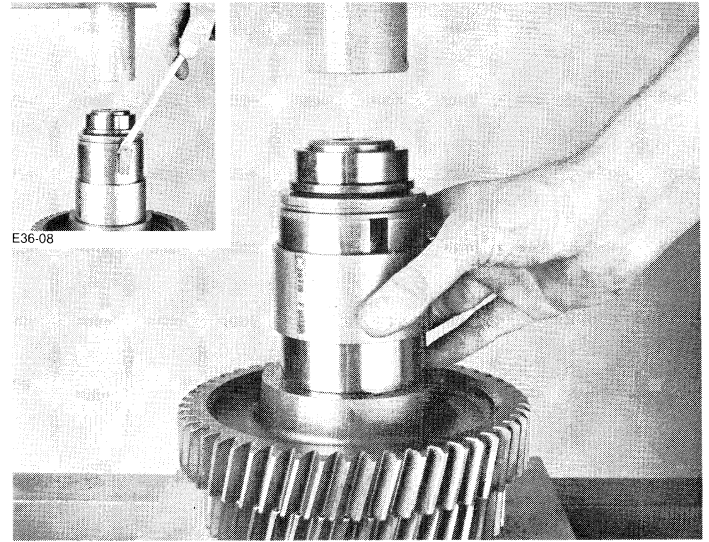

8. Remove drive gear key from shaft (inset), then remove spacer.



# DISASSEMBLY OF TRANSMISSION

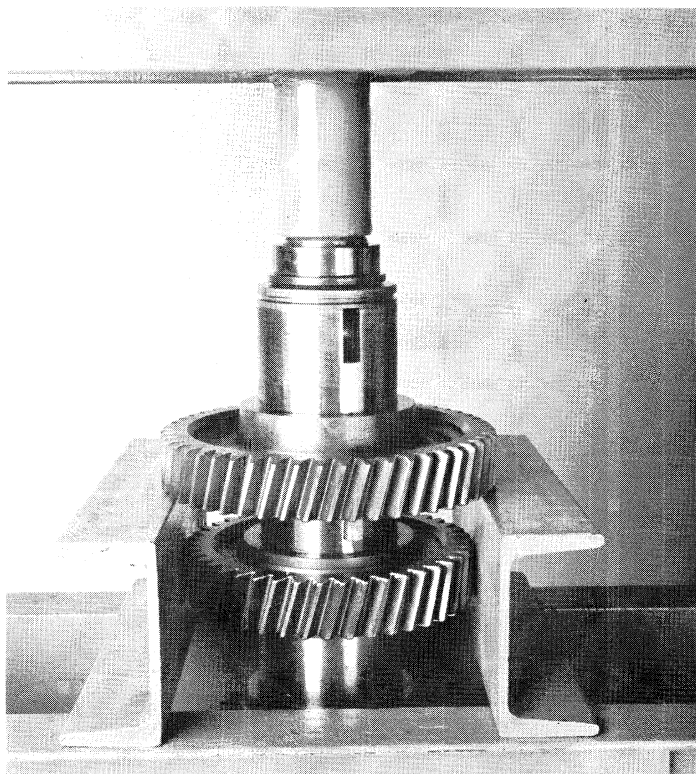

37-09

9. Using the rear face of 5th speed gear as a base, press it from the countershaft.

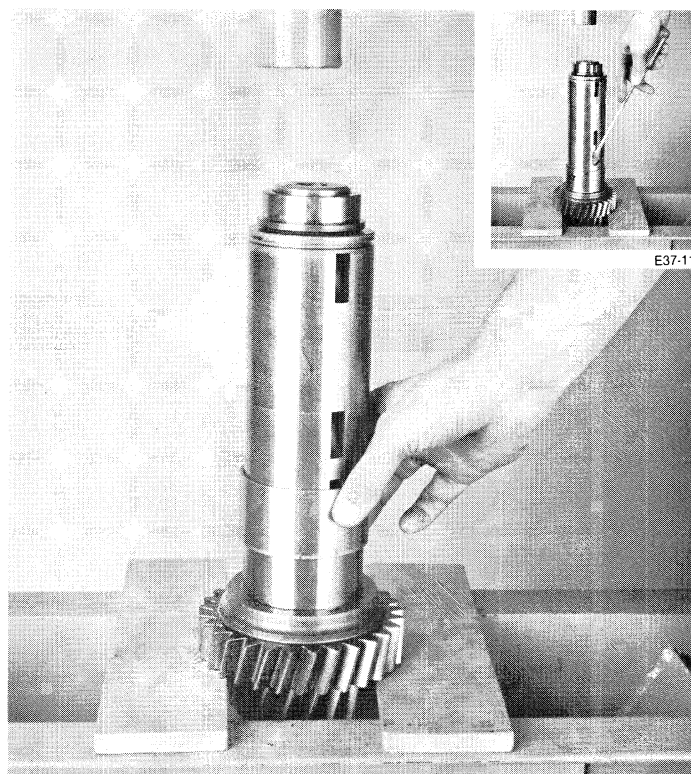

E37-11

37-11

11. Remove 4th speed gear key (inset) and spacer from countershaft.

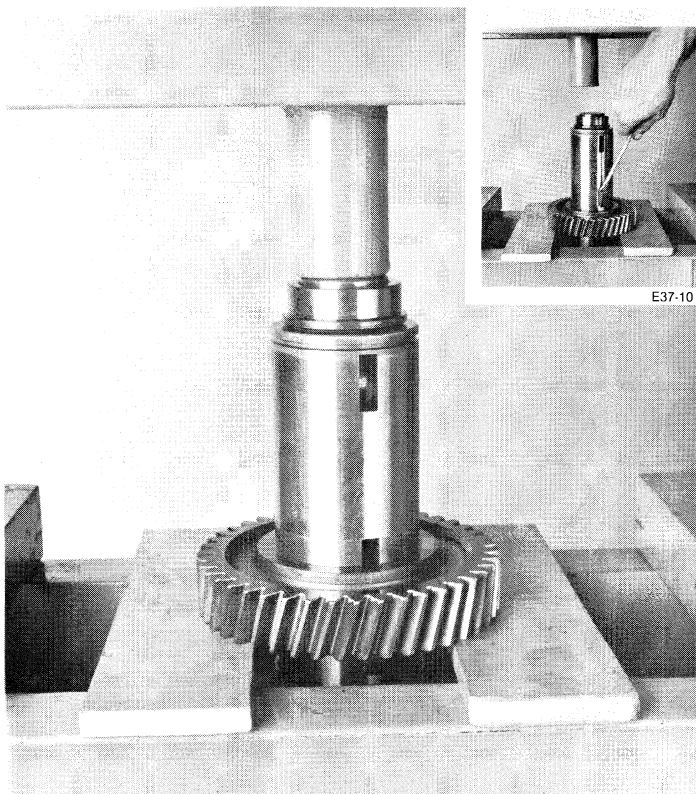

E37-10

37-10

10. Remove 5th speed gear key from shaft (inset). Using the rear face of 4th speed gear as a base, press it from the countershaft.

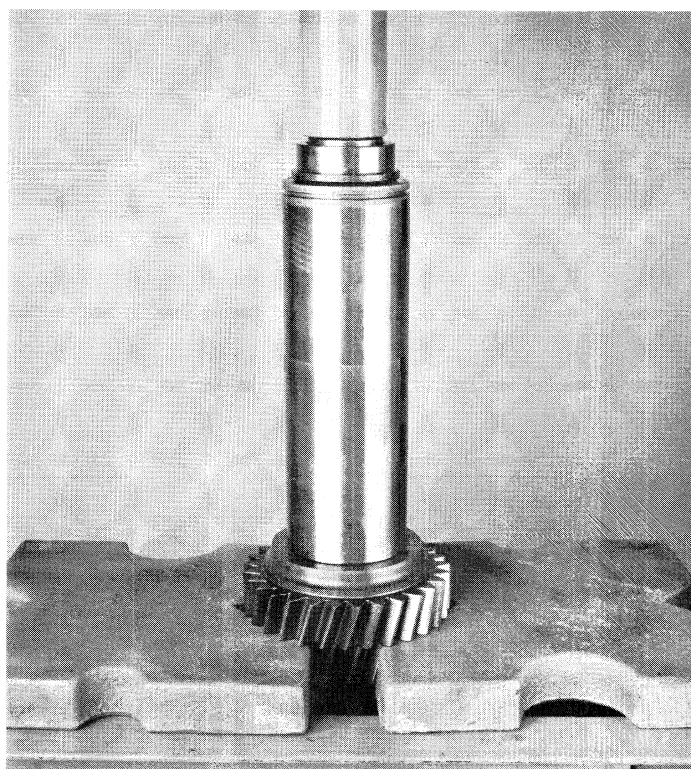

37-12

12. Use the rear face of the 3rd speed gear as a base, then press it from the shaft. If necessary, remove 3rd speed gear key from shaft.

# DISASSEMBLY OF TRANSMISSION

## D. Removal and Disassembly of Reverse Idler

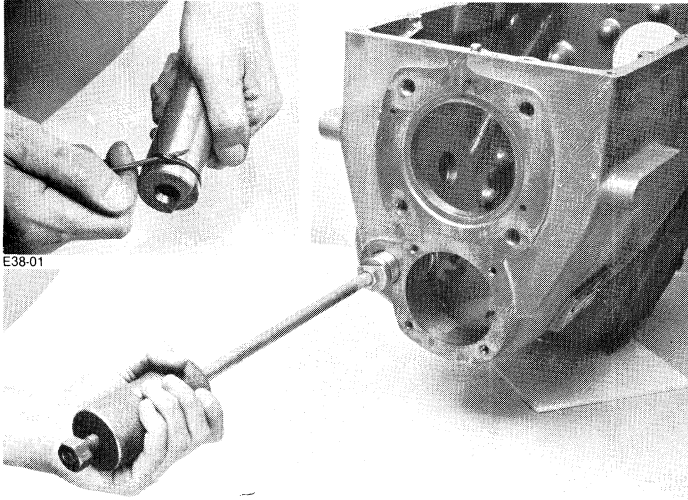

1. With an impact puller, 1/2-13 threaded end, remove idler shaft from bore. Remove O-ring if necessary (inset).

38-01

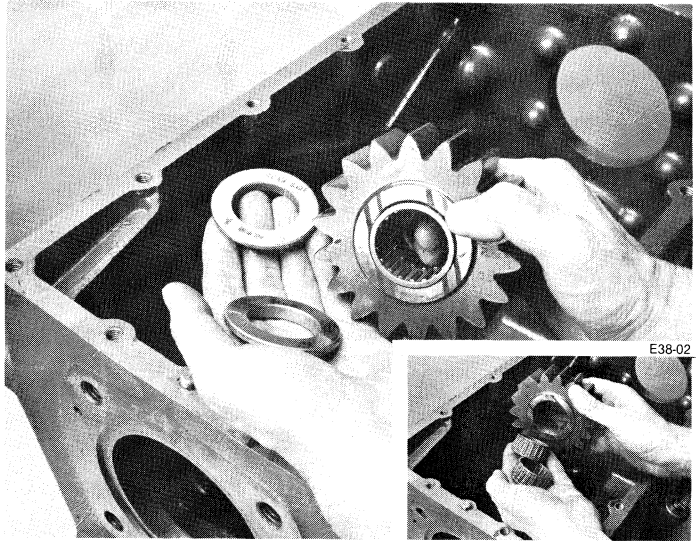

2. Remove reverse idler and thrust washers from case. If necessary, remove bearings from idler gear (inset).

38-02

# REASSEMBLY TRANSMISSION

## A. Reassembly and Installation of Reverse Idler.

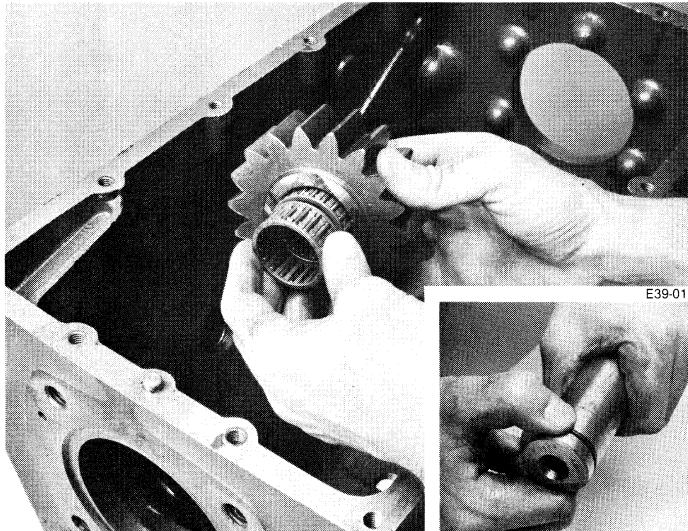

1. If previously removed, install O-ring on idler shaft (inset) and install bearings in idler gear.

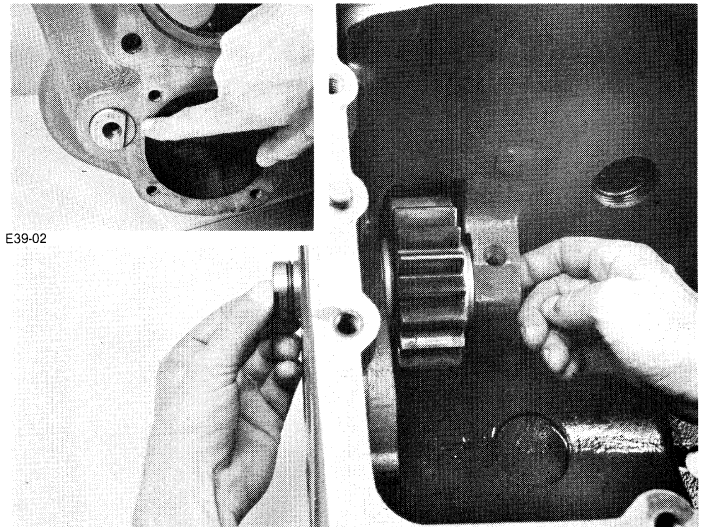

2. Install idler shaft in the case. As the shaft is moved forward, install thrust washer, idler gear, and 2nd thrust washer as shown. **Note:** Align notch in rear of idler shaft in a vertical position towards rear bearing cover (inset).

# REASSEMBLY TRANSMISSION

## B. Reassembly and Installation of Countershaft Assembly

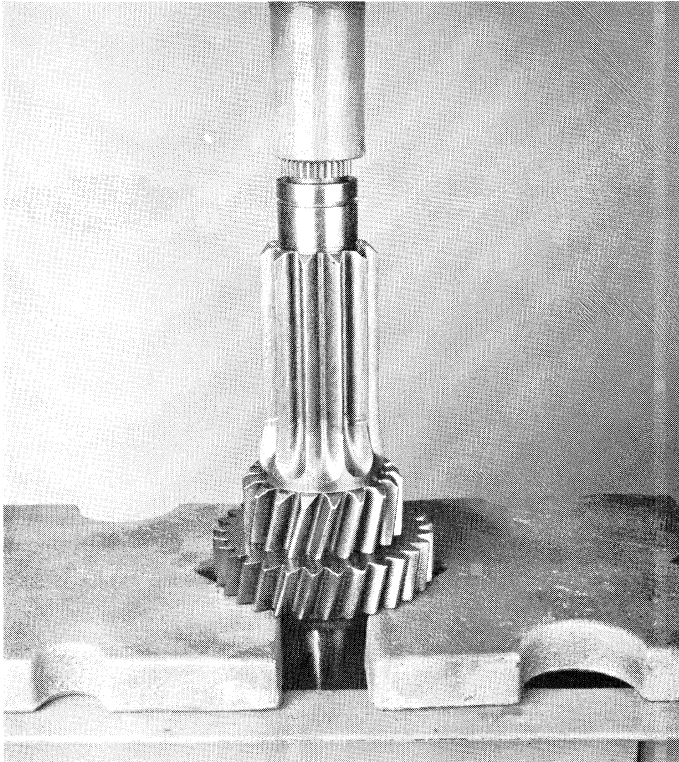

40-01

1. If previously removed, install 3rd speed gear key. Align keyway of gear with key in countershaft and press 3rd speed gear on shaft, long hub of gear to front of countershaft.

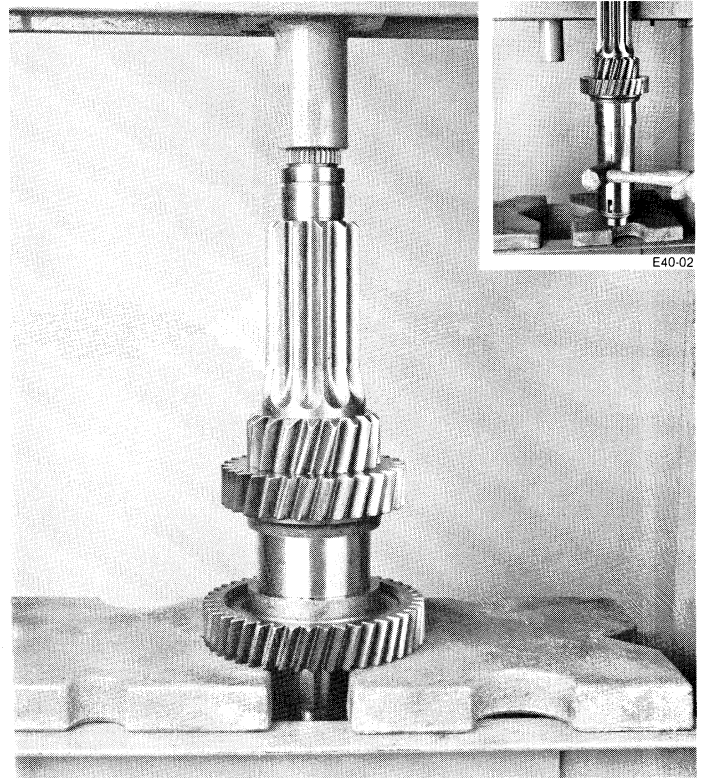

40-02

2. Install spacer and 4th and 5th countershaft key (inset). Align keyway of gear to key in countershaft and press 4th speed gear on shaft, long hub of gear to the rear.



# REASSEMBLY TRANSMISSION

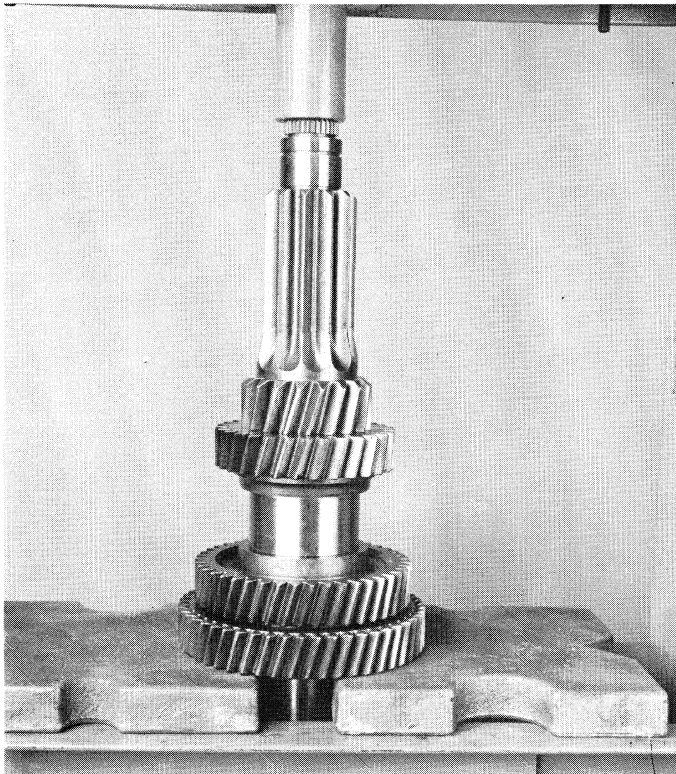

3. Align keyway of 5th speed gear to key on shaft. Press 5th gear on, long hub of gear to the front of the countershaft.

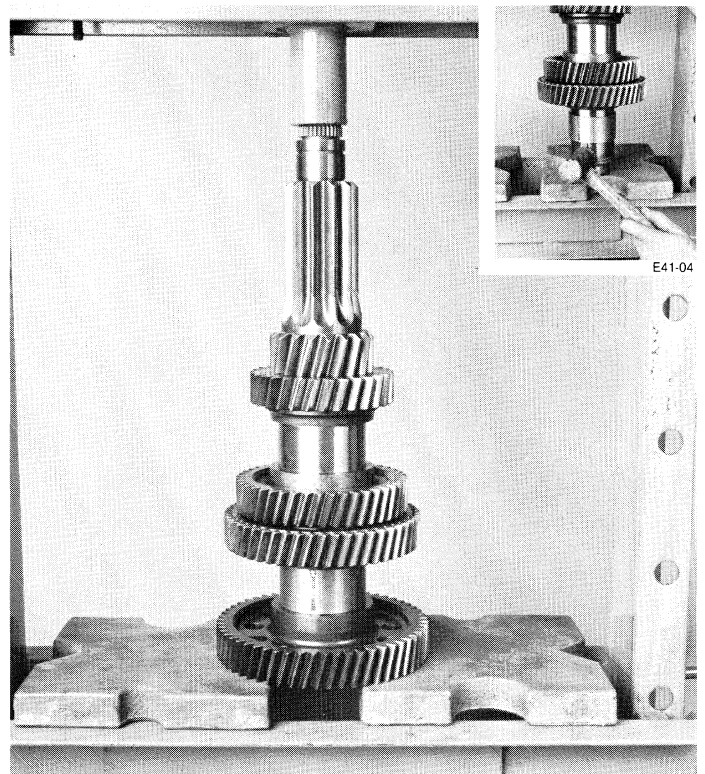

4. Install spacer and drive gear countershaft key (inset). Align keyway of gear to key in countershaft and press drive gear on shaft, long hub of gear to the rear.

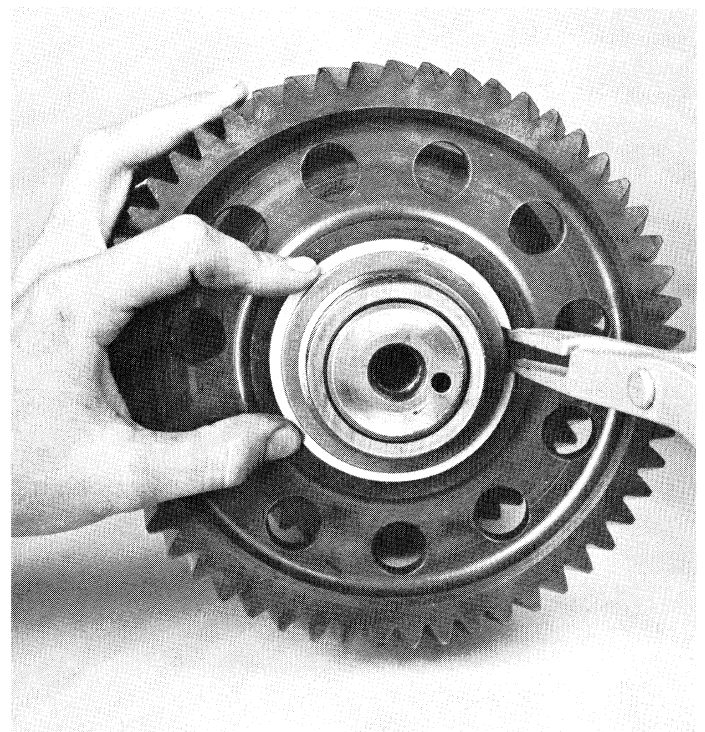

5. Install snap ring in groove at front of countershaft.

# REASSEMBLY TRANSMISSION

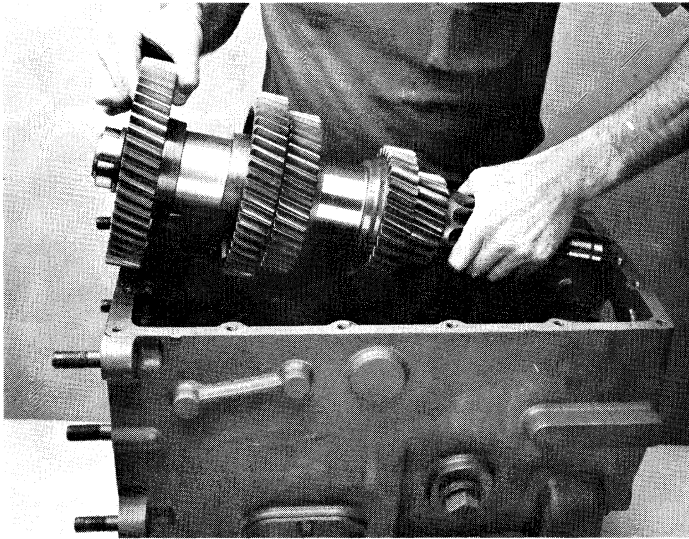

42-06

6. Carefully lower countershaft into case.

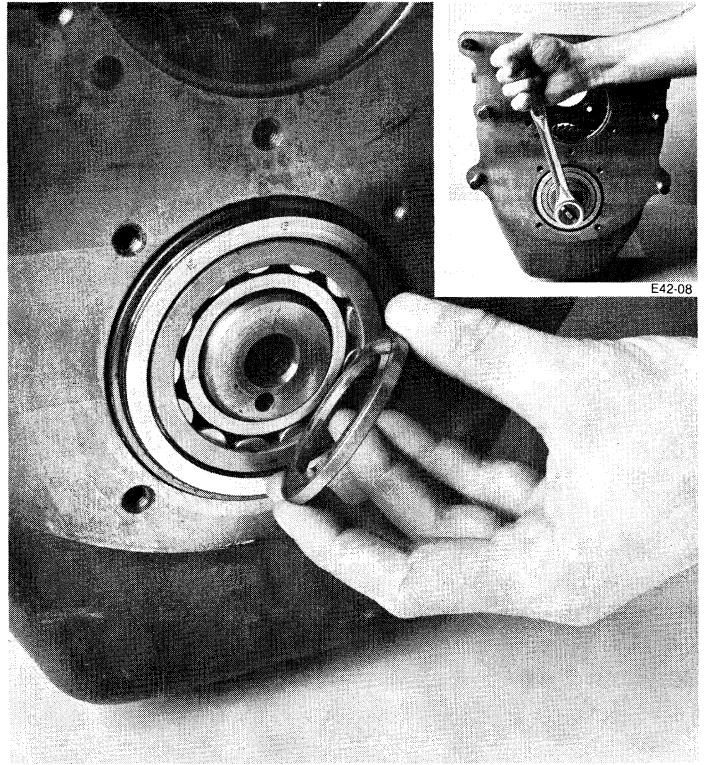

E42-08

42-08

8. Install front countershaft bearing. Groove of bearing spacer towards countershaft. Install countershaft retainer and capscrew (inset).

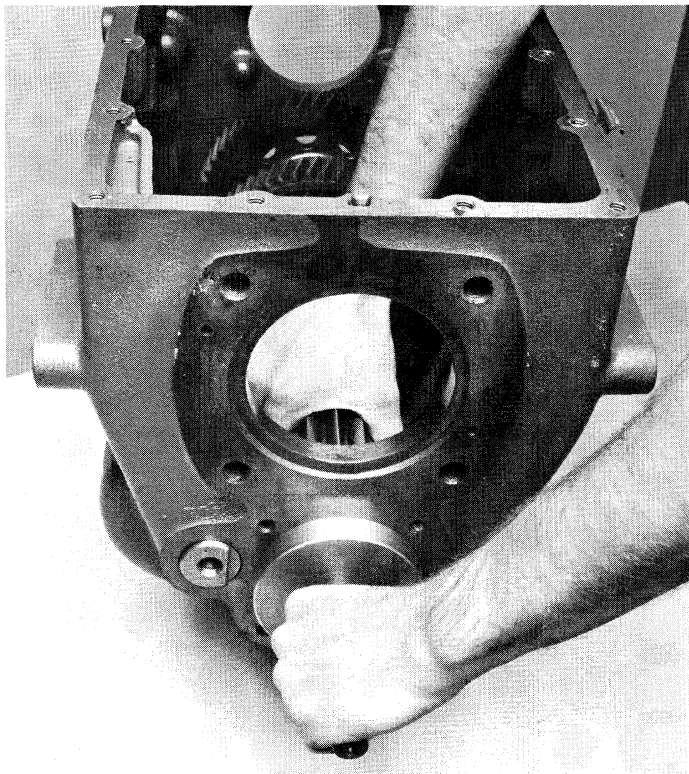

42-07

7. Install countershaft support tool on rear of countershaft to center it in case bore.

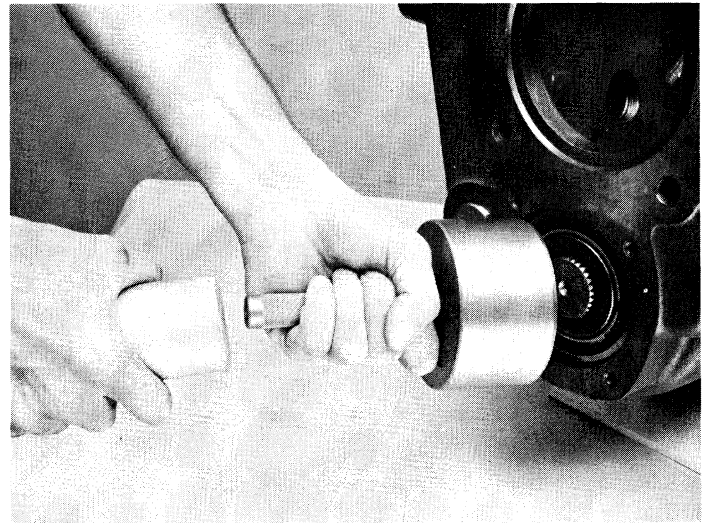

42-09

9. Remove countershaft support tool. Install rear countershaft bearing with chamfered side of bearing toward front of transmission.

# REASSEMBLY TRANSMISSION

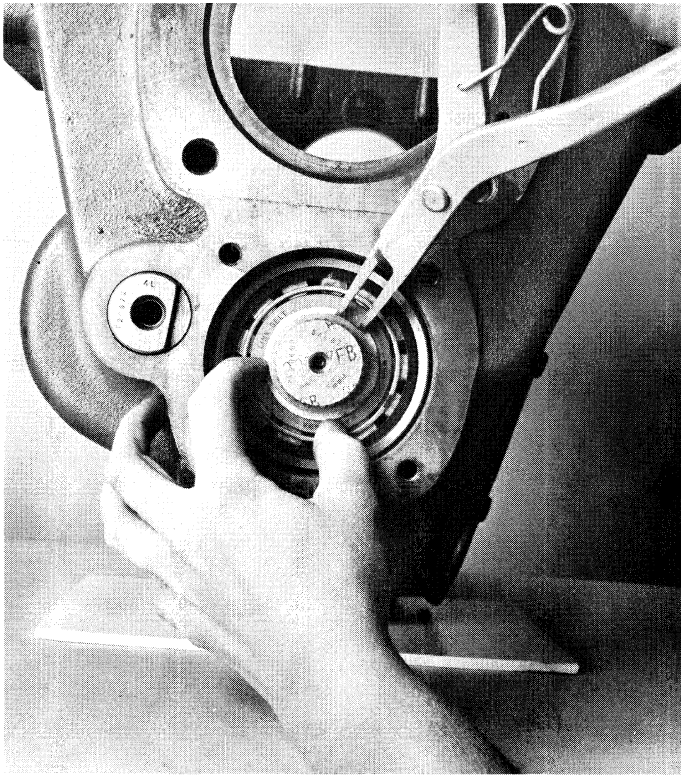

43-10

10. Install snap ring in groove at rear of countershaft.

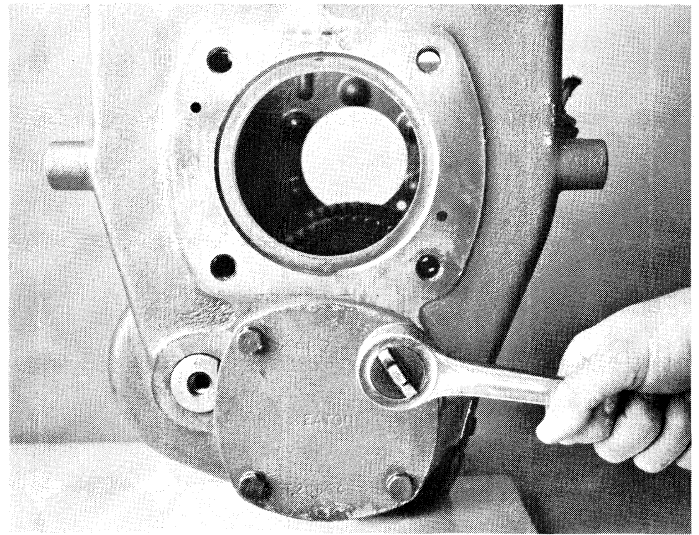

43-11

11. Install rear countershaft bearing cover and gasket. (Note: Machined notch in idler shaft must align with cover.)



# REASSEMBLY TRANSMISSION

## C. Mainshaft Reassembly

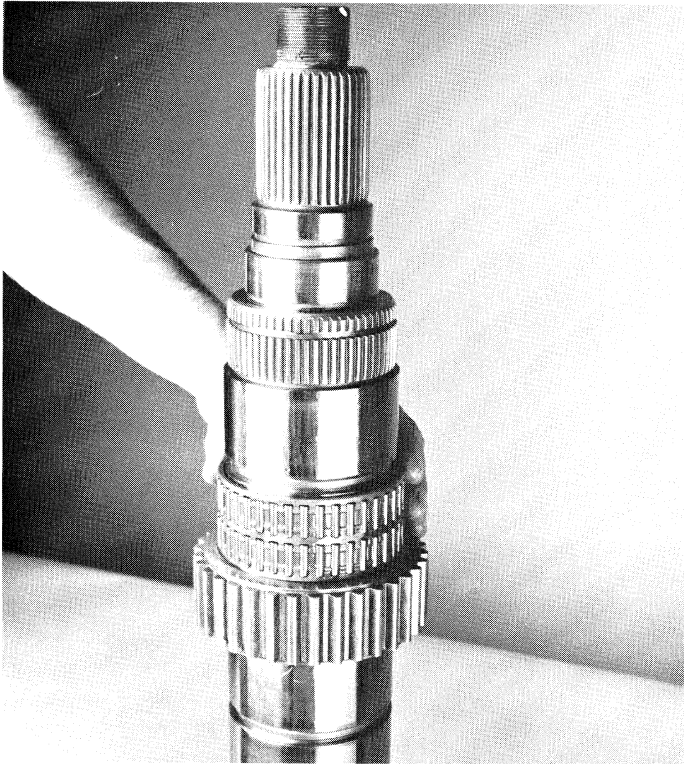

44-01

1. Install mainshaft in vise equipped with wood or brass jaws, rear of main shaft facing up. Lubricate and install 1st gear bearing on shaft.

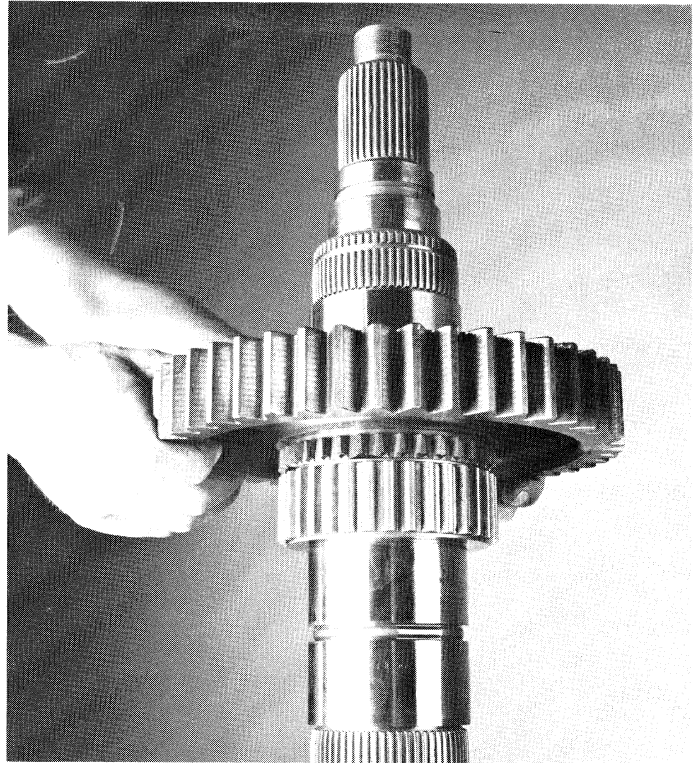

44-02

2. Install mainshaft 1st gear on shaft. Clutching teeth of gear facing down.

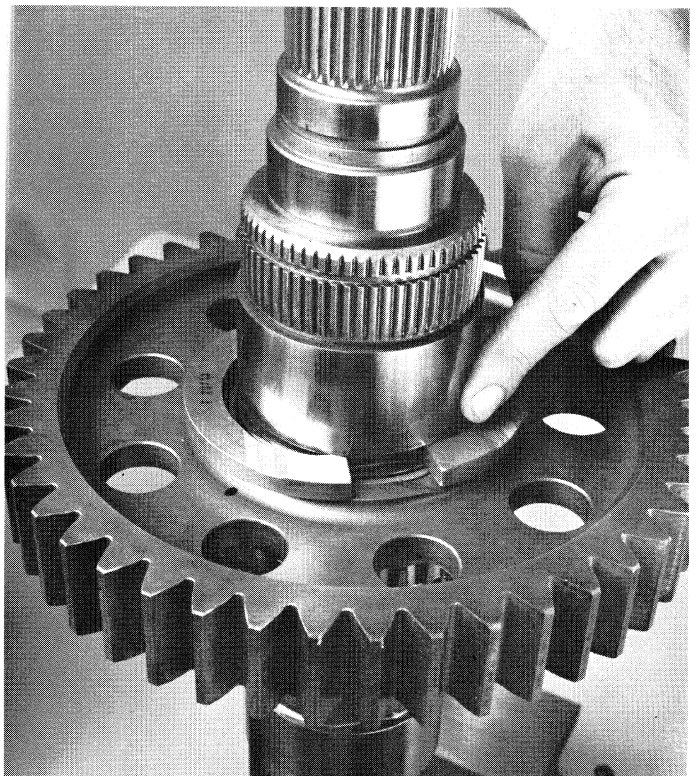

44-03

3. Install split washers in groove of main shaft, aligning internal tangs of split washers with machined slot in groove of shaft.

# REASSEMBLY TRANSMISSION

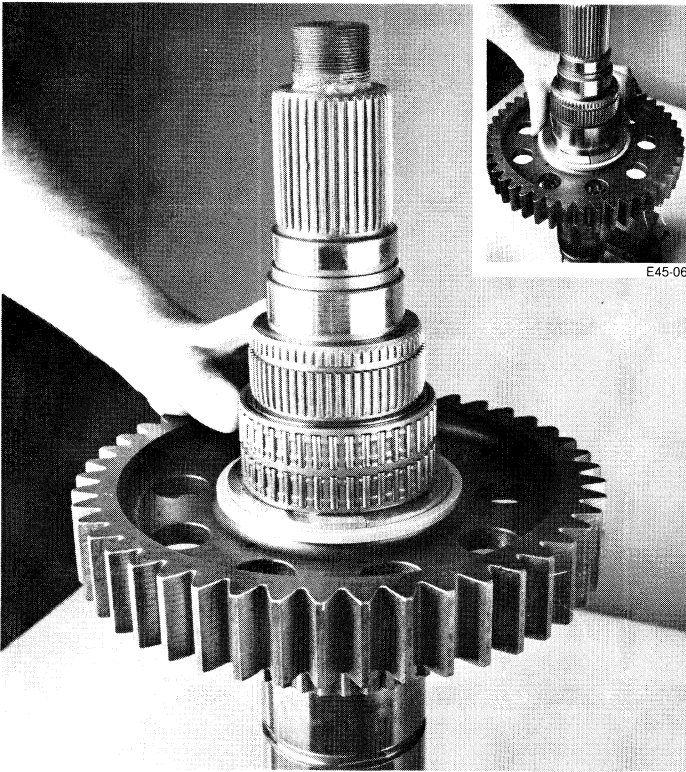

4. Install retainer over split washers (inset). Lubricate and install reverse gear bearing on shaft.

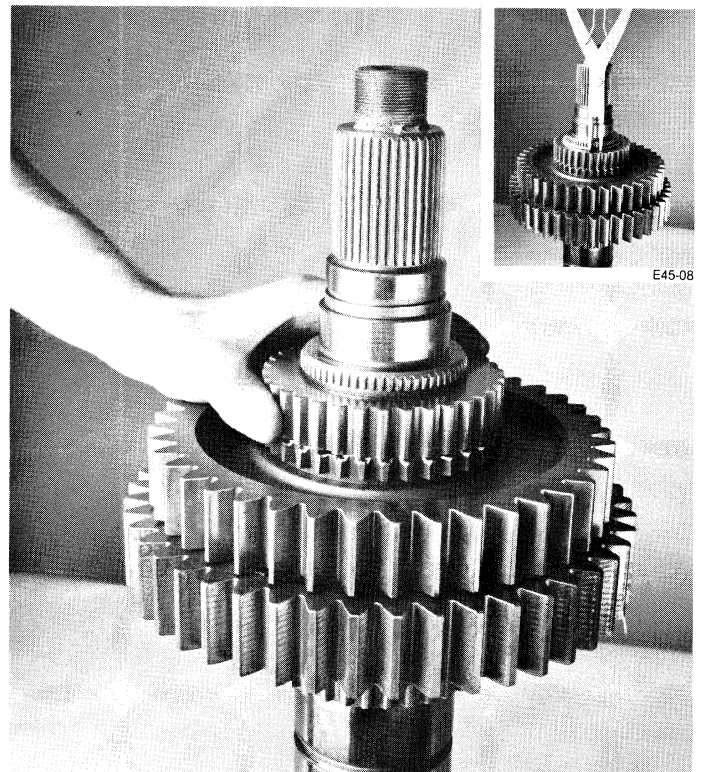

6. Install reverse gear clutch hub on shaft. (Note: Hub is symmetrical, it can be installed either way.) Install snap ring in main shaft (inset).

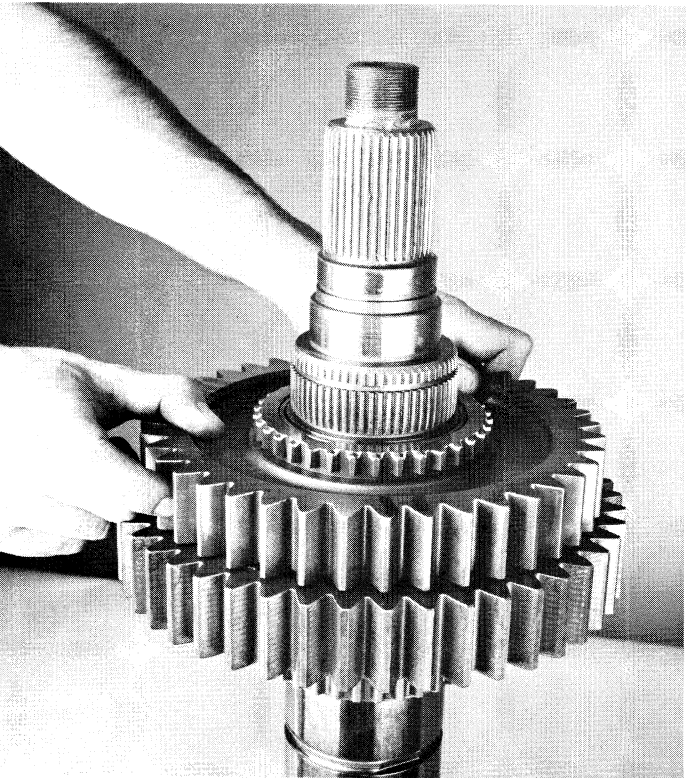

5. Install reverse gear, clutching teeth facing up.



# REASSEMBLY TRANSMISSION

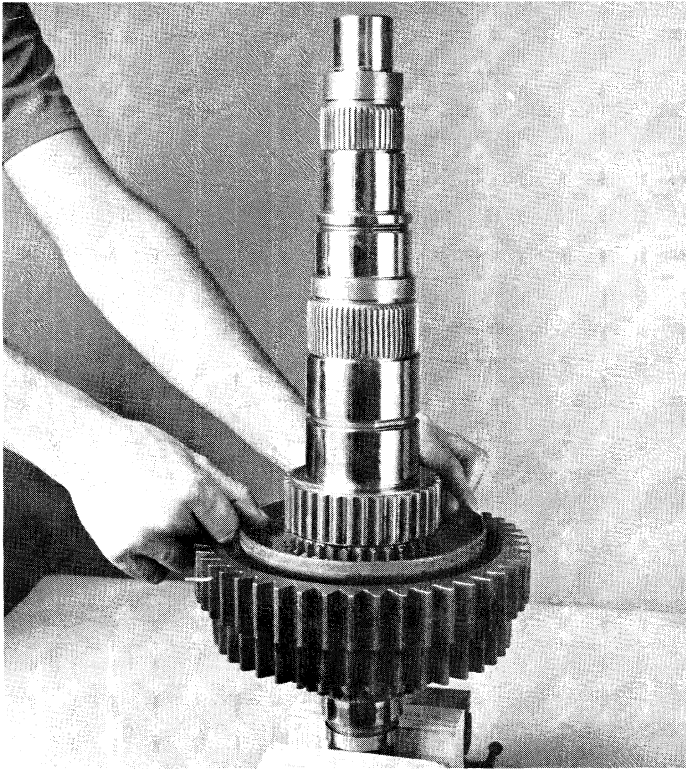

46-10

7. Reposition mainshaft in vise, front of mainshaft now facing up. Install 1st gear synchronizer cup on 1st gear.

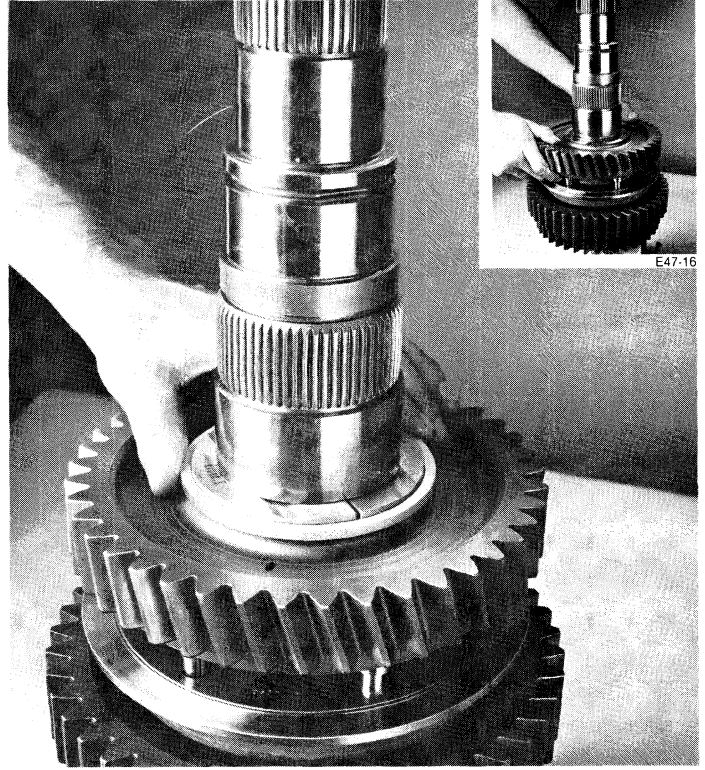

E47-16

47-16

9. Install 2nd gear, clutching teeth facing down (inset), split washers and retaining ring.

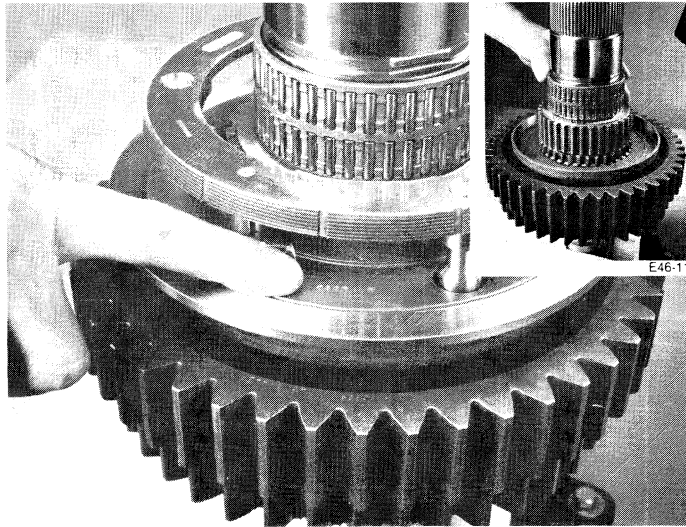

E46-11

47-15

8. Install 2nd gear bearing (inset). Lubricate friction surface with transmission lube and install 1st-2nd synchronizer assembly on main shaft. (**Note:** 1st-2nd synchronizer assembly is Part #A-4992. Number is marked on clutch gear.)

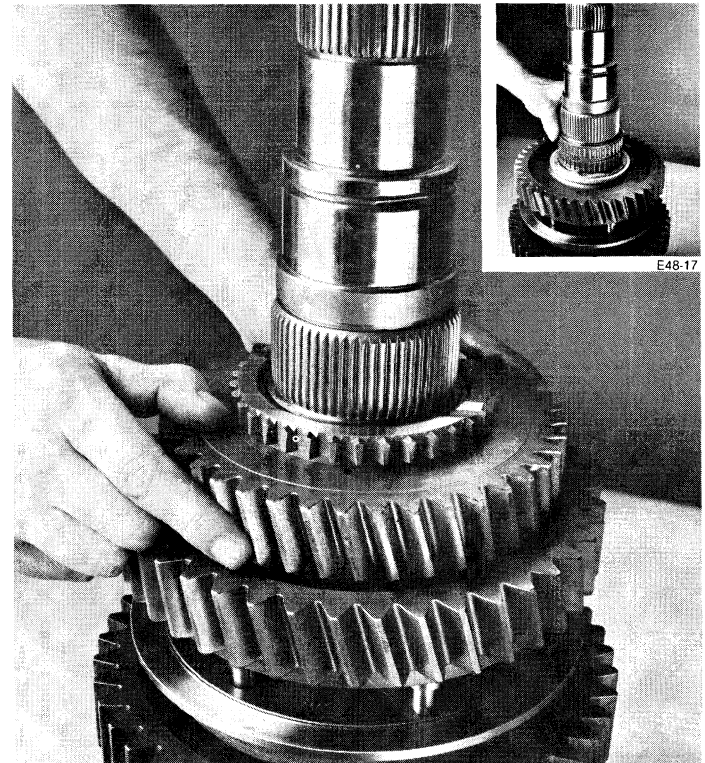

E48-17

48-17

10. Lubricate and install 3rd gear bearing (inset). Install 3rd gear, clutching teeth facing up.

# REASSEMBLY TRANSMISSION

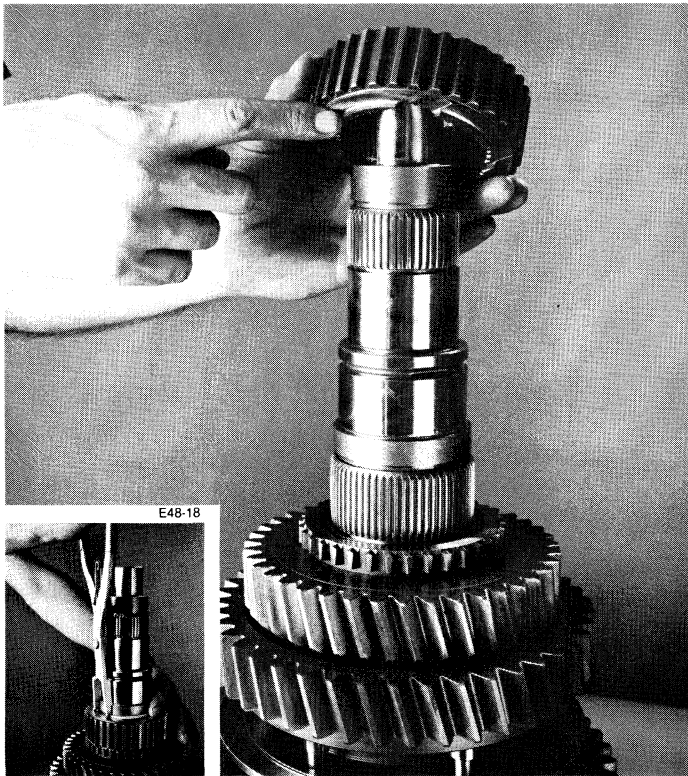

11. Install 3rd-4th clutch hub with shouldered end of hub facing down. Install snap ring in groove of main shaft (inset).

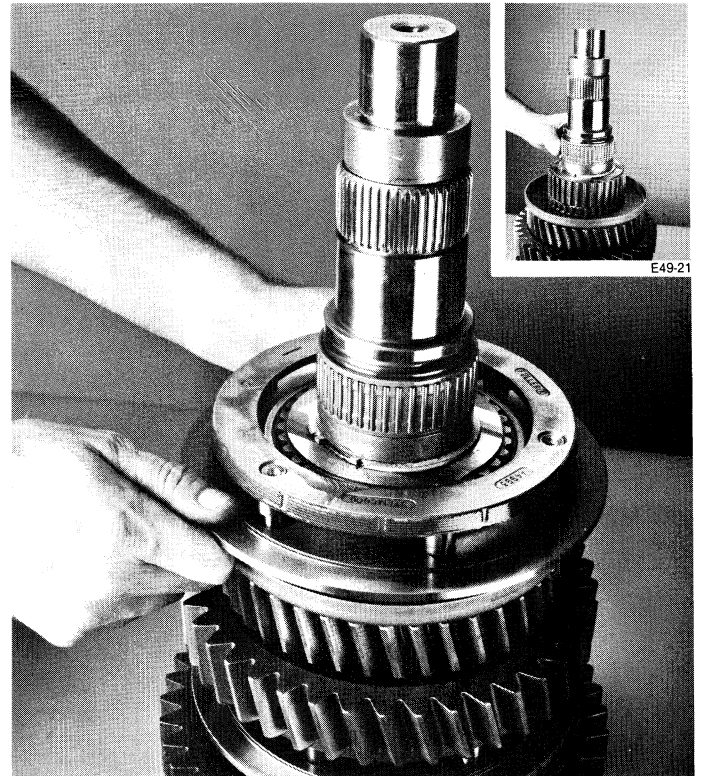

13. Lubricate and install 4th gear bearing (inset). Lubricate friction surface with transmission lube and install 3rd-4th synchronizer.

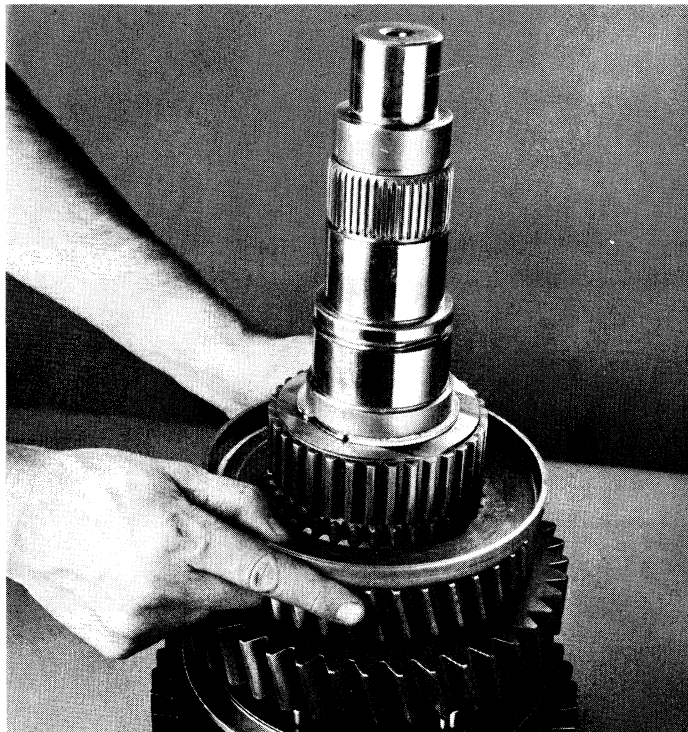

12. Install 3rd gear synchronizer cup.

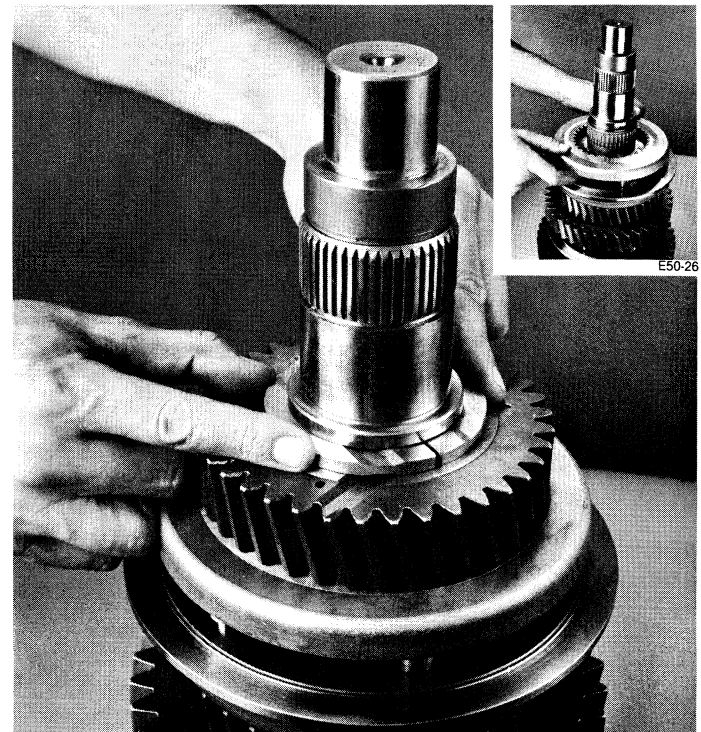

14. Install 4th gear synchronizer cup (inset). Install 4th gear, clutching teeth facing down. Install split washers.



# REASSEMBLY TRANSMISSION

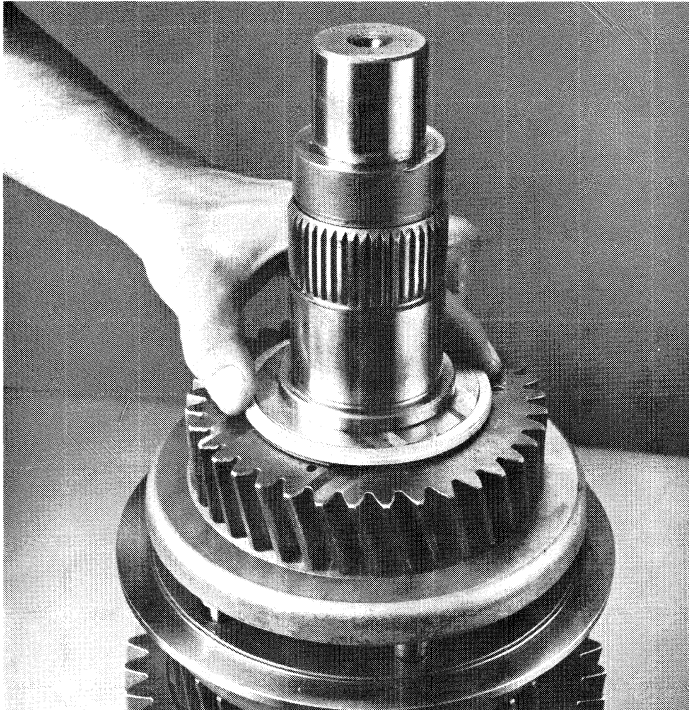

15. Install retaining ring over split washers.

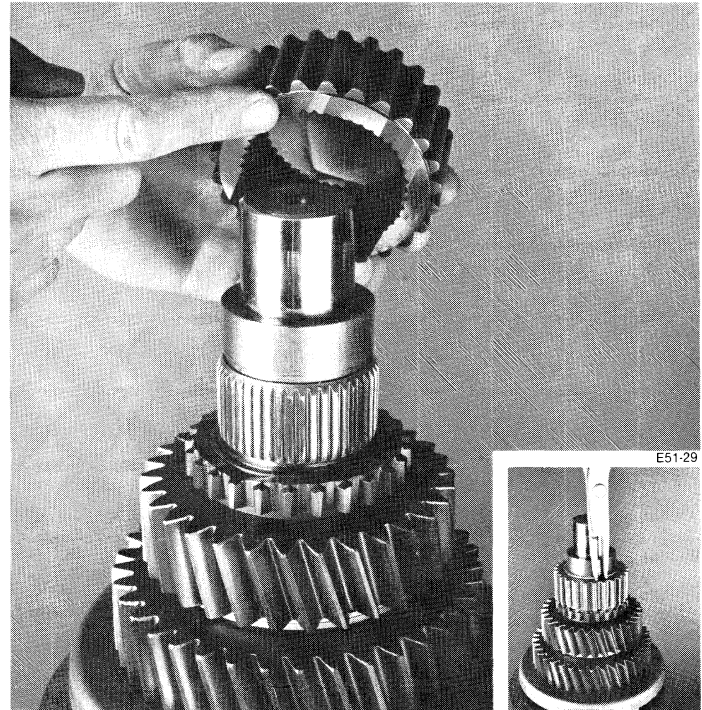

17. Install 5th-6th clutch hub on main shaft. End of hub with machined slots facing down. Install snap ring in groove of main shaft in front of clutch hub (inset).

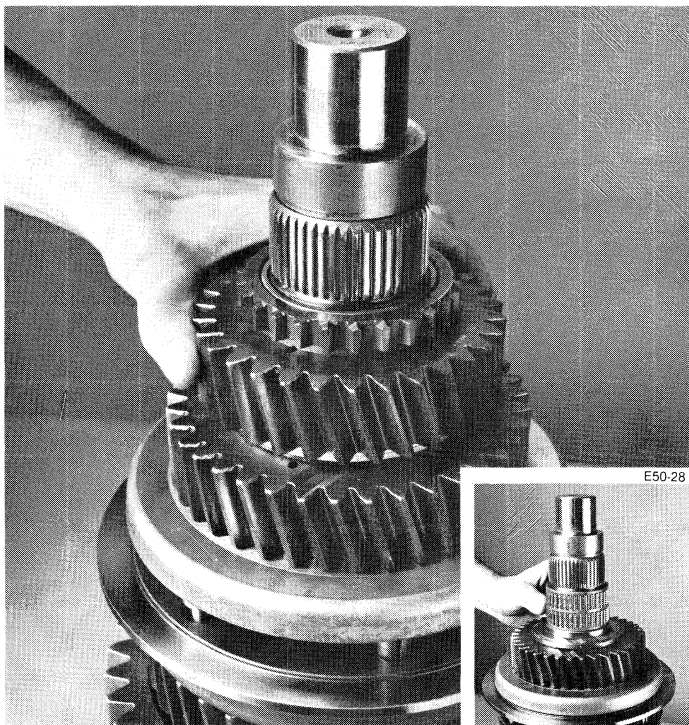

16. Lubricate and install 5th gear bearing on shaft (inset). Install 5th gear, clutching teeth facing up.



18. Install 5th gear synchronizer cup (inset). Lubricate friction surface with transmission lube and install 5th-6th synchronizer assembly and 6th gear synchronizer cup.

# REASSEMBLY TRANSMISSION

---

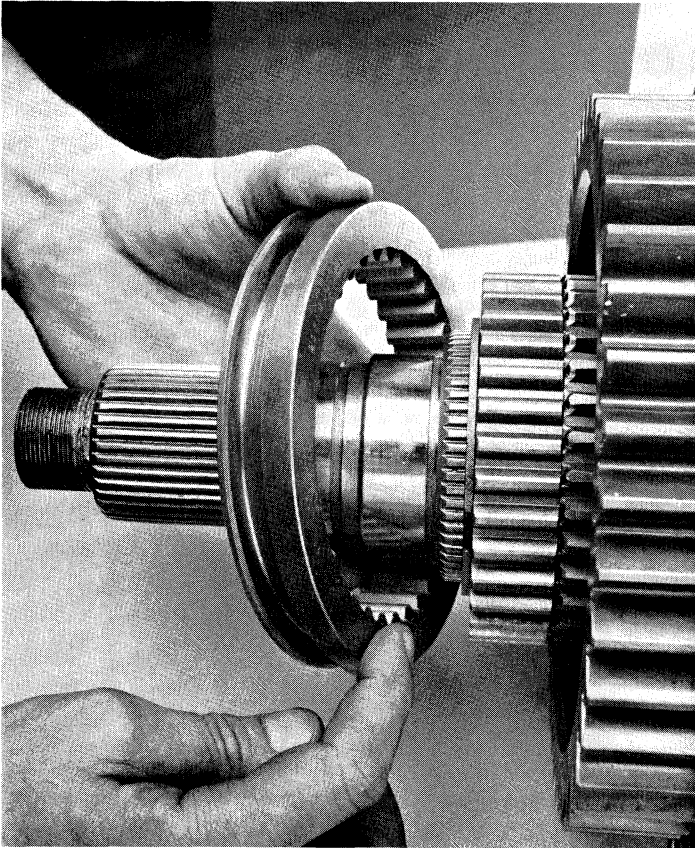

51-32

19. Remove main shaft assembly from vise and lay on bench. Install reverse gear sliding clutch on rear of main shaft with clutching teeth facing toward the front of shaft.

# REASSEMBLY TRANSMISSION

## D. Mainshaft Installation

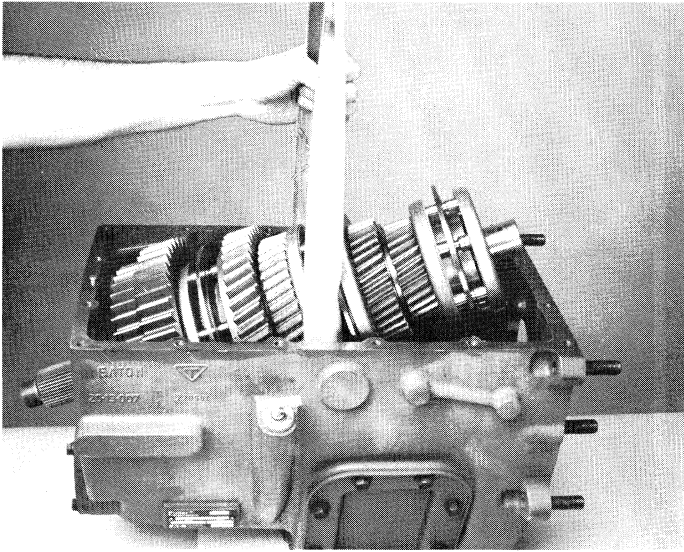

53-01

1. Wrap sling around mainshaft as shown. Use hoist to install mainshaft assembly into case. **Note:** Use caution as assembly weighs approximately 130 lbs.

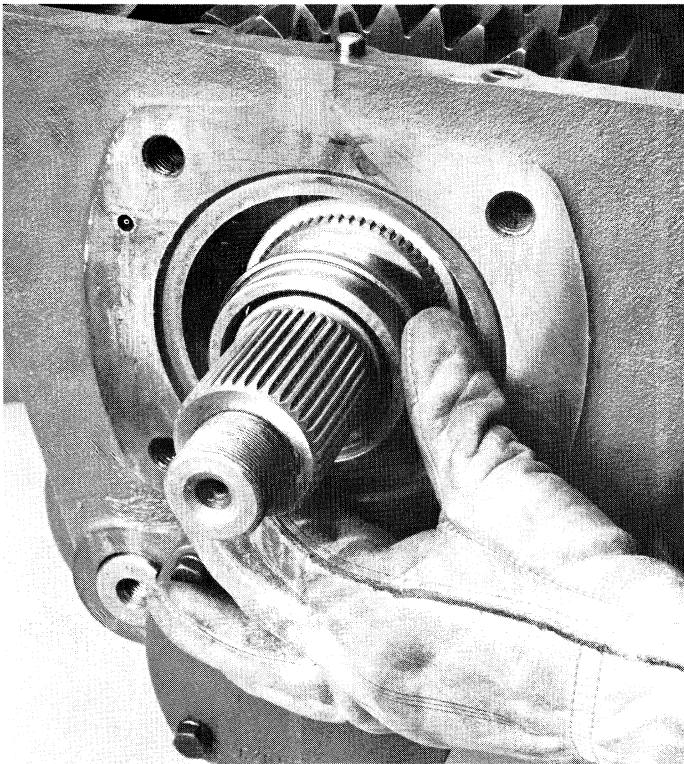

53-02

2. Using heat lamp or hot plate and oil, heat mainshaft rear bearing race and install it on mainshaft as shown.

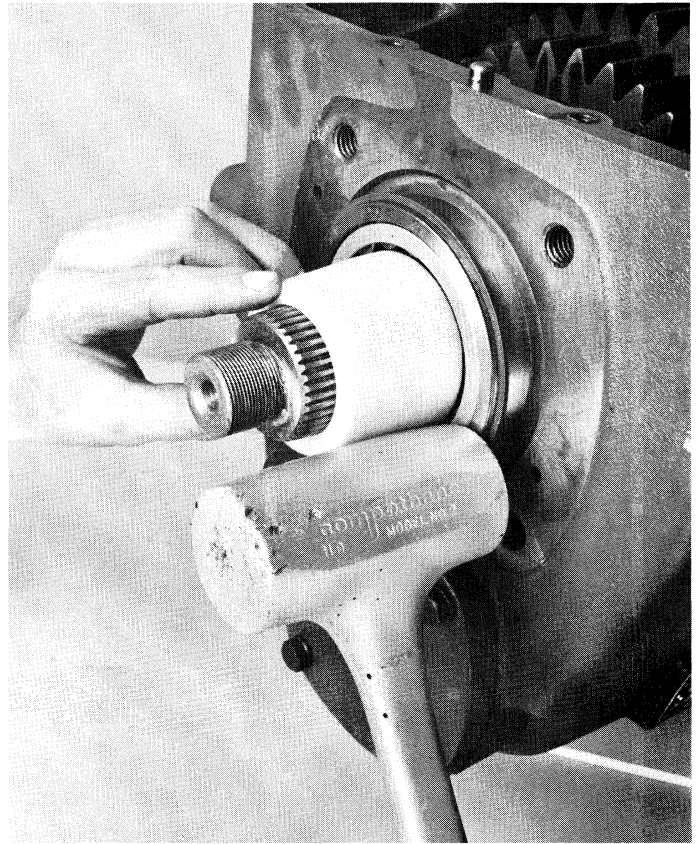

53-03

3. Lubricate and install rear mainshaft bearing. **Note:** To prevent damaging bearing, center mainshaft with rollers as bearing starts over race. A bearing guide (shown) will ease installation.

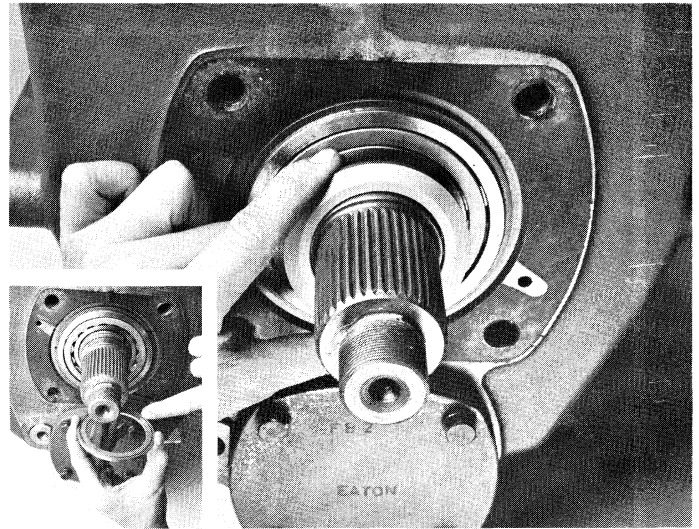

53-04

4. Install bearing spacer, groove towards bearing (inset). Install chamfered washer as shown.



# REASSEMBLY TRANSMISSION

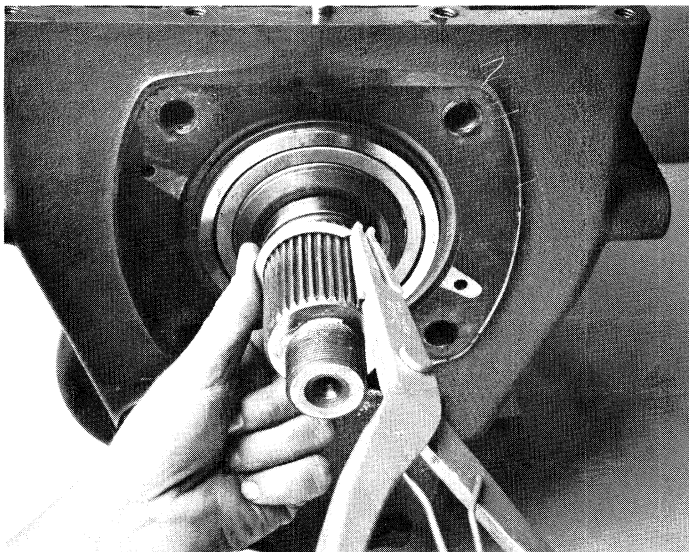

54-05

5. Install snap ring in groove of main shaft.

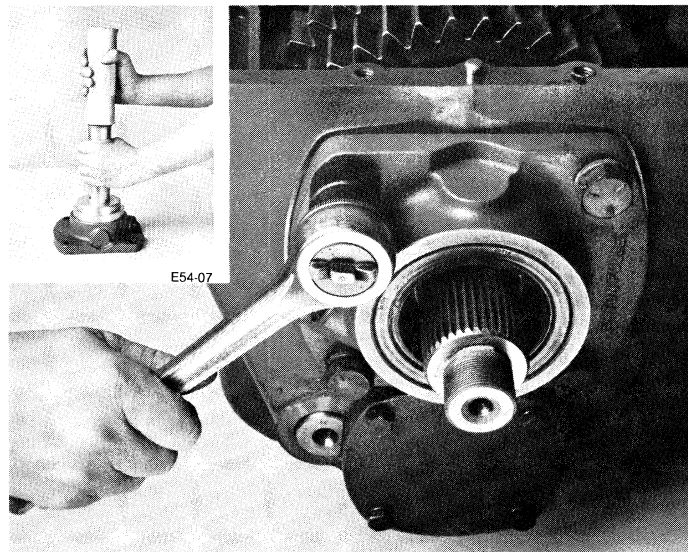

E54-07

54-07

7. If previously removed, install seal in rear bearing cover (inset). Install rear bearing cover, gasket, and retaining capscrews. Tighten capscrews to 145-155 lbs. ft.

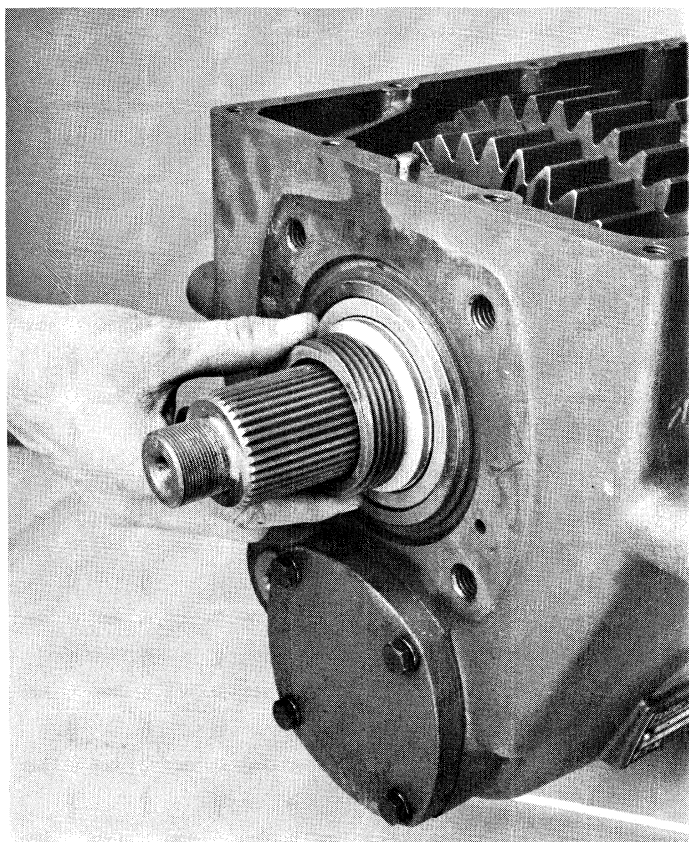

54-06

6. Install speedometer drive gear.

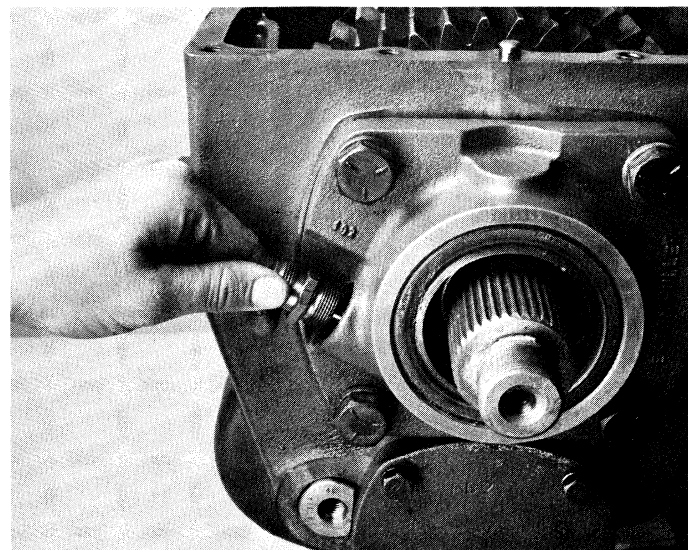

54-08

8. Install speedometer driven gear and sleeve.

# REASSEMBLY TRANSMISSION

## E. Reassembly and Installation of Input Shaft Assembly

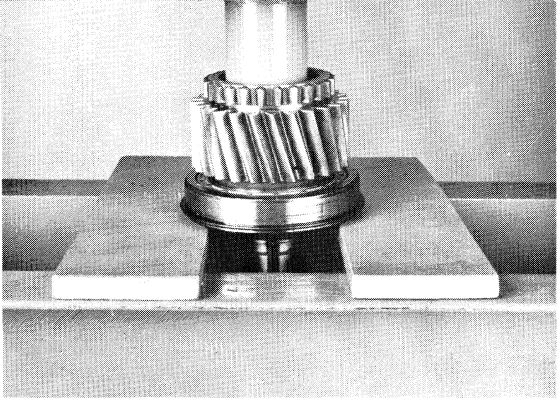

55-01

1. Press input shaft thru bearing. Refer to illustration for proper bearing assembly.

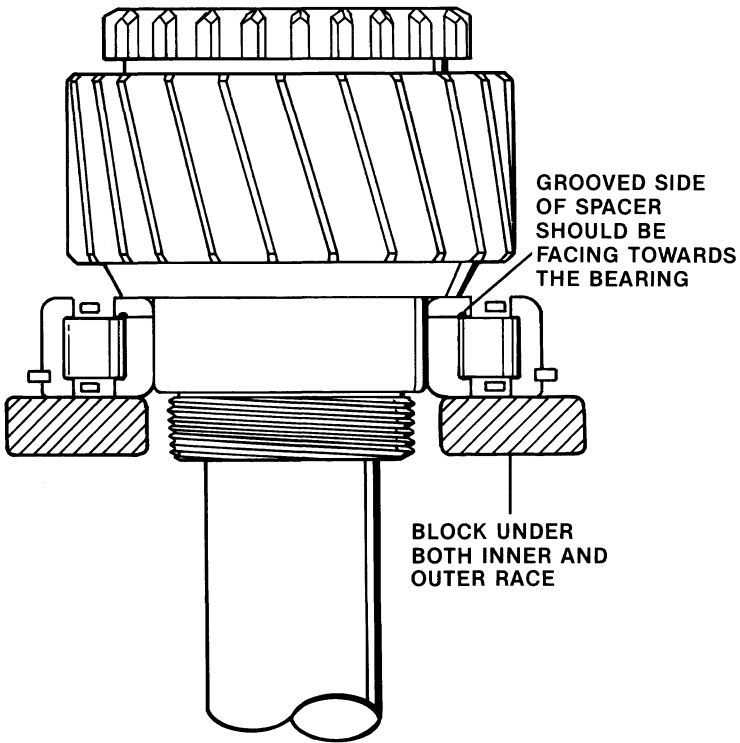

Cut 7388-12/85

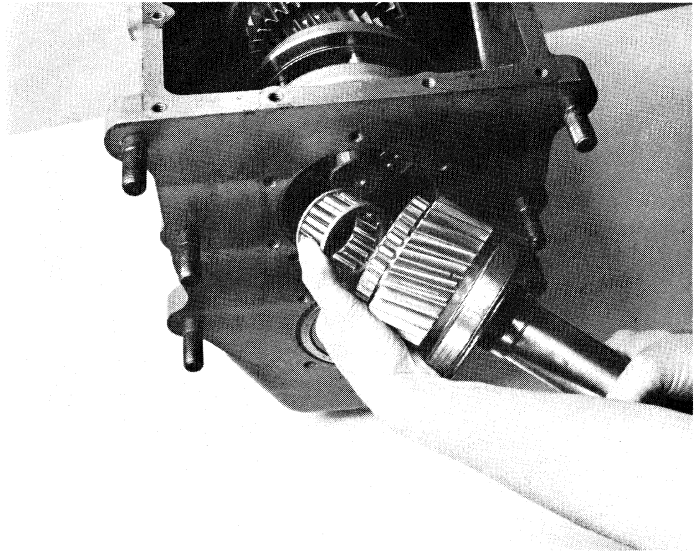

55-02

2. Lubricate and install spigot bearing in drive gear and install input shaft assembly in case bore aligning drive gear clutching teeth with those of synchronizer cup.

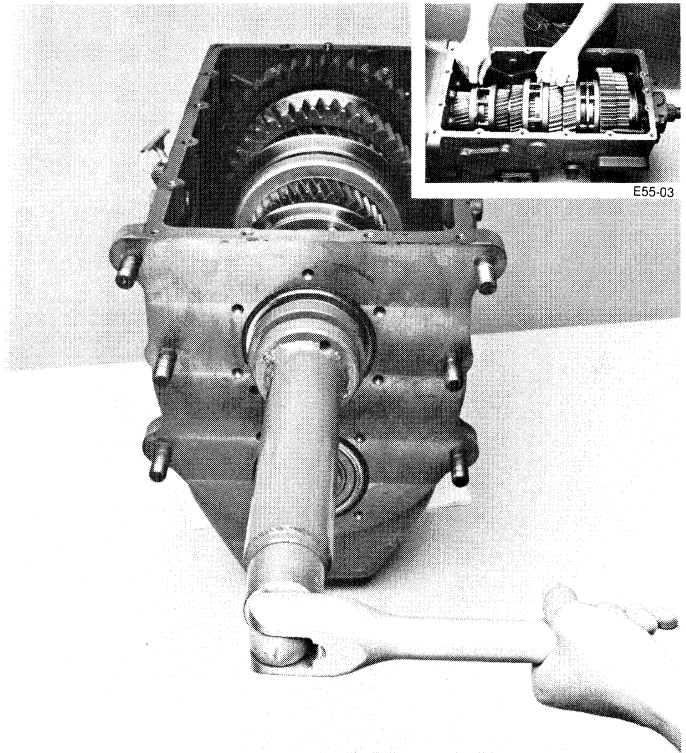

3. Apply Fuller Adhesive Sealant (part no. 71204) to threads of nut and install nut on input shaft. Shift transmission into two gears (inset) and torque nut to 250-300 lbs. ft. Stake nut into two milled slots of input shaft.

# REASSEMBLY TRANSMISSION

---

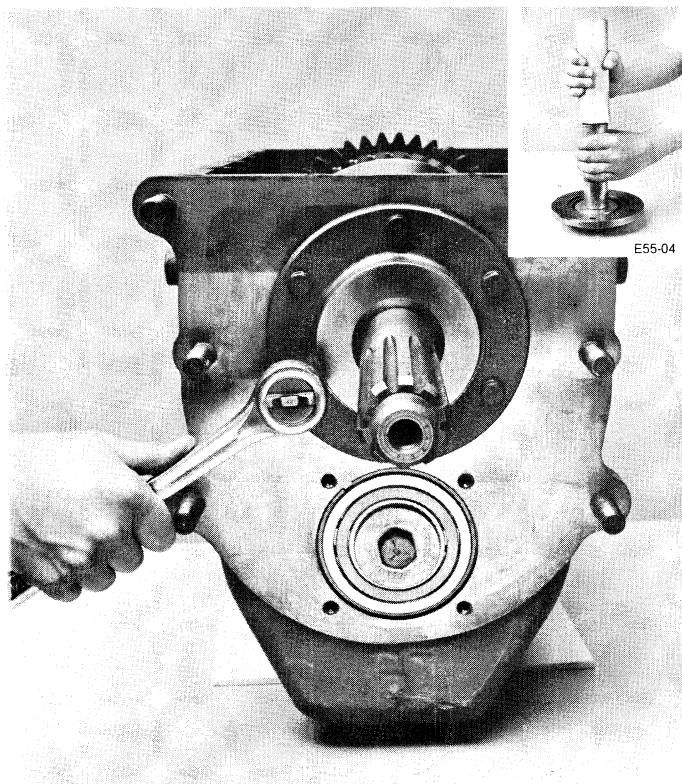

4. If previously removed, install seal in bearing cover with a flanged driver (inset). Install input shaft bearing cover and gasket. Install retaining capscrews and torque to 35-45 lbs. ft. **Note:** Apply a light coat of Loctite 510 to outside diameter of seal before installation.

# INSTALLATION — CLUTCH HOUSING AND REAR YOKE

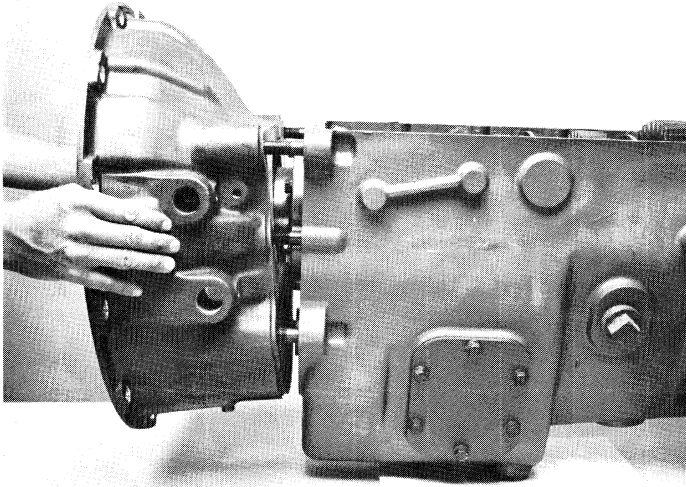

L56-01

1. Position gasket and install clutch housing (above). Install six nuts and washers on studs (torque to 140-150 lbs. ft.). Install and torque four clutch housing capscrews ( $3/8$ "-16  $\times$  1-1/4") to 35-45 lbs. ft. (below).

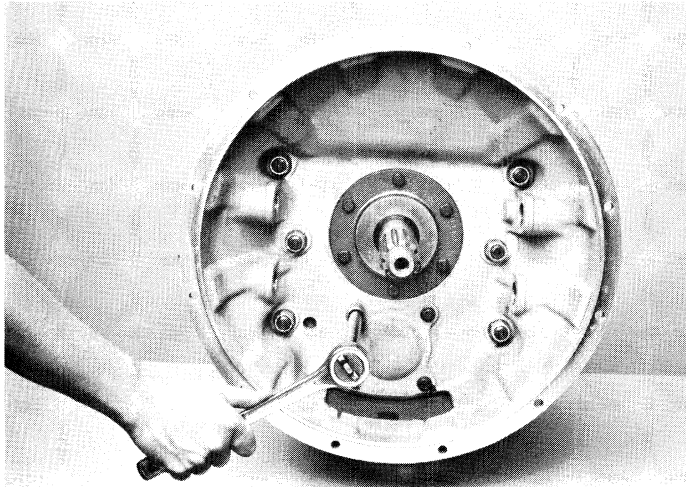

R56-01

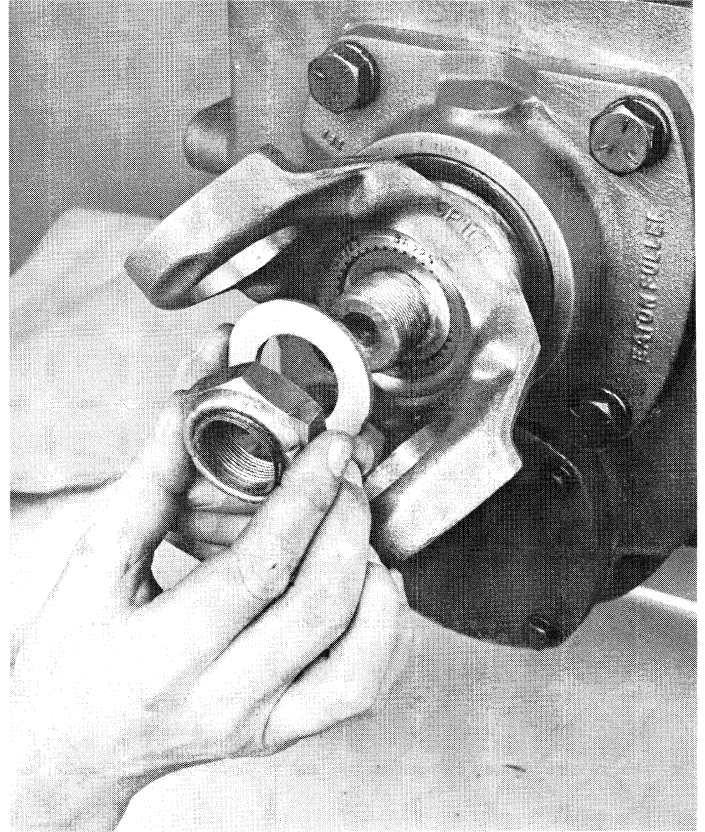

56-02

2. Install rear yoke, spacer, and nut. Lock transmission into two gears and torque nut to 235-275 lbs. ft.



# INSTALLATION - SHIFTING CONTROLS

## A. Shift Bar Housing

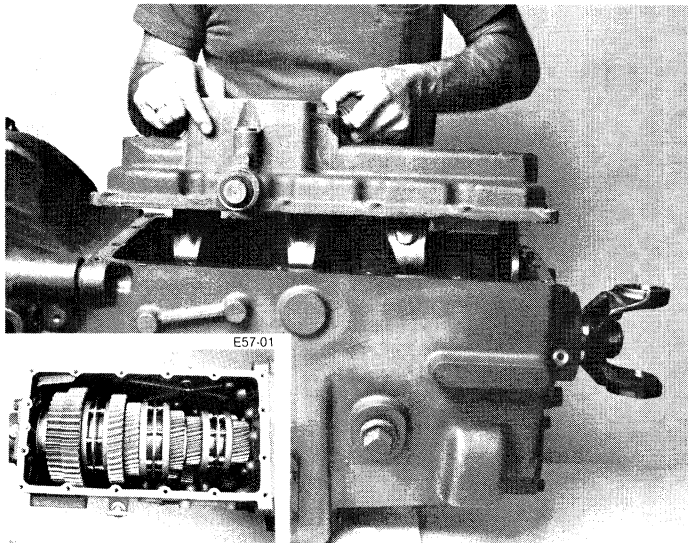

57-01

1. Place transmission in neutral (inset) and install gasket on case. Place shift bar housing in neutral and install on case making sure shift yokes align with corresponding synchronizers and sliding clutch.

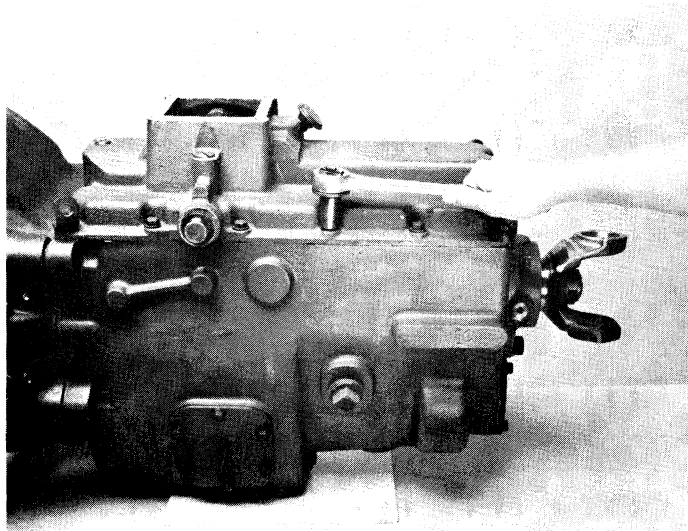

57-02

2. Install capscrews into housing and torque to 35-45 lbs. ft. **Note:** The two capscrews that retain the lifting eyes are  $\frac{3}{8}$ "  $\times$  16  $\times$  1- $\frac{1}{2}$ ". All other bar housing retaining capscrews are  $\frac{3}{8}$ "-16  $\times$  1- $\frac{1}{4}$ ".

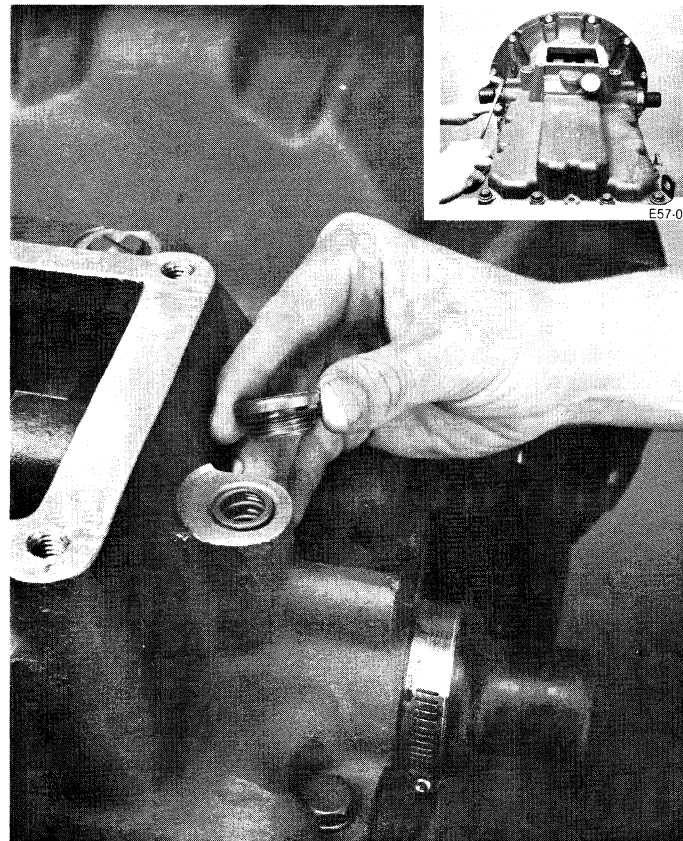

57-03

3. Install boots and clamps (inset). Install detent pin, spring gasket, and plug.



# INSTALLATION - SHIFTING CONTROLS

## B. Gear Shift Lever Housing Assembly

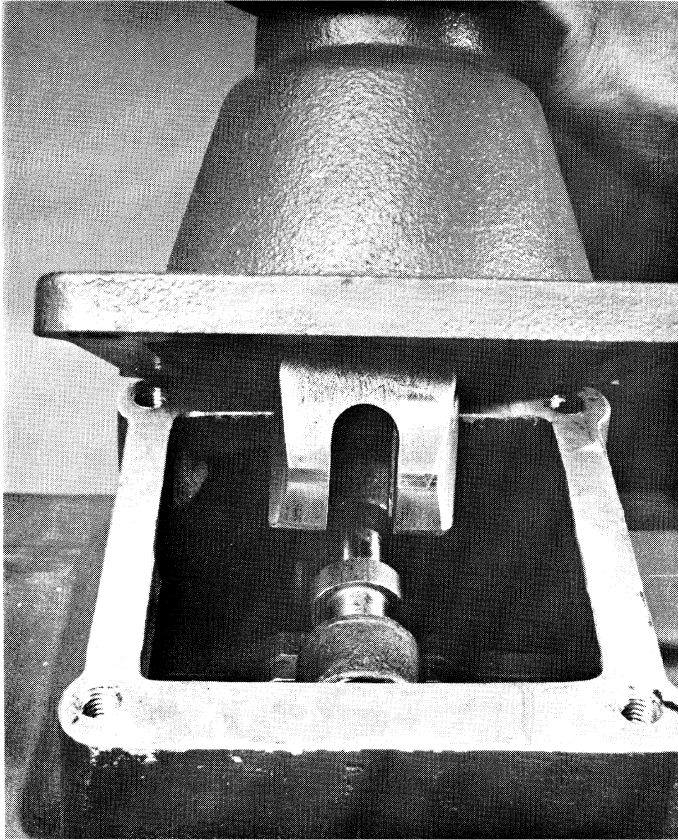

58-01

1. With the shift bar housing in the neutral position, install gasket and gearshift lever assembly on the bar housing. Fit gear shift lever on corresponding finger assembly in bar housing as lever assembly is installed.

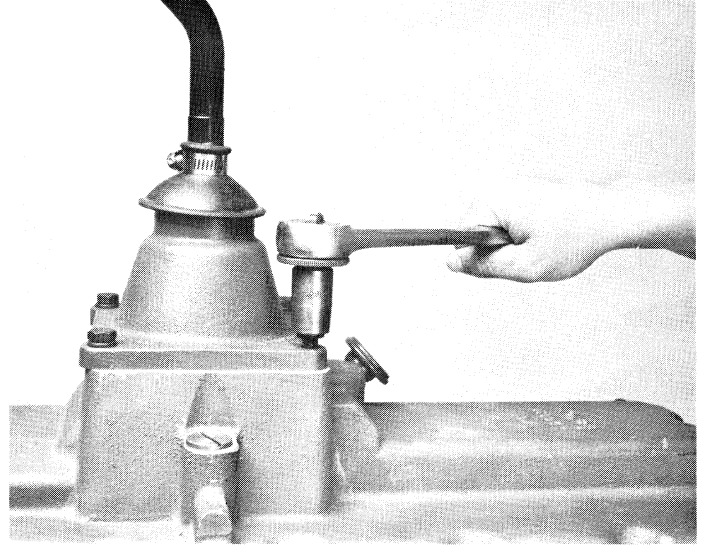

58-02

2. Install retaining capscrews and torque to 30-40 lbs. ft.

# OPTIONS

## REAR BEARING COVER 12 x 4 BRAKE

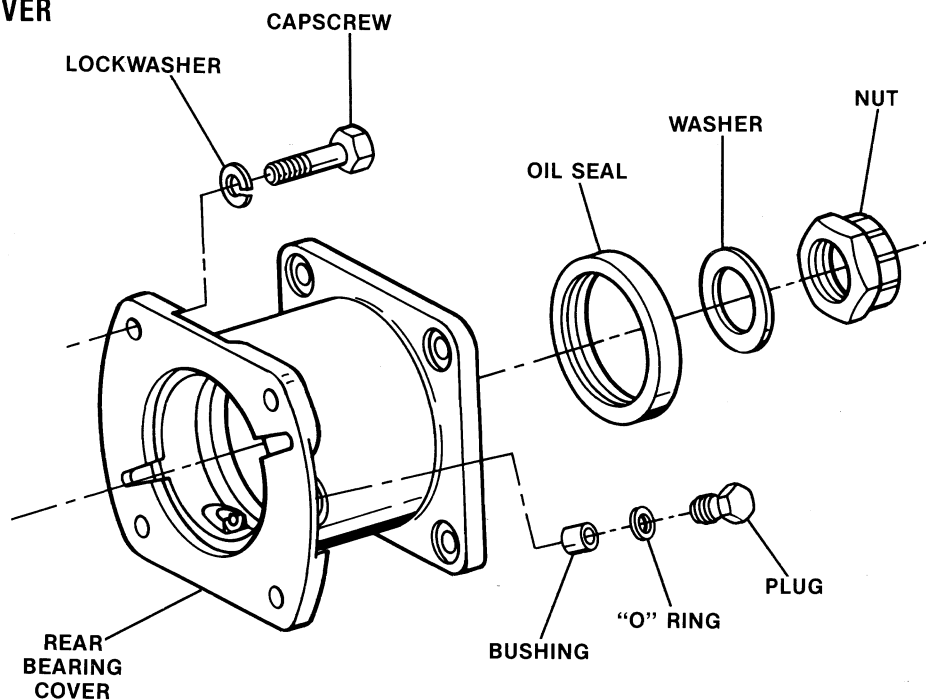

Cut 7193M-2/86

## REMOTE CONTROL ASSEMBLY

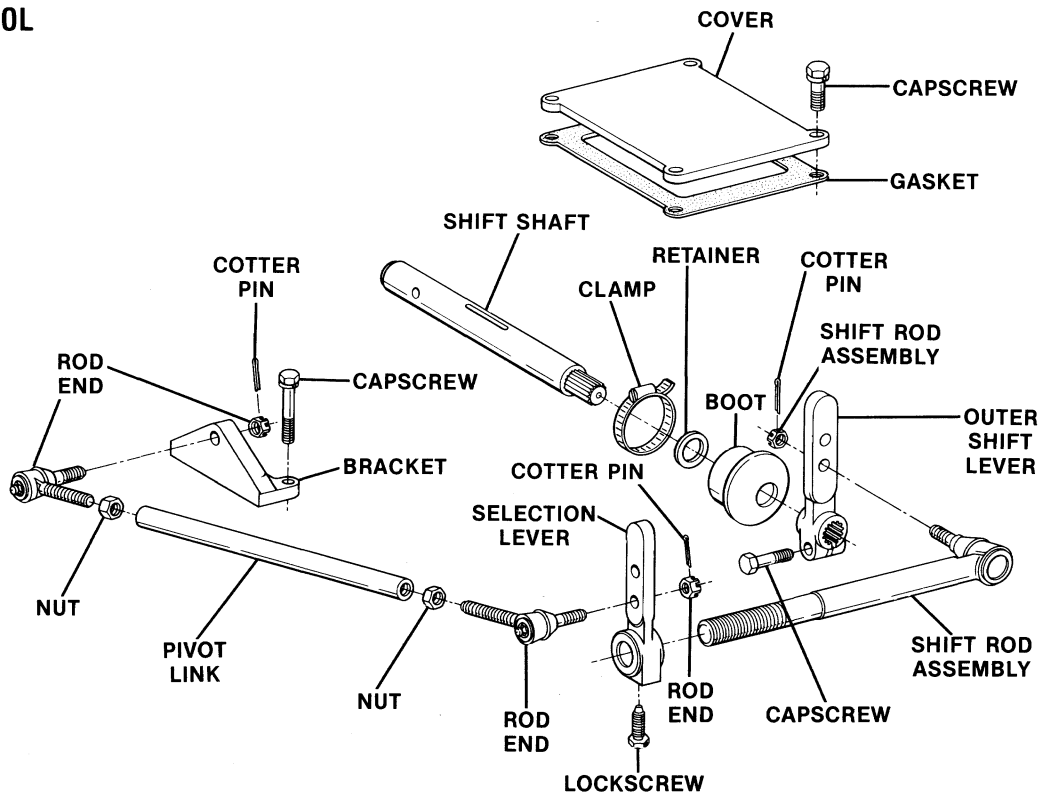

Cut 6727-5/85

# OPTIONS

## RELEASE YOKE ASSEMBLY (PUSH-TYPE)

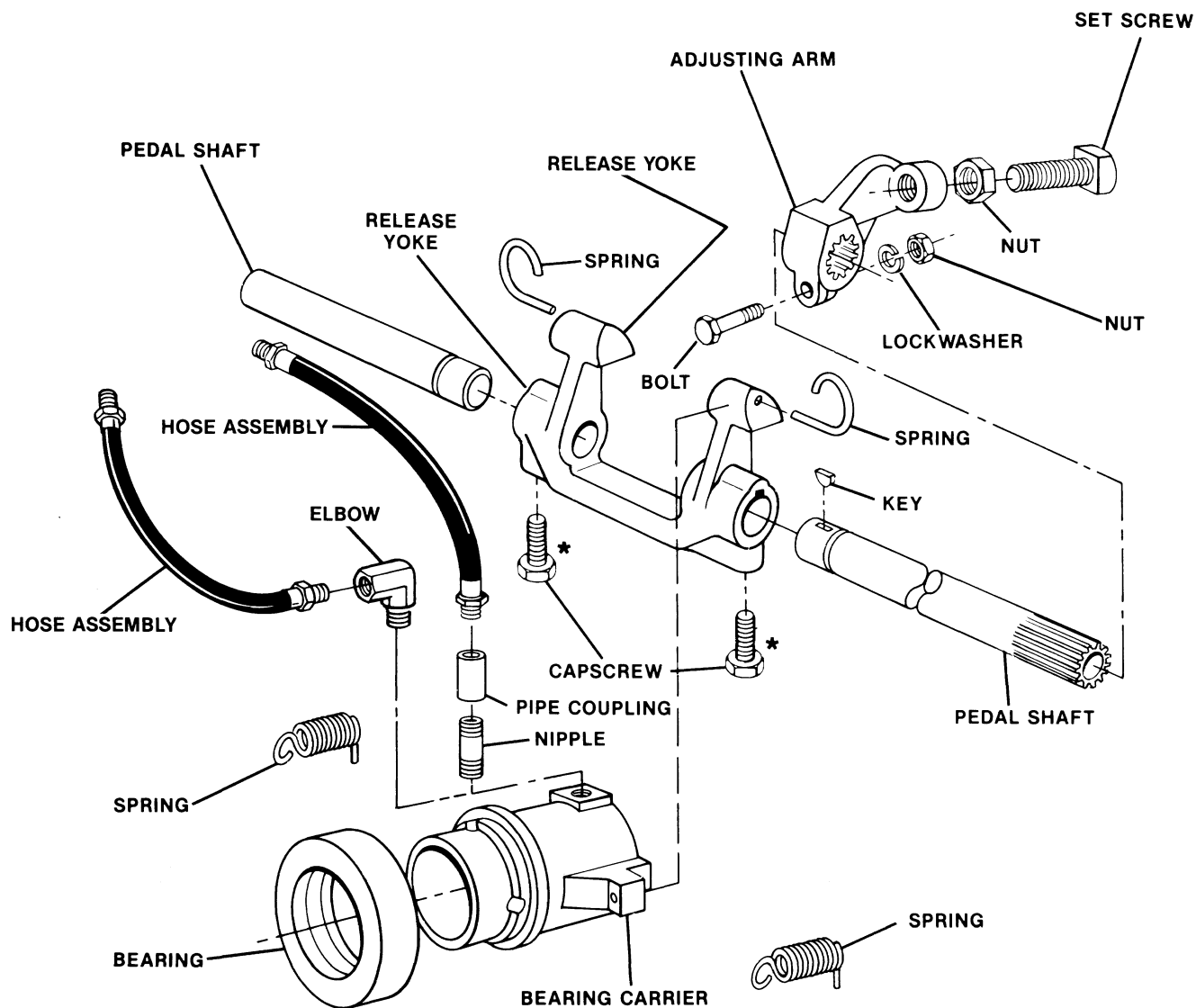

**\*NOTE:** Use Lockwire at these positions.





Copyright Eaton Corporation, 2012. Eaton hereby grant their customers, vendors, or distributors permission to freely copy, reproduce and/or distribute this document in printed format. It may be copied only in its entirety without any changes or modifications. THIS INFORMATION IS NOT INTENDED FOR SALE OR RESALE, AND THIS NOTICE MUST REMAIN ON ALL COPIES.

**Note:** Features and specifications listed in this document are subject to change without notice and represent the maximum capabilities of the software and products with all options installed. Although every attempt has been made to ensure the accuracy of information contained within, Eaton makes no representation about the completeness, correctness or accuracy and assumes no responsibility for any errors or omissions. Features and functionality may vary depending on selected options.

**For spec'ing or service assistance, call 1-800-826-HELP (4357) or visit [www.eaton.com/roadranger](http://www.eaton.com/roadranger). In Mexico, call 001-800-826-4357.**

Roadranger: Eaton and trusted partners providing the best products and services in the industry, ensuring more time on the road.

**Eaton Corporation**

Vehicle Group  
P.O. Box 4013  
Kalamazoo, MI 49003 USA  
800-826-HELP (4357)  
[www.eaton.com/roadranger](http://www.eaton.com/roadranger)

Printed in USA

For parts or service call us  
Pro Gear & Transmission, Inc.



**1 (877) 776-4600**

**(407) 872-1901**

**parts@eprogear.com**

**906 W. Gore St.**

**Orlando, FL 32805**

