

Fuller Mid Range Transmissions TRSM0140

October 2007



Powering Business Worldwide

BACKED BY

Roadranger

SUPPORT

For parts or service call us
Pro Gear & Transmission, Inc.



1 (877) 776-4600

(407) 872-1901

parts@eprogear.com

906 W. Gore St.

Orlando, FL 32805



TABLE OF CONTENTS

FOREWORD.....	2
MODEL DESIGNATIONS AND SPECIFICATIONS.....	3
LUBRICATION.....	4
OPERATION.....	6
POWER FLOW.....	7
TORQUE RECOMMENDATIONS.....	8
PREVENTIVE MAINTENANCE.....	10
PRECAUTIONS	
DISASSEMBLY.....	12
INSPECTION.....	12
REASSEMBLY.....	14
DISASSEMBLY AND REASSEMBLY—SHIFTING CONTROLS	
GEARSHIFT LEVER HOUSING ASSEMBLY.....	15
SHIFT BAR HOUSING ASSEMBLY.....	18
REMOVAL—YOKE AND CLUTCH HOUSING.....	25
DISASSEMBLY—TRANSMISSION.....	27
REASSEMBLY—TRANSMISSION.....	37
INSTALLATION—CLUTCH HOUSING AND YOKE.....	50
INSTALLATION—SHIFTING CONTROLS	
SHIFT BAR HOUSING ASSEMBLY.....	51
GEARSHIFT LEVER HOUSING ASSEMBLY.....	52
OPTIONS.....	53

FOREWORD

This manual is designed to provide detailed information necessary to service and repair the Fuller® Transmission listed on the cover.

As outlined in the Table of Contents, the manual is divided into 3 main sections:

- a. Technical information and reference
- b. Removal, disassembly, reassembly and installation
- c. Options

The format of the manual is designed to be followed in its entirety if complete disassembly and reassembly of the transmission is necessary. But if only one component of the transmission needs to be repaired, refer to the Table of Contents for the page numbers showing that component. For example, if you need to work on the Shift Bar Housing, you will find instructions for removal, disassembly and reassembly on page 18. Instructions for installation are on page 51. Service Manuals, Illustrated Parts Lists, Drivers Instructions, and other forms of product

service information for these and other Fuller Transmissions are available upon request. A Technical Literature Order Form may be found in the back of this manual*. You may also obtain Service Bulletins, detailing information on product improvements, repair procedures and other service-related subjects by writing to the following address:

EATON CORPORATION
TRANSMISSION DIVISION
Technical Service Department
P.O. Box 4013
Kalamazoo, Michigan 49003
(616) 342-3344

***Note to Canadian Residents:**

Please do not use the order form in the back of this manual. A special Canadian Product Literature Order Form may be obtained by contacting the following:

EATON CORPORATION
TRANSMISSION DIVISION
P.O. Box 1368
Benton Harbor, MI 49022
(616) 342-3344

MODEL DESIGNATIONS AND SPECIFICATIONS

Nomenclature:

FS-6105

Letter Designations

Fuller®

Synchronized

Number Designations

Forward Speeds

Design Level

× 100 = Nominal torque Capacity

IMPORTANT: All Fuller Transmissions are identified by model and serial number. This information is stamped on the transmission identification tag and affixed to the case.

DO NOT REMOVE OR DESTROY THE TRANSMISSION IDENTIFICATION TAG.

Specifications:

Model	No. Speeds	Gear Ratios						Relative Speed PTO Gear to Input R.P.M.		Note 1 Length In. (mm)	Note 2 Weight Lbs (Kg.)	Note 3 Oil Capacity Pints (Liters)
		1st	2nd	3rd	4th	5th	Reverse	Right	Left			
FS-6105	5	7.22	3.89	2.22	1.29	1.00	7.22	479	479	20.56 750.8	346 157	19 9

See Chart Notes.

CHART NOTES:

1. Lengths measured from face of clutch housing to center line of yoke.
2. Weights include shift bar housing and end yoke, less clutch housing, tower assembly and clutch release parts. For more information on available clutch housings, refer to publication FUL-140 "Clutch Housing Chart." All weights are approximate.
3. Oil capacities are approximate, depending on inclination of engine and transmission. Always fill transmission with proper grade and type of lubricant to level of filler opening. See LUBRICATION.

LUBRICATION

Proper Lubrication... the Key to long transmission life

Proper lubrication procedures are the key to a good all-around maintenance program. If the oil is not doing its job, or if the oil level is ignored, all the maintenance procedures in the world are not going to keep the transmission running or assure long transmission life.

Fuller® Transmissions are designed so that the internal parts operate in a bath of oil circulated by the motion of gears and shafts.

Thus, all parts will be amply lubricated if these procedures are closely followed:

1. Maintain oil level. Inspect regularly.
2. Change oil regularly.
3. Use the correct grade and type of oil.
4. Buy from a reputable dealer.

Lubrication Change and Inspection	
HIGHWAY USE	
First 3,000 to 5,000 miles (4827 to 8045 Km)	Change transmission oil on new units.
Every 10,000 miles (16090 Km)	Inspect oil level. Check for leaks.
Every 50,000 miles (80,450 Km)	Change transmission oil.
OFF-HIGHWAY USE	
First 30 hours	Change transmission oil on new units.
Every 40 hours	Inspect oil level. Check for leaks.
Every 500 hours	Change transmission oil where severe dirt conditions exist.
Every 1,000 hours	Change transmission oil (Normal off-highway use).

Oil filter should be changed at each oil change on units equipped with optional external oil filter.

Recommended Lubricants		
Type	Grade (SAE)	Fahrenheit (Celsius) Ambient Temperature
Heavy Duty Engine Oil MIL-L2104B, C or D or API-SF or API-CD (Previous API designations acceptable)	50 40 30	Above 10°F (-12°C) Above 10°F (-12°C) Below 10°F (-12°C)
Mineral Gear Oil with rust and oxidation inhibitor API-GL-1	80 90W	Above 10°F (-12°C) Below 10°F (-12°C)

The use of mild EP gear oil or multi-purpose gear oil is not recommended, but if these gear oils are used, be sure to adhere to the following limitations:

Do not use mild EP gear oil or multi-purpose gear oil when operating temperatures are above 230°F (110°C). Many of these gear oils, particularly 85W140, break down above 230°F and coat seals, bearings and gears with deposits that may cause premature failures. If these deposits are observed (especially a coating on seal areas causing oil leakage), change to heavy duty engine oil or mineral gear oil to assure maximum component life and to maintain your warranty with Eaton. (Also see "Operating Temperatures".)

Additives and friction modifiers are not recommended for use in Fuller transmissions.

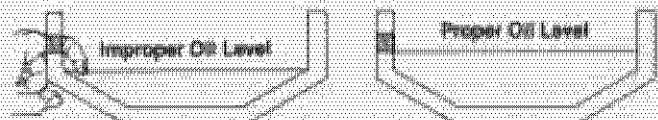

Proper Oil Level

Make sure oil is level with filter opening. Because you can reach oil with your finger does not mean oil is at proper level. **One inch of oil level is about one gallon of oil.**

Draining Oil

Drain transmission while oil is warm. To drain oil remove the drain plug at bottom of case. Clean the drain plug before re-installing.

Refilling

Clean case around filler plug and remove plug from side of case. Fill transmission to the level of the filler opening. If transmission has two filler openings, fill to level of both openings.

The exact amount of oil will depend on the transmission inclination and model. Do not over fill—this will cause oil to be forced out of the case through front bearing cover.

When adding oil, types and brands of oil should not be intermixed because of possible incompatibility.

LUBRICATION

Operating Temperatures —With Heavy Duty Engine Oil and Mineral Oil

The transmission should not be operated consistently at temperatures above 250°F (120°C). However, intermittent operating temperatures to 300°F (149°C) will not harm the transmission. Operating temperatures above 250°F increase the lubricant's rate of oxidation and shorten its effective life. When the average operating temperature is above 250°F, the transmission may require more frequent oil changes or external cooling.

The following conditions in any combination can cause operating temperatures of over 250°F: (1) operating consistently at slow speeds, (2) high ambient temperatures, (3) restricted air flow around transmission, (4) exhaust system too close to transmission, (5) high horsepower, overdrive operation.

External oil coolers are available to reduce operating temperatures when the above conditions are encountered.

Transmission Oil Coolers are:

Recommended

- With engines of 350 H.P. and above with overdrive transmissions

Required

- With engines 399 H.P. and above with overdrive transmissions and GCW's over 90,000 lbs.
- With engines 399 H.P. and above and 1400 Lbs.-Ft. or greater torque
- With engines 450 H.P. and above

— With EP or Multipurpose Gear Oil

Mild EP gear oil and multipurpose gear oil are not recommended when lubricant operating temperatures are above 230°F (110°). In addition, transmission oil coolers are not recommended with these gear oils since the oil cooler materials may be attacked by these gear oils. **The lower temperature limit and oil cooler restriction with these gear oils generally limit their success to milder applications.**

Proper Lubrication Levels as Related to Operating Angles

If the transmission operating angle is more than 12 degrees, improper lubrication can occur. The operating angle is the transmission mounting angle in the chassis plus the percent of upgrade (expressed in degrees).

The chart below illustrates the safe percent of upgrade on which the transmission can be used with various chassis mounting angles. For example: if you have a 4 degree transmission mounting angle, then 8 degrees (or 14 percent of grade) is equal to the limit of 12 degrees. If you have a 0 degree mounting angle, the transmission can be operated on a 12 degree (21 percent) grade.

Anytime the transmission operating angle of 12 degrees is exceeded for an extended period of time the transmission should be equipped with an oil pump or cooler kit to insure proper lubrication.

Note on the chart the effect low oil levels can have on safe operating angles. Allowing the oil level to fall ½" below the filler plug hole reduces the degree of grade by approximately 3 degrees (5.5 percent).

Proper Lubrication Levels are Essential!

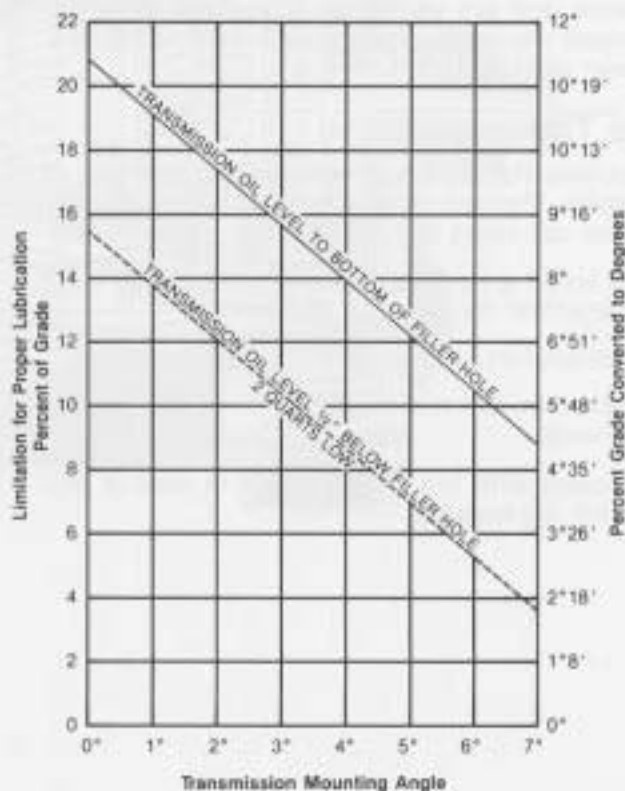

Dotted line showing "2 Quarts Low" is for reference only. Not recommended.

OPERATION

Gear Shift Lever Pattern and Shifting Instructions

Follow the simple 5-speed shift pattern . . .

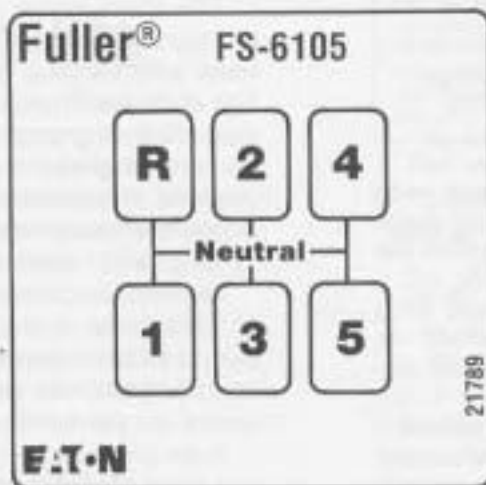

CL 9933A-9/88

General Information

FS-6105 transmissions have five forward speeds and one reverse, and are shifted as you would shift any synchronized manual transmission, following the simple 5-speed shift pattern.

Driving Tips

- Always use the clutch when making upshifts or downshifts. Premature synchronizer failure can result from not using the clutch.
- Always select a starting gear that will provide sufficient reduction for the load and terrain.
- Never downshift at too high of a road speed.
- Never slam or jerk the shift lever to complete gear engagement.
- Never coast with the transmission in neutral and the clutch dis-engaged.

POWER FLOW

The transmission must efficiently transfer the engine's power, in terms of torque, to the vehicle's rear wheels. Knowledge of what takes place in the transmission during torque transfer is essential when trouble-shooting and making repairs, becomes necessary.

1. Power (torque) from the engine is transferred to the input shaft and drive gear.
2. Torque is transferred to the countershaft drive gear.
3. Torque is delivered along countershaft to all countershaft gears.
4. Torque is transferred to "engaged" mainshaft gear. The cross section illustrates 1st speed gear position.
5. Internal clutching teeth of engaged mainshaft gear transfers torque to mainshaft through synchronizer assembly.
6. Mainshaft transfers torque directly to driveshaft through rear yoke.

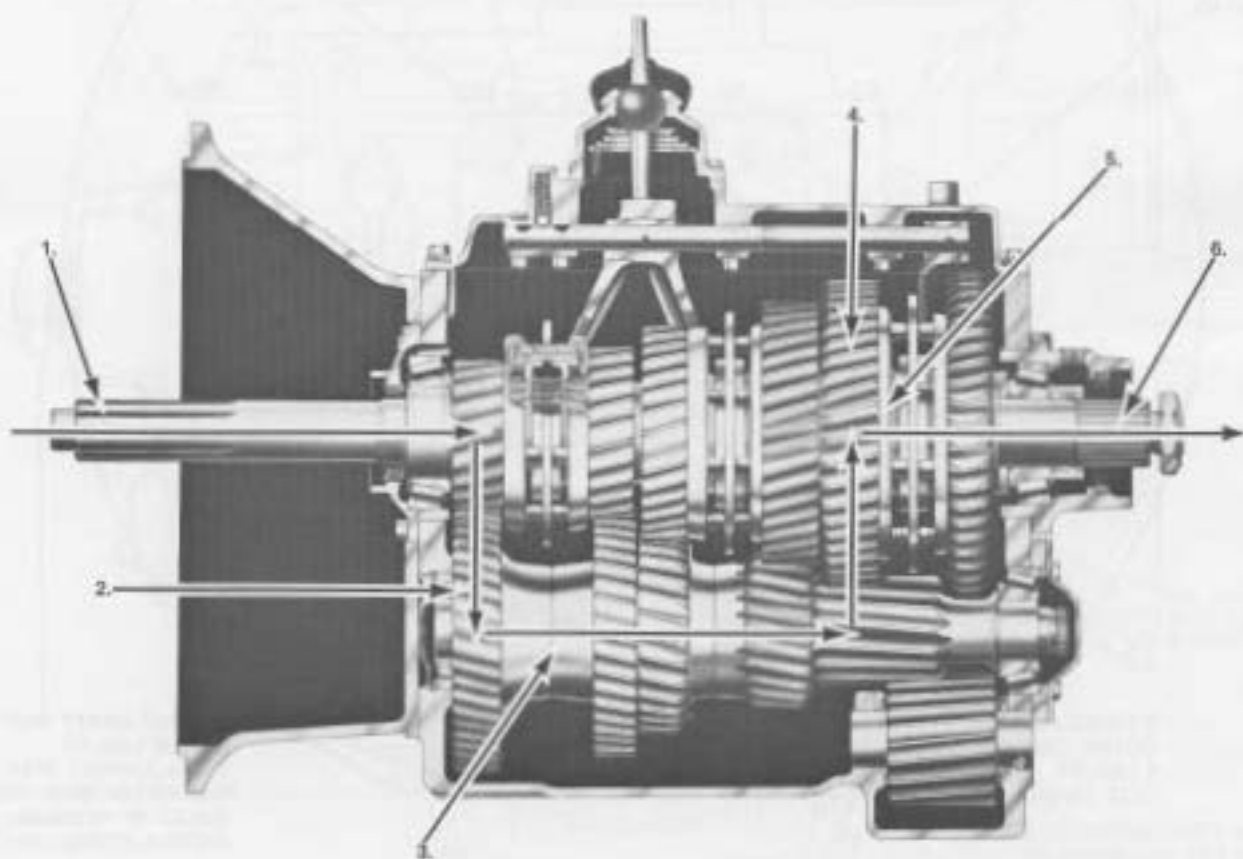

TORQUE RECOMMENDATIONS

Correct torque application is important to assure long transmission life. Over or under tightening of fasteners can result in a loose installation and, in many instances, can eventually cause damage to the transmission. Use a torque wrench to obtain recommended torque ratings. Do not torque capscrews dry.

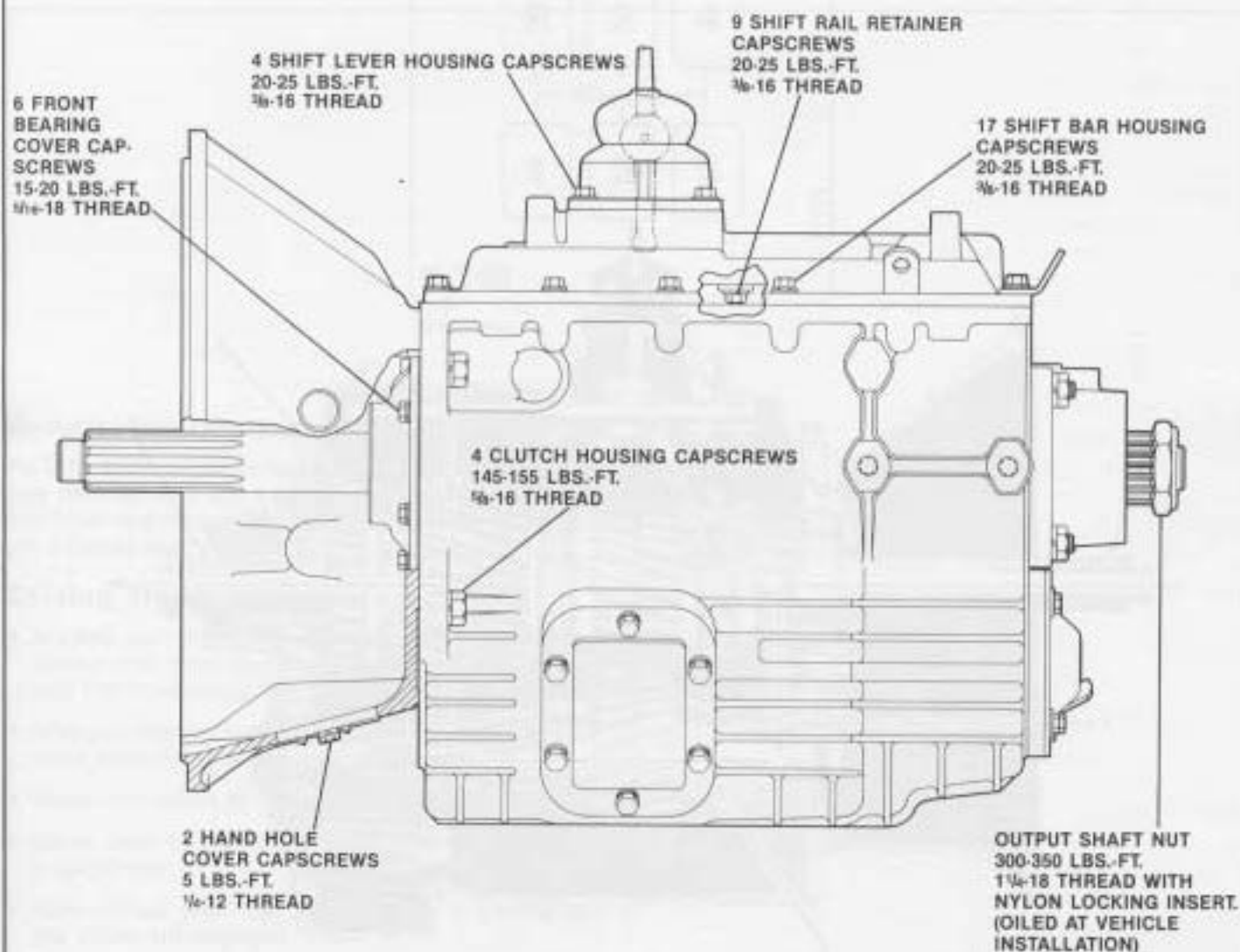

TORQUE RECOMMENDATIONS

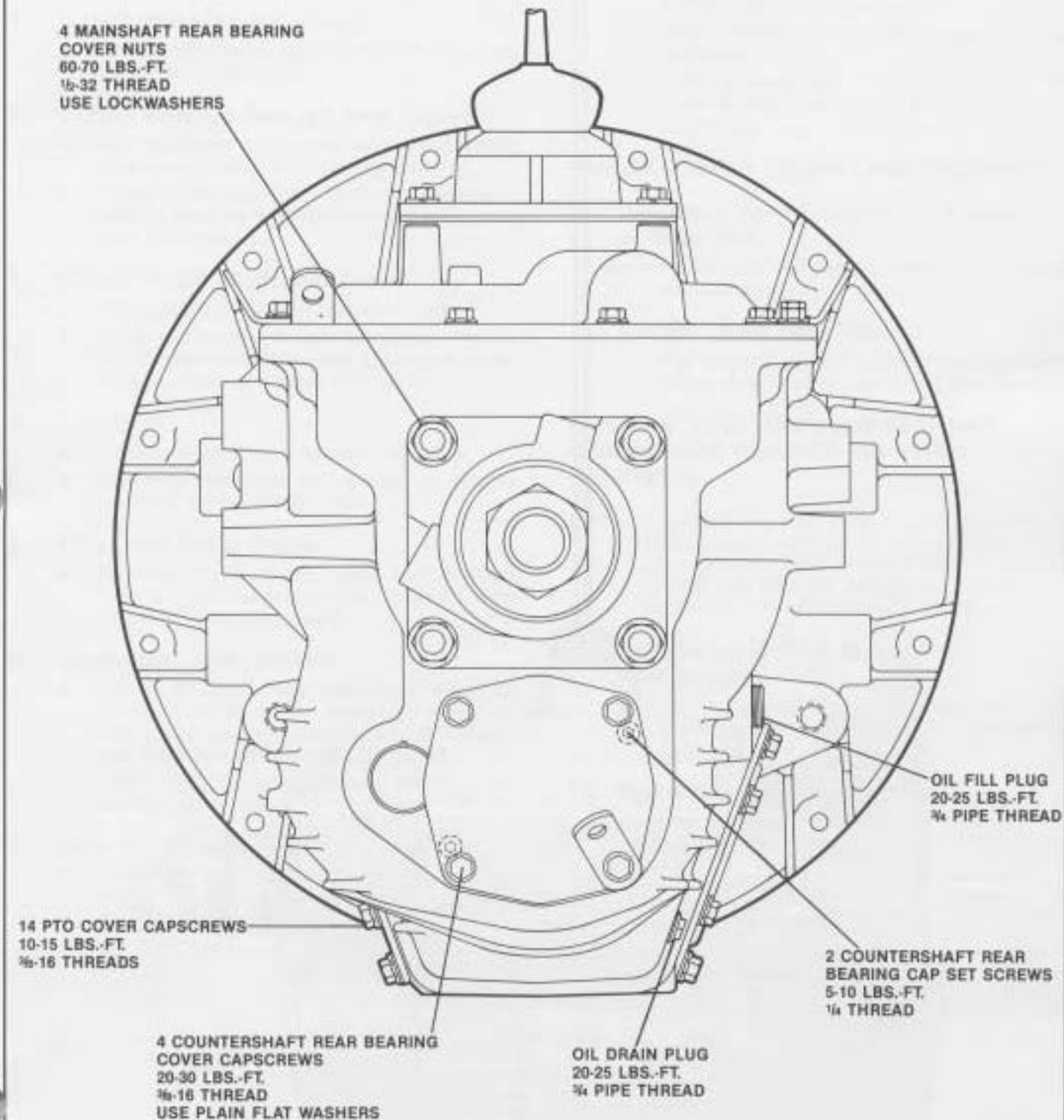

NOTE: APPLY LOCTITE 262 TO THREADS OF ALL CAPSCREWS BEFORE INSTALLING

PREVENTIVE MAINTENANCE

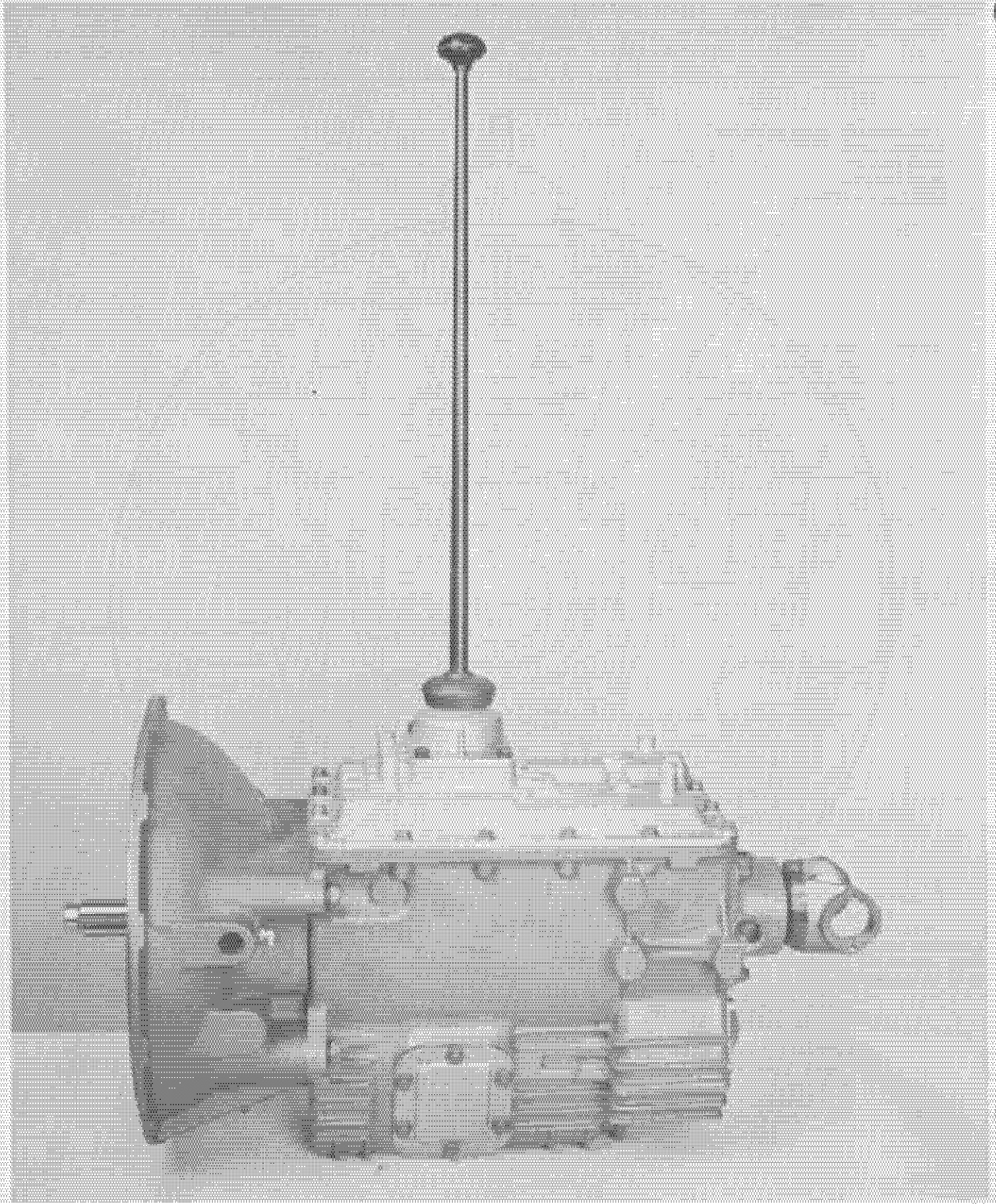

PREVENTIVE MAINTENANCE

PREVENTIVE MAINTENANCE CHECK CHART

CHECKS WITHOUT PARTIAL DISASSEMBLY OF CHASSIS OR CAB

1. **Clutch Housing Mounting**
 - a. Check all capscrews of clutch housing flange for looseness.
2. **Clutch Release Bearing (Not Shown)**
 - a. Remove hand hole cover and check radial and axial clearance in release bearing.
 - b. Check relative position of thrust surface of release bearing with thrust sleeve on push-type clutches.
3. **Clutch Pedal Shaft and Bores**
 - a. Pry upward on shafts to check wear.
 - b. If excessive movement is found, remove clutch release mechanism and check bushings in bores and wear on shafts.
4. **Lubricant**
 - a. Change at specified service intervals.
 - b. Use only the types and grades as recommended. See LUBRICATION.
5. **Filler and Drain Plugs**
 - a. Remove filler plug and check level of lubricant at specified intervals. Tighten filler and drain plugs securely.
6. **Capscrews and Gaskets**
 - a. Check all capscrews, especially those on PTO covers and rear bearing covers for looseness which would cause oil leakage. See TORQUE RECOMMENDATIONS.
 - b. Check PTO opening and rear bearing covers for oil leakage.
7. **Gear Shift Lever**
 - a. Check for looseness and free play in housing. If lever is loose in housing, proceed with Check No. 8.

8. **Gear Shift Lever Housing Assembly**
 - a. Remove the gear shift lever housing assembly from transmission.
 - b. Check tension spring and washer for set and wear.
 - c. Check bottom end of gear shift lever for wear of slots. Also check for wear of finger assembly.

CHECKS WITH DRIVE LINE DROPPED

9. **Universal Joint Companion Flange or Yoke Nut**
 - a. Check for tightness. Tighten to recommended torque.
10. **Output Shaft (Not Shown)**
 - a. Pry upward against output shaft to check radial clearance in mainshaft rear bearing.

CHECKS WITH UNIVERSAL JOINT COMPANION FLANGE OR YOKE REMOVED

NOTE: If necessary, use solvent and shop rag to clean sealing surface of companion flange or yoke. DO NOT USE CROCUS CLOTH, EMERY PAPER OR OTHER ABRASIVE MATERIALS THAT WILL MAR SURFACE FINISH.

11. **Splines on Output Shaft (Not Shown)**
 - a. Check for wear from movement and chucking action of the universal joint companion flange or yoke.
12. **Mainshaft Rear Bearing Cover**
 - a. Check oil seal for wear.

PRECAUTIONS

Disassembly

It is assumed in the detailed assembly instructions that the lubricant has been drained from transmission, the necessary linkage disconnected and the transmission has been removed from vehicle chassis. Removal of the gear shift lever housing assembly is included in the detailed instructions (Disassembly and Reassembly—Shifting Controls); however, this assembly must be detached from shift bar housing before transmission can be removed.

FOLLOW CLOSELY EACH PROCEDURE IN THE DETAILED INSTRUCTIONS, MAKING USE OF THE TEXT, ILLUSTRATIONS AND PHOTOGRAPHS PROVIDED.

- 1. BEARINGS**—Carefully wash and relubricate all reusable bearings as removed and protectively wrap until ready for use. Remove bearings planned to be reused with pullers designed for this purpose.
- 2. ASSEMBLIES**—When disassembling the various assemblies, such as the mainshaft, countershafts, and shift bar housing, lay all parts on a clean bench in the same sequence as removed. This procedure will simplify reassembly and reduce the possibility of losing parts.
- 3. SNAP RINGS**—Remove snap rings with pliers designed for this purpose. Snap rings removed in this manner can be reused, if they are not sprung or loose.
- 4. CLEANLINESS**—Provide a clean place to work. It is important that no dirt or foreign material enters the unit during repairs. Dirt is an abrasive and can damage bearings. It is always good practice to clean the outside of the unit before starting the planned disassembly.
- 5. WHEN USING TOOLS TO MOVE PARTS**—Always apply force to shafts, housings, etc. with restraint. Movement of some parts is restricted. Never apply force to the part being driven after it stops solidly. The use of soft hammers, bars and mauls for all disassembly work is recommended.

Inspection

Before reassembling the transmission, check each part carefully for abnormal or excessive wear and damage to determine reuse or replacement. When replacement is necessary, use only genuine Fuller Transmission parts to assure continued performance and extended life from your unit.

Since the cost of a new part is generally a small fraction of the total cost of downtime and labor, avoid reusing a questionable part which could lead to additional repairs and expense soon after initial reassembly. To aid in determining the reuse or replacement of any transmission part, consideration should also be given to the unit's history, mileage, application, etc.

Recommended inspection procedures are provided in the following checklist.

A. BEARINGS

1. Wash all bearings in clean solvent. Check balls, rollers and raceways for pitting, discoloration, and spalled areas. Replace bearings that are pitted, discolored, spalled, or damaged during disassembly.
2. Lubricate bearings that are not pitted, discolored, or spalled and check for axial and radial clearances.
Replace bearings with excessive clearances.
3. Check bearing fits. Bearing inner races should be tight to shaft; outer races slightly tight to slightly loose in case bore. If bearing spins freely in bore, however, case should be replaced.

B. GEARS

1. Check gear teeth for frosting and pitting. Frosting of gear tooth faces present no threat of transmission failure. Often in continued operation of the unit, frosted gears will "heal" and not progress to the pitting stage. In most cases, gears with light to moderate pitted teeth have considerable gear life remaining and can be reused, but gears with advanced stage pitting should be replaced.
2. Check for gears with clutching teeth abnormally worn, tapered, or reduced in length from clashing in shifting. Replace gears found in any of these conditions.

PRECAUTIONS

Inspection (cont'd.)

3. Check axial clearance of gears. Where excessive clearance is found, check gear snap ring, split washer, clutch hub, and gear hub for excessive wear.

C. SPLINES

1. Check splines on all shafts for abnormal wear. If sliding clutch gears, companion flange, or clutch hub have worn into the sides of the splines, replace the specific shaft affected.

D. WASHERS

1. Check surfaces of all washers. Washers scored or reduced in thickness should be replaced.

E. REVERSE IDLER GEAR ASSEMBLIES

1. Check for excessive wear from action of roller bearings.

F. GRAY IRON PARTS

1. Check all gray iron parts for cracks and breaks. Replace or repair parts found to be damaged. Heavy castings may be welded or brazed provided the cracks do not extend into bearing bores or bolting surfaces. When welding, however, never place the ground so as to allow current to pass through the transmission.

G. CLUTCH RELEASE PARTS

1. Check clutch release parts. Replace yokes worn at cam surfaces and bearing carrier worn at contact pads.
2. Check pedal shafts. Replace those worn at bushing surfaces.

H. SHIFT BAR HOUSING ASSEMBLY

1. Check for wear on shift yokes and finger assembly at pads and lever slot. Replace excessively worn parts.
2. Check yokes for correct alignment. Replace sprung yokes.
3. Check lockscrews in yoke assembly retainer plates. Tighten those found loose.

I. GEAR SHIFT LEVER HOUSING ASSEMBLY

1. Check spring tension on shift lever. Replace tension spring if lever moves too freely.
2. If housing is disassembled, check bottom end of gear shift lever and shift finger assembly for wear. Replace both parts if excessively worn.

J. BEARING COVERS

1. Check covers for wear from thrust of adjacent bearing. Replace covers damaged from thrust of bearing outer race.
2. Check bores of covers for wear. Replace those worn oversize.

K. OIL SEALS

1. Check oil seal in input shaft and rear bearing cover. If sealing action of lip has been destroyed, replace seal.

L. SYNCHRONIZER ASSEMBLY

1. Check synchronizer for burrs, uneven and excessive wear at contact surface, and metal particles.
2. Check blocker pins for excessive wear or looseness.
3. Check synchronizer contact surfaces on the synchronizer cups for wear.

PRECAUTIONS

Reassembly

Make sure that interiors of case and housings are clean. It is important that dirt and other foreign materials be kept out of the transmission during reassembly. Dirt is an abrasive and can damage polished surfaces of bearings and washers. Use certain precautions, as listed below, during reassembly.

- 1. GASKETS**—Use new gaskets throughout the transmission as it is being rebuilt. Make sure all gaskets are installed. An omission of any gasket can result in oil leakage or misalignment of bearing covers.
- 2. CAPSCREWS**—To prevent oil leakage and loosening, use Loctite 262 thread sealant on all capscrews. For torque ratings, see TORQUE RECOMMENDATIONS.
- 3. SHIMS**—Apply a light coat of Loctite 510 to both sides of shims before final installation to prevent leakage.
- 4. ASSEMBLY**—Refer to the illustrations provided in the detailed disassembly instructions as a guide to reassembly.
- 5. INITIAL LUBRICATION**—Coat all thrust washers, synchronizers, and bearings with transmission lubricant during reassembly to prevent damage during initial start up.
- 6. AXIAL CLEARANCES**—Maintain original axial clearances for mainshaft gears.
- 7. BEARINGS**—Use of a sleeve type driver that contacts the inner race of the bearing is recommended to prevent damage to the rollers and cage.
- 8. UNIVERSAL JOINT COMPANION FLANGE OR YOKE**—Pull the companion flange or yoke into place with the output shaft nut, using 300-350 lbs. ft. (407-475 Nm) of torque. Make sure the speedometer drive gear or a replacement spacer has been installed. Failure to properly torque the nut can result in damage to the mainshaft rear bearing.

IMPORTANT: REFER TO THE APPROPRIATE ILLUSTRATED PARTS LIST (SPECIFIED BY MODEL SERIES) TO ENSURE THAT PROPER PARTS ARE USED DURING REASSEMBLY OF THE TRANSMISSION.

DISASSEMBLY AND REASSEMBLY SHIFTING CONTROLS

GEARSHIFT LEVER HOUSING ASSEMBLY

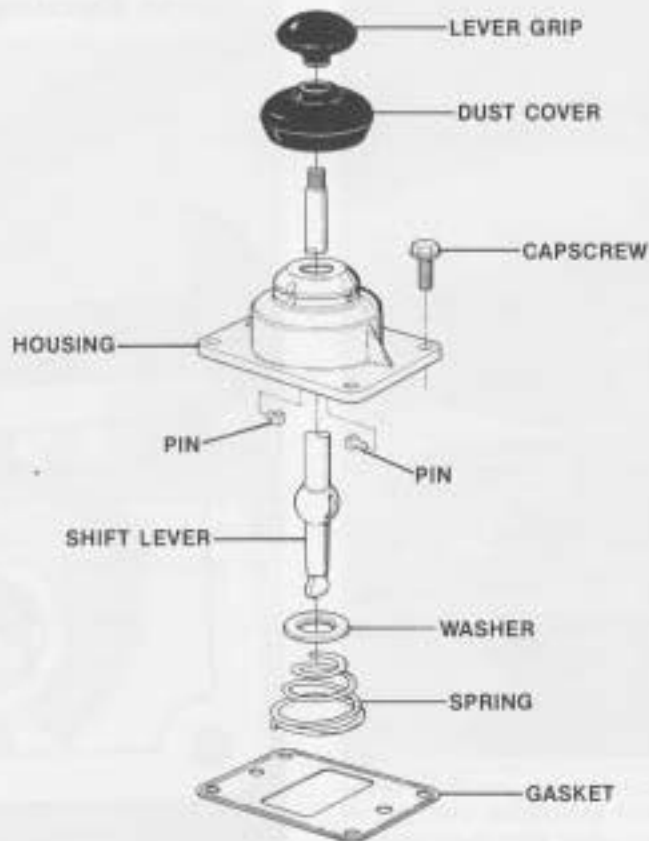

Cat 8299-5/16

A. Removal and Disassembly

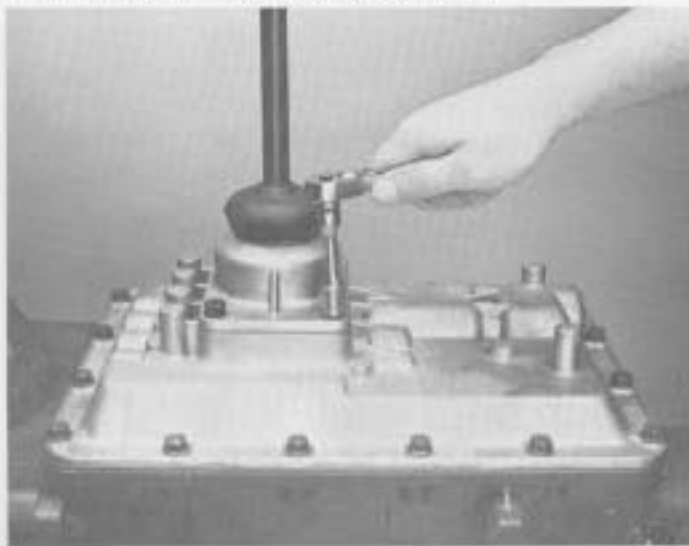

1. Turn out four capscrews and remove tower assembly and gasket from shift bar housing.

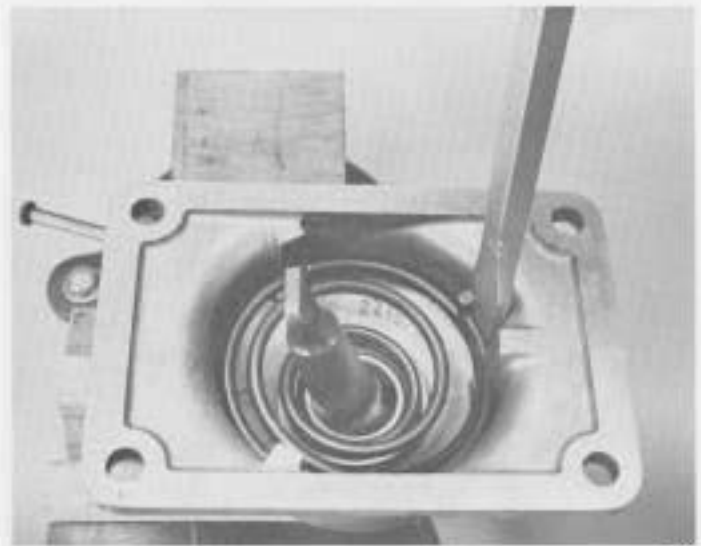

2. Remove shift lever grip and boot from shift lever, secure assembly in vise with bottom of housing up. Use a large screwdriver to twist between spring and housing, forcing spring from under lugs in housing. Do one coil at a time.

DISASSEMBLY AND REASSEMBLY SHIFTING CONTROLS

GEARSHIFT LEVER HOUSING ASSEMBLY (con't.)

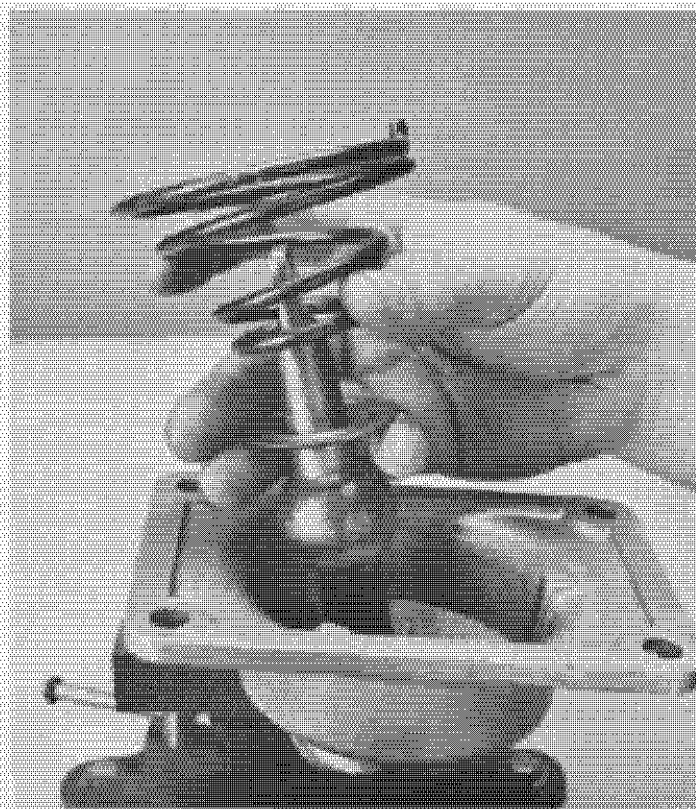

3. Remove tension spring, washer and gearshift lever from housing.

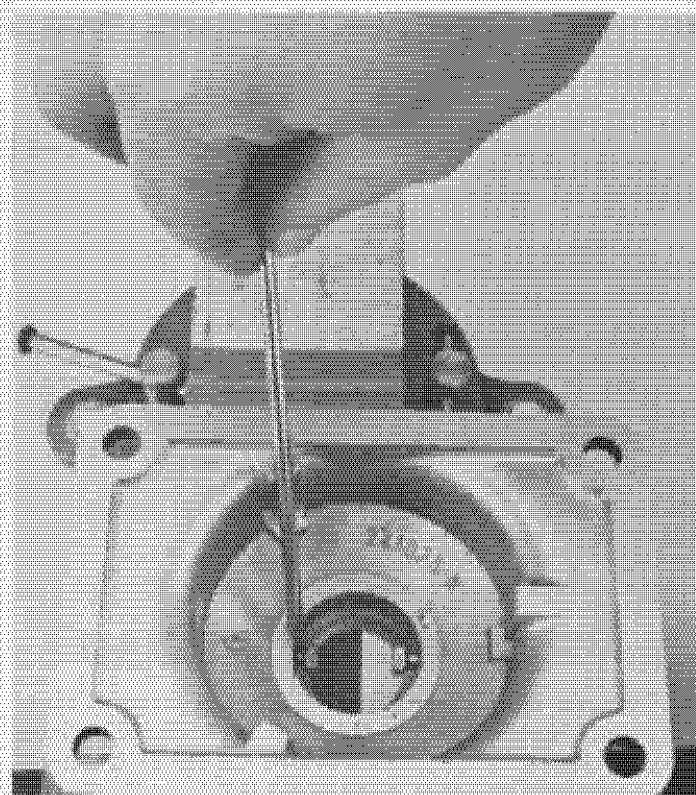

4. Remove spade pins from bore in housing.

B. Reassembly of Gearshift Lever Housing Assembly

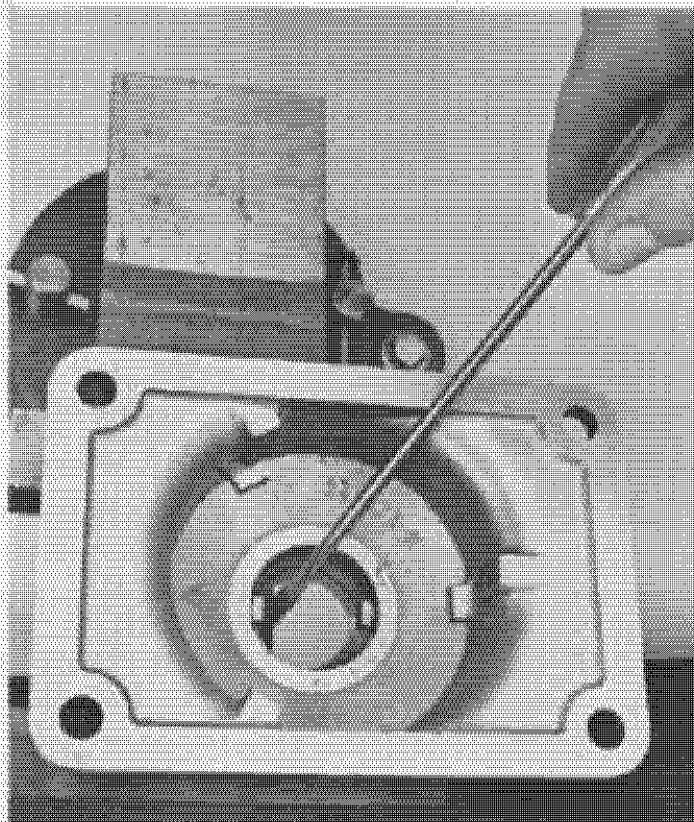

1. With gearshift lever housing secured in vise as during disassembly, install spade pins in bore of housing.

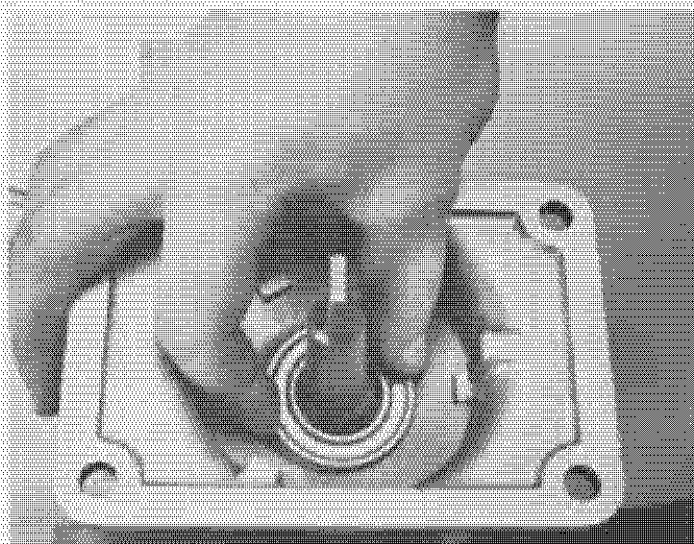

2. Position gearshift lever in housing with spade pins in lever ball slot and install tension spring washer over ball, dished side up.

DISASSEMBLY AND REASSEMBLY

SHIFTING CONTROLS

GEARSHIFT LEVER HOUSING ASSEMBLY (con't.)

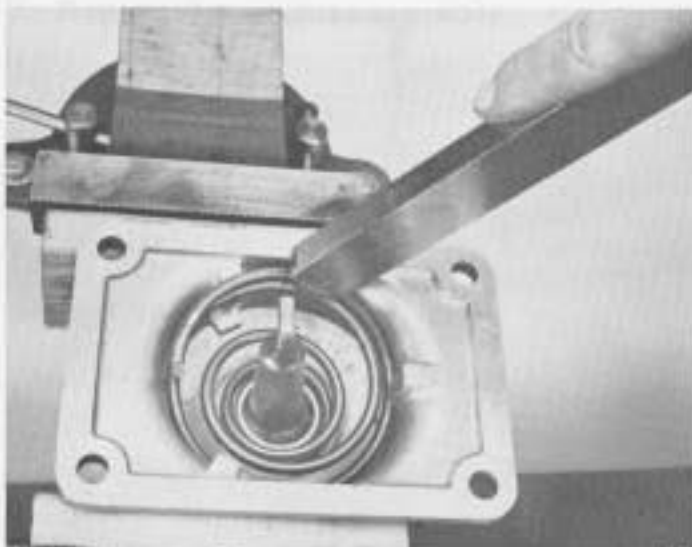

17-03

3. Install tension spring under lugs in housing, seating one coil at a time. Use of a spring driving tool is recommended.



17-04

4. Remove assembly from vise and install rubber boot over gearshift lever and against housing. Install shift lever grip.

DISASSEMBLY AND REASSEMBLY SHIFTING CONTROLS

SHIFT BAR HOUSING ASSEMBLY

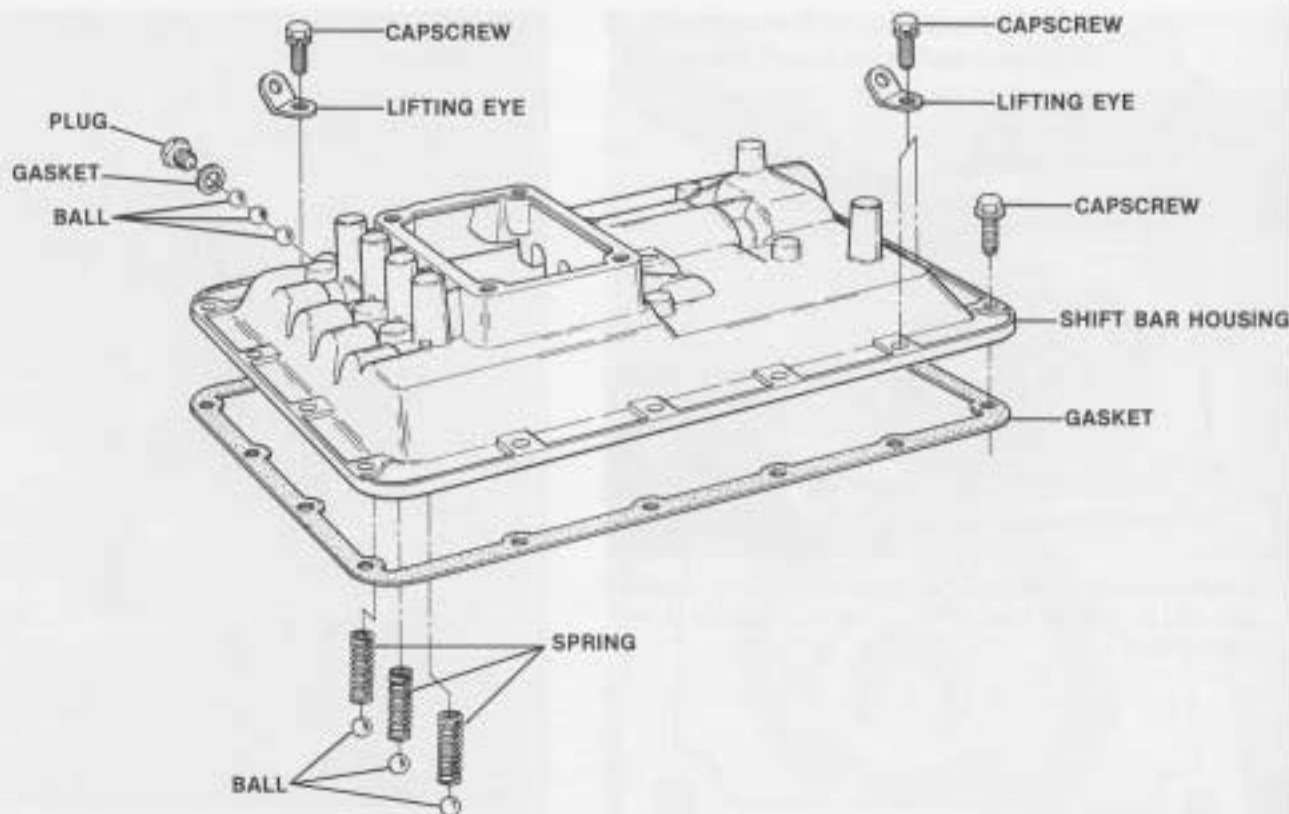

Cut 625A-1186

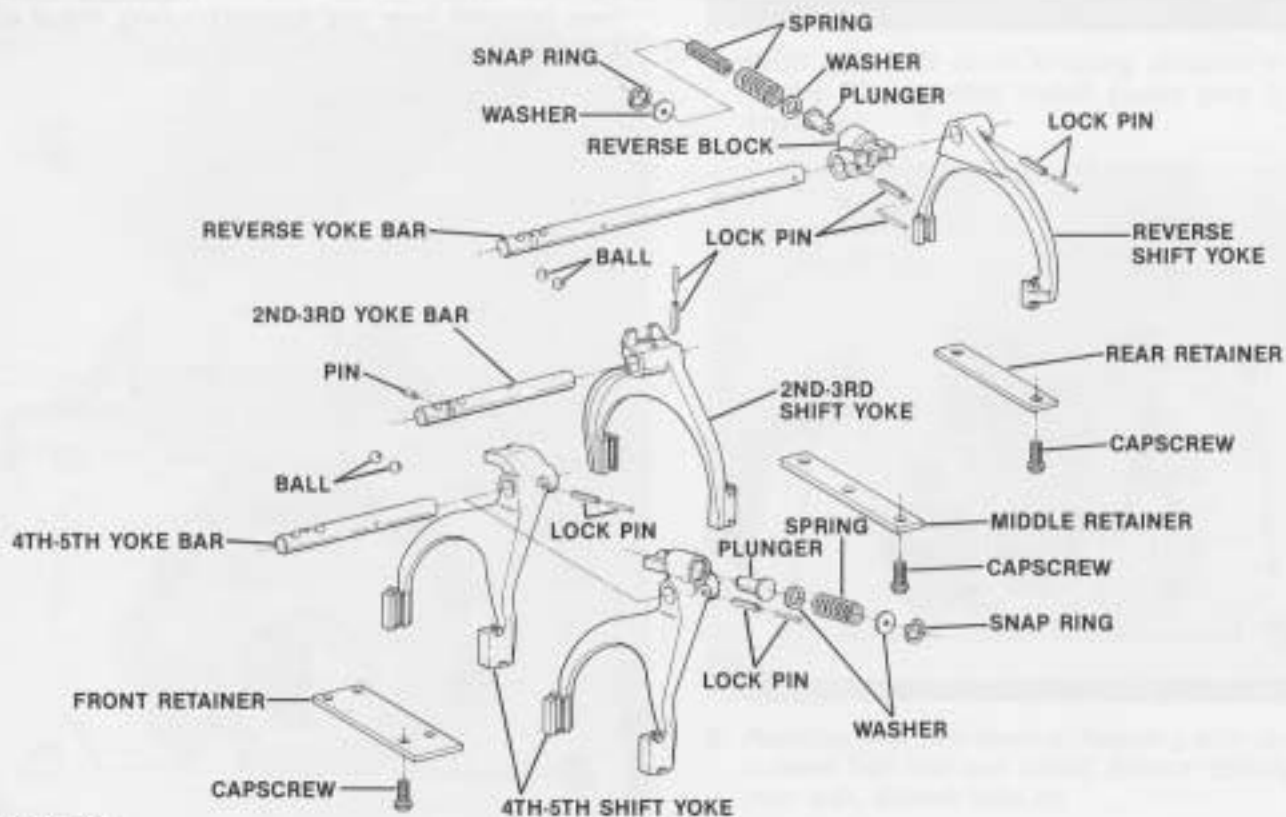

Cut 6226-1286

DISASSEMBLY AND REASSEMBLY SHIFTING CONTROLS

SHIFT BAR HOUSING ASSEMBLY (con't.)

A. Removal and Disassembly

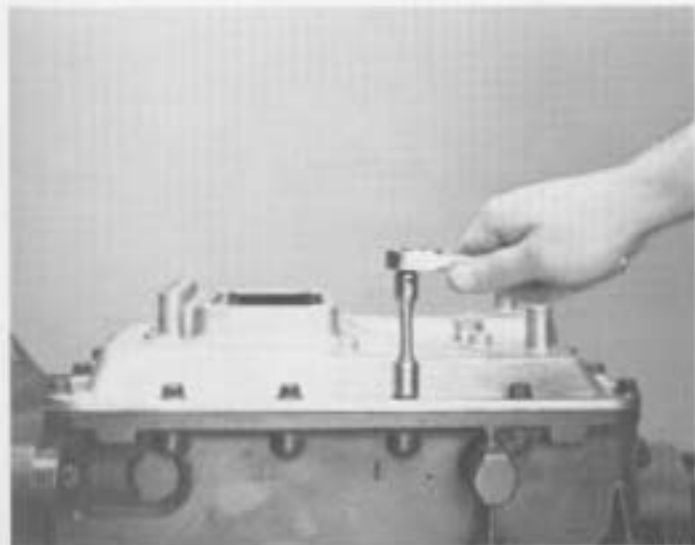

1. Shift transmission into neutral position, turn out cap screws, and lift shift bar housing and gasket from case.

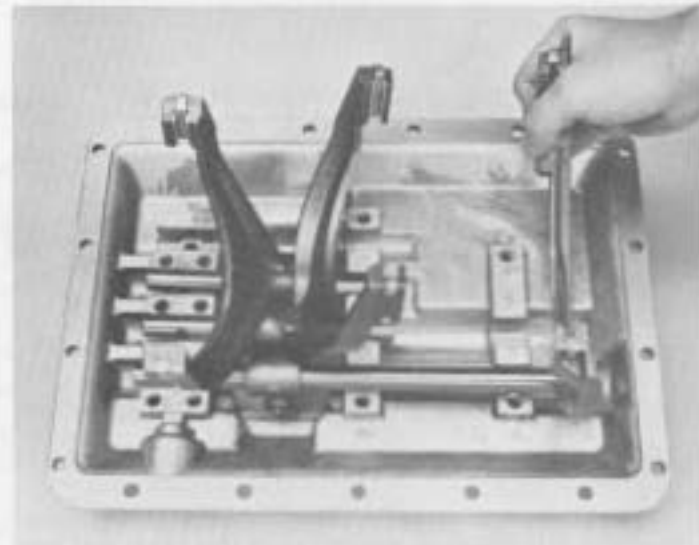

3. Remove 1st-reverse yoke assembly.

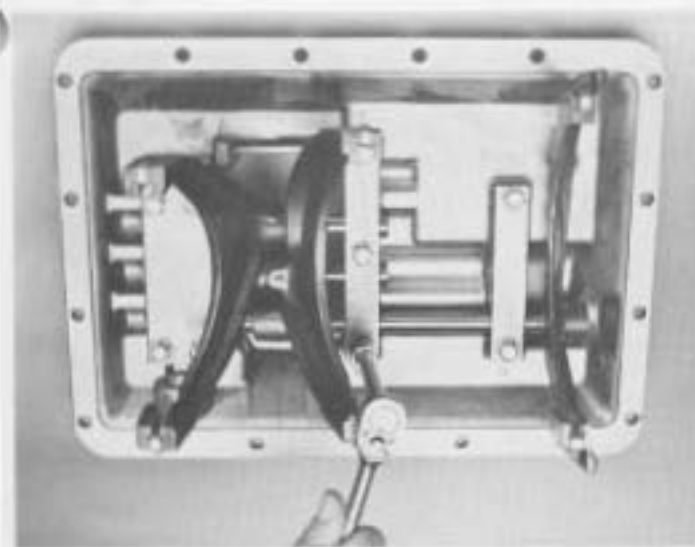

2. Lay shift bar housing on work bench as shown. Remove cap screws and retainers.

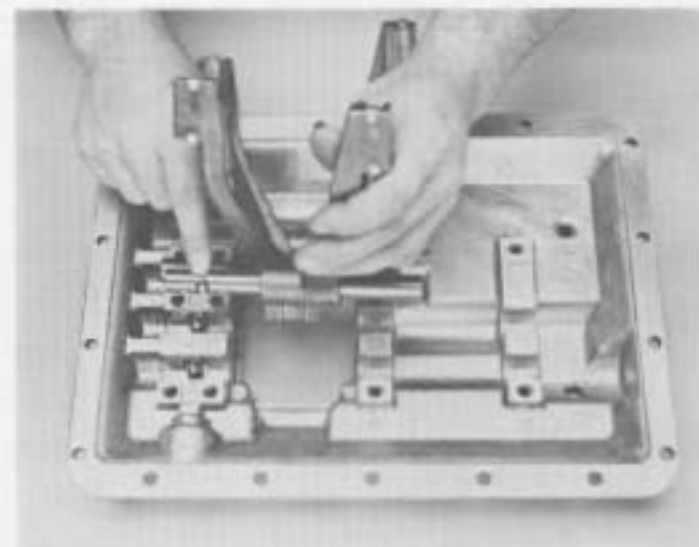

4. Remove 2nd-3rd yoke assembly and interlock pin.

DISASSEMBLY AND REASSEMBLY SHIFTING CONTROLS

SHIFT BAR HOUSING ASSEMBLY (con't.)

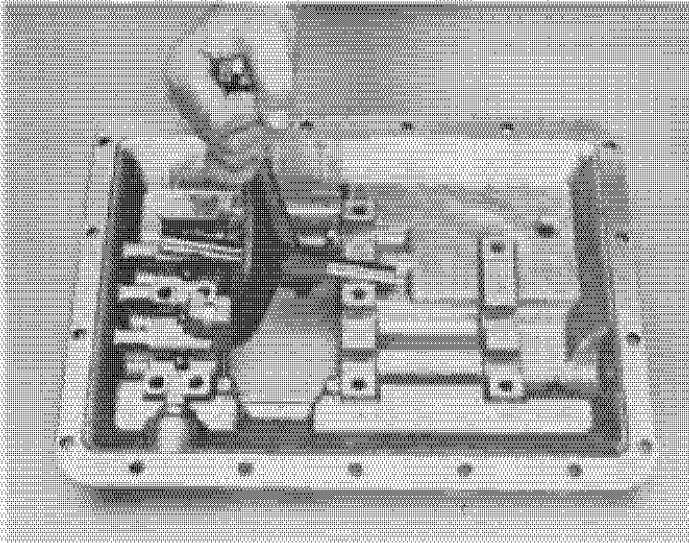

5. Remove 4th-5th yoke assembly. If the yoke pad inserts are to be replaced, remove worn pad from shift yoke, install new pad and bend tabs over top and bottom of yoke.

NOTE: If yoke replacement is required, yoke can be removed by driving the roll pin through the yoke and rail.

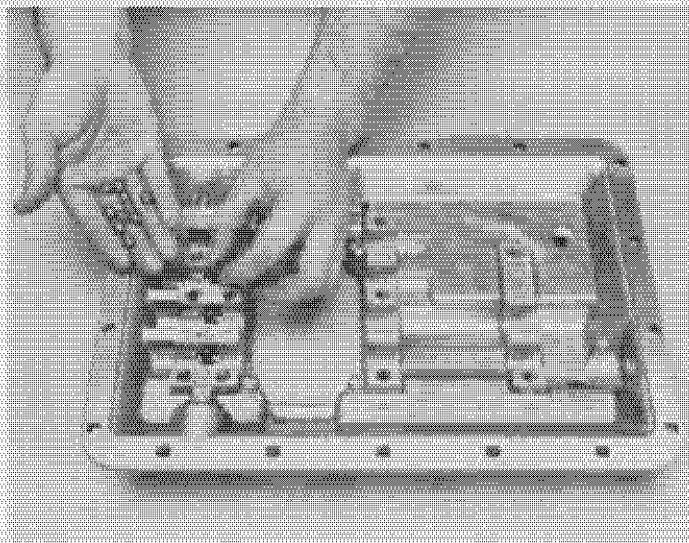

6. Remove interlock balls, detent balls, and springs.
NOTE: Remove interlock and detent balls before removing springs.

DISASSEMBLY AND REASSEMBLY SHIFTING CONTROLS

SHIFT BAR HOUSING ASSEMBLY (con't.)

B. Disassembly of Reverse Plunger

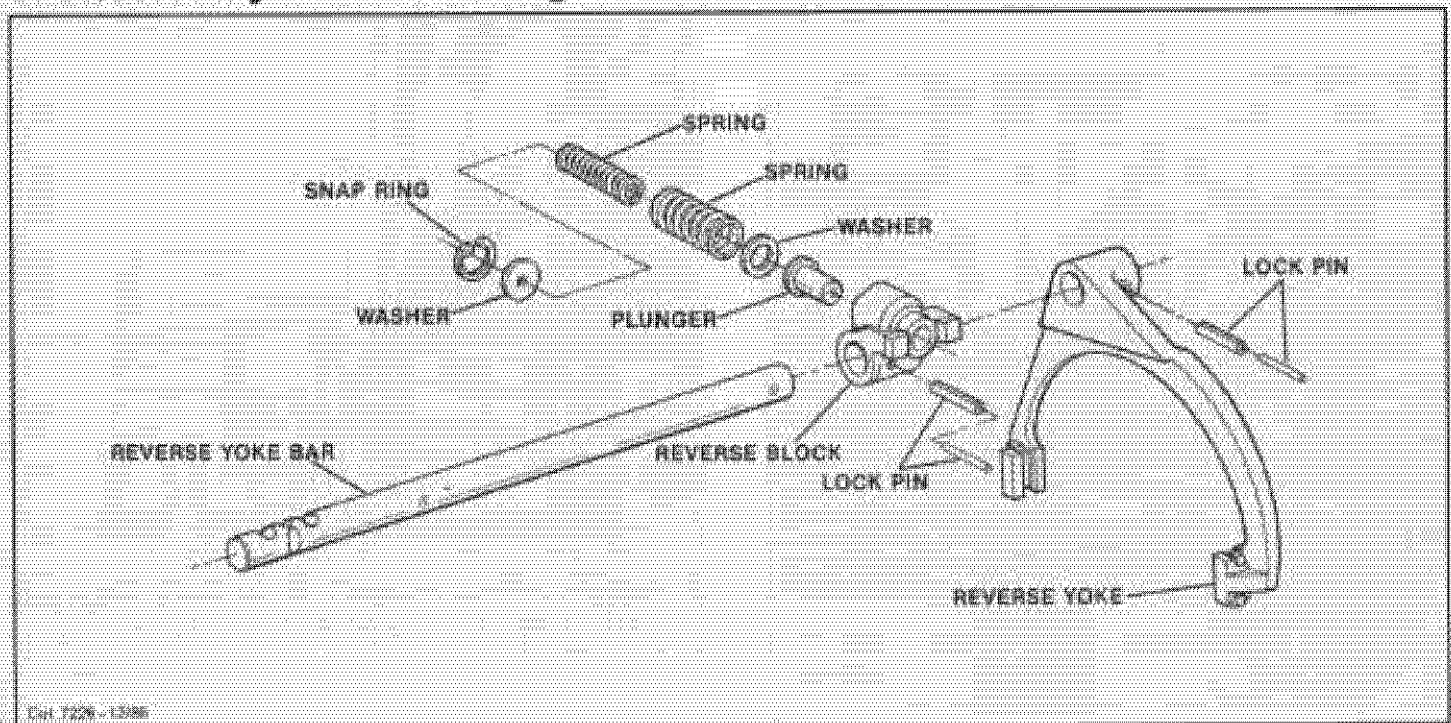

Ch. 7226 - 15196

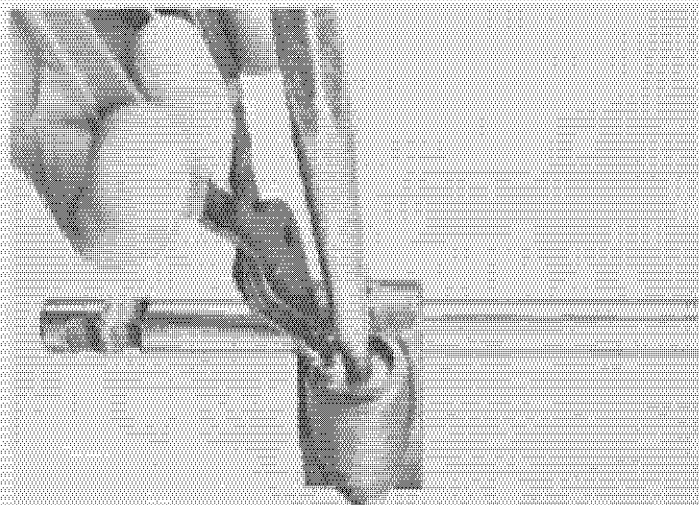

21-01

1. Depress reverse plunger springs and retainer as shown. Remove snap ring and spring retainer.
CAUTION: Snap ring and retainer are under spring pressure.

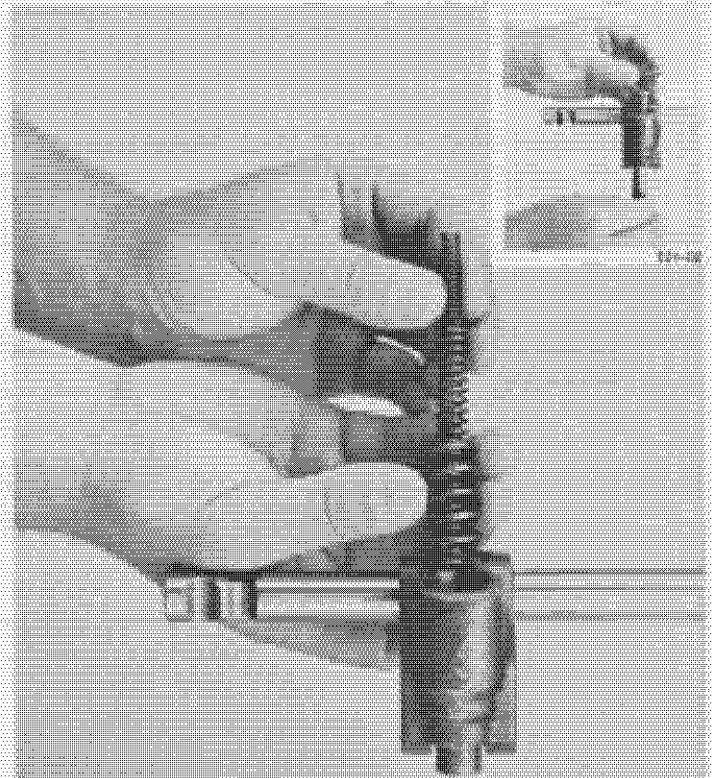

126-128

21-02

2. Remove reverse plunger springs.
NOTE: Some assemblies may only use two springs.
Remove washer and plunger (inset).

DISASSEMBLY AND REASSEMBLY SHIFTING CONTROLS

SHIFT BAR HOUSING ASSEMBLY (con't.)

C. Reassembly of Reverse Plunger Assembly

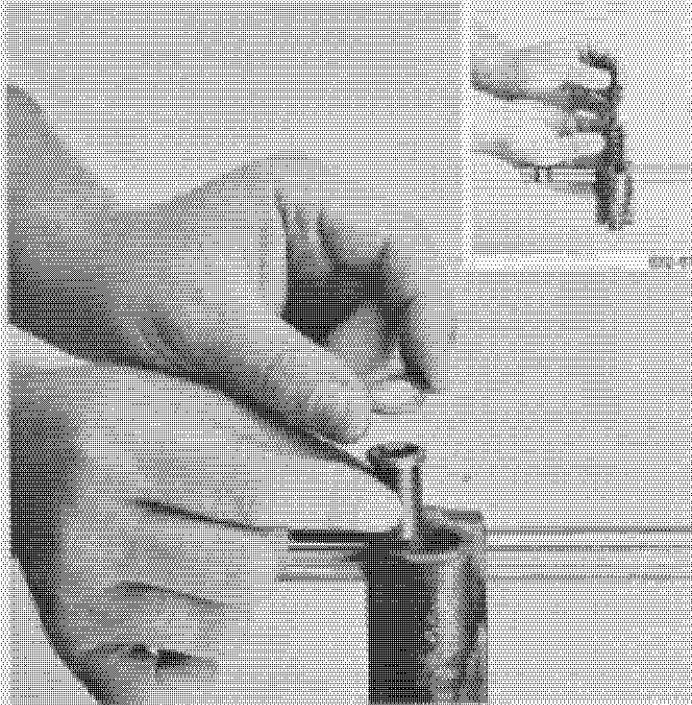

1. Install plunger and washer as shown and install reverse plunger springs (inset).

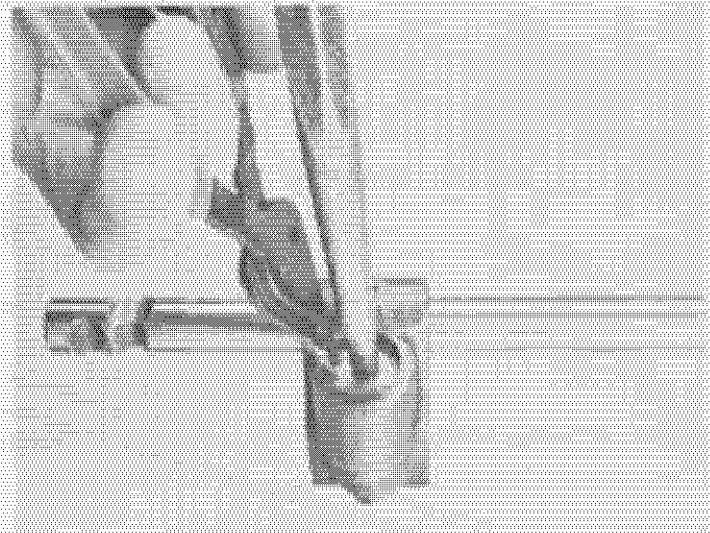

2. Depress reverse plunger retainer and springs and install snap ring in groove of shift block.

D. Reassembly of Shift Bar Housing

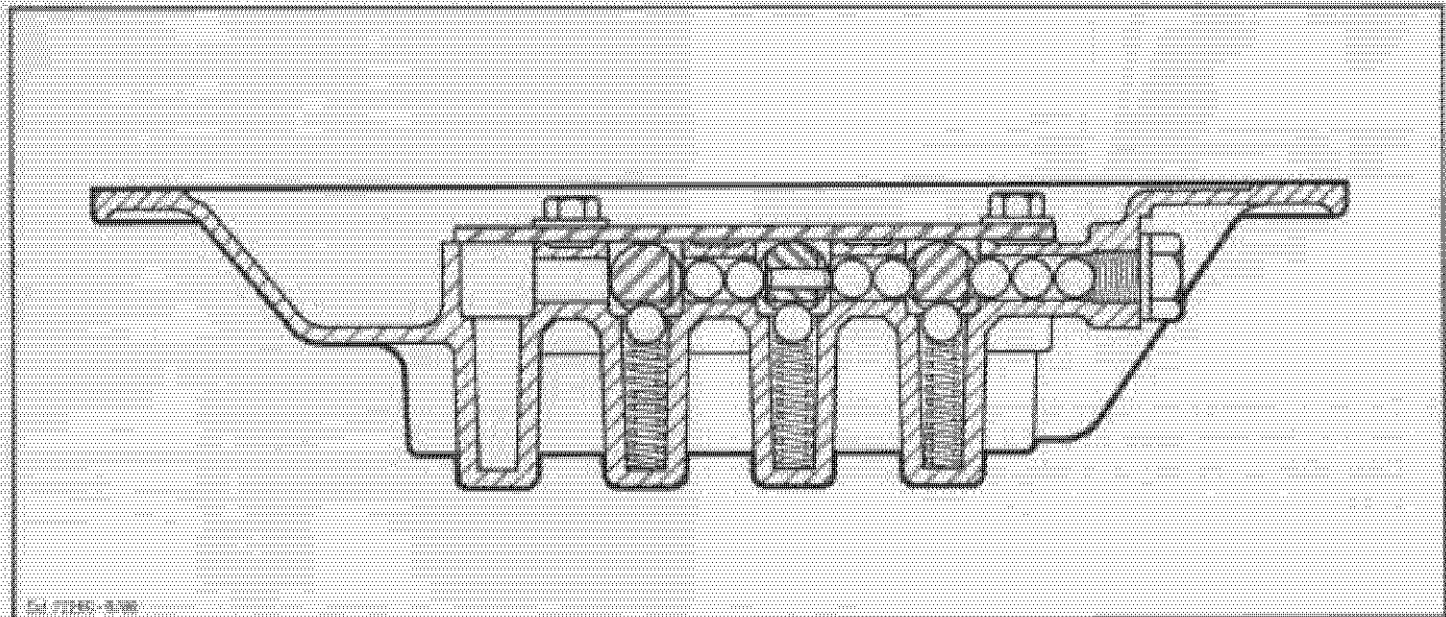

1. Install interlock balls, detent balls and springs in the following sequence; position (3) balls in the reverse light switch bore and install 1st-reverse detent spring and ball. Position (2) balls in adjacent cross bore and install 2nd and 3rd detent spring

and ball. Position (2) balls in adjacent cross bore and install 4th and 5th detent spring and ball.
NOTE: Balls and springs can be used interchangeably.

DISASSEMBLY AND REASSEMBLY SHIFTING CONTROLS

SHIFT BAR HOUSING ASSEMBLY (con't.)

NOTE: All yoke assemblies must be installed in the neutral position.

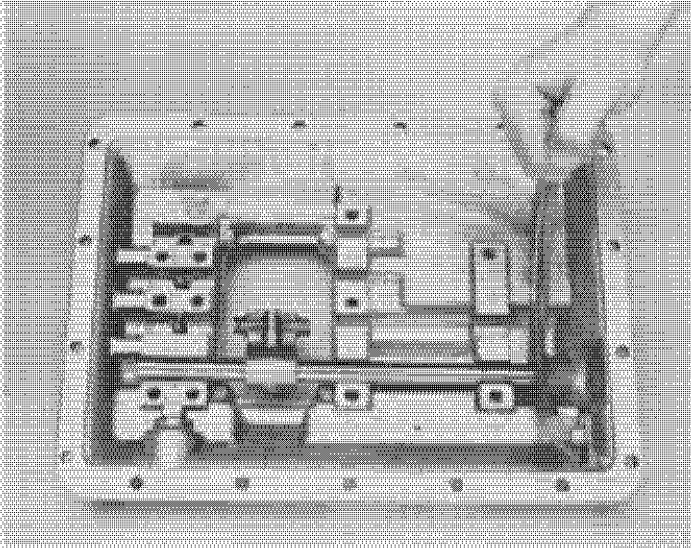

2. Position 1st-reverse yoke in housing assembly as shown.

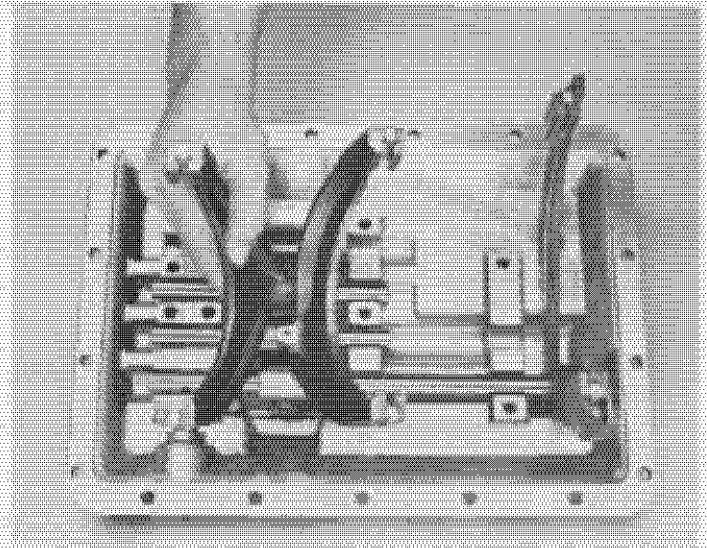

4. Position 4th-5th yoke assembly in housing as shown.

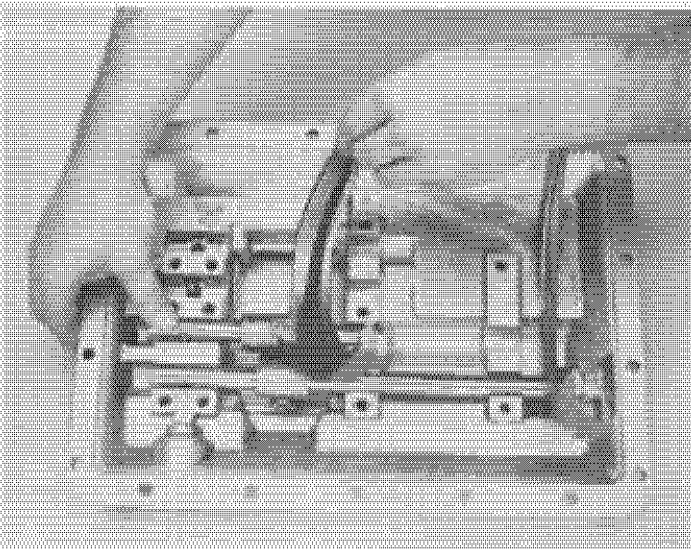

3. Install interlock pin in 2nd-3rd yoke assembly and position as shown.

DISASSEMBLY AND REASSEMBLY SHIFTING CONTROLS

SHIFT BAR HOUSING ASSEMBLY (con't.)

NOTE: The shift yoke retainer holes are not tapped on new shift bar housing. The capscrews that are used are "thread forming" and can be reused if the shift bar housing is replaced.

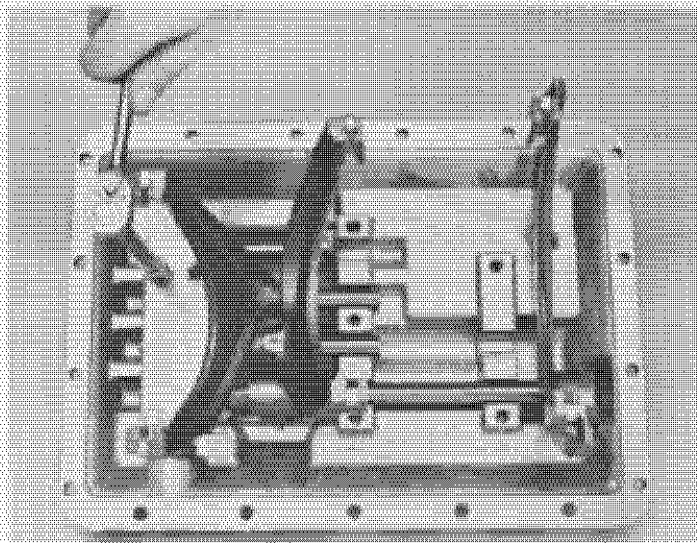

5. Position shift yokes as shown. Install front retainer over shift rails and install front two capscrews.

NOTE: It may be necessary to support rails in proper position while installing rail supports.

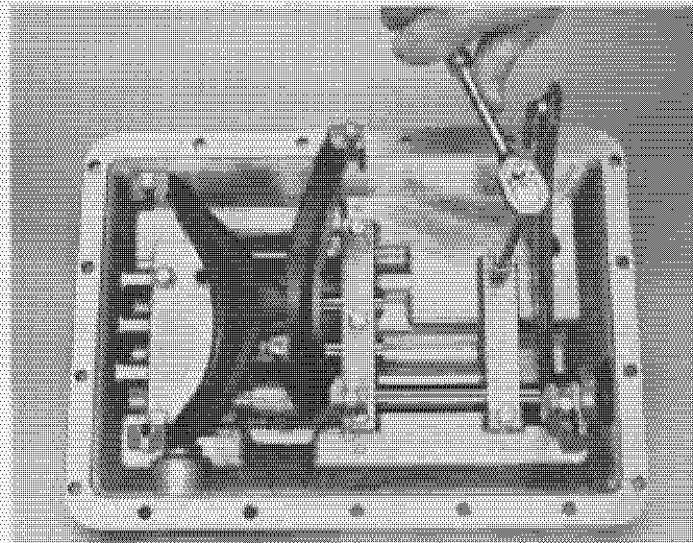

7. Position rear retainer over shift rails and install capscrews.

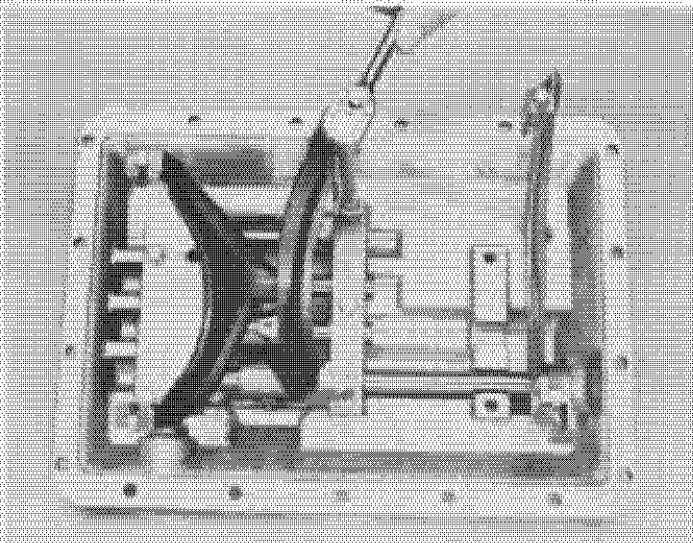

6. Position shift yokes as shown and install center retainer and capscrews.

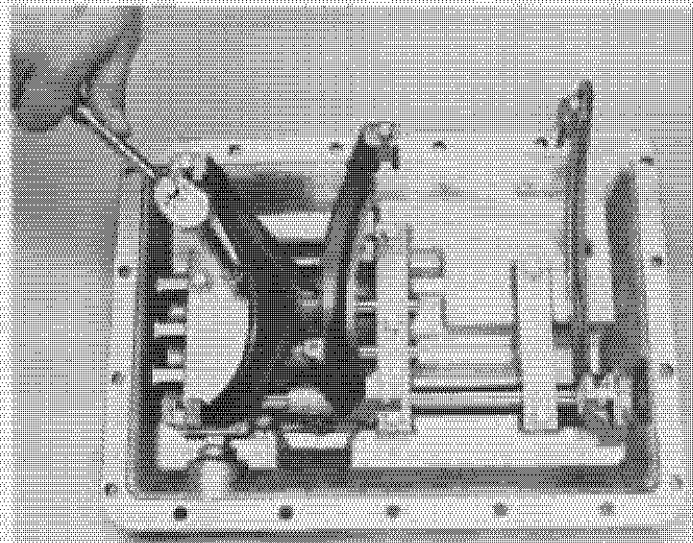

8. Install remaining 2 capscrews. Tighten all rail support capscrews to 20-25 lbs. ft. (27-34 Nm).

REMOVAL - YOKE AND CLUTCH HOUSING

Yoke and Clutch Housing

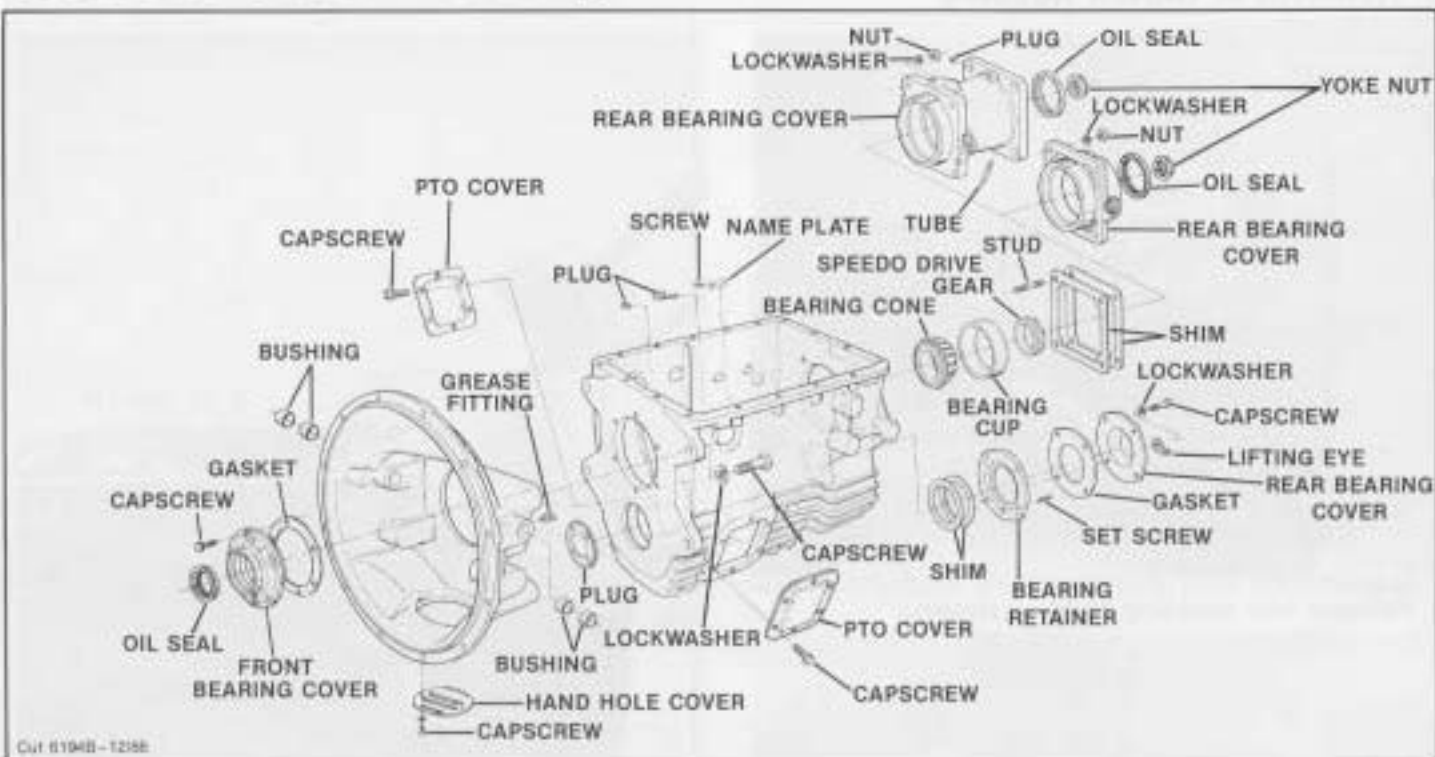

A. Removal of Yoke

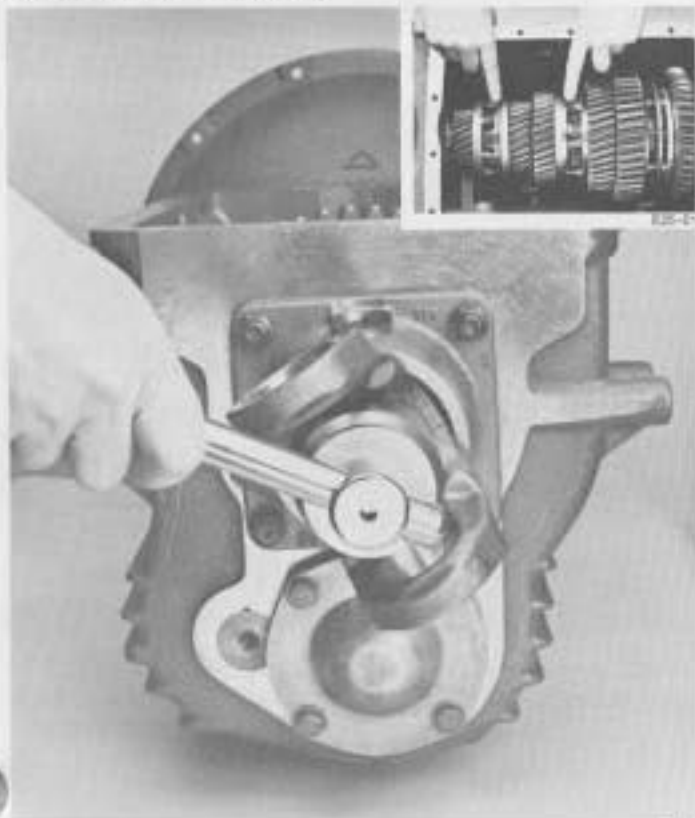

1. Lock the transmission by engaging two mainshaft gears (inset). Use a large breaker bar to turn the nut from the output shaft.



2. Remove yoke from output shaft.

REMOVAL - YOKE AND CLUTCH HOUSING

B. Removal of Clutch Housing

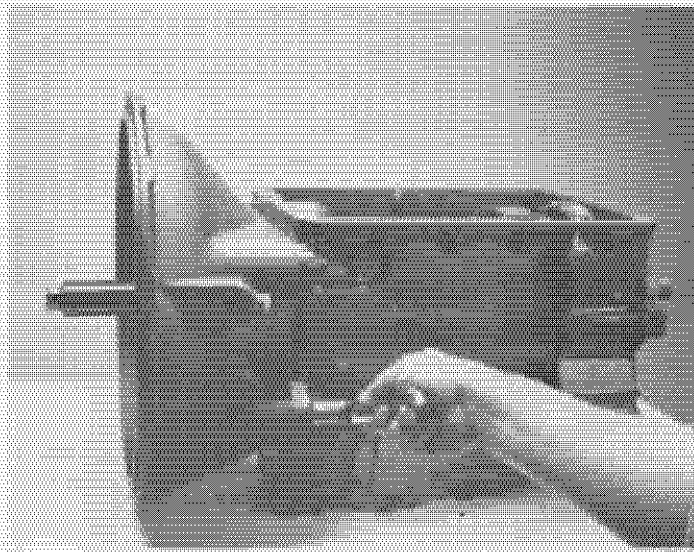

1. Remove four retaining bolts as shown.

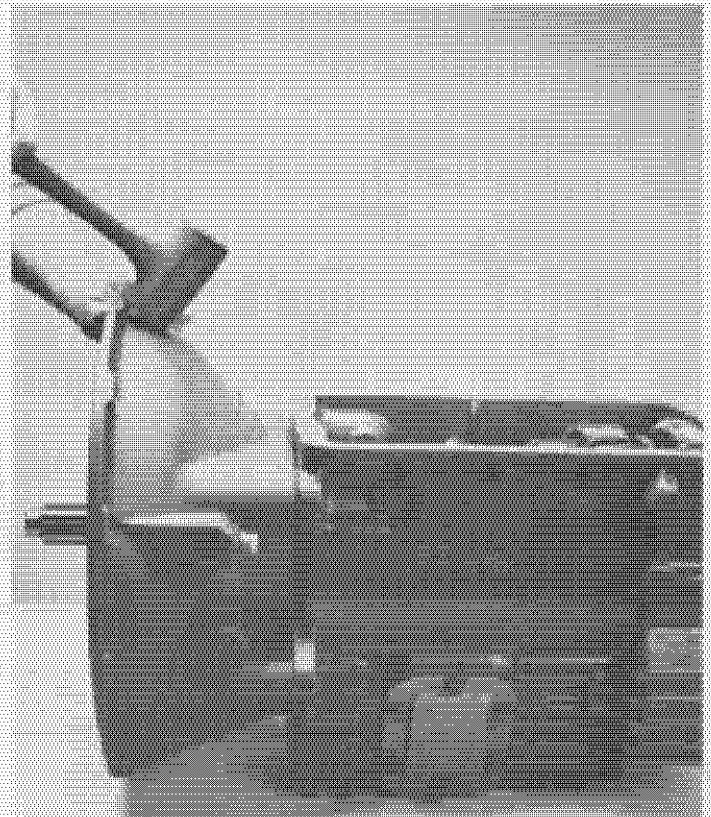

2. Jar clutch housing with rubber mallet and pull from transmission case.

DISASSEMBLY — TRANSMISSION

A. Removal & Disassembly of Input Shaft Assembly

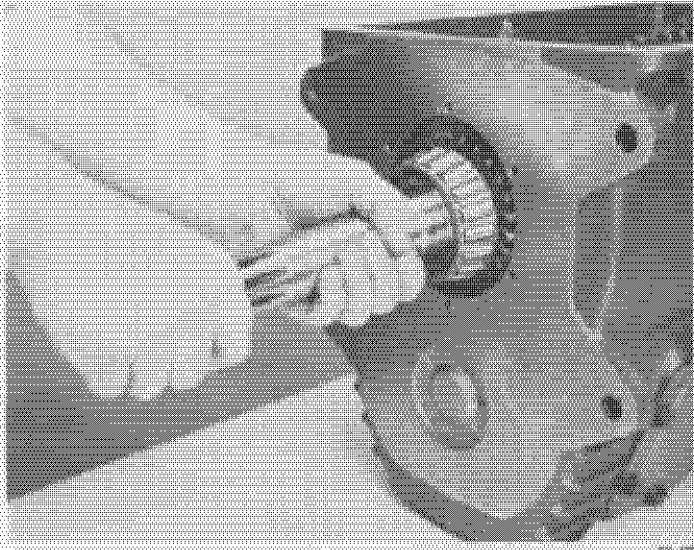
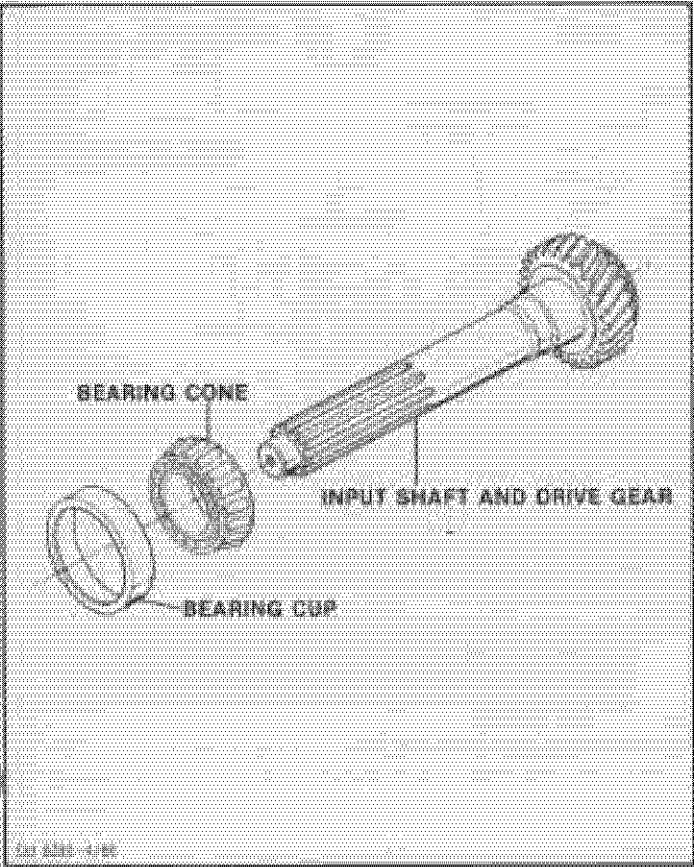

2. Remove input shaft assembly from transmission.

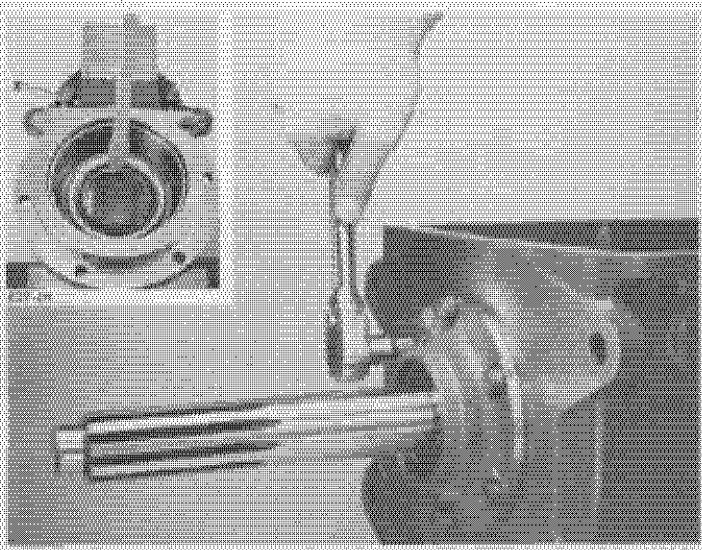

1. Turn out six capscrews, jar front bearing cover with a rubber mallet and remove. If necessary remove oil seal from cover (inset).

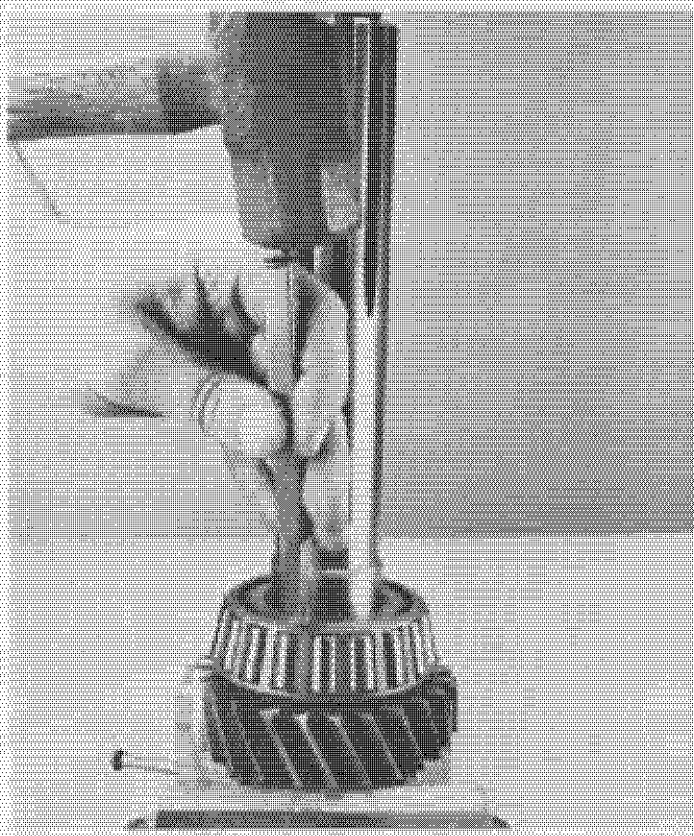

3. Using a chisel, remove bearing cage and rollers. Install bearing puller and remove bearing race from input shaft.

DISASSEMBLY — TRANSMISSION

B. Removal & Disassembly of Mainshaft

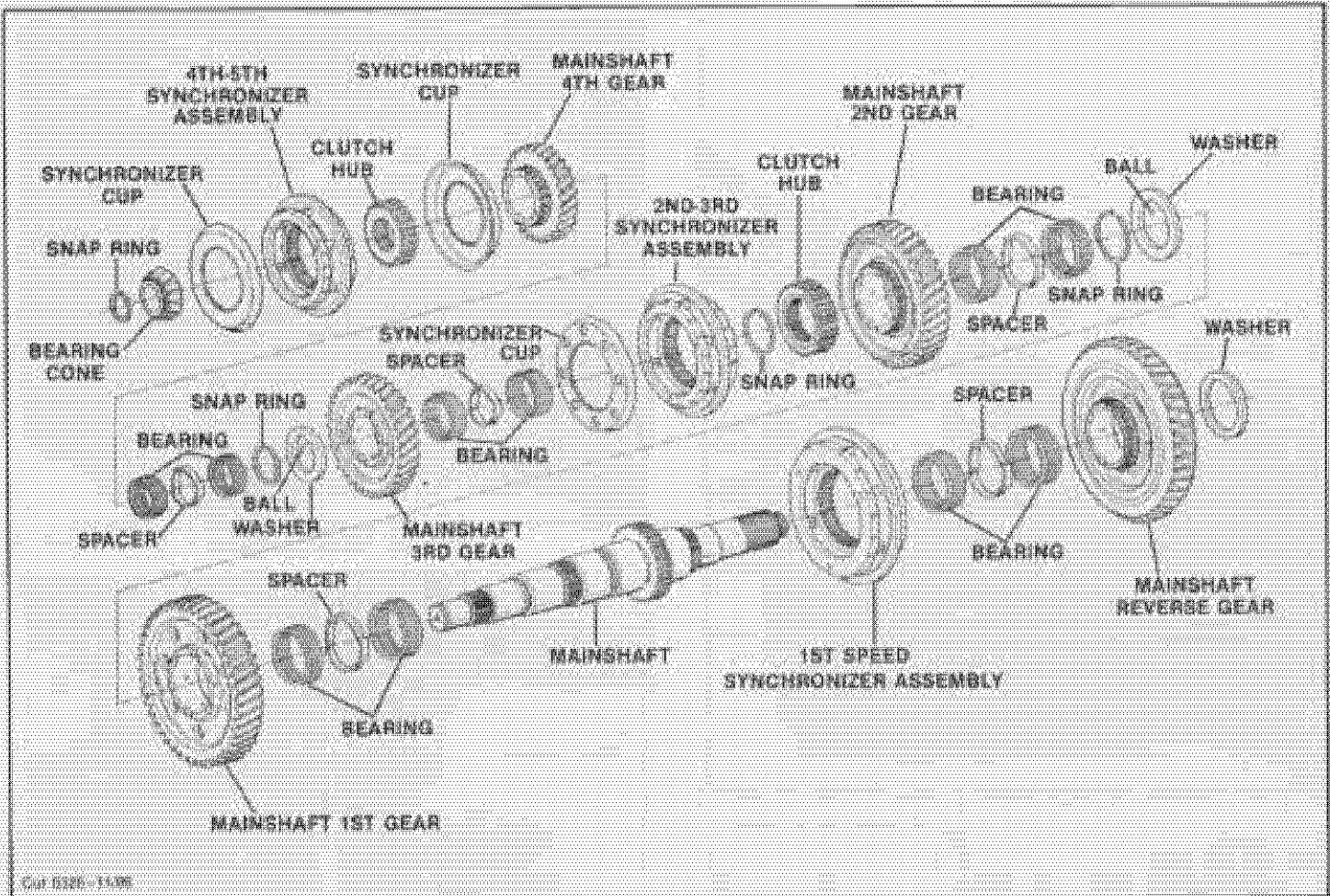

1. Turn out speedometer sleeve and remove speedometer driven gear.

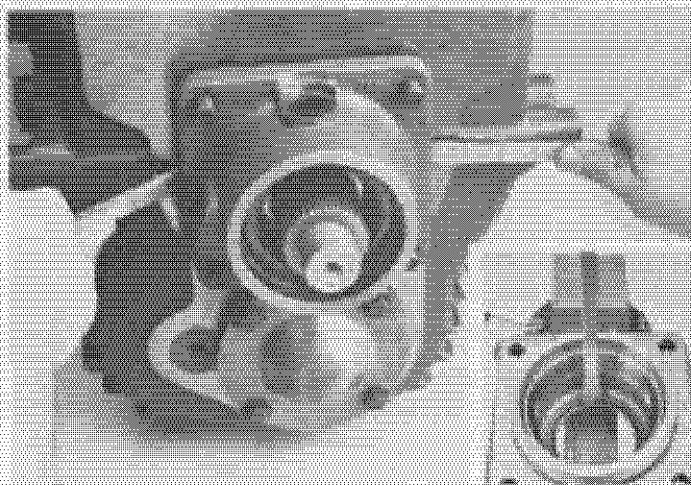

2. Turn out four retaining nuts and lockwashers. Using screwdrivers in notches, remove rear bearing cover. If necessary remove oil seal from cover (inset).

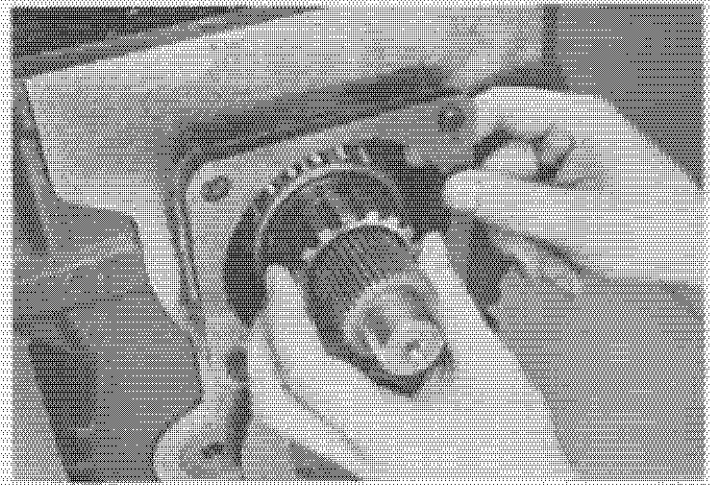

3. Remove shims and speedometer drive gear or rotor.
NOTE: Shims may come off with rear bearing cover.

DISASSEMBLY — TRANSMISSION

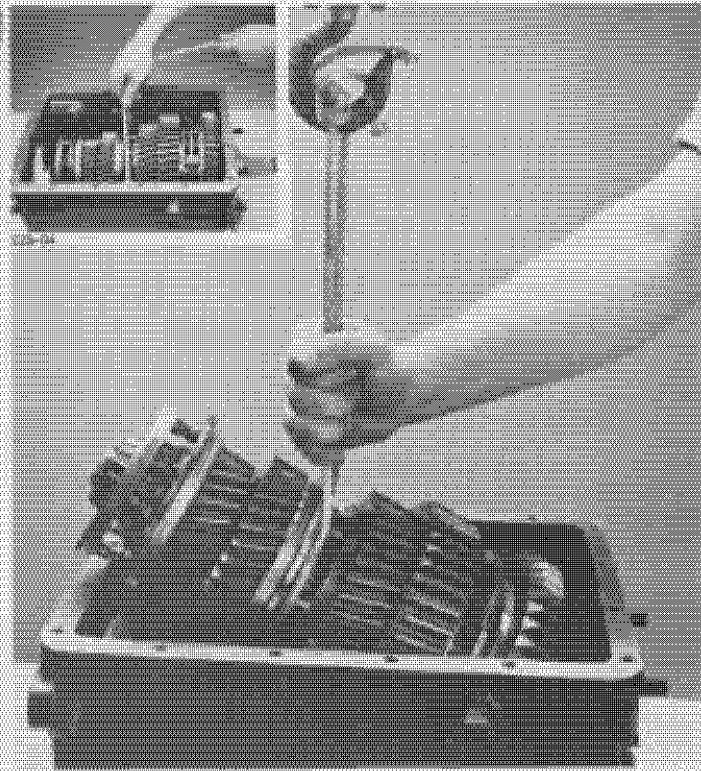

4. Wrap sling or rope around the 2nd-3rd synchronizer (inset). Use hoist to remove mainshaft assembly from case.

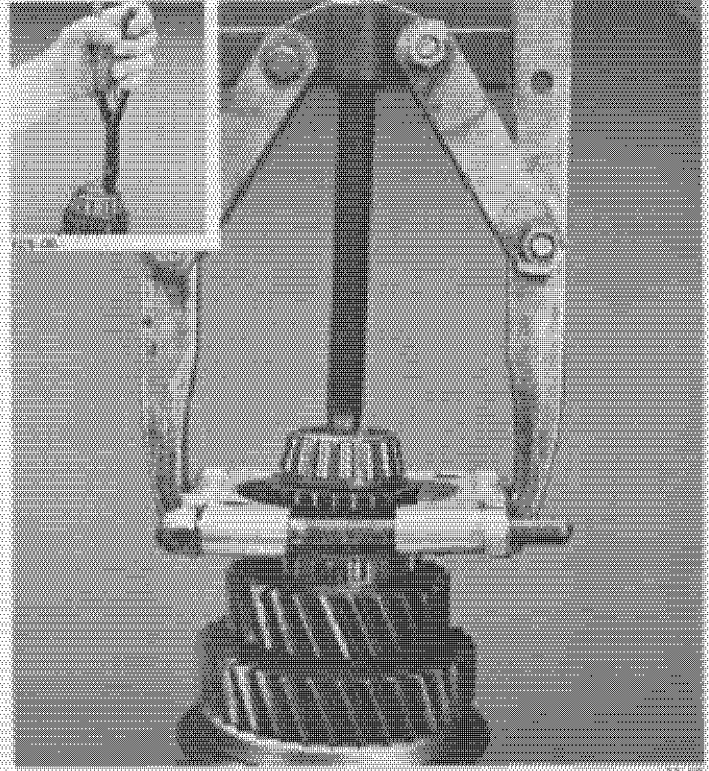

6. Remove snap ring from front of mainshaft front bearing (inset). Using a puller mounted behind 4th-5th shift hub, remove hub and bearing.



5. Install mainshaft assembly in vise equipped with soft jaws or wood, front of shaft facing up. Remove 4th-5th speed synchronizer and cups.



7. Remove 4th gear, bearings and spacer from mainshaft.

DISASSEMBLY — TRANSMISSION



8. Remove snap ring (inset), thrust washer, and locating ball.



10. Remove 3rd speed synchronizer cup and 2nd-3rd speed synchronizer.



9. Remove 3rd gear, bearings and spacer from main shaft.

DISASSEMBLY — TRANSMISSION

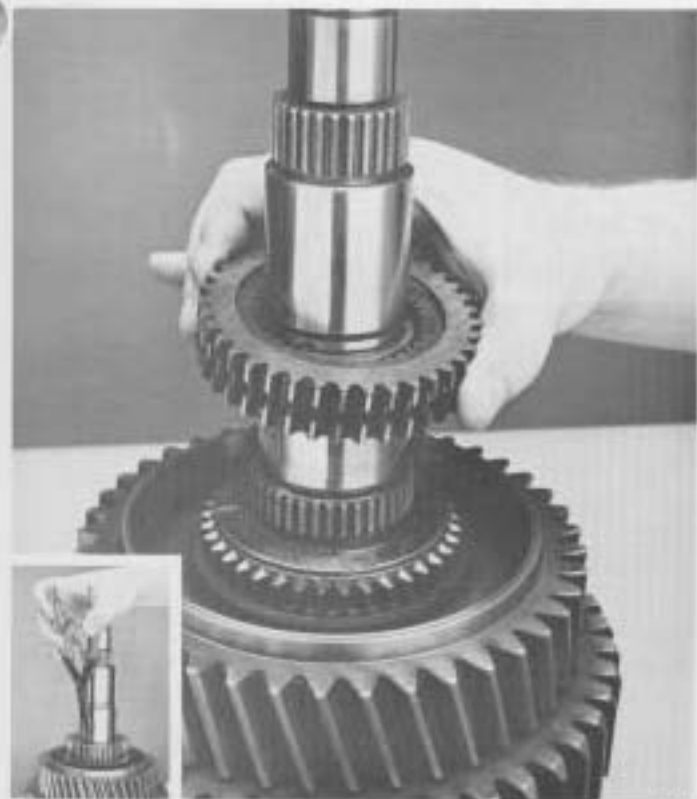

11. Remove snap ring (inset) and 2nd-3rd shift hub.



13. Remove snap ring (inset), thrust washer, and locating ball.



12. Remove 2nd gear, bearings, and spacer from mainshaft.

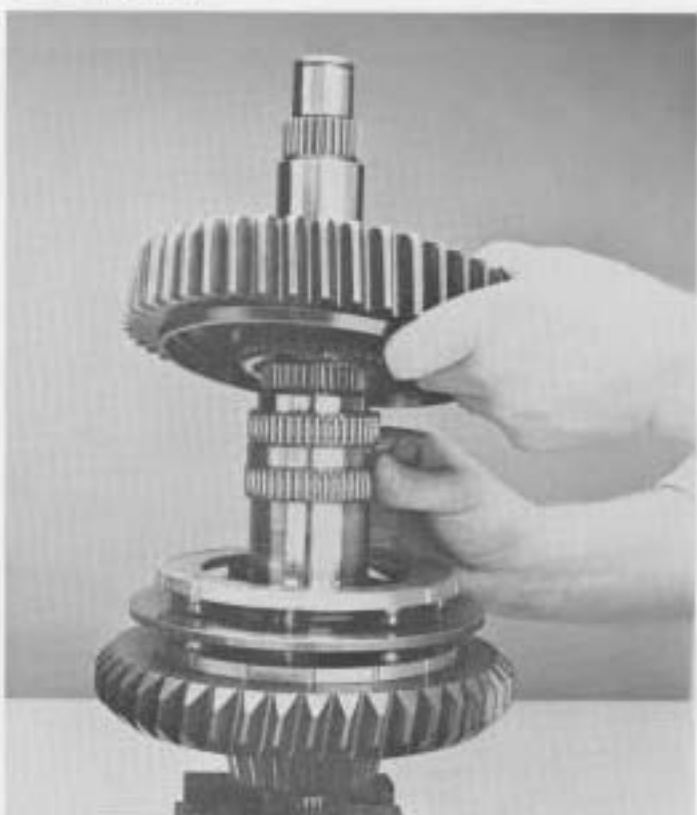

14. Remove 1st gear, bearings, and spacer from mainshaft.

DISASSEMBLY — TRANSMISSION



15. Remove 1st speed synchronizer.

32-15



17. Using a puller (inset), remove reverse gear, washer, and rear bearing.

32-17



16. Reposition mainshaft in vise, rear of shaft facing up.

32-16



18. Remove reverse gear bearings and spacer from mainshaft.

32-18

DISASSEMBLY — TRANSMISSION

C. Removal and Disassembly of Countershaft and Reverse Idler

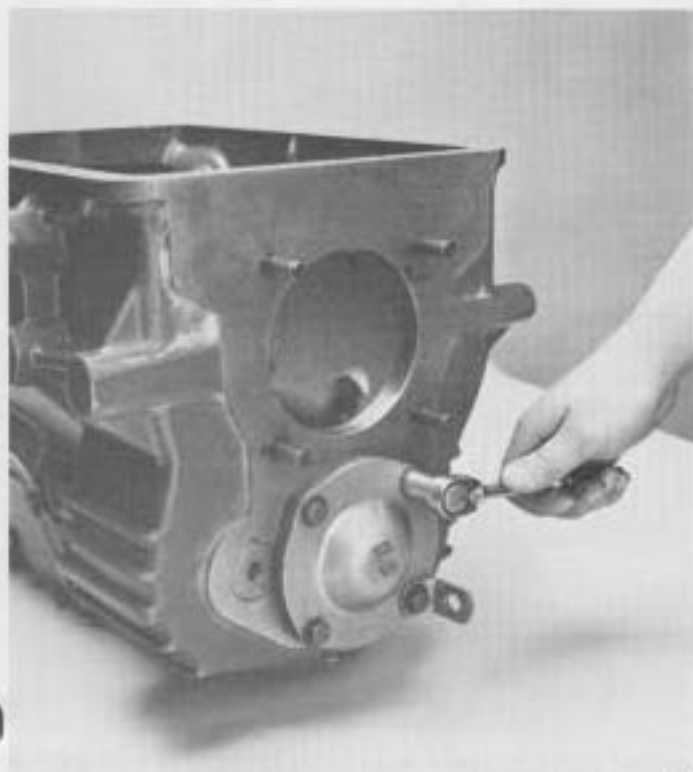
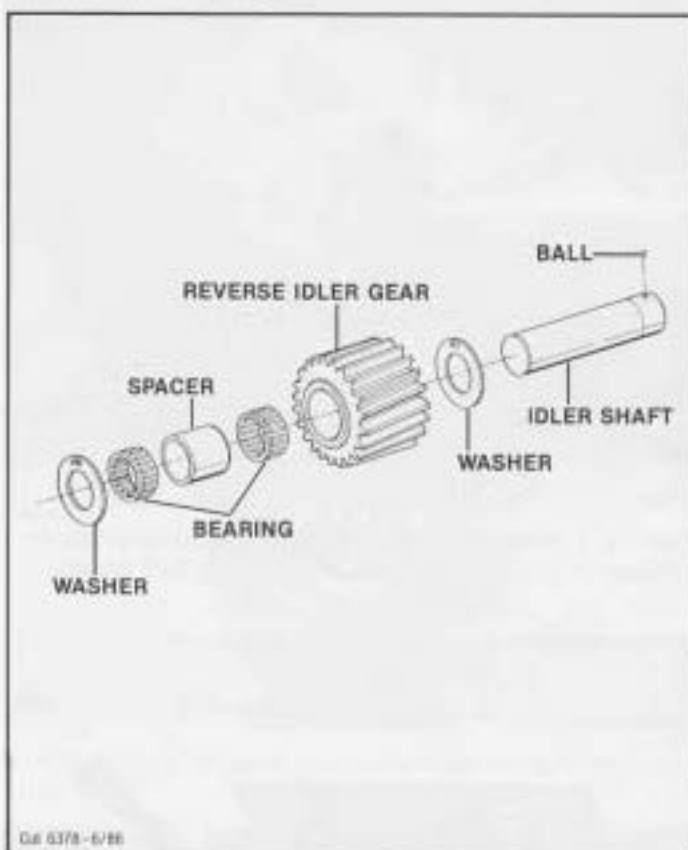
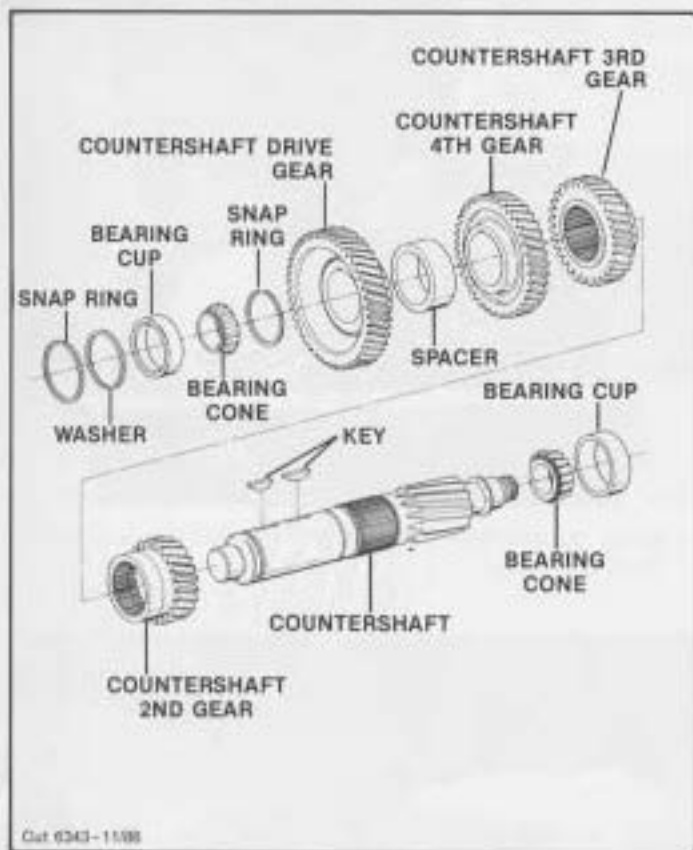

1. Turn out four cap screws, remove countershaft rear bearing cover and gasket.

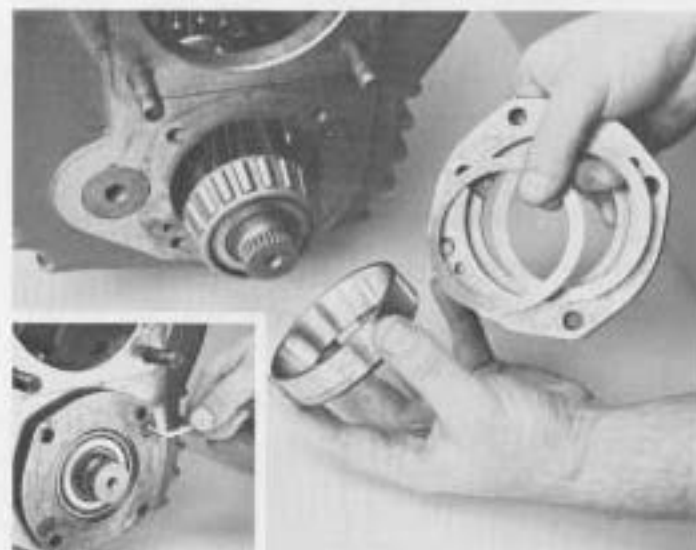

2. Turn out two set screws (inset). Remove bearing retainer, outer race, and shims.

NOTE: Countershaft may slide to the rear and out of bearing bore.

DISASSEMBLY — TRANSMISSION

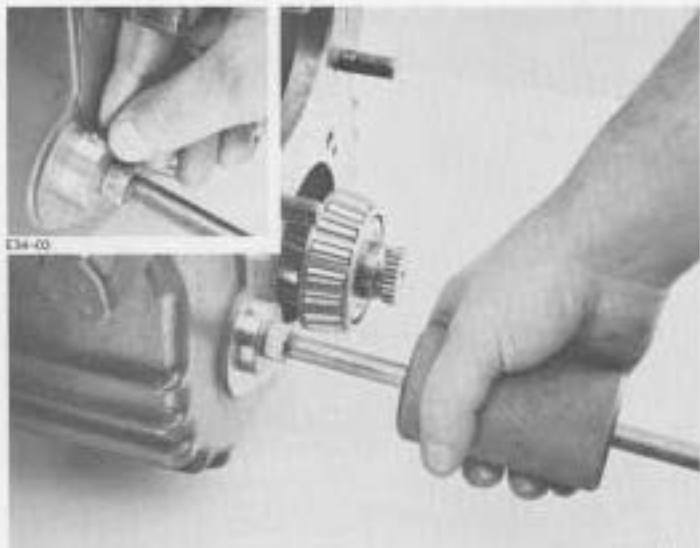

3. Using a slide hammer remove reverse idler shaft. Remove locating ball once it is exposed (inset).



5. Move countershaft assembly to the rear and lift it from the case.

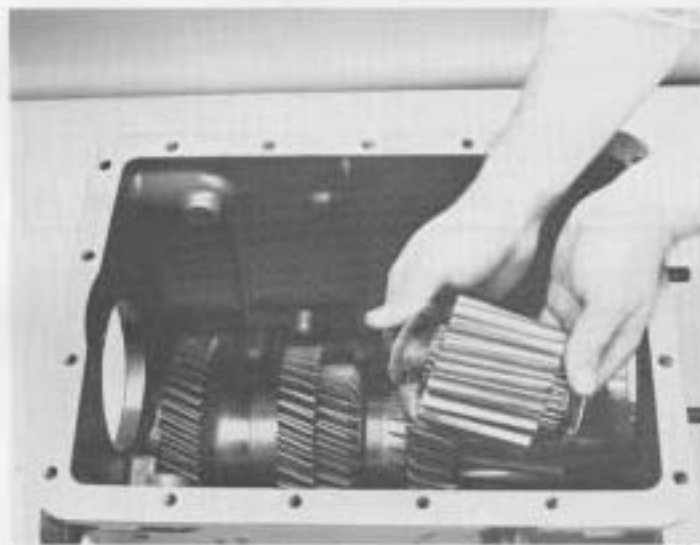

4. Remove reverse idler, bearings, spacer and thrust washers.



6. If countershaft front bearing race is to be replaced, drive bore plug through front of transmission and drive the race to the rear toward the inside of the case.

DISASSEMBLY — TRANSMISSION

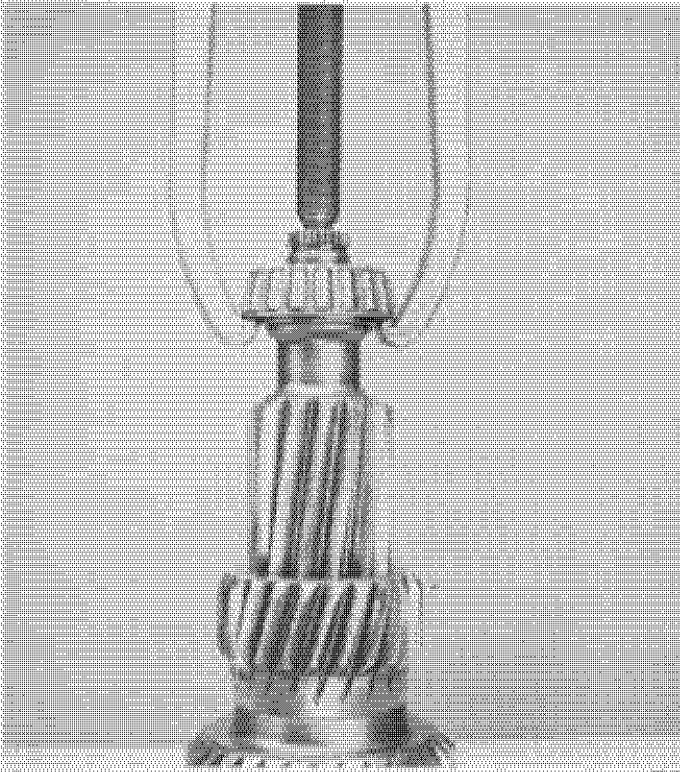

7. Position puller jaws behind rear countershaft bearing and remove bearing.

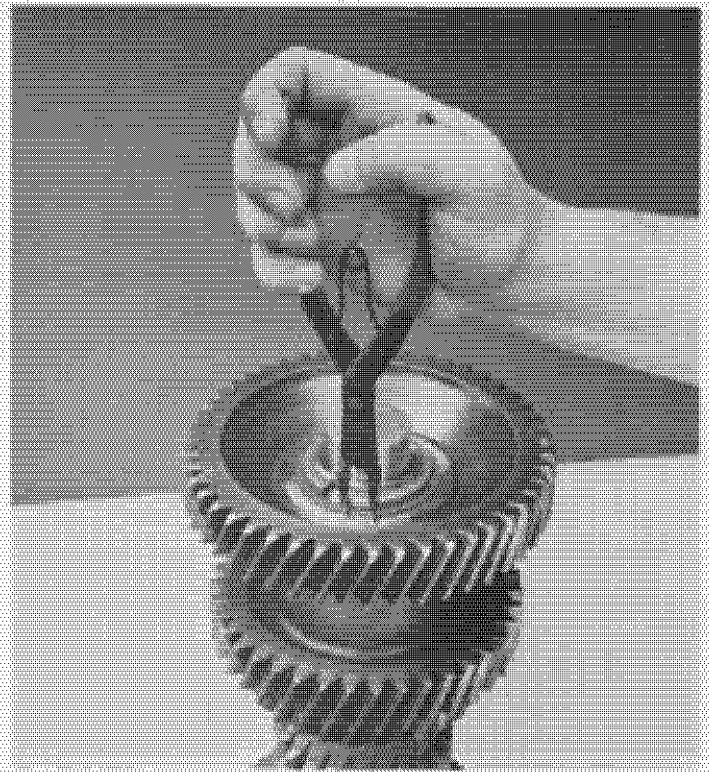

8. Remove drive gear retaining snap ring from front of shaft.

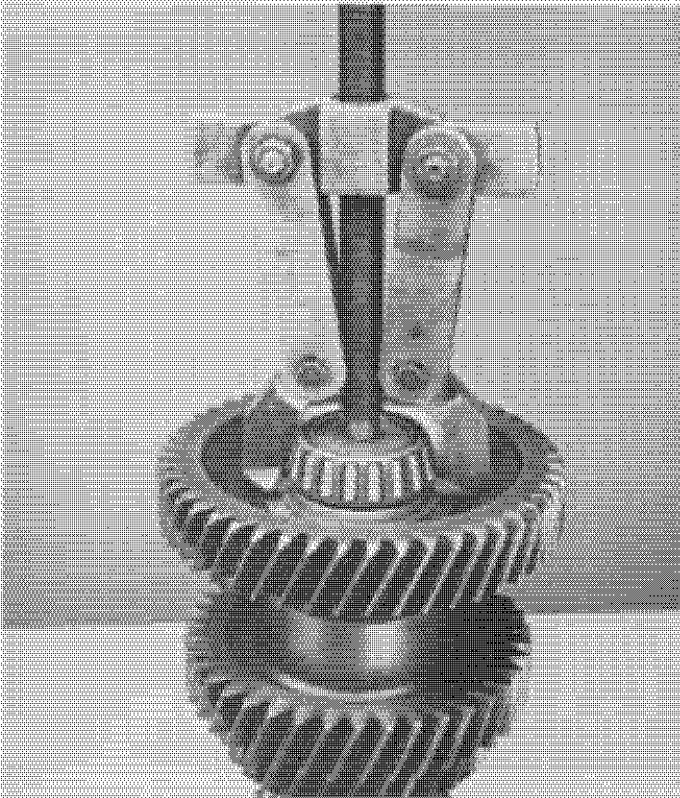

9. Position countershaft in vise, front of shaft facing up. Position puller jaws into notches behind front countershaft bearing and remove bearing.

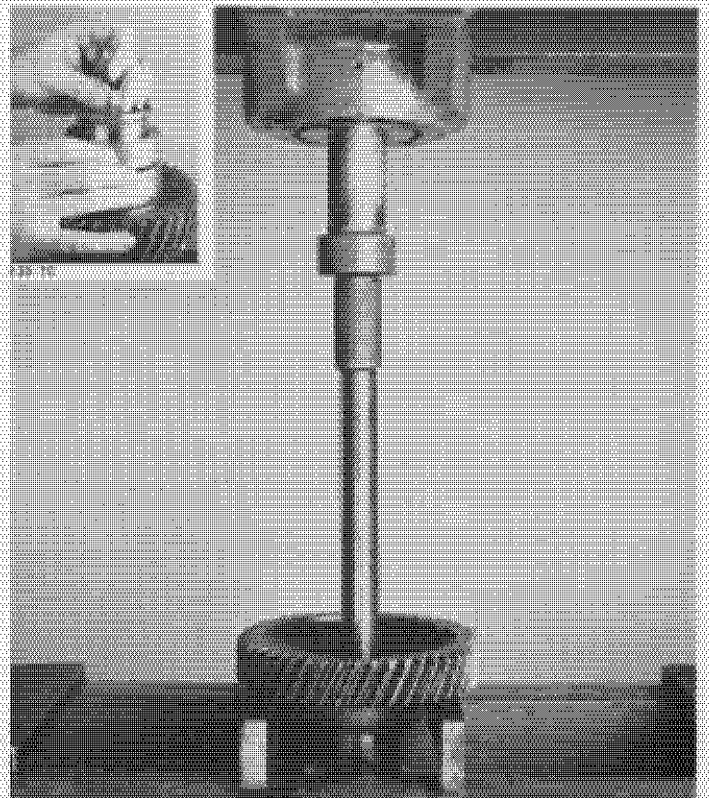

10. Use the rear face of the drive gear as a base, then press it from the countershaft as shown. Remove drive gear locating key from shaft (inset).

DISASSEMBLY — TRANSMISSION

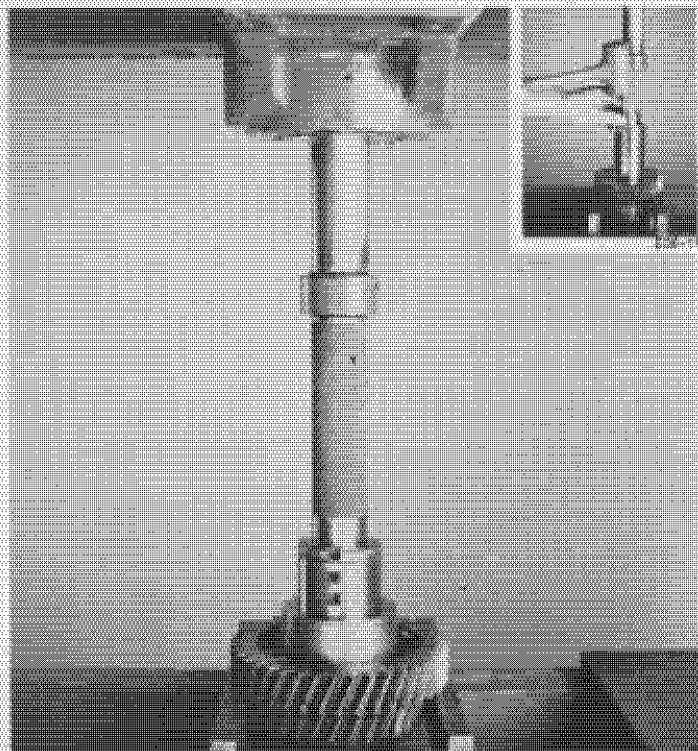

11. Using the rear face of 4th speed gear as a base, press it from the countershaft. Remove 4th gear key from shaft (inset).

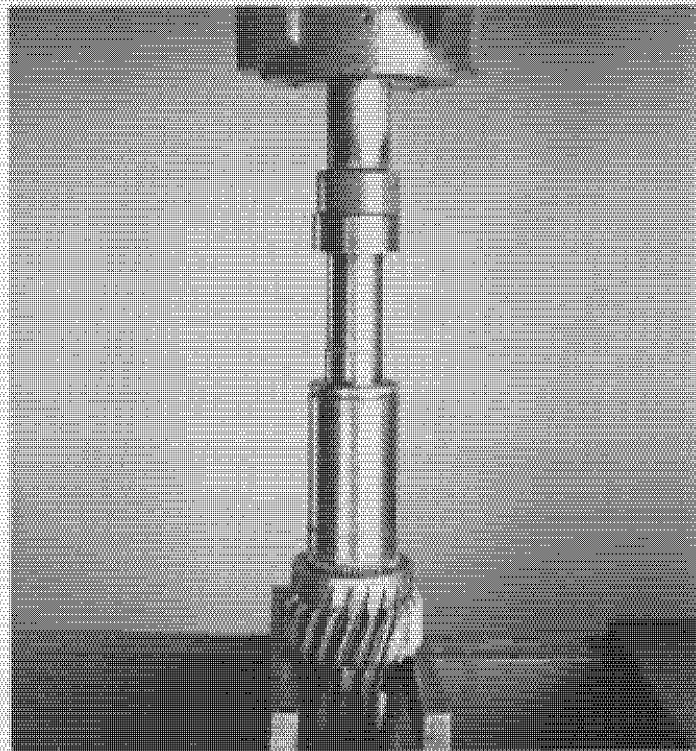

13. Using the rear face of 2nd speed gear as a base, press it from the countershaft.

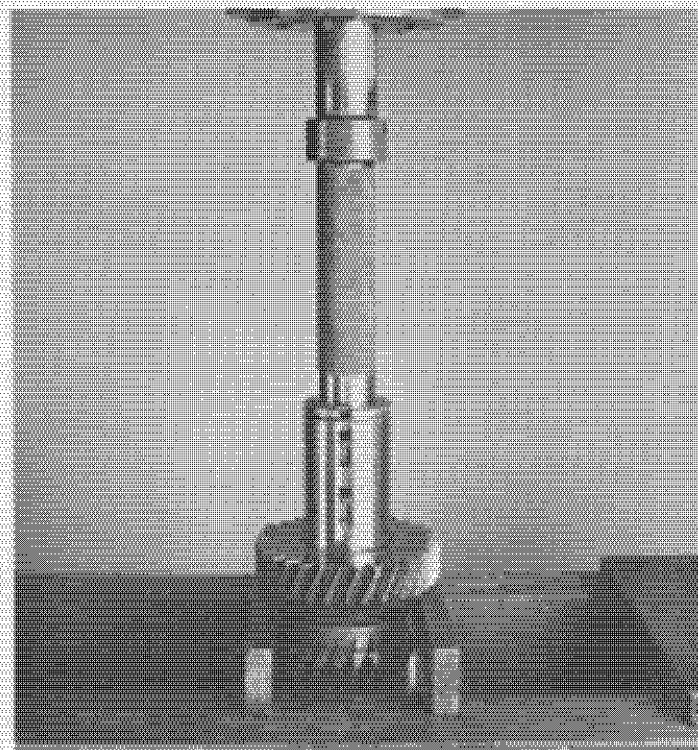

12. Using the rear face of 3rd speed gear as a base, press it from the countershaft.

NOTE: Be sure that 4th-5th speed gear keys have been removed before removing 3rd gear from countershaft.

REASSEMBLY — TRANSMISSION

A. Reassembly and Installation of Countershaft and Reverse Idler

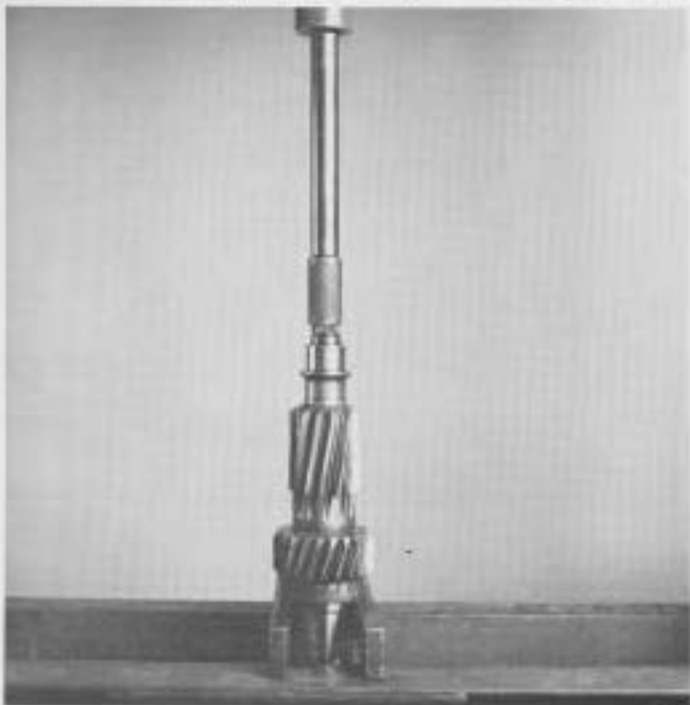

1. Press 2nd gear on countershaft as shown, long hub of gear to front of shaft.

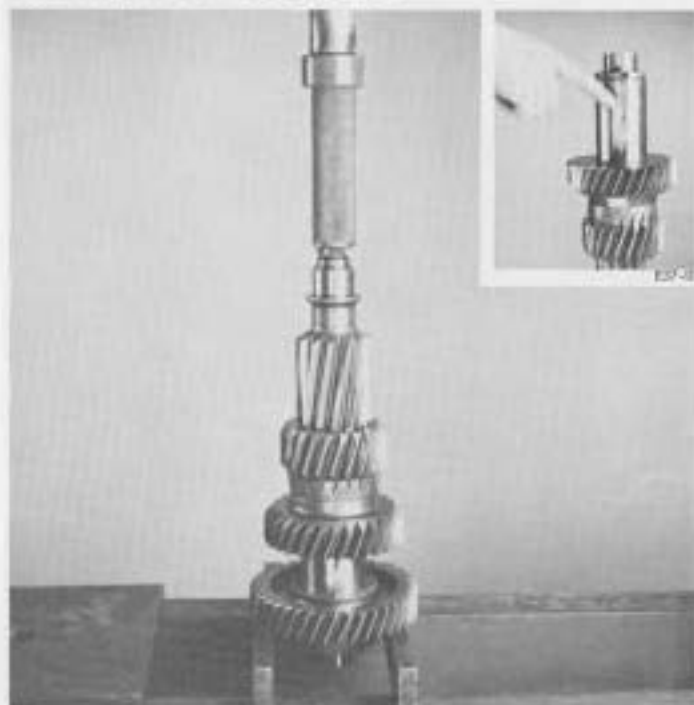

3. Install 4th and 5th speed gear keys on countershaft (inset). Align keyway of 4th speed gear to key on shaft. Press 4th gear on long hub of gear to front of shaft.

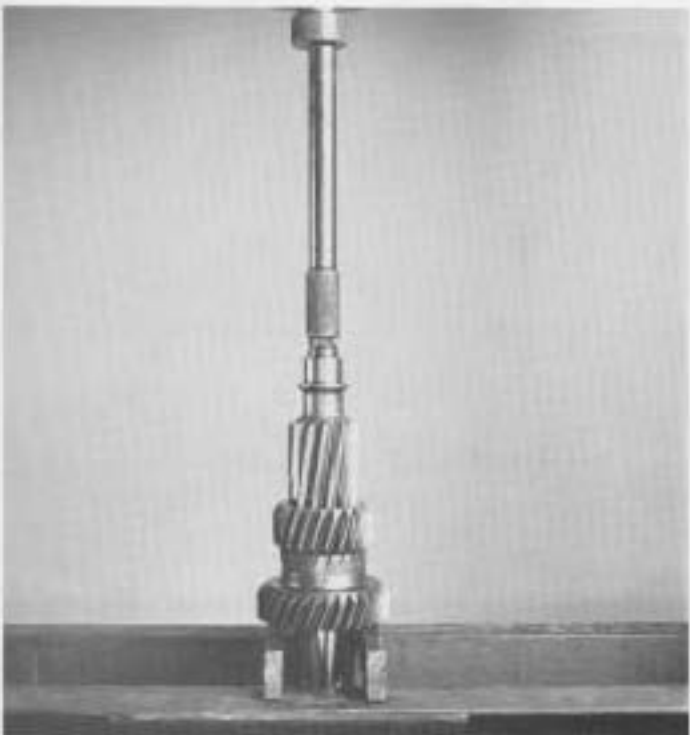

2. Press 3rd speed gear on countershaft, long hub of gear to rear of shaft.

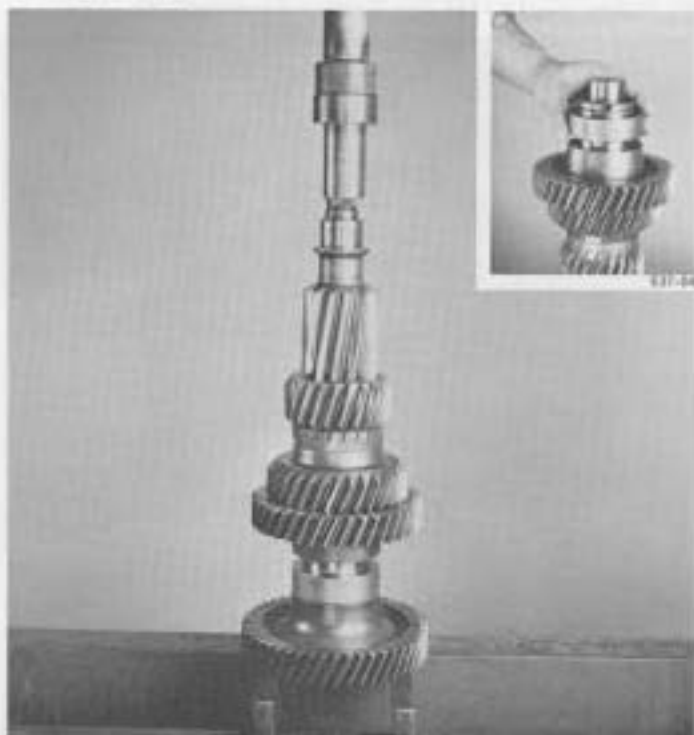

4. Remove 5th speed key from countershaft and install spacer (inset). Re-install key and align keyway of 5th speed gear with key on countershaft. Press 5th speed gear on shaft, long hub of gear to rear of shaft.

REASSEMBLY — TRANSMISSION



5. Install snap ring in groove at front of countershaft.

NOTE: This snap ring is available in two thicknesses. Use the widest snap ring that will seat in the groove of the countershaft. Refer to the Illustrated Parts List for further information.



6. Using a sleeve type driver, install front countershaft bearing as shown.



7. Using a sleeve type driver, install rear countershaft bearing as shown.



8. If previously removed, install snap ring, countershaft front bearing race (from inside of case) and bore plug. Coat outer diameter of bore plug with Loctite #510 before installing.

NOTE: Snap ring should be installed with open end aligned with lube trough in case.

REASSEMBLY — TRANSMISSION



9. Carefully lower countershaft into case.

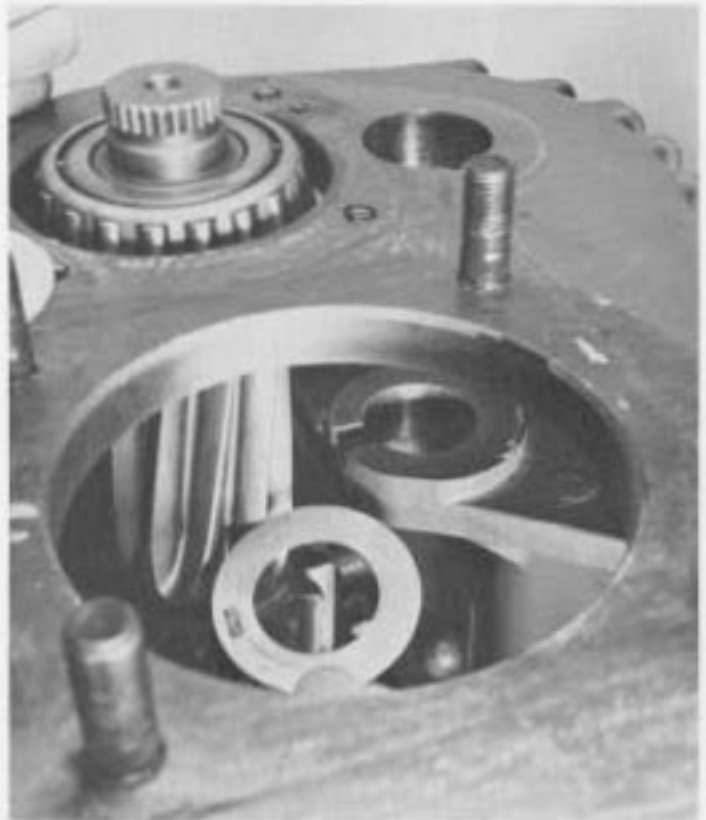

11. Use grease on reverse idler thrust washers to hold in place. Position tangs of washers in groove of housing.

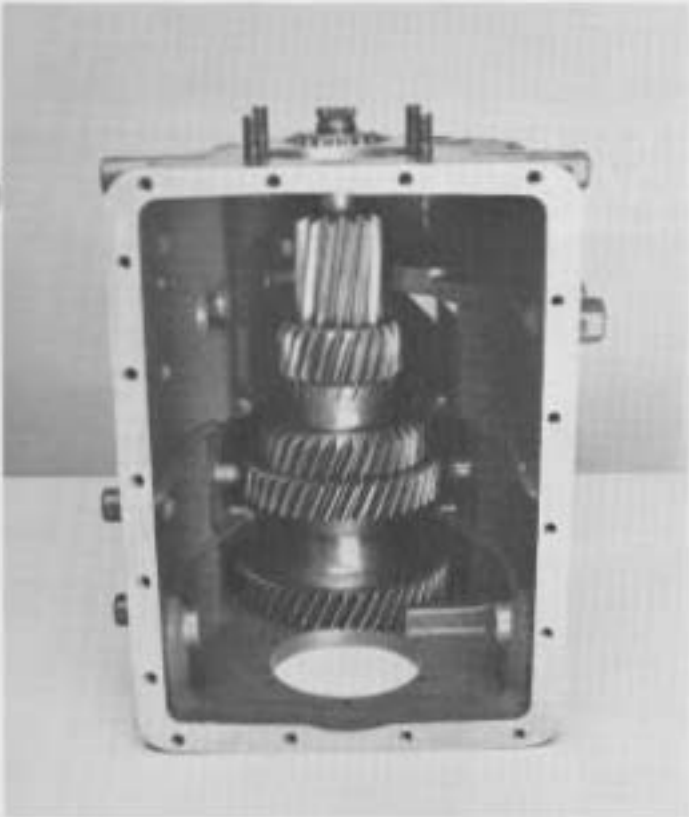

10. Turn transmission case on end as shown. Position countershaft assembly into front bearing race.

REASSEMBLY — TRANSMISSION

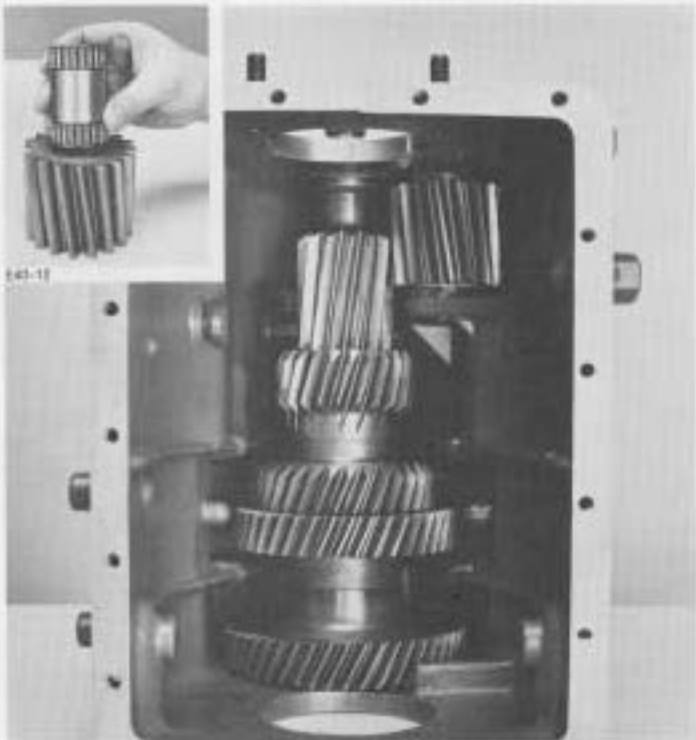

12. Install bearings and spacer in reverse idler gear (inset) and position gear in housing.
NOTE: Gear can be installed either way.



14. Install countershaft rear bearing race into case as shown.

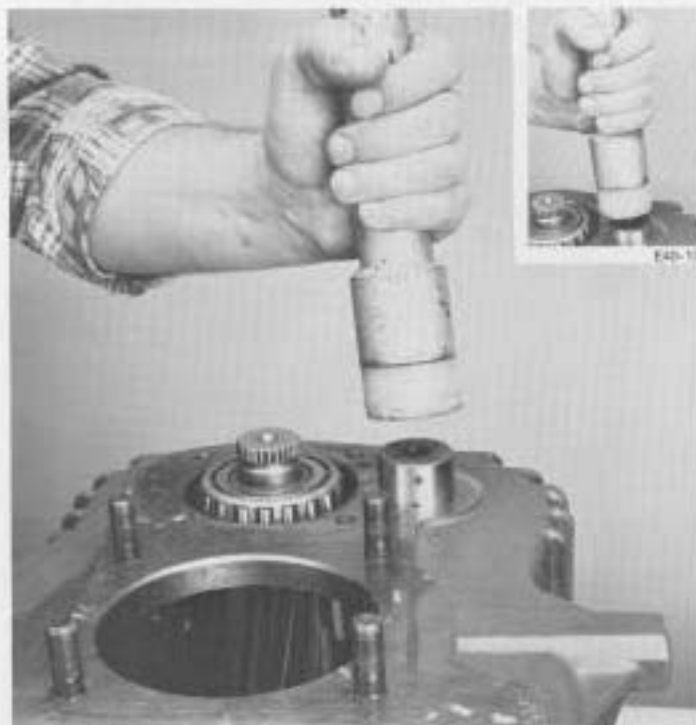

13. Insert idler shaft through case and idler gear bearings. Line up notch in shaft with notch in case, install lock ball, and drive shaft into position (inset).



15. Temporarily install new shims into bearing retainer (inset). Install retainer. Tighten set screws to 5-10 lbs. ft. (7-14 Nm).
NOTE: Lube hole in retainer must line up with lub hole in case.

REASSEMBLY — TRANSMISSION

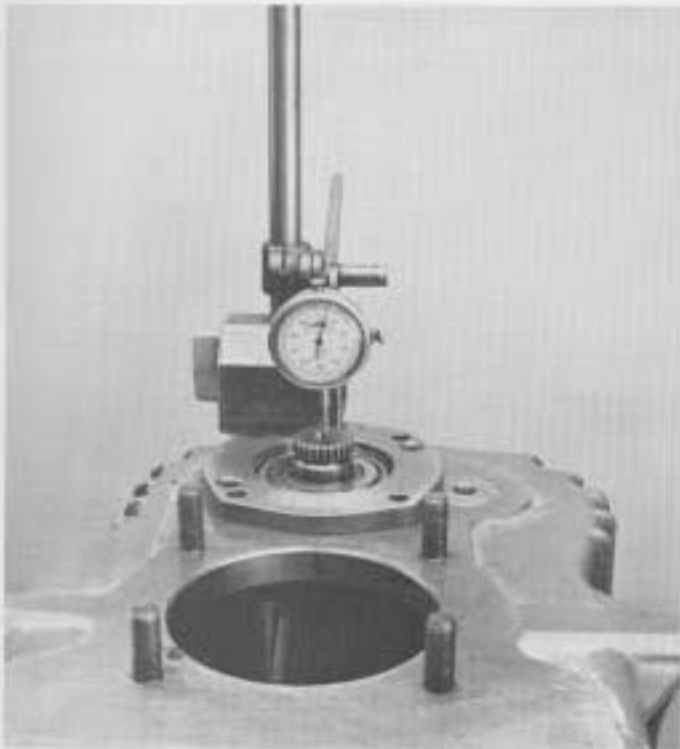

41-16

16. Rotate countershaft to seat bearings and races. Position dial indicator as shown, lift countershaft to measure end play. End play must be set at .002-.008 (0.05-0.20 mm). Add shims for more end play and remove shims for less end play.

NOTE: Once end play is correct remove retainer and apply a light coat of Loctite 510 to face of retainer.

Coat threads of set screws with Loctite 262 and retorque.



41-17

17. Install countershaft rear bearing cover and gasket. Coat threads of capscrews with Loctite 262 and torque to 20-30 lbs. ft. (27-41 Nm).

NOTE: Tip transmission to horizontal position to install mainshaft.

REASSEMBLY — TRANSMISSION

B. Reassembly and Installation of Mainshaft



42-01
1. Install mainshaft in vise equipped with wood or brass jaws, rear of mainshaft facing up. Lubricate and install reverse gear bearings with spacer between bearings as shown.



42-03
3. Install reverse gear washer. Washer can be installed either way.



42-02
2. Install mainshaft reverse gear, clutching teeth of gear facing down.

REASSEMBLY — TRANSMISSION



4. Using a sleeve type driver install rear mainshaft bearing as shown.

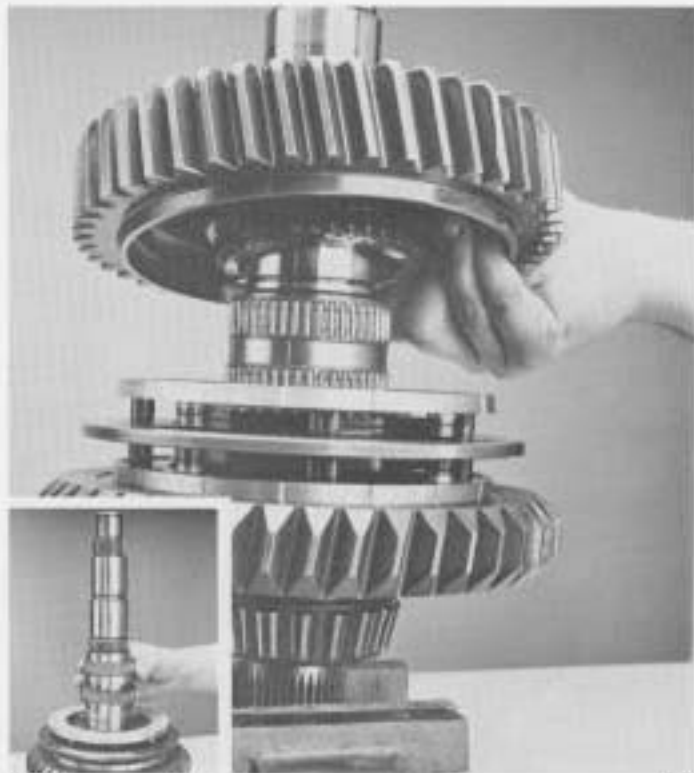

6. Lubricate and install 1st gear bearings and spacer (inset). Install 1st gear, clutching teeth facing down.

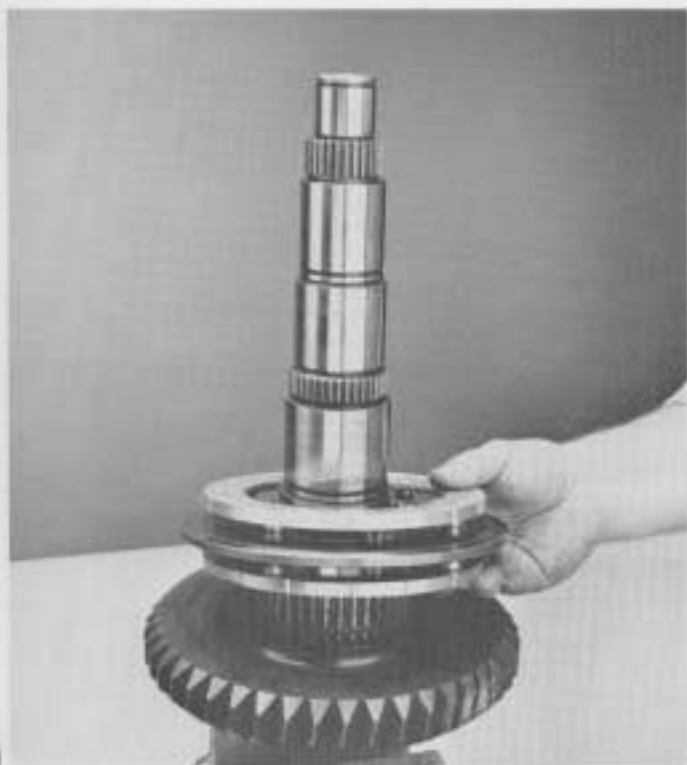

5. Reposition mainshaft in vise with front of mainshaft facing up. Lubricate friction surface with transmission lube and install 1st speed synchronizer.



7. Install locating ball and washer. Washer can be installed either way. Install snap ring as shown (inset).

REASSEMBLY — TRANSMISSION

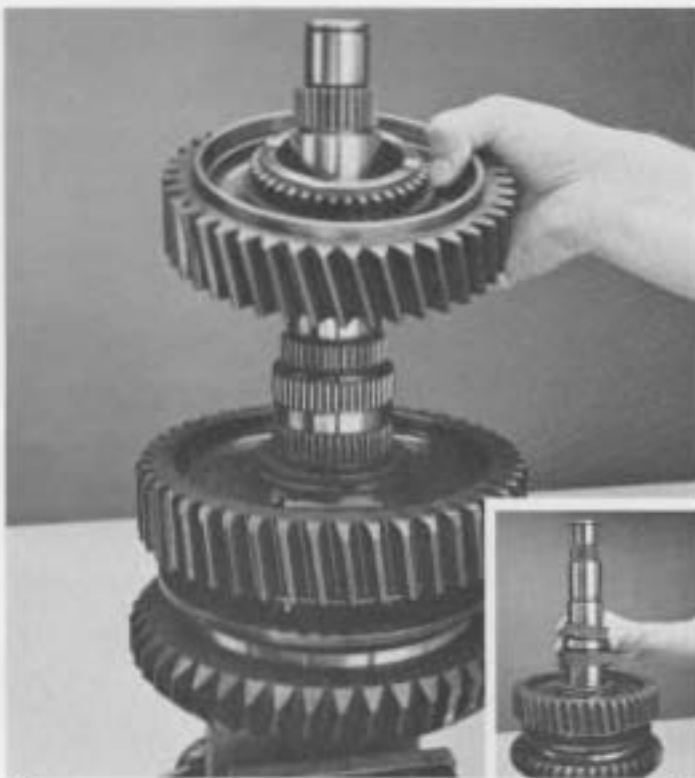

8. Lubricate and install 2nd gear bearings and spacer (inset). Install 2nd gear, clutching teeth facing up.



10. Lubricate friction surface with transmission lube and install 2nd-3rd speed synchronizer and 3rd speed synchronizer cup.



9. Install 2nd-3rd clutch hub with stepped face of hub facing up. Install snap ring in groove of mainshaft (inset).



11. Lubricate and install 3rd gear bearings and spacer (inset). Install 3rd gear, clutching teeth facing down.

REASSEMBLY — TRANSMISSION



12. Install locating ball and washer. Washer can be installed either way. Install snap ring as shown (inset).



14. Install 4th-5th clutch hub with shoulder end of hub facing down.



13. Lubricate and install 4th gear bearings and spacer (inset). Install 4th gear, clutching teeth facing up.



15. Install 4th speed synchronizer cup (inset). Lubricate friction surface with transmission lube and install 4th-5th speed synchronizer assembly and 5th speed synchronizer cup.

REASSEMBLY — TRANSMISSION



16. Using a sleeve type driver install front mainshaft bearing. Install snap ring in groove on end of shaft (inset).

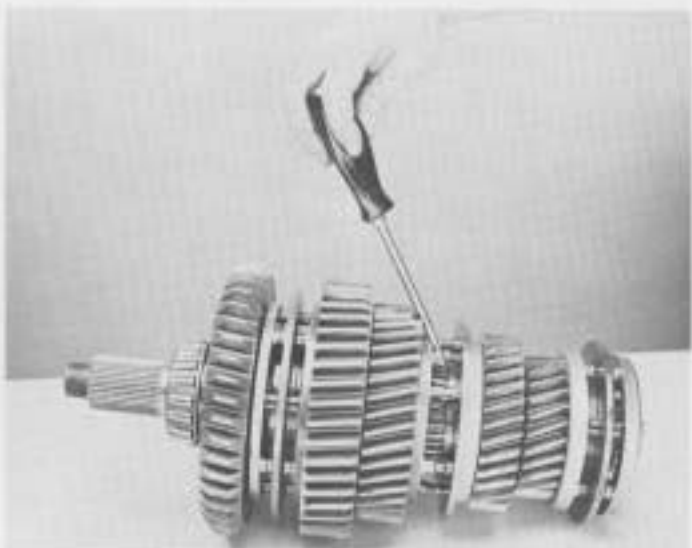

17. Remove mainshaft assembly from vise and place on bench. Shift synchronizer into 3rd gear.



18. Using a sling or rope around the 2nd-3rd synchronizer carefully lower mainshaft into case.



19. Using a sleeve type driver install bearing on input shaft.

REASSEMBLY — TRANSMISSION

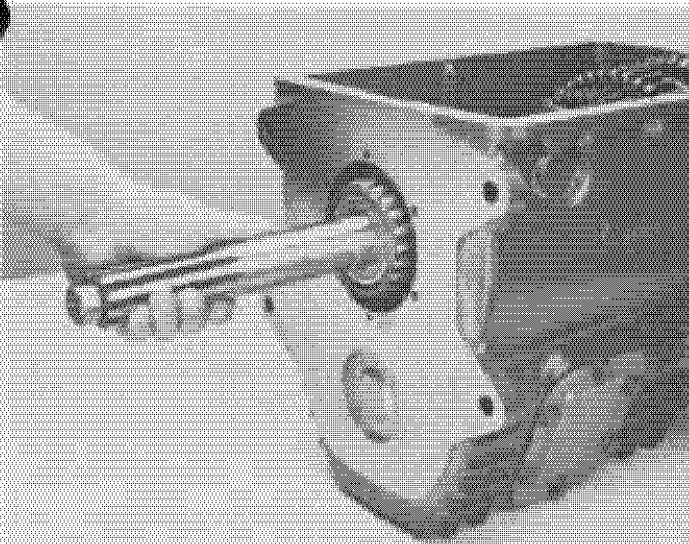

20. Install input shaft by aligning clutching teeth on main drive gear with teeth in 5th speed synchronizer cup.

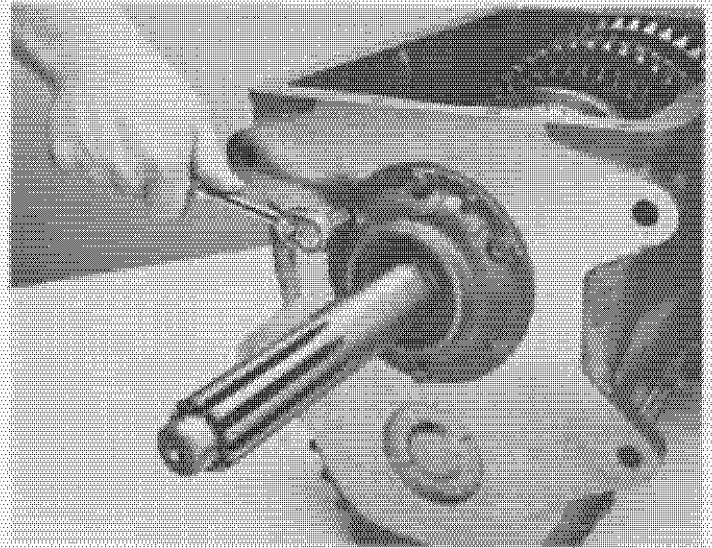

22. Install input shaft bearing cover and gasket. Apply Loctite 262 to threads of capscrews and torque to 15-20 lbs. ft. (20-27 Nm).
NOTE: Top of bearing cover is marked for proper installation.

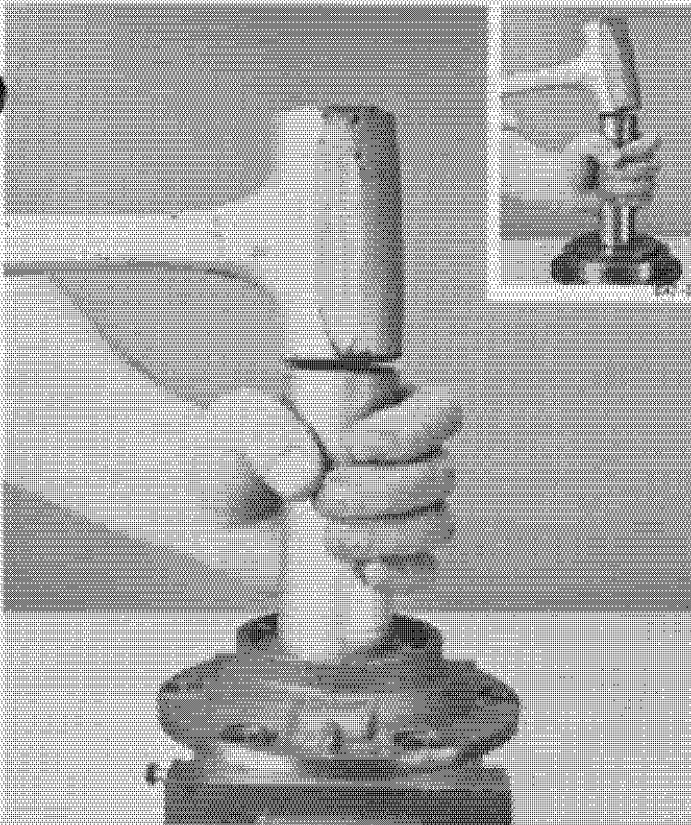

21. Coat outer diameter of input shaft bearing cover oil seal with Loctite 510. Install seal with flanged driver as shown. Install input shaft bearing race (inset).

NOTE: On stem type bearing caps the oil seal and bearing race must be installed from the rear.

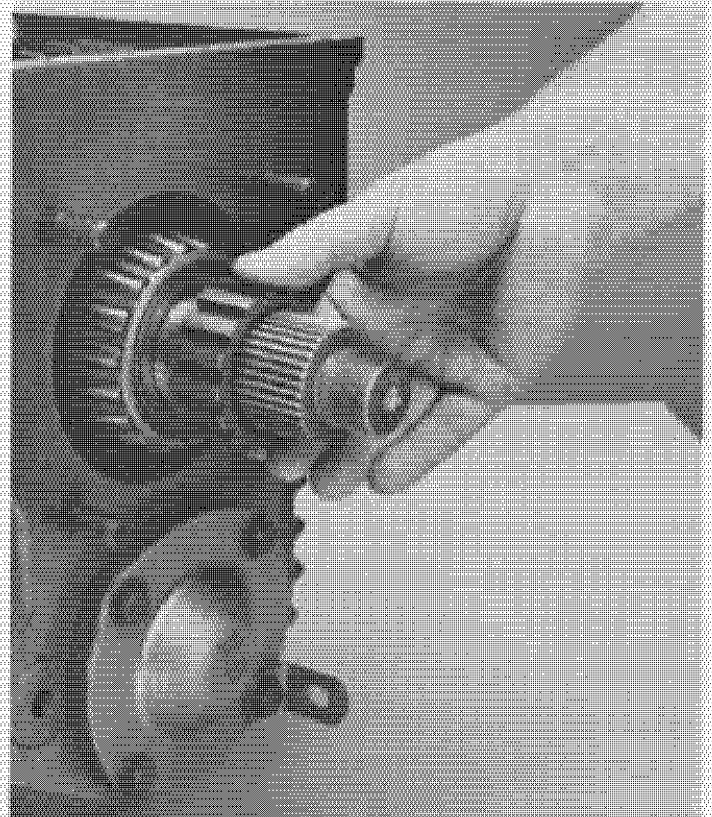

23. Install speedometer drive gear or rotor on output shaft.

REASSEMBLY — TRANSMISSION



46-24
24. If previously removed install rear bearing race (inset). Temporarily install shims and rear bearing cover. Tighten nuts to 60-70 lbs. ft. (81-95 Nm).

NOTE: Top of rear bearing cover is marked for proper installation.



46-25
25. Place transmission in a vertical position as shown. Install yoke and nut. Torque yoke nut to 300-350 lbs. ft. (407-475 Nm). Rotate input shaft and mainshaft to seat bearings and races.



46-25
26. Position dial indicator as shown. Pry up on output shaft to measure end play. End play must be set at .002-.008 (0.05-0.20 min). Add shims for more end play, remove shims for less end play.

NOTE: Once end play is correct remove yoke and rear bearing cover and apply a light coat of Loctite 510 to both sides of shims.



48-21
27. If new oil seal is required, install using a flanged driver. Coat outer diameter of oil seal with Loctite 510.

REASSEMBLY — TRANSMISSION



28. Install rear bearing cover and shims. Tighten nuts to 60-70 lbs. ft. (81-95 Nm). Top of rear bearing cover is marked for proper installation. Install speedometer driven gear and sleeve.

INSTALLATION—CLUTCH HOUSING AND YOKE

A. Installation of Clutch Housing

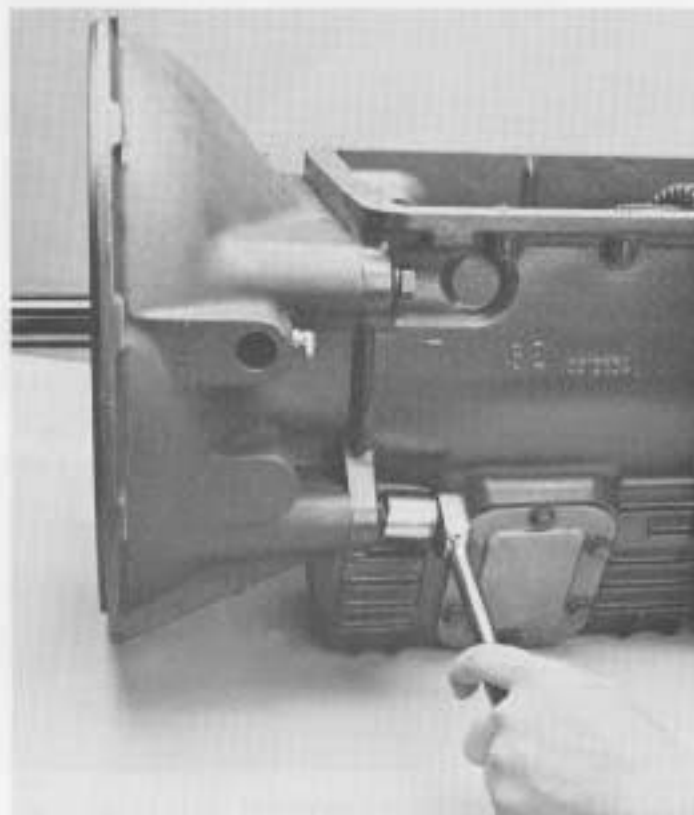

1. Position clutch housing on front of transmission. Install four retaining bolts and torque to 145-155 lbs. ft. (196-210 Nm).

B. Installation of Yoke

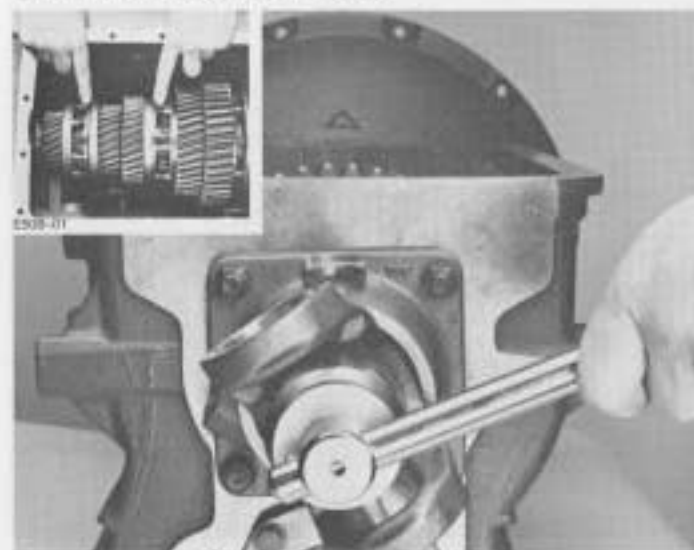

1. Lock the transmission by engaging two mainshaft gears (inset). Carefully install yoke and nut. Tighten nut to 300-350 lbs. ft (407-475 Nm).

INSTALLATION—SHIFTING CONTROLS

A. Shift Bar Housing

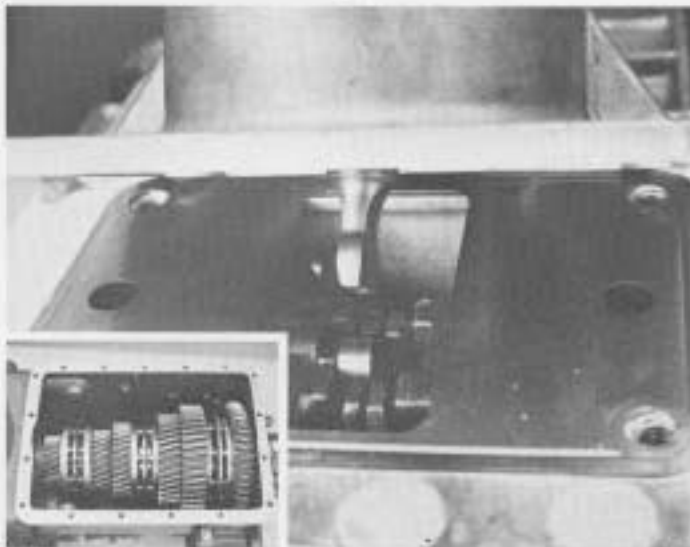

1. Place transmission in neutral (inset) and install gasket on case. Place shift bar housing in neutral and install on case making sure shift yokes align with corresponding synchronizers and sliding clutch.



3. Install remaining capscrews and torque to 20-25 lbs. ft (27-34 Nm).



2. Apply Loctite 262 to threads of capscrews. Install two capscrews into alignment holes of shift bar housing and torque to 20-25 lbs. ft (27-34 Nm).

INSTALLATION—CLUTCH HOUSING

INSTALLATION—SHIFTING CONTROLS

B. Gear Shift Lever Housing Assembly

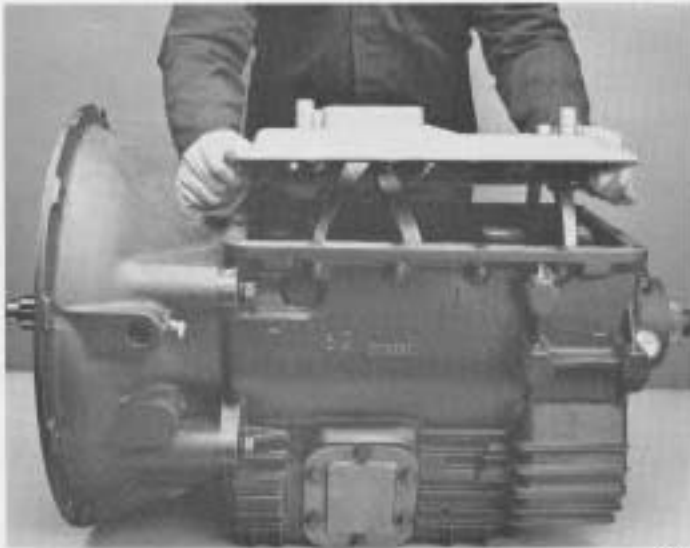

52-01

1. With the shift bar housing in the neutral position, install gasket and gear shift lever assembly on the shift bar housing. Fit gear shift lever in corresponding finger assembly in bar housing as lever is installed.

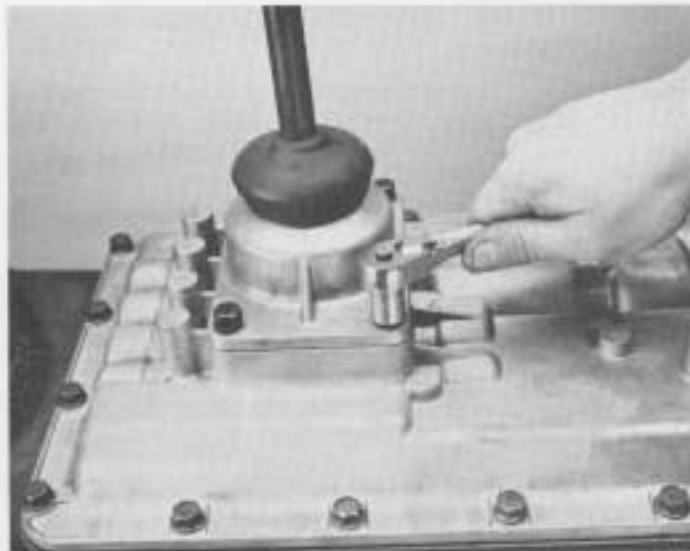

52-02

2. Coat threads of retaining capscrews with Loctite 262 and install. Torque capscrews to 20-25 lbs. ft. (27-34 Nm).

OPTIONS

REMOTE CONTROL

SHIFT SHAFT

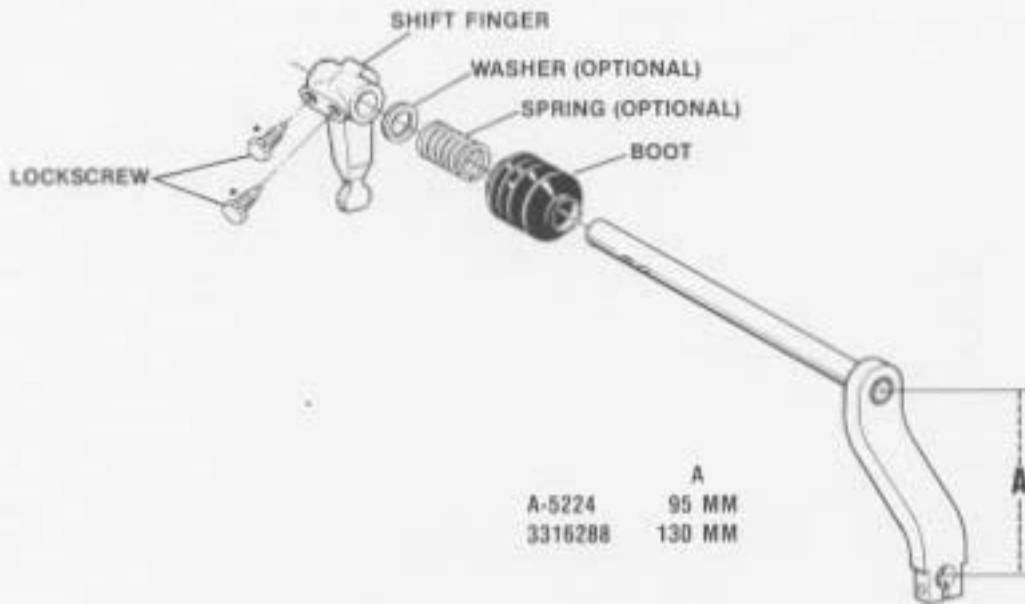

*NOTE: Use lockwire at these positions

Cat 727-6186

HOUSING ASSEMBLY

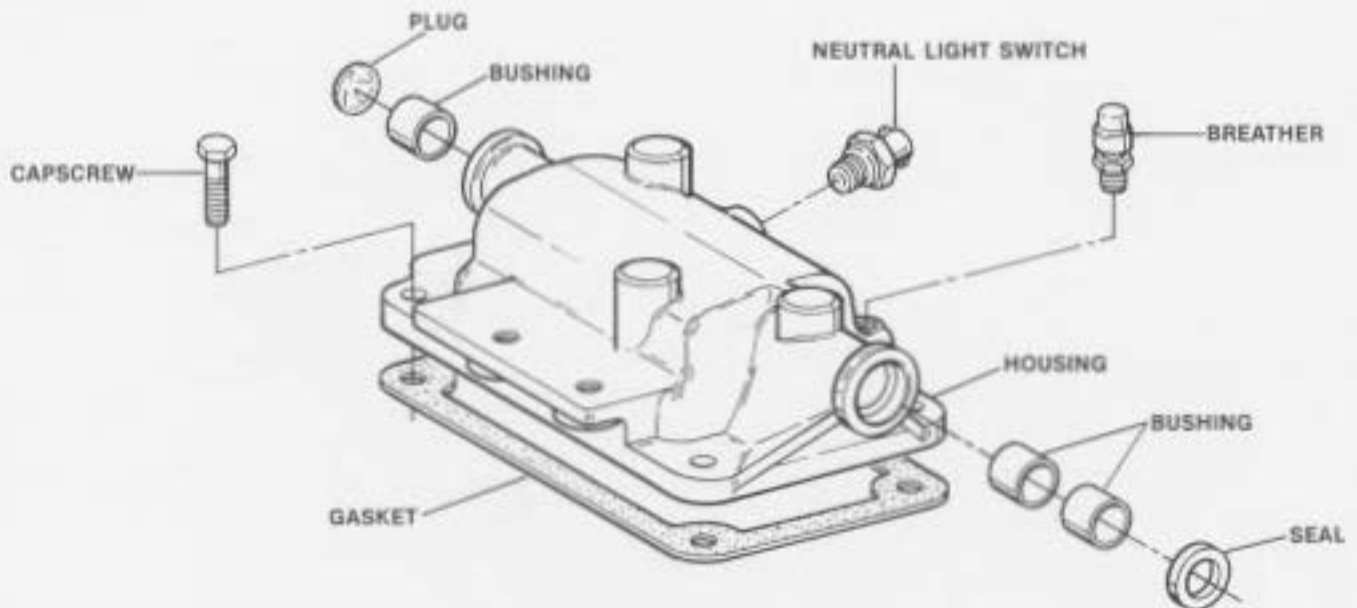

Cat 728-6186

Copyright Eaton Corporation, 2012. Eaton hereby grant their customers, vendors, or distributors permission to freely copy, reproduce and/or distribute this document in printed format. It may be copied only in its entirety without any changes or modifications. THIS INFORMATION IS NOT INTENDED FOR SALE OR RESALE, AND THIS NOTICE MUST REMAIN ON ALL COPIES.

Note: Features and specifications listed in this document are subject to change without notice and represent the maximum capabilities of the software and products with all options installed. Although every attempt has been made to ensure the accuracy of information contained within, Eaton makes no representation about the completeness, correctness or accuracy and assumes no responsibility for any errors or omissions. Features and functionality may vary depending on selected options.

For spec'ing or service assistance, call 1-800-826-HELP (4357) or visit www.eaton.com/roadranger. In Mexico, call 001-800-826-4357.

Roadranger: Eaton and trusted partners providing the best products and services in the industry, ensuring more time on the road.

Eaton Corporation

Vehicle Group
P.O. Box 4013
Kalamazoo, MI 49003 USA
800-826-HELP (4357)
www.eaton.com/roadranger

Printed in USA

For parts or service call us
Pro Gear & Transmission, Inc.



1 (877) 776-4600

(407) 872-1901

parts@eprogear.com

906 W. Gore St.

Orlando, FL 32805

