

Fuller Synchronesh Transmissions TRSM6109

October 2007



Powering Business Worldwide

BACKED BY

Roadranger

SUPPORT

For parts or service call us
Pro Gear & Transmission, Inc.



1 (877) 776-4600

(407) 872-1901

parts@eprogear.com

906 W. Gore St.

Orlando, FL 32805



Section 1 General

1/1	Model Designation
1/2	General Description - Features
1/2	Epicyclic Reduction Gear
1/3	Gear Change Pattern
1/5	Power Flow Diagrams
1/6	Technical Data
1/10	Lubrication
1/11	Recommended Lubricants
1/13	Torque Tightening Recommendations
1/17	Disassembly Precautions and Inspection of Expendable Parts
1/19	Reassembly Precautions
1/20	Gear End Floats
1/21	Special Tools
1/25	Locally Made Tools

Section 2 Air System

2/1	General Description - 9 Speed
2/3	Single H Pattern Gear Change Air Connections
2/3	Single H Pattern Gear Change Air Connections - Mecman
2/3	Double H Pattern Gear Change Air Connections
2/4	Filter Pressure Regulator
2/5	Selector Valve - Removal and Refitment
2/6	Slave Air Valve - Function
2/6	Slave Valve Renewal
2/8	Range Change - Shift Cylinder Operation
2/8	Range Change Cylinder - Trouble Shooting Hints
2/9	Air system - General Identification
2/10	Range Change Shift Air Circuit Diagrams - Double H
2/11	Range Change Shift Air Circuit Diagrams - Single H
2/13	Air System - Single H
2/14	Range Change Shift Air Circuit Diagrams (continued)
2/17	Air System - Single H (Mecman)

Section 3 Shifting Controls

3/1	Remote Control, Single H - Exploded View
3/2	Remote Control Disassembly
3/4	Remote Control Reassembly
3/7	Remote Control, Double H - Exploded View
3/8	Remote Control Disassembly
3/10	Remote Control Reassembly

Section 4 Main Transmission Overhaul

- 4/1 Transmission Case - Exploded View (horizontal transmission)
- 4/2 Transmission Case - Exploded View (vertical transmission)
- 4/3 Main Transmission Disassembly
- 4/12 Casing Bushes Renewal
- 4/13 Rear Case Assembly - Exploded View
- 4/14 Rear Case Disassembly
- 4/18 Planet Gear Carrier Disassembly
- 4/19 Planet Gear Carrier Reassembly
- 4/21 Rear Case Reassembly
- 4/27 Input Shaft Disassembly
- 4/28 Input Shaft Reassembly
- 4/29 Layshaft Disassembly
- 4/30 Layshaft Reassembly
- 4/32 Mainshaft - Exploded View
- 4/33 Mainshaft Disassembly
- 4/37 Mainshaft Reassembly
- 4/44 Selector Shaft - Single H - Disassembly
- 4/45 Selector Shaft - Single H - Reassembly
- 4/46 Selector Shaft - Double H - Disassembly
- 4/47 Selector Shaft - Double H - Reassembly
- 4/49 Transmission Case Reassembly

Section 5 Changing the Input Shaft

- 5/1 Input Shaft Disassembly
- 5/2 Input Shaft Reassembly

Section 6 Clutch Housing

- 6/1 Clutch Housing - Disassembly
- 6/2 Clutch Housing - Reassembly

Section 1 General

General

Model designation

Example: FSO-6109A

- FS - Standard prefix
- O - Overdrive
- 6 - Input torque code
- 1 - Series 1
- 09 - Number of forward gears
- A - Standard ratio set
- B, C - Alternative ratio sets

Transmission Identification

All transmissions are fitted with an identification plate on the left hand side of the front case showing

1. Transmission serial number.
2. Transmission model.
3. Manufacturing data code.
4. Transmission specification number.

The transmission specification number is unique to each customer and gives precise details of the transmission design level. This number must be quoted when ordering replacement parts.

General

General description

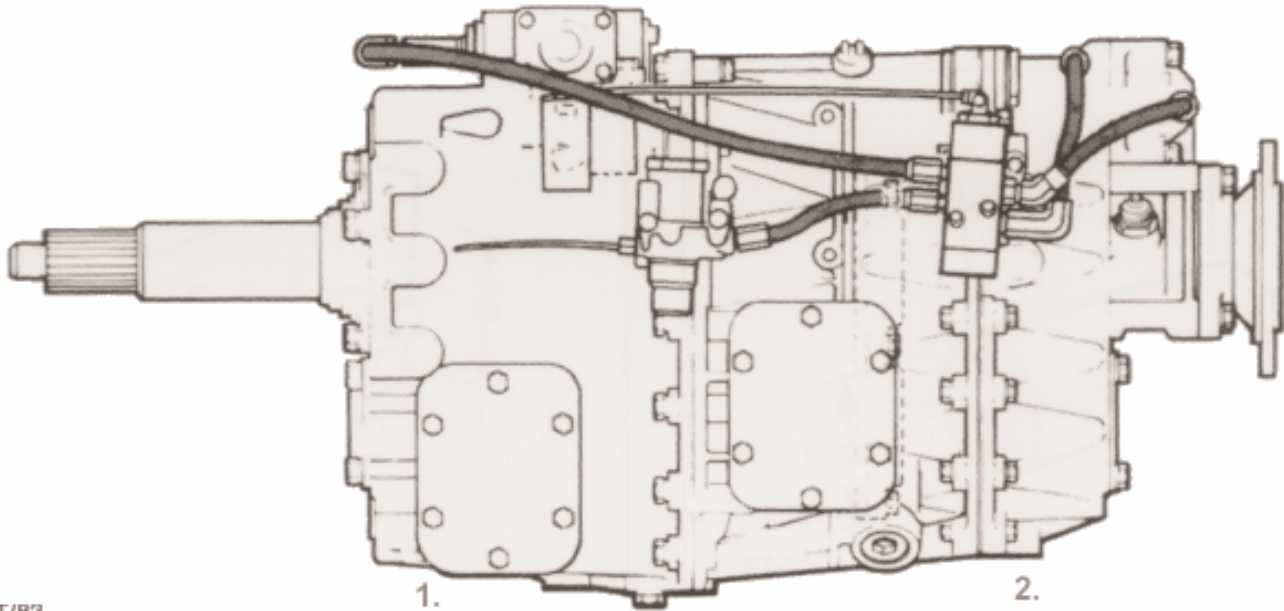

1. Main section

2. Range change section

Features

The Eaton 9-speed transmissions have nine forward speeds and are part of a medium duty range of synchromesh transmissions. They have a simple shift pattern using a unique single rail selector mechanism. Direct drive or overdrive top gear versions are available. An epicyclic reduction gear with air operated synchromesh engagement is located between the 5-speed main section of the transmission and the output flange. With the reduction gear engaged, low (crawler) gear and 1st, 2nd, 3rd and 4th gears can be selected and engaged in the normal way. With the reduction gear locked out, 5th, 6th, 7th and 8th gears are similarly available. Single H or double H shift systems may be fitted.

The Epicyclic Reduction Gear

The epicyclic reduction gear consists of three main components:

An annulus, a sun gear and a planet gear.

The annulus, which is the outer, internally toothed ring gear, is secured to the sliding sleeve of the range change synchroniser assembly.

The sun gear, which is splined and bolted to the transmission mainshaft and runs concentrically with, but independent of the annulus.

The planet gear, which runs in mesh with both the annulus and the sun gear. In this application it consists of a series of five planet gears, running independently on their axes by which they are attached to the planet gear carrier. The carrier is an integral part of the transmission output shaft.

General

The Epicyclic Reduction Gear

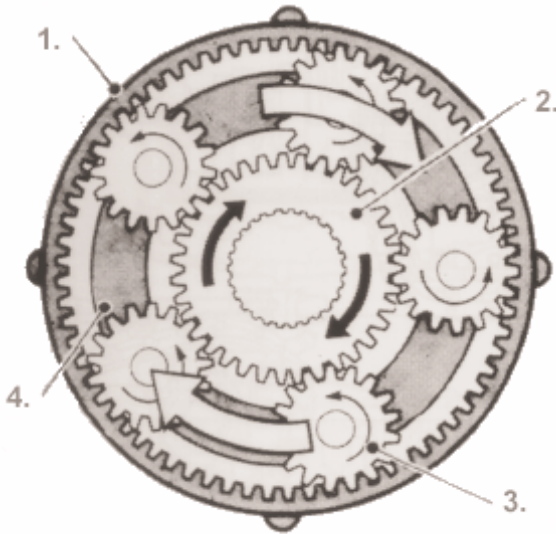

ET-82/1

1. Annulus
2. Sun Gear
3. Planet Gears
4. Planet Gear Carrier

Principle of Operation. If the annulus is held stationary and the sun gear is rotated, the planet gears are driven round the annulus at a speed governed by the size of the sun gear and planet gears relative to the annulus. The planet gears turn on their axes and force the carrier to rotate in the same direction as, but slower than, the sun gear. The output shaft, being an integral part of the carrier rotates with it.

Practical Application. In the Eaton 9-speed transmissions, the 'LOW RANGE' or reduction mode ratio is achieved by sliding the range change synchroniser sleeve and the annulus into mesh with a flange which is secured by a reaction plate to the transmission rear case.

This locks the annulus, and the output shaft therefore rotates in the same direction as, but slower than, the mainshaft.

In the 'HIGH RANGE' or direct drive mode the synchroniser sleeve is slid out of mesh with the reaction plate and into mesh with a flange splined to the planet gear carrier. As the annulus and the planet carrier are now locked together, the planet gears are no longer able to rotate, and the whole epicyclic assembly rotates as a single unit. The

output shaft therefore runs at the same speed as the mainshaft.

With the single H shift system, a manually operated air switch on the gear lever knob engages 'high' or 'low' range as required.

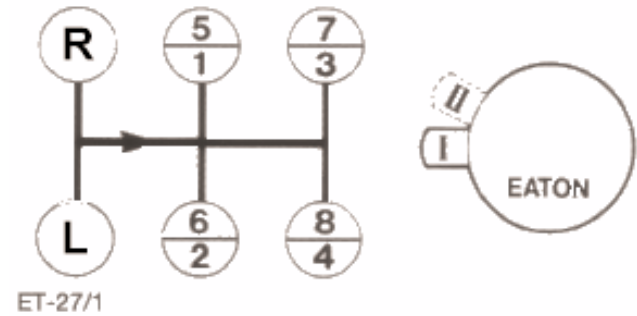

Single H Shift Pattern

An interlock pin between the two selector shafts and an air control valve, fitted to the LRC, prevent the range change operating unless the gear change selector shaft is in the neutral position.

With the double H shift system, a spring loaded detent is placed in the neutral gate between the 3/4 and 5/6 gear positions. As the gear lever is pushed past this detent to the 5th gear position, a slave valve automatically supplies air to shift the range change from low to high. The unique single rail selector mechanism engages 1st, 2nd, 3rd or 4th gears in the main section, but now with the range change in 'high' thus giving 5th, 6th, 7th and 8th gears.

When changing from 5th to 4th, past the detent, the slave valve operates to change from 'high' to 'low' range.

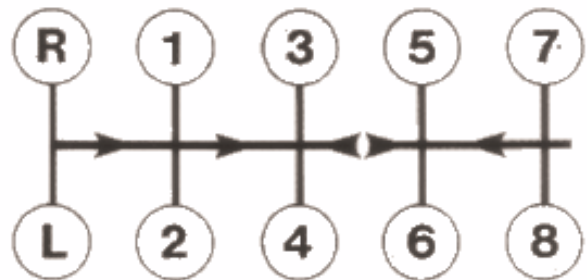

Double H Shift Pattern

Range changes are selected automatically as gear lever is moved over detent.

General

The transmission may be mounted vertically or horizontally and in both positions the gear change remote control may be to the right or the left.

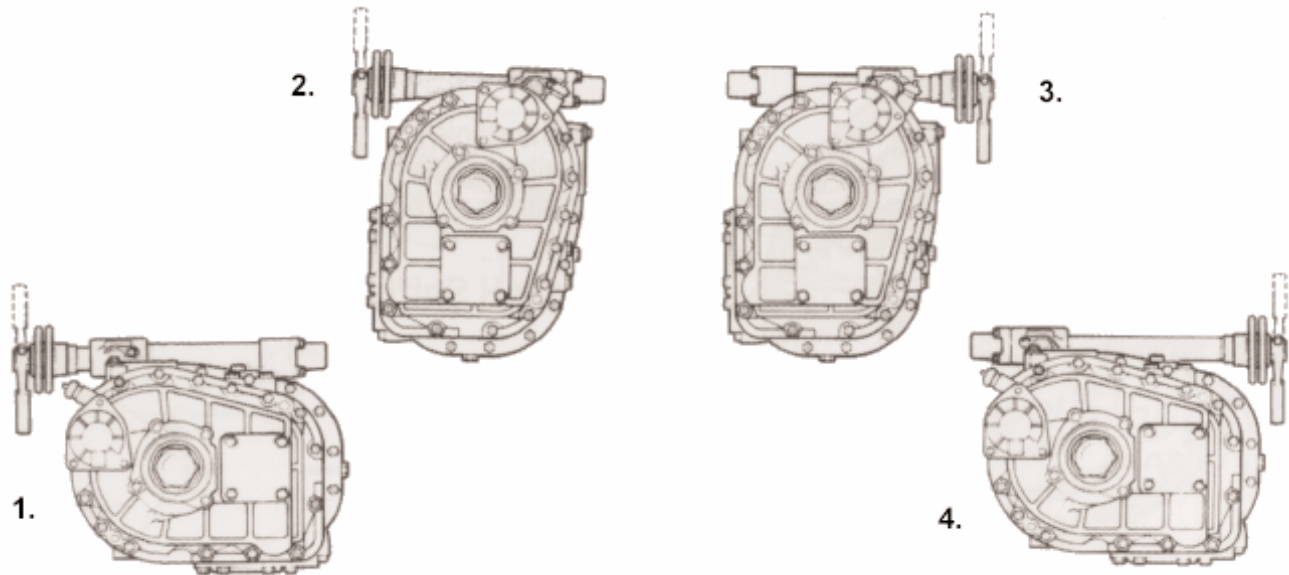

1. Left-hand horizontal 2. Left-hand vertical 3. Right-hand vertical 4. Right-hand horizontal

The synchroniser assemblies are of the baulk ring type with the ring cones manufactured separately from the gears. This allows the synchroniser rings and flanges to be renewed without the need to renew the gears themselves. Reverse gear is engaged by sliding the reverse/low sliding sleeve to engage with the flange on reverse gear but without the assistance of a synchroniser cone.

The transmission is fitted with a pressure fed lubrication system.

The oil is drawn through a strainer in the lower, left-hand side of the transmission by the twin rotor oil pump which is driven directly from the rear of the layshaft. The mainshaft is drilled throughout its entire length and cross drillings take the oil to all the mainshaft bearings, the input shaft bearing and the range change epicyclic planet gear bearings. Transmissions are available with the oil pump and case suitably modified in production to enable an oil cooler to be fitted.

General

Power flow in the gears (direct drive)

R

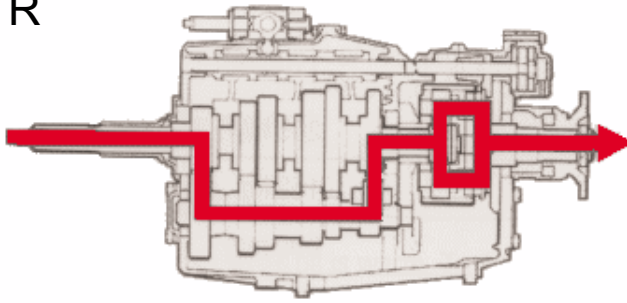

L

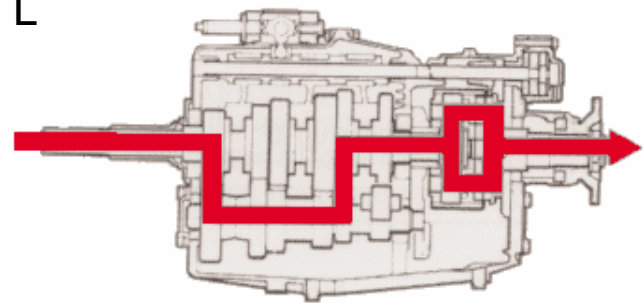

1

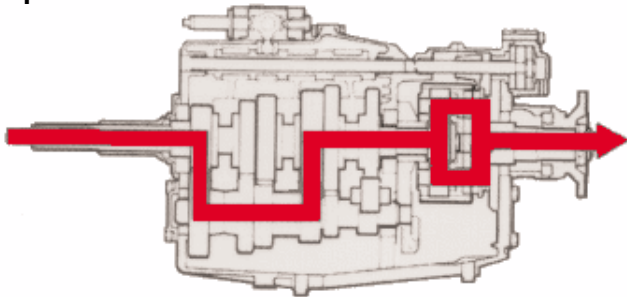

2

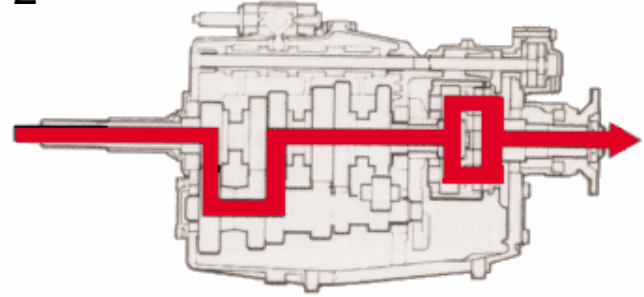

3

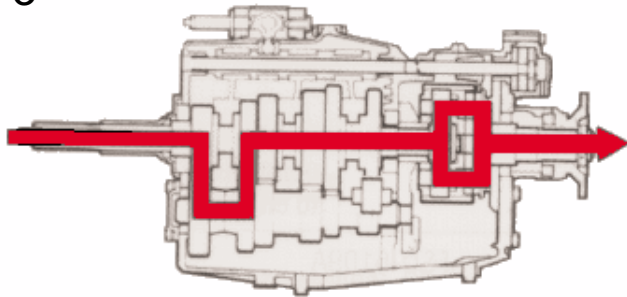

4

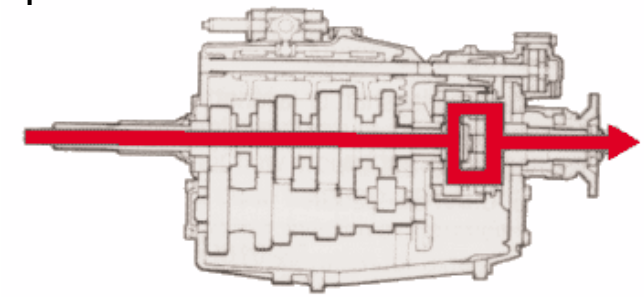

5

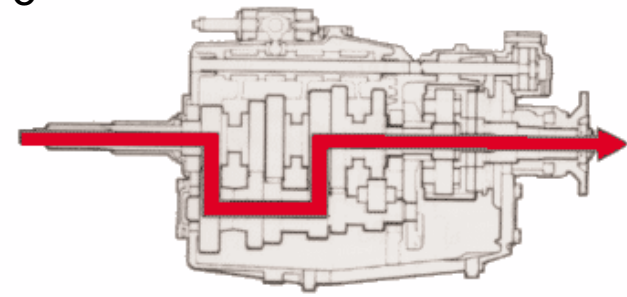

6

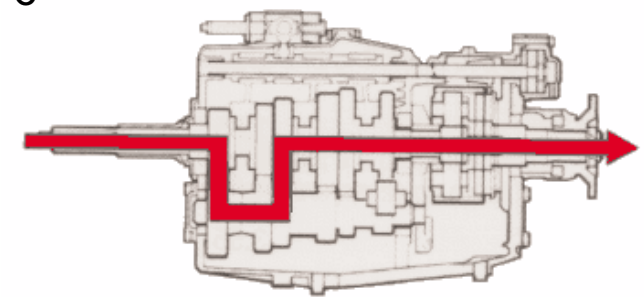

7

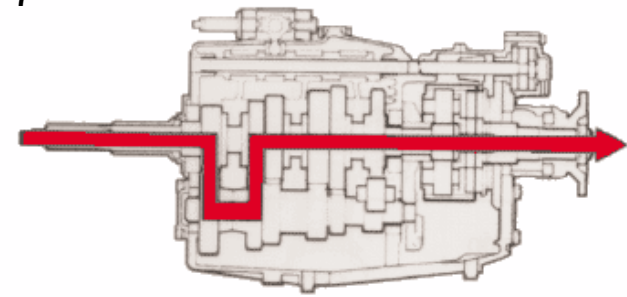

8

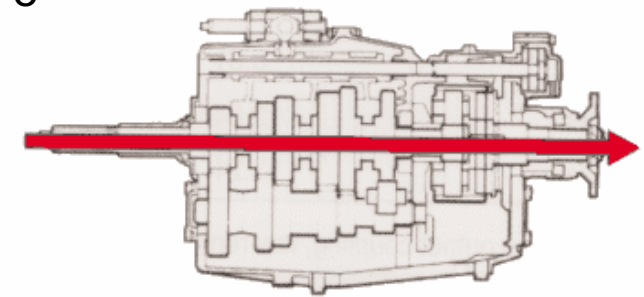

General Specifications

Eaton® FS(O)-6109

Speeds:

9 forward (all synchronised), 1 reverse.

Power Take-off openings:

Left side:

Two standard SAE openings, 6 bolt short length (horizontal mounting)

Bottom two standard SAE openings, 6 bolt short length (vertical mounting)

Extended countershaft PTO Standard.

PTO of gear speeds (% of engine speed):

Left side/bottom PTO's turn at 46% (Overdrive 62%) of engine speed.

On the extended countershaft:
76% (Overdrive 102%) of engine speed.

Speedometer:

Provision in rear bearing cover (standard magn. pick-up).

Reverse light switch:

Provision in maincase for installation of switch.

Neutral switch:

Provision available.

Weight:

Incl output coupling, low remote control
152 kg (365lbs dry).

Oil Capacity:

8.5 litres. (18.5 pints)

Ratios and Steps:

Speed	FS-6109A	FSO-6109A
8	1.00	0.75
7	1.34	1.00
6	1.85	1.38
5	2.48	1.86
4	3.55	2.65
3	4.77	3.55
2	6.55	4.90
1	8.81	6.59
low	12.64	9.45
REV	13.21	9.88

General Specifications

Eaton® FS(O)-6309

Speeds:

9 forward (all synchronised), 1 reverse.

Power Take-off openings:

Left side:

Two standard SAE openings, 6 bolt short length (horizontal mounting)

Bottom two standard SAE openings, 6 bolt short length (vertical mounting)

Extended countershaft PTO Standard.

PTO of gear speeds (% of engine speed):

Left side/bottom PTO's turn at 47% (Overdrive 62%) of engine speed.

On the extended countershaft:
76% (Overdrive 103%) of engine speed.

Speedometer:

Provision in rear bearing cover (standard magn. pick-up).

Reverse light switch:

Provision in maincase for installation of switch.

Neutral switch:

Provision available.

Weight:

Incl output coupling, low remote control
152 kg (365lbs dry).

Oil Capacity:

8.5 litres. (18.5 pints)

Ratios and Steps:

Speed	FS-6309A	FSO-6309A
8	1.00	0.75
7	1.34	1.00
6	1.85	1.38
5	2.48	1.86
4	3.53	2.64
3	4.74	3.53
2	6.52	4.87
1	8.76	6.55
low	12.57	9.40
REV	13.19	9.83

General Specifications

Eaton® FS(O)-8209

Speeds:

9 forward (all synchronised), 1 reverse.

Power Take-off openings:

Left side:

Two standard SAE openings, 6 bolt short length (horizontal mounting)

Bottom two standard SAE openings, 6 bolt short length (vertical mounting)

Extended countershaft PTO Standard.

PTO of gear speeds (% of engine speed):

Left side/bottom PTO's turn at 46% (Overdrive 62%) of engine speed.

On the extended countershaft:
76% (Overdrive 103%) of engine speed.

Speedometer:

Provision in rear bearing cover (standard magn. pick-up).

Reverse light switch:

Provision in maincase for installation of switch.

Neutral switch:

Provision available.

Weight:

Incl output coupling, low remote control
152 kg (365lbs dry).

Oil Capacity:

8.5 litres. (18.5 pints)

Ratios and Steps:

Speed	FS-8209A	FSO-8209A
8	1.00	0.75
7	1.34	1.00
6	1.85	1.38
5	2.48	1.86
4	3.55	2.65
3	4.77	3.55
2	6.55	4.90
1	8.81	6.59
low	12.64	9.45
REV	13.21	9.88

Design features 8209:

Improved box gearing.

CBN ground range clearance.

Increased capacity planet carrier
Shot peened 2nd gear.

11% increase in capacity of layshaft taper bearings.
Non-synchronized crawler (synchronizer is optional).

Range change inhibitor (to help prevent the driver damaging the engine and transmission).

General Specifications

Eaton® FS(O)-8309

Speeds:

8 forward (all synchronised) + 1 crawler (synchronizer optional), 1 reverse.

Power Take-off openings:

Left side:
Two standard SAE openings, 6 bolt short length
Extended countershaft PTO Standard.

PTO of gear speeds (% of engine speed):

Left side/bottom PTO's turn at 47%
(Overdrive 62%) of engine speed.
On the extended countershaft:
76% (Overdrive 103%) of engine speed.

Speedometer:

Provision in rear bearing cover (standard magn. pick-up).

Reverse light switch:

Provision in maincase for installation of switch.

Neutral switch:

Provision available.

Weight:

Incl output coupling, low remote control
152 kg (365lbs dry).

Oil Capacity:

8.5 litres. (18.5 pints)

Ratios and Steps:

Speed	FS-8309A	F5O-8309A
8	1.00	0.75
7	1.34	1.00
6	1.85	1.38
5	2.48	1.86
4	3.53	2.69
3	4.74	3.53
2	6.51	4.81
1	8.76	6.55
low	12.57	9.40
REV	13.14	9.83

Design Features 8309

New gearing components:

Headset gears

High contact ratio [picture 1 below]; improved tooth contact [picture 2 below] enhanced gear mesh for quieter operation and longer life. This noise reduction is one of the aspects of the 8309 that helps it comply with the EURO 3 standards.

Picture 1; contact ratio



Picture 2; tooth contact

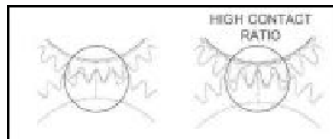

Range gearing:

Fine pitch; number of teeth of annulus, planet gear and sun gear has changed. Overall ratio is about the same (was 3.55, now 3.53)

General

Lubrication

Proper Oil Level

Before checking the oil level or refilling, ensure vehicle is on level ground. Make sure that the oil is level with the filler opening.

Draining Oil

Drain transmission while oil is warm. To drain oil remove the drain plug at the bottom of the case, or remove the strainer from the intermediate case (see below). Clean the drain plug before refitting.

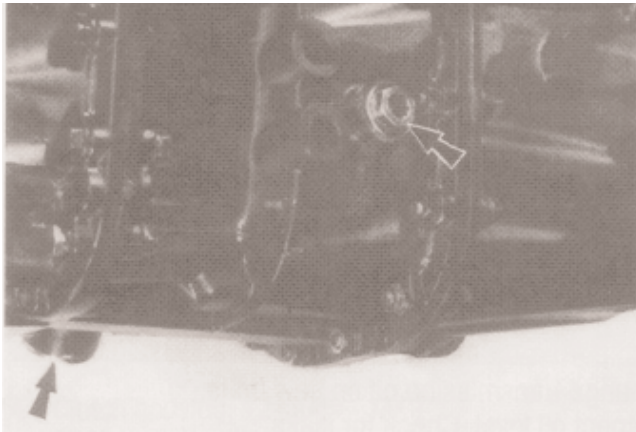

Drain and Filler Plugs

Oil Strainer

Remove and clean the oil strainer. Clean the strainer in kerosene (paraffin) or suitable solvent and dry thoroughly. Renew the washer and the O-ring if necessary. When refitting, tighten to the correct torque (40 to 47 Nm).

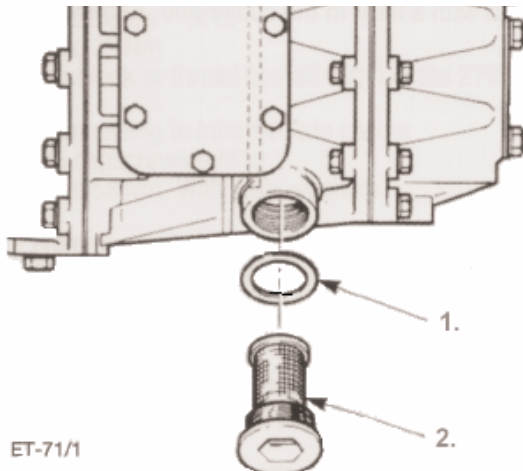

1. Washer 2. Strainer

Refilling

Clean area round filler plug. Fill transmission to the level of the filler opening. The exact amount of oil depends on the transmission inclination. In every instance, fill to the level of the filler opening. Do not overfill - this causes oil to be forced out of the case past the output and input shaft seals.

Adding Oil

It is recommended that different types and brands of oil are not intermixed because of possible incompatibility.

Operating Temperature

It is important that the transmission operating temperature does not exceed 120°C for an extended period of time. Operating temperatures above 120°C cause breakdown of the oil and shorten transmission life. The following conditions in any combination can cause operating temperatures of over 120°C.

1. Operating consistently at road speeds under 32 km/h
2. High engine RPM
3. High ambient temperature
4. Restricted air flow around transmission
5. Exhaust too close to transmission
6. High horsepower, overdrive operation
7. High power PTO operation for extensive periods while stationary.

High operating temperatures may require more frequent oil changes and/or fitment of a cooler.

Towing

When towing the vehicle, the propeller shaft between the axle and transmission must be disconnected.

General

Lubrication recommendations

The growing interest in synthetic and semi-synthetic oils has resulted in some of these products being approved by brand name for extended drain intervals.

The following are the recommended lubricants for Eaton transmissions.

Mineral oils

Lubrication Change and Inspection

On Highway Use

First 5000 to 10,000 km	Change transmission oil on new units at operators discretion
Every 20,000 km	Inspect oil level. Check for leaks
Every 100,000 km or one year	Change transmission oil

Off Highway Use

First 30 hours	Change transmission oil on new units at operators discretion
Every 40 hours	Inspect oil level. Check for leaks
Every 500 hours	Change transmission oil where severe dirt conditions exist
Every 1,000 hours	Change transmission oil (Normal off-highway use)

Recommended Lubricants

Type Grade (SAE) Ambient Temperature

Heavy Duty	50	Above - 12°C
Engine oil API -	40	Above - 12°C
CD	30	Below - 12°C
Mild EP Gear Oil	90	-12°C to 38°C
API-GL-4	80W	-26°C to 21°C

Caution

- Multi-viscosity engine oils (such as 15W40) are not recommended without consultation with Eaton
- Do not mix engine oils and gear oils in the same transmission.
- Eaton does not approve mineral oil lubricants by brand name.
- Additives or friction modifiers which are not part of the original lubricant are not recommended.

Synthetic and semi-synthetic oils

Synthetic oils

The following three brands of synthetic oils are now approved for use in Eaton transmissions;

1. COGNIS (HENKEL/EMERY) MTF 4200
2. CASTROL SYNTRANS
3. MOBILUBE 1 SHC

General

Recommended lubricants

Lubrication Change and Inspection – Synthetic oils

On Highway Use

All brands -
Every 20,000 km

Inspect oil level. Check for leaks

COGNIS (HENKEL/EMERY) MTF 4200
Every 500,000 Km or three years

Change transmission oil

CASTROL SYNTRANS
Every 400,000 Km or three years

Change transmission oil

MOBILUBE 1 SHC

Change transmission oil

Every 300,000 Km or three years

Off Highway Use

All brands
Every 40 hours

Inspect oil level. Check for leaks

All brands
Every 500 hours

Change transmission oil where severe dirt conditions exist

All brands
Every three years

Change transmission oil (Normal off-highway use)

Semi-Synthetics

The following nine brands of semi-synthetic oils are now approved for use in Eaton transmissions ;

1. ELF TRANSELF 75W80W, (also known as RVI Longevia)
2. MOBIL MOBILUBEXHP
3. KUWAIT Q8 T 60
4. FUCHS DEA DEAGEAR LD & TITAN CYTRAC LD
5. FIAT LUBRIFICANTI TUTELA TRUCK GEAR FE
6. DE OLIEBRON TOR MT/LD GEAR OIL
7. OMV AKTIENGESELLCHAFT OMVLDL 75W-80
8. PAKELO MOTOR OIL PAKELO GOLDENGEAR LD
9. TEXACO MULTIGEAR MTF 75W80W

Lubrication Change and Inspection – Semi -synthetic oils

On Highway Use

All brands
Every 20,000 km

Inspect oil level. Check for leaks

Every 300,000 Km or three years

Change transmission oil

Off Highway Use

All brands
Every 40 hours

Inspect oil level. Check for leaks

Every 500 hours

Change transmission oil where severe dirt conditions exist

Every three years

Change transmission oil (Normal off-highway use)

General

Torque tightening recommendations

Vertical installation

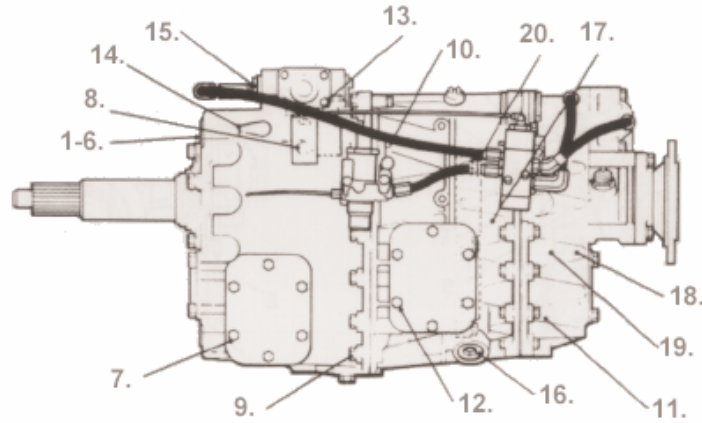

1. Clutch Housing,

10 studs - M18
81 Nm minimum.
Installed with Loctite 242

2. Clutch housing,

10 nuts - M18
190 to 203 Nm
With plain washers and lockwashers

3. Clutch housing,

10 capscrews - M18
190 to 203 Nm
With plain washers and lockwashers

4. Clutch housing,

12 studs - M12
59 Nm minimum
Installed with plain washers and lockwashers

5. Clutch housing,

12 nuts - M12
70 to 80 Nm
With plain washers and lockwashers

6. Clutch housing,

12 capscrews - M12
70 to 80 Nm
With plain washers and lockwashers

7. Front PTO cover,

6 capscrews - M10
35 to 39 Nm

8. Selector block tapered lock screw,

1 lock screw - M10
35 to 39 Nm
Patchlock or thread coated with Loctite 270

9. Front casing to intermediate casing,

Plain capscrews with washers - fastened directly to the case
51 to 58Nm.
Flange headed fasteners (no washers) - fastened directly to the case
30 to 40Nm

10. Front casing to intermediate casing,

Plain capscrews with washers and nuts
51 to 58Nm
Flange headed fasteners and nuts (no washers)
45 to 55Nm

11. Rear casing to intermediate casing,

Plain capscrews with washers and nuts ~ 51 to 58Nm
Flange headed fasteners and nuts (no washers) ~ 45 to 55Nm

12. PTO/Reverse idler gear cover,

6 capscrews - M10
35 to 39 Nm

13. Remote control housing end cover,

4 capscrews - M8
20 to 24 Nm
With lockwashers

14. Overdrive selector fork pivot pins,

2 capscrews - M8
20 to 24 Nm
With lockwashers

15. Slave valve - double H shift,

2 socket headed capscrews - M6
20 to 24 Nm
With lockwashers

Slave valve - single H shift,

2 capscrews - M6
20 to 24 Nm
With lockwashers

Exhaust valve - single H shift,

2 capscrews - M16
16 to 22 Nm

16. Oil strainer,

M40 x 1.5 thread
40 to 47 Nm

17. Sun gear retaining cap screw,

M16
225 to 255 Nm
Use new patchlock coated cap screw

18. Reaction plate,

4 socket headed countersunk screws - M8
24 to 27 Nm

19. Planet gear spindles,

5 socket head locating grub screws - M6
5 to 8 Nm
New grub screw thread coated with Loctite 270

20. Oil pump,

8 capscrews - M10
35 to 40 Nm
With plain washers

General

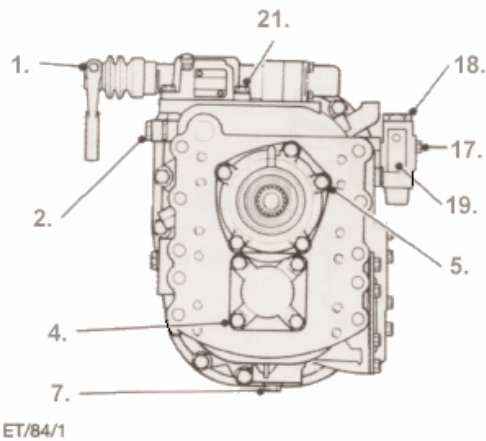

1. Remote control shift lever

1 capscrew and nut - M8

20 to 27 Nm

With lockwasher

or 1 capscrew and nut - M10

35 to 39 Nm

With lockwasher

2. Selector shaft detent cover,

2 capscrews - M8

20 to 24 Nm

With lockwashers

3. Oil filler plug,

M24

32 to 37 Nm

4. Layshaft front bearing cover,

4 capscrews - M12

69 to 78 Nm

With lockwashers

5. Input shaft front bearing cover,

3 capscrews - M10

35 to 39 Nm

With lockwashers

6. Remote control housing detent cover,

2 capscrews - M8

20 to 24 Nm

With lockwashers

7. Oil drain plug (magnetic),

M24

32 to 37 Nm

8. Speedometer pinion adaptor,

M22

20 to 27 Nm

Copper washer

9. Speedometer housing,

4 capscrews - M10

35 to 39 Nm

With plain washers and lockwashers

10. Rear case cover (rear PTO),

4 capscrews - M12

69 to 78 Nm

With lockwashers

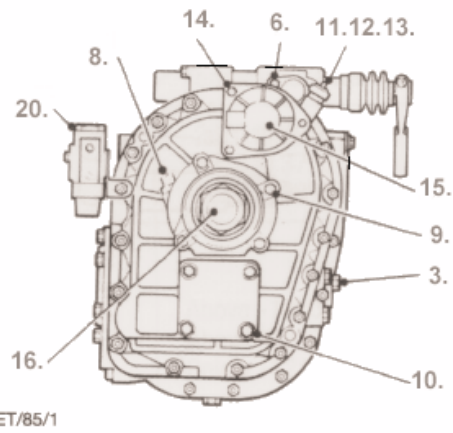

ET/85/1

11. Reverse lamp switch,

M16

16 to 22 Nm

12. Range indicator lamp switch,

M16

16 to 22 Nm

13. Neutral switch,

M16

16 to 22 Nm

14. Range change cylinder cover,

3 capscrews - M8

20 to 24 Nm

With plain washers and lockwashers

15. Range change piston nut,

M16

95 to 115 Nm

16. Output shaft,

locknut - M39

600 to 700 Nm

With nylon locking insert

17. Air filter/pressure regulator,

2 capscrews - M6

10 to 16 Nm

With lockwashers

18. Air filter cap,

1 1/4" M18

23 to 28.5 Nm

19. Air connections,

1/8" NPFT

7 to 10 Nm

20. Air supply,

3/8" NPFT

10 to 14 Nm

21. Remote control housing,

4/6/8 capscrews - M10

35 to 39 Nm

Loctite 242

General Horizontal installation

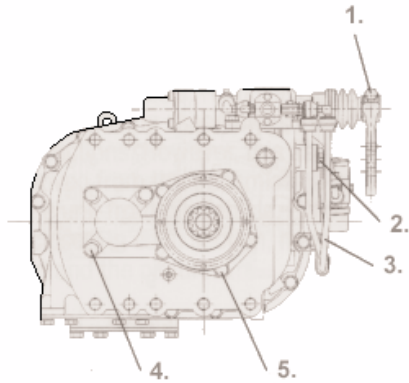

1. Remote control shift lever

1 capscrew and nut - M8
20 to 27 Nm
With lockwasher
or 1 capscrew and nut - M10
35 to 39 Nm
With lockwasher

2. Selector shaft detent cover,

2 capscrews - M8
20 to 24 Nm
With lockwashers

3. Oil filler plug,

M24
32 to 37 Nm

4. Layshaft front bearing cover,

4 capscrews - M12
69 to 78 Nm
With lockwashers

5. Input shaft front bearing cover,

3 capscrews - M10
35 to 39 Nm
With lockwashers

6. Remote control housing detent cover,

2 capscrews - M8
20 to 24 Nm
With lockwashers

7. Oil drain plug (magnetic),

M24
32 to 37 Nm

8. Speedometer pinion adaptor,

M22
20 to 27 Nm
Copper washer

9. Speedometer housing,

4 capscrews - M10
35 to 39 Nm
With plain washers and lockwashers

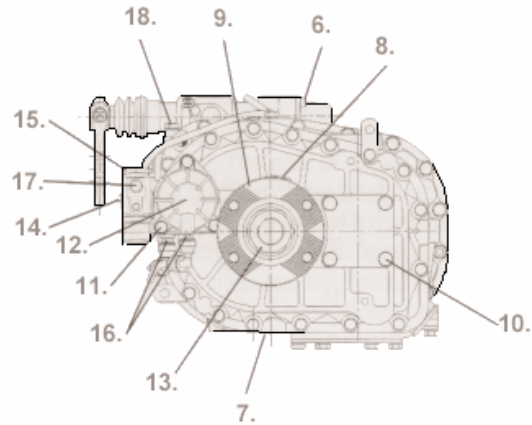

10. Rear case cover (rear PTO),

4 capscrews - M12
69 to 78 Nm
With lockwashers

11. Range change cylinder cover,

3 capscrews - M8
20 to 24 Nm
With plain washers and lockwashers

12. Range change piston nut,

M16
95 to 115 Nm

13. Output shaft,

locknut - M39
600 to 700 Nm
With nylon locking insert

14. Air filter/pressure regulator,

2 capscrews - M6
10 to 16 Nm
With lockwashers

15. Air filter cap,

1 1/4" M18
23 to 28.5 Nm

16. Air connections,

1/8" NPFT
7 to 10 Nm

17. Air supply,

3/8" NPFT
10 to 14 Nm

18. Remote control housing,

4/6/8 capscrews - M10
35 to 39 Nm
Loctite 242

General

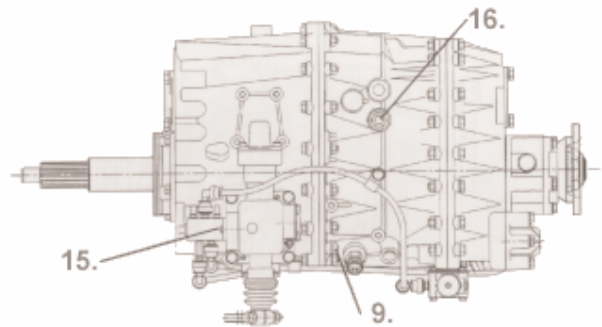
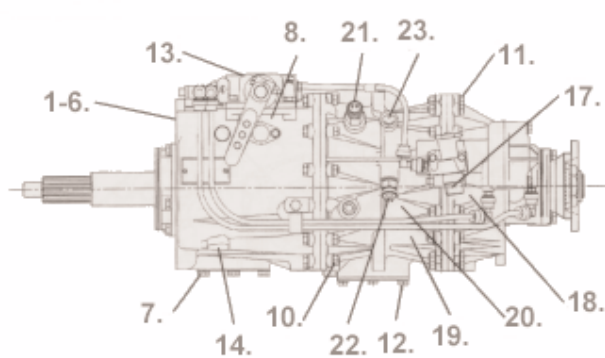

1. Clutch Housing,

10 studs - M18
81 Nm minimum
Installed with Loctite 242

2. Clutch housing,

10 nuts - M18
190 to 203 Nm
With plain washers and lockwashers

3. Clutch housing,

10 capscrews - M18
190 to 203 Nm
With plain washers and lockwashers

4. Clutch housing,

12 studs - M12
59 Nm minimum
Installed with plain washers and lockwashers

5. Clutch housing,

12 nuts - M12
70 to 80 Nm
With plain washers and lockwashers

6. Clutch housing,

12 capscrews - M12
70 to 80 Nm
With plain washers and lockwashers

7. Front PTO cover,

6 capscrews - M10
35 to 39 Nm

8. Selector block tapered lockscrew,

1 lockscrew - M10
35 to 39 Nm
Patchlock or thread coated with Loctite 270

9. Front casing to intermediate casing,

Plain capscrews with washers - fastened directly to the case
51 to 58Nm.
Flange headed fasteners (no washers) - fastened directly to the case
30 to 40Nm

10. Front casing to intermediate casing,

Plain capscrews with washers and nuts
51 to 58Nm
Flange headed fasteners and nuts (no washers)
45 to 55Nm

11. Rear casing to intermediate casing,

Plain capscrews with washers and nuts
51 to 58Nm
Flange headed fasteners and nuts (no washers)
45 to 55Nm

12. PTO/Reverse idler gear cover,

6 capscrews - M10
35 to 39 Nm

13. Remote control housing end cover

4 capscrews - M8
20 to 24 Nm
With lockwashers

14. Overdrive selector fork pivot pins

2 capscrews - M8
20 to 24 Nm
With lockwashers

15. Slave valve - double H shift

2 socket headed capscrews - M6
20 to 24 Nm

Slave valve - single H shift,

2 capscrews - M6
20 to 24 Nm
With lockwashers

Exhaust valve - single H shift,

2 capscrews - M16
16 to 22 Nm

16. Oil strainer,

M40 x 1.5 thread
40 to 47 Nm

17. Sun gear retaining capscrew

M16
225 to 255 Nm
Use new patchlock coated capscrew

18. Reaction plate,

4 socket headed countersunk screws - M8
24 to 27 Nm

19. Planet gear spindles

5 socket head locating grub screws - M6
5 to 8 Nm
New grubscrew thread coated with Loctite 270

20. Oil pump,

8 capscrews - M10
35 to 40 Nm
With plain washers

21. Reverse lamp switch

M16
16 to 22 Nm

22. Range indicator lamp switch

M16
16 to 22 Nm

23. Neutral switch

M16
16 to 22 Nm

General

Disassembly precautions

It is assumed in the detailed disassembly instructions that the lubricant has been drained and the necessary linkage and air lines have been removed from the chassis. Removal of the gear shift remote control housing assembly is included in the detailed instructions. However, this assembly may also be removed from the transmission before removing the unit from the vehicle. Follow each procedure closely in each section, making use of both the text and the pictures.

1. Cleanliness - Provide a clean place to work. It is important that no dirt or foreign material enters the unit during repairs. The outside of the unit should be carefully cleaned before starting the disassembly. Dirt is abrasive and can damage bearings.

2. Assemblies - When disassembling the various assemblies, such as the mainshaft, range change epicyclic, layshaft and remote control housing, place all parts on a clean bench in the same sequence as removed. This procedure will simplify reassembly and reduce the possibility of losing parts. When pulling off synchroniser hubs follow the procedures detailed in 'Disassembly' using a suitable press of adequate capacity. Failure to adhere to the recommended procedures may cause irreparable damage.

3. Snap rings - Remove snap rings with pliers designed for this purpose. New selective fit snap rings must be fitted as specified in "Reassembly".

4. Input shaft - The input shaft (Direct drive version only) can be removed without removing the layshaft or mainshaft. Take care not to misplace or lose the mainshaft spigot bearing.

5. Bearings - Carefully wash and re-lubricate all bearings as removed and protectively wrap until ready for use. Remove bearings with pullers designed for this purpose.

6. When pressing - Apply force to shafts, housings etc. with restraint. Movement of some parts is restricted. Do not apply force after the part being driven stops solidly. Use soft hammers for all disassembly work. Do not use pry bars or chisels to separate casing halves and housings or irreparable damage may be caused.

Inspection of expendable parts

Before reassembling the transmission, the individual parts should be carefully checked and any that are damaged should be rejected. These should be renewed. This inspection procedure should be carefully followed to ensure the maximum wear life from the rebuilt unit. The cost of a new part is generally a small fraction of the total cost of downtime and labour. The use of a questionable part may make additional repairs necessary before the next regularly scheduled overhaul. Recommended inspection procedures are set forth in the following check list:

A. Bearings

1. Wash all bearings in clean solvent. Check rollers and races for pits and spalled areas. Renew damaged bearings.

2. Lubricate undamaged bearings and check for axial and radial clearances. Renew bearings with excessive clearances.

3. Check fits of bearings in housing bores. If outer races turn too freely in the bores, the housing should be renewed. Check housing bores for signs of wear prior to taking this action. Renew housing if wear is seen as a result of bearing spin (see Item L).

4. Planet gear bearings consist of two tracks of 18 loose assembled rollers, i.e. 36 rollers per gear, separated by a spacer. If any rollers in a gear set are worn or damaged the whole set must be renewed.

B. Gears

1. Check gear teeth for pitting of the tooth faces. Gears with pitted teeth should be renewed.

2. Check the internal bearing surfaces for wear or the effects of overheating.

3. Check axial clearances of gears. Where excessive clearance is found, check gear, ring and hub for excessive wear. Maintain the specified axial clearance on mainshaft forward gears.

C. Bearing Sleeve - Mainshaft

1. Sleeves with groove formation, pits or which

General

have either been overheated or worn out must be renewed.

D. Synchroniser Assemblies

1. Check to ensure all splines are free from excessive wear.
2. Check that the engagement dog teeth on the sliding sleeves, synchroniser flanges and synchroniser rings are free from chipping and burring.
3. Check that the synchroniser ring cones are not excessively worn or showing the effects of overheating. Check the clearance between the synchroniser ring and the synchroniser flange is between 1.9mm and 0.5mm for molybdenum coated synchronisers and between 3.01mm and 0.5mm for pyrolitic synchronisers.
4. Renew the springs, plungers and rollers.

E. Splines

1. Check splines on all shafts for wear. If synchroniser hubs, output drive flange or clutch hub have worn into the sides of the splines, the shafts in this condition must be renewed.

F. Thrust Washers

1. Check surfaces of all thrust washers. Washers scored, burnt or reduced in thickness should be renewed.

G. Range Change Planet Gears, Spindles and Needle Roller Bearings

1. If it is found necessary to dismantle the planet gears, retain each gear, spindle, rollers, spacers and washers in their respective set for reassembly in the same relative positions.
2. If uneven wear is found in the planet gears, check lubrication holes for blockage and renew all rollers.
3. Renew planet spindle grub screws on reassembly.

H. Reverse Idler Gear

1. Check bearings and shaft for wear from action of roller bearings.

I. Clutch Release Parts

1. Check clutch release parts, yokes and bearing

carrier. Check pedal shafts. Renew worn shafts and bearings.

J. Gear Selector Shaft Assembly

1. Check forks and keys for wear at contact points. Renew worn parts.
2. Check forks for alignment.
3. Check forks for excessive wear, renew worn forks.
4. Check lockscrew in selector block. A lockscrew with worn taper must be renewed.
5. Check condition and fit of selector key and interlock key in selector shaft. Worn or damaged keys must be renewed.

K. Gear Shift Remote Control

1. Check spring tension on cross shaft. Renew tension springs if shaft moves too freely.
2. If housing is dismantled, check cross shaft and inner lever and the bearing bushes for wear. Renew worn parts.
3. Check all seals and locating journals. Renew worn parts.

L. Bearing Covers

1. Check covers for wear from thrust. Renew covers worn or grooved from thrust of bearing outer race.
2. Check bores of covers for wear. Renew those worn oversize.

M. Oil Return Threads and Seals

1. Check oil seal in front bearing cover for damage and wear, renew if necessary.
2. Check oil seal in speedometer housing for damage or wear, renew if necessary.
3. Check oil seal tracks for wear and renew if worn or grooved.
4. Check the oil sealing rings in the muff ring for wear or breakage.

N. O-Rings

1. Renew all O-rings.

O. Oil Pump

Check the oil pump rotors and covers for scoring and wear. The complete pump assembly must be renewed if scored or excessively worn, or its serviceability is suspect in any way.

General

Reassembly precautions

Make sure that interiors of all housings are clean. It is important that dirt be kept out of transmission during reassembly. Dirt is abrasive and can damage polished surfaces of bearings and washers. Use certain precautions, as listed below, during reassembly.

1. Gaskets - Use new gaskets where detailed only (neutral detent and remote control housing covers). All other locations, ensure mating faces are clean and undamaged and apply a continuous bead of Loctite 5900 Flange Sealant to one face only. Do not apply excessive sealant or allow it to penetrate into the bearings.

2. Capscrews - Use thread sealant on all capscrews. The corresponding torque ratings are to be found in 'Torque Tightening Recommendations'.

3. O-Rings - Lubricate all O-rings lightly with silicone lubricant.

4. Initial Lubrication - Lubricate bearings with gearbox oil during reassembly.

5. Axial Clearances - Maintain the end float of mainshaft gears as detailed in the chart on the following page.

6. Bearings - Use of the correct special tools and bearing drivers is recommended for the installation of bearings. Heating the bearing inner tracks where instructed will aid installation.

7. Output Shaft Drive Flange - Tighten the nut to the correct torque.

Do not under any circumstances use an impact wrench to tighten the flange/yoke nut. Use only a hand operated torque wrench or a stall torque motor. Failure to carry out these instructions can cause damage to the locking medium of the nut.

During disassembly and again during reassembly prior to tightening the new nut, it is important to ensure that the output shaft does not slide through the bearing, or the assembled range change synchroniser roller, plungers and springs may be displaced.

A suitable spacer should be temporarily assembled under the nut to allow for the thickness of the nut

locking insert to ensure the shaft is firmly held in the bearing until the nut can be torque tightened.

8a. Synchroniser Hubs - All synchroniser hubs are an interference fit on the mainshaft splines and must be heated to approximately 85°C before installation. Press fully home and hold under pressure for a short period to prevent creep while cooling.

8b. - All synchroniser flanges to be lubricated before assembly.

9. Layshaft - The shaft is only available as a complete assembly for service.

General

Gear End Floats - All dimensions in mm

Gear	3rd	2nd	1st	Low	Reverse
Low Limit	0.31	0.35	0.35	0.35	0.27
High Limit	0.53	0.48	0.48	0.48	0.44
Range	0.22	0.13	0.13	0.13	0.17

Synchroniser Ring to Synchroniser Flange Clearance

Mainshaft Gears	Molybdenum	Pyrolitic carbon
- Minimum	0.50	0.50
- Maximum	1.90	3.01
Range Change		
- Minimum	0.50	0.50
- Maximum	1.90	3.01

Oil Muff Sealing Ring Clearance

- Minimum	0.178
-----------	-------

Oil Pump Rotor Clearance

- Outer Rotor to Pump Body	0.50 (maximum)
- Inner to Outer Pump Lobes	0.50 (maximum)

General

Special tools

Some illustrations show the use of specialised tools. These tools are recommended for disassembly and reassembly of the transmission. They make repair easier, faster and prevent damage.

The following tools are available from SPX UK (Ltd) Tel : +44 (0)1327 303400

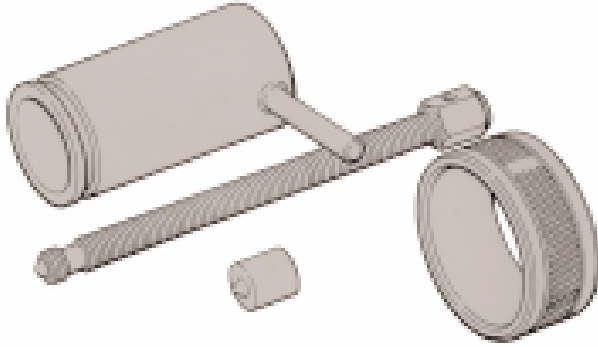

LC 105A Bearing remover.

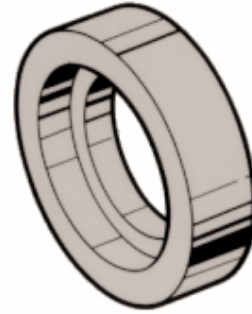

E 108-5 Replacer adaptor for auxiliary counter shaft bearing and input bearing. Use with E 108.

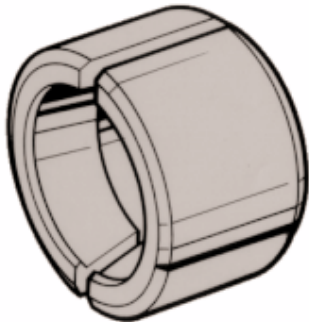

E 105-4 Countershaft bearing remover. Use with LC 105A.

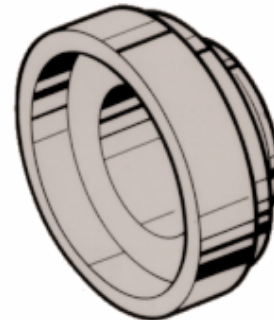

E 108-6 Mainshaft rear seal replacer adaptor.

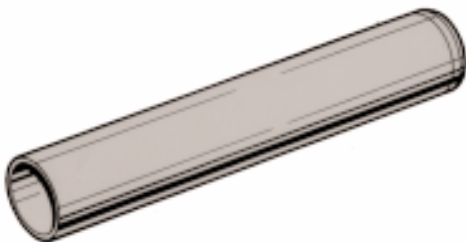

E 108 Driver.

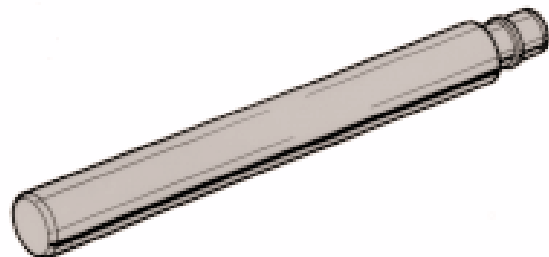

E 109 Driver

General

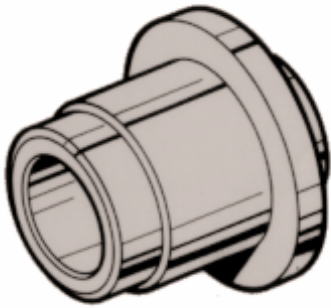

E 109-5 Selector control seal and bush installer.
Use with E 109

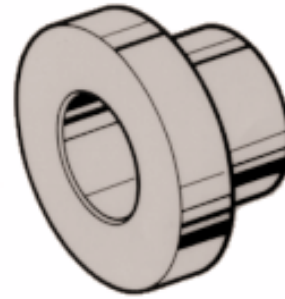

E 109-8 Selector shaft bush installer adaptor. Use
with E 109.

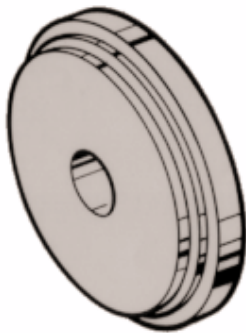

E 109-6 Countershaft bearing cup installer adaptor.
Use with E 109.

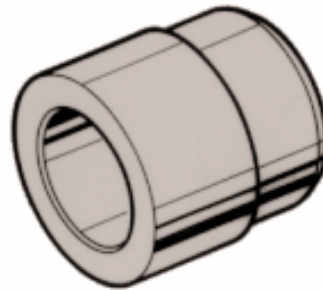

E 109-9 Selector shaft plug installer adaptor. Use
with E 109.

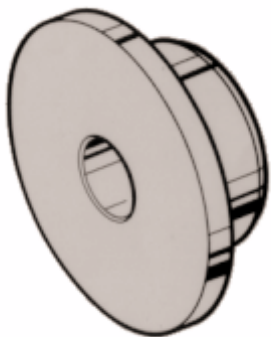

E 109-7 Input shaft seal installer adaptor. Use with
E 109.

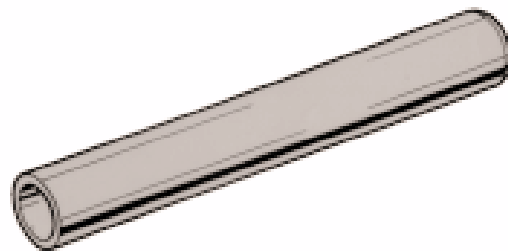

E 109-10 Driver extension. Use with E 109.

General

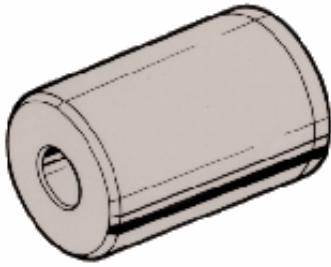

E 109-11 Countershaft bearing cone installer. Use with E 109.

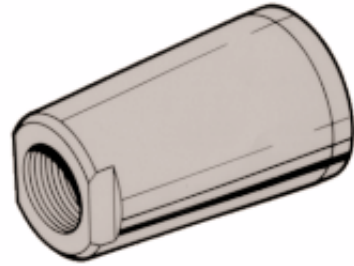

E 114 Rear mainshaft bearing pilot.

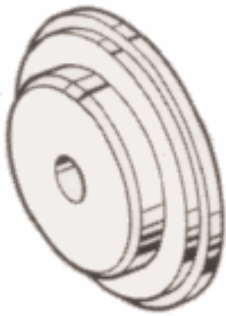

E 109-12 Rear cover oil seal installer. Use with E 109.

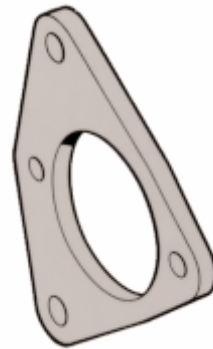

E 115 Flange holding adaptor plate.

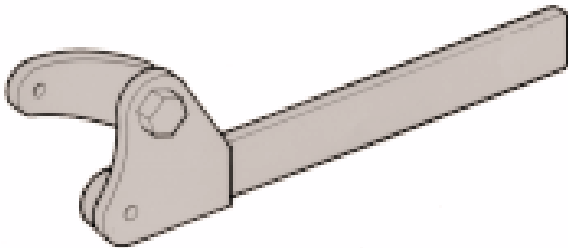

LC 113A Flange holding wrench.

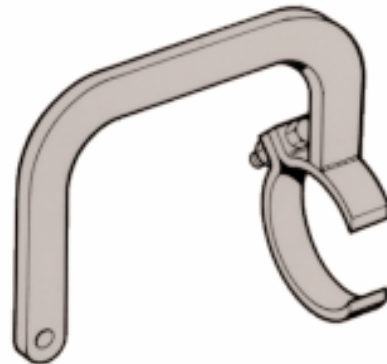

E 116A Gear assembly lifting fixture.

General



E 116-1 Adaptor gear assembly lifting fixture. Use with E 116.

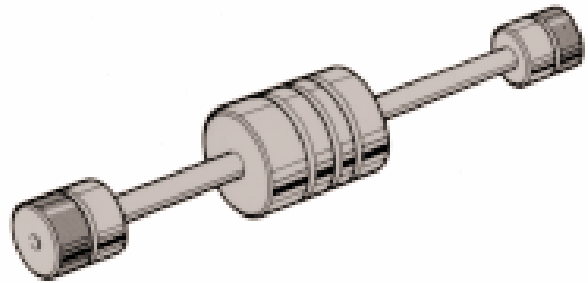

MS 284 Slide hammer.

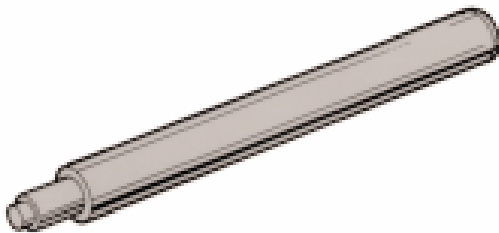

E 117 Reverse idler shaft retaining pin installer.

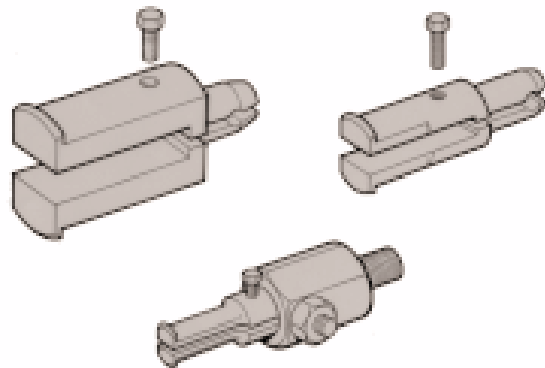

MS 284-1 Extractor set - bearing/bush.

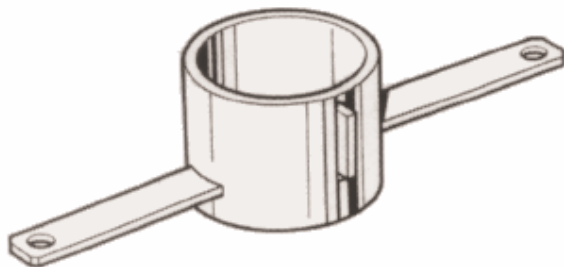

E 118A Sun gear retainer.

General

Locally made tools

All dimensions in mm

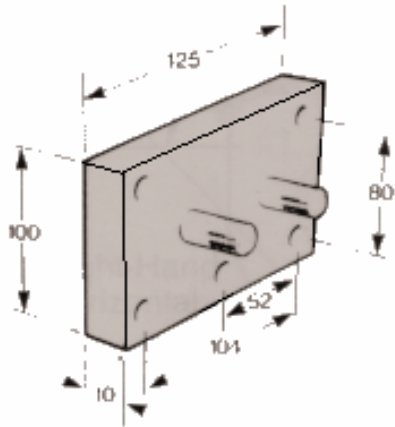

Mounting plates - 2 off.

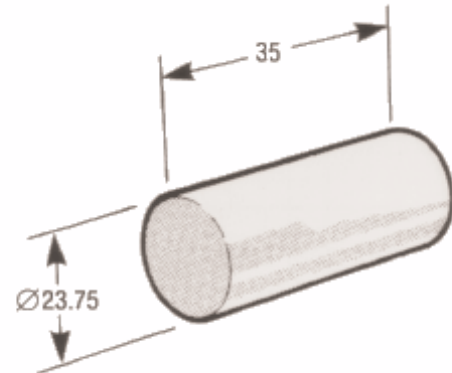

ET-31

Dummy planet gear spindle.

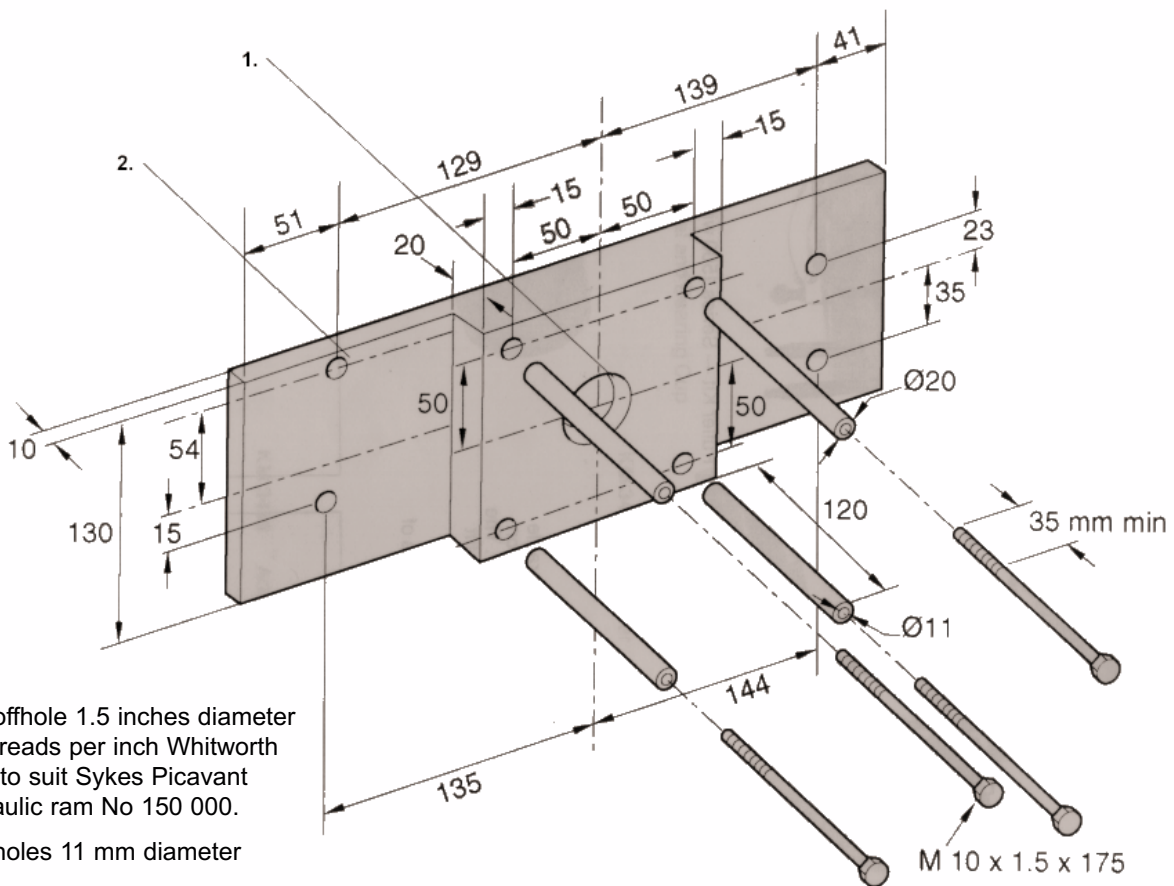

Tool for ball bearing removal.

Section 2 Air System

Air System

General description

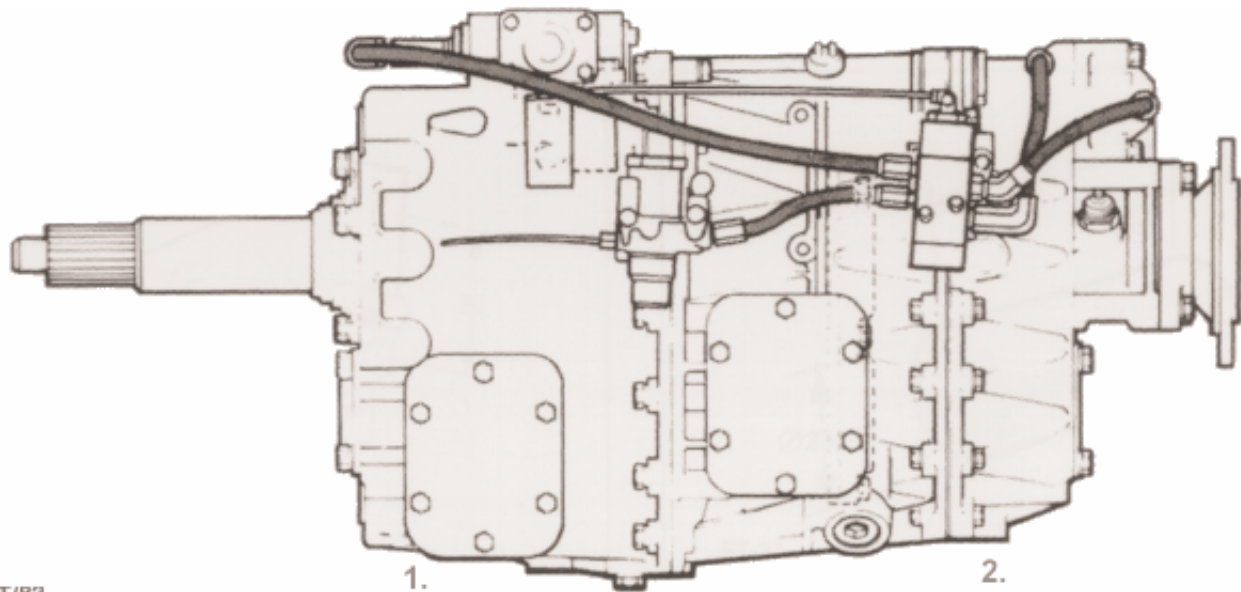

1. Main section

2. Range change section

The Eaton nine-speed synchromesh transmissions consist of a four-speed plus low (crawler) gear and reverse gear main section, and an auxiliary, two-speed range change section. This provides either a direct drive 'high' range or 'low' range output through the medium of an epicyclic reduction gear.

All the forward gears in the main section have synchromesh engagement and are manually selected and engaged. The range change also has synchromesh engagement and is air operated. A shift cylinder, mounted in the rear transmission case, slides a synchroniser sleeve, which forms an integral part of the epicyclic annulus gear, into or out of mesh with the planet gear carrier or a reaction plate in the case giving high or low ratio accordingly.

Air to the high and low range ports on the shift cylinder is supplied via a slave valve. This is activated directly by the remote control shaft on the double H shift system, or by a manually operated

selector valve in the gear lever knob on the single H shift system.

With the single H shift system, 'high' or 'low' range should be pre-selected before the gear lever is moved, the actual range change taking place only when the selector shaft is moved through the neutral position.

An air control valve works in conjunction with the interlock mechanism to prevent the range change operating prematurely after pre-selection.

With the double H shift system the range change is activated automatically as the gear lever is moved across a detent in the neutral gate between the 3/4 and 5/6 gear lever positions.

Air system

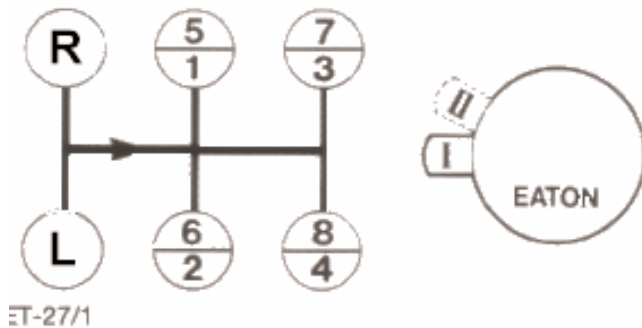

Single H shift

I = Low range II = High range

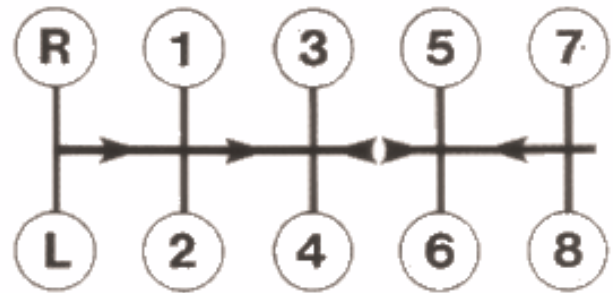

Double H Shift

Air system maintenance

In order to ensure that the transmission functions without problems and has a long life, the compressed air reservoirs on the vehicle must be drained regularly* and the filter on the transmission cleaned every 80,000 km (or 6 months).

*Please consult the Operating Instructions supplied by the vehicle manufacturer.

Air system

Range change shift air lines

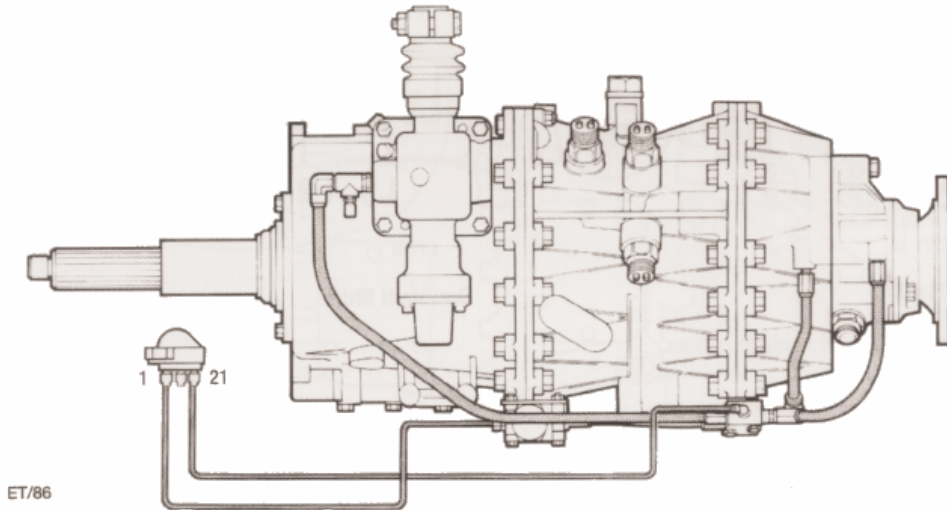

Single H shift gear change air line connections

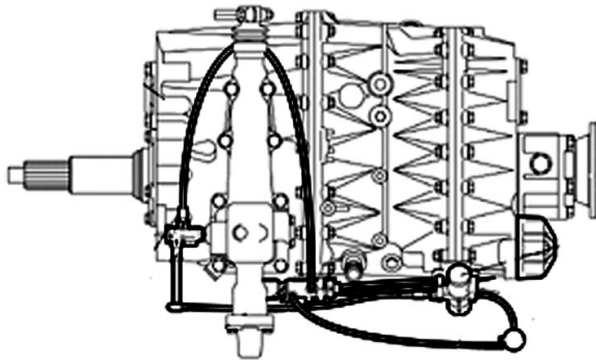

Single H shift gear change air line connections - Mecman

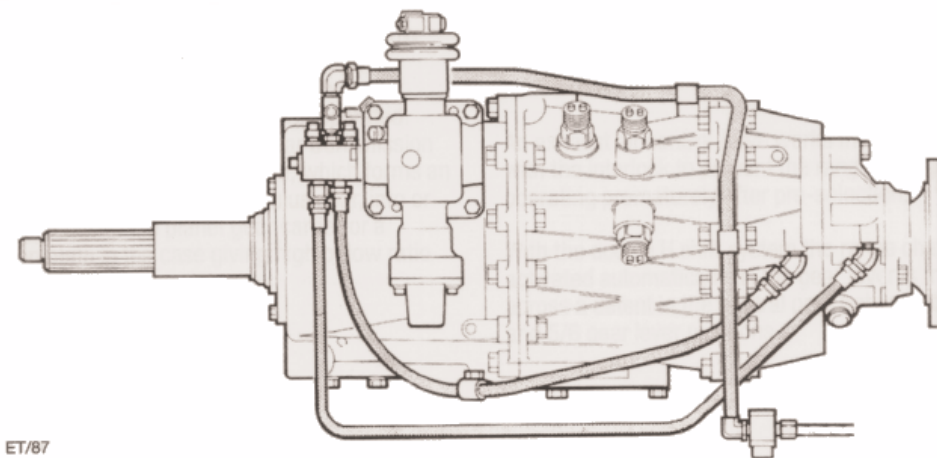

Double H shift gear change air line connections

Air system

Filter pressure regulator

Filter maintenance

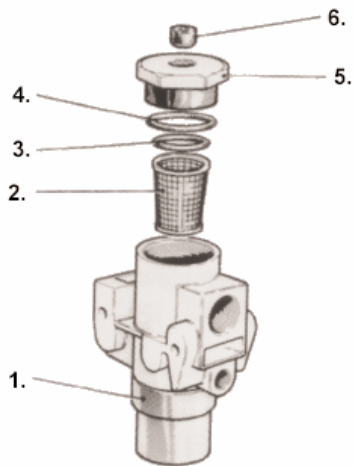

1. Filter pressure regulator
2. Filter element
3. Seal ring
4. O-ring
5. End cap
6. Plug

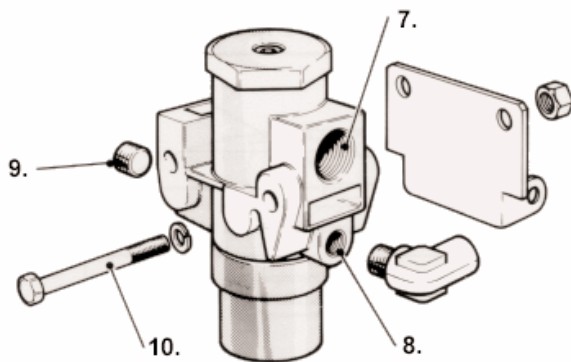

7. Air supply port
 8. Outlet port *
 9. Outlet seal plug *
 10. Capscrew with lockwasher
- * Alternative positions

Removal and disassembly

1. Remove end cap.
2. Remove filter insert from housing and clean. Cleaner: Soap and water solution, cold cleaner etc. then blow element from inside using compressed air.
3. Clean filter regulator housing.

Assembly and installation

1. Renew filter element, seal ring and O-ring if necessary.
2. Fit end cap, tighten to the correct torque.
3. Check filter regulator function. Unscrew seal plug (9), attach test connection with gauge. Recommended operating pressure 5.34 to 5.69 bar.

Mecman Regulator

Filter regulator as used on later models. This component is non serviceable

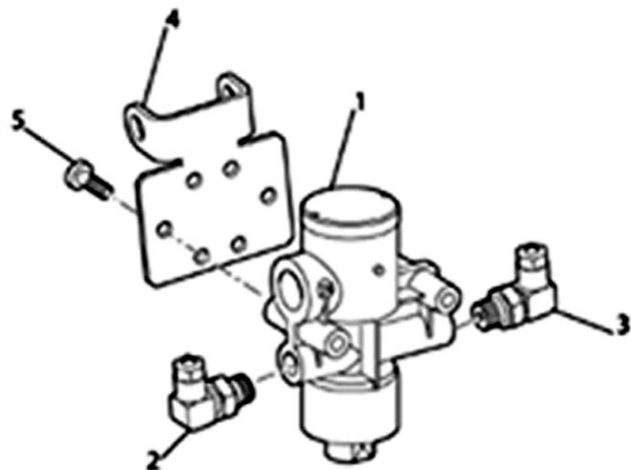

1. Filter regulator
2. Air fitting
3. Air fitting
4. Bracket
5. Screw

Air system

Selector valve removal and refitment

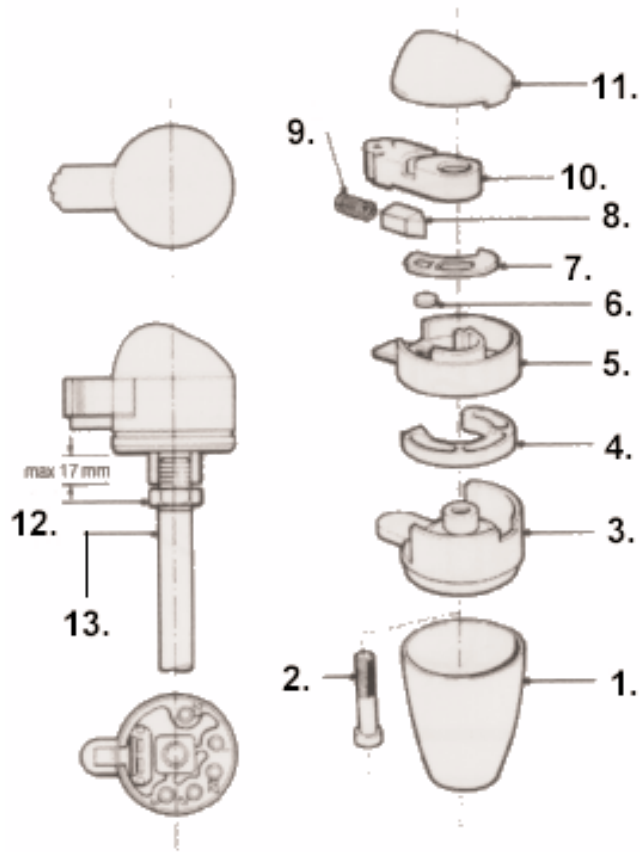

- | | |
|-----------------------|-----------------------|
| 1. Cowl | 8. Plunger |
| 2. Socket head screw | 9. Compression spring |
| 3. Base | 10. Lever |
| 4. Seal | 11. Cap |
| 5. Housing | 12. Lock nut |
| 6. Pressure pad | 13. Shift lever |
| 7. Anti-rattle spring | - Lubricant (sachet) |

Removal and disassembly

1. Remove cowl.
2. Disconnect all air lines.
3. Loosen lock nut and unscrew selector valve from shift lever.

4. To disassemble the valve remove socket head screw (2).

Note: Take care not to break tang from cap.

5. Thoroughly clean inside of selector valve.

Refitment

1. Renew seal ensuring that it is fitted correctly.
2. Smear sealing surface of base using lubricant supplied in Service Kit.

Caution: Do not use any other type of lubricant.

3. Reassemble valve and tighten socket headed screw to the correct torque.

4. Screw selector valve onto shift lever and secure with locknut.

Note: Only screw down max. 17 mm, otherwise the housing will be deformed and the valve will leak.

5. Connect all air lines and test for leaks.
6. Refit cowl.

Torque:

Socket head screw (No. 2) = 10 to 12 Nm.

Air connections = 2.7 to 3.4 Nm.

Trouble shooting hints

- Check that valve functions correctly.
- Check all air connections for leaks.
- Remove valve from gear lever and check socket head screw (No. 2) for tightness.
- If leaks persist renew the seal (No. 4).

Air system

Slave valves

The changeover from 'low' range to 'high' range and vice versa is controlled on single H shift transmissions by means of the selector valve which in turn activates the slave valve, or on double H transmissions by direct mechanical activation of the slave valve by a cam/detent on the remote control shift lever.

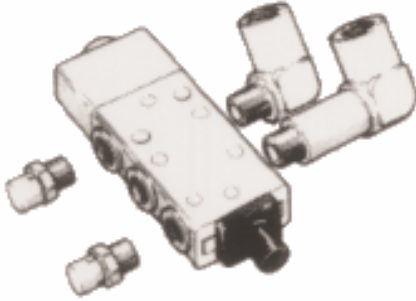

Slave valve - Single H (constant feed to range cylinder)



Slave valve - Single H shift (Air feed to range cylinder only present when transmission is in neutral) - Mecman valve.

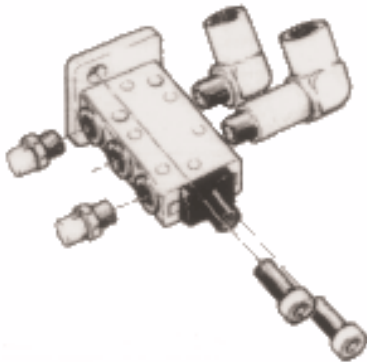

Slave valve - Double H shift

The slave valve supplies air to push the shift cylinder piston rearwards into the 'low' ratio position or forwards into the 'high' ratio position as required.

An interlock pin between the selector shaft and the shift cylinder piston shaft only allows the range shift to take place when the gear lever is in the neutral position. With single H shift transmissions this also allows for range changes to be pre-selected.

Additionally the single H system (Non Mecman) has an exhaust air control valve. This effectively provides a buffer of air on the reverse side of the piston preventing it from moving, until the gear change lever is moved to the neutral position, when this air is exhausted to atmosphere.

The Mecman single H air system incorporates a valve fitted to the LRC which is designed such that air passing through to the range change cylinder is only present when the transmission is in neutral.

The valves are sealed maintenance free units and must be renewed if faulty.

Slave valve renewal

Removal

1. Drain the vehicle air reservoirs.
2. Disconnect the air lines from the slave valve.
3. Remove the slave valve either from the mounting bracket two capscrews, or from the remote control housing two socket headed capscrews.
4. Unscrew and remove the breather valves and elbow/adaptors from the valve, noting the position and port numbers for reassembly to the new valve.

Refitting

1. Clean off sealant from breather valves and elbow/adaptors, and ensure airways are clean and unrestricted. Renew breather valves if their serviceability is in doubt.

Air system

Slave valves

- Using PTFE tape or suitable Loctite sealer, install the breather valves, plugs and elbow/adaptors into the valve. (As applicable)
- Single H shift slave valve - Assemble the valve to the mounting bracket, tighten the retaining capscrews to the correct torque.
- Double H shift slave valve or single H shift air control valve - Using a new gasket, if applicable, fit the valve to the remote control. Tighten all fastenings to the correct torque.
- Reconnect the air lines, recharge the vehicle air reservoirs and check for correct function and to ensure freedom from air leaks.

Remote control air control valves - Single H

Poppett valves



Mecman Valve



Exhaust Valve

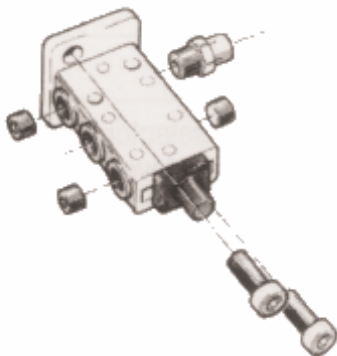

Air system

Range change shift cylinder

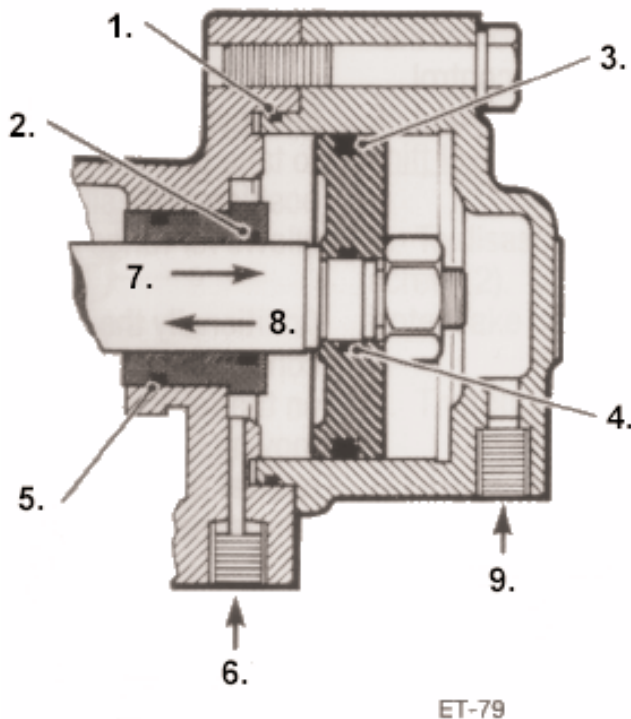

- | | |
|-----------|------------------------|
| 1. O-ring | 6. Low range air port |
| 2. O-ring | 7. Low range |
| 3. O-ring | 8. High range |
| 4. O-ring | 9. High range air port |
| 5. O-ring | |

Sectional view of range change shift cylinder

Operation

By switching the selector valve on the gear lever, or by moving the gear lever across the detent between 4th and 5th gears air is supplied by the slave valve to either the high range or low range air port.

Air pressure on the other side of the piston is exhausted to atmosphere through the slave valve. There is a constant air pressure acting against one side or other of the piston at all times on double H and single H transmissions other than on the Mecman system. On the Mecman system air is only supplied to the range change piston when the transmission is in neutral.

Trouble shooting

Range change not operating - check air pressure/supply to and from regulator valve and from slave valve to range shift cylinder - See circuit diagrams.

Air leaks from O-rings 1 to 5 in sectional view will result in following faults.

1. External air leak around cover.

Slow or no shift into low range.

2. Air leak into transmission.

Slow or no shift into low range.

3. Slow or no change into high or low range - also air leak out of slave valve breather valves.

4. Slow or no change into high or low range - also air leak out of slave valve breather valves.

5. Air leak into transmission.

Slow or no shift into low range.

Note: O-rings numbered 1, 3 and 4 may be renewed without dismantling transmission.

Air system

The pneumatics used on the Nine speed synchromesh transmission can be categorised as either single H or double H control.

The double H air system has remained largely unchanged over the years whereas the single H air system has undergone a number of design changes and modifications.

The following diagrams should be used to determine the type and design level of the air system used on the transmission being serviced. In all cases reference should be made to the air control valve fitted to the remote control (LRC) to determine the type of air system.

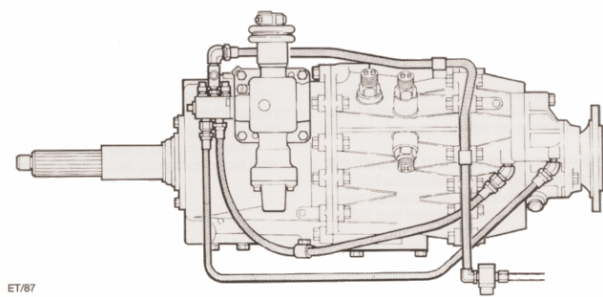

See page - 2/10

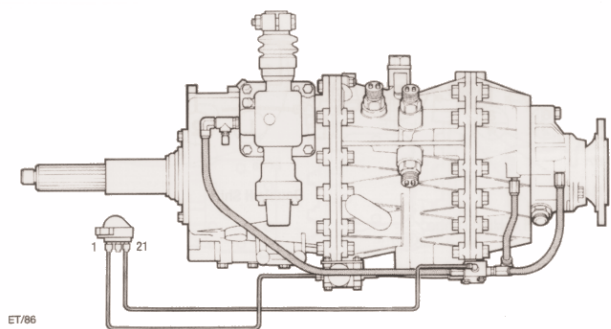

See page - 2/13

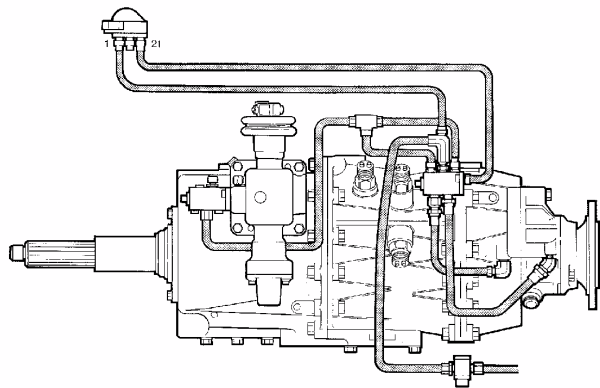

See page - 2/11

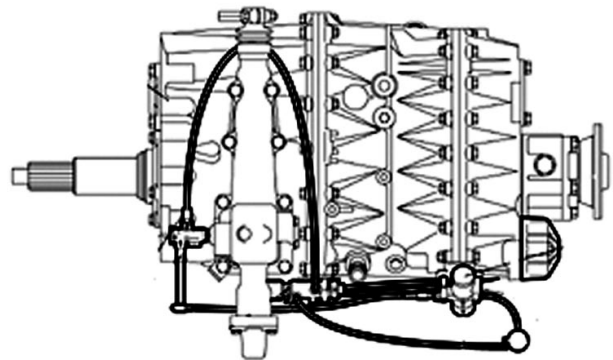

See page - 2/17

Once identified refer to the relevant pages to determine the mode of operation.

Air system

Range change shift air circuit diagrams - Double H

Air circuit diagram - Double H shift - Low range

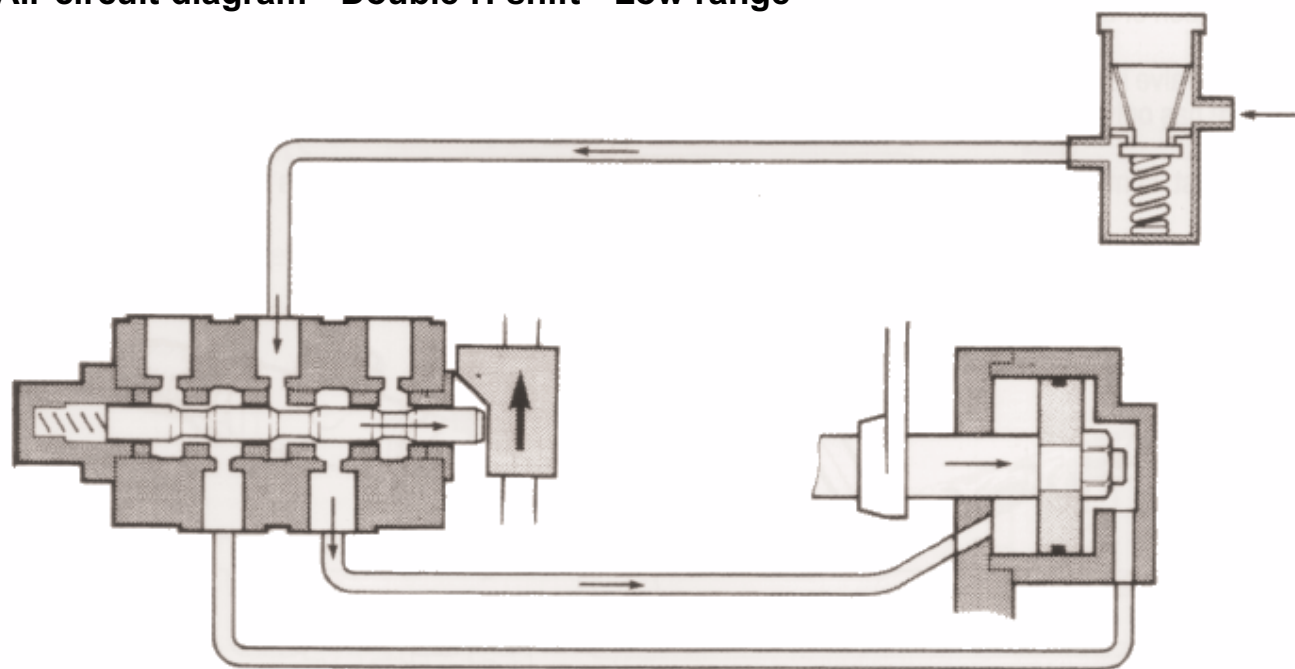

Air circuit diagram - Double H shift - High range

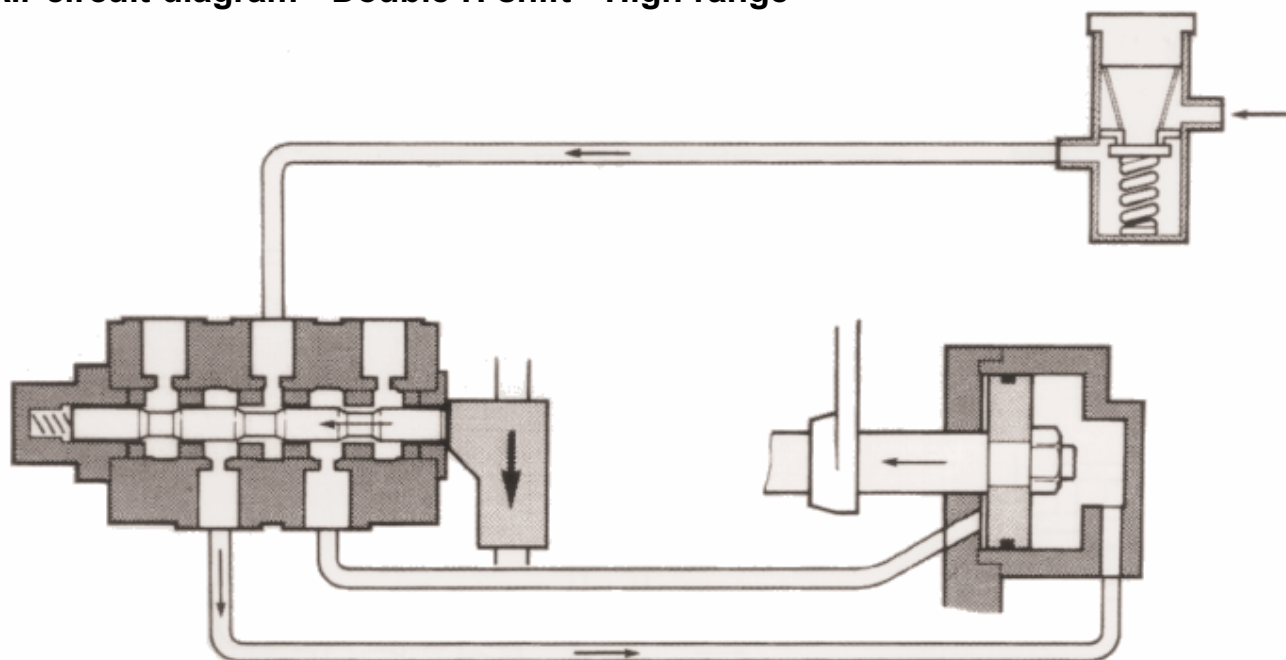

Air system

Range change shift air circuit diagrams - Single H

Air circuit diagram - Single H shift - Low range (4th gear) engaged

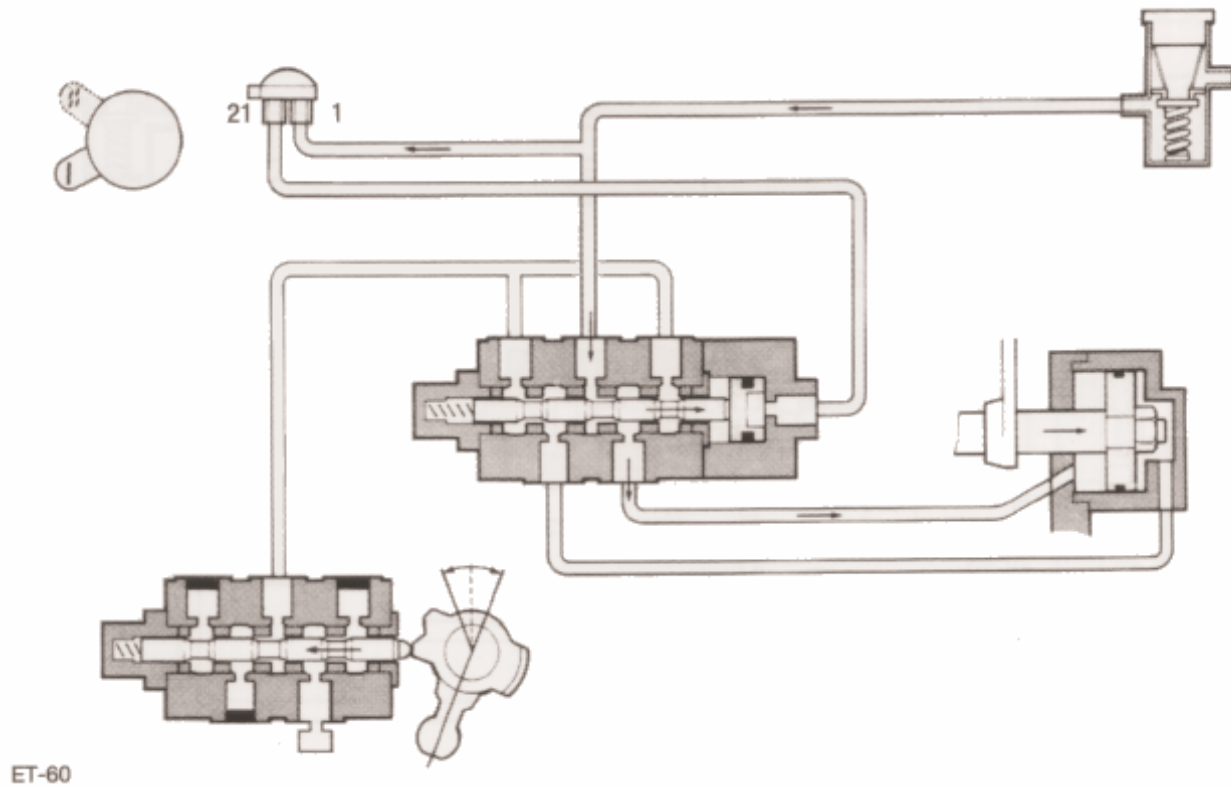

Air circuit diagram - Single H shift - High range preselected

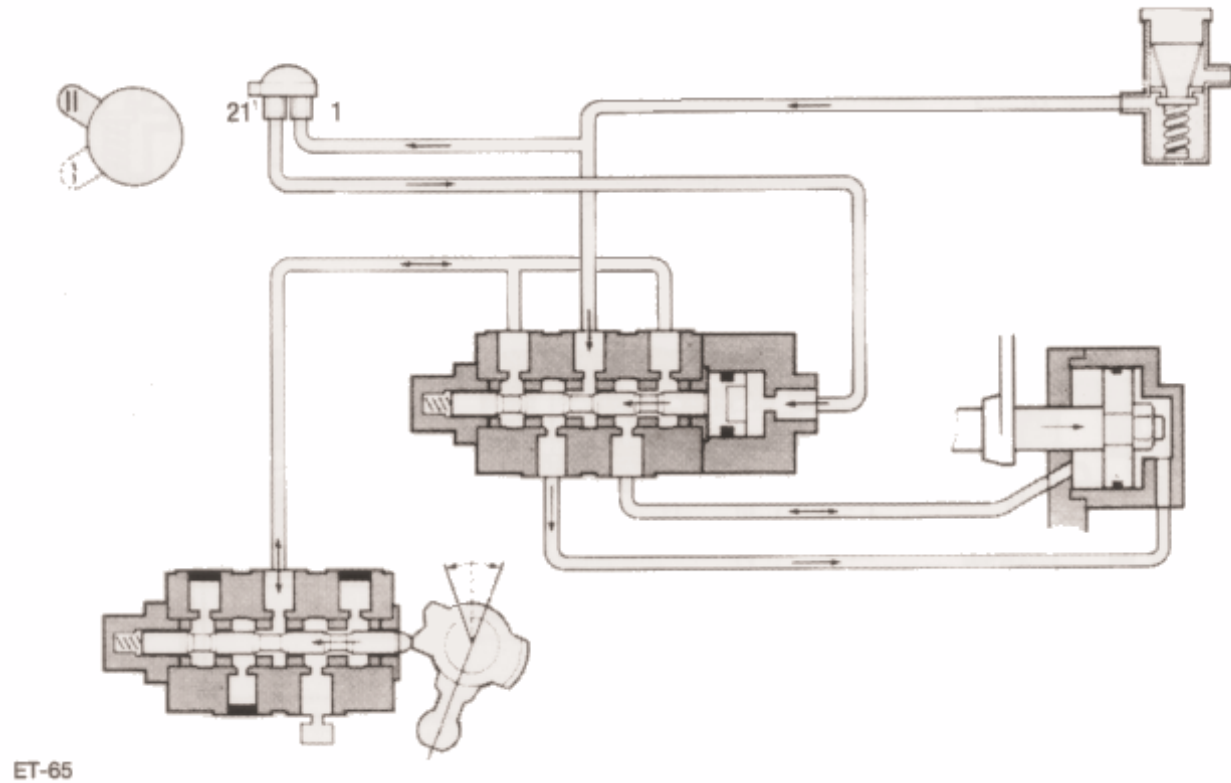

Air system

Air circuit diagram - Single H shift - Neutral engaged - Exhaust air pressure released - High range engaged

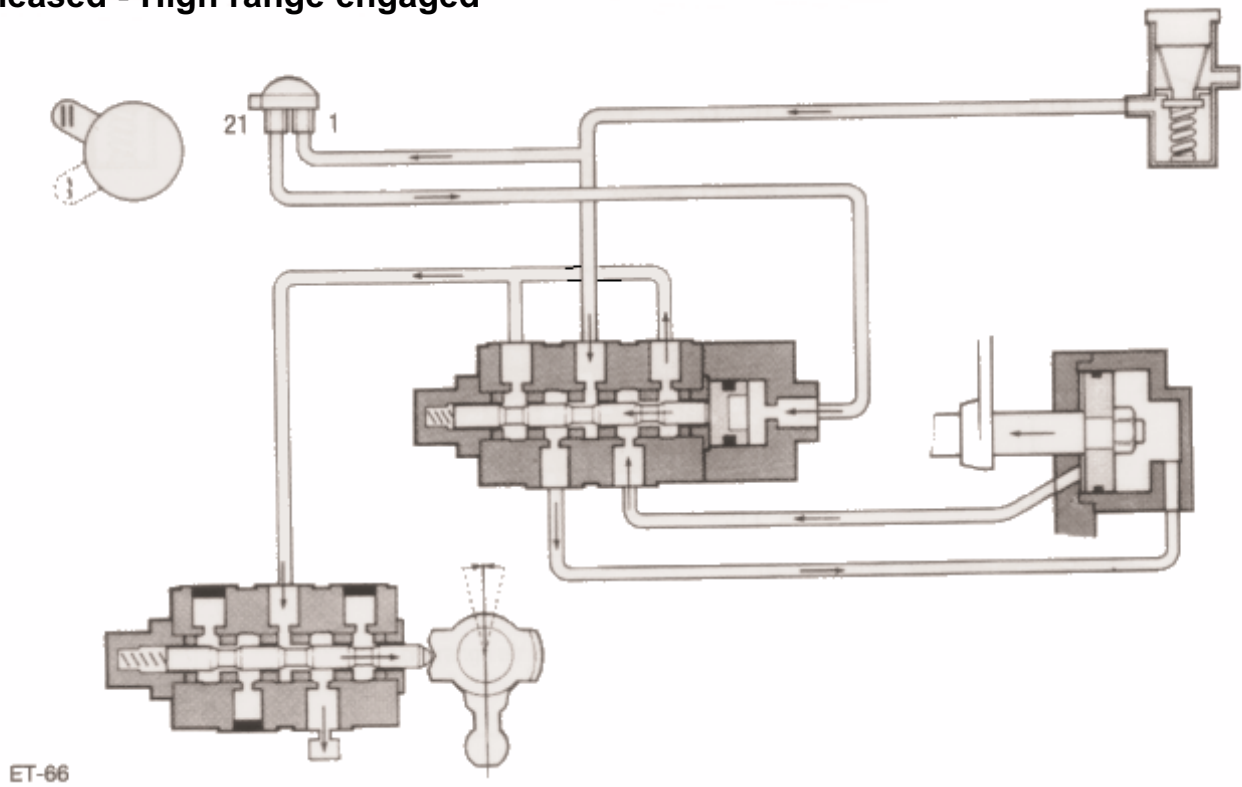

Air circuit diagram - Single H shift - High range (5th gear) engaged

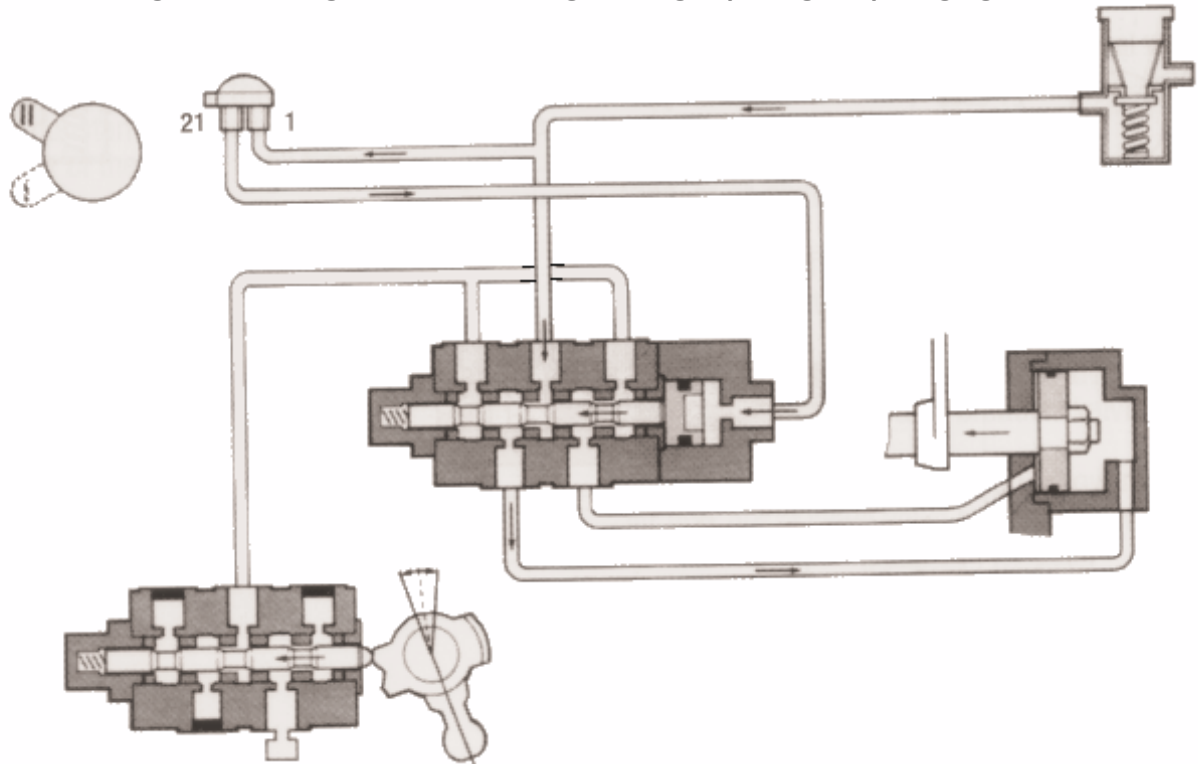

Air system

Single H

Some transmissions may be fitted with a revised air system as shown in the following pages.

The operation of the air system range change is unaltered, only the valves and pipework change.

The slave valve is replaced by an updated valve which connects the two exhaust lines internally and therefore has only a single port.

The exhaust control valve is a single poppet valve which functions in the same way as the former valve.

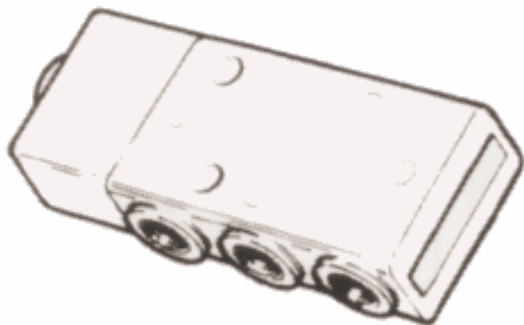

Slave valve

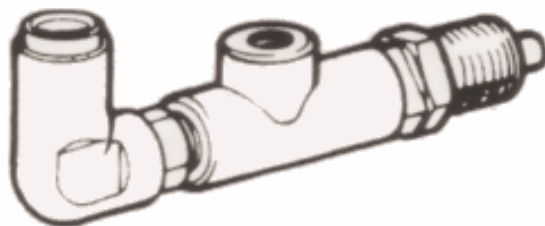

Exhaust control valve

Air system

Range change shift air circuit diagrams (continued)

Air circuit diagram - Single H shift - Low range (4th gear) engaged

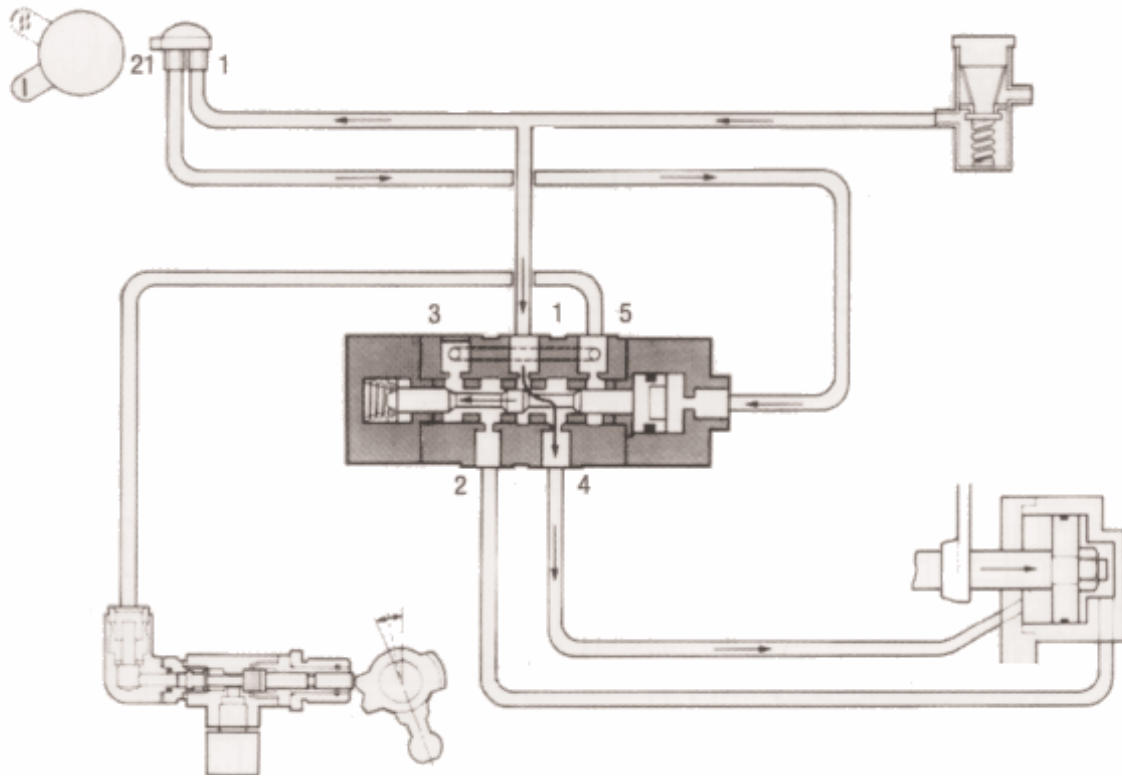

Air circuit diagram - Single H shift - High range preselected

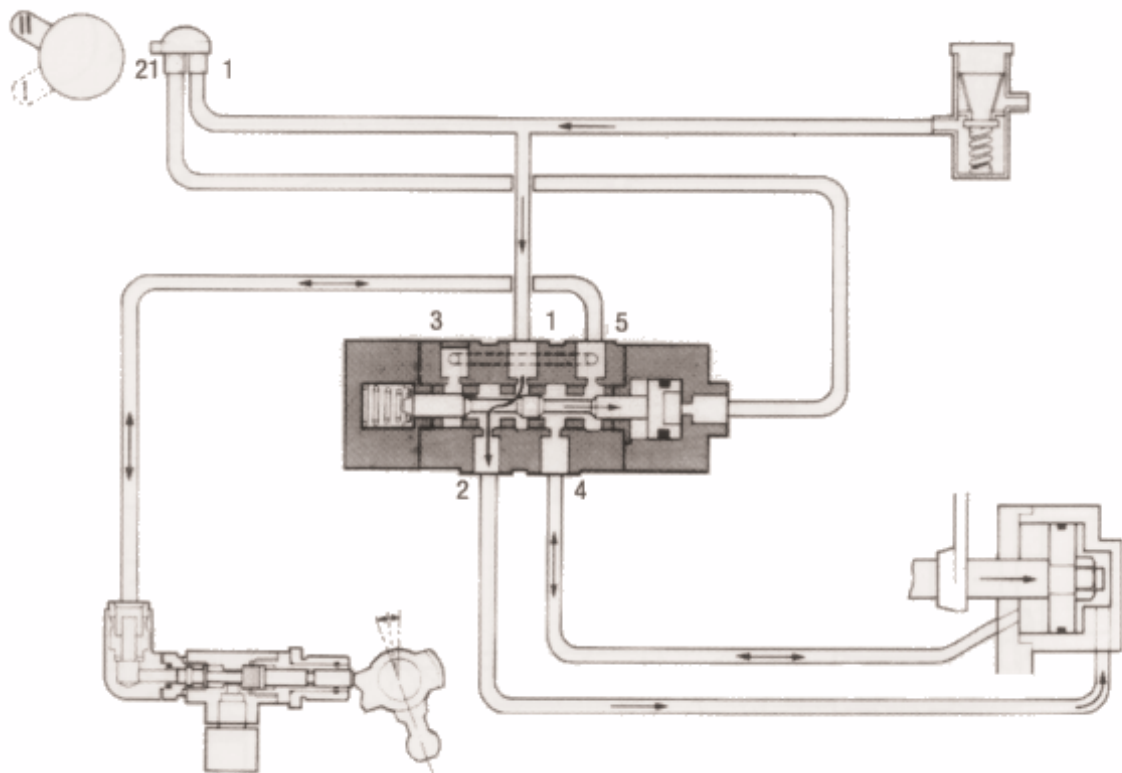

Air system

Range change shift air circuit diagrams - with range inhibitor

Air circuit diagram - Single H shift - Low range (4th gear) engaged

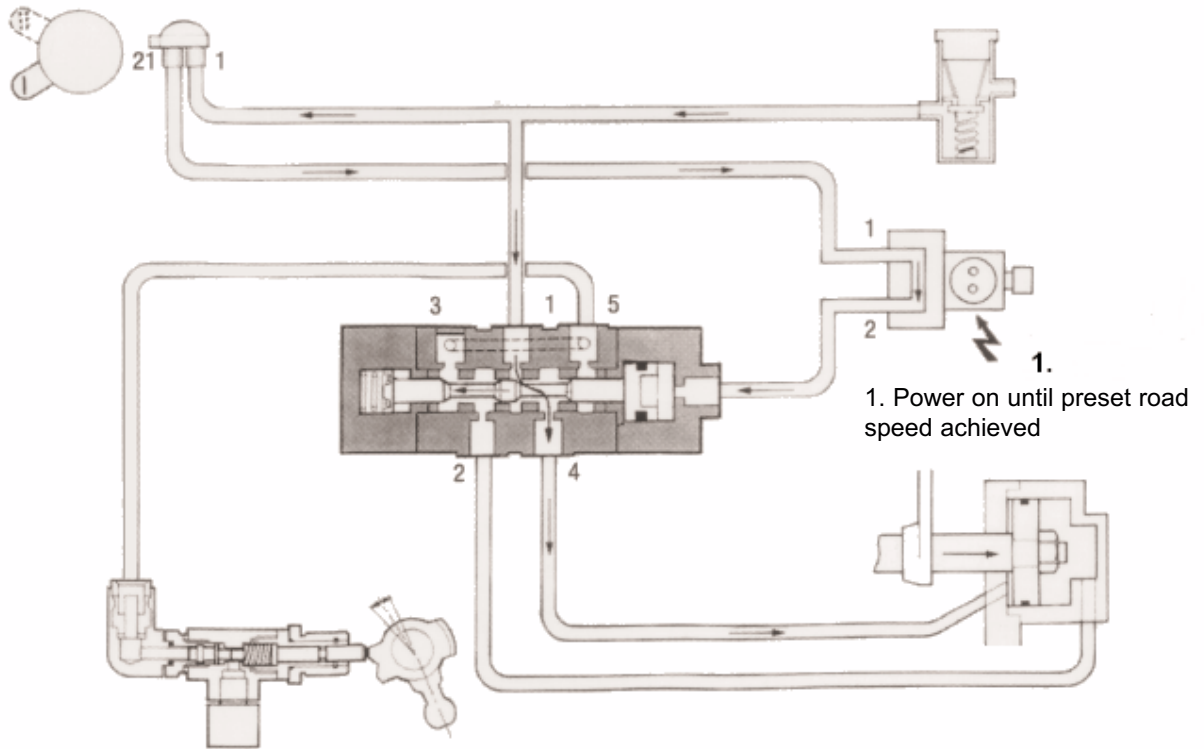

Air circuit diagram - Single H shift - High range (5th gear) engaged

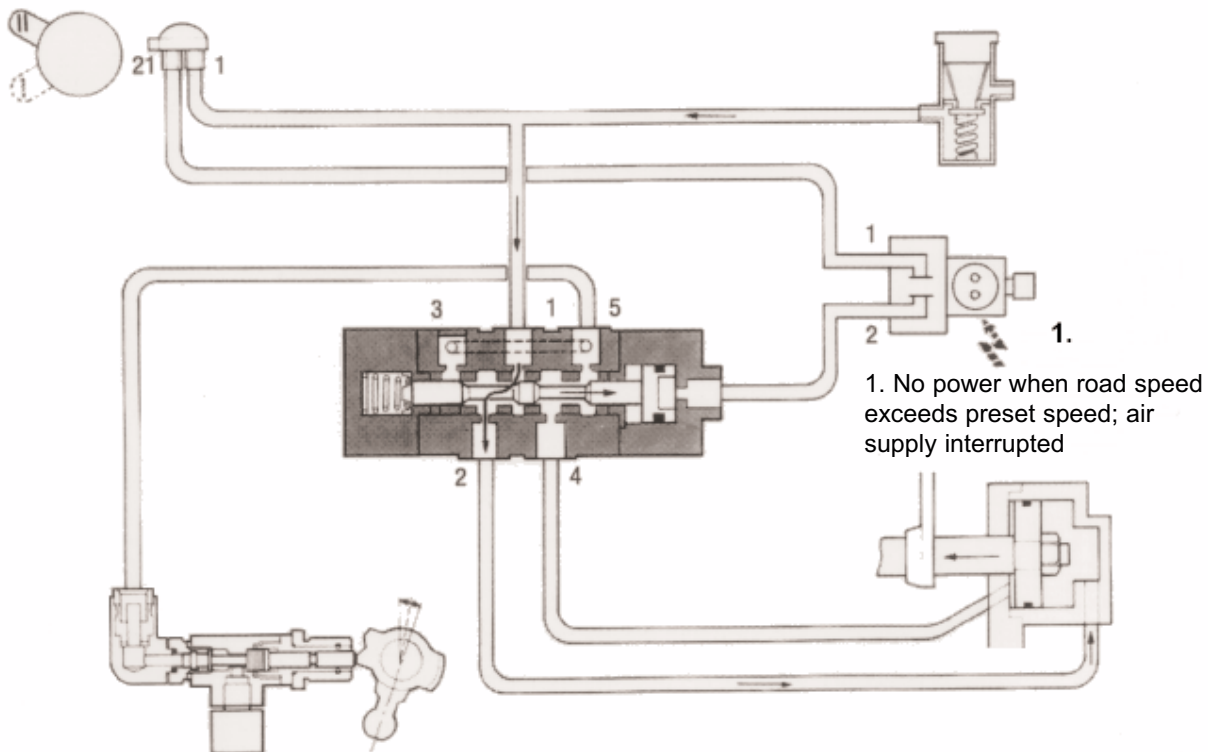

Air system

Single H

Some transmissions may be fitted with a revised air system as shown in the following pages. The arrangement shown is referred to as the 'Mecman' air system.

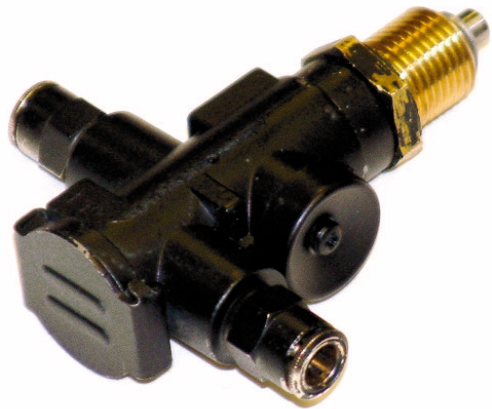
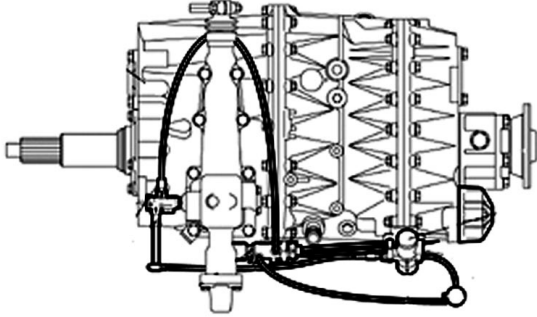

Air system

As part of the process of continuous improvement modifications have been made to the air system currently fitted to the nine speed synchromesh transmissions. The change to the current design sees the introduction of a 'neutral feed' range change slave valve (Mecman valve) and LRC poppet valve.

Important

These changes, which affect the way in which the air system works, can only be used on transmissions where Pyrolitic synchronisers have been fitted.

The new description of the system operation is as follows

Transmission in neutral – Low range engaged

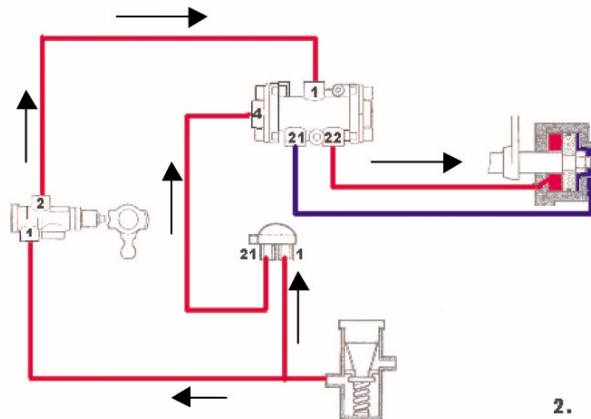

- The filter regulator supplies constant air (regulated to 5,5 bar) to both the hand control valve (port 1) and LRC poppet valve (port 1).
- When in neutral air is supplied from the LRC poppet valve (port 2) to the range change slave valve (port 1).
- When the hand control valve is in the low range position the signal feed pipe from the hand control valve (port 21) to the range change slave valve (port 4) is pressurised. This causes a spool, within the range change slave valve, to be lifted off its seat. Air is now fed from port 1 of the range change slave valve through to port 22 and then on to the low side of the range change cylinder causing the piston to move rearwards - low range is engaged.
- Any air that may have been present in the high side of the range change cylinder vents through the range change slave valve to atmosphere.

Transmission in gear – Low range engaged

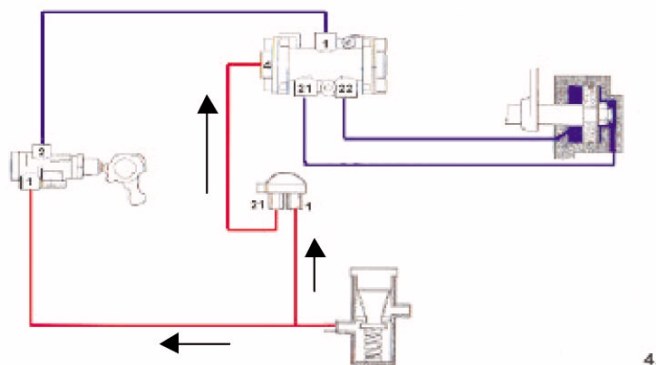

Air system

- When a gear is engaged the inner-striking lever of the LRC pushes against the plunger in the poppet valve. As the plunger is pushed inwards the air supply from the poppet valve (port 2) to the range change slave valve (port 1) and subsequently the range change cylinder is cut off venting any air within the range change cylinder to atmosphere.
- Whenever the gear lever passes through neutral the range change cylinder is momentarily pressurised.

Transmission in gear – High range preselected

- When the hand control valve is moved to the high range position the signal feed pipe from the hand control valve (port 21) to the range change slave valve (port 4) vents to atmosphere. This allows the spring within the range change slave valve to move the internal spool to its relaxed position.
- As the transmission is in gear the air supply from the poppet valve to the range change valve is not present therefore the transmission remains in low range.
- As the transmission is moved to neutral the poppet valve allows air to pass through to the range change slave valve and on to the range change cylinder to engage high range.

Transmission in Neutral – High range engaged

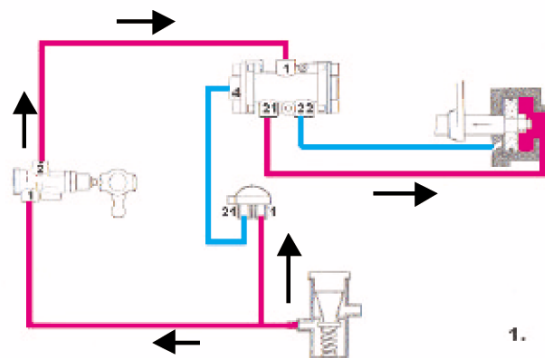

- The filter regulator supplies constant air (regulated to 5,5 bar) to the hand control valve (port 1) and poppet valve (port 1).
- Air is supplied from the poppet valve (port 2) to the range change slave valve (port 1)
- When the hand control valve is in the high range position the signal feed pipe from the hand control valve (port 21) to the range change slave valve (port 4) vents to atmosphere. The spring, within the range change slave valve, causes the internal spool to move to its relaxed position.
- Air is fed from the range change slave valve (port 21) to the high side of the range change cylinder causing the piston to move forwards - high range is engaged.
- Any air that may have been present within the low side of the range change cylinder vents back through the range change slave valve to atmosphere.

Air system

Transmission in gear – High range engaged

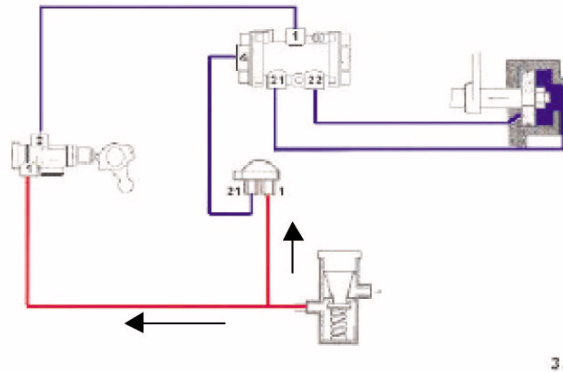

- When a gear is engaged the inner striking lever of the LRC pushes against the plunger in the poppet valve. As the plunger is pushed inwards the air supply from the poppet valve (port 2) to the range change slave valve (port 1) and subsequently the range change cylinder is cut off venting any air within the range change cylinder to atmosphere
- Whenever the gear lever passes through neutral the range change cylinder is momentarily.

Transmission in gear – Low range preselected

- When the hand control valve is in the low range position the signal feed pipe from the hand control valve (port 21) to the range change slave valve (port 4) is pressurised. This causes the spool, within the range change slave valve, to be lifted off its seat.
- As the transmission is in gear the air supply from the poppet valve to the range change valve is not present therefore the transmission remains in high range.
- As the transmission is moved to neutral the poppet valve allows air to pass through the range change slave valve and on to the range change cylinder to engage low range.

Air system

Range inhibition

For low range to be engaged the signal feed from the hand control valve (port 1) to the range change slave valve (port 4) must be present. If the signal feed is not present then the high range is engaged.

Where required the selection of low range can be inhibited above a pre-determined road speed by use of a range change slave valve that incorporates a normally closed electrical solenoid. This solenoid is designed to interrupt the signal feed from the hand control valve to the range change valve above a pre determined road speed.

Range change slave valve - with inhibitor solenoid

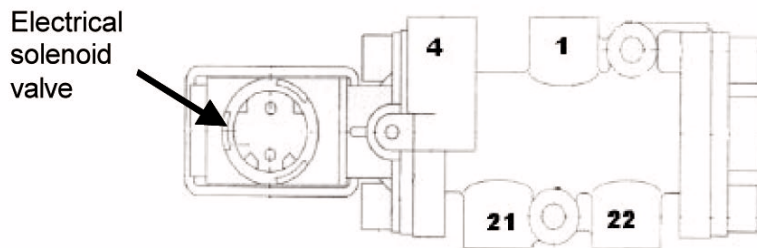

When the vehicle is below the pre determined road speed a 24-volt power supply energises the electrical solenoid.

As the electrical solenoid valve is energised the signal feed from the hand control valve to the range change slave valve is uninterrupted – low range or high range gears are available

Once the vehicle is travelling above the pre determined road speed the 24-volt power supply to the electrical solenoid is removed. The electrical solenoid valve is no longer energised therefore the signal feed from the hand control valve to the range change slave valve is cut off – only high range is available.

Note: - When the ignition is switched off the transmission will default to high range.

Section 3 Shifting Controls

Shifting controls

Remote control, single H - Exploded view

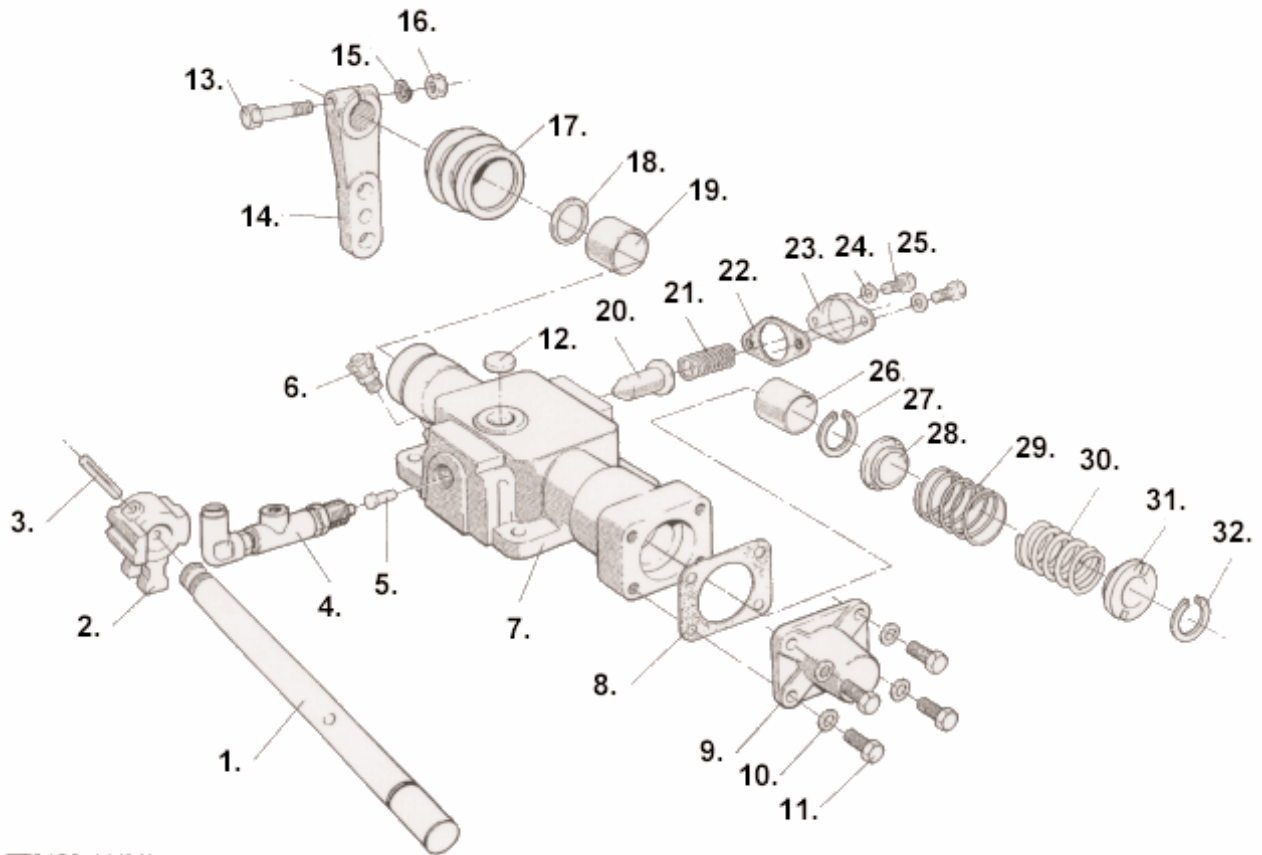

ET6109-11/2/1

- | | |
|-------------------------|------------------------|
| 1. Cross shaft | 19. Bush |
| 2. Inner striking lever | 20. Detent plunger |
| 3. Parallel grooved pin | 21. Compression spring |
| 4. Poppet valve | 22. Gasket |
| 5. Actuator pin | 23. Detent cover |
| 6. Breather | 24. Spring washer M8 |
| 7. Housing | 25. Screw M8 x 14 |
| 8. End cover | 26. Bush |
| 9. End cover | 27. Circlip |
| 10. Spring washer M8 | 28. Spring retainer |
| 11. Screw M8 x 30 | 29. Compression spring |
| 12. Expansion plug | 30. Booster spring |
| 13. Bolt M10 x 50 | 31. Spring retainer |
| 14. Outer lever | 32. Circlip |
| 15. Spring washer M10 | |
| 16. Nut M10 x 1.0 | |
| 17. Boot | |
| 18. Oil seal | |

Shifting controls Disassembly

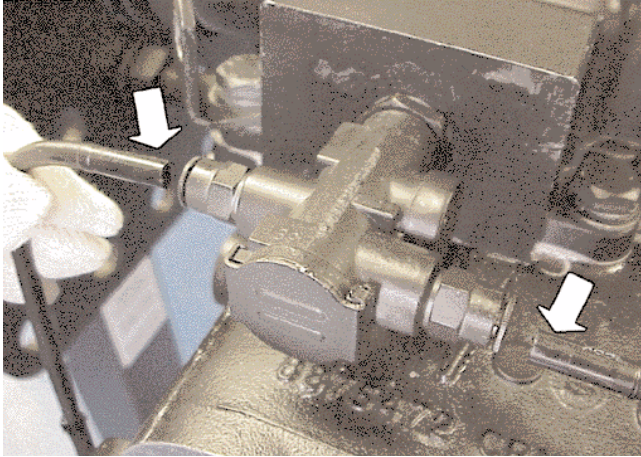

1. Disconnect the vehicle linkage. Note the position of the drop lever and remove the nut, washer, bolt and drop lever. Note the position and then disconnect the air lines from the LRC.



4. Remove the rubber boot

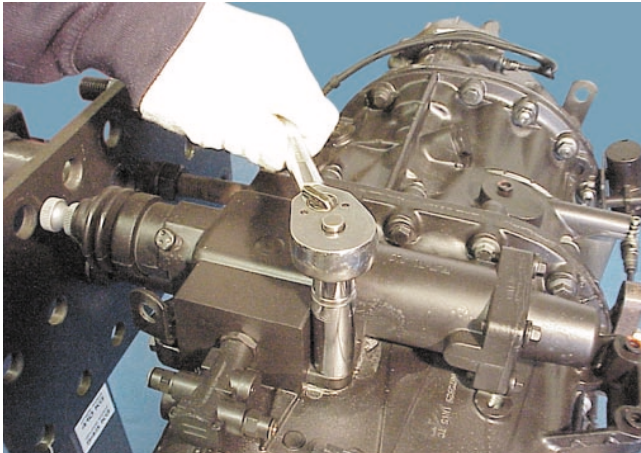

2. Remove remote control assembly from the transmission.

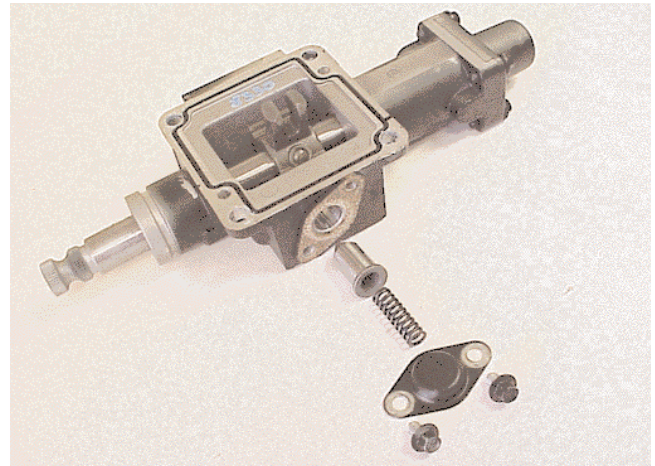

5. Reverse detent - Remove the screws, washers, cover plate, spring, plunger and gasket.

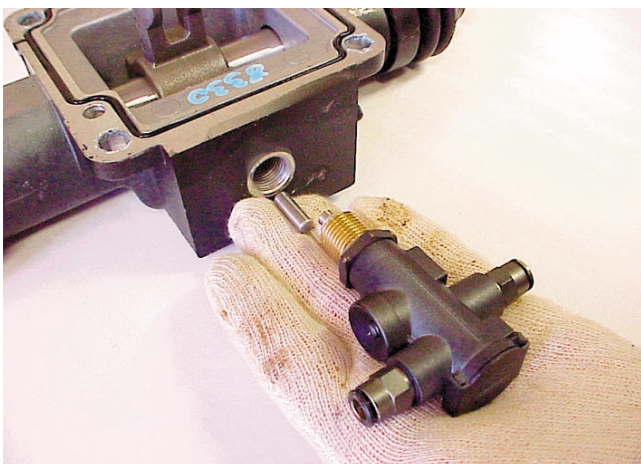

3. Remove the air control valve and actuating pin.

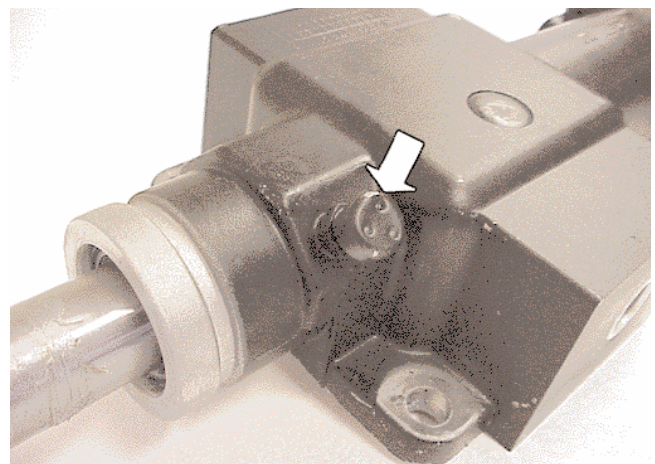

6. The breather may be removed if necessary.

Shifting controls

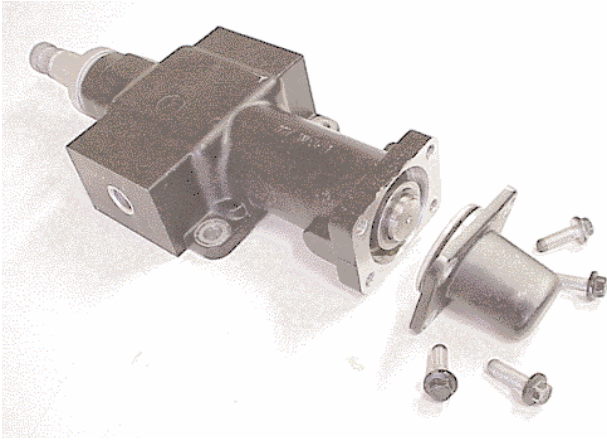

7. Remove the screws, washers, cover and, where fitted, gasket. Note; Elimination of the gasket has been achieved by incorporating an O ring into the end cover.

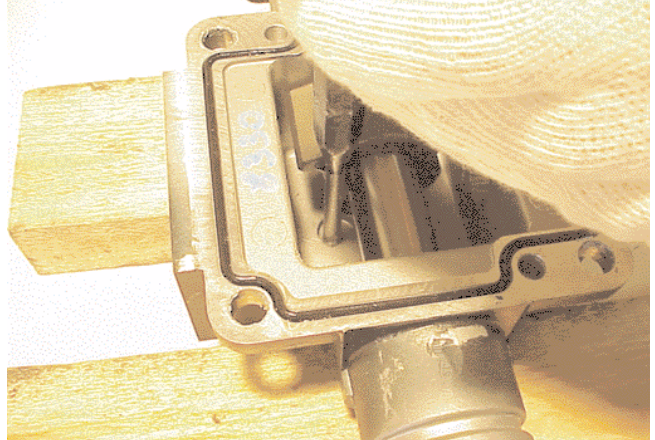

10. Invert the housing, slide the remote control shaft and inner lever toward the left-hand end of the housing and carefully drift out the expansion plug.

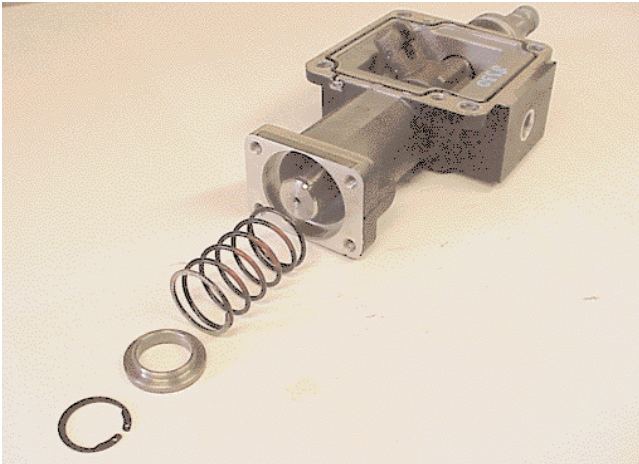

8. Remove the circlip and spring retainer. Withdraw the springs.

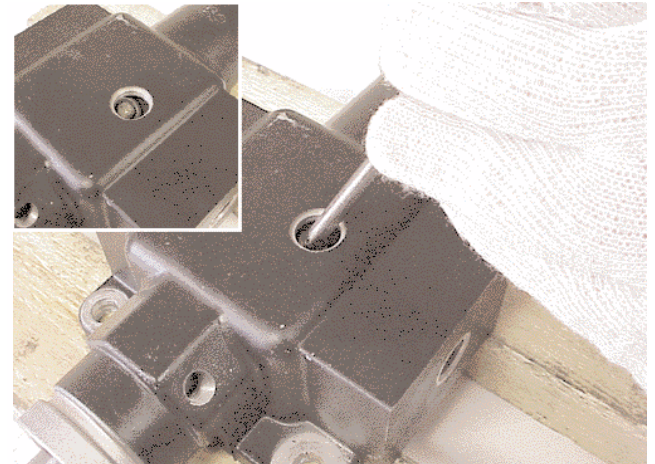

11. Invert the housing. Align the grooved pin in the inner lever with the expansion plug hole and drift out the pin.

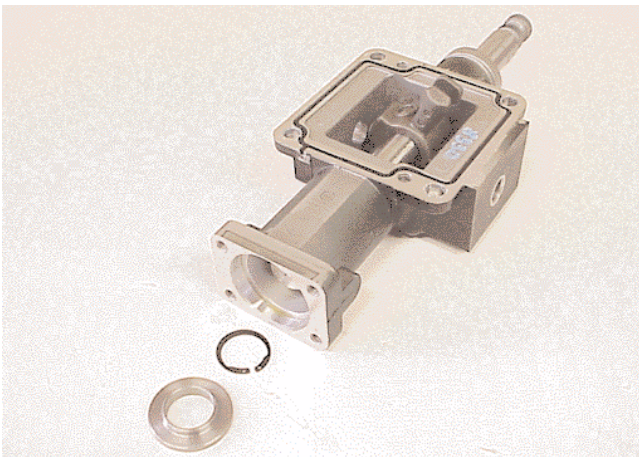

9. Remove the inner spring retainer and circlip.

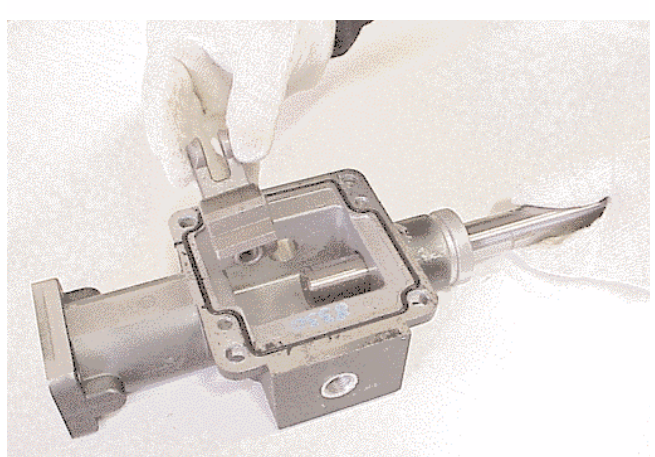

12. Remove the shaft and inner lever.

Shifting controls

Reassembly

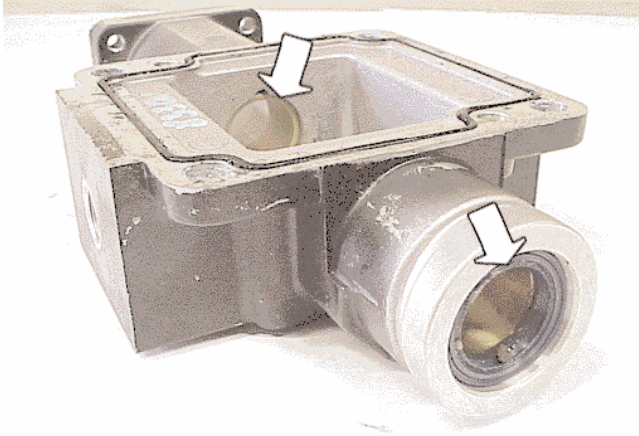

1. If necessary renew the bearing bushes in the housing. Remove the old bushes using tool MS 284-1 and install the new bushes using tool E 109-5.

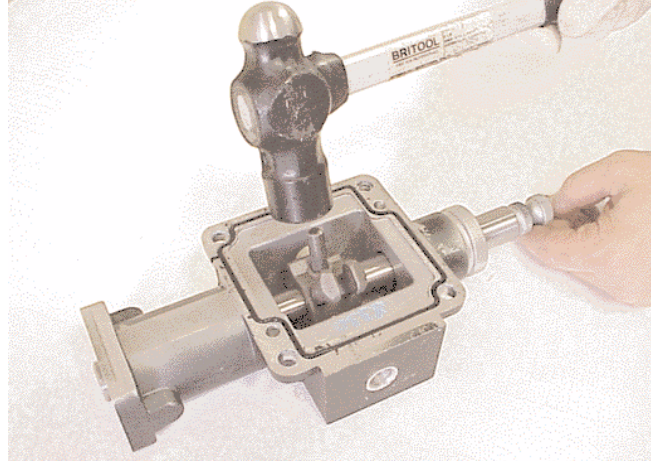

4. Align the inner lever on the shaft and install a new grooved pin, ensuring identification mark is in correct position.

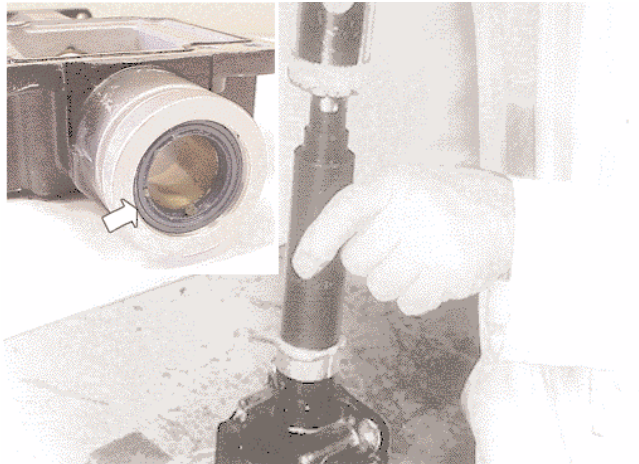

2. Renew the oil seal. Install the new seal using tool E 109-5.

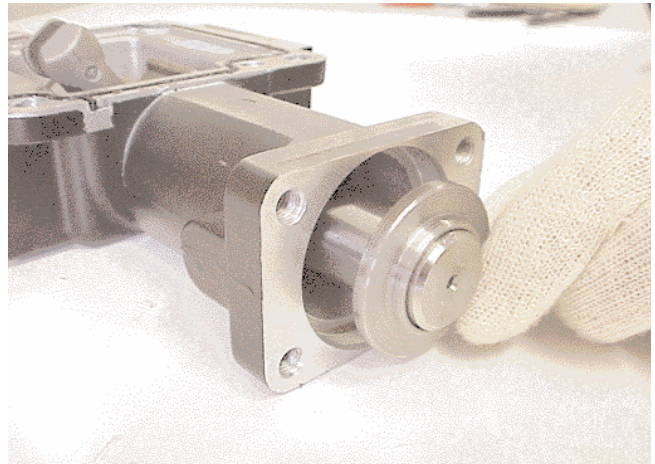

5. Fit the inner circlip and spring retainer onto the selector shaft.

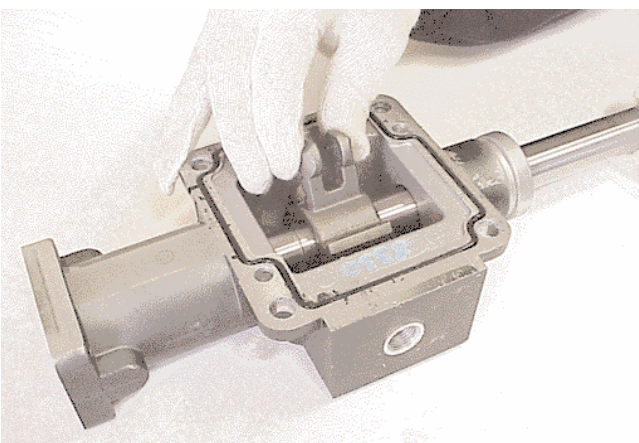

3. Locate the inner lever into the housing, long grooved side and retaining pin hole toward the rear. Install the shaft through the housing and the lever from the oil seal end of the housing.

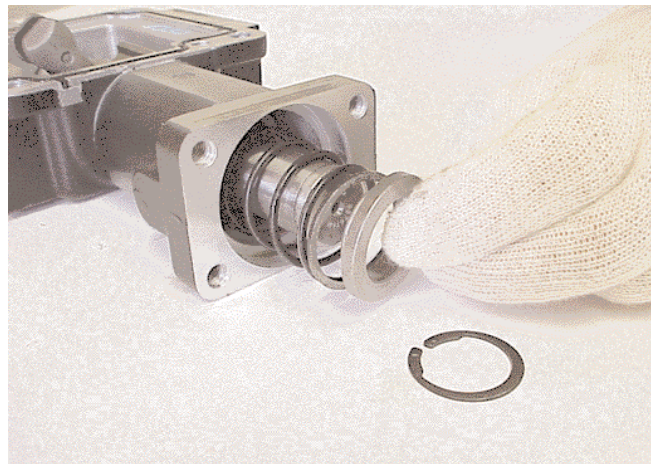

6. Locate the springs and outer retainer on the shaft. Fit outer circlip onto the shaft.

Shifting controls

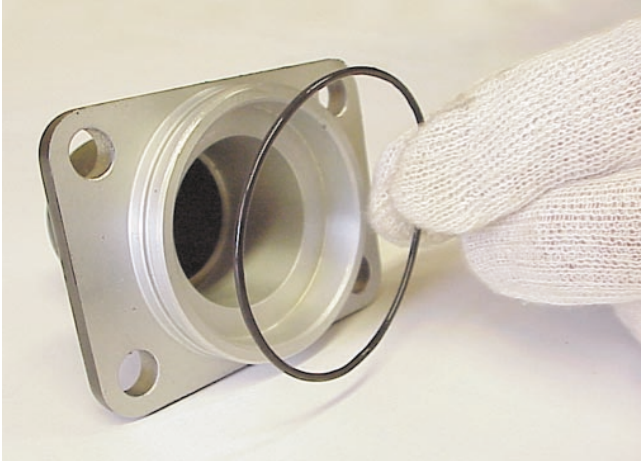

7. Where an 'O' ring is fitted to the end cover replace if necessary.

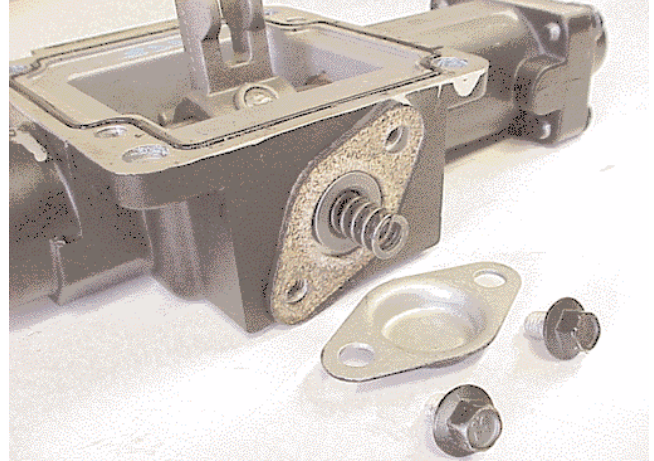

10. Support the housing assembly in the vice and install the reverse detent plunger and spring. Install the cover using a new gasket and tighten the retaining capscrews to the correct torque.

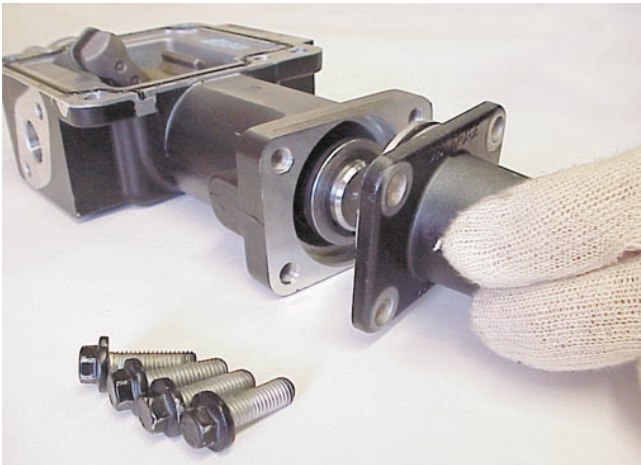

8. If an 'O' ring is not fitted to the end cover then a gasket is required. Fit the end cover, washers and screws.

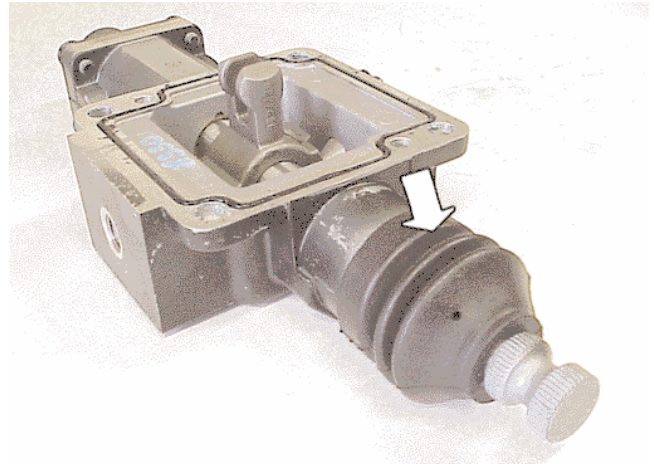

11. Fit rubber boot.

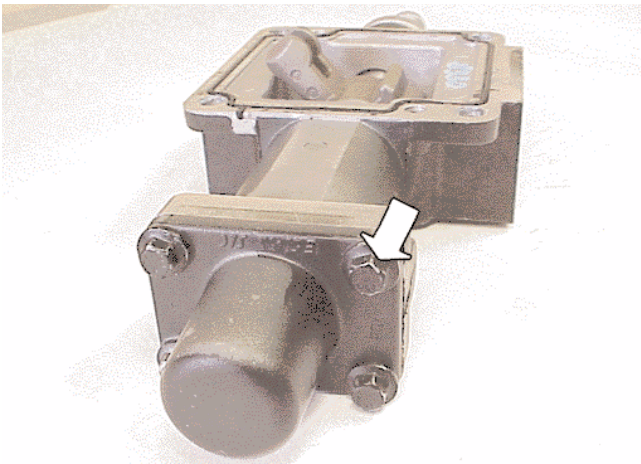

9. Apply sealant to the capscrews and tighten to correct torque.

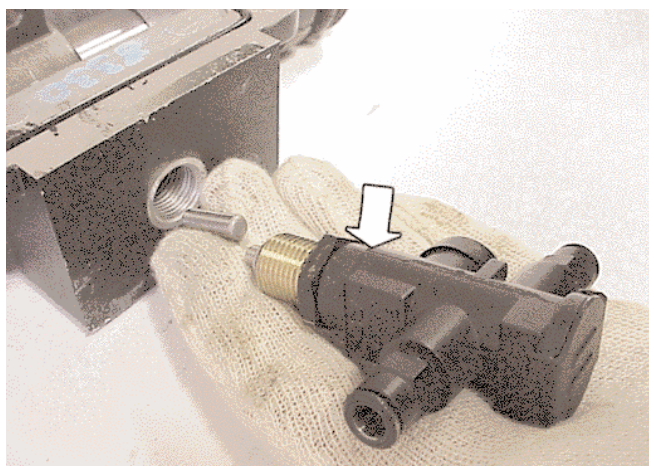

12. Fit the air control valve and actuating pin.

Shifting controls

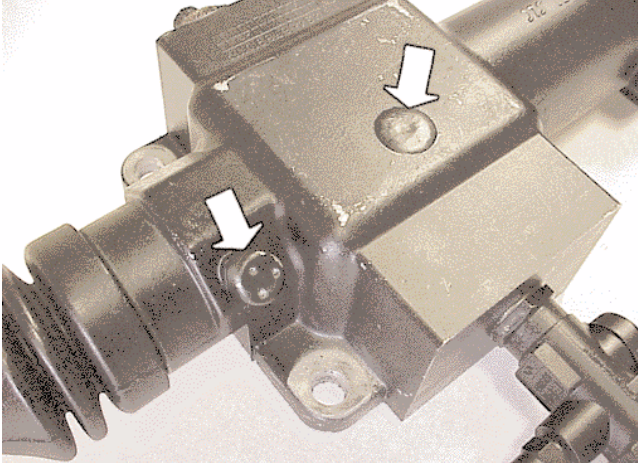

13. Fit the breather. Apply a coating of sealant to the expansion plug and then install.

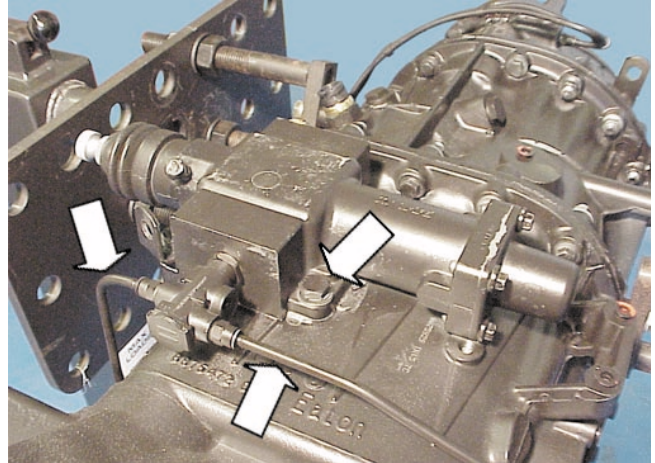

15. Fit the LRC to the transmission ensuring that the inner lever of the LRC locates the selector shaft shift block correctly. Fit the air pipes. Note; On the Mecman valve the feed pipe from the filter regulator valve must be fitted into port number one. Refit the drop lever and gear linkage.

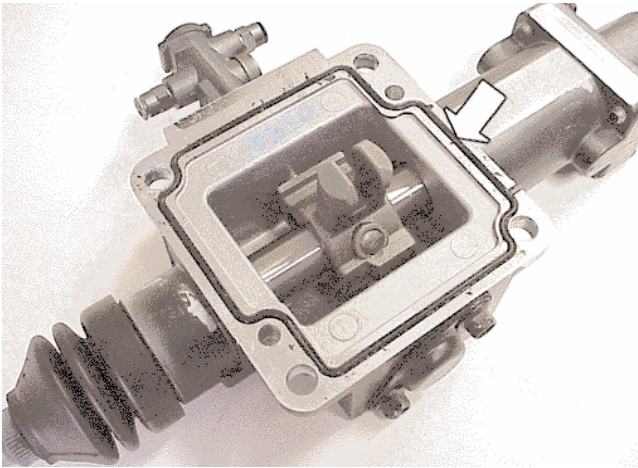

14. If an 'O' ring is fitted to the base of the LRC then replace if necessary. If an 'O' ring is not fitted then apply Loctite 5900 to the joint face.

Shifting controls

Remote control, double H - Exploded view

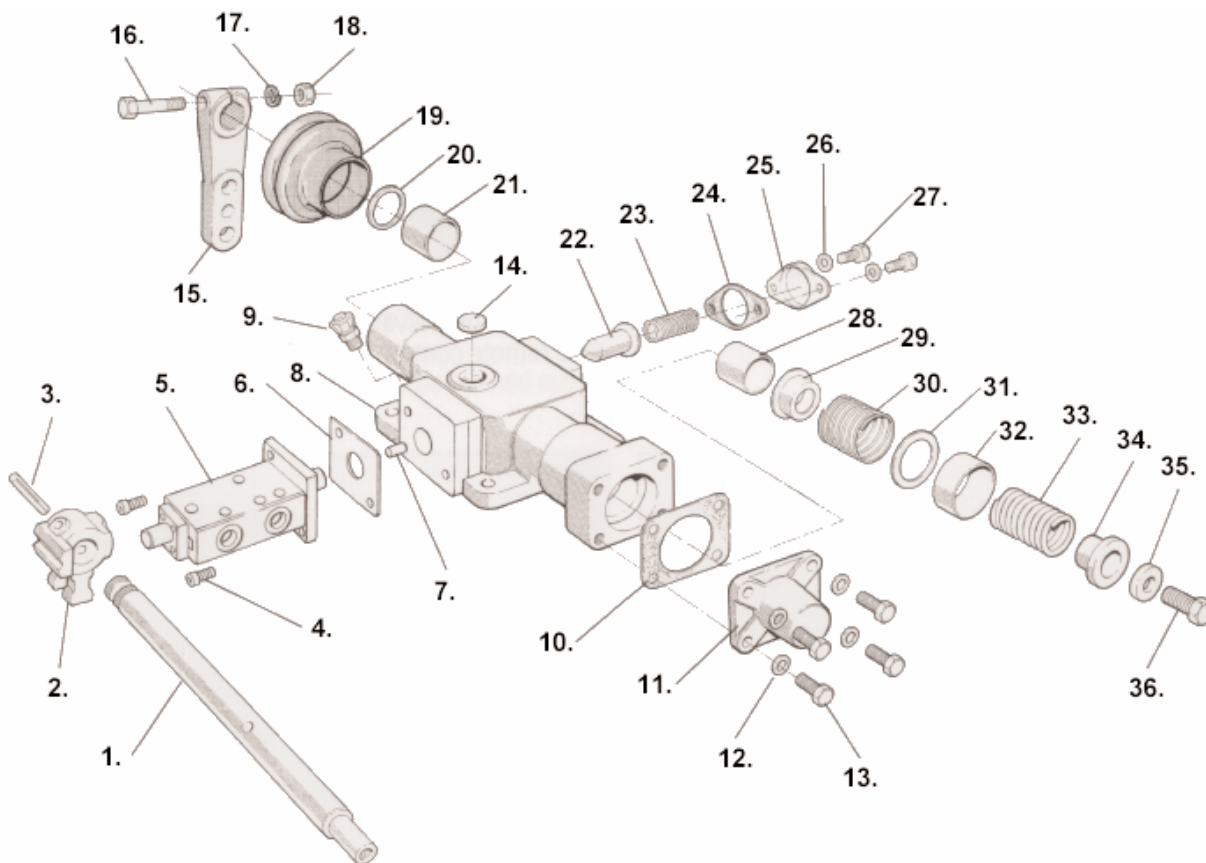

1. Cross shaft
2. Inner lever
3. Grooved pin
4. Screw
5. Valve
6. Gasket
7. Pin
8. Housing
9. Breather
10. Gasket
11. End cover
12. Spring washer
13. Screw
14. Plug
15. Outer lever
16. Bolt
17. Washer
18. Nut

19. Boot
20. Oil seal
21. Bush
22. Plunger - reverse detent
23. Spring - reverse detent
24. Gasket
25. Detent cover
26. Spring washer
27. Screw
28. Bush
29. Spring retaining cup
30. Spring (LH only)
31. Stop washer
32. Spacer
33. Spring
34. Bush
35. Washer
36. Screw

Shifting controls

Disassembly

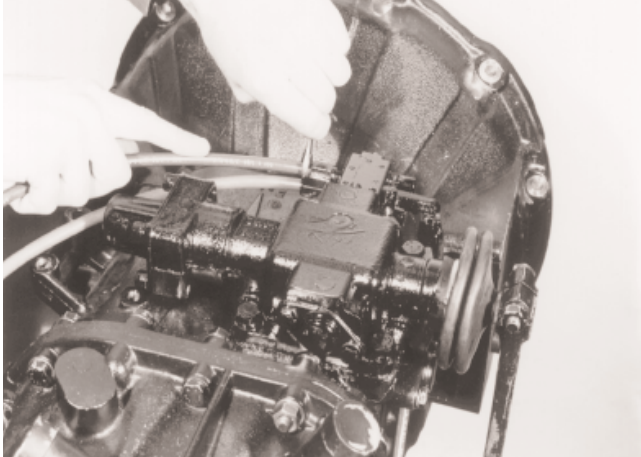

1. Use a 10 mm spanner to push the collar into the air fitting. Pull the pipe out of the fitting.

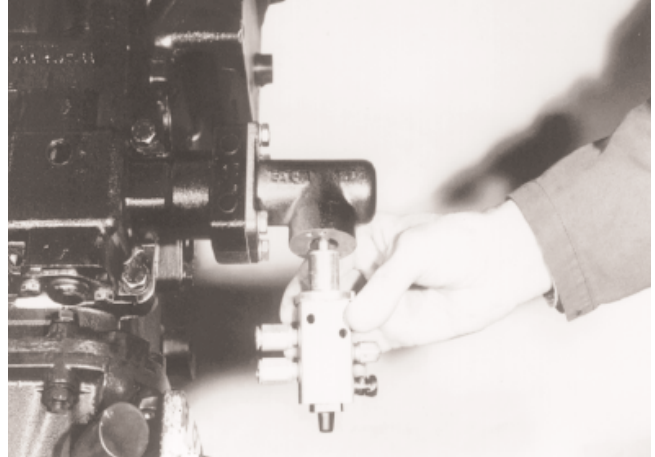

4. The slave valve may be fitted in the end cover of the remote control

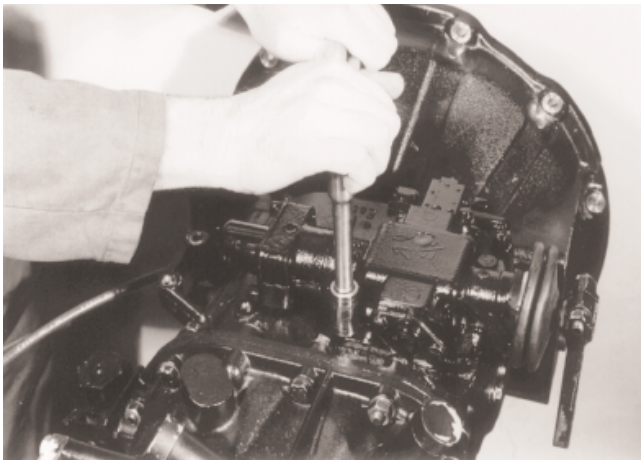

2. Remove the remote control assembly from the transmission.

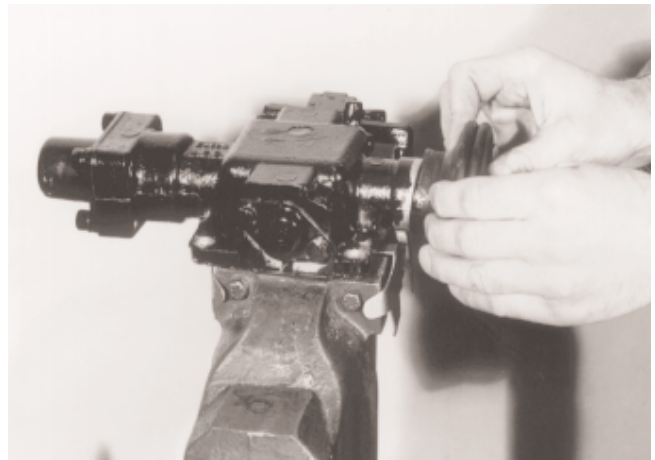

5. Remove the shift lever and boot. Note position of drop lever on cross shaft.

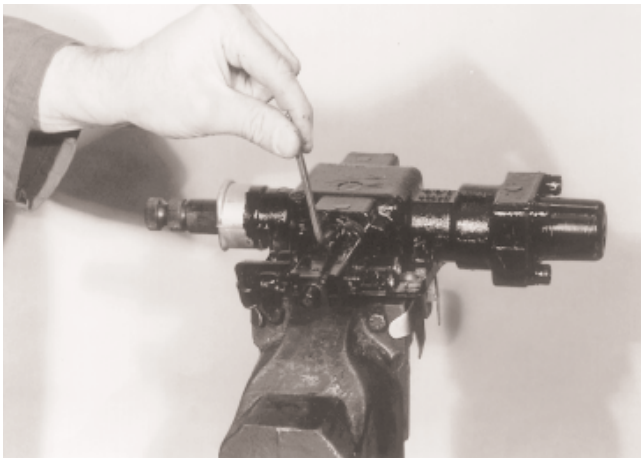

3. Support the remote control assembly in a soft jawed vice as shown and remove the two socket headed cap screws retaining the slave valve. Remove the slave valve and gasket.



6. Remove the reverse detent plunger cover and lift out the spring and plunger.

Shifting controls

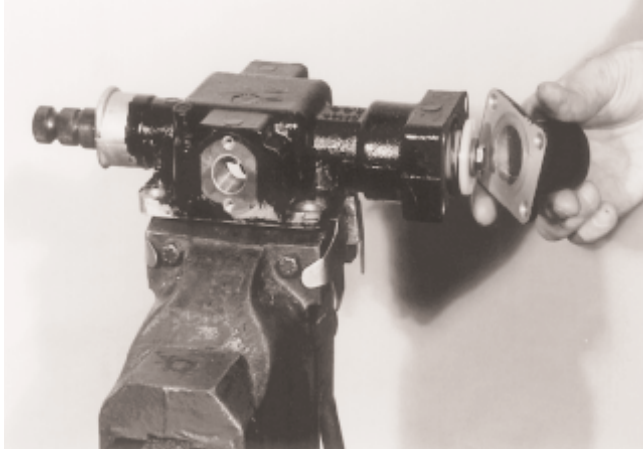

7. Remove the breather. Remove the four socket headed capscrews and the end cover.
Caution: The spacer or sleeve may be pushed out by the spring.

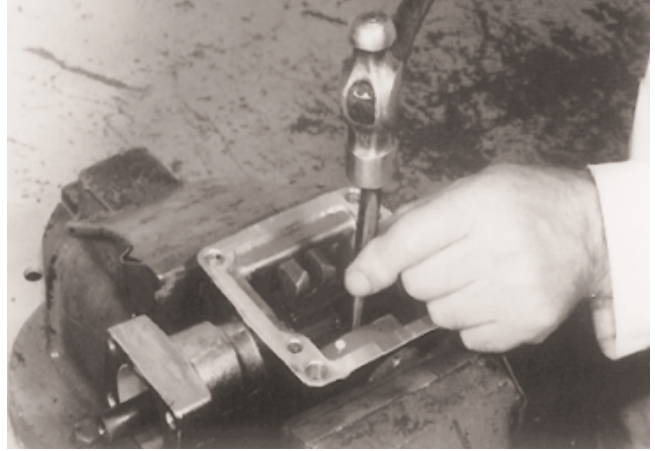

10. Invert the housing, slide the remote control shaft and inner lever toward the left-hand end of the housing and carefully drift out the expansion plug.

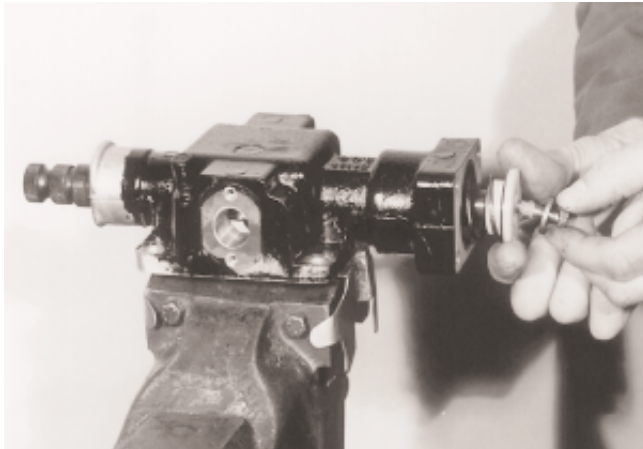

8. Remove the cap screw from the end of the shaft and remove the retaining bush, spring and the spacer.
Note: A circlip is fitted on models with the slave valve fitted in the end cover.

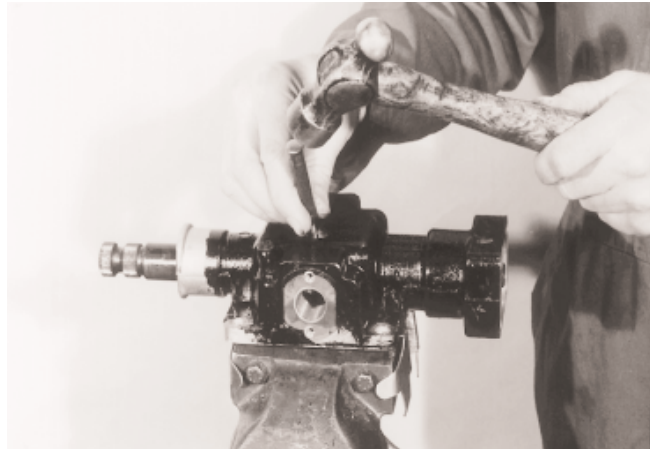

11. Invert the housing. Align the grooved pin in the inner lever with the expansion plug hole and drift out the pin. Remove the shaft and inner lever.



9. Remove the sleeve, spring cap and stop washer.

Shifting controls

Reassembly

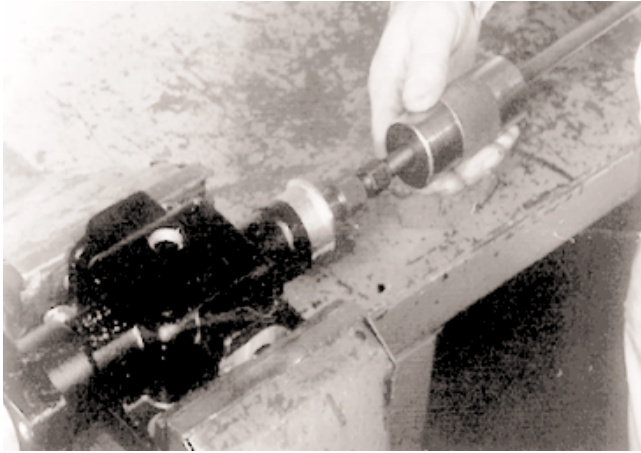

1. If necessary renew the bearing bushes in the housing. Remove the old bushes using tool MS 284-1 and install the new bushes using tool E 109-5.

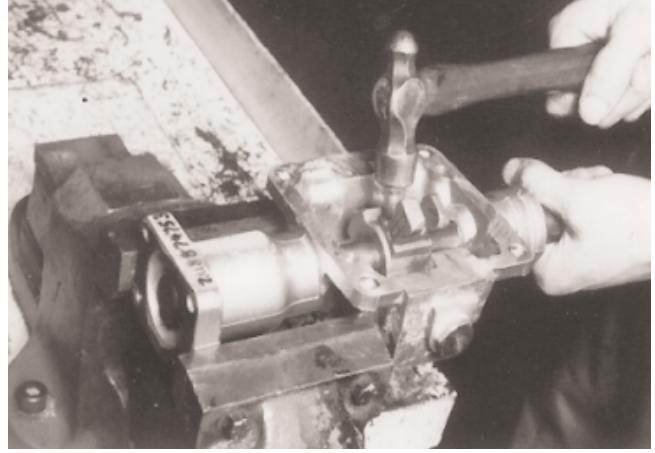

4. Align the inner lever on the shaft and install a new grooved pin, ensuring identification mark is in correct position.



2. Renew the oil seal. Install the new seal using installer tool E 109-5.

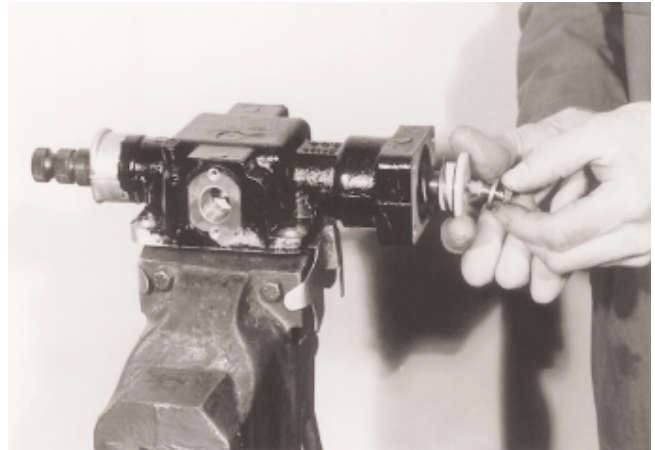

5. Install the spring retaining cup on the shaft and the springs and stop washer in the housing.
Note: Install the spring retaining bush on to the end of the shaft.

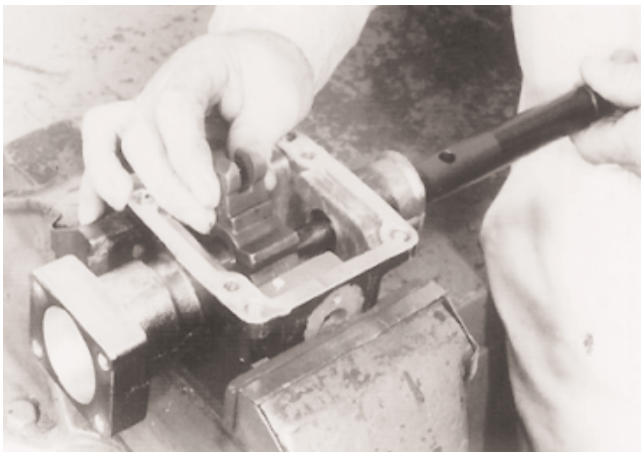

3. Locate the inner lever into the housing, long grooved side and retaining pin hole toward the rear, and install the shaft through the housing and the lever from the oil seal end of the housing.



6. Fit the spacer (left hand variants only), apply sealant (Loctite 242) to the retaining cap screw (or fit a new patch-lock screw) and tighten to the correct torque, compressing the spring(s).

Shifting controls



7. Install the stop ring, and locate the end cover with a new gasket to the housing, compressing the spring(s) into the housing.

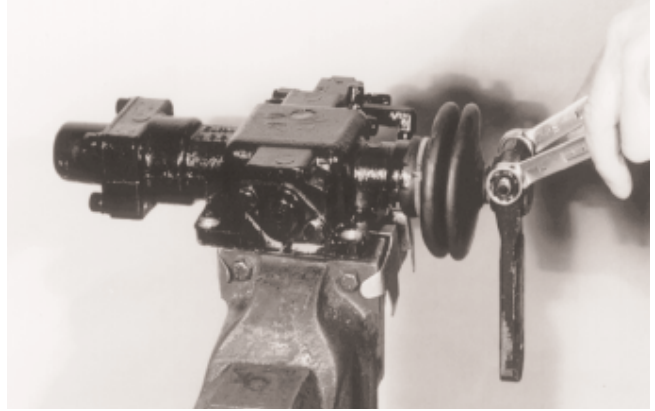

10. Align both levers and install the boot and outer lever, ball joint tapers facing outwards, on to the shaft. Fit the bolt, nut and washers and tighten to the correct torque. Apply a sealant and install a new expansion plug.

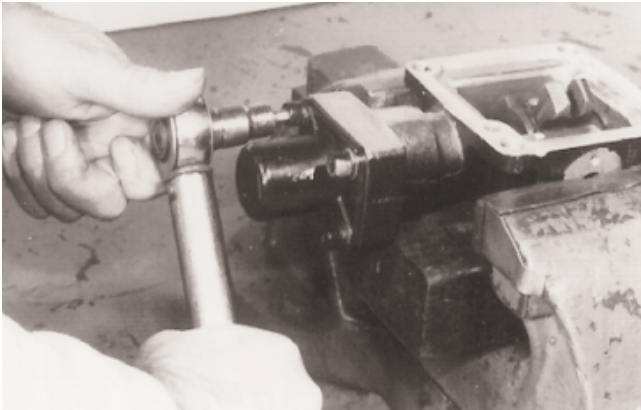

8. Apply sealant to the capscrews and tighten to the correct torque (20 to 24 Nm).

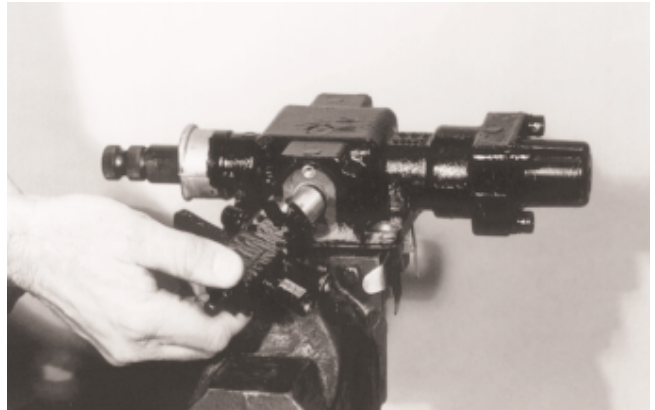

11. Apply sealant and fit the breather. Install the slave valve using a new gasket. Position the valve with the two outlet ports facing the left-hand side of the housing and tighten the socket headed bolts to the correct torque.

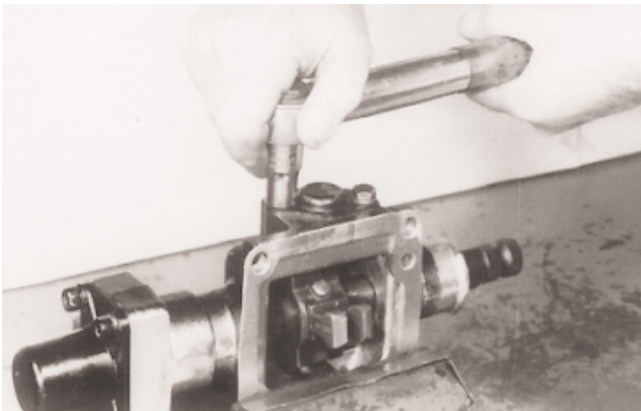

9. Support the housing assembly in the vice and install the reverse detent plunger and spring. Install the cover using a new gasket and tighten the retaining capscrews to the correct torque.

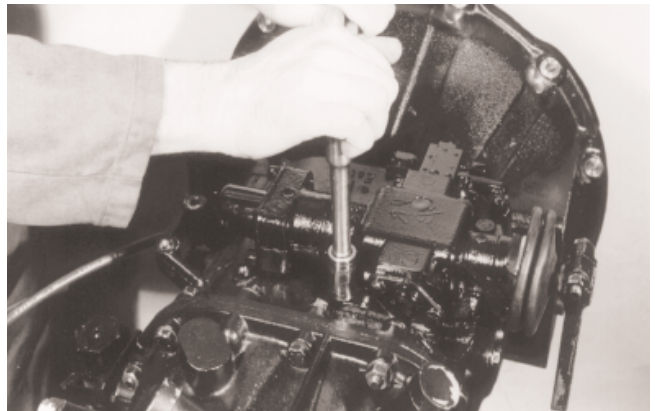

12. Apply flange sealant and install the remote control, making sure that the inner lever locates over the selector block. Fit and tighten the capscrews to the correct torque.

Section 4 Main Transmission Overhaul

Main Transmission overhaul

Transmission case - Exploded view (horizontal transmission)

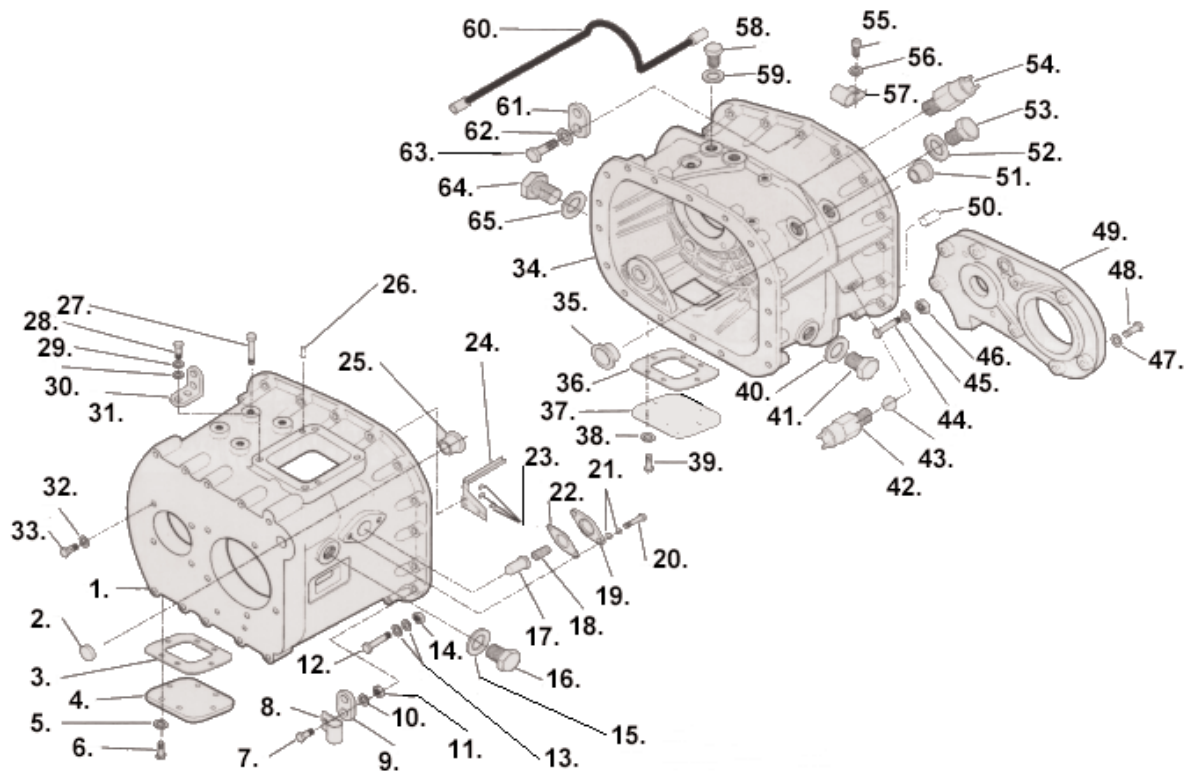

- | | | |
|----------------------|---------------------------------------|---------------------------------------|
| 1. Front case | 25. Bush | 48. Bolt M10 x 30 |
| 2. Plug | 26. Dowel | 49. Oil pump assembly |
| 3. Gasket | 27. Bolt M10 x 55 | 50. Dowel |
| 4. Cover | 28. Screw M10 x 35 | 51. Bush |
| 5. Spring washer M10 | 29. Washer M10 | 52. Washer |
| 6. Screw M10 x 20 | 30. Spring washer M10 | 53. Plug |
| 7. Screw M10 x 20 | 31. Lifting eye | 54. Reverse light switch/range switch |
| 8. Hose clamp | 32. Spring washer M12 | 55. Screw M10 x 20 |
| 9. Lifting eye | 33. Screw M12 x 25 | 56. Washer M10 |
| 10. Washer M10 | 34. Intermediate case | 57. Hose clamp |
| 11. Nut M10 | 35. Bush | 58. Plug |
| 12. Bolt M10 x 25 | 36. Gasket | 59. Washer |
| 13. Washer M10 | 37. Cover | 60. Spray bar |
| 14. Nut M10 | 38. Washer M10 | 61. Lifting eye |
| 15. Washer M16 | 39. Screw M10 x 20 | 62. Washer M10 |
| 16. Plug M16 | 40. Washer M24 | 63. Bolt M10 x 55 |
| 17. Plunger | 41. Filler plug | 64. Oil strainer |
| 18. Spring | 42. Reverse light switch/range switch | 65. Washer M40 |
| 19. Cover | 43. Ball | |
| 20. Screw M8 x 14 | 44. Bolt M10 x 55 | |
| 21. Spring washer M8 | 45. Washer M10 | |
| 22. Gasket | 46. Nut M10 | |
| 23. Screw | 47. Spring washer M10 | |
| 24. Oil trough | | |

Main Transmission Overhaul

Exploded view (vertical transmission)

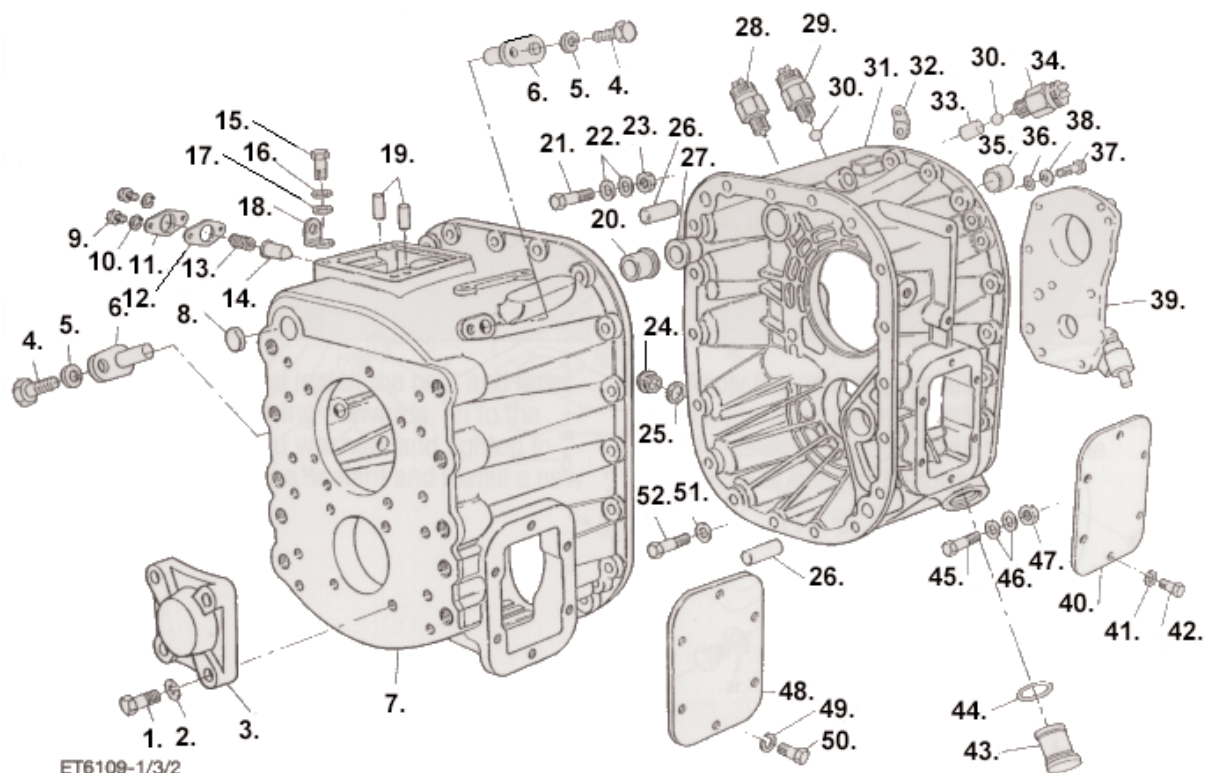

- | | | |
|------------------------------|---|-------------------------------|
| 1. Screw M12 x 25 | 22. Washer M10 | 41. Spring washer M10 |
| 2. Spring washer M12 | 23. Nut M10 | 42. Screw M10 x 20 |
| 3. Bearing cover | 24. Plug M24 | 43. Oil strainer assembly |
| 4. Screw M8 x 20 (overdrive) | 25. Washer M24 | 44. Washer |
| 5. Washer M8 (overdrive) | 26. Dowel | 45. Bolt M10 x 55 or M10 x 60 |
| 6. Rotation pin (overdrive) | 27. Bush | 46. Washer M10 |
| 7. Front case assembly | 28. Reverse switch (or plug and washer) | 47. Nut M10 x 1.5 |
| 8. Plug | 29. Neutral switch (or plug and washer) | 48. Cover |
| 9. Screw M8 x 14 | 30. Detent ball | 49. Spring washer M10 |
| 10. Spring washer M8 | 31. Intermediate case | 50. Screw M10 x 20 |
| 11. Cover | 32. Lifting eye | 51. Washer M10 |
| 12. Gasket | 33. Interlock pin | 52. Bolt M10 x 40 |
| 13. Spring | 34. Range switch (or plug and washer) | |
| 14. Plunger | 35. Bush | |
| 15. Screw M10 x 35 | 36. Washer | |
| 16. Spring washer M10 | 37. Bolt M10 x 30 | |
| 17. Washer M10 | 38. Spring washer M10 | |
| 18. Lifting eye | 39. Oil pump assembly | |
| 19. Dowel | 40. Cover | |
| 20. Bush | | |
| 21. Bolt M10 x 55 | | |

Main Transmission Overhaul

Disassembly

Caution: Drain the oil from the transmission and clean and refit the drain plugs and filler plugs.

Note: The transmission illustrated in this section is a standard ratio vertically installed unit. The procedure is the same for all transmissions but the physical size and number of teeth on some of the gears will vary from those illustrated on overdrive ratio models. Horizontally installed units have the remote control on the side of the transmission and alternative filler and drain plug positions.

It is recommended that the transmission is overhauled, mounted on the stand illustrated. If a stand is not available the transmission should be stood on wood blocks on the clutch housing until it is inverted. It should then be stood on the rear flange of the intermediate case on the blocks, taking great care not to damage the case flange, to complete the removal of the mainshaft.

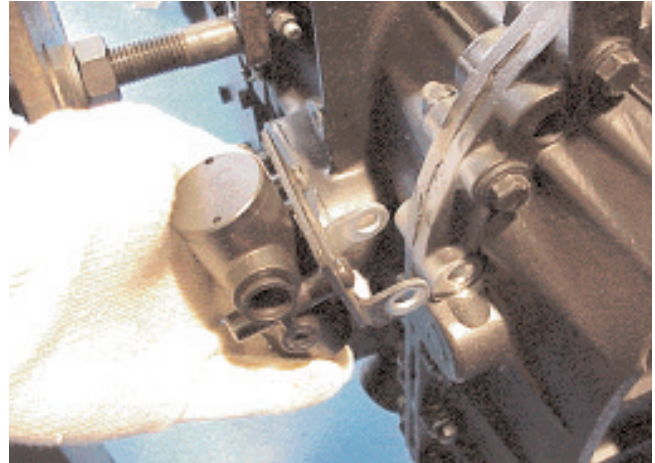

3. Remove the filter/pressure regulating valve and mounting bracket.



1. Using a hoist, mount the transmission onto the stand. Mark the hoses to ensure reassembly to the correct ports and disconnect the hoses from the transmission.

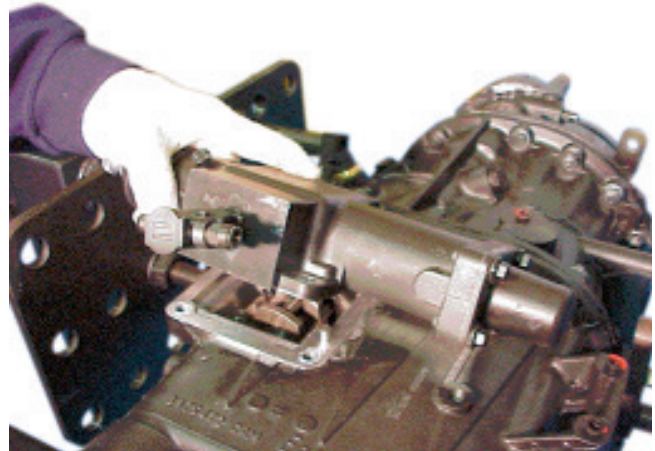

4. Ensure neutral is engaged and remove the remote control housing capscrews. Using a soft faced mallet if necessary, separate the housing from the transmission.



2. Remove the slave valve and mounting bracket (when mounted on the transmission). Protect the valve and hoses from dirt ingress.

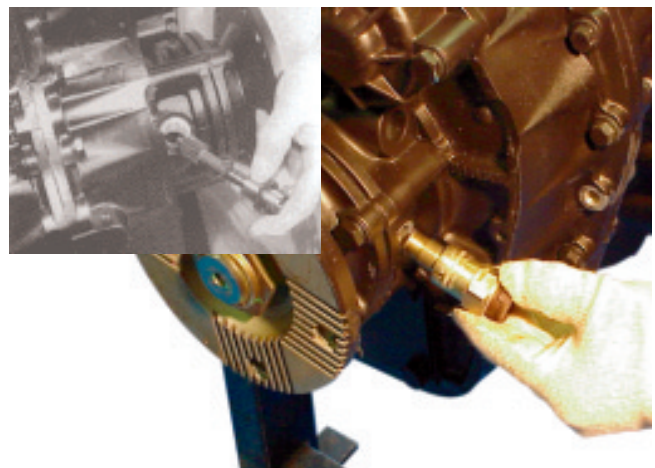

5. Remove the speedometer tachograph sender or, as fitted on some models, speedometer adaptor and drive pinion taking care not to damage any seals (see inset).

Main Transmission Overhaul



6. Using a flange holding wrench, slacken but **DO NOT REMOVE** the flange retaining nut. Break the retaining torque only. Remove the flange retaining tool.

Warning: Do not allow the output shaft to slide in the bearing or the range change synchroniser may spring apart.

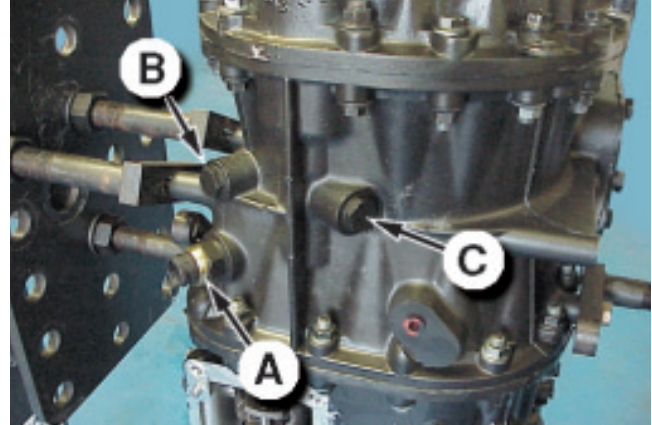

9. Remove the reverse lamp switch (A). Remove the range indicator (C) and neutral switches (B), collect the ball from each bore as the switches are removed. Use a magnet or tap the case gently to release the balls if necessary.



7. Rotate the transmission on the stand to the vertical position, rear end uppermost.



10. Remove the capscrews and nuts securing the rear end case to the intermediate case.



8. Unscrew and remove the oil strainer, remove and discard the O-ring (if fitted) and washer.
Note: A plug/washer only may be fitted on some multi-purpose specification transmissions fitted with an integral strainer.



11. Attach a sling and hoist to the output drive flange.
Note: Attach the sling so as to lift the rear case as near vertically as possible. Raise the hoist and separate the rear case from the intermediate case. Use a soft faced mallet if necessary to aid separation. Do not use pry bars or levers or the case flanges may be damaged.

Main Transmission Overhaul



12. Using the appropriate sun gear retaining tool to lock the sun gear, unscrew and remove the sun gear retaining bolt and the special washer.

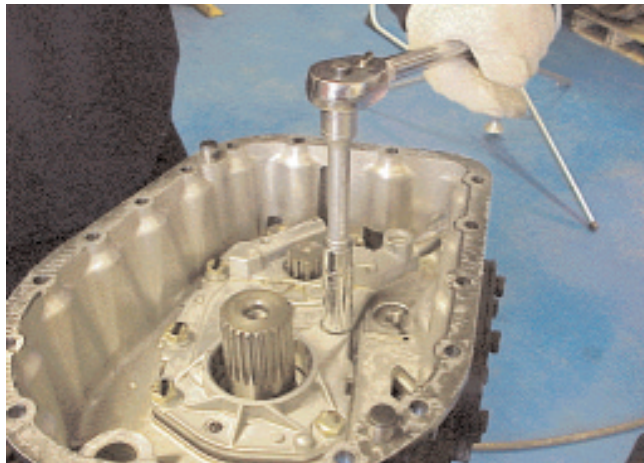

15. Remove the capscrews securing the oil pump assembly to the transmission. On some multi-purpose specification transmissions, the oil strainer assembly and bracket must be removed.



13. Lift off the sun gear.

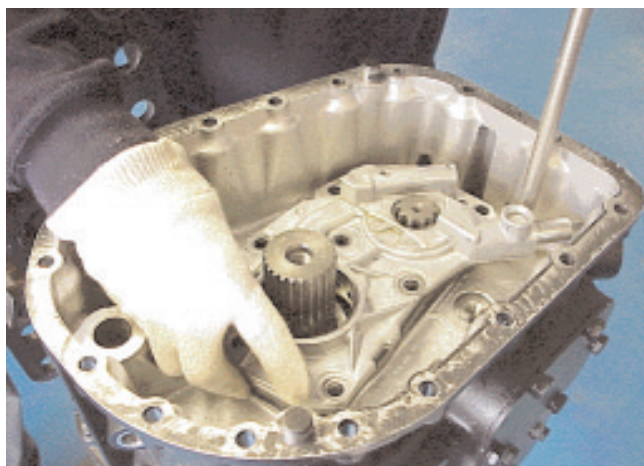

16. Using a pry bar under the lugs provided, prise the pump off the locating dowels. Lift out the pump assembly.



14. Lift out the muff ring taking care not to damage the two sealing rings.

Main Transmission Overhaul

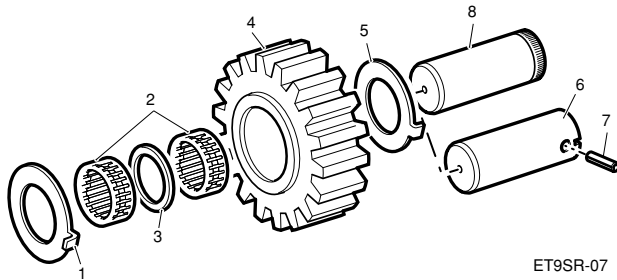

Reverse idler gear assembly

- | | |
|--------------------------|------------------------|
| 1. Thrust washer | 5. Thrust washer |
| 2. Needle roller bearing | 6. Shaft |
| 3. Spacer | 7. Parallel groove pin |
| 4. Gear, reverse idler | 8. Shaft |

17. Retention of the reverse idler shaft assembly is achieved by one of two methods. Current production units utilise a serrated idler shaft (item 8) whereas transmissions built prior to the introduction of the serrated idler shaft utilised a plain idler shaft with cross drilled hole (item 6) located by a retaining pin (item 7).

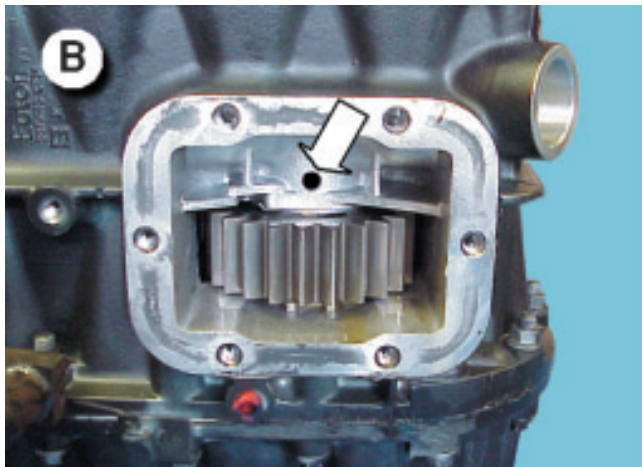

18. To establish which method of reverse idler shaft retention has been utilised it is necessary to remove the PTO cover and refer to the drilled hole. If a retaining pin can be seen then follow the next procedure. If retention is not achieved by use of a retaining pin then proceed to paragraph 20.

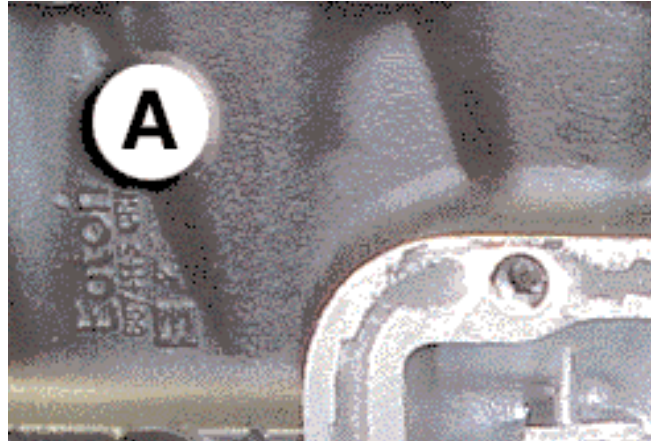

19. Using the tool E 117, or an 8 mm punch, drive the reverse idler gear shaft roll pin inwards until the end is approximately 12 mm from the face of the hole. Do not allow the pin to 'bottom' against the shaft bore.



20. Where fitted remove the circlip from the maincase. Screw the slide hammer MS284/E119 into the rear of the reverse idler gear shaft and withdraw the shaft from the case. Remove the pin from the shaft if fitted.

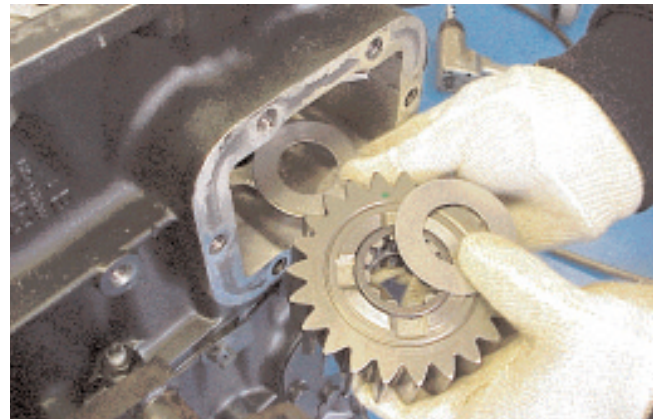

21. Remove the reverse idler gear and bearings and the two thrust washers from the case

Main Transmission Overhaul



22. Remove the mainshaft bearing thrust washer to prevent loss and invert the transmission assembly on the stand.
Note: If a ball bearing is fitted, the thrust washer cannot be removed at this point.

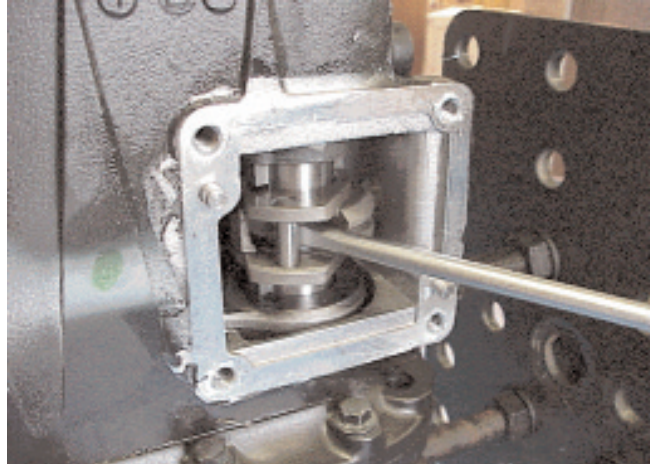

25. Rotate the gear selector shaft as far to the left (vertically mounted) or right (horizontally mounted) so that the front case will not foul the selector block on removal.

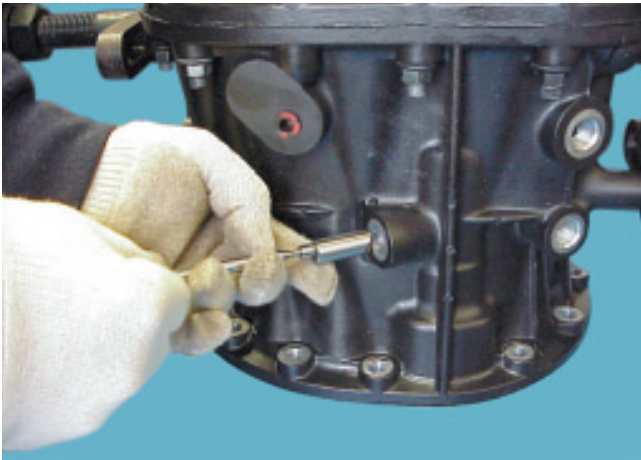

23. Collect the range change/selector shaft interlock pin, located in the bore between the selector rods, as the transmission is inverted using a magnet if necessary.



26. On overdrive models, remove the capscrews retaining the two overdrive fork pivot pins and remove the pins.



24. Remove the detent spring cover plate, spring and plunger or screw-in detent assembly from the front case. Certain specifications have a range inhibitor valve fitted over the detent cover.

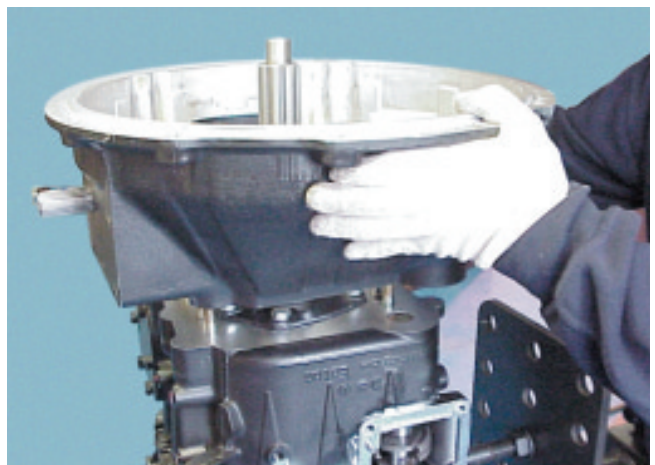

27. Remove the clutch housing

Main Transmission Overhaul



28. Remove cap screws and nuts securing the front case to the intermediate case. Note the position of the shorter cap screws threaded into the case. Horizontal transmissions have a spray bar locating screw on the front face of the front case. Remove this screw before removing the front case.

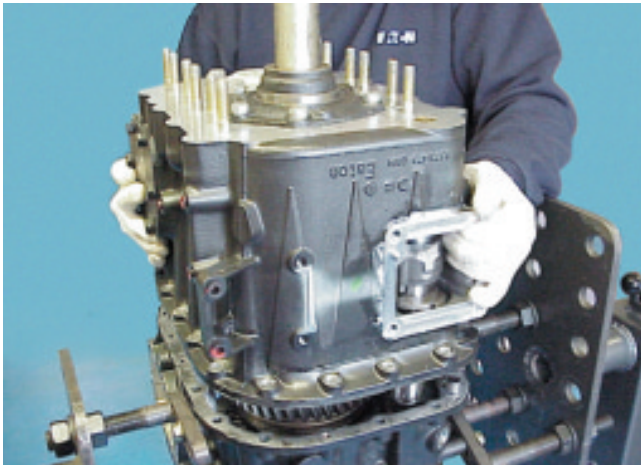

29. Using a soft faced mallet to break the compound seal, separate the front half case (complete with the input shaft) from the intermediate case do not use pry bars or chisels to separate the case or the flanges may be damaged.

Note: If difficulty is experienced separating the two casing halves the input shaft synchroniser flange may have become fixed to the shaft. Should this occur, remove the input shaft cover and bearing outer snap ring, and while lifting the front case half, tap the input shaft with a soft faced mallet to drive the shaft and bearing through the case bore.



30. Remove the spigot bearing. On horizontal transmissions a restrictor is fitted to the roll pin in the end of the mainshaft.

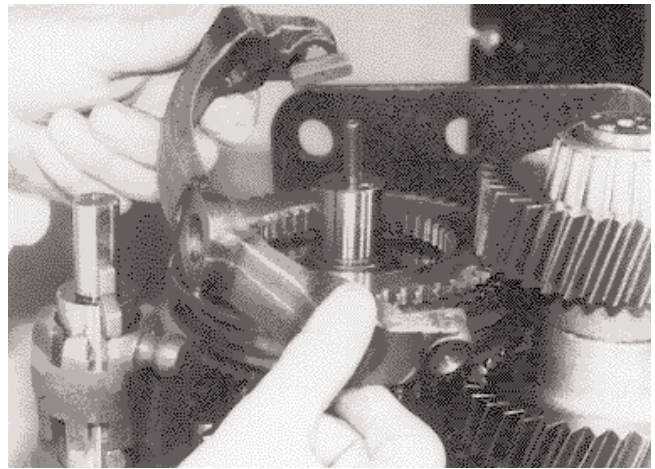

31. On the overdrive models, to prevent loss or damage, disengage and remove the overdrive fork assembly from the 3rd/4th gear synchroniser sleeve and selector. Take care not to lose the selector pads.

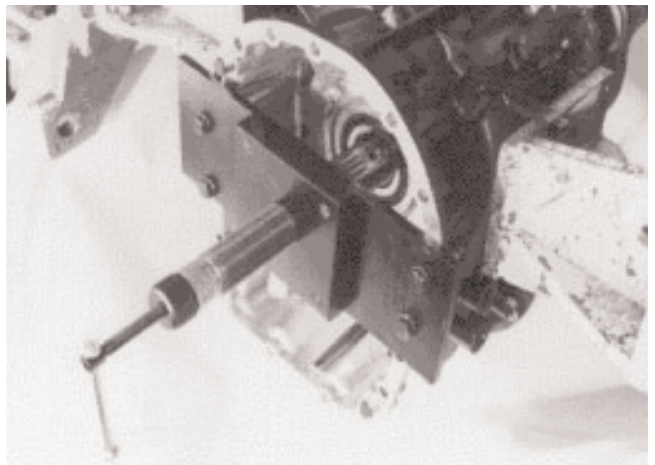

32. On transmissions fitted with a ball bearing in the rear mainshaft position, use the locally made tool to release the inner race.

Main Transmission Overhaul

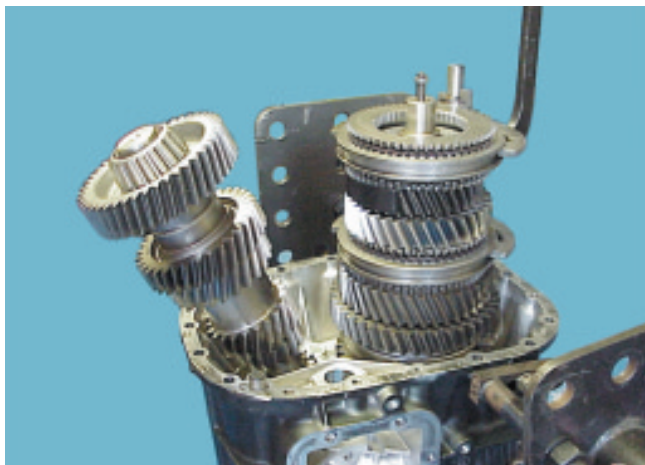

33. Assemble the tools E 116A and E 116-1 under the 3rd/4th gear synchroniser hub assembly and using the hoist raise the shaft approximately 10 to 20 mm. This allows the layshaft to tilt clear of the mainshaft.



36. Drift out the mainshaft rear bearing from the case using a suitable tool. Do not allow the bearing to fall to the floor.

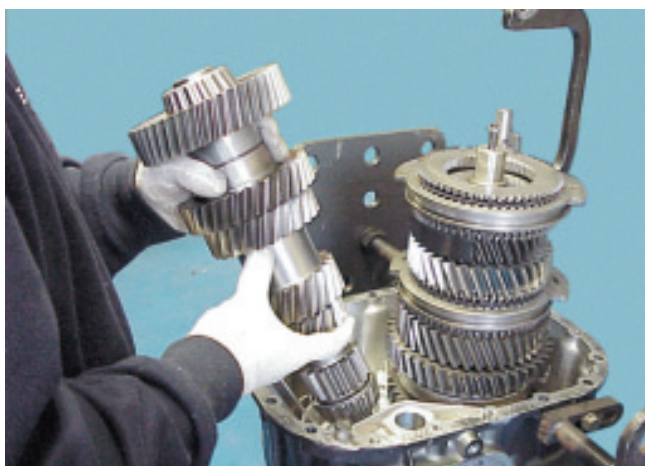

34. Lift out the layshaft.

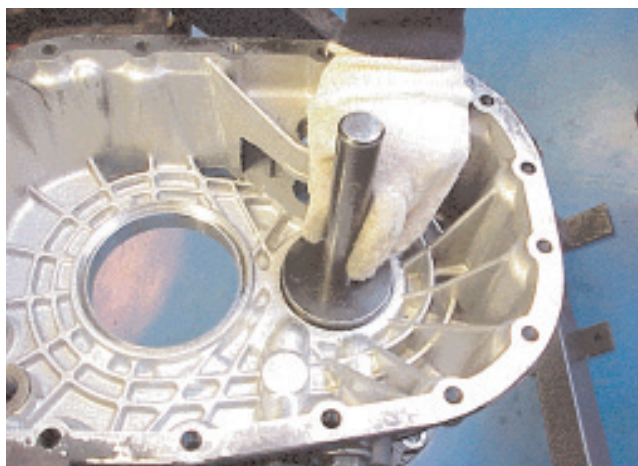

37. Drift out the layshaft rear bearing and bearing spacer (where fitted)



35. Raise the hoist and lift out the mainshaft and selector shaft as an assembly. Carefully lower onto a clean bench and remove the tool. Separate the selector shaft and forks from the mainshaft.



38. Remove and replace the selector shaft bush if necessary.

Main Transmission Overhaul



39. Replace the range change shaft bush if necessary.

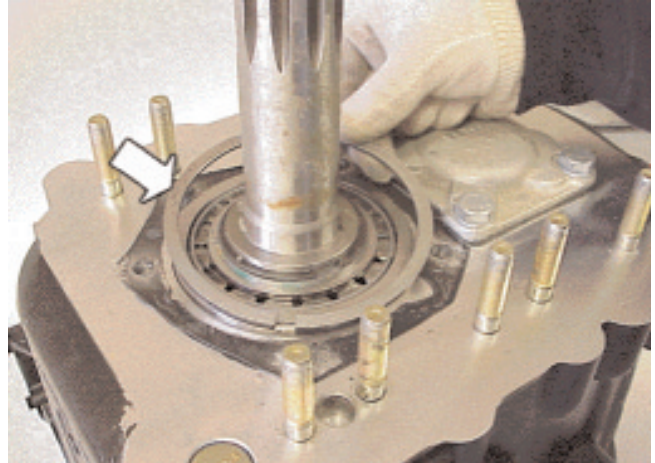

42. On overdrive models remove the input shaft bearing outer snap ring.

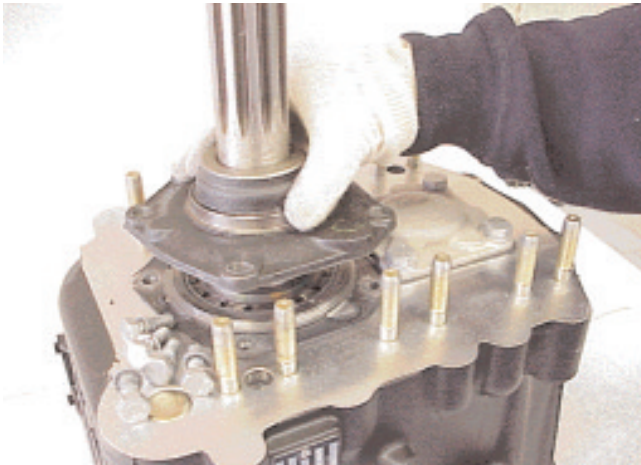

40. Remove the capscrews securing the input shaft cover to the front case half. Remove the cover.



43. Use a soft faced mallet to drive the shaft through the case taking care not to allow the shaft to fall and become damaged.



41. On direct drive models remove the input shaft and bearing assembly. Certain specifications have an O-ring seal/plate which must be removed before removing the input shaft cover.

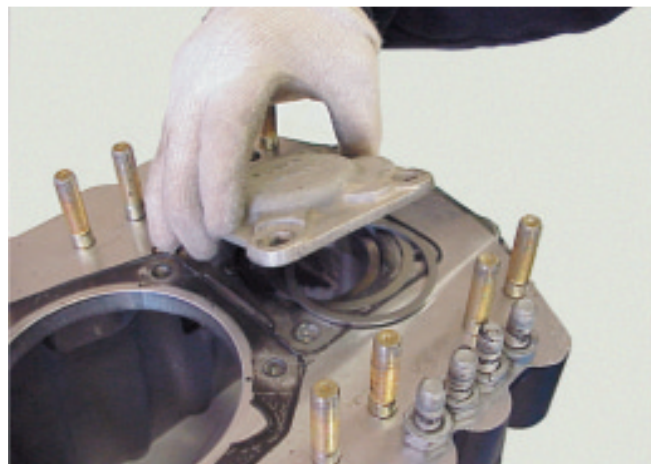

44. Remove the layshaft front bearing retaining plate and graded spacer from the front case half.

Main Transmission Overhaul

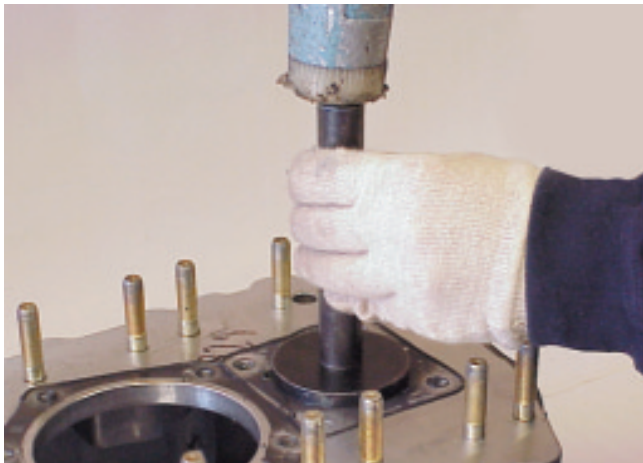

45. Drift out the layshaft front bearing cup using a suitable tool.

Main Transmission Overhaul

Casing bushes - Renewal

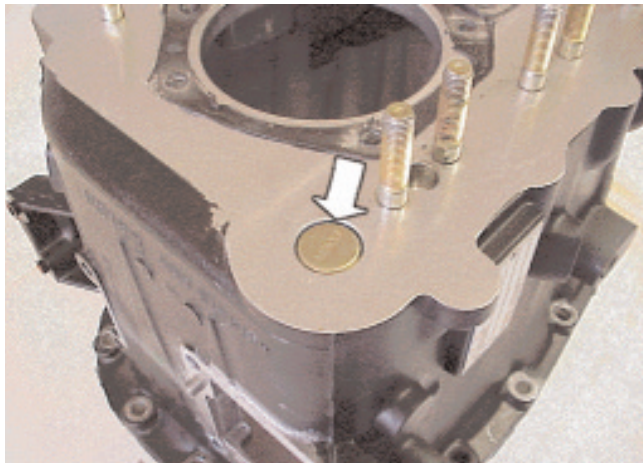

46. If the selector shaft bushes are to be replaced drive the core plug from the front case using a suitable tool. Note; Drive the core plug from inside of the front case.



49. Fit the selector shaft bushes to the front and intermediate cases ensuring that they are fully seated.

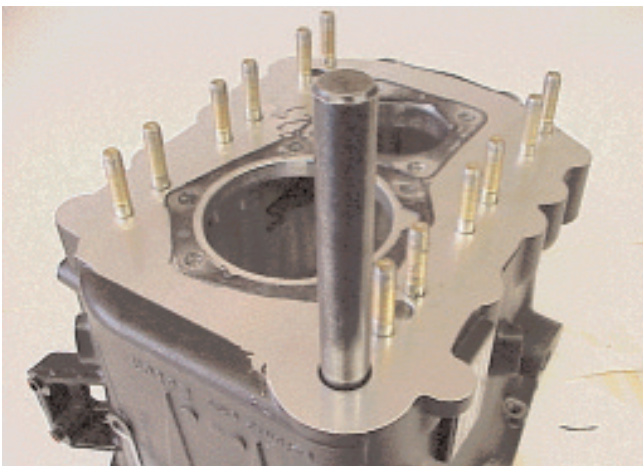

47. Drive the selector shaft bush from the front case from the outside. Drive the selector shaft bush from the intermediate case by driving the bush forwards.

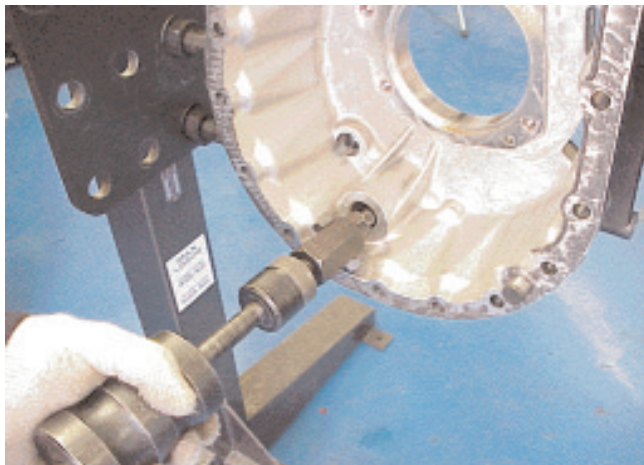

50. Range change selector rod bush - intermediate case. Remove the bush toward the rear using an internal type extractor.

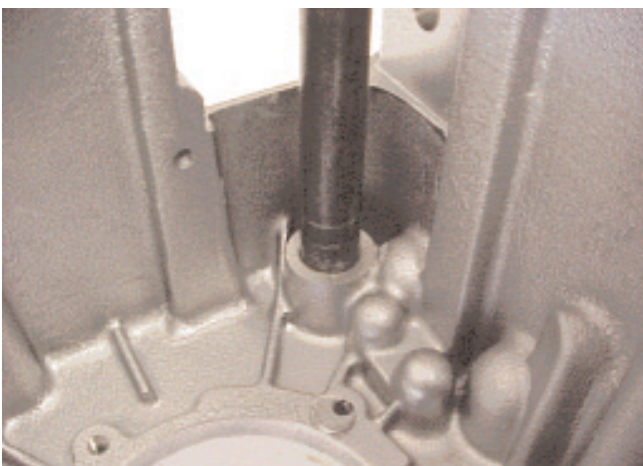

48. Apply a coating of sealant to the core plug. Drive it in, from the inside the front case, until it is flush with the front case face.



51. Install the new bush until flush with the face of the case bore using tool E 109-5. The bush is prefinished to the correct size. Remove any burrs from the edge of the bush using a fine file or slip stone and check the fit of the selector rod in the bore.

Main Transmission Overhaul

Rear case - Exploded view

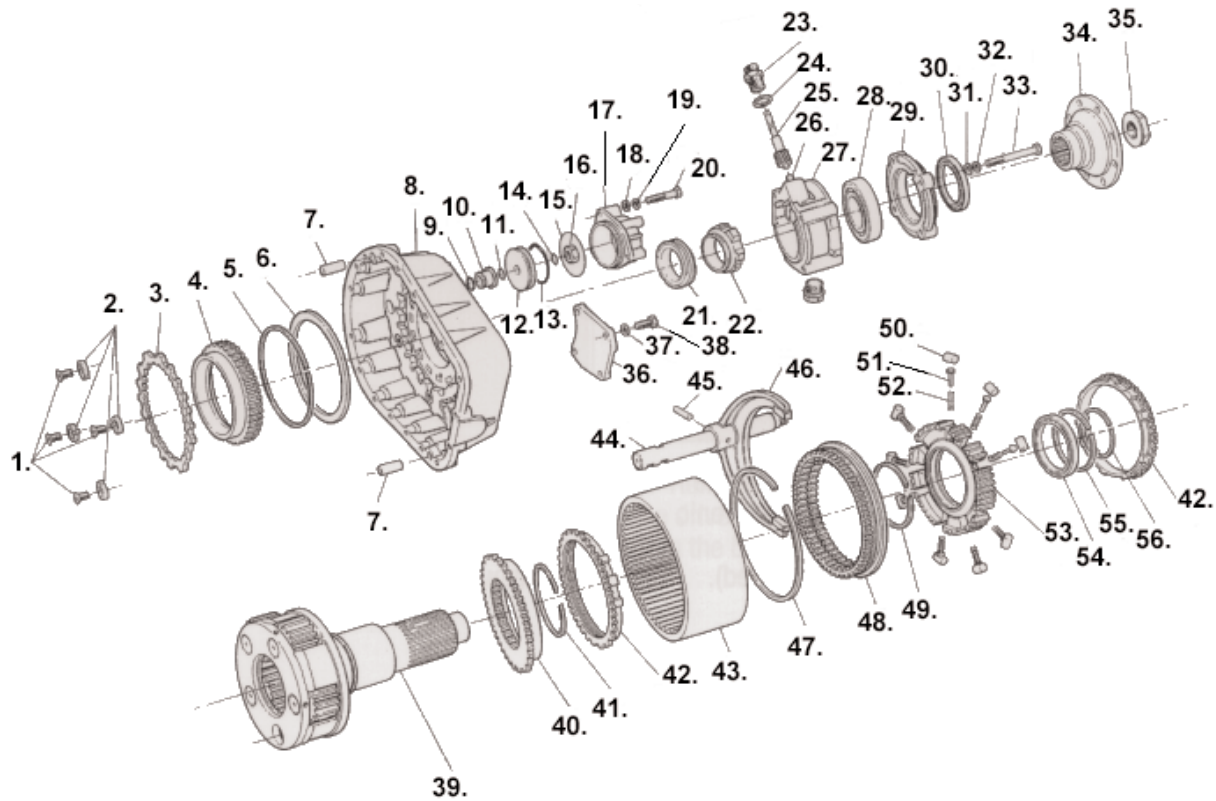

- | | | |
|----------------------------|------------------------------------|------------------------------|
| 1. Screw M8 x 20 | 20. Bolt M10 x 60 | 39. Planet carrier assembly |
| 2. Reaction plate retainer | 21. Speedo drive gear | 40. Synchro flange |
| 3. Reaction plate | 22. Spacer/rotor | 41. Circlip |
| 4. Synchro flange, range | 23. Adaptor bush/oil seal assembly | 42. Synchro ring, range |
| 5. Circlip | 24. Washer | 43. Gear annulus |
| 6. Spacer | 25. Speedo pinion | 44. Range shift rod |
| 7. Dowel 16 dia x 30 | 26. Bush | 45. Grooved pin |
| 8. Rear case | 27. Speedo housing | 46. Range shift fork |
| 9. O-Ring | 28. Bearing | 47. Circlip |
| 10. Bush | 29. Rear cover, oil seal | 48. Sliding sleeve, range |
| 11. O-Ring | 30. Oil seal | 49. Circlip |
| 12. Range piston | 31. Washer M10 | 50. Synchro plunger |
| 13. Range piston O-Ring | 32. Spring washer | 51. Synchro plunger |
| 14. Range bar O-Ring | 33. Bolt M10 x 100 | 52. Compression spring |
| 15. Rangecover O-Ring | 34. Output flange | 53. Fixed hub, synchro range |
| 16. Nut M16 | 35. Nyloc nut M39 | 54. Bearing, synchro hub |
| 17. Range cylinder | 36. Rear PTO cover | 55. Circlip |
| 18. Washer M10 | 37. Spring washer M12 | 56. Circlip |
| 19. Spring washer M10 | 38. Screw M12 x 25 | |

Main Transmission Overhaul

Disassembly



1. Support the rear case assembly on a suitable clean block or spacer under the range change epicyclic. Remove the capscrews securing the range change cylinder cover to the rear case and remove the cover.

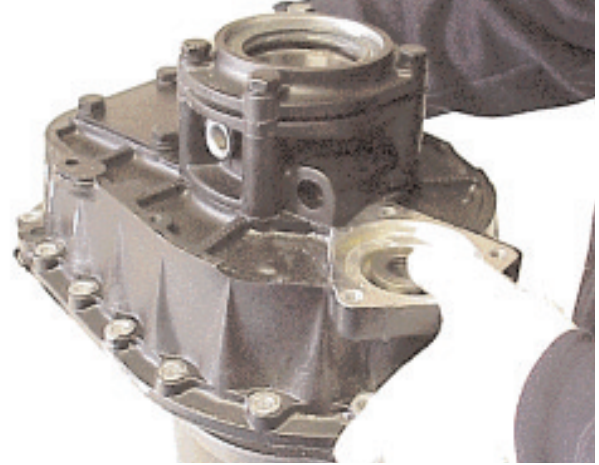

4. Carefully lift the case allowing the output shaft to slide out of the bearing and the range change selector rod to slide out of the bush.



2. Remove the nut retaining the range change piston to the shaft. Remove the piston.



5. Remove the selector fork assembly from the synchroniser sliding sleeve.



3. Remove the output drive flange retaining nut and the drive flange. Note that the flange boss is a close fit in the bearing inner track.



6. Lift off the electronic tachograph sensor ring and spacer or the speedometer drive gear and spacer (as fitted).

Main Transmission Overhaul



7. Lift off the synchroniser ring.

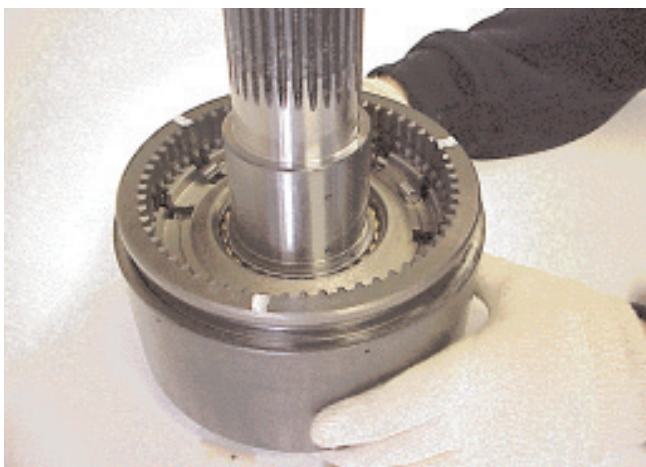

8. Put identifying marks on the synchroniser sliding sleeve in line with the synchroniser plungers, if not already marked, and remove the sleeve and annulus assembly. Note the position of the spring plungers and rollers and remove them from the hub.

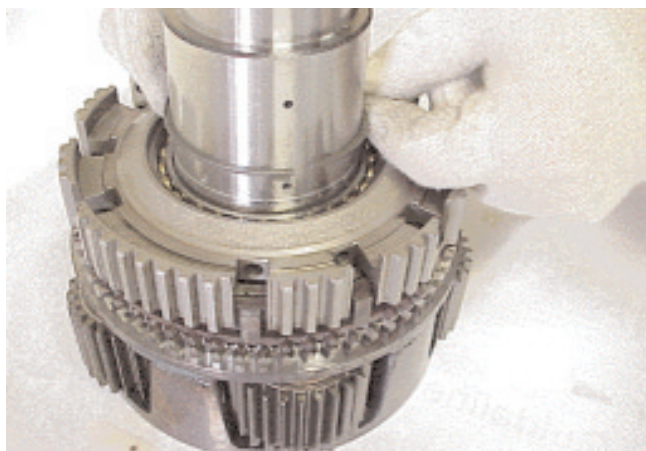

9. Remove the snap ring securing the synchroniser hub bearing to the output shaft.

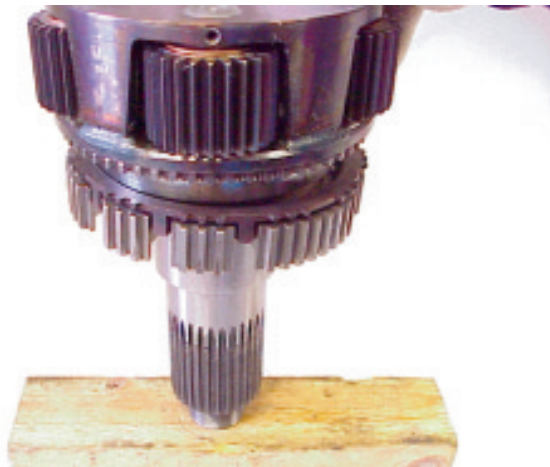

10. Invert the assembly and while restraining the hub, drop the end of the shaft onto a stout wood block to shock the hub, bearing assembly and synchroniser ring off the shaft.

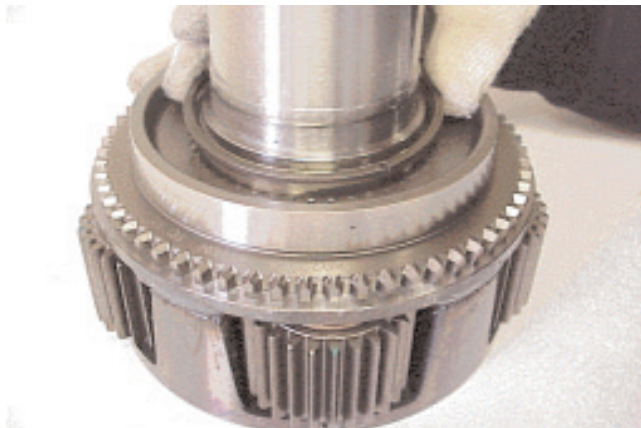

11. Remove the snap ring securing the synchroniser flange to the planet carrier.



12. Remove the synchroniser flange.

Main Transmission Overhaul



13. Remove the socket headed countersunk screws and special washers retaining the rear 'low' synchroniser flange and reaction plate to the rear case.



16. If necessary remove the special snap ring from the synchroniser flange.

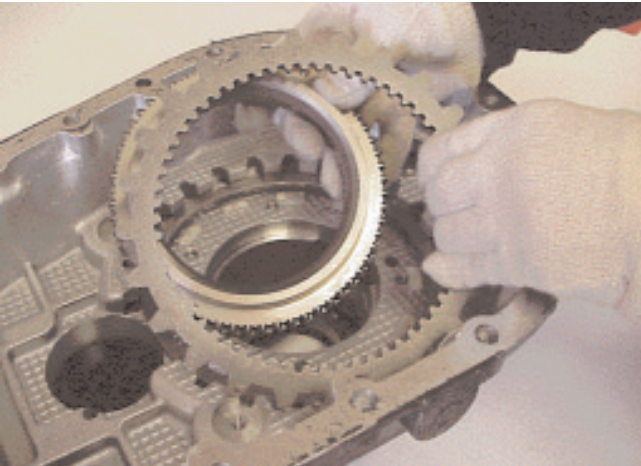

14. Lift out the reaction plate and the rear (low) synchroniser flange.

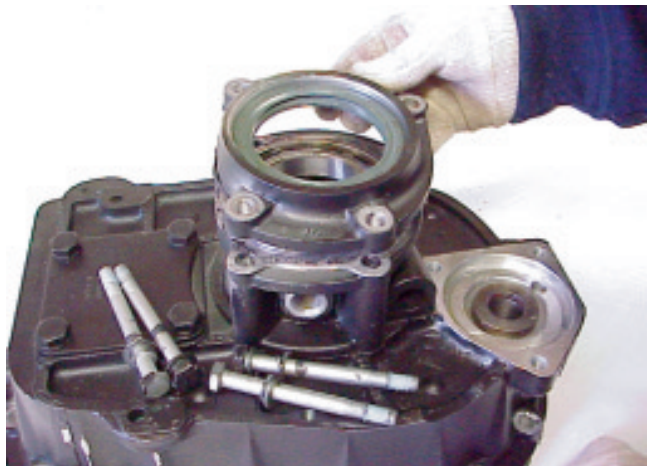

17. Remove the four capscrews retaining the oil seal carrier and the output shaft bearing housing, remove the oil seal carrier.

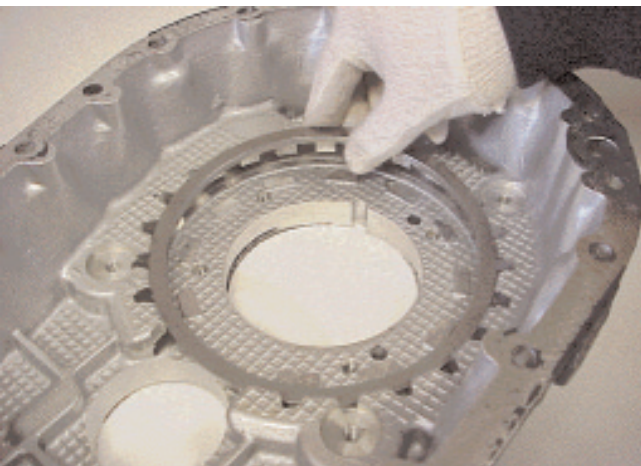

15. Lift out the spacer plate. On some multi-purpose specification transmissions an additional oil seal may be fitted in the rear case.



18. Remove the bearing housing.

Main Transmission Overhaul



19. If necessary drive the bearing out of the housing using a suitable drift.



22. Tighten a large (air cleaner) hose clip around the rivets or pins to compress the internal snap ring into the sliding sleeve.

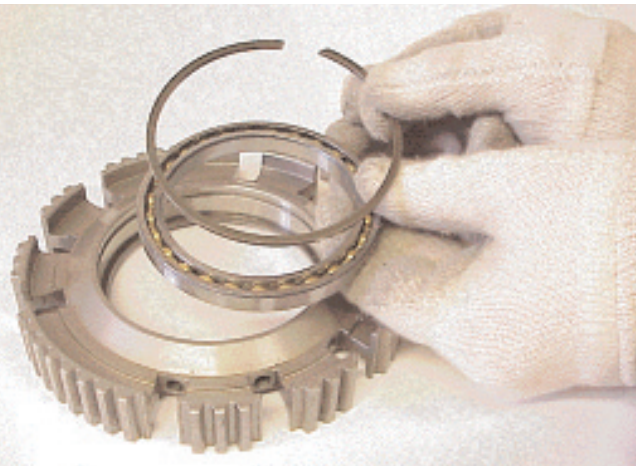

20. If necessary remove the bearing retaining snap ring from the range change synchroniser hub and remove the bearing.



23. Slide the sliding sleeve from the annulus.



21. To separate the annulus from the sliding sleeve, insert a rivet or steel pin, approximately 2-2.3 mm diameter and 10 mm long, into at least three of the holes in the annulus ensuring they are abutting the internal snap ring.



24. Separate the range change selector fork from the piston rod by drifting out the grooved pin with a suitable punch.

Main Transmission Overhaul



25. Remove the rear PTO cover plate from the rear of the rear case. Unscrew the air supply adaptors from the rear case.

Planet gear carrier - Exploded view

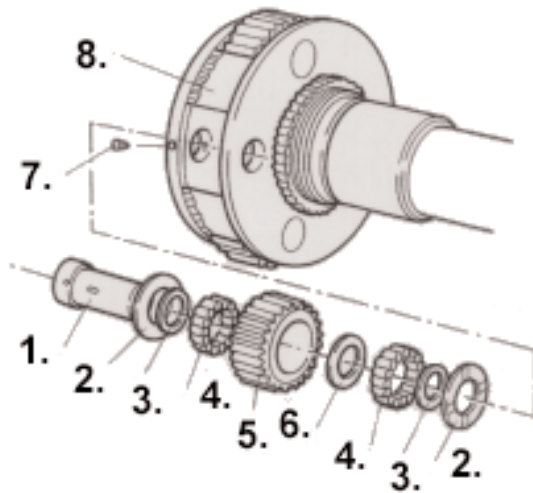

ET6109-7/3/1

Planet gear and bearings

1. Planet gear spindle
2. Thrust washer
3. Thrust washer
4. Needle roller
5. Planet gear
6. Spacer
7. Grub screw
8. Output shaft and planet carrier

Disassembly



1. Remove the bearing spindle retaining screws from the planet gear carrier. The screws are peened so that the area around the screw has to be drilled out before the screw is removed.

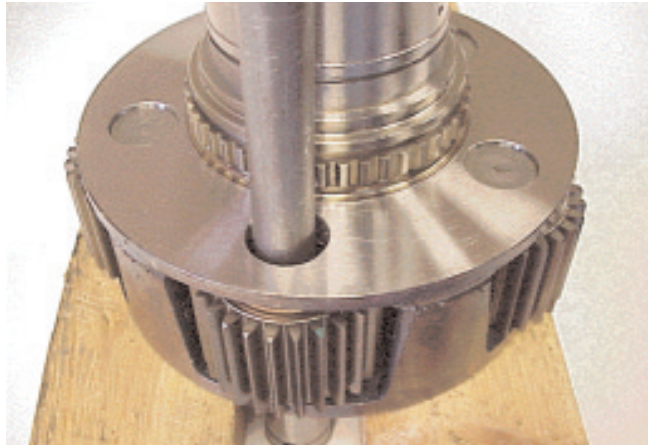

2. Using a soft faced mallet and suitable drift, drive the bearing spindle out of the carrier in the direction illustrated. **Note:** The spindle is shouldered and **MUST NOT** be driven the other way.

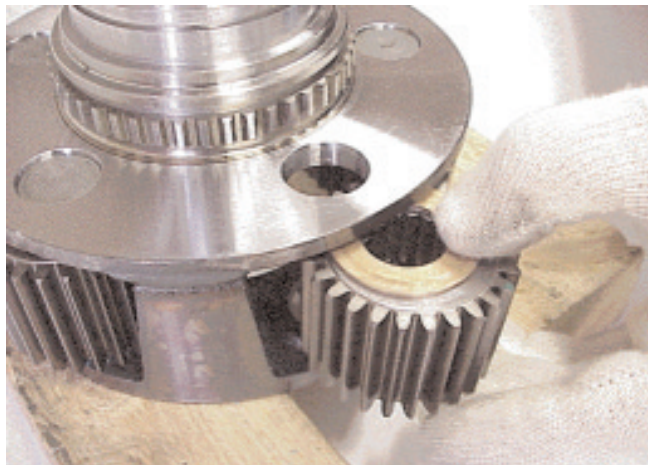

3. Slide the gear, bearing rollers, spacers and thrust washers from the carrier. Repeat these operations for the other four gears.

Main Transmission Overhaul Reassembly

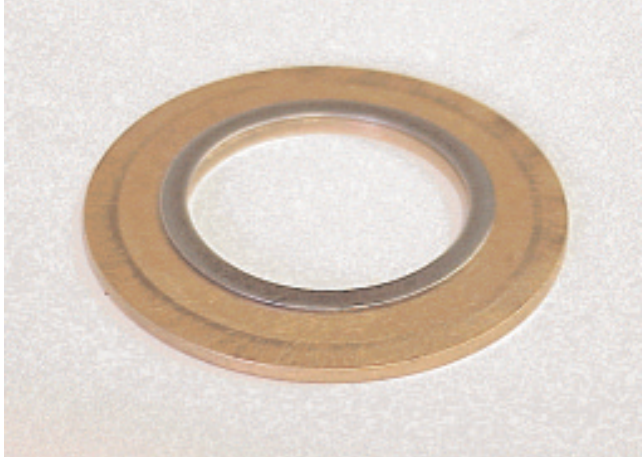

1. Place one thrust washer, grooved face uppermost, and one shim on a flat plate.



4. Place the spacer into position.



2. Place the gear onto the thrust washer. Apply a coating of petroleum jelly to the bore of the gear.

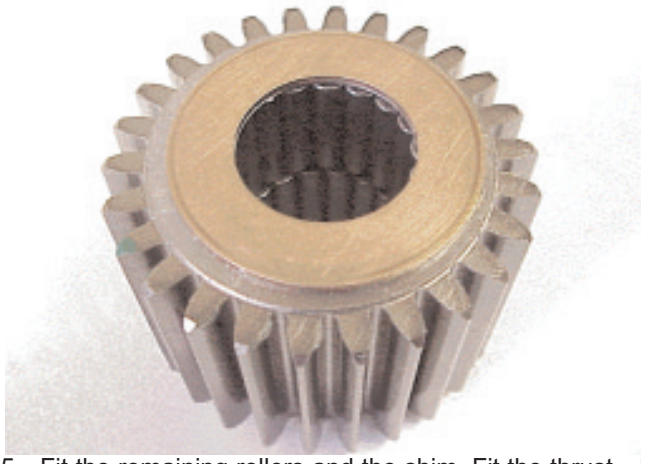

5. Fit the remaining rollers and the shim. Fit the thrust washer, grooved side downwards.



3. Place half the total quantity of rollers into position.



6. Support the output shaft in a soft jawed vice, planet carrier uppermost and slide the assembled gear into position in the carrier.

Main Transmission Overhaul



7. Slide in the gear assembly until the bore of the planet carrier and gear assembly align.

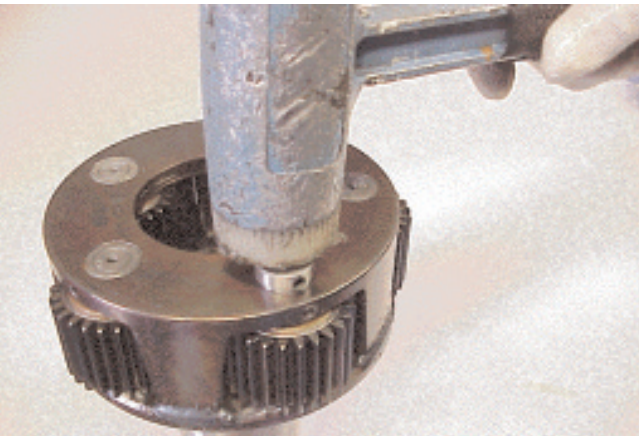

8. Ensure the locating hole in the spindle aligns with the hole in the carrier and drive the spindle into the carrier using a soft faced mallet.

Note: There is a lubrication hole directly opposite the locating hole. Do not align the wrong holes.

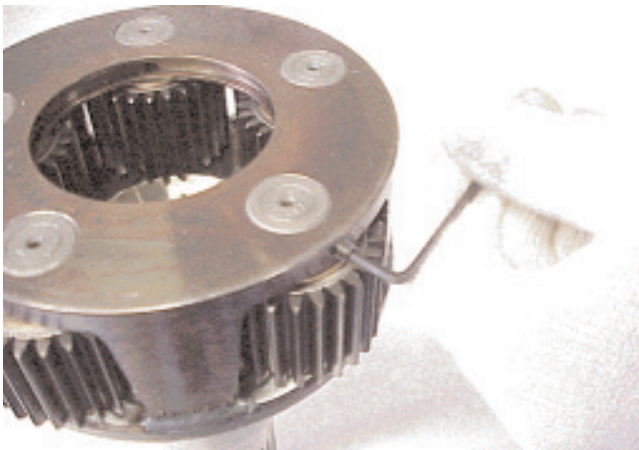

9. Ensure the threads are clean and dry and install a new locating grub screw, using thread locking sealer Loctite 270. Tighten to the correct torque and repeen with a suitable drift. Repeat sub-operations 1-9 for the remaining gears.

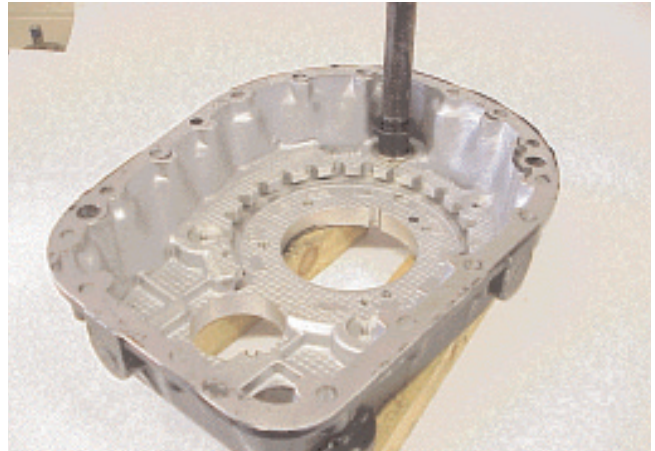

10. Range change selector rod bush - rear case. Drift out the rear bush complete with carrier from the rear case.



11. Install a new O-ring into the groove on the outer periphery of the bush carrier. Lubricate sparingly with silicone grease

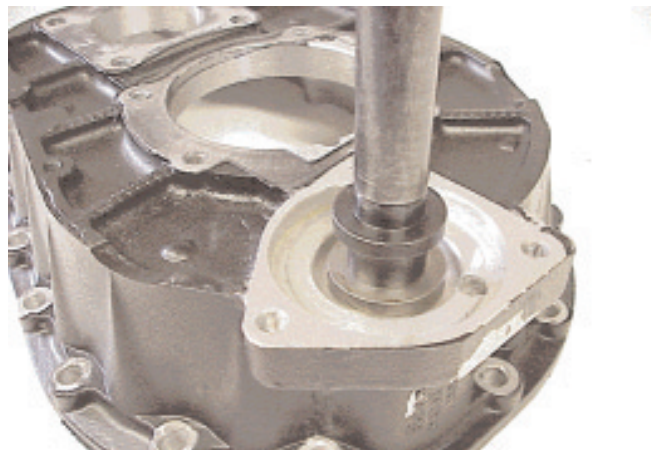

12. Install the bush carrier until the O-ring has just entered the case. Wipe off any surplus grease and apply sealer (Loctite 641) around the exposed part of the bush carrier and drive it into the case using tool E 109-5.

Main Transmission Overhaul

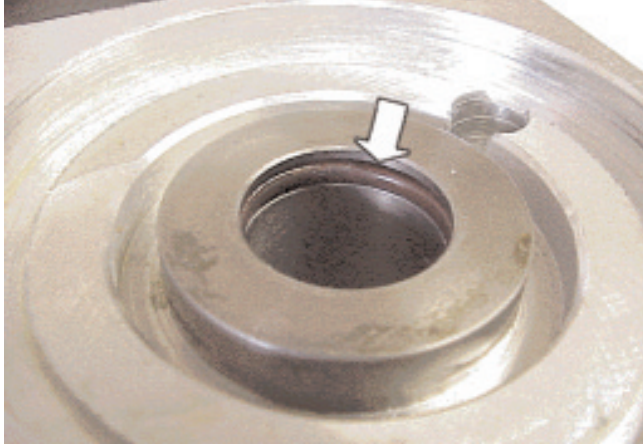

13. Install a new O-ring into the range change selector rod rear bush carrier. Lubricate with silicone grease.

Rear case reassembly

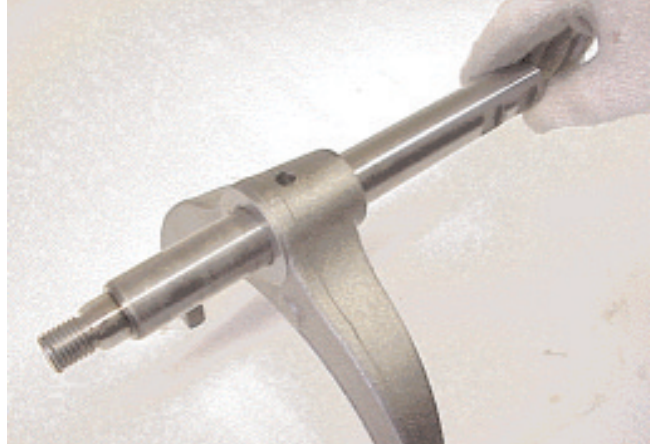

1. Support the range change selector fork and install the selector rod, threaded end to the plain side of the fork

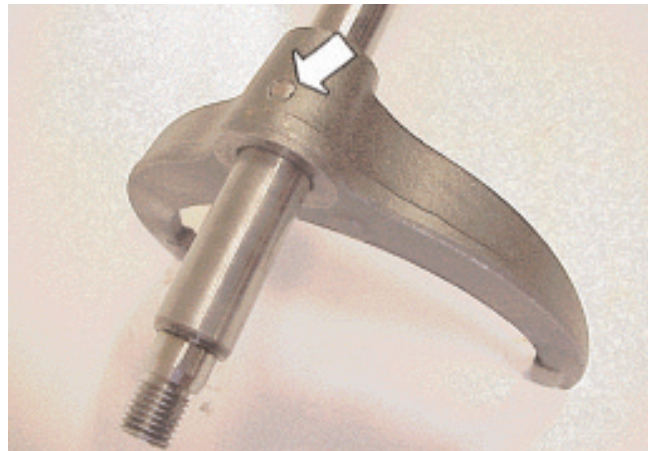

2. Align the retaining pin holes so that with the threaded end of the selector shaft to the left, the interlock detents are facing you. Install a new grooved pin.



3. Install the snap ring into the range change synchroniser hub and place the bearing into the hub against the snap ring.

Main Transmission Overhaul

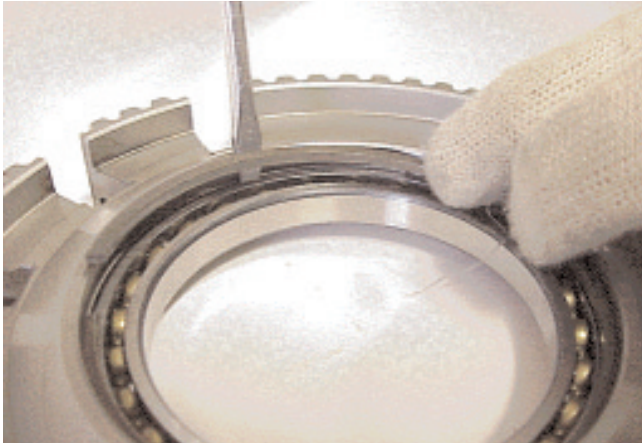

4. Install the second snap ring to retain the bearing in the hub



7. Stand the output shaft assembly on a firm support or block approximately 100 mm thick and place the synchroniser flange over the locating splines. Install the retaining snap ring.

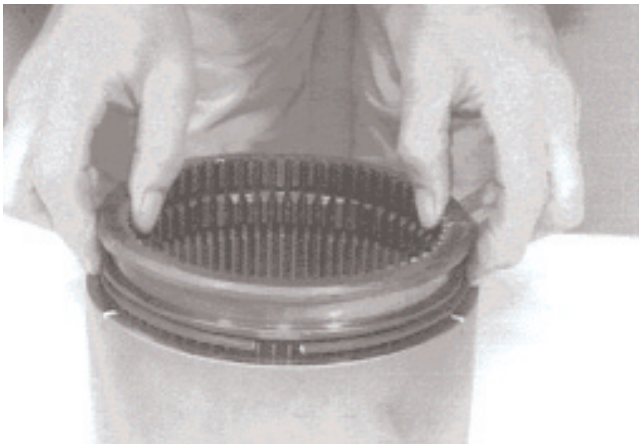

5. Stand the annulus, plain end down, on a clean bench. Locate the snap ring in the synchroniser sleeve, place the sleeve in the annulus and align the snap ring so that the ends are positioned midway between any two holes in the annulus.



8. Place the synchroniser ring over the synchroniser flange. Press the cone firmly down and, using feeler gauges, measure the clearance between the ring and the flange. Renew the flange and ring if the clearance is not within specification. Lubricate the synchroniser ring and flange.

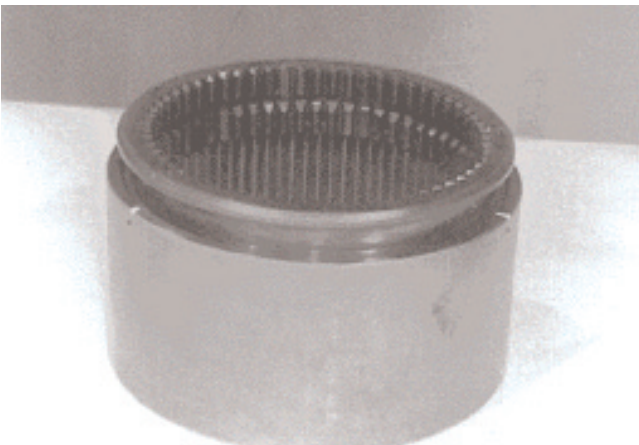

6. Compress the snap ring and push the sleeve into the annulus until the snap ring expands into the annulus locking the two parts together. If necessary use a hose clip to compress the snap ring.



9. Place the synchroniser hub and bearing assembly onto the shaft aligning the slots in the hub with the shoulders on the synchroniser ring. Use a soft mallet and drift or mandrel to ensure the bearing is fully home against the stop.

Main Transmission Overhaul



10. Install the retaining snap ring.



13. Remove the support lower the sleeve and ensure that the rollers are sitting in the groove of the synchroniser sleeve. Fit the rollers into the central slot of each set of grooves of the synchroniser hub.



11. Install the plungers and springs in the slots and slide the annulus and sliding sleeve assembly over the planet gears, aligning the marks on the sleeve and the middle slot of each group of three in the hub



14. Place the low synchroniser ring into the synchroniser hub ensuring that the bosses on the synchroniser ring locate in slots of the synchroniser hub. Lubricate the synchroniser ring with transmission oil.



12. Support the sleeve in the slightly raised position (approximately 15mm). Install the rollers into the outer slots of each set of grooves on the synchroniser hub.

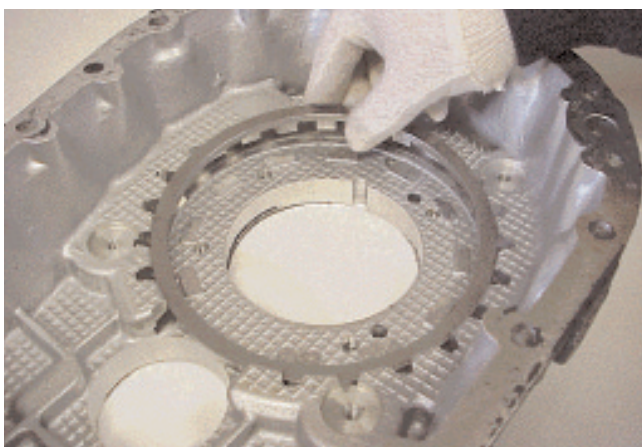

15. Support the rear case on wooden blocks and place the spacer ring into the recess in the rear case.

Main Transmission Overhaul



16. Install the large snap ring into the slot around the outer periphery of the low synchroniser flange.

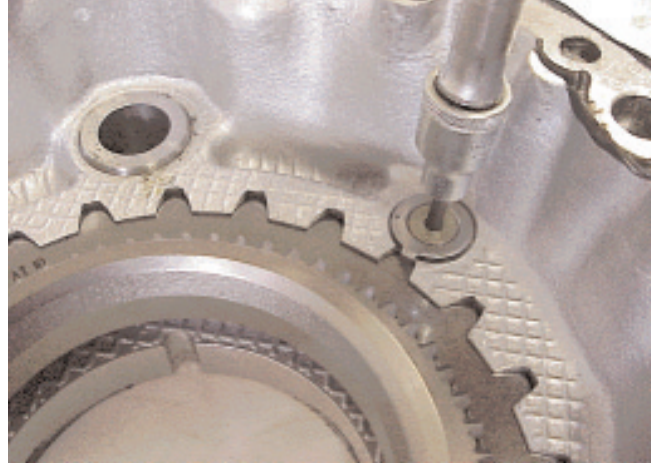

19. Install the three / four locating plates and screws. Tighten the screws to the correct torque.



17. Place the synchroniser flange and snap ring onto the spacer ring. On some multi-purpose specification transmissions an additional oil seal should be fitted in the rear case. This should not block off the oil feed hole in the output shaft.

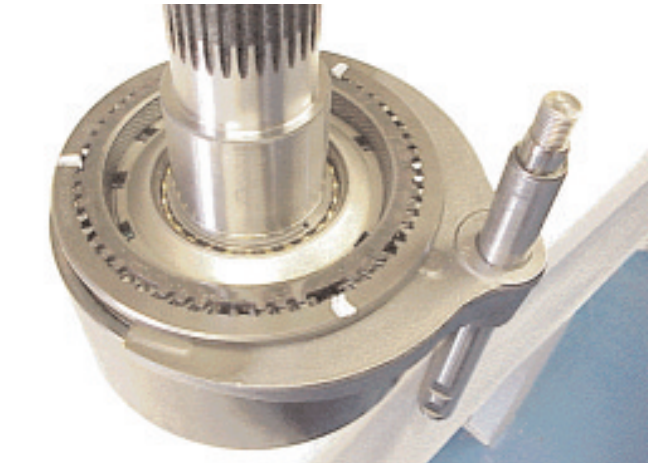

20. Locate the selector fork and shaft assembly into the synchroniser sleeve, threaded end of shaft uppermost.



18. Place the reaction plate over the synchroniser flange splines.



21. Invert the partly assembled case, ensure that the selector shaft bore O-ring is in position and lubricated with silicone grease and locate the case over the output shaft and selector rod.

Main Transmission Overhaul

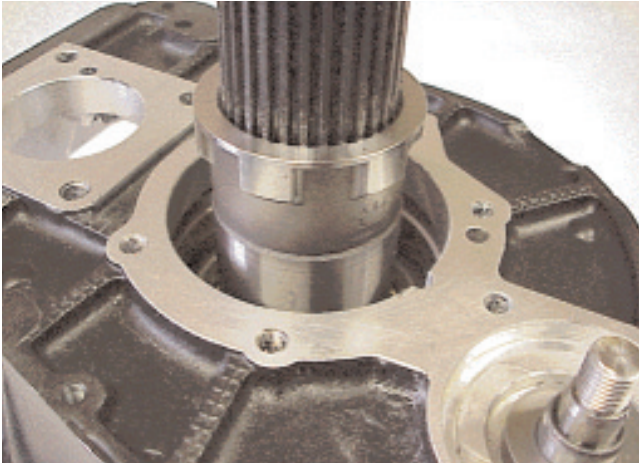

22. Place the speedometer drive gear/spacer over the output shaft. Where a combined drive gear / spacer is not used follow next two procedures.

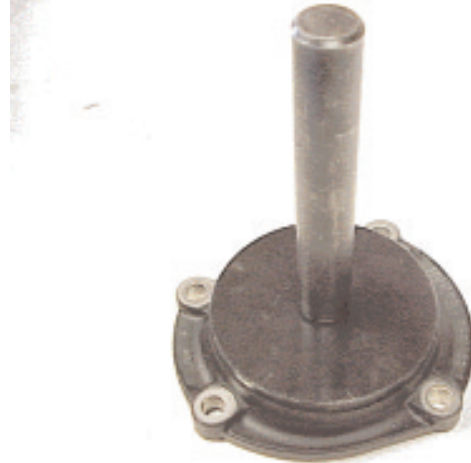

25. Install a new oil seal into the carrier using tool E109-12.

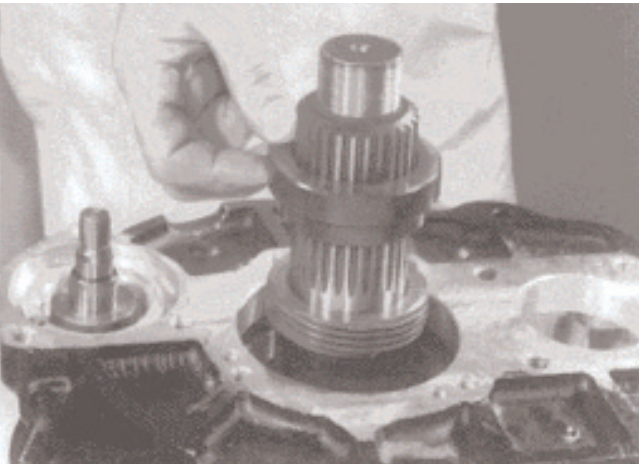

23. Place the tachograph sensor ring or spacer over the output shaft.

Note: an equivalent thickness spacer must be used if either the speedo gear or sensor ring is not fitted.

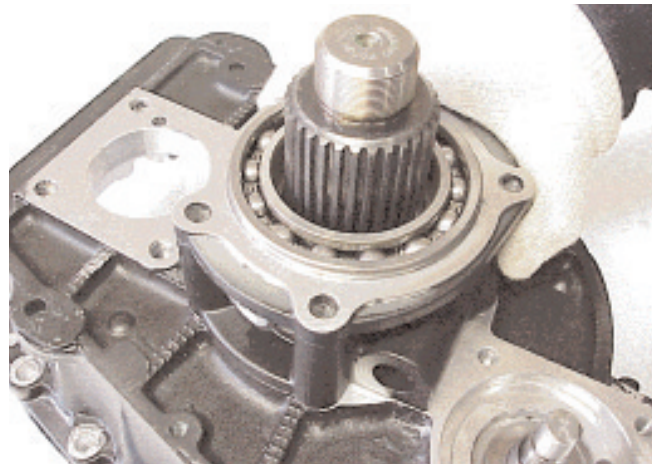

26. Apply sealant to the face of the case. Place the bearing and housing assembly over the shaft and against the case.



24. Install the output shaft bearing in the housing using a soft faced mallet and a suitable tool.



27. Apply sealant to the face of the bearing housing and install the oil seal and carrier assembly.

Main Transmission Overhaul

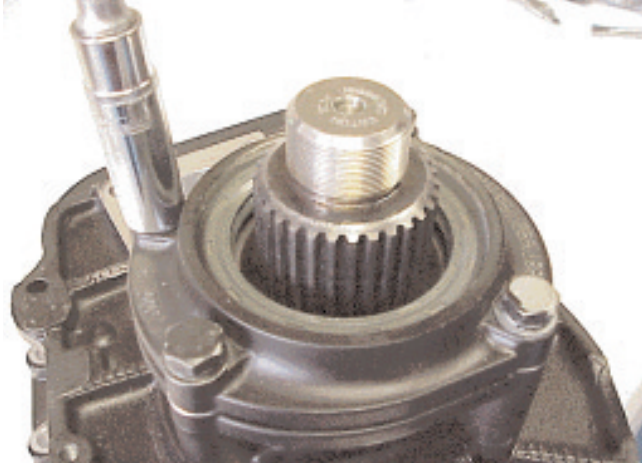

28. Apply sealant to the four capscrews and tighten to the correct torque.



31. Apply a coating of Loctite 5900 to the face of the cylinder cover. Fit the cylinder cover.



29. Change the 'O' rings in the piston if necessary. Apply silicon lubricant to the 'O' rings and fit the piston, flat face uppermost. Fit the nut.

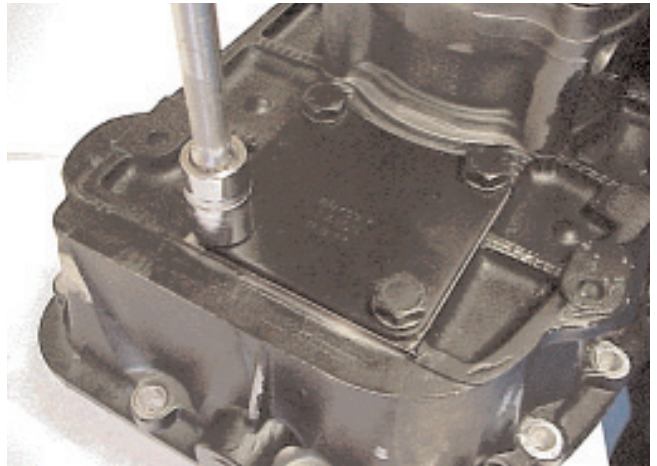

32. Apply a coating of loctite sealant and fit the rear PTO cover.



30. Change the 'O' ring if necessary. Apply silicone lubricant to the 'O' ring and to the bore of the cylinder cover.



33. Apply a smear of grease to the inner periphery of the oil seal and install the output drive flange. Temporarily place a spacer against the flange and fit the nut. Tighten firmly.
Note: Flange boss fits inside bearing track.

Main Transmission Overhaul

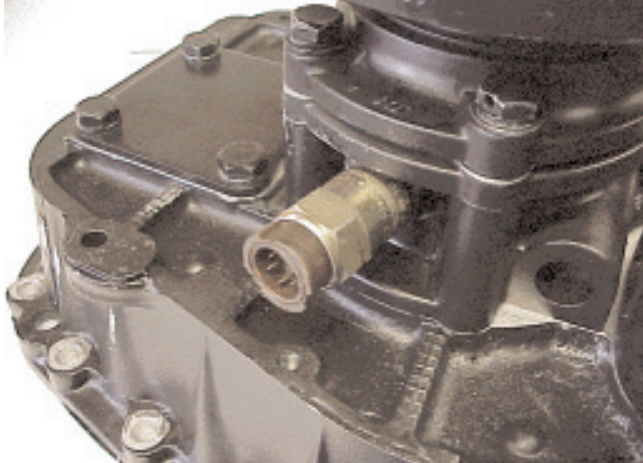

34. Fit the tachograph sender assembly or tachograph pinion and adaptor assembly as required.

Input shaft - Exploded view

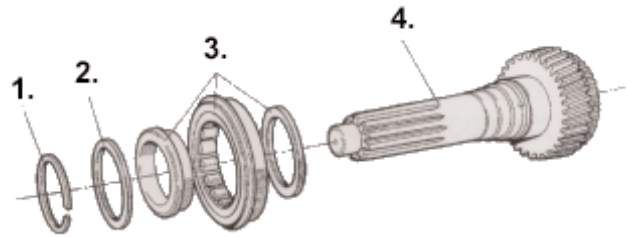

Input shaft assembly

1. Circlip 65 mm diameter
2. Spacer
3. Bearing
4. Input shaft

Disassembly



1. Support the input shaft and remove the snap ring. Remove the selective fit spacer.

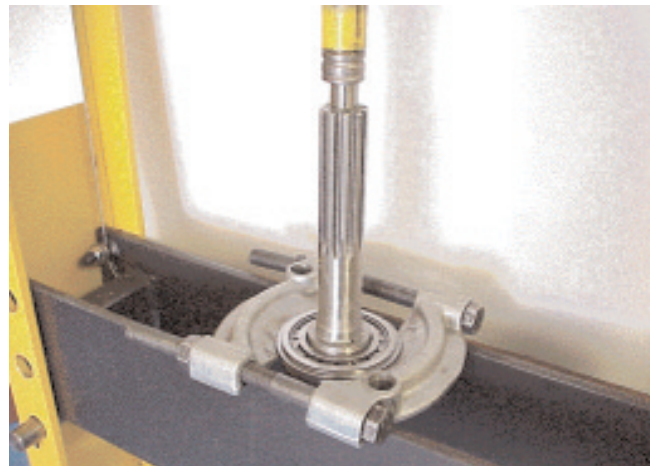

2. Support the bearing on a press or using a suitable puller press the shaft through the bearing track. Remove the bearing thrust ring. On horizontal specifications, a spacer is fitted behind the bearing.

Main Transmission Overhaul

Reassembly

Note: Heat the bearing assembly thoroughly to approximately 85°C before assembly. This greatly eases assembly and in most cases the bearing track will fit over the shaft without the need to drift it in place.



1. Fit the bearing thrust washer, grooved side uppermost. Note: - On horizontal transmissions refit the spacer before fitting the bearing thrust washer.



2. Support the heated bearing assembly, inner track downwards, on a suitable tube and install the input shaft through the bearing.



3. Use the press, or a soft faced mallet to ensure the bearing is firmly against the gear.



4. Place the original spacer against the bearing and check that the snap ring fits into its groove without free play. Check at several places around the diameter of the shaft. If there is too much free play, or the snap ring does not fit into the groove, a new thicker or thinner spacer respectively is required in place of the original.

Graded spacers are available in various sizes ranging from 3,10mm to 3,95mm in increments of 0,05mm.

Part number	Thickness (mm)
8877692	3,10
8877693	3,15
8877694	3,20
8877695	3,25
8877696	3,30
8877697	3,35
8877698	3,40
8877699	3,45
8877700	3,50
8877565	3,60
8877564	3,65
8872484	3,70
8872485	3,75
8872486	3,80
8872487	3,85
8872488	3,90
8872489	3,95

Main Transmission Overhaul



5. When the correct thickness spacer has been selected and fitted, fit the new snap ring.

Layshaft - Exploded view

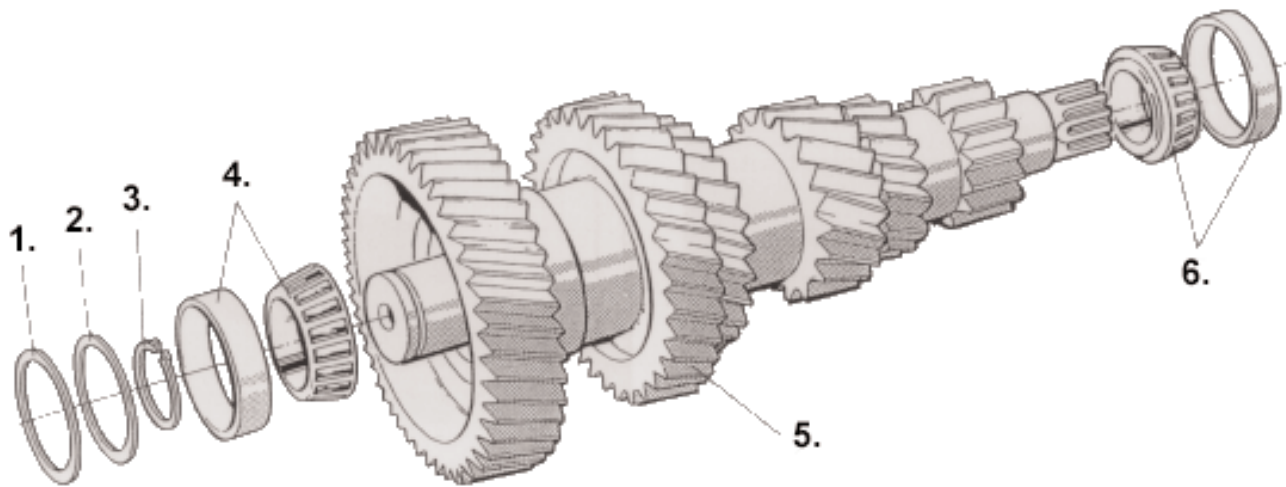

Layshaft assembly

1. Spacer 2.5/2.3 mm
2. Shim
3. Circlip
4. Taper roller bearing
5. countershaft assembly
6. Taper roller bearing

Main Transmission Overhaul Disassembly

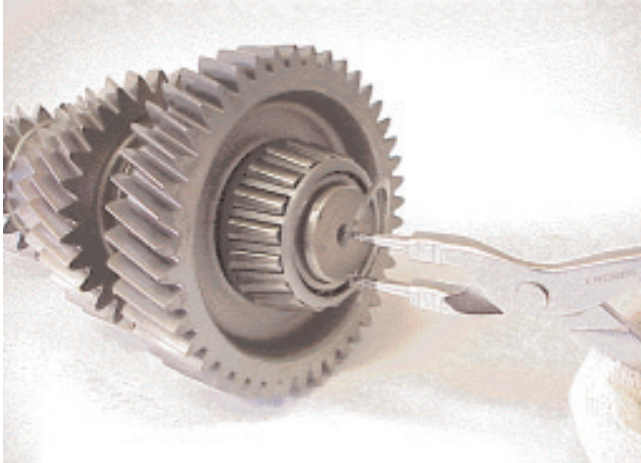

1. Support the shaft assembly and remove the graded circlip retaining the front taper roller bearing.

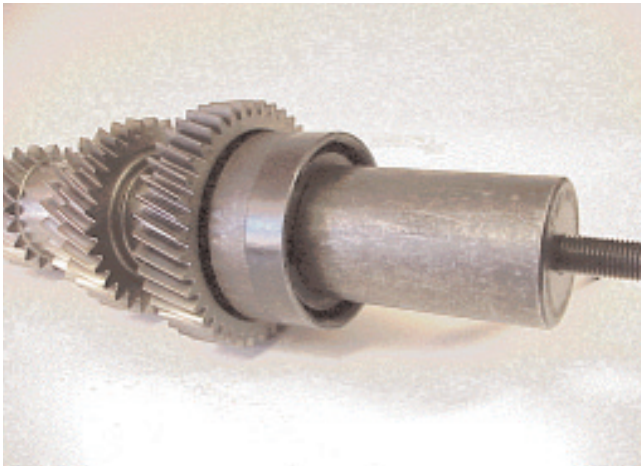

2. Use tools LC 105A and E 105-4. Remove the bearing cone and roller assembly

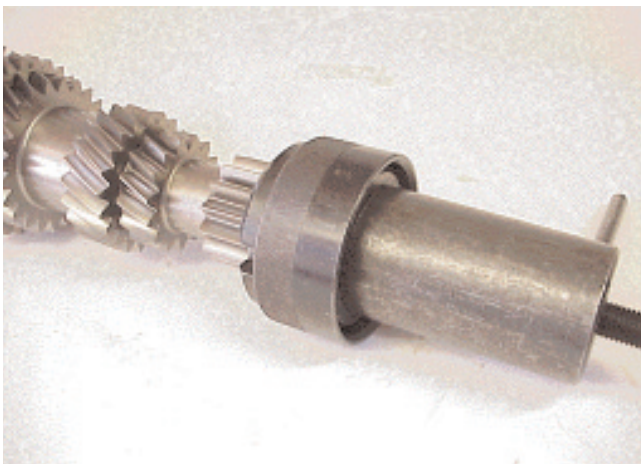

3. Support the shaft and remove the rear bearing cone and taper roller bearing assembly using the same puller and adaptor

Reassembly

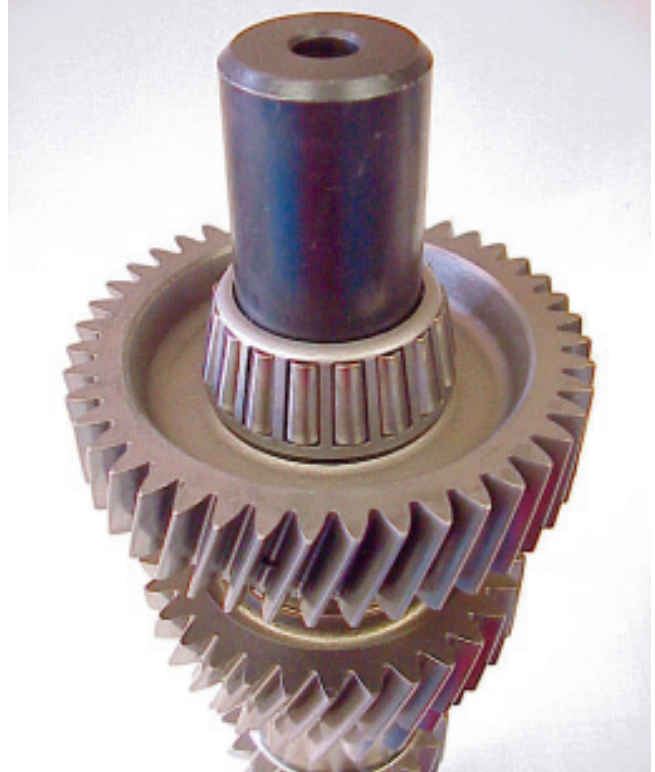

1. Heat the layshaft taper roller bearing inner races to 85°C. Support the shaft assembly forward end uppermost and place the heated inner cone and roller assembly onto the shaft. Use a suitable mandrel to make sure bearing is fully home.



2. From the range of graded fit circlips, select the circlip which fits into the groove with the minimum free play.

Main Transmission Overhaul

Circlips are available in the following sizes and Part Numbers.

Part Number	Thickness (mm)
X8870370	2.12
X8870371	2.07
X8870372	2.02
X8871536	1.97
X8871537	1.92
X8871538	1.87
X8871539	1.82
X8871540	1.77



3. Fit the circlip using circlip pliers.



4. Invert the layshaft assembly and fit the heated rear taper roller bearing inner race onto the shaft. Make sure the bearing is fully home using a suitable mandrel.

Main Transmission Overhaul

Mainshaft - Exploded view

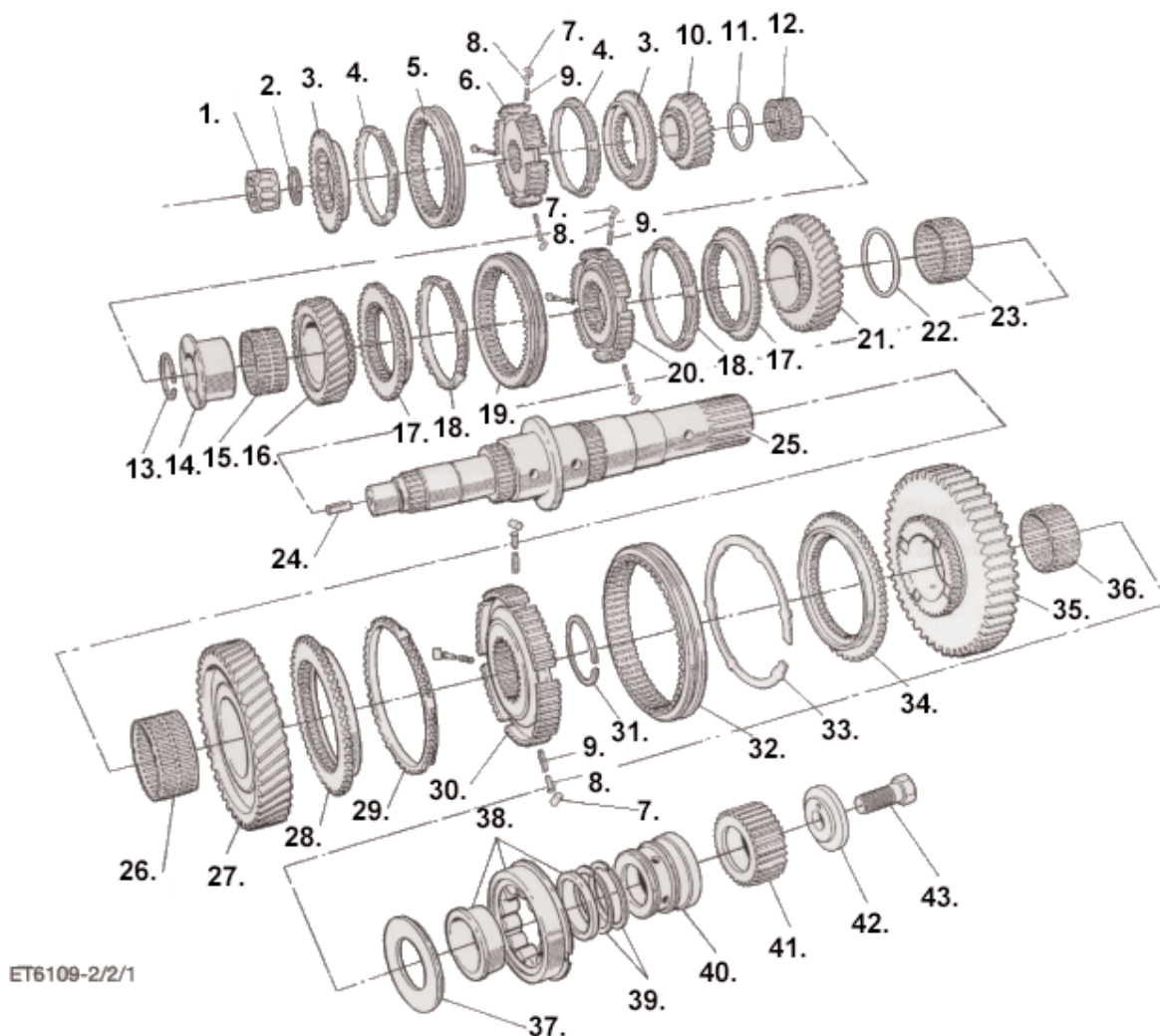

- | | | |
|---------------------------------------|-----------------------------|---------------------------------------|
| 1. Needle roller bearing | 16. Mainshaft gear, 2nd | 31. Circlip 60 dia x 2.00/2.05/2.10mm |
| 2. Circlip 40 dia. x2.02/2.07/2.12 mm | 17. Synchro flange 1st/2nd | 32. Sliding sleeve, low/rev |
| 3. Synchro flange 3rd/4th | 18. Synchro ring | 33. Circlip |
| 4. Synchro ring | 19. Sliding sleeve 1st/2nd | 34. Synchro flange, reverse |
| 5. Sliding sleeve 3rd/4th | 20. Fixed hub 1st/2nd | 35. Mainshaft gear, reverse |
| 6. Fixed hub 3rd/4th | 21. Mainshaft gear, 1st | 36. Needle roller bearing |
| 7. Synchro roller | 22. Spacer | 37. Thrust washer |
| 8. Synchro plunger | 23. Needle roller bearing | 38. Output bearing |
| 9. Compression spring | 24. Spirol pin | 39. Sealing ring |
| 10. Mainshaft gear (3rd or overdrive) | 25. Mainshaft | 40. Oil muff |
| 11. Spacer | 26. Needle roller bearing | 41. Sun gear |
| 12. Needle roller bearing | 27. Mainshaft gear, low | 42. Sun gear retainer |
| 13. Circlip 46 dia x 2.00 mm | 28. Synchro flange, low/rev | 43. Screw M16 x 45 |
| 14. Bearingsleeve, 2nd gear | 29. Synchro ring | |
| 15. Needle roller bearing | 30. Fixed hub, low/rev | |

Main Transmission Overhaul

Note: All snap rings and the circlip on the shaft are graded for selective fit. Take care not to score the bearing surfaces of the mainshaft when removing the snap rings.

Note: End float of the gears on the shaft is established in manufacture by machining the components to fine tolerances. Before disassembly of the mainshaft the end floats should be checked to ascertain whether they are within the recommended limits.

Where end float is found to be excessive it is necessary to check the gears, mainshaft, synchroniser hubs and bearing sleeve for wear. See '**Inspection of expendable parts**' and renew where necessary.

Retain the synchroniser rings and flanges in their respective pairs for assembly in the same relative positions.

End float check

End float may be checked with the shaft assembled by using a dial gauge as shown.

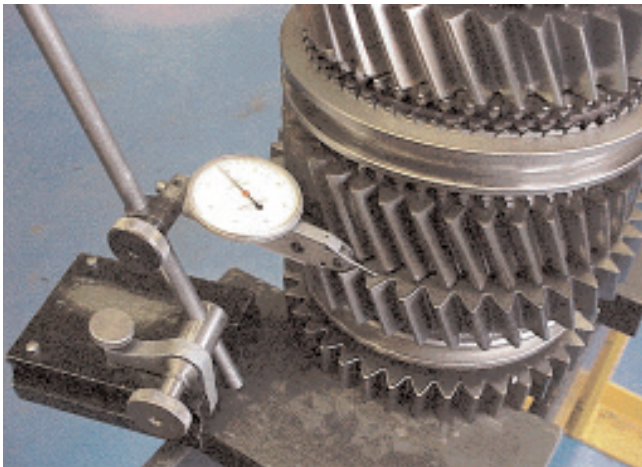

1. Mount the mainshaft assembly vertically on a suitable stand. Locate the dial gauge on the gear, zero the gauge. Raise the gear by hand and record the reading.

Disassembly



1. Support the mainshaft. Remove the hollow dowel pin from the mainshaft if necessary and remove the synchroniser ring and flange. Slide the 3rd/4th gear synchroniser sleeve upward until the three rollers are clear of the groove in the sleeve. Remove the rollers, the sleeve the plungers and the springs from the synchroniser hub.

Note: On some transmissions a restrictor is fitted to the dowel pin.



2. Remove the 3rd/4th gear synchroniser hub retaining circlip.

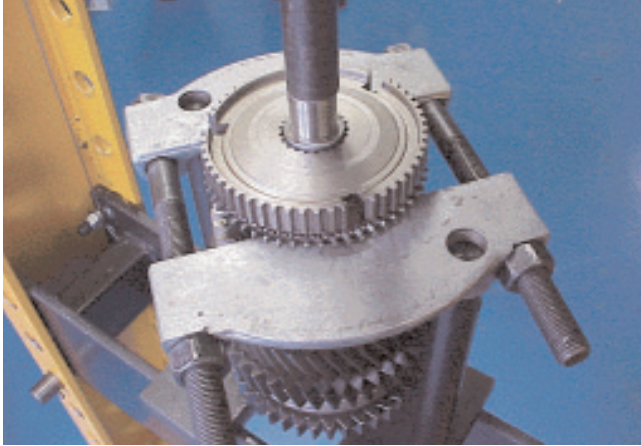

3. Assemble the puller plates over the 3rd/4th gear synchroniser hub and the 3rd gear synchroniser ring and press off the hub, cone and ring, taking care not to damage the synchro ring teeth.



6. Remove the reverse gear needle roller bearing. Lift off the reverse gear flange from the synchroniser hub. Note: There is no synchroniser ring for the reverse gear.



4. Lift off the third gear and 3rd gear needle roller bearing and spacer ring. Note the position of the spacer ring for reassembly.

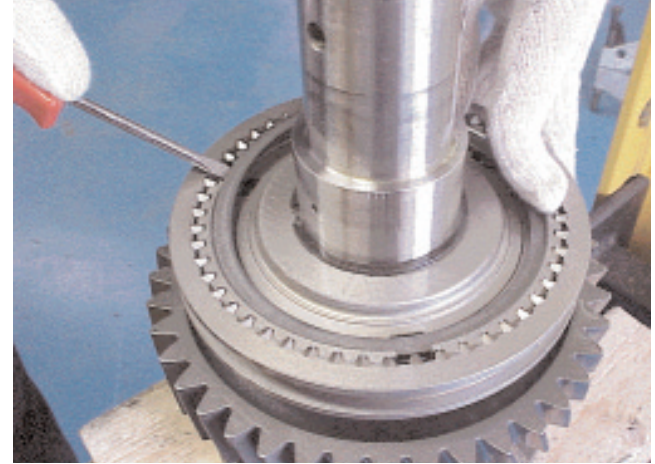

7. Remove the large internal snap ring from inside the reverse/low synchroniser hub.



5. Invert the mainshaft assembly in the press and using suitable puller plates, under the reverse gear, remove the reverse gear and integrated bearing/thrust washer. Note: Some transmissions may be fitted with a bearing track and separate thrust washer.



8. Slide the reverse/low gear synchroniser sleeve carefully rearwards until the three rollers are clear of the groove in the sleeve. Remove the rollers, the sleeve and the three plungers and springs from the synchroniser hub.

Main Transmission Overhaul

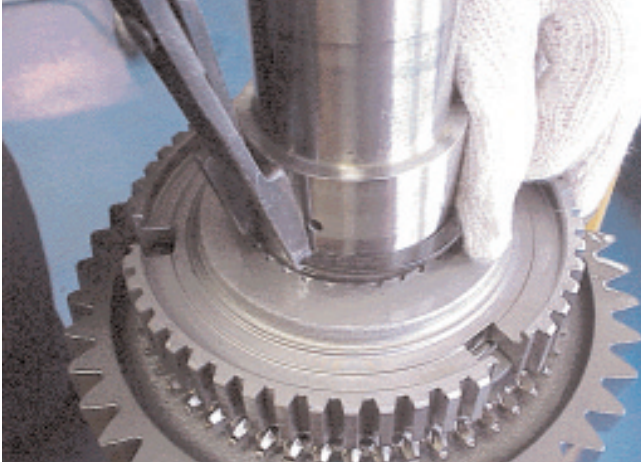

9. Remove the reverse/low synchroniser hub retaining snap ring.



11. Remove the low gear needle roller bearing. Separate the low gear synchroniser hub, flange, ring and gear.

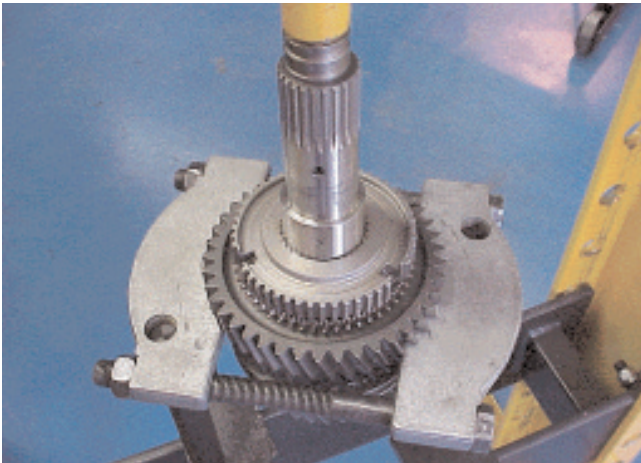

10. Assemble puller plates under the low gear and support on the press.

Note: It is imperative that low gear is supported and that the remainder of the gears and shaft do not foul the press bed or supporting blocks when the shaft is being pressed through. Press the shaft through low gear and the low/reverse synchroniser hub.

On specifications with non-synchromesh crawler, there is a second snap ring on the other side of the hub. This snap ring should be left in place.



12. Invert the shaft and remove the 2nd gear bearing sleeve retaining snap ring.

Main Transmission Overhaul

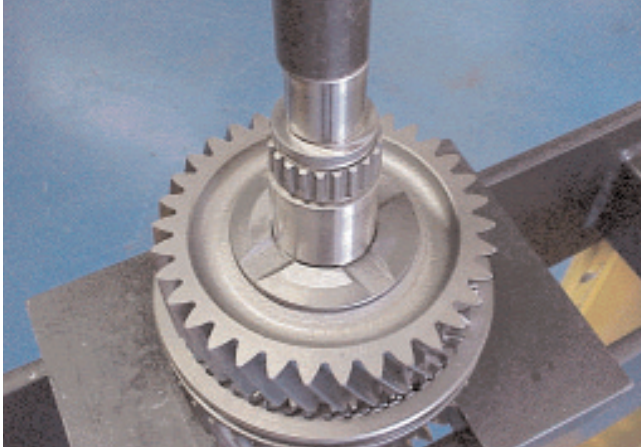

13. Support the shaft on the press under 1st gear.
Note: It is imperative that 1st gear is supported and that the flange on the shaft does not foul the supporting blocks or press bed when the shaft is being pressed through. Do not allow the shaft to drop through and become damaged or scored.

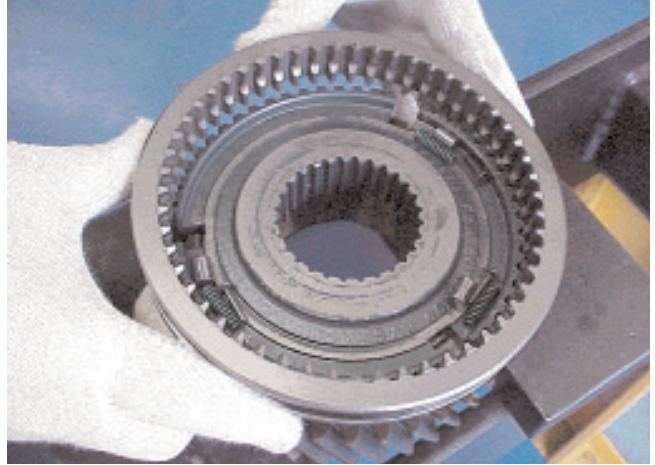

16. Remove the synchroniser sleeve, synchroniser rollers, plungers and springs.



14. Place the 1st/2nd gear assembly on a bench - 2nd gear uppermost. Remove the bearing sleeve and needle roller bearing.

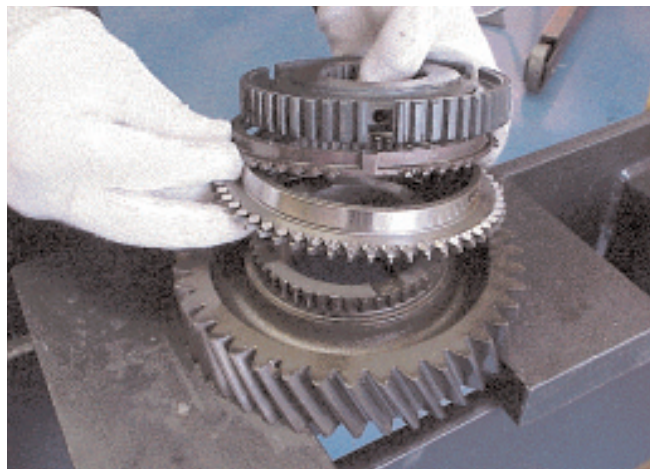

17. Remove the synchroniser hub. Remove the synchroniser flange and synchroniser ring from the 1st speed gear.



15. Remove 2nd speed gear, synchroniser flange and synchroniser ring.



18. Remove the 1st gear needle roller bearing and bearing spacer ring.

Main Transmission Overhaul

Reassembly

Note: The following parts must be heated to the temperatures recommended prior to assembly. Place the parts on a hotplate or in a temperature controlled oven for not less than 30 minutes to make sure they are thoroughly heated before placing them in position. Once fitted and cooled the parts will shrink to an interference fit.

- Synchroniser hubs (3 off))
- 2nd gear bearing sleeve) 85°C
- Mainshaft rear bearing inner track)

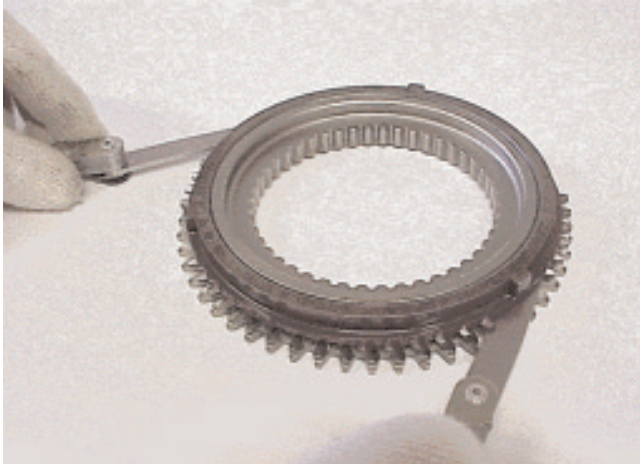

1. Before assembling the synchroniser assemblies on the mainshaft, check the fit of each synchroniser ring to its flange. Place the synchroniser ring onto its mating flange and while holding the two parts firmly together, measure the clearance between the two rings using feeler gauges at several points around the circumference as shown. Renew both parts if the measurement is not within the specified limits.

Note: The reverse gear is fitted with a flange which engages with the sliding sleeve and which is similar in appearance to a synchroniser flange. The conical face however is not machine finished and no synchroniser ring is fitted to the assembly for reverse gear.



2. Support the mainshaft rear end uppermost. Fit the low gear bearing.

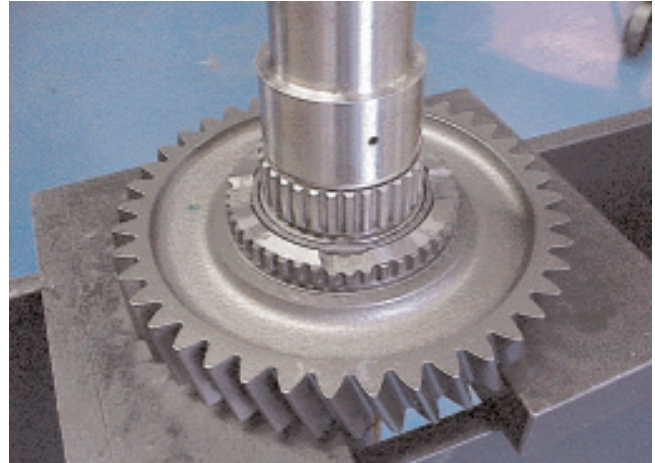

3. Lubricate the bearing with clean gear oil and fit the low gear over the bearing.

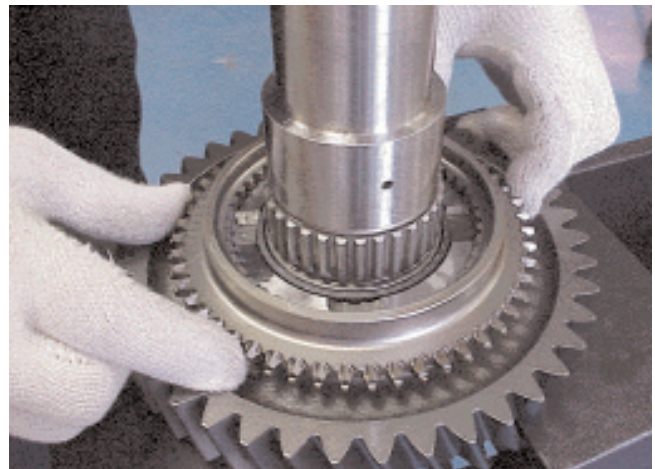

4. Fit the low gear synchroniser flange to the gear. If a synchroniser ring is fitted this must be lubricated with transmission oil prior to fitment.

Main Transmission Overhaul

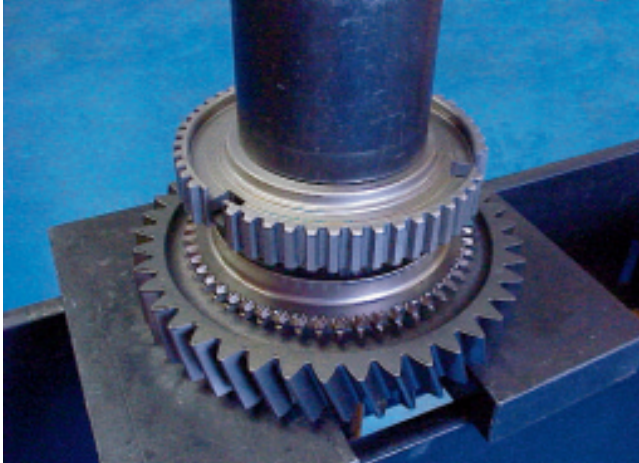

5. Synchronised crawler : Take the heated reverse/low synchroniser hub, with the internal snap ring groove uppermost, and place it over the splines of the mainshaft. Ensuring that the shoulders on the synchroniser ring align with the slots on the synchroniser hub press it fully home.

Non Synchronised crawler : Fit the snap ring to one of the internal grooves of the synchroniser hub. Take the heated synchroniser hub, second snap ring groove uppermost, and fit it to the splines on the mainshaft. Press the synchroniser hub fully home.



6. From the range of graded snap rings select the thickest one which fits into the groove with the minimum free play.



7. Install the snap ring in the groove taking care not to damage the mainshaft bearing surfaces.



8. Check that the gear end float is within the tolerances stated in the chart.

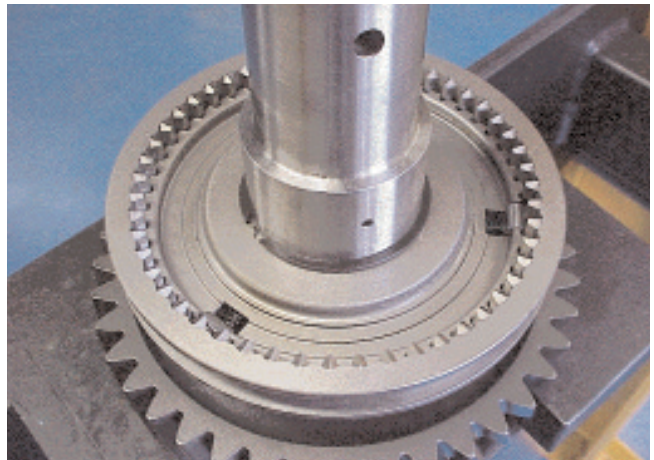

9. Assemble the three springs and plungers into the synchroniser hub. Place the synchroniser sleeve over the hub, pointed teeth downwards, and support it with the internal annular groove just above the hub. Position the three rollers as shown, resting on the heads of the plungers, and press downward on the sleeve.

Main Transmission Overhaul

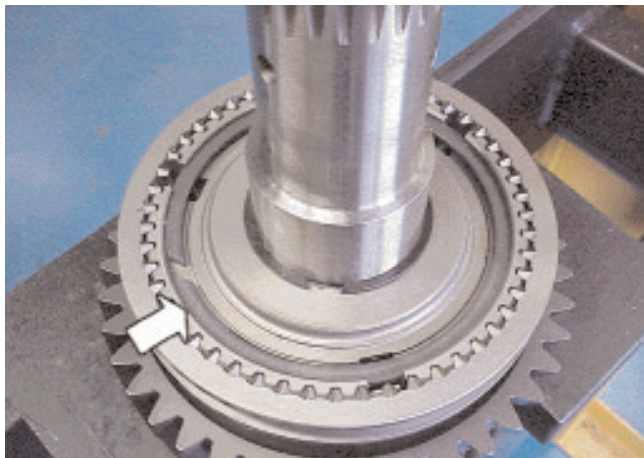

10. Install the special snap ring into the synchroniser hub ensuring the tongues are properly located in the slots in the hub.



11. Install the reverse gear flange into the synchroniser hub.

Note: No synchroniser ring is fitted to reverse gear.



12. Lubricate reverse gear bearing and install the bearing and reverse gear onto the shaft and into the reverse gear flange.

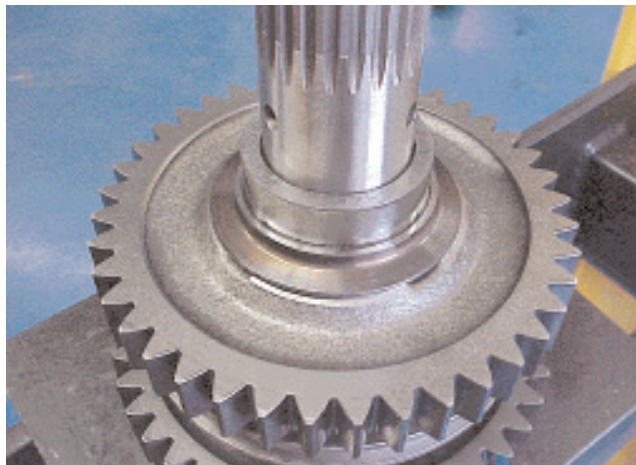

13. Take the heated mainshaft bearing and fit it, flange face downwards, on to the mainshaft.

Note: Some transmissions are fitted with a thrust washer which is not integral to the bearing. In this instance the thrust washer, chamfered side uppermost, should be fitted against the gear.

Take the heated mainshaft rear bearing inner track and fit it over the shaft, flange against the thrust washer. Use a soft drift or flanged driver to ensure bearing is fully home against the washer.

Note: When cooled, the bearing track should be sufficiently tight on the shaft to retain the reverse gear on the shaft.

Note: Tool E 114 may be fitted at this stage as a precaution only to retain the bearing on the shaft. It must not be used to retain a loose bearing on the shaft. If the bearing is loose, the cause must be investigated and a new bearing and/or shaft fitted.



14. Invert the shaft in the vice, lubricate and install the 1st gear bearing and 1st gear.

Main Transmission Overhaul



15. Install the bearing spacer ring into the gear and against the bearing.

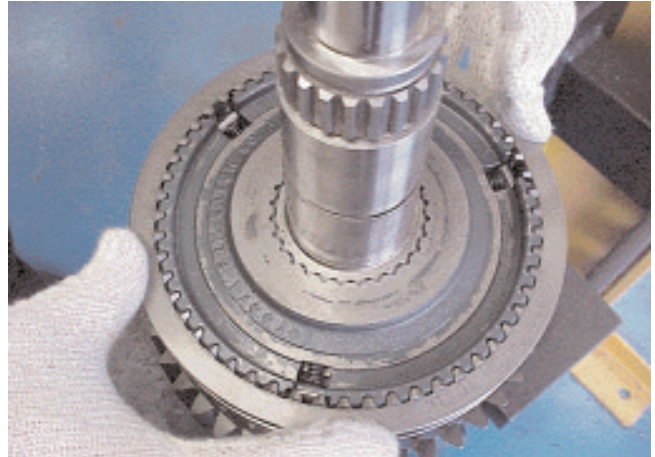

18. Assemble the three springs and plungers into the hub and install the 1st/2nd gear synchroniser sleeve and rollers as described in sub-operation 9.



16. Install the 1st gear synchroniser flange to the gear. Lubricate and fit the synchroniser ring.



19. Lubricate the synchroniser ring with transmission oil. Place the 2nd gear synchroniser ring, ensuring that the shoulders of the synchroniser ring engage the slots of the synchroniser hub, onto the assembly. Place the synchroniser flange onto the assembly.



17. Support the mainshaft on the press. Place the heated 1st/2nd synchroniser hub over the splines on the shaft. Align the slots with the shoulders on the synchroniser ring and press the hub fully home. Check that the gear end float is within the tolerances stated in the chart.

Main Transmission Overhaul



20. Lubricate the 2nd gear and bearing and position the gear into the synchroniser ring and the bearing into the gear.
Note: A smear of petroleum jelly applied to the outer edge of the bearing will support the bearing to stand proud of the gear and ease the alignment of the bearing sleeve in the next operation.

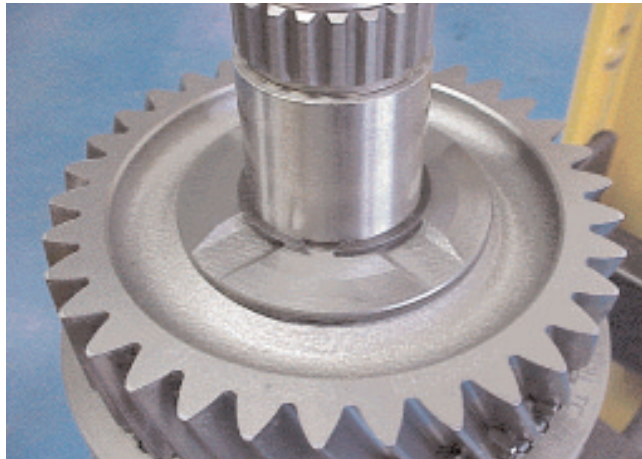

23. Fit the snap ring into the groove taking care not to damage the mainshaft bearing surface.



21. Take the heated 2nd gear bearing sleeve and locate it inside the bearing and over the shaft. Use the press to ensure the sleeve is firmly home against the synchroniser hub.



24. Check that the gear end float is within the tolerances stated in the chart.



22. From the range of graded snap rings select thickest one which fits into the groove with the minimum free play.



25. Lubricate the 3rd gear bearing and install the bearing and 3rd gear onto the shaft.

Main Transmission Overhaul

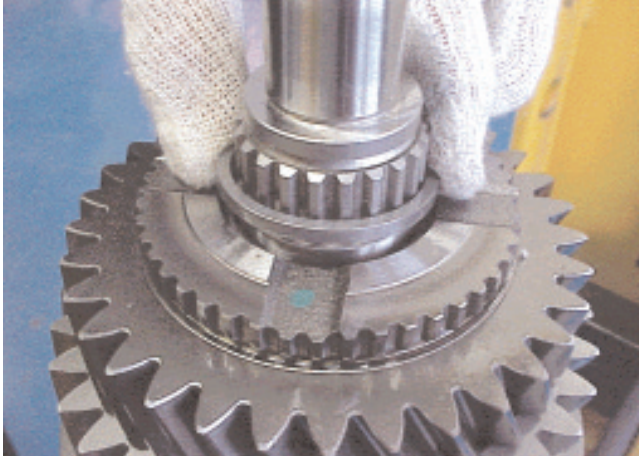

26. Place the 3rd gear bearing spacer ring into the gear against the bearing.

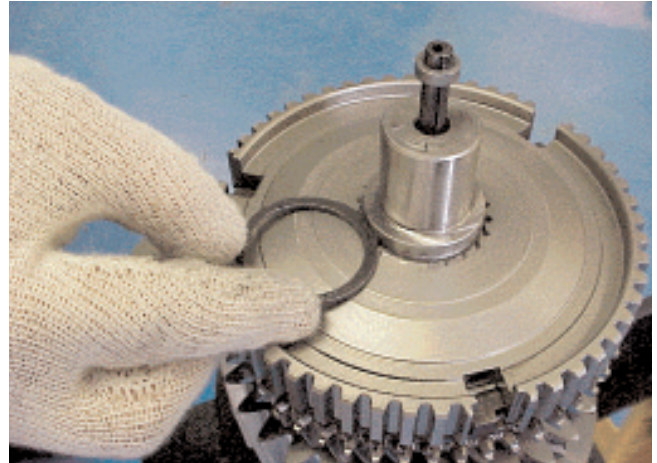

29. From the range of graded circlips select the thickest one which fits into the groove with the minimum free play.



27. Lubricate the synchroniser ring with transmission oil. Fit the 3rd gear synchroniser flange and synchroniser ring.

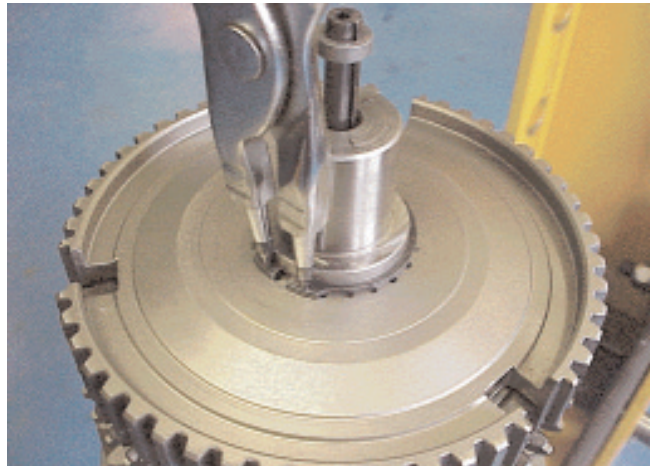

30. Fit the circlip into the mainshaft.

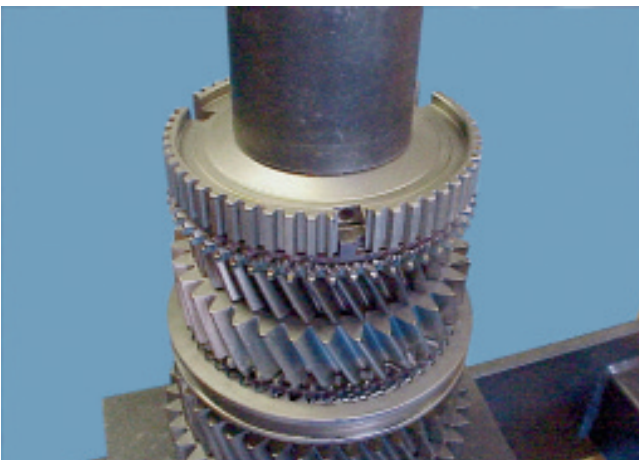

28. Take the heated 3rd/4th synchroniser hub and place it, boss side downwards on the shaft. Ensure that the slots in the hub align with the shoulders on the synchroniser ring. Press the hub fully home and hold under pressure for 3 to 5 minutes.



31. Check the gear end float using feeler gauges.

Main Transmission Overhaul



32. Assemble the three springs and plungers into the hub and install the synchroniser sleeve and rollers as described in sub-operation 9.

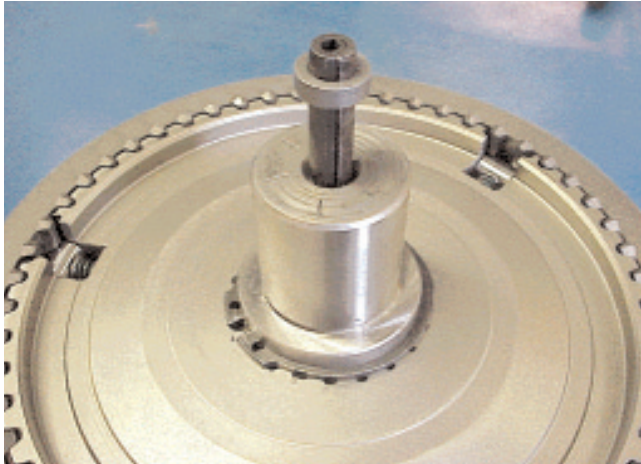

33. If removed fit a new roll pin and, if applicable, restrictor.

Main Transmission Overhaul

Selector shaft - Single H - Exploded view

Selector shaft assembly (vertically mounted unit) - Single H

1. Rotation pin
2. Shift pad
3. Overdrive fork
4. Overdrive selector
5. Selector key
6. Selector shaft
7. Interlock key
8. Selector fork 3rd/4th
9. Pin
10. Locating screw
11. Selector block
12. Selector fork 1st/2nd
13. Selector fork, low/rev

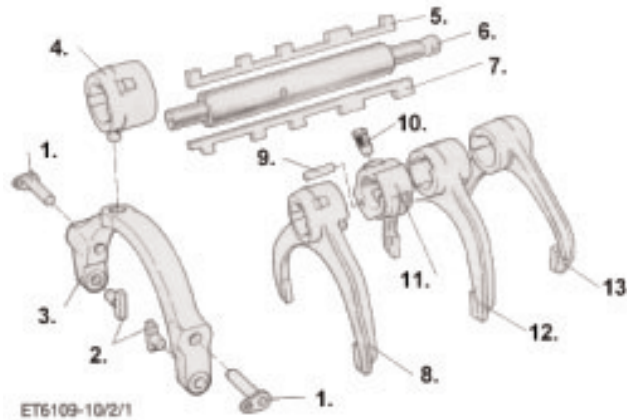

Disassembly

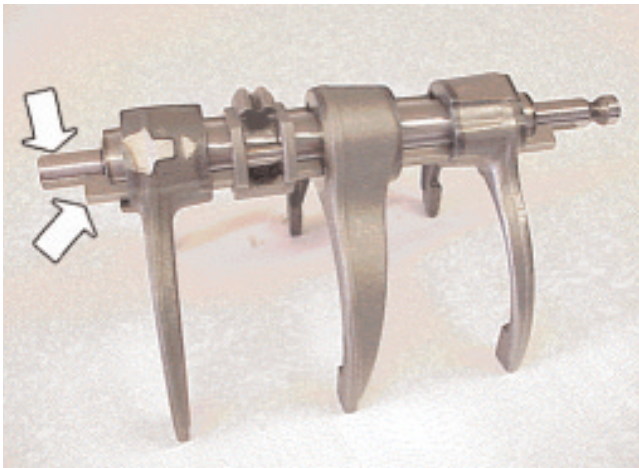

1. Place selector assembly on bench with selector block to the left. Mark the front of the shaft and keys to aid reassembly.

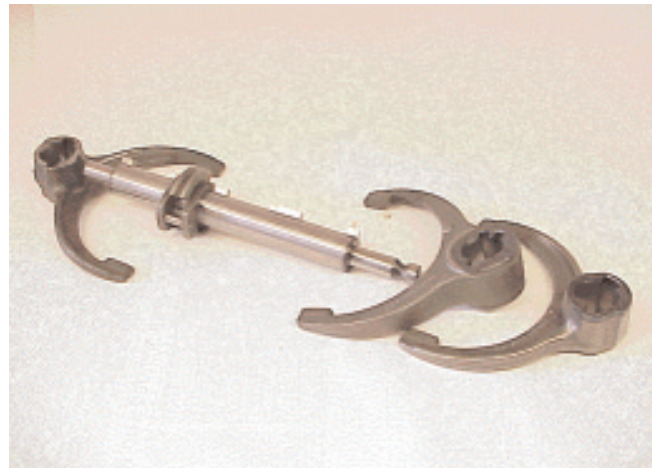

3. Remove the selector forks from the shaft.

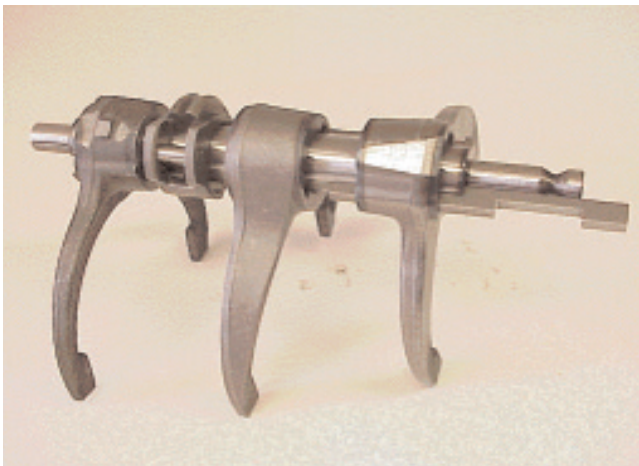

2. Hold the assembly by the selector block and withdraw the interlock key from the rear.



4. Remove the capscrew from the selector block. Slide the selector block and selector key off the selector shaft.

Main Transmission Overhaul Reassembly

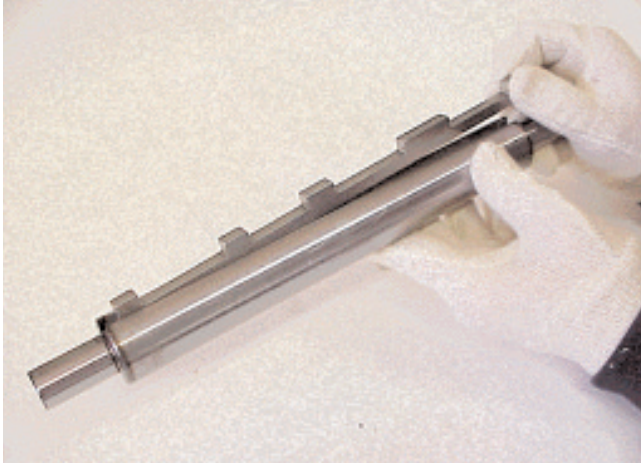

1. Place selector key into slot on the selector shaft with the three small lugs to the front.



4. Rotate the forks until the slots line up with the groove on the selector shaft for the interlock key. Fit the interlock key from the rear.

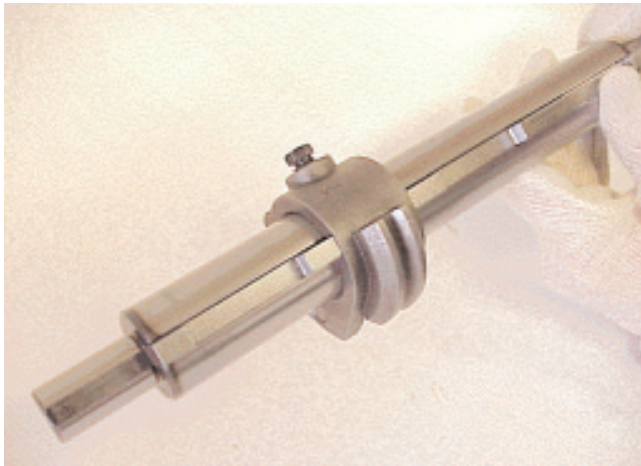

2. Put the selector block onto the shaft and tighten the cap screw.

Note: If reusing the screw apply Loctite 270 to the threads before fitting.

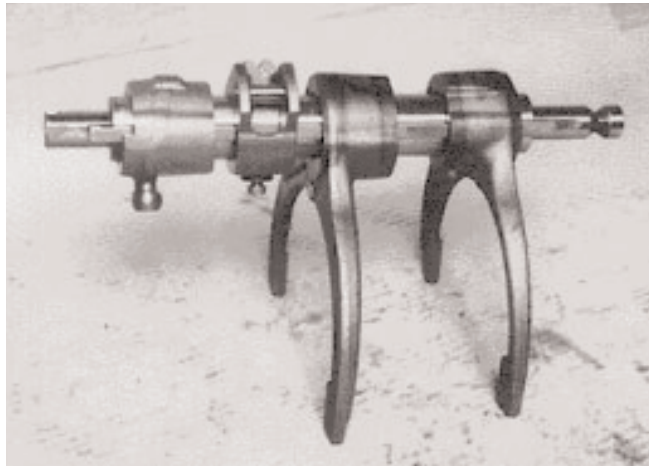

5. On overdrive units the 3rd/4th fork is replaced by a selector. Check the fit of the selector before assembling the transmission.



3. Place the forks in their respective positions on the selector shaft.

Main Transmission Overhaul

Selector shaft - Double H - Exploded view

Selector shaft assembly (vertically mounted unit) - Double H

1. Pin
2. Tapered capscrew
3. Selector block
4. Selector fork 3rd/4th
5. Selector fork 1st/2nd
6. Selector fork low/rev
7. Selector key
8. Interlock key
9. Selector shaft

Overdrive assembly is similar to single H overdrive assembly

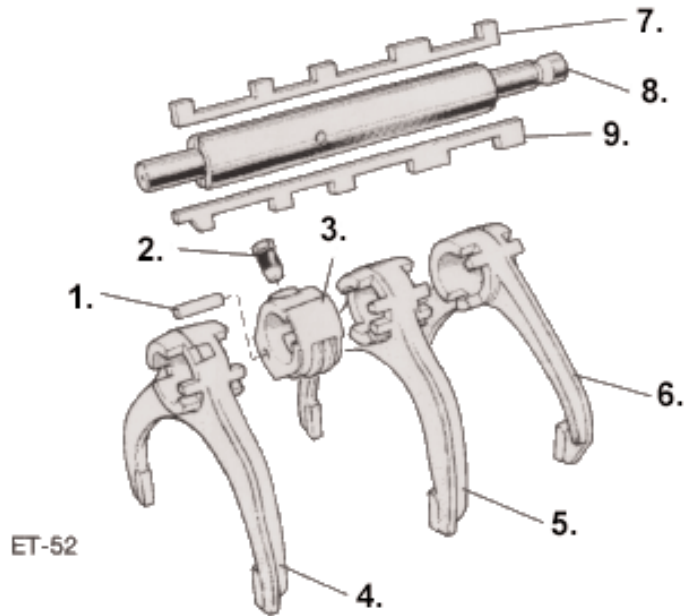

Disassembly

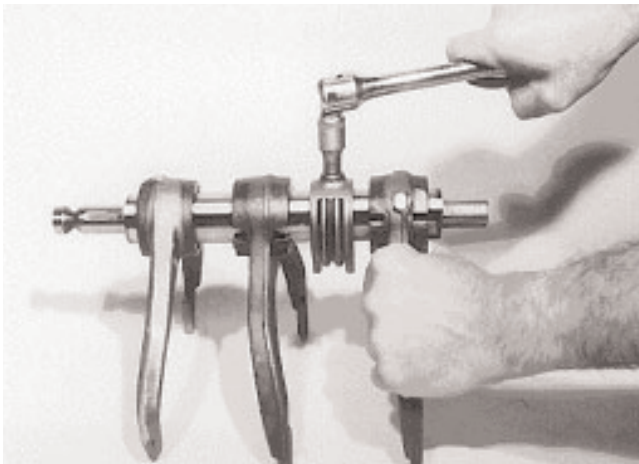

1. On double H transmissions, remove the tapered capscrew from the selector block.

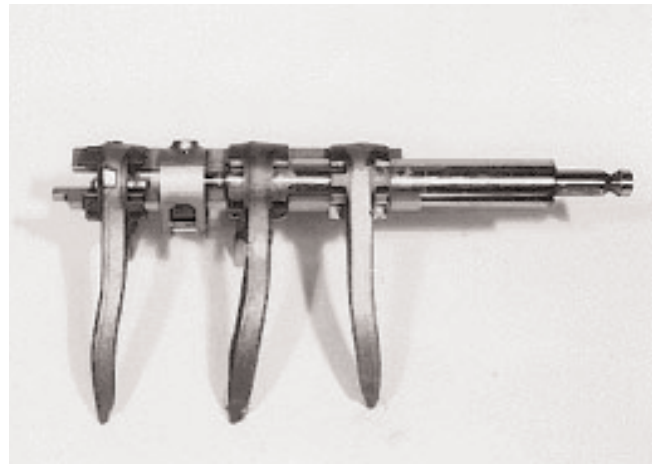

2. On double H transmissions hold the selector block and 1st/2nd fork and withdraw the selector shaft towards the right.

Main Transmission Overhaul

Selector shaft - Double H - Exploded view

Selector shaft assembly (vertically mounted unit) - Double H

1. Pin
2. Tapered capscrew
3. Selector block
4. Selector fork 3rd/4th
5. Selector fork 1st/2nd
6. Selector fork low/rev
7. Selector key
8. Interlock key
9. Selector shaft

Overdrive assembly is similar to single H overdrive assembly

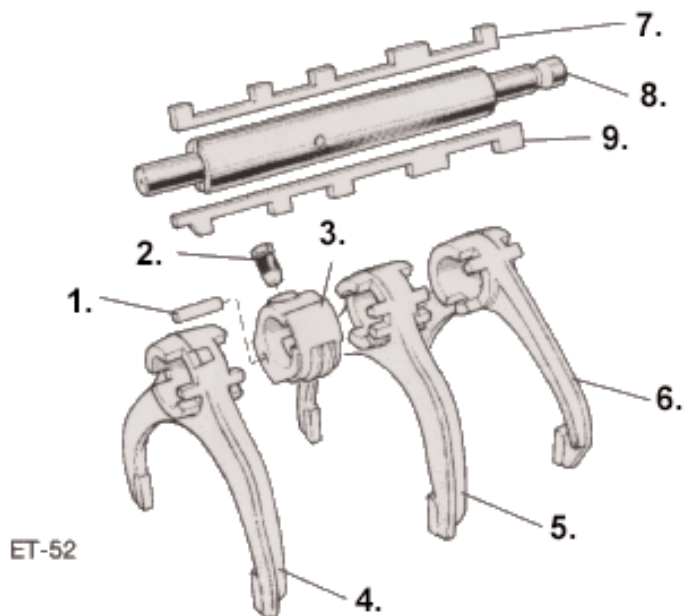

Reassembly



1. Hold the selector key, forward end to the left and place the 1st/2nd selector fork, crank to the left into the third slot in the key.



2. Place the selector block, pin uppermost and threaded hole facing (vertically mounted unit), into the second slot in the key.

Note: Horizontal Units: Place the selector block, with the groove uppermost and the thread hole facing, into the second slot in the key.

Main Transmission Overhaul



3. Place the 3rd/4th selector fork, crank to the left, into the first slot in the key. On overdrive transmissions, place the overdrive selector, ball pin end to the left, into the first slot in the selector key.



6. Still holding the key and forks insert the shaft, smaller segment between the slots facing towards you, first over the interlock key, then under the selector key and through the bosses of the forks.



4. Place the low/reverse selector fork, crank to the right, into the last slot in the key.

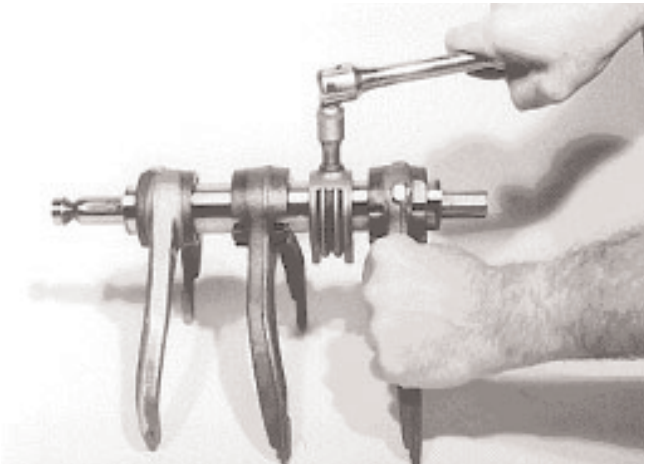

7. Pass the shaft through the forks, and align the hole in the selector block with the hole in the shaft. Fit a new tapered capscrew and tighten to the correct torque. If a new screw is not available apply Loctite 270 to the screw threads before fitting.



5. Support the key and forks and pass the interlock key, forward end to the left, into position in the forks.

Main Transmission Overhaul

Transmission case - Reassembly

Note: Before reassembling the transmission case ensure that each section case and covers are clean and that all gaskets and jointing/sealing materials are cleaned from the mating faces. When reusing patch lock bolts or fitting capscrews to through holes apply the recommended threadlock or sealant to the threads.

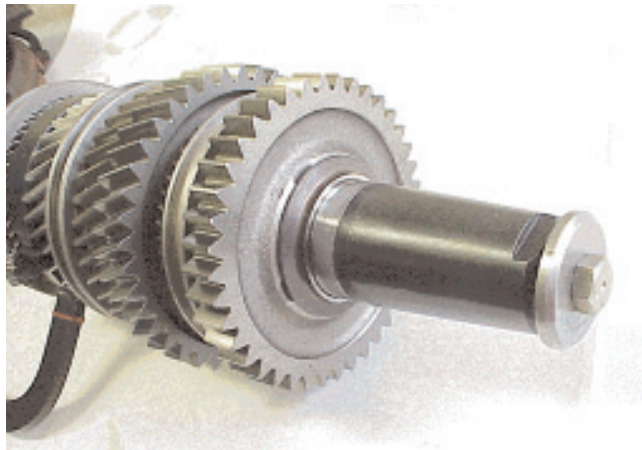

3. Fit tool E 114 over the rear end of the mainshaft. Retain in place with a large washer and the sun gear retaining bolt or suitable equivalent.

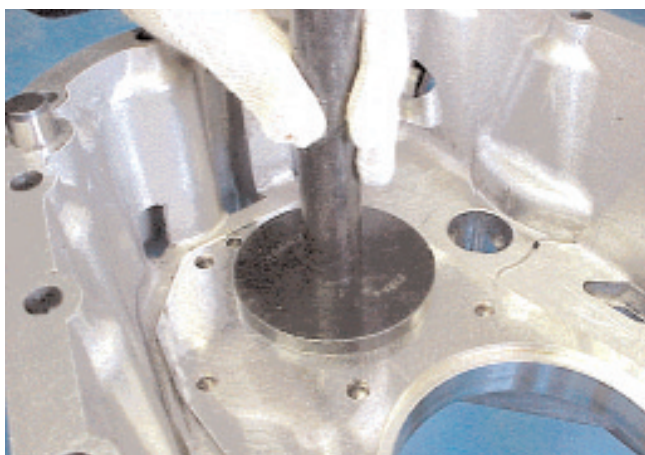

1. Support the intermediate case on the stand, rear face uppermost. Using the tool E 109-6 install the layshaft rear bearing cup into the case. Drive in until almost flush with the rear face of the bearing bore.

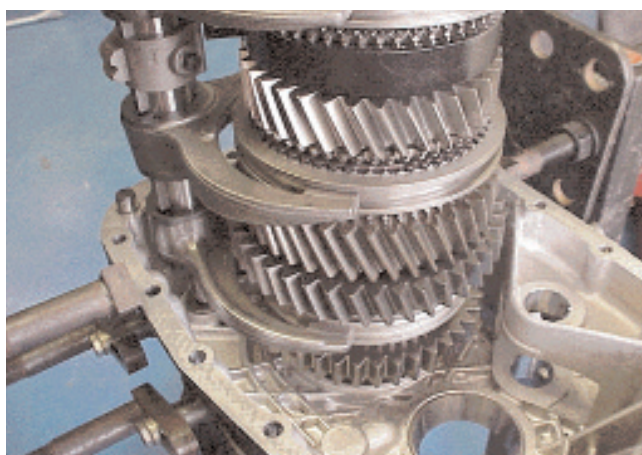

4. Locate the selector shaft assembly to the mainshaft. Using tools E 116A and E 116-1 and a hoist, lower the assembly into the case making sure the selector shaft enters the rear bush. Support the mainshaft and selectors approximately 20 mm above the normal installed position.

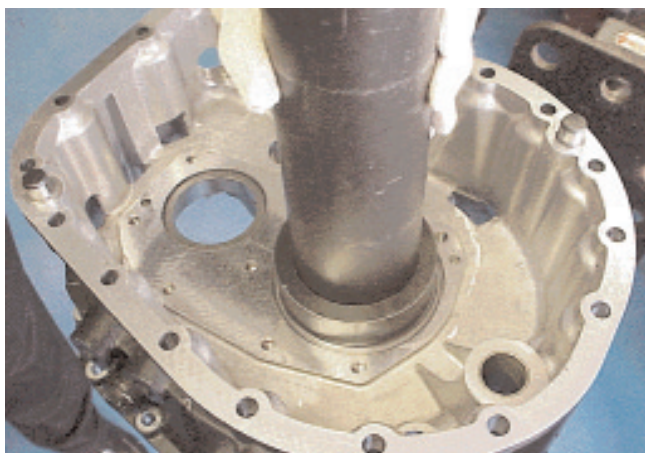

2. Install the mainshaft rear bearing outer track and roller assembly snap ring groove outermost into the case using a suitable mandrel. Invert the case on the stand.

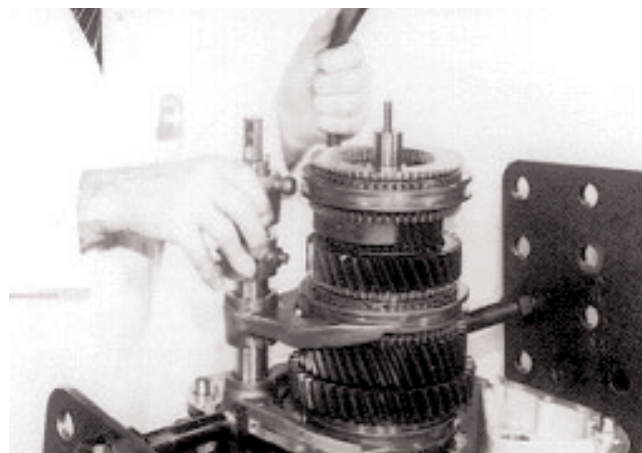

5. On overdrive transmissions locate the selector shaft assembly to the mainshaft without the 3rd/4th overdrive selector fork. This can be assembled later and avoids the risk of the fork pads dropping into the transmission.

Main Transmission Overhaul

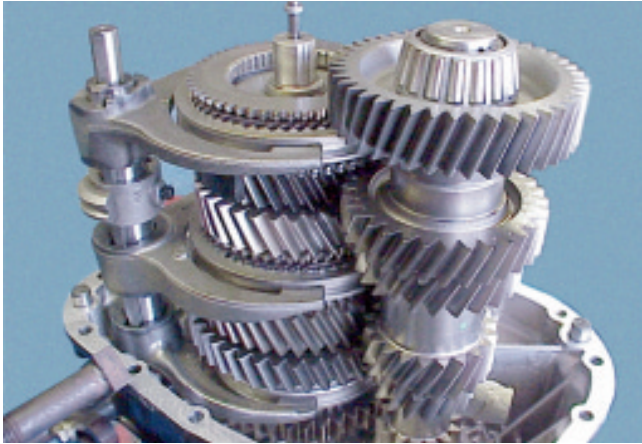

6. Lubricate the synchroniser ring with transmission oil. Fit the 4th gear (3rd gear overdrive), synchroniser ring and synchroniser flange to the synchroniser hub. Locate the layshaft into mesh with the mainshaft.

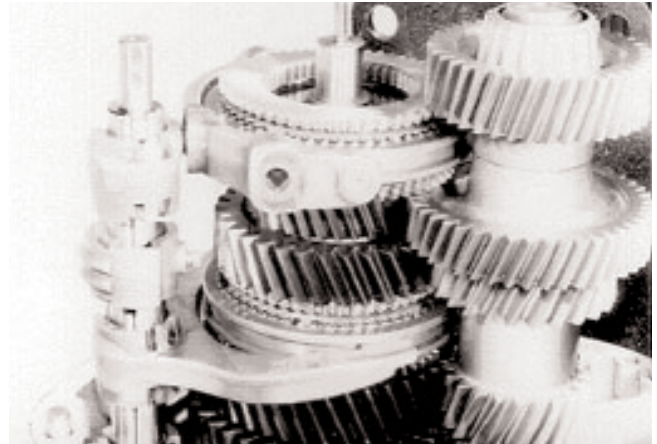

9. Manoeuvre the 3rd/4th overdrive fork into the selector ball end and rotate the selector until the centre line of the fork pivot pin holes is at approximately 90° to the centre line through the overdrive selector.



7. Lower the hoist and allow the mainshaft, layshaft and selector shaft to rest in their respective bearings and bushes. Ensure the selector block is positioned so that it will not foul the front case and remove the lifting tool.



10. Lubricate and install the spigot bearing on the mainshaft.

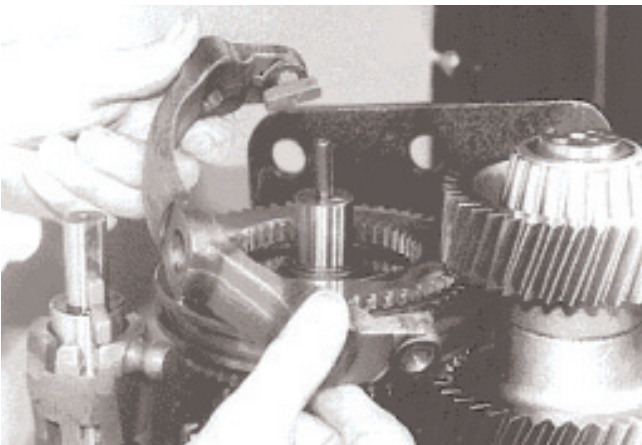

8. On overdrive transmissions, install the fork pads into the 3rd/4th overdrive selector fork. Engage the fork and pads into the synchroniser sleeve, shorter offset to the right-hand side of the transmission as illustrated.

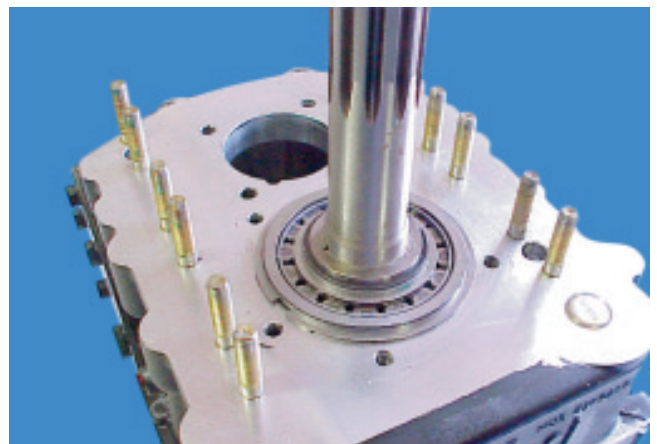

11. Install the input shaft and bearing assembly into the front case. On direct drive models tap the shaft and bearing into the case, from the front, until the bearing snap ring abuts the case. On overdrive transmissions, remove the bearing outer snap ring and install the shaft and bearing from the inside of the case outwards. Refit the snap ring. Tap the bearing back until the snap ring abuts the case.

Main Transmission Overhaul



12. Install the layshaft front bearing cup into the front case assembly using tool E 109-6.

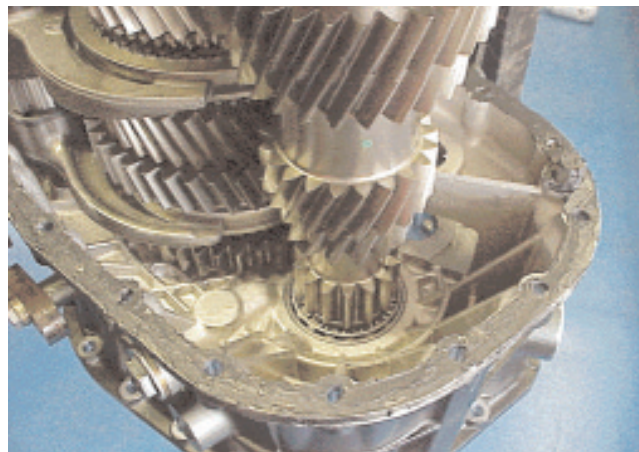

15. Apply sealer to the case mating flange ensuring that there is a continuous bead around the flange and the retaining capscrew holes.



13. If removed, install a new oil seal into the input shaft bearing front cover using the special tool. Press the seal firmly down to the shoulder ensuring the seal is not damaged.



16. Locate the front case onto the intermediate case making sure the selector shaft enters the front bush and that the locating teeth on the input gear engage with the teeth on the synchroniser flange. Rotate the input shaft slightly to ensure engagement

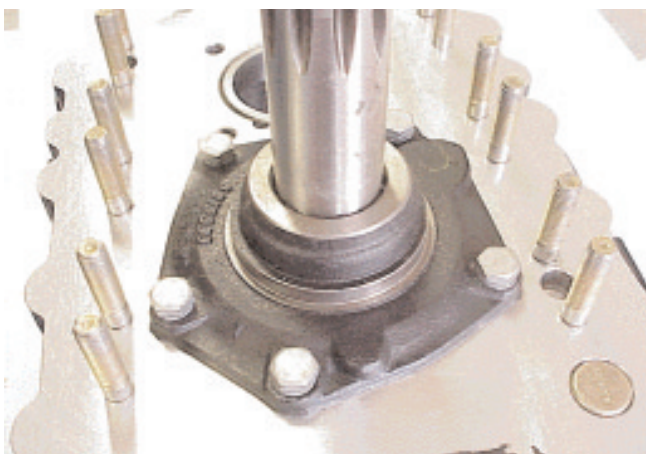

14. Lubricate the shaft seal surface and apply flange sealant to the mating face of the front cover. Install the front cover and tighten the capscrews to the correct torque.



17. Install the flange capscrews, nuts and washers and tighten to the correct torque.

Main Transmission Overhaul

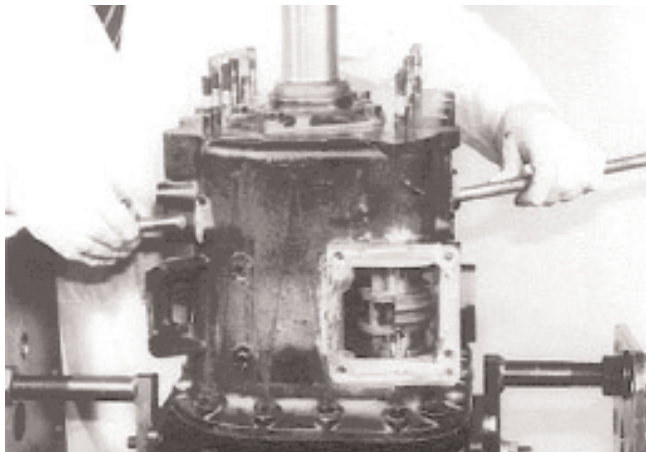

18. On overdrive transmissions, using a suitable probe as illustrated, align the overdrive selector fork pivots with the holes in the case. If necessary replace the 'O' rings which are fitted to some types of overdrive pivot pins. Apply a coating of loctite 5900 to the inside face of the pin flanges and install the pins.

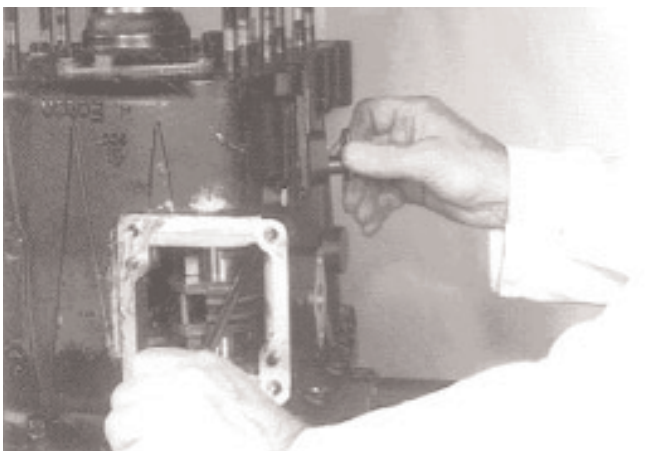

19. When aligning the right hand pin, use a screwdriver and lift the selector and fork through the remote control aperture. Tighten the capscrews to the correct torque.

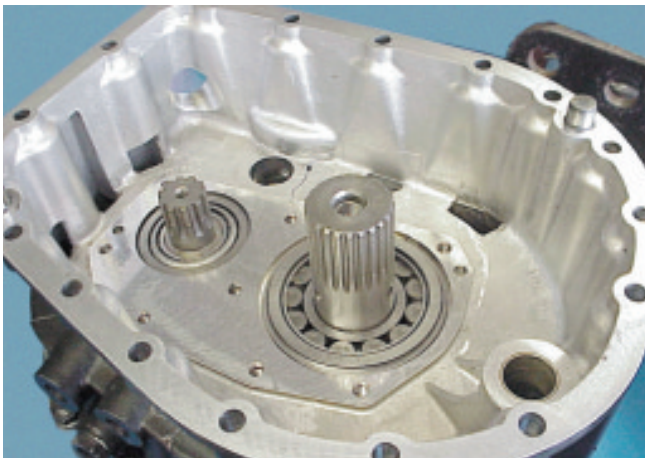

20. Invert the case and remove the tool E 114.

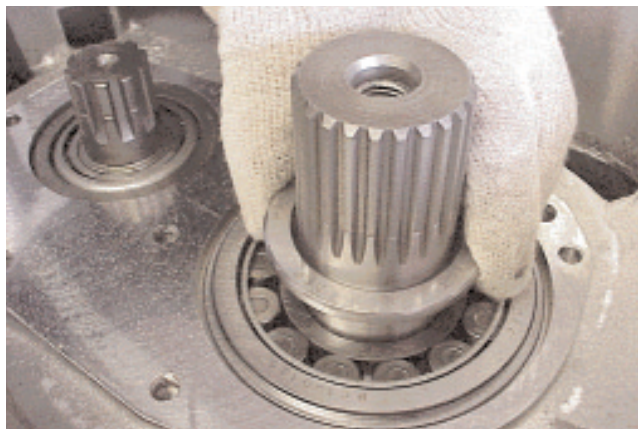

21. Install the mainshaft bearing thrust washer, oil groove towards the bearing. If a ball bearing is fitted, heat the inner race and lightly tap into position.

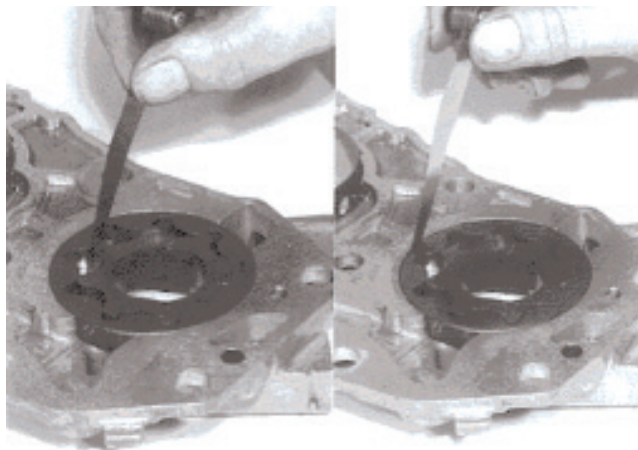

22. Remove the two screws and separate the pump halves. Check that the clearances between the rotors are within the recommended limits. Renew the pump if clearances exceed 0.50 mm.

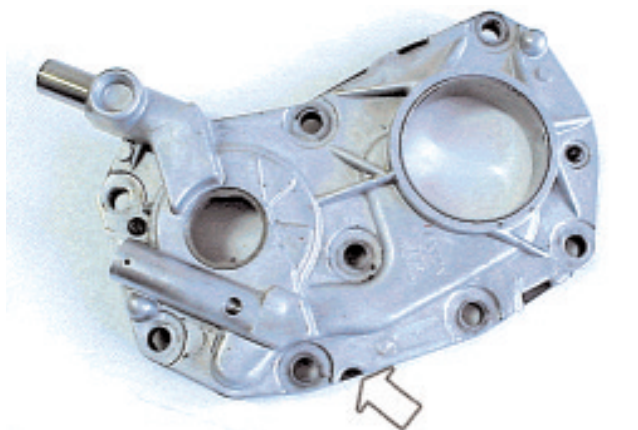

23. Ensure that the mating faces of the pump halves are clean and reassemble the pump. DO NOT use sealant. Tighten the screws securely.

Note: Pumps fitted to transmissions NOT fitted with an oil cooler facility are identified by a notch (arrowed) in the edge of the cover.

Main Transmission Overhaul

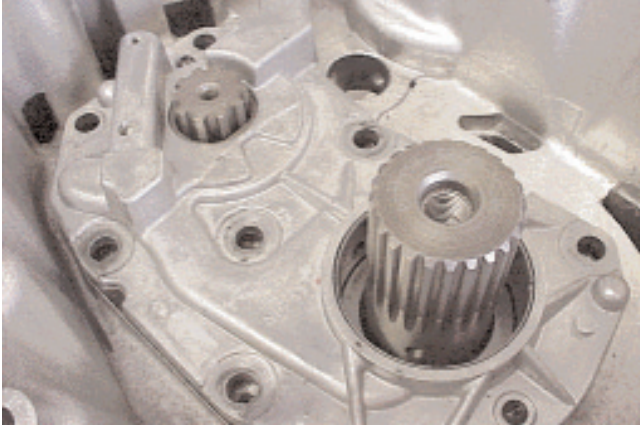

24. Fit the oil pump ensuring that the flats on the oil pump rotor engage the flats on the countershaft. Refit the oil pump strainer and bracket on multi-purpose specification transmissions. Using a new seal refit the oil strainer/drain plug.



27. Install the sun gear onto the mainshaft.



25. If removed, install the sealing rings on the oil muff collar. Check the clearance between the rings and collar as illustrated. Renew the rings if the clearance is less than the recommended tolerance (0.178 mm), or the rings are excessively worn or scored.

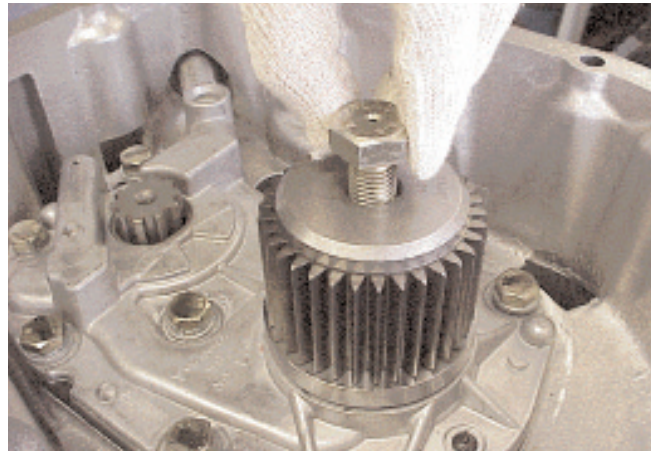

28. Locate the special retaining washer against the sun gear and fit a new patchlock retaining capscrew.



26. Lubricate the oil muff and locate it onto the rear of the mainshaft. Carefully compress the sealing rings and push the oil muff into the pump.

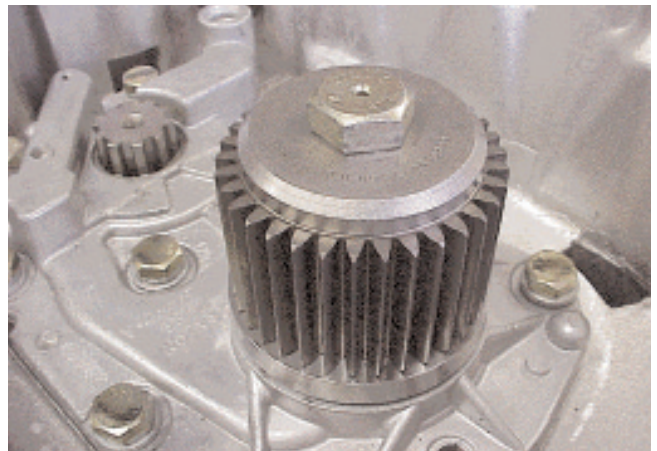

29. Using appropriate tool to restrain the sun gear, tighten the capscrew to the correct torque. Invert the transmission. Invert the transmission.

Main Transmission Overhaul

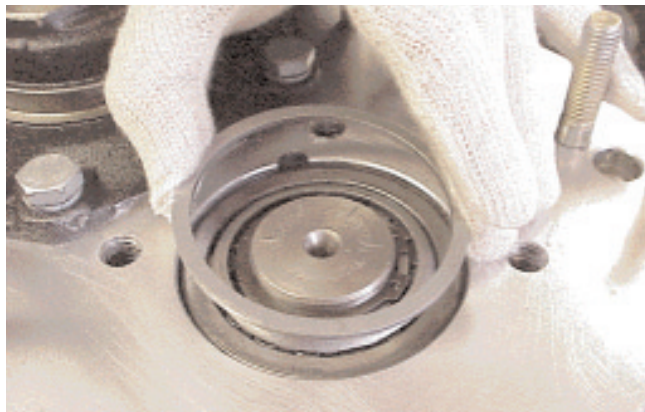

Setting the bearing preload

30. Ensuring that the layshaft bearing is fully seated select a shim(s)/spacer and place them against the layshaft bearing.

Note: The shim(s)/spacer must stand proud of the front face of the case.

Shims are available in the following sizes.

Part Number	Thickness (mm)
F88891	0.051
F88892	0.127
F88893	0.254
F88894	0.508
Spacer	
8875879	2.10

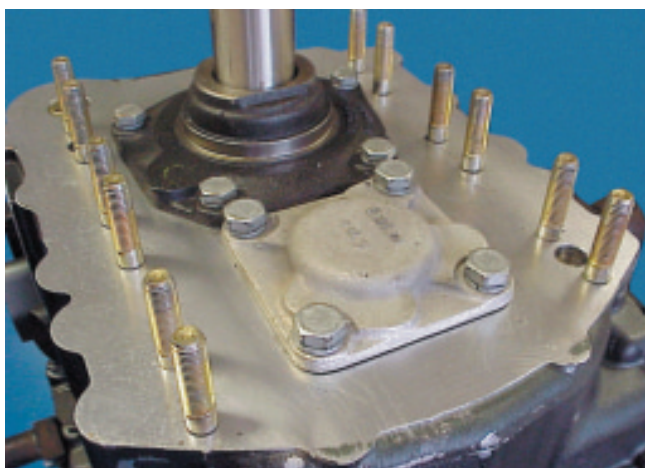

31. Install the layshaft front bearing cover (without sealant). Fit the capscrews without spring washers. Carefully and evenly tighten the capscrews while rotating the input shaft backwards and forwards to settle the bearings. Tighten the capscrews until some resistance can be felt on the input shaft.

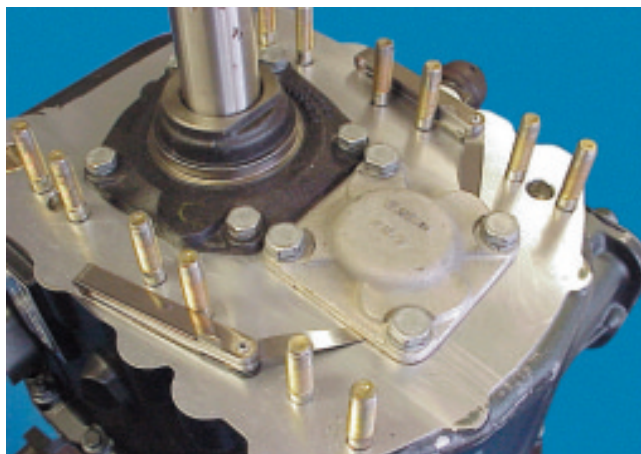

32. Back off the four capscrews to zero torque then retighten just sufficiently to nip the bearing cover plate. Using feeler gauges, measure the clearance between the cover plate and the case at several points.

From the range of graded spacers select the thickness which will give the required preload to the layshaft bearings of 0.075 to 0.125 mm with new bearings of 0.00 to 0.05 mm with used bearings.

Example

Spacer thickness	2.10 mm
add shim	+ 0.508
	= 2.608
subtract clearance	- 0.30
	= 2.308
add preload	+ 0.05
	= 2.358
subtract spacer	- 2.10
	= 0.258
Shim required	0.254 mm

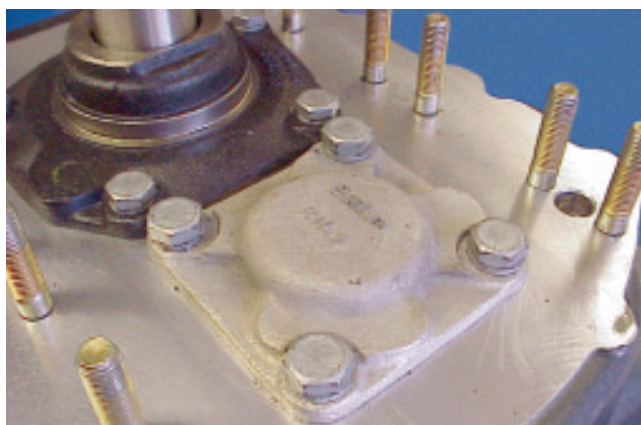

33. Lubricate the layshaft bearing, install the graded spacer of the selected thickness, apply flange sealant and install the cover plate. Apply sealant and tighten the capscrews to the correct torque

Main Transmission Overhaul

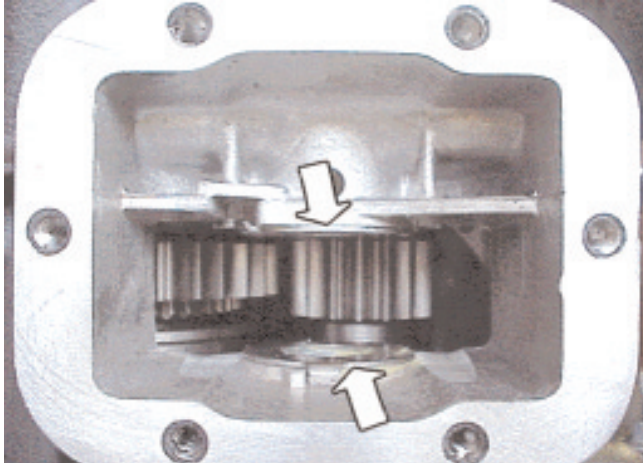

34. Invert the transmission again, rear end uppermost. Apply petroleum jelly to the reverse idler gear thrust washers and locate them into position in the transmission case.

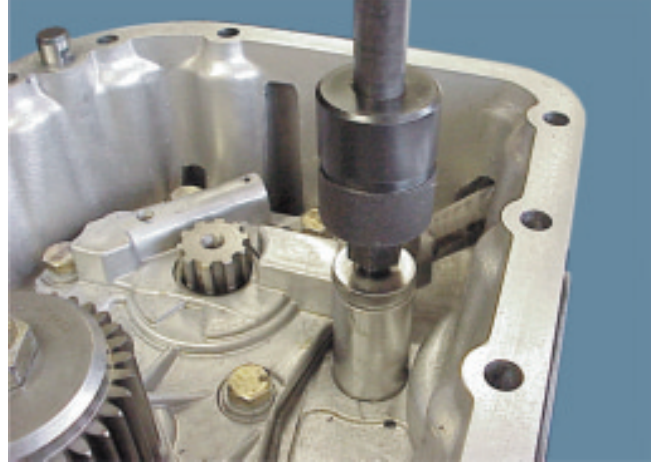

36. Two types of reverse idler shaft are utilised. The new design incorporates serrations machined onto the idler shaft to provide retention in the intermediate case, as shown above, whereas the old design has a cross drilled hole to accommodate a locating pin. Ensuring that the thrust washers and reverse idler gear are aligned fit the reverse idler shaft. Ensure that, where the reverse idler shaft is retained by a pin, the larger diameter of the hole in the reverse idler shaft is facing outwards.

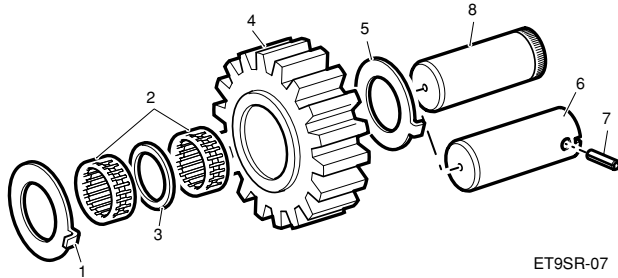

ET9SR-07

Reverse idler gear assembly

- | | |
|--------------------------|------------------------|
| 1. Thrust washer | 5. Thrust washer |
| 2. Needle roller bearing | 6. Shaft |
| 3. Spacer | 7. Parallel groove pin |
| 4. Gear, reverse idler | 8. Shaft |

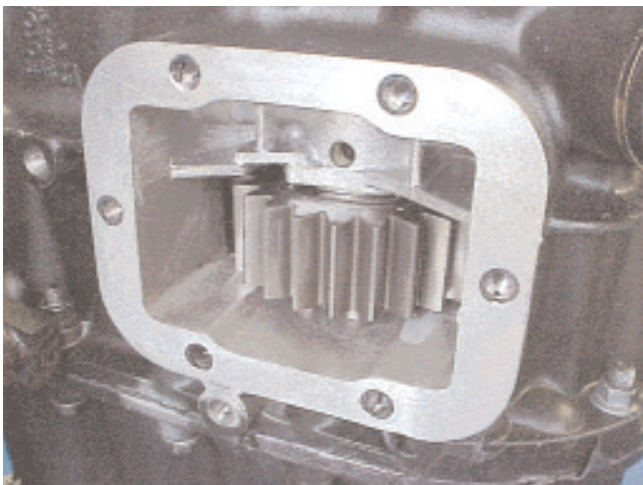

35. Install the bearings and bearing spacer into the reverse idler gear and locate the assembled gear between the thrust washers and into mesh with the layshaft and the mainshaft reverse gear.

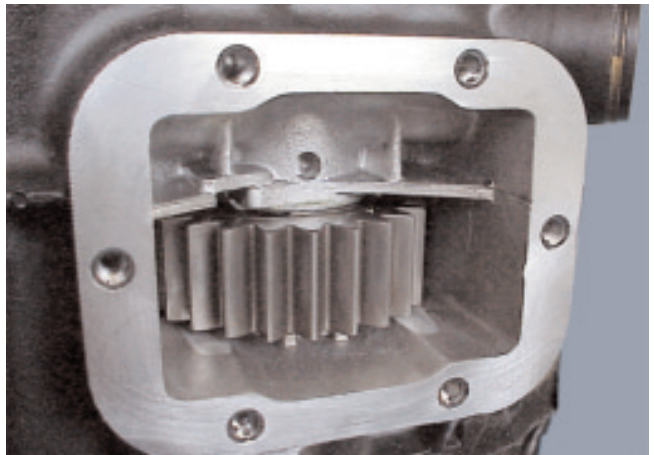

37. Take care to ensure that the components are not dislodged as the idler shaft is fitted. Serrated reverse idler shafts should be driven in until the serrations are fully engaged in the intermediate case. Cross drilled reverse idler shafts should be drifted in until the cross drilled hole aligns with the drilling in the intermediate case and then, having aligned the holes, a new pin should be driven in until flush with the intermediate case. Where fitted refit the circlip

Main Transmission Overhaul



38. Install the reverse idler gear/PTO cover plate using Loctite sealant. Tighten the capscrews to the correct torque.



39. Lubricate the selector interlock pin and install it, rounded end first, into the range indicator switch bore hole. Push it right through until it is located in the selector shaft detent groove.

Note: The interlock pin must be installed now, before the rear case assembly is fitted.



40. Apply sealant to the intermediate case rear flange ensuring there is a continuous bead around the flange and the retaining capscrew holes.

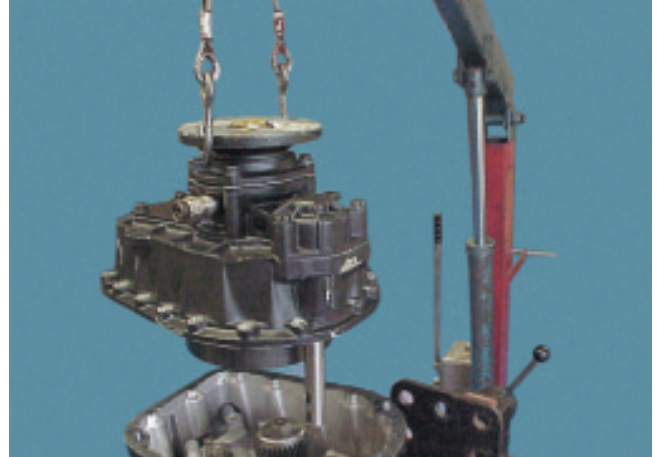

41. Support the rear case assembly on a suitable sling and hoist as illustrated ensuring that the shaft is as near vertical as possible.

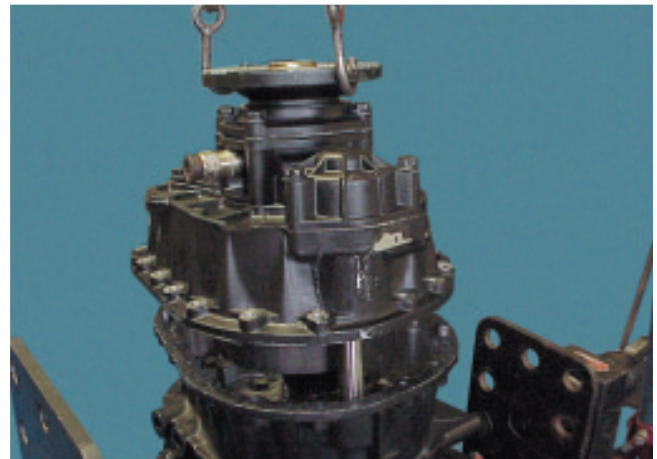

42. Lower the rear case over the intermediate case ensuring that the range change selector rod aligns with the bush in the intermediate case. Rotate the output flange slightly to aid alignment over the sun gear if necessary.



43. Refit the filter regulator assembly and range change slave valve. Install the flange capscrews, nuts and washers, tighten to the correct torque.

Main Transmission Overhaul

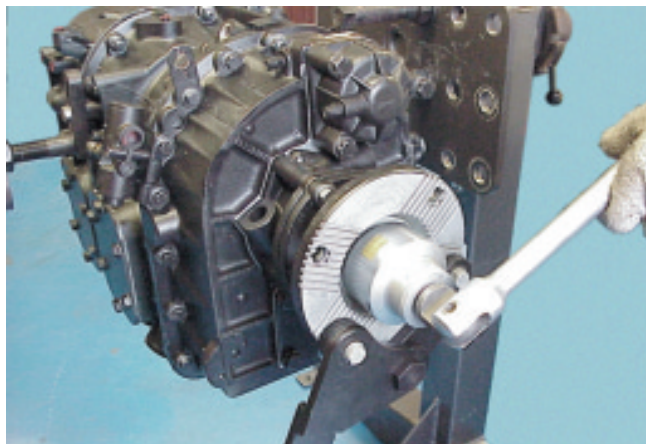

44. Turn the transmission to the horizontal position. Remove the drive flange retaining nut and temporary spacer, install a new nut and using the flange holding wrench tighten to the correct torque. DO NOT use an impact wrench.

Note: DO NOT allow the output shaft to be knocked or driven inwards while the nut is slackened or removed or the range change synchroniser sleeve may be displaced and the rollers, plungers and springs fall out of the hub.



45. Rotate the selector block to position the pin uppermost. Install the neutral selector detent plunger and spring or screw-in assembly.

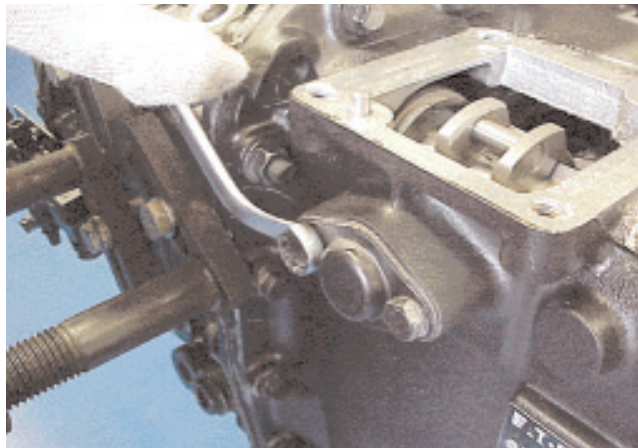

46. Fit the cover plate with a new gasket and tighten the cap screws to the correct torque.

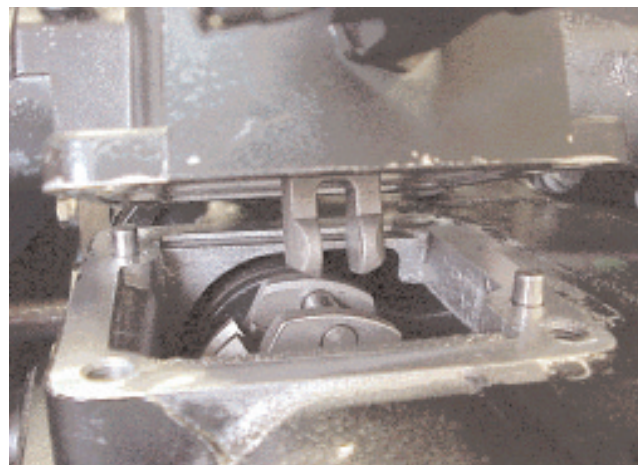

47. If an 'O' ring is fitted as part of the remote control assembly then replace as necessary. Where no 'O' ring is specified apply a light coating of loctite 5900 to the joint face. Refit the remote control ensuring that the selector fork engages in the selector block.

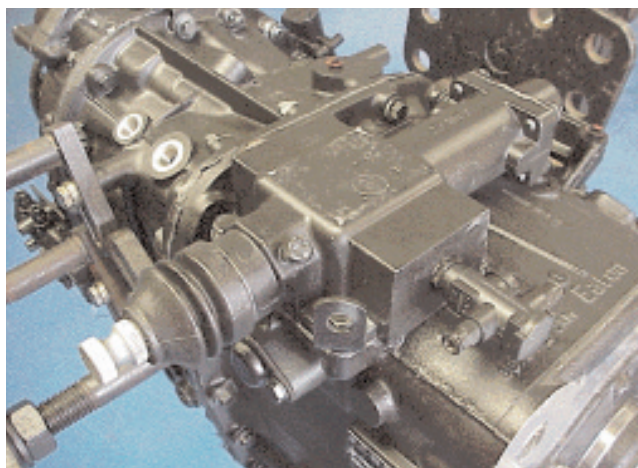

48. Tighten the capscrews to the correct torque.

Main Transmission Overhaul

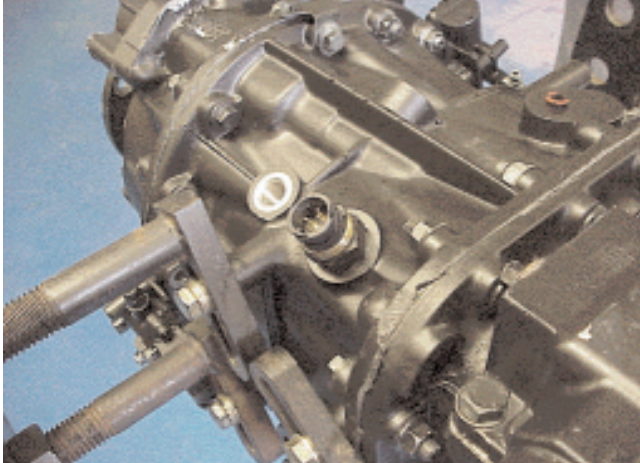

49. Install the reverse lamp switch, tighten to the correct torque.

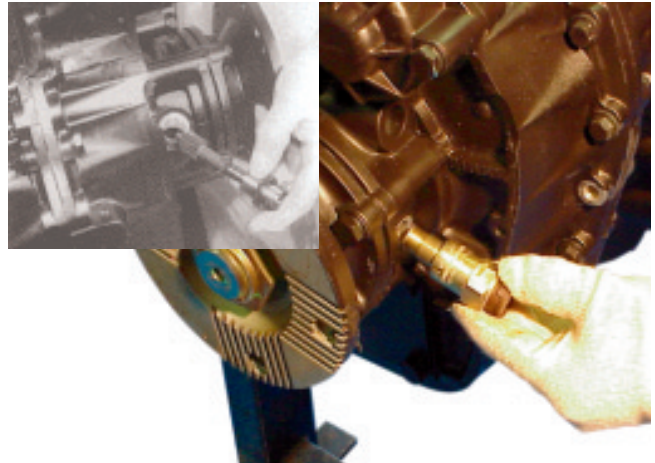

52. Fit the tachograph sender assembly or tachograph pinion and adaptor assembly as required.

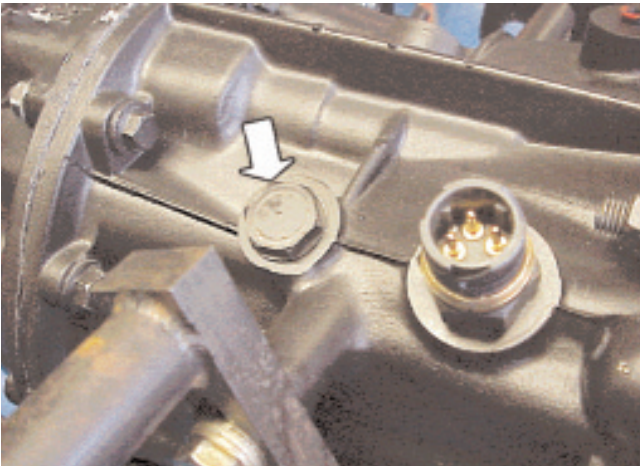

50. If fitted install the neutral switch ball and neutral switch. Alternatively install the ball, washer and plug.

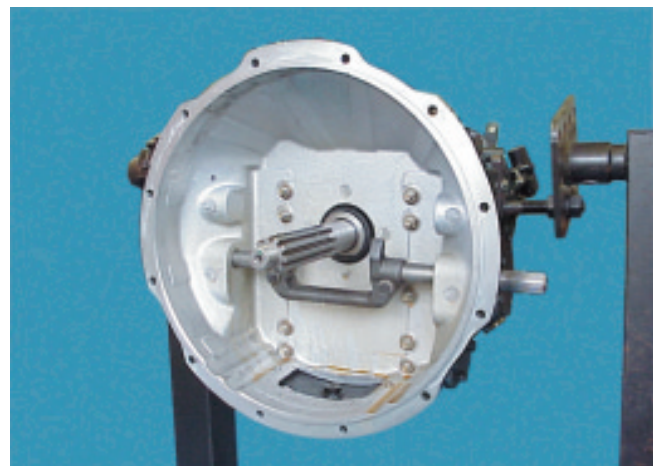

53. Refit the clutch housing assembly. Reconnect all the air lines.



51. If fitted install the range switch ball and range switch. Alternatively install the ball, washer and plug.

Attach the hoist and remove the transmission. Fit any remaining screws and fasteners and tighten to the correct torque. Refit the airline connectors, if removed, using PTFE tape or suitable sealant. Check manually that all gears can be engaged using the shift lever noting that it will be necessary to attach a temporary air supply to check the operation of the range change. Reinstall the transmission and gear linkage.

Section 5 Changing the Input Shaft

Changing the Input Shaft

Changing the input shaft

In some cases in service it may be necessary to renew the input shaft either due to wear on the splines caused by the clutch or for implementing a change in clutch type or hub diameter.

The input shaft can be renewed on direct drive transmissions only without disassembling the transmission other than the removal of the clutch housing by carrying out the following detailed procedure.

Overdrive transmissions require the remote control and the front case assembly to be removed for access.

Exploded view Input shaft assembly

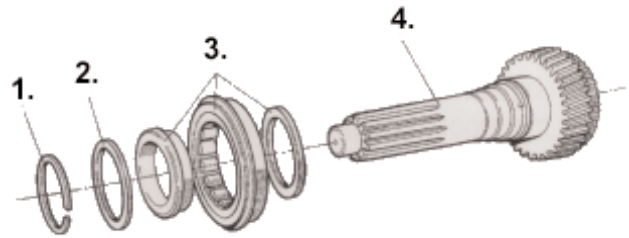

1. Circlip 65 mm diameter
2. Spacer

3. Bearing
4. Input shaft

Disassembly

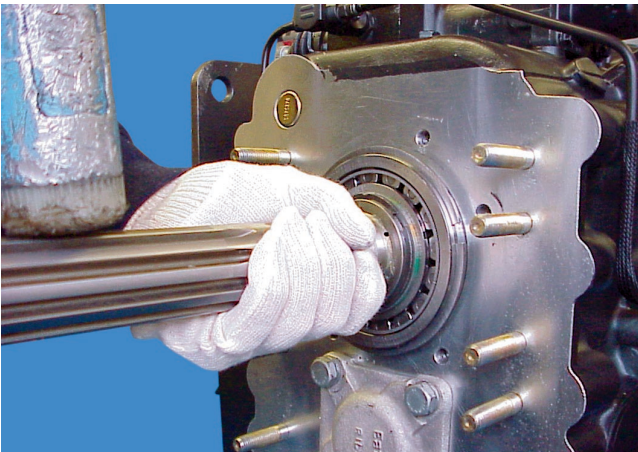

1. Remove the clutch housing assembly. Remove the front bearing cover. Grasp the input shaft firmly and, using a soft mallet, joggle the shaft, gear and bearing out of the case.

Certain specifications have an O-ring seal/plate which must be removed before removing the input shaft front cover.



3. Support the bearing on a press or using a suitable puller press the shaft through the bearing track. Remove the bearing thrust ring.

On horizontal specifications, a spacer is fitted behind the bearing.

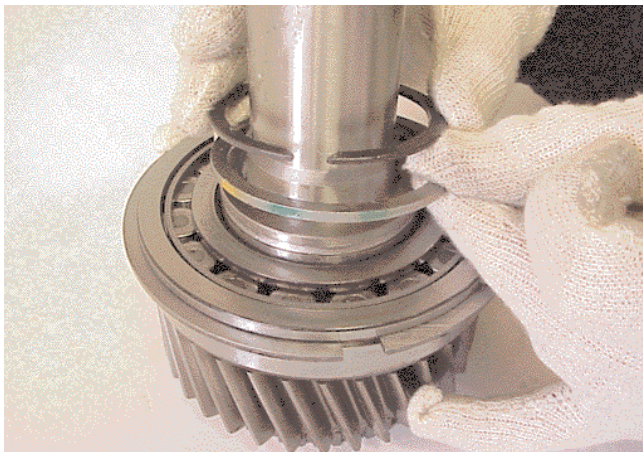

2. Support the input shaft and remove the snap ring. Remove the selective fit spacer.

Changing the Input Shaft

Reassembly

Note: Heat the bearing assembly thoroughly to approximately 85°C before assembly. This greatly eases assembly and in most cases the bearing track will fit over the shaft without the need to drift it in place.



1. Fit the bearing thrust washer, grooved side uppermost. Note: - On horizontal transmissions refit the spacer before fitting the bearing thrust washer.



2. Support the heated bearing assembly, inner track downwards, on a suitable tube and install the input shaft through the bearing.



3. Use the press, or a soft faced mallet to ensure the bearing is firmly against the gear.



4. Place the original spacer against the bearing and check that the snap ring fits into its groove without free play. Check at several places around the diameter of the shaft. If there is too much free play, or the snap ring does not fit into the groove, a new thicker or thinner spacer respectively is required in place of the original.

Graded spacers are available in various sizes ranging from 3,10mm to 3,95mm in increments of 0,05mm.

Part number	Thickness (mm)
8877692	3,10
8877693	3,15
8877694	3,20
8877695	3,25
8877696	3,30
8877697	3,35
8877698	3,40
8877699	3,45
8877700	3,50
8877565	3,60
8877564	3,65
8872484	3,70
8872485	3,75
8872486	3,80
8872487	3,85
8872488	3,90
8872489	3,95

Changing the Input Shaft

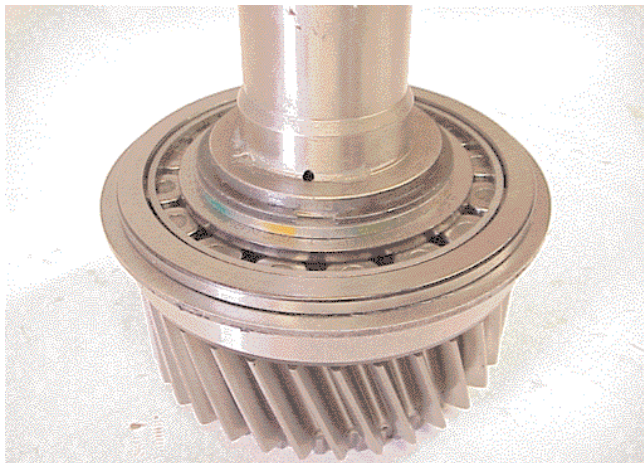

5. When the correct thickness spacer has been selected and fitted, fit the new snap ring.

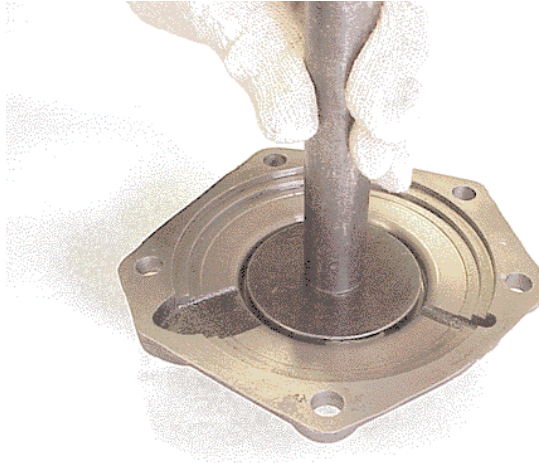

7. Renew the input shaft oil seal. Install the new oil seal into the input shaft bearing front cover using the special tool and apply a light grease to the seal. Press the seal firmly down to the shoulder ensuring the seal is not damaged.

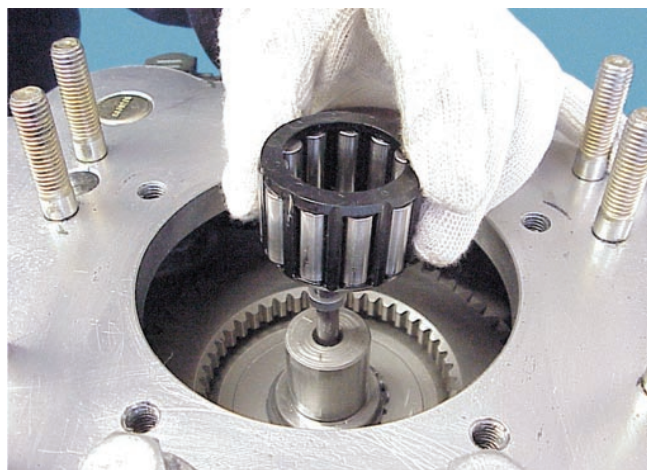

5. Stand the transmission upright. Check the mainshaft spigot bearing and replace if necessary. Check that the roll pin is secure in the mainshaft and that the restrictor, if fitted, is in place. Note: The restrictor is fitted approximately 5mm from the end of the roll pin.

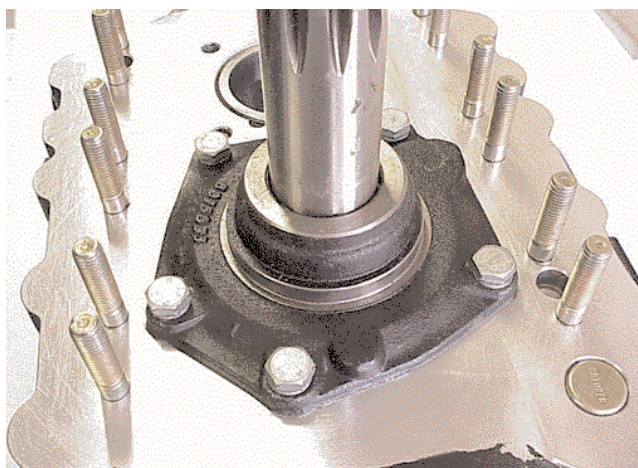

8. Apply flange sealant to the mating face and install the front cover. Tighten the capscrews to the correct torque. Refit the clutch housing assembly.

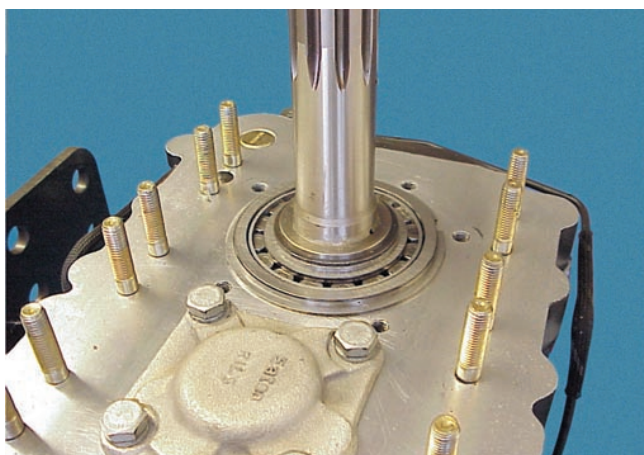

6. Install the input shaft and bearing assembly making sure that the locating teeth on the input gear engage correctly with the teeth of the synchroniser ring.

Section 6 Clutch Housing

Clutch Housing

Clutch housing - Disassembly

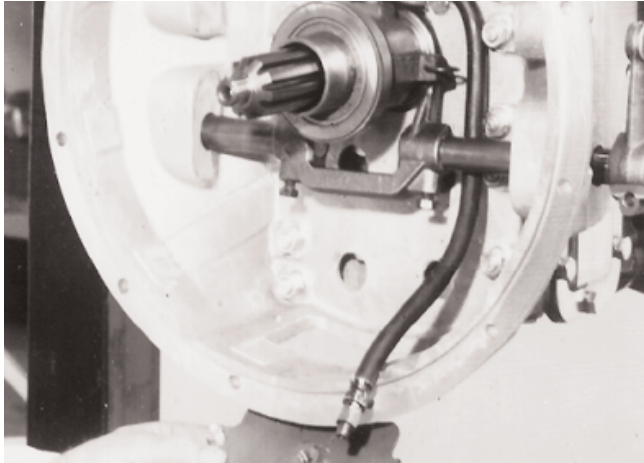

1. Support the transmission, disconnect the lubrication pipe and remove the lower inspection cover.

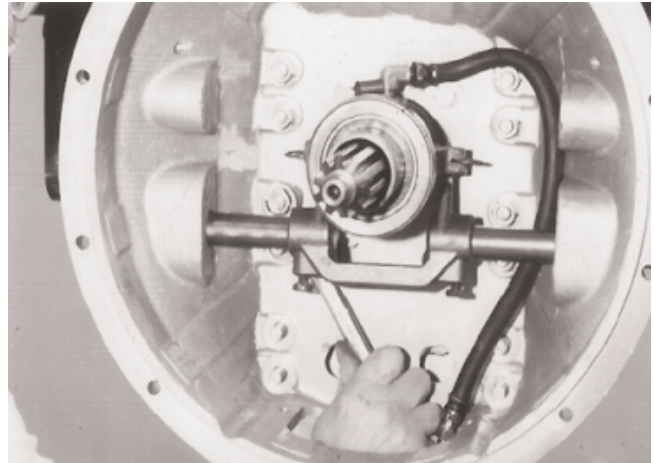

4. Use a ring spanner through the inspection cover hole to undo the nuts behind the cross shaft.

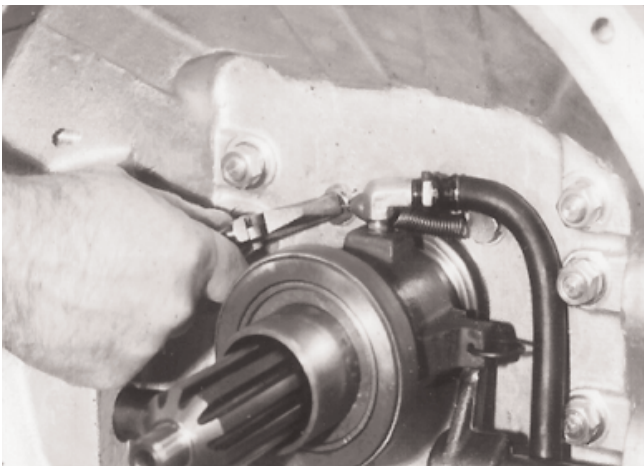

2. Using suitable pliers disconnect the clutch thrust race return springs.

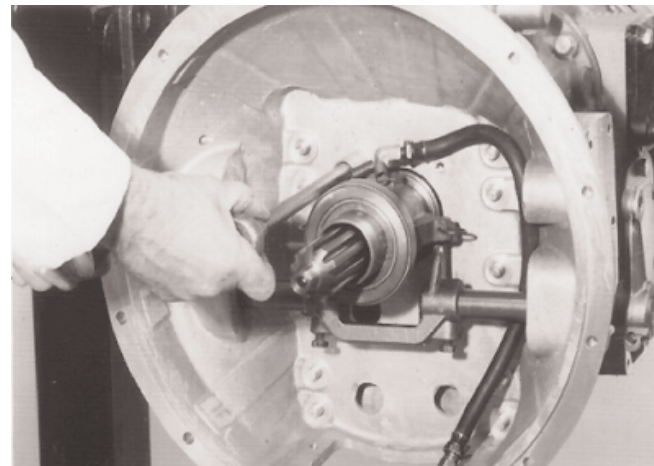

5. Remove the clutch thrust race return spring anchor bolts.

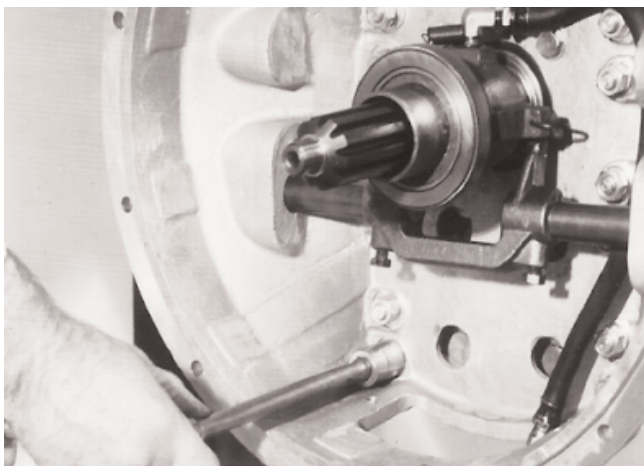

3. Remove the clutch housing retaining nuts and washers.

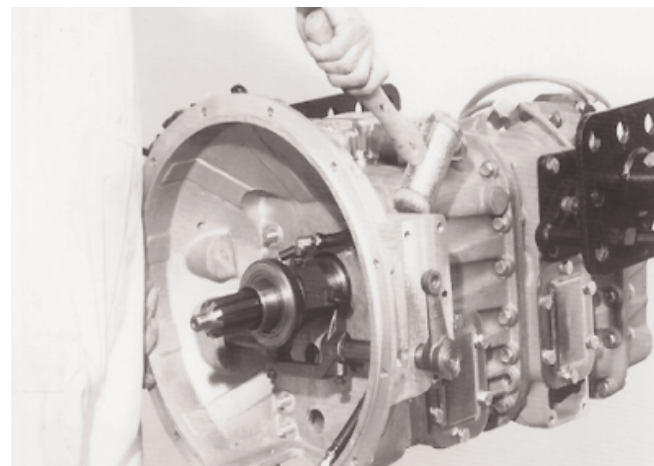

6. Loosen the clutch housing using a soft faced mallet.

Clutch Housing

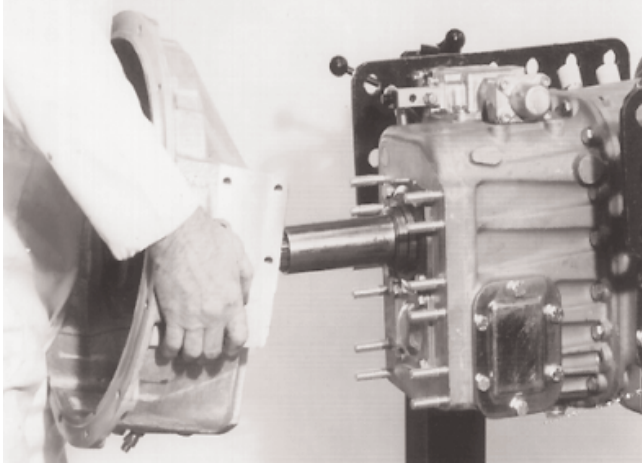

7. Lift off the clutch housing assembly.

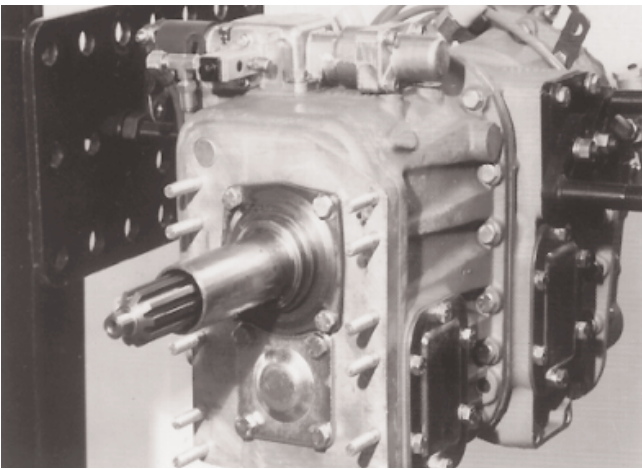

8. Front of transmission with clutch housing removed.

Reassembly

1. Install the clutch housing assembly.
2. Fit and tighten the clutch thrust race return spring anchor bolts to the proper torque.
3. Fit and tighten the clutch housing retaining nuts to the proper torque.
4. Reconnect the clutch thrust race return springs.
5. Refit the lower inspection cover.
6. Reconnect the lubrication pipe and tighten securely.

Copyright Eaton Corporation, 2012. Eaton hereby grant their customers, vendors, or distributors permission to freely copy, reproduce and/or distribute this document in printed format. It may be copied only in its entirety without any changes or modifications. THIS INFORMATION IS NOT INTENDED FOR SALE OR RESALE, AND THIS NOTICE MUST REMAIN ON ALL COPIES.

Note: Features and specifications listed in this document are subject to change without notice and represent the maximum capabilities of the software and products with all options installed. Although every attempt has been made to ensure the accuracy of information contained within, Eaton makes no representation about the completeness, correctness or accuracy and assumes no responsibility for any errors or omissions. Features and functionality may vary depending on selected options.

For spec'ing or service assistance, call 1-800-826-HELP (4357) or visit www.eaton.com/roadranger. In Mexico, call 001-800-826-4357.

Roadranger: Eaton and trusted partners providing the best products and services in the industry, ensuring more time on the road.

Eaton Corporation

Vehicle Group
P.O. Box 4013
Kalamazoo, MI 49003 USA
800-826-HELP (4357)
www.eaton.com/roadranger

Printed in USA

For parts or service call us
Pro Gear & Transmission, Inc.



1 (877) 776-4600

(407) 872-1901

parts@eprogear.com

906 W. Gore St.

Orlando, FL 32805

