

# Fuller Heavy Duty Transmissions TRSM0605

October 2007



*Powering Business Worldwide*

BACKED BY

**Roadranger**

SUPPORT

For parts or service call us  
Pro Gear & Transmission, Inc.



**1 (877) 776-4600**

**(407) 872-1901**

**parts@eprogear.com**

**906 W. Gore St.**

**Orlando, FL 32805**







# Service Manual

- Operation
- Lubrication
- Maintenance
- Repair

## RT-613 Series

### Fuller Twin Countershaft Roadranger<sup>®</sup> Transmissions

**TABLE OF CONTENTS**

Designations .....	3	Inspection .....	47
Description .....	4	Reassembly Precautions .....	49
Specifications .....	4	Reassembly Instructions	
Gear Ratios .....	5	I. Front Section .....	50
Operation .....	6	A. Right Reverse Idler Gear .....	50
Lubrication .....	8	B. Countershafts .....	51
Check Chart .....	10	C. Mainshaft .....	54
Disassembly Precautions .....	11	D. Mainshaft Installation .....	58
Disassembly Instructions		E. Clutch Shaft .....	60
I. Shifting Controls .....	12	F. Right Countershaft Bearings .....	61
A. Air System .....	13	G. Left Reverse Idler Gear .....	61
B. Gear Shift Lever Housing .....	16	II. Auxiliary Intermediate Housing .....	62
C. Shift Bar Housing .....	17	A. Auxiliary Drive Gear Assembly .....	62
II. Companion Flange and Clutch Housing .....	20	B. Intermediate Section .....	63
III. Auxiliary Rear Housing .....	22	III. Auxiliary Rear Housing .....	66
A. Rear Housing .....	22	A. Tailshaft and Rear Bearing Assembly .....	66
B. Auxiliary Shift Cylinder .....	26	B. Synchronizer Assembly .....	69
C. Synchronizer Assembly .....	28	C. Auxiliary Shift Cylinder .....	70
D. Tailshaft and Low Speed Gear Assembly .....	29	D. Installation of the Rear Housing .....	72
IV. Auxiliary Intermediate Housing .....	32	IV. Companion Flange and Clutch Housing .....	75
A. Housing and Gearing .....	32	V. Shifting Controls .....	76
B. Auxiliary Drive Gear Assembly .....	35	A. Shift Bar Housing .....	76
V. Front Section .....	36	B. Gear Shift Lever Housing .....	79
A. Right Countershaft Bearings .....	36	C. Air System .....	80
B. Clutch Shaft .....	38	Range Shift Air System .....	83
C. Left Reverse Idler Gear .....	40	Tool Reference .....	92
D. Mainshaft .....	41		
E. Countershaft Assemblies .....	45		
F. Right Reverse Idler Gear .....	46		

## LETTER DESIGNATIONS

- “R” — Roadranger® transmission.
- “T” — Twin Countershaft type.
- “O” — Indicates overdrive.

Unless stated otherwise, this manual applies to all models in the RT-613 series which includes: RT-613, RTO-613.

### NOTE

**Illustrated parts lists with parts numbers are available upon request.**

## DESCRIPTION

## DESCRIPTION

Models in the RT-613 series are twin countershaft, Roadranger transmissions with 13 forward speeds and 3 reverse.

These units consist of a 5-speed front section and a 3-range auxiliary section.

Ratios in the front section are used once through INTERMEDIATE range of the auxiliary and once through DIRECT range. This provides a simple Roadranger repeat shift pattern.

All speeds are controlled with one lever. The range selection is made with a 3-position selector valve mounted on top of the gear shift lever.

The twin countershaft design, developed by Fuller, splits torque evenly between two countershafts, reducing gear tooth pressure and wear. The floating mainshaft gears of this design eliminate gear bushings and sleeves as gears "float" between mating gears on the countershafts.

## FLOATING GEAR PRINCIPLE

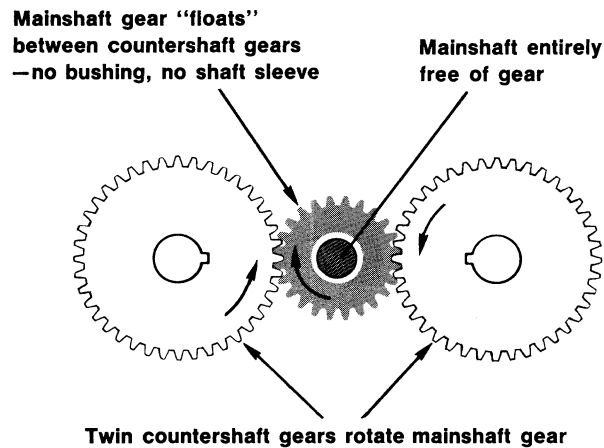

## SPECIFICATIONS

Speeds — 13 forward, 3 reverse.

Torque Capacity — 600 lb.-ft.

Clutch Housing Size — SAE No. 2, gray iron, deep only, 6-5/8", for push or pull type clutches.

Power Take-off —

Openings: Two SAE standard for 6/8 pitch gears.

Right Side: Regular duty type, 6 bolt. PTO shaft projections limited.

Bottom Side: Heavy duty type, 8 bolt.

PTO Gear Speeds —

Right and Bottom: 33-tooth 6/8 pitch gears turning at .723 engine speed.

Weight — 620 lbs.

Length — 34-11/16" from face of clutch housing to end of splines on tailshaft.

Oil Capacity — 16 pints, depending upon inclination of engine and transmission. There are two internal oil troughs for improved lubrication.

## GEAR RATIOS

	Speed	RT-613 Ratio	% Step	RTO-613 Ratio	% Step
Direct Range	13th	1.00		.80	
			24		25
	12th	1.24		1.00	
			29		29
	11th	1.60		1.29	
Range Shift			28		28
	10th	2.05		1.65	
			28		27
	9th	2.62		2.11	
			26		28
Intermediate Range	8th	3.29		2.65	
			24		24
	7th	4.09		3.29	
			29		29
	6th	5.26		4.24	
Range Shift			28		28
	5th	6.74		5.43	
			28		28
Low Range	4th	8.64		6.96	
			27		27
	3rd	10.96		8.83	
			28		28
	2nd	14.04		11.31	
		28		28	
	1st	18.00		14.50	
	Dir. Rev.	2.77			
	Inter. Rev.	9.12			
	Low Rev.	19.00			

# OPERATION

In the following instructions it is assumed that the driver is familiar with motor trucks and tractors, and that he can coordinate the necessary movements of the shift lever and clutch pedal to make progressive and selective gear engagements in either direction, up or down.

## RT-613 Gear Shift Lever Pattern and Selector Valve Positions

Use Normal Double Clutching Procedures Between Shifts.

Shift this Pattern with Selector Valve in LOW Range

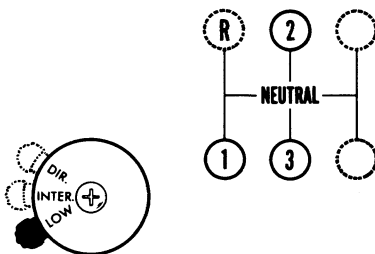

Shift this Pattern with Selector Valve in INTERMEDIATE Range

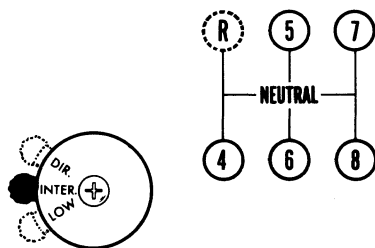

Shift this Pattern with Selector Valve in DIRECT

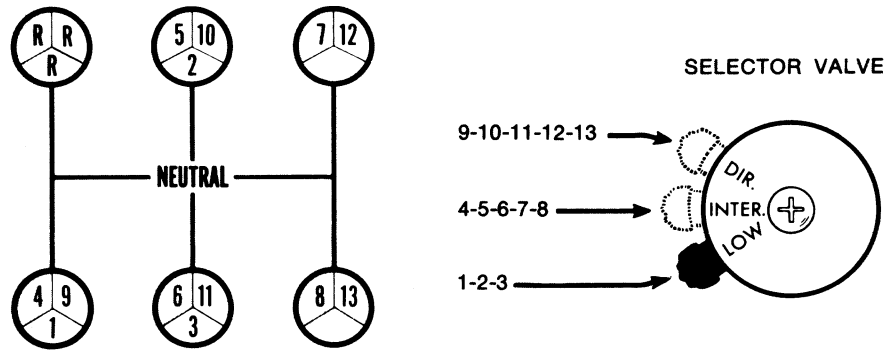
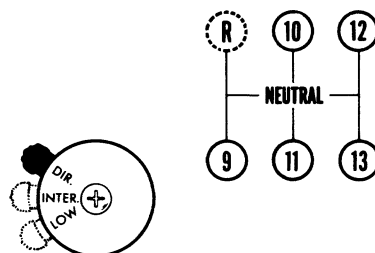

NOTE: For RTO-613 models, the 7/12 and 8/13 speed locations are reversed.

## UPSHIFTING

1. With the transmission in neutral, start engine and bring vehicle's air pressure to normal.
2. Make sure the selector valve is in the LOW range position.

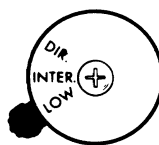

4. Shift from 1st speed through 2nd and to the 3rd speed gear position.

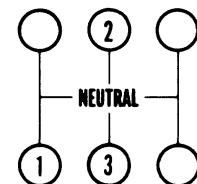

3. Shift into the 1st speed gear position. See page relating to transmission counter-shaft brake.

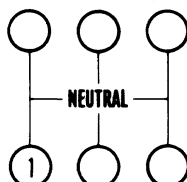

5. Move the selector from LOW to INTERMEDIATE range, and immediately shift to the 4th speed gear position. After the selector valve is moved, the auxiliary will shift as soon as there is a relief in torque.

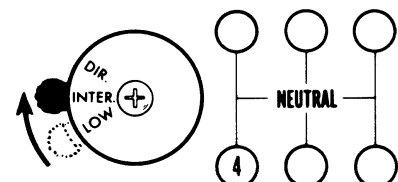

6. Shift progressively from 4th through 5th, 6th, and 7th to the 8th speed gear position.

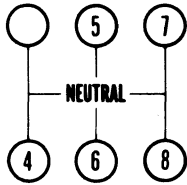

7. Move the selector from INTERMEDIATE to DIRECT range.

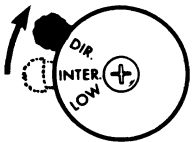

8. Move the gear shift lever to the 9th speed gear position. The auxiliary section will automatically shift from INTERMEDIATE to DIRECT when the gear shift lever reaches neutral.

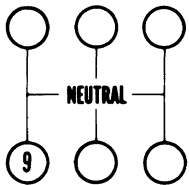

9. Shift upward from 9th through 10th, 11th and 12th to the 13th speed gear position.

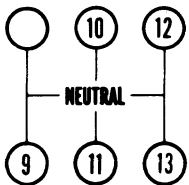

**DOWNSHIFTING**

1. Move the shift lever from the 13th speed position through each successive lower speed to the 9th speed gear position.

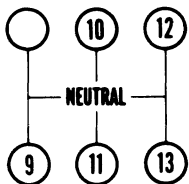

2. When in 9th and ready for the next down shift, move the selector valve from DIRECT to INTERMEDIATE range.

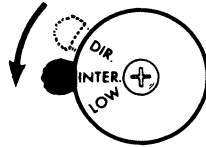

3. Move the shift lever to the 8th speed gear position. As the lever reaches neutral the auxiliary will automatically shift from DIRECT to INTERMEDIATE range.

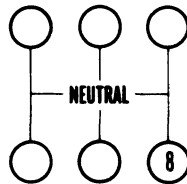

4. Shift from the 8th speed gear position through each gear and to 4th.

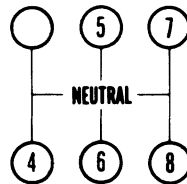

5. Move the selector valve from INTERMEDIATE to LOW and immediately shift to the 3rd speed gear position. The auxiliary section will shift as soon as there is a relief in torque.

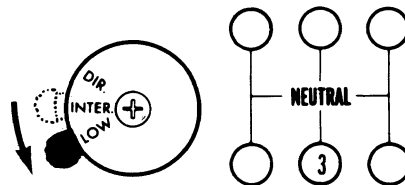

6. Downshift from 3rd to 2nd and to 1st.

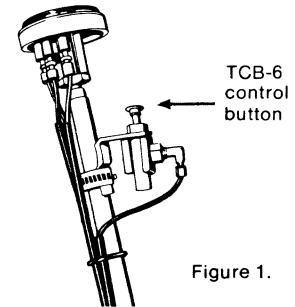
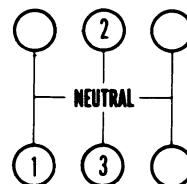

Figure 1.

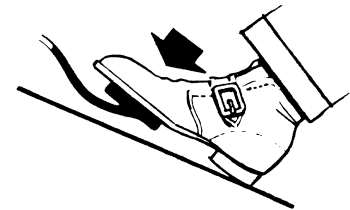

Figure 2.

Model RT-613 transmission is equipped with either a Transmission Countershaft Brake, or an Upshift Clutch Brake.

**Transmission Countershaft Brake . . .**

Model TCB-6 or TCB-8 . . . To be used only to assist *initial* gear engagement in first or reverse when vehicle is standing still.

Disengage clutch, press down control button and shift into first or reverse. (Figure 1.)

This is an air-operated mechanical brake which slows down the transmission gearing by forcing a piston against the transmission's PTO gear.

Model TCB-6 mounts on the 6-bolt PTO opening, model TCB-8 mounts on the 8-bolt PTO opening.

**Do not use an upshift brake. Use only when vehicle is standing still.**

**Upshift Clutch Brake . . .**

To provide a brake for initial gear engagement in first or reverse, and to provide a brake capable of use for upshifting when required with adverse conditions.

Brake is activated by extreme clutch pedal travel during regular upshift sequence. (Figure 2.)

The upshift clutch brake is a disc-type brake incorporated into the clutch and transmission drive gear cover assemblies.

When activated the upshift clutch brake slows down the transmission gearing.

**Do not use when downshifting. Do not use as a brake to slow vehicle.**



# LUBRICATION

Proper lubrication procedures are the key to a good all-round maintenance program. If the oil is not doing its job, or if the oil level is ignored, all the maintenance procedures in the world are not going to keep the transmission running or assure long transmission life.

Oil is important, because here are some of the things it must do:

- Provide a protective film — To protect surface of heavily loaded parts such as gear teeth and bearings, thus preventing metal to metal contact which causes scoring, scuffing and seizure.



- Act as a coolant — To dissipate heat.
- Have sufficient fluidity — To follow, coat and cushion all loaded surfaces.
- Be chemically stable — To withstand heat and agitation without separation, gumming-up, oxidizing or corroding.
- Be non-foaming — To prevent excessive foam and increased volume under severe conditions.
- Be free of sediment and water — To prevent sludge and rust.



Fuller Transmissions are designed so that the internal parts operate in a bath of oil circulated by the motion of gears and shafts. Grey iron parts have built-in channels where needed, to help lubricate bearings and shafts.

Thus, all parts will be amply lubricated if these procedures are closely followed:

1. Maintain oil level. Inspect regularly.
2. Change oil regularly.
3. Use the correct grade and type of oil.
4. Buy from a reputable dealer.

## Lubrication Change and Inspection HIGHWAY USE

First 3,000 to 5,000 miles (4827 to 8045 Km)	Change transmission oil on new units.
Every 5,000 miles (8045 Km)	Inspect Oil Level. Check for leaks.
Every 50,000 miles (80450 Km)	Change transmission oil.

## OFF-HIGHWAY

First 30 hours	Change transmission oil on new units.
Every 40 hours	Inspect oil level. Check for leaks.
Every 500 hours	Change transmission oil where severe dirt conditions exist.
Every 1,000 hours	Change transmission oil (Normal off-highway use).

Change oil filter element, if so equipped, at each oil change.

## Recommended Lubricants ON-HIGHWAY VEHICLES

Type	Grade	Temperature
Heavy Duty Engine Oil MIL-L-2104C, or MIL-L-46152, or API-SE, or API-CC	SAE 50 or SAE 40 SAE 30	Above + 10°F. (-12.5°C.) Below + 10°F.
Mineral Gear Oil R and O Type	SAE 90 SAE 80W	Above + 10°F. Below + 10°F.

## OFF-HIGHWAY

Heavy Duty Engine Oil MIL-L-2104C, or MIL-L-46152, or API-SE, or API-CC	SAE 50 or SAE 40 SAE 30	Above + 10°F. Below + 10°F.
---	----------------------------	--------------------------------

### Special Recommendation — For extreme cold weather where temperature is consistently below 0° F.

Heavy Duty Engine Oil MIL-L-2104C, or MIL-L-46152, or API-SE, or API-CC	SAE 20W	Below 0°F. (-18°C.)
---	---------	------------------------

## Miscellaneous Lubricants

O-Rings and Surfaces — Dow Corning #200 Silicone, 30,000 Centistokes. Union Carbide L-45 Silicone, 30,000 Centistokes.

**Proper Oil Level**

Make sure oil is level with filler opening. Because you can reach oil with your finger does not mean oil is at proper level.

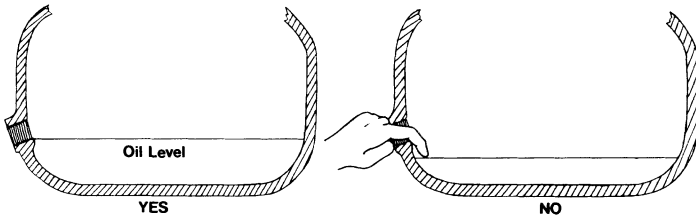

**Draining Oil**

Drain transmission while oil is warm. To drain oil remove the drain plug at bottom of case. Clean the drain plug before re-installing.

**Refilling**

Clean area around filler plug and remove plug from side of case. Fill transmission to the level of the filler opening. If transmission has two filler openings, fill to level of rear opening on single countershaft models; fill to level of both openings on twin countershaft models.

The exact amount of oil will depend on the transmission inclination and model. *In every instance, fill to the level of the filler opening.*

Do not over fill — this will cause oil to be forced out of the case through mainshaft openings.

**Adding Oil**

It is recommended that types and brands of oil not be intermixed because of possible incompatibility.

**Operating Temperature**

It is important that the transmission operating temperature does not exceed 250° F. (120° C.) for an extended period of time. Operating temperatures above 250° F. will cause breakdown of the oil and shorten transmission life.

The following conditions in any combination can cause operating temperatures of over 250° F:

- (1) operating consistently at roadspeeds under 20 MPH,
  - (2) high engine RPM,
  - (3) high ambient temperature,
  - (4) restricted air flow around transmission,
  - (5) exhaust system too close to transmission,
  - (6) high horsepower, overdrive operation.
- High operating temperatures may require more frequent oil changes.

External cooler kits are available to keep the transmission operating temperature under 250° F. when the conditions described above are encountered.

**Proper Lubrication**

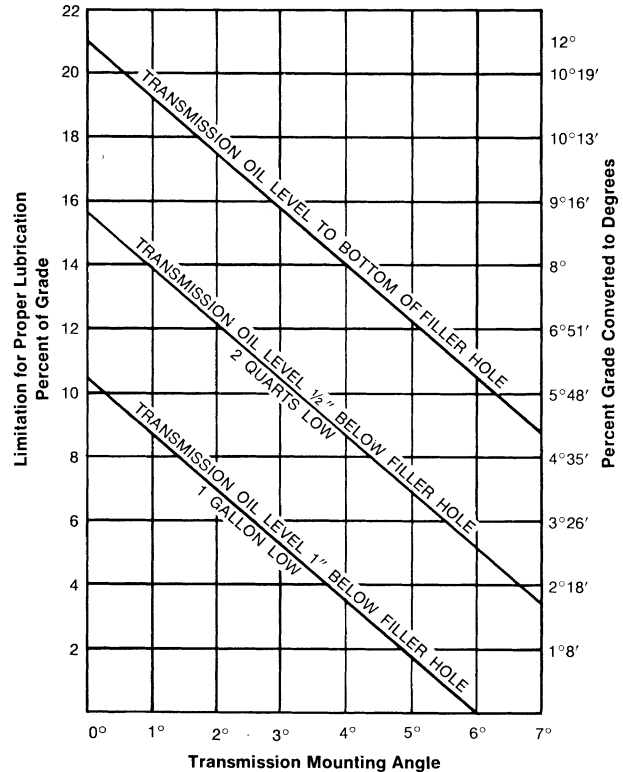

If the transmission operating angle is more than 12 degrees, improper lubrication can occur. The operating angle is the transmission mounting angle in the chassis plus the percent of upgrade (expressed in degrees).

The above chart illustrates the safe percent of upgrade on which the transmission can be used with various chassis mounting angles. For example: If you have a 4 degree transmission mounting angle, then 8 degrees (or 14 percent of grade) is equal to the limit of 12 degrees. If you have a 0 degree mounting angle, the transmission can be operated on a 12 degree (21 percent) grade.

Anytime the transmission operating angle of 12 degrees is exceeded for an extended period of time the transmission should be equipped with an oil pump or cooler kit to insure proper lubrication.

Note on the chart the effect low oil levels can have on safe operating angles. Allowing the oil level to fall 1/2" below the filler plug hole reduces the degree of grade by approximately 3 degrees (5.5 percent).

**Proper Lubrication Levels are Important!**

# PREVENTIVE MAINTENANCE CHECK CHART

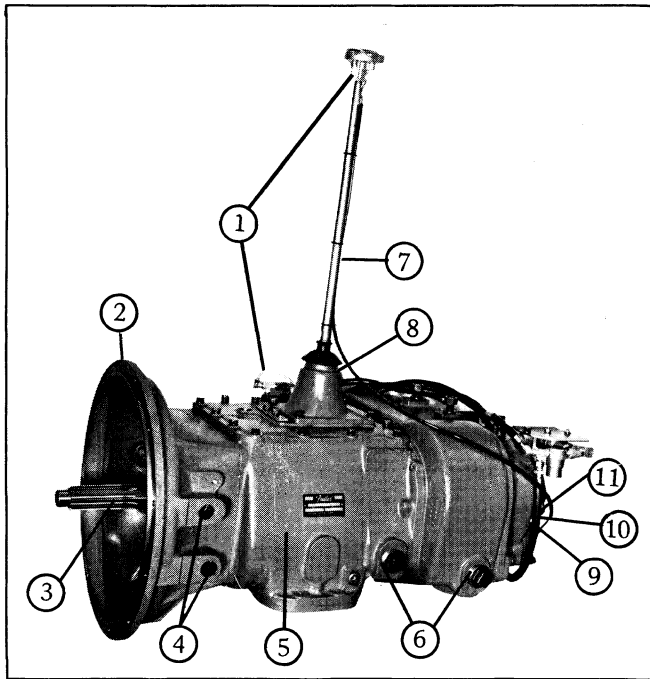

## CHECKS WITHOUT PARTIAL DISASSEMBLY OF CHASSIS OR CAB

### 1. Air System and Connections

- a. Check for leaks, worn air lines, loose connections and capscrews. See Air Systems.

### 2. Clutch Housing Mounting

- a. Check all capscrews in bolt circle of clutch housing for looseness.

### 3. Clutch Release Bearing

- a. Remove hand hole cover and check radial and axial clearances in release bearing.
- b. Check relative position of thrust surface of release bearing with thrust sleeve on push type clutches.

### 4. Clutch Pedal Shaft and Bores

- a. Pry upward on shafts to check wear.
- b. If excessive movement is found, remove clutch release mechanism and check bushings in bores and wear on shafts.

### 5. Gear Lubricant

- a. Change at specified service intervals.
- b. Use only gear oils as recommended. See Lubrication section.

### 6. Filler and Drain Plugs

- a. Remove filter plugs and check level of lubricant at specified intervals. Tighten filler and drain plugs securely.

### 7. Gear Shift Lever

- a. Check for looseness and free play in housing. If lever is loose in housing, proceed with Check No. 8.

### 8. Gear Shift Lever Housing Assembly

- a. Remove air lines at air valve and remove the gear shift lever housing assembly from transmission.
- b. Check tension spring and washer for set and wear.
- c. Check the gear shift lever pivot pin and pivot pin slot for wear.
- d. Check bottom end of gear shift lever for wear and check slot of yokes and blocks in shift bar housing for wear at contact points with shift lever.
- e. If so equipped, check O-ring in housing for wear or cracks.

## CHECKS WITH DRIVE LINE DROPPED

### 9. Universal Joint Companion Flange Nut

- a. Check for tightness. Tighten to recommended torque.

## CHECKS WITH UNIVERSAL JOINT COMPANION FLANGE REMOVED

### 10. Output Shaft

- a. Check splines for wear from movement and chucking action of the universal joint companion flange.
- b. Pry upward against output shaft to check radial clearance in mainshaft rear bearing.

### 11. Mainshaft Rear Bearing Cover

- a. Check oil seal for wear.

# GENERAL PRECAUTIONS FOR DISASSEMBLY

**IMPORTANT: Read this section before starting the detailed disassembly procedures.**

It is assumed in the detailed disassembly instructions that the lubricant has been drained from the transmission, the necessary linkage and air lines removed and the transmission has been removed from the chassis. Removal of the gear shift lever housing assembly is included in the detailed instructions; however, this assembly must also be removed from transmission before removing unit from vehicle.

Air lines from the range shift and splitter gear controls must be disconnected at the transmission before removing unit from vehicle.

*Follow each procedure closely in each section, making use of both the text and pictures.*

1. **BEARINGS** — Carefully wash and relubricate all bearings as removed and protectively wrap until ready for use. Remove bearings with pullers designed for this purpose.



BEARING REMOVED WITH PUNCH, DAMAGED SHIELD.

BEARING REMOVED WITH CHISEL, DAMAGED OUTER RACE.

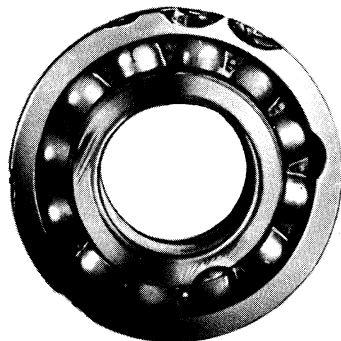

2. **ASSEMBLIES** — When disassembling the various assemblies, such as the mainshaft, countershafts and shifting bar housing, lay all parts on a clean bench in the same sequence as removed. This procedure will simplify reassembly and reduce the possibility of losing parts.

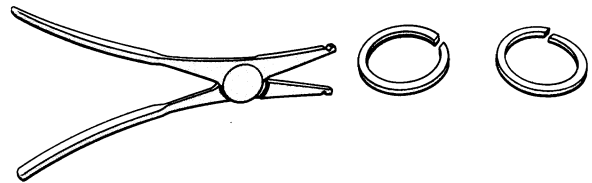

3. **SNAP RINGS** — Remove snap rings with pliers designed for this purpose. Rings removed in this manner can be reused.
4. **INPUT SHAFT** — The clutch or input shaft can be removed without removing the countershafts, mainshaft or drive gear. Refer to page 38.
5. **CLEANLINESS** — Provide a clean place to work. It is important that no dirt or foreign material enters the unit during repairs. The outside of the unit should be carefully cleaned before starting the disassembly. Dirt is abrasive and can damage bearings.
6. **WHEN DRIVING** — Apply force to shafts, housings, etc., with restraint. Movement of some parts is restricted. Do not apply force after the part being driven stops solidly. Use soft hammers and bars for all disassembly work.

# DISASSEMBLY INSTRUCTIONS

## I. SHIFTING CONTROLS

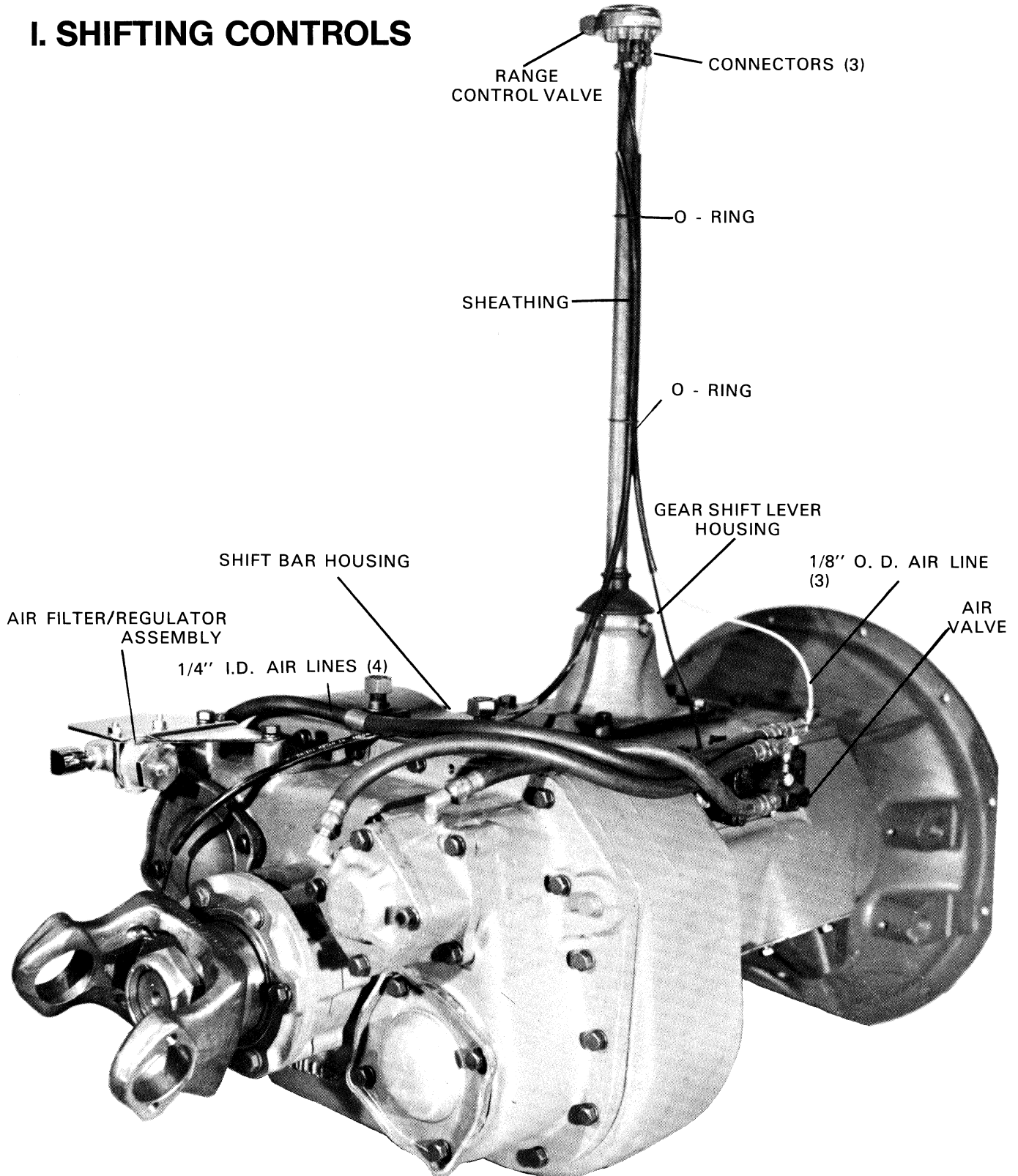

**A. Removal and Disassembly of the Range Shift Air System**

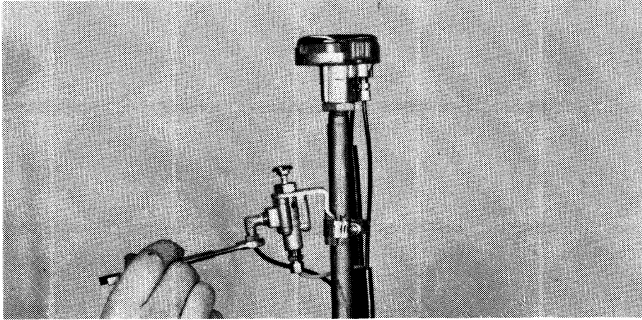

1. If so equipped, disconnect the two 1/8" OD countershaft brake control air lines at the control valve.

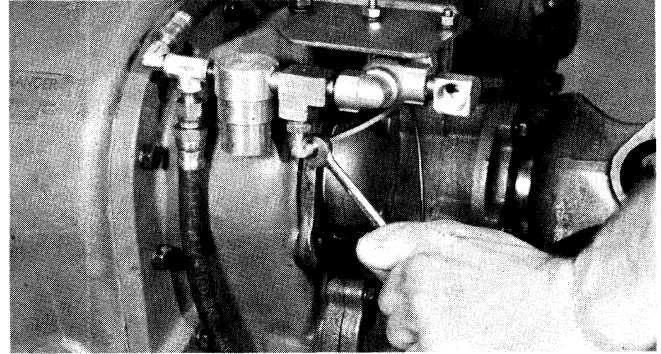

4. Disconnect the 1/8" OD air line at the tee block fitting between the air filter and regulator.

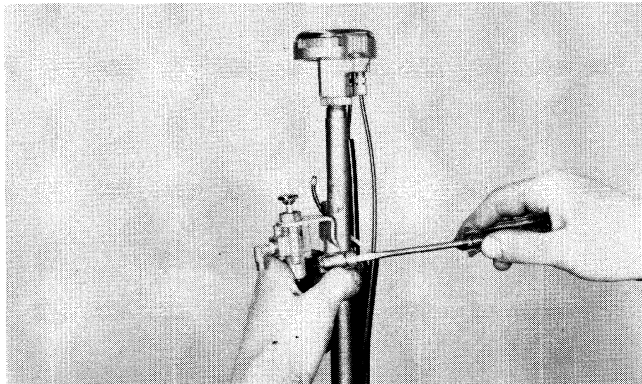

2. Loosen the clamp and remove the countershaft brake control valve from the shifting lever.

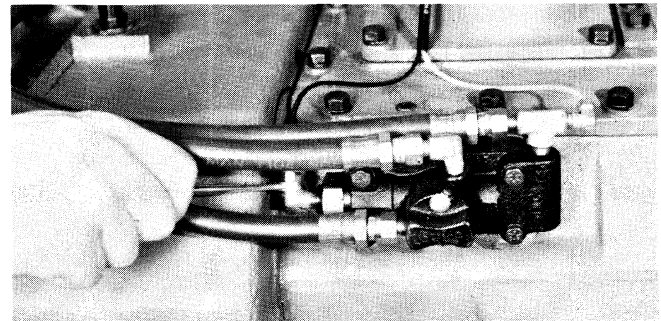

5. Disconnect the 1/8" OD range shift control air line at the rear port of the slave air valve.

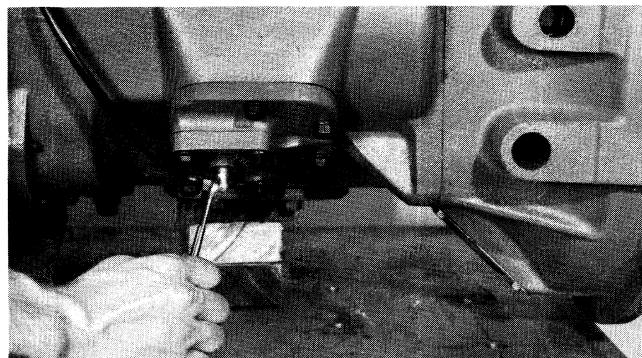

3. Disconnect the 1/8" OD air line at the TCB-6 brake on the right side PTO opening.

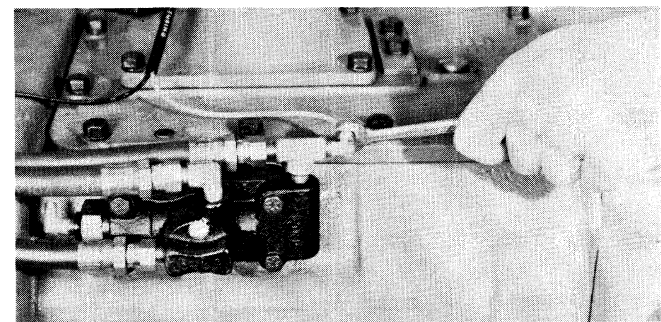

6. Disconnect the 1/8" OD range shift air line at the forward port of the slave air valve.



## DISASSEMBLY – SHIFTING CONTROLS

### A. Removal and Disassembly of the Range Shift Air System – Continued

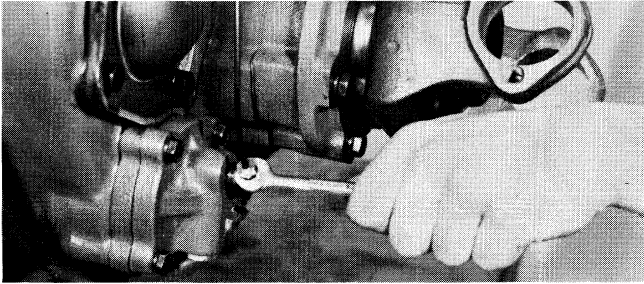

7. Disconnect the  $\frac{1}{8}$ " OD range shift control air line at the intermediate shift cylinder.

NOTE: If desired, the gearshift lever housing, control valve and air lines can now be removed from the shift bar housing as a unit by turning out the four capscrews at the base of the gearshift lever housing.

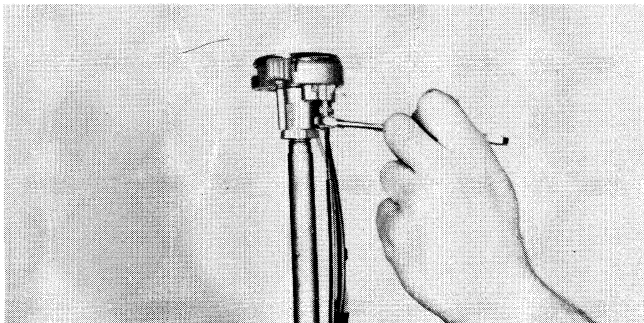

8. Disconnect the three  $\frac{1}{8}$ " OD air lines at the control valve.

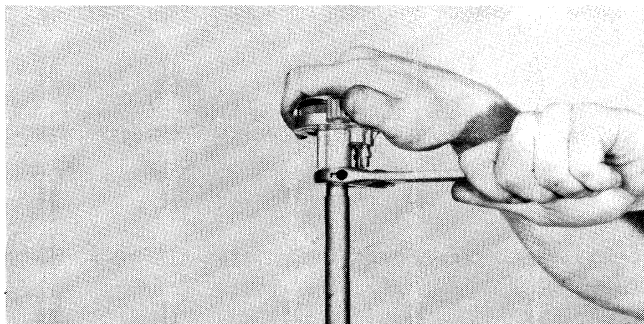

9. Loosen the jam nut and turn the nut and control valve from the shifting lever. Remove the air lines, sheathing and O-rings from the lever.

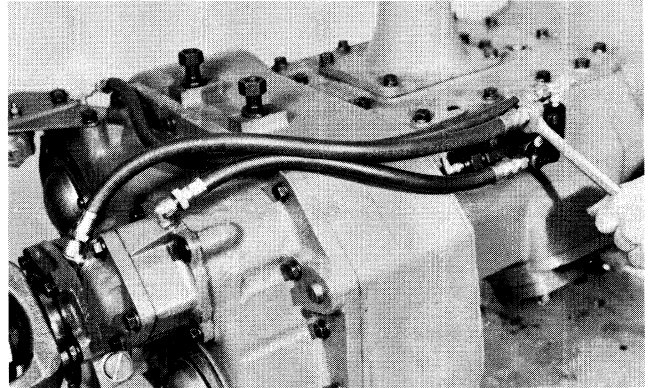

10. Remove the  $\frac{1}{4}$ " ID air line between the air valve and the direct range port of the auxiliary shift cylinder.

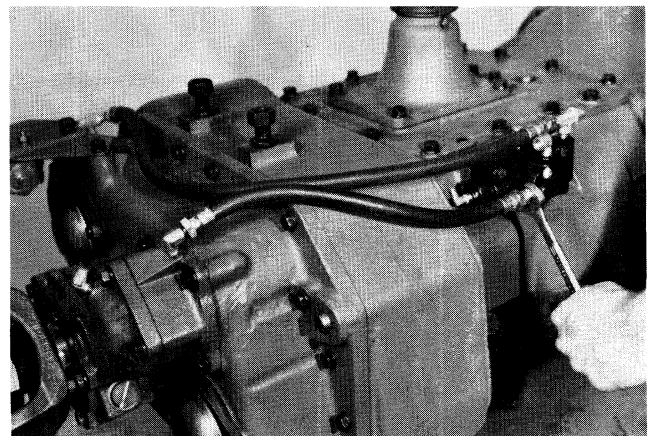

11. Remove the  $\frac{1}{4}$ " ID air line between the air valve and the low range port of the auxiliary shift cylinder.

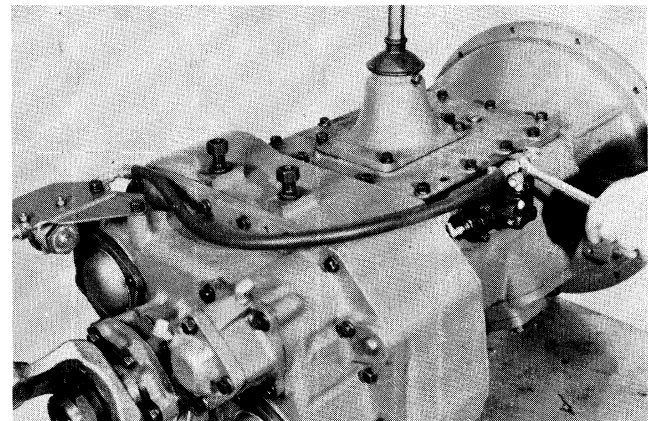

12. Remove the  $\frac{1}{4}$ " ID air line between the air valve and the air filter/regulator assembly. If so equipped, the hose-retaining clamp will have to be removed to allow removal of the air line.

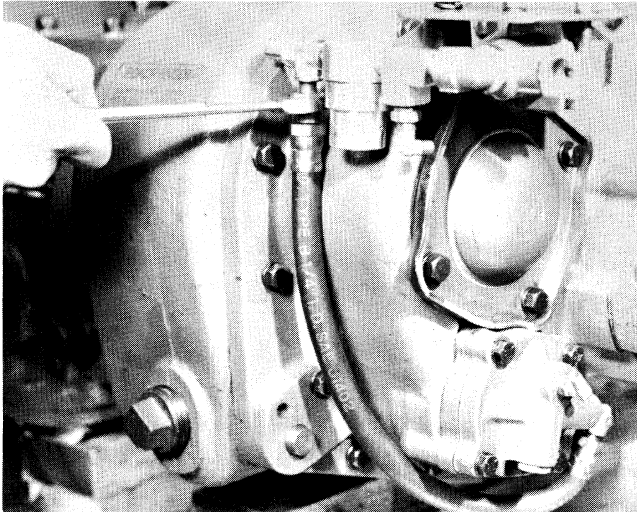

13. Remove the 1/4" ID air line between the air filter/regulator assembly and the intermediate shift cylinder.



16. Remove the hat-type sleeve from the bore in the valve.

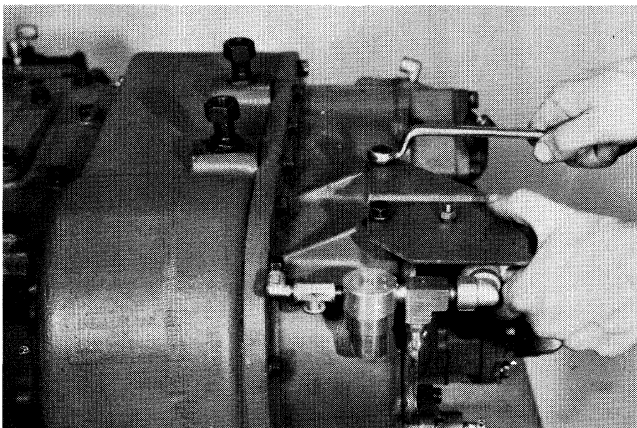

14. Turn out the two cap screws and remove the air filter/regulator assembly. For further disassembly of the unit, refer to page 85.

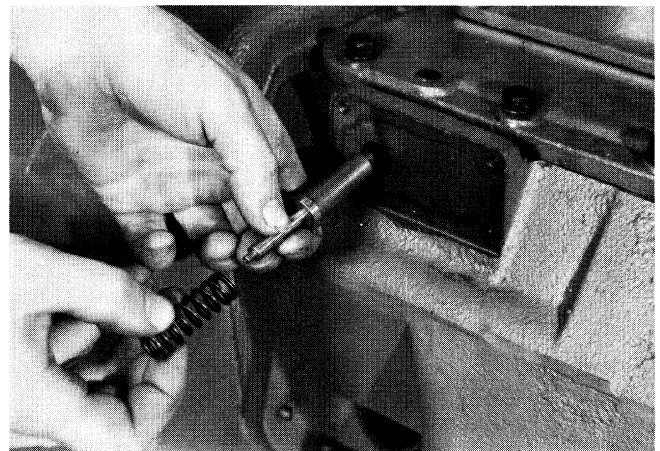

17. Remove the spring and plunger from the bore in the transmission.

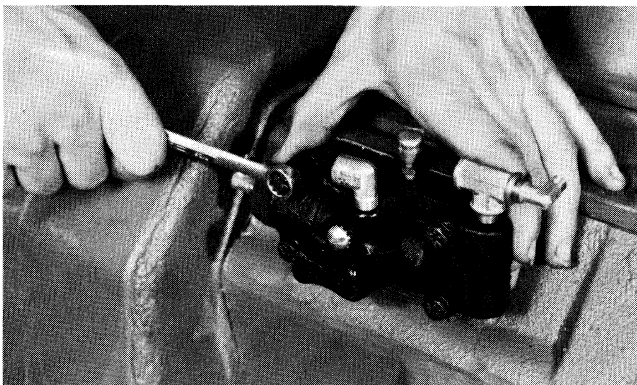

15. Turn out the four retaining cap screws and remove the slave air valve from the transmission. For further disassembly of the valve, refer to page 84.



## DISASSEMBLY – SHIFTING CONTROLS

### B. Removal and Disassembly of the Gear Shift Lever Housing Assembly

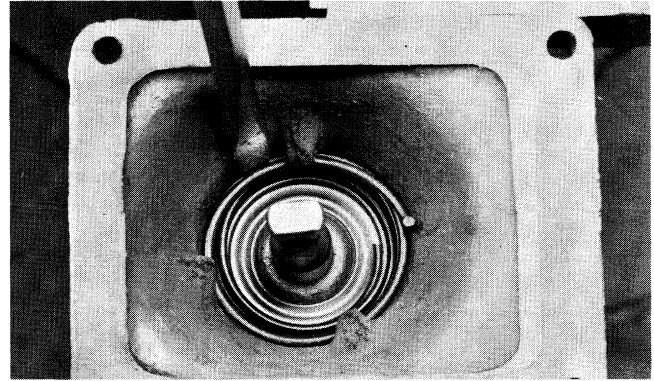
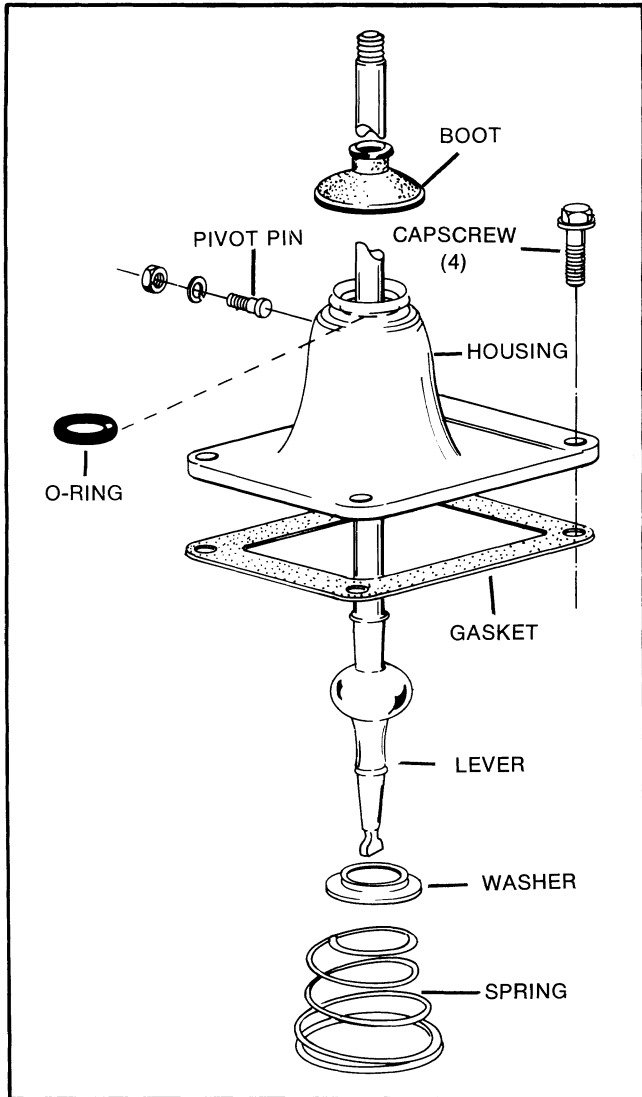

2. Secure the assembly upside down in a vise and remove the tension spring by prying it up and over the spring retainers, one coil at a time.

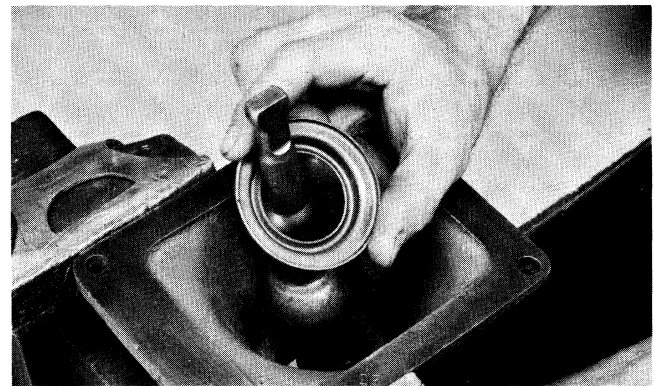

3. Remove the washer and lever from the housing.



4. Remove the housing from the vise and, if necessary, remove the nut, washer, pivot pin, and O-Ring.

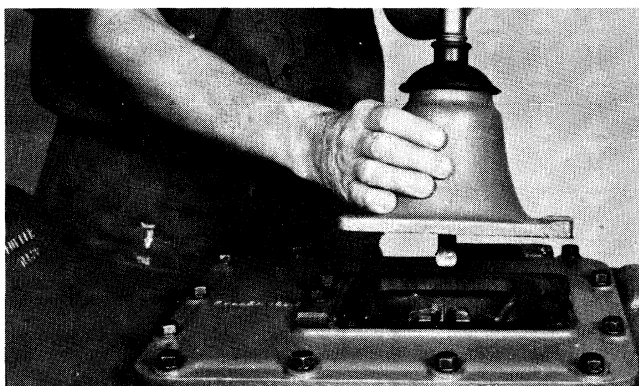

1. Turn out the four retaining capscrews, jar lightly to break the gasket seal, and lift the assembly from the shift bar housing.

C. Removal and Disassembly of the Shift Bar Housing

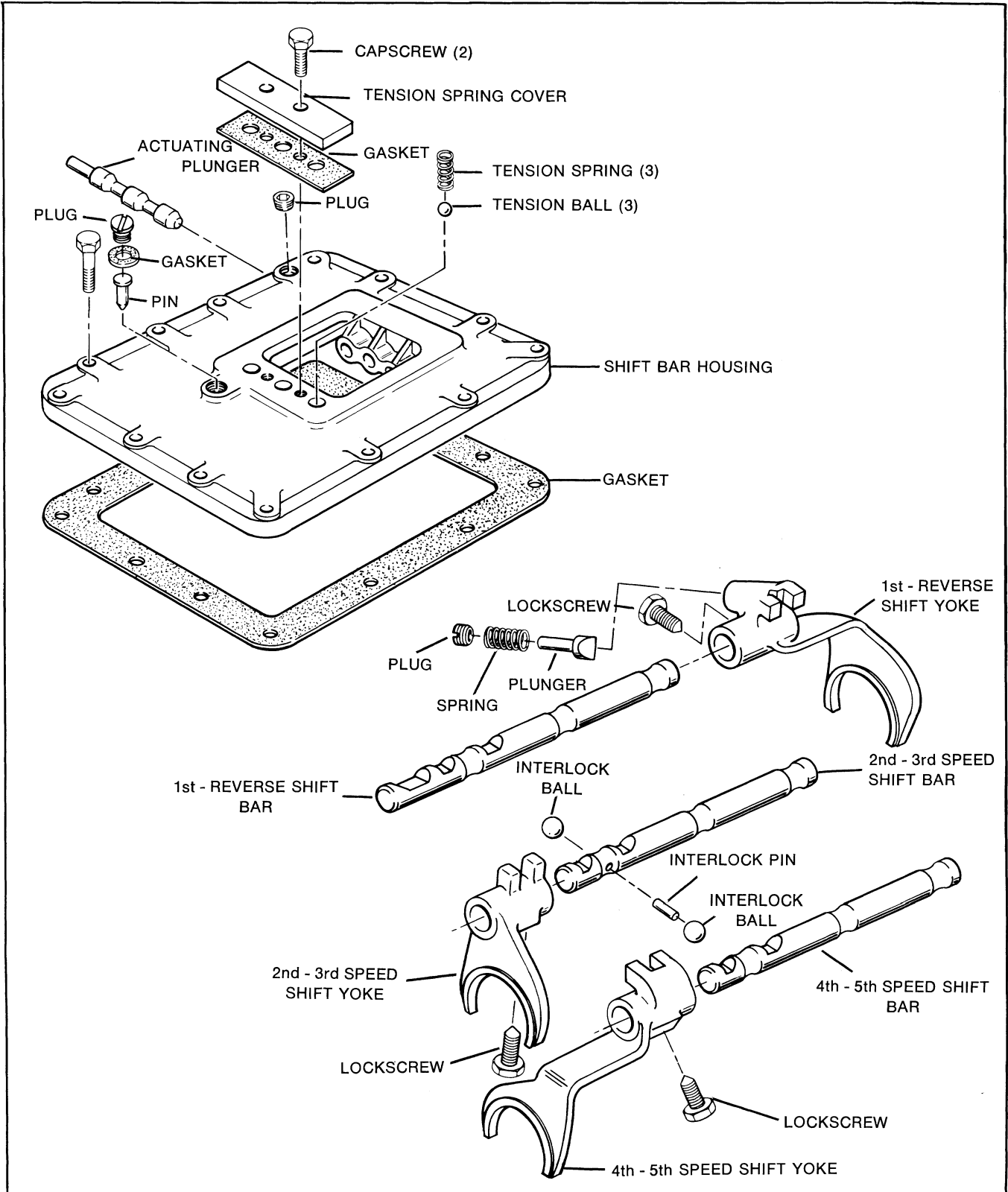

## DISASSEMBLY – SHIFTING CONTROLS

### C. Removal and Disassembly of the Shift Bar Housing – Continued

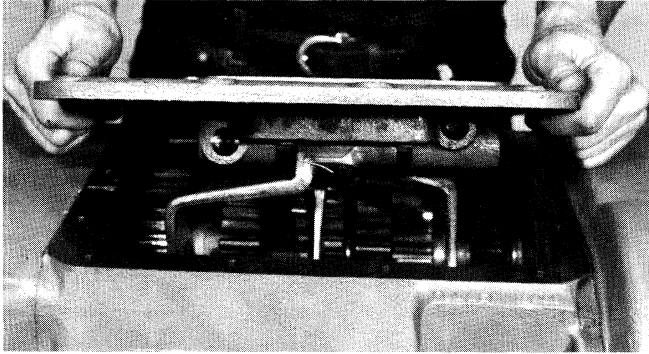

1. Turn out the 13 retaining capscrews, jar to break gasket seal, and remove the shift bar housing from the transmission.

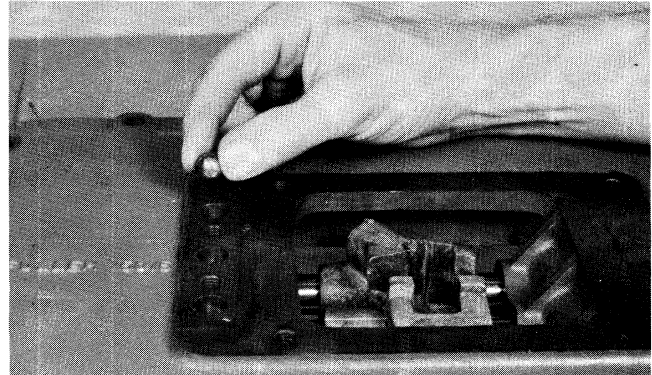

4. Remove the three tension balls located under the springs.

NOTE: For ease of reassembly, lay all parts on a clean bench in order of removal. Bars not being removed must be kept in the neutral position or interlock parts will lock the bars.

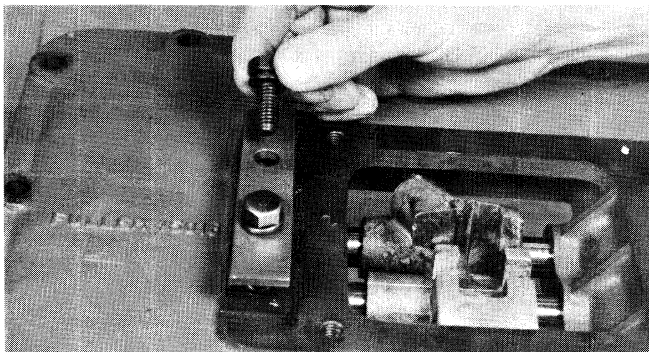

2. Turn out the two capscrews and remove the tension spring cover.

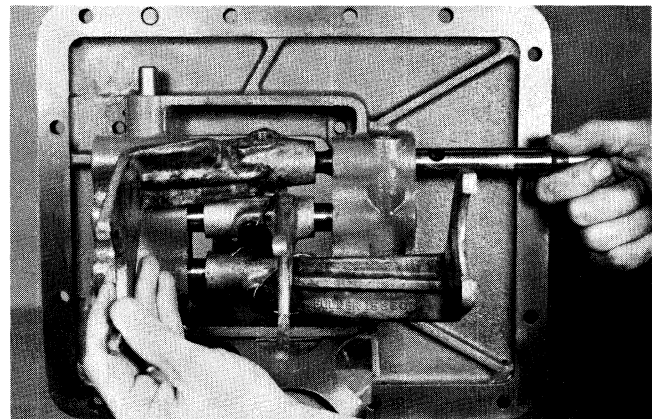

5. Place the shift bar housing in a vise, cut the lockwire, turn out the lockscrew and pull the 1st-reverse shift bar from the housing, removing the yoke.

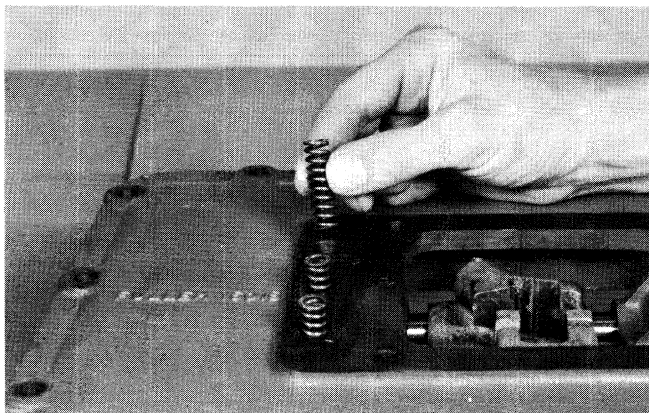

3. Remove the three tension springs.

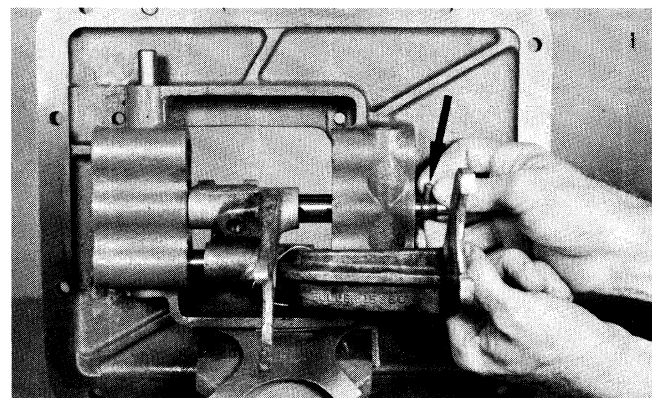

6. Cut the lockwire, turn out the lockscrew and pull the 2nd-3rd speed shift bar from the housing, removing the interlock pin from the neutral notch; remove yoke.

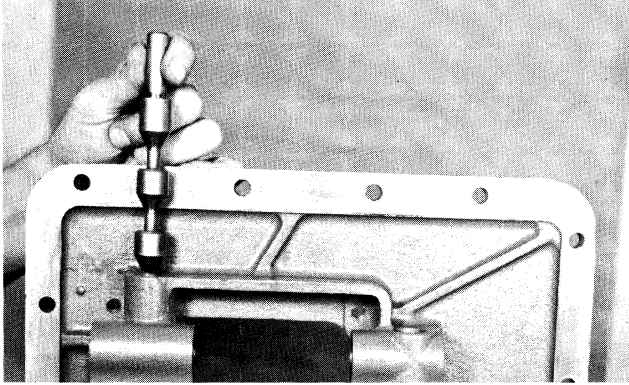

7. Remove the actuating plunger from the housing.

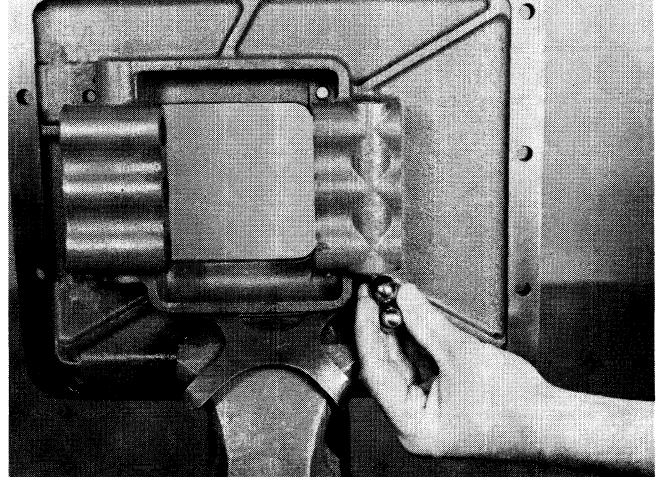

9. Remove the two interlock balls from the web of the housing.

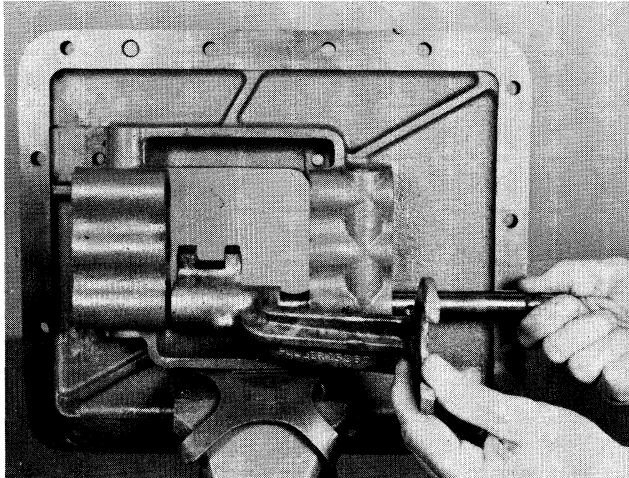

8. Cut the lockwire, turn out the lockscrew and pull the 4th-5th speed bar from the housing, removing the yoke.



## **II. COMPANION FLANGE AND CLUTCH HOUSING**

### **A. Removal of the Companion Flange**

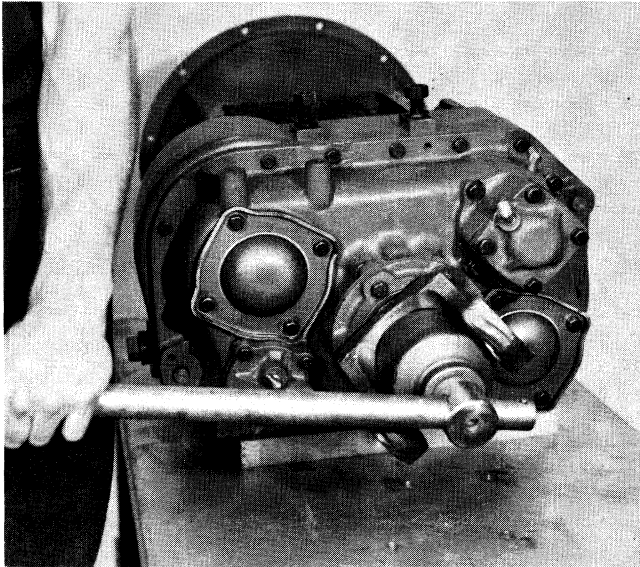

1. Lock the transmission in two speeds and turn the nut from the tailshaft.

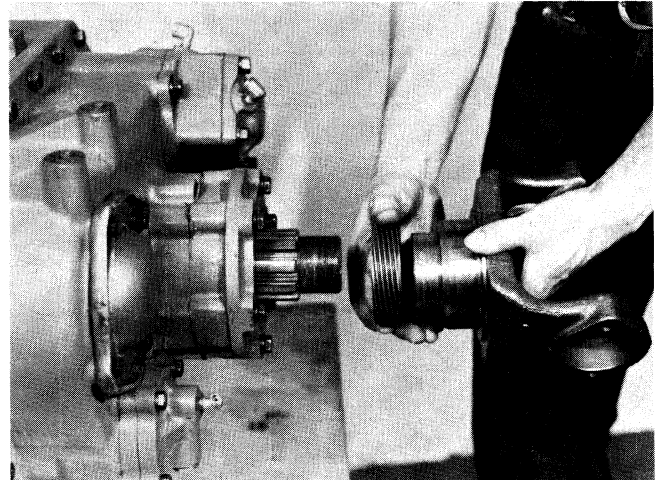

3. Remove the speedometer drive gear or replacement spacer from the companion flange or yoke.

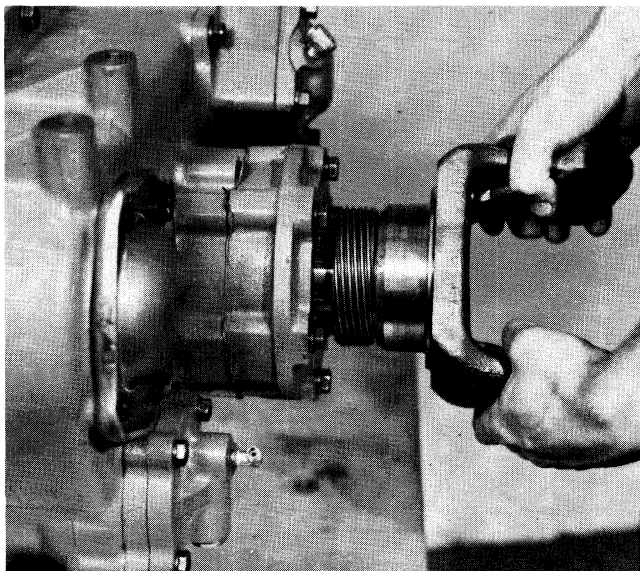

2. Pull the companion flange or yoke from the splines of the tailshaft.

### B. Removal of the Clutch Housing

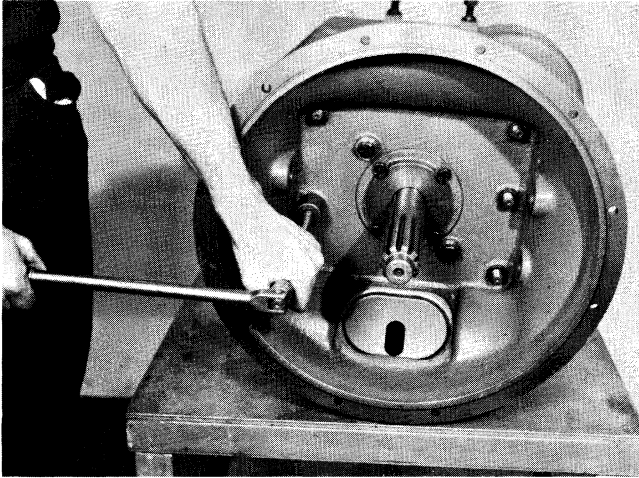

1. Remove the clutch release mechanism or upshift clutch brake assembly and turn out the six nuts and two bolts which attach the clutch housing to the case.

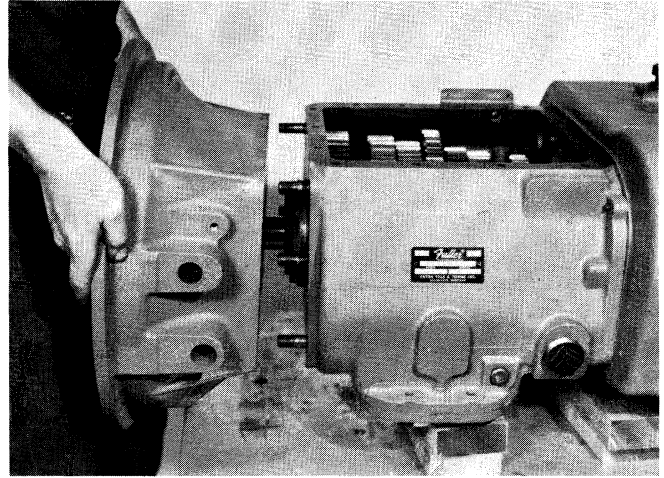

2. Jar the housing to break the gasket seal and pull from the studs and transmission case.

### III. AUXILIARY REAR HOUSING ASSEMBLY

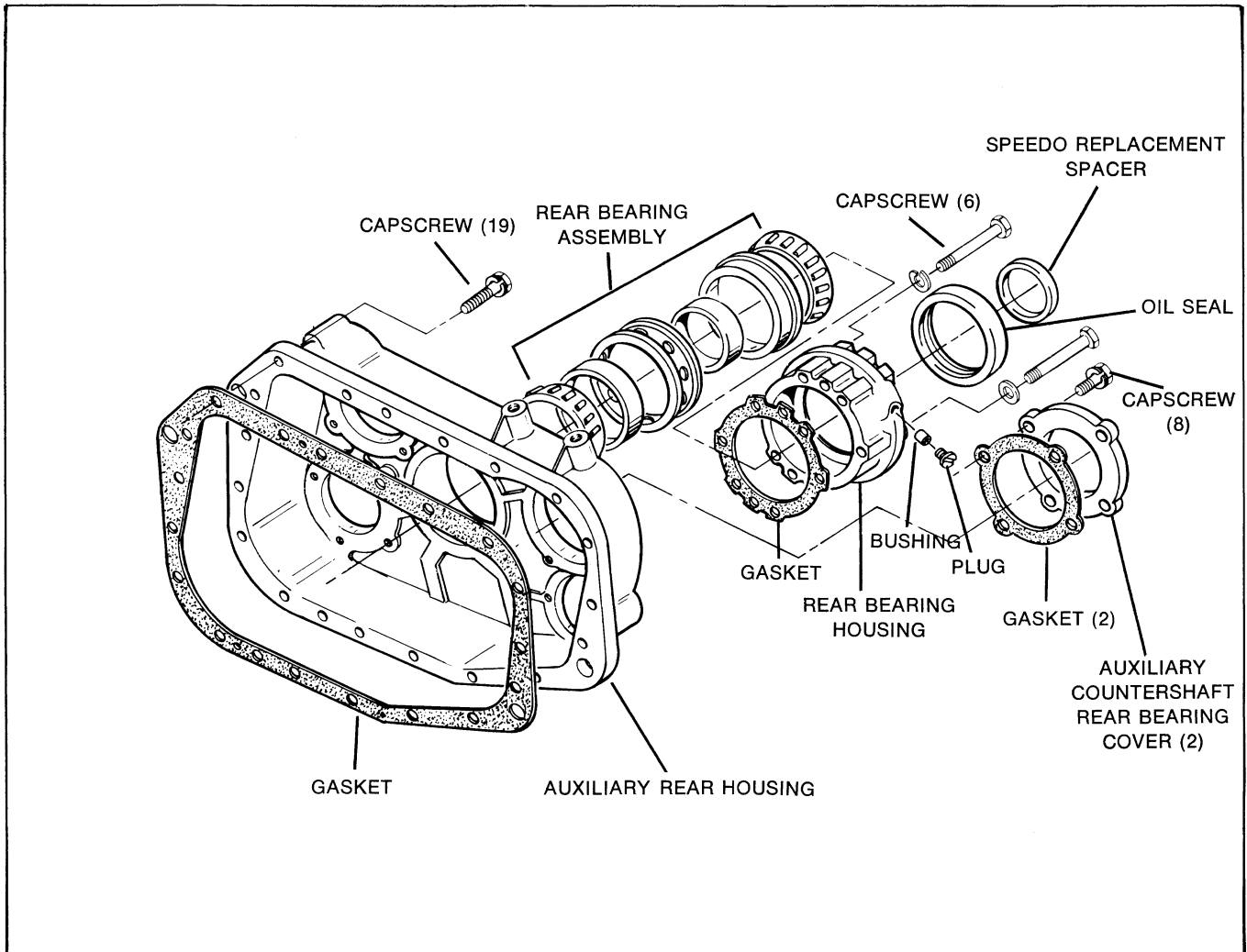

#### A. Removal of the Rear Housing Assembly

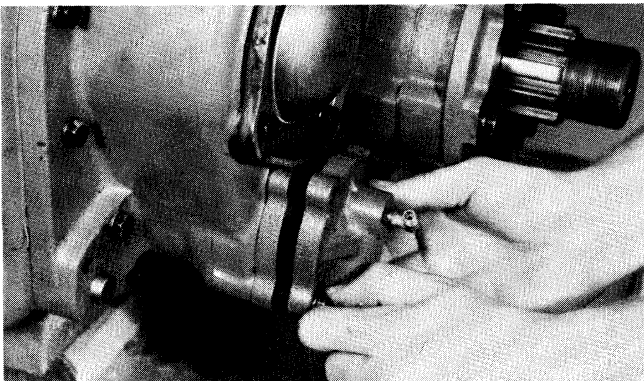

1. Turn out the four cap screws and remove the cover from the intermediate shift cylinder.

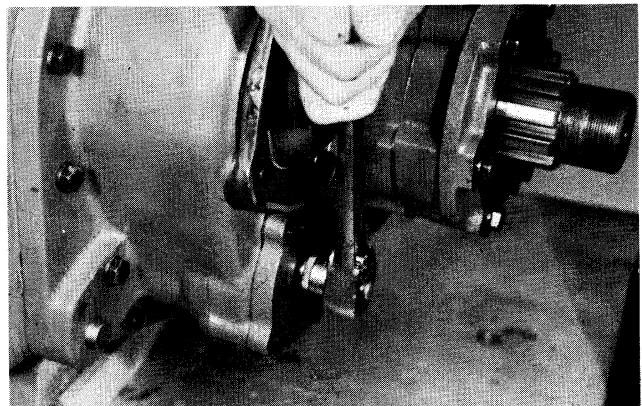

2. Remove the locknut from the shaft in the cylinder.

## DISASSEMBLY – AUXILIARY REAR HOUSING



3. Pull evenly to the rear and remove the cylinder housing from the bore in the auxiliary housing.

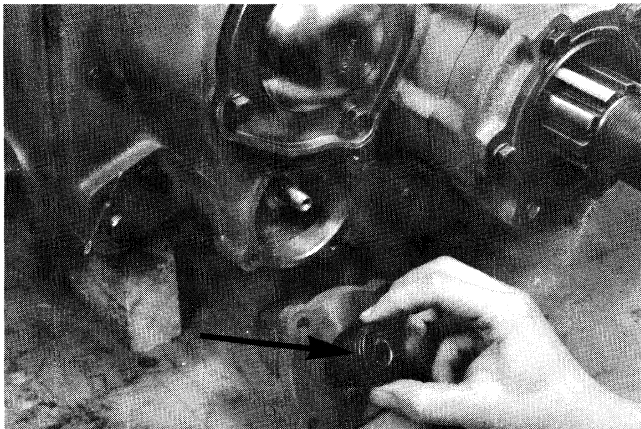

4. Remove the piston from the cylinder housing and, if necessary, remove the O-ring from the outer diameter of the piston.



5. If necessary, remove the O-rings from the bore in the cylinder housing and the shaft.

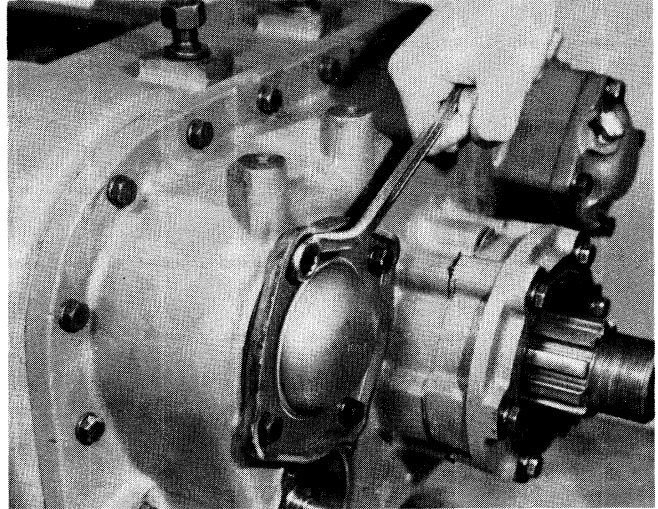

6. Turn out the capscrews and remove the two rear counter-shaft bearing covers.

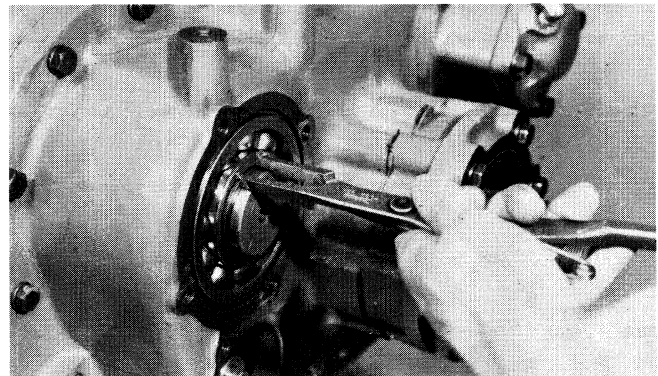

7. Remove the snap ring from the rear of both counter-shafts.

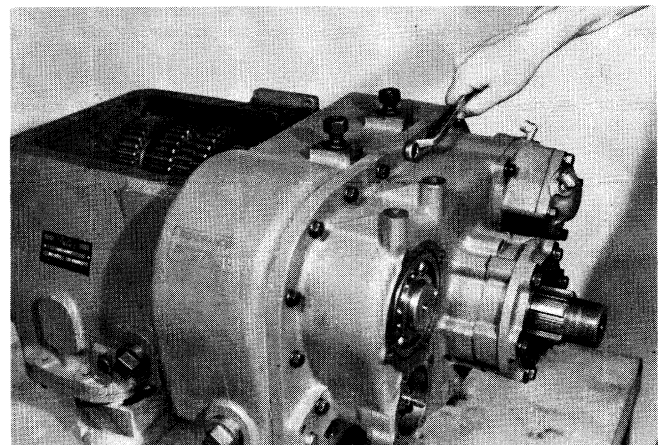

8. Turn out the 19 capscrews which attach the rear housing to the intermediate case. Re-insert one capscrew near both dowel pin locations and turn in just far enough to catch two or three threads.



## DISASSEMBLY – AUXILIARY REAR HOUSING

### A. Removal of the Rear Housing Assembly – Continued

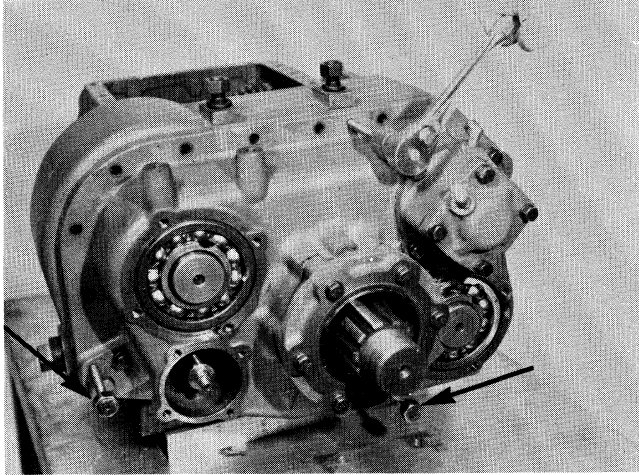

9. Insert three puller screws and move the rear housing approximately  $\frac{1}{4}$ " to the rear.

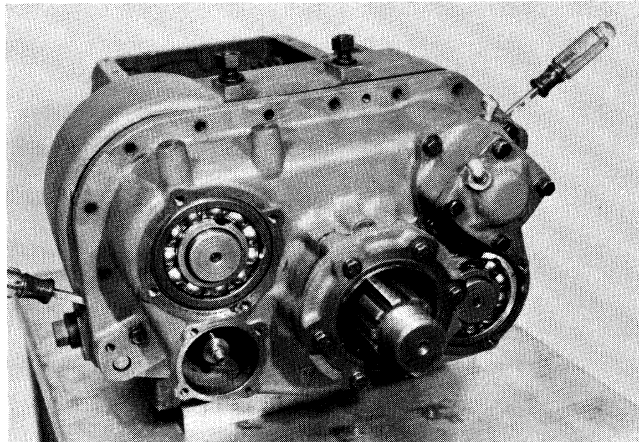

10. Insert flat stock, such as flat-bladed screwdrivers, between the auxiliary and intermediate housings.

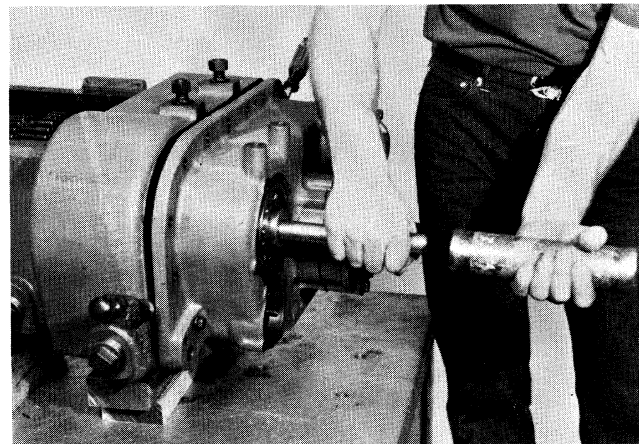

11. Use a soft bar and mallet against the rear of both countershafts to move them as far forward as possible. This will move the bearings to the rear on the shafts.

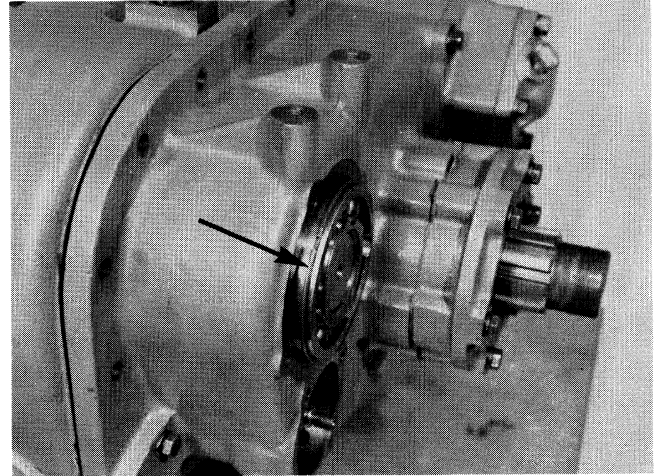

12. Remove the flat stock and puller screws. Move the rear housing to its original position against the intermediate housing by turning in evenly the two remaining cap-screws. This will expose the two rear bearing snap rings.

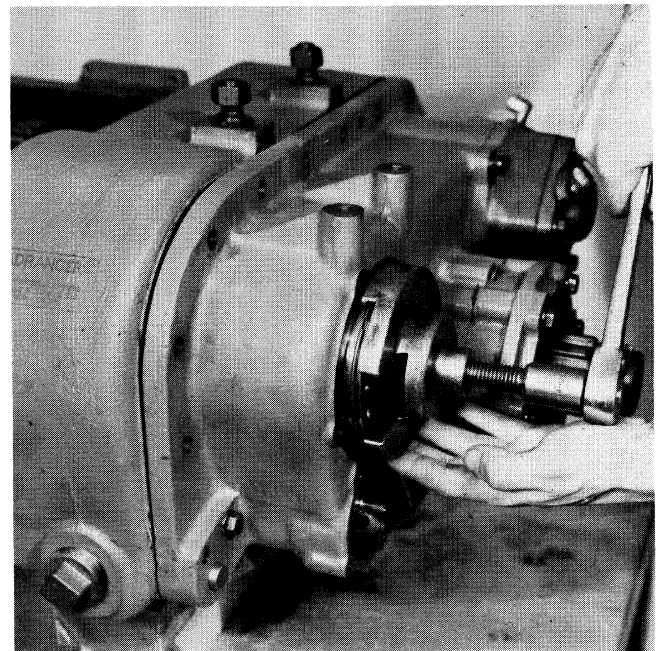

13. Attach a bearing puller to each snap ring and remove both rear bearings from the countershafts.

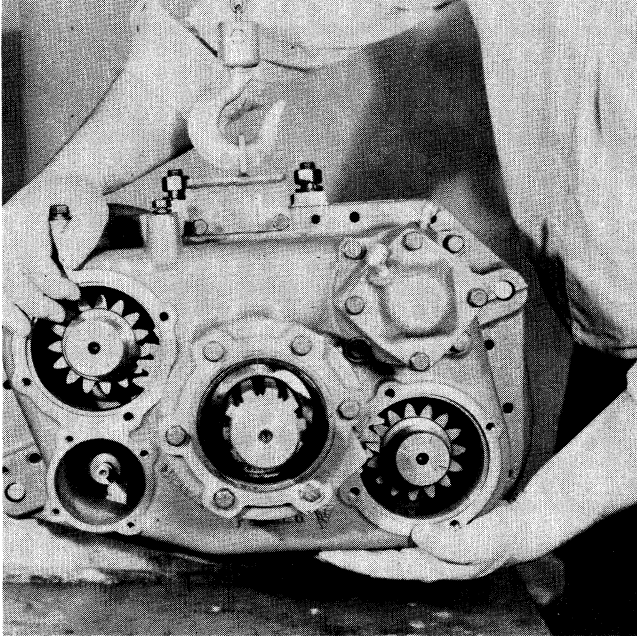

14. Remove the two remaining capscrews. Attach a chain hoist to the rear housing and move the assembly straight to the rear and away from the intermediate housing, taking care not to damage the oil trough located at the top rear of the intermediate housing. Mount the assembly in a vise in the upright position.

## DISASSEMBLY – AUXILIARY REAR HOUSING

### B. Removal and Disassembly of the Auxiliary Shift Cylinder

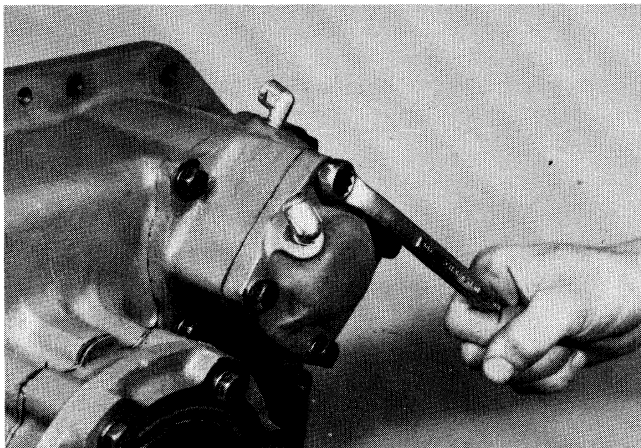
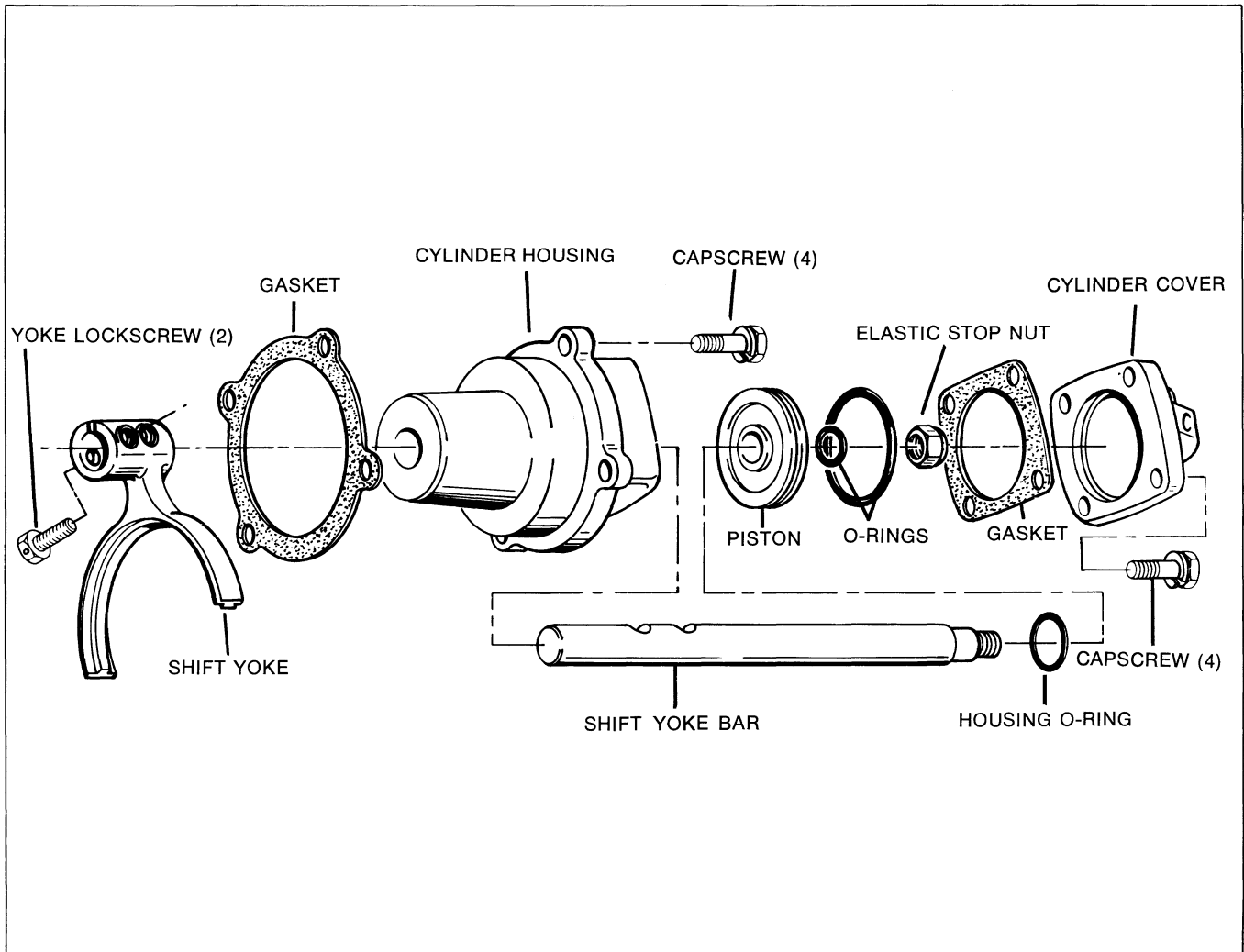

1. Turn out the four cap screws and remove the cover from the shift cylinder.

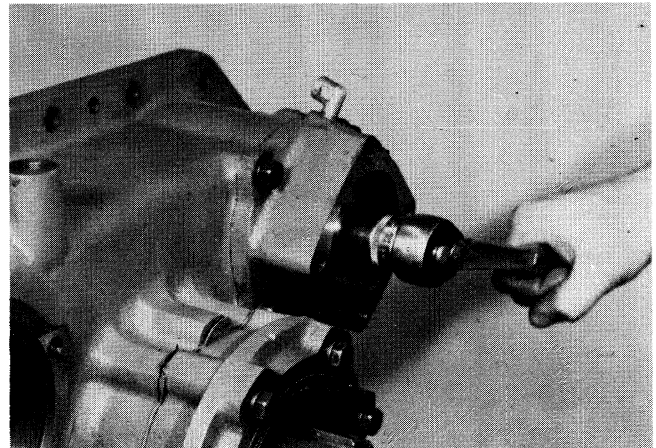

2. Remove the locknut from the shifting shaft in the cylinder.

## DISASSEMBLY – AUXILIARY REAR HOUSING

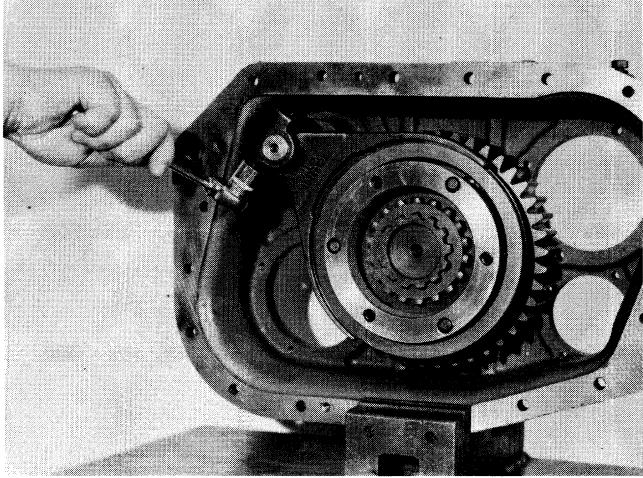

3. Cut the lockwire and turn out the two yoke lockscrews.

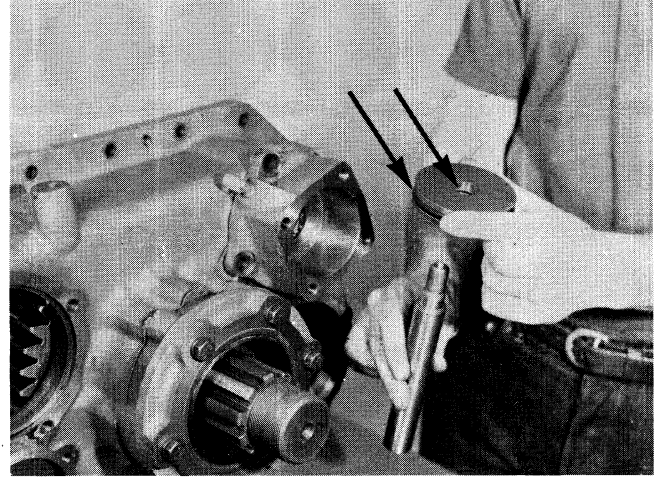

5. Remove the piston from the shaft and remove the O-rings on the inner and outer diameters of the piston.

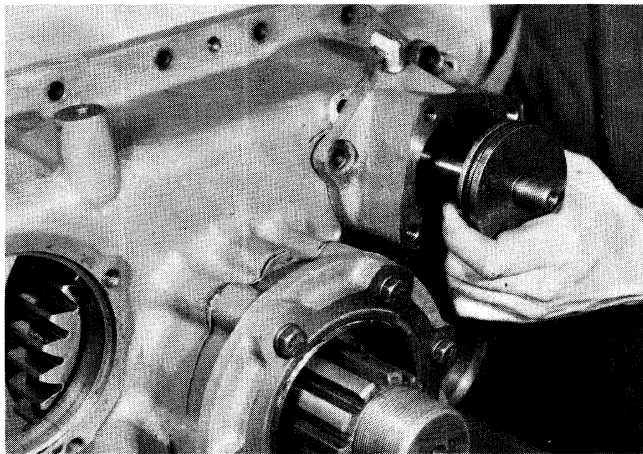

4. Push the shifting shaft and piston to the rear and remove from the cylinder housing. At the same time remove shifting yoke from sliding clutch gear.

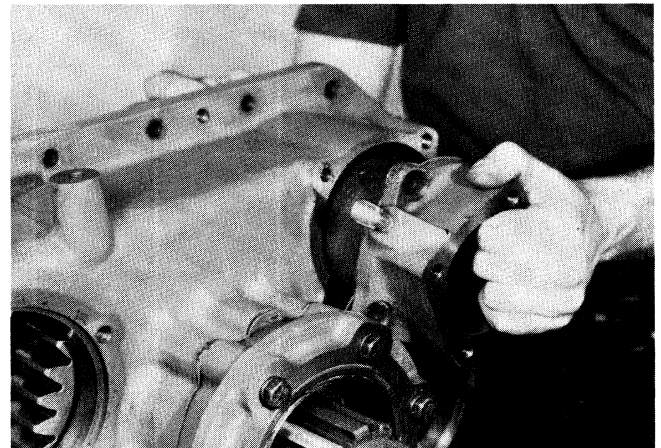

6. Turn out the four capscrews and remove the cylinder housing from the bore in the auxiliary rear housing. Remove the O-ring from the bore in the cylinder housing. Remove synchronizer assembly from splines of tailshaft.



## DISASSEMBLY – AUXILIARY REAR HOUSING

### C. Disassembly of the Synchronizer Assembly

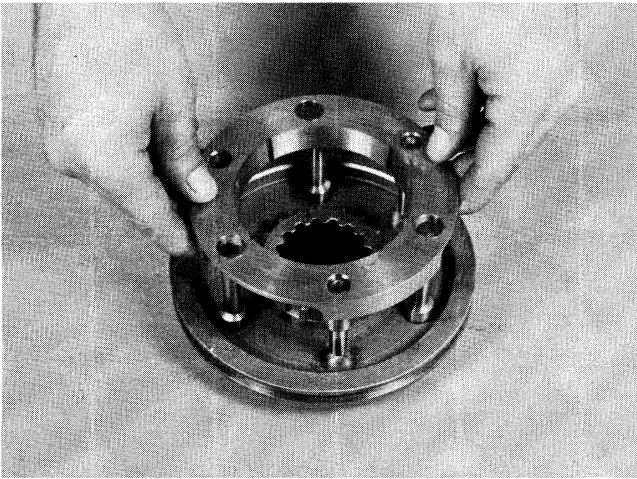
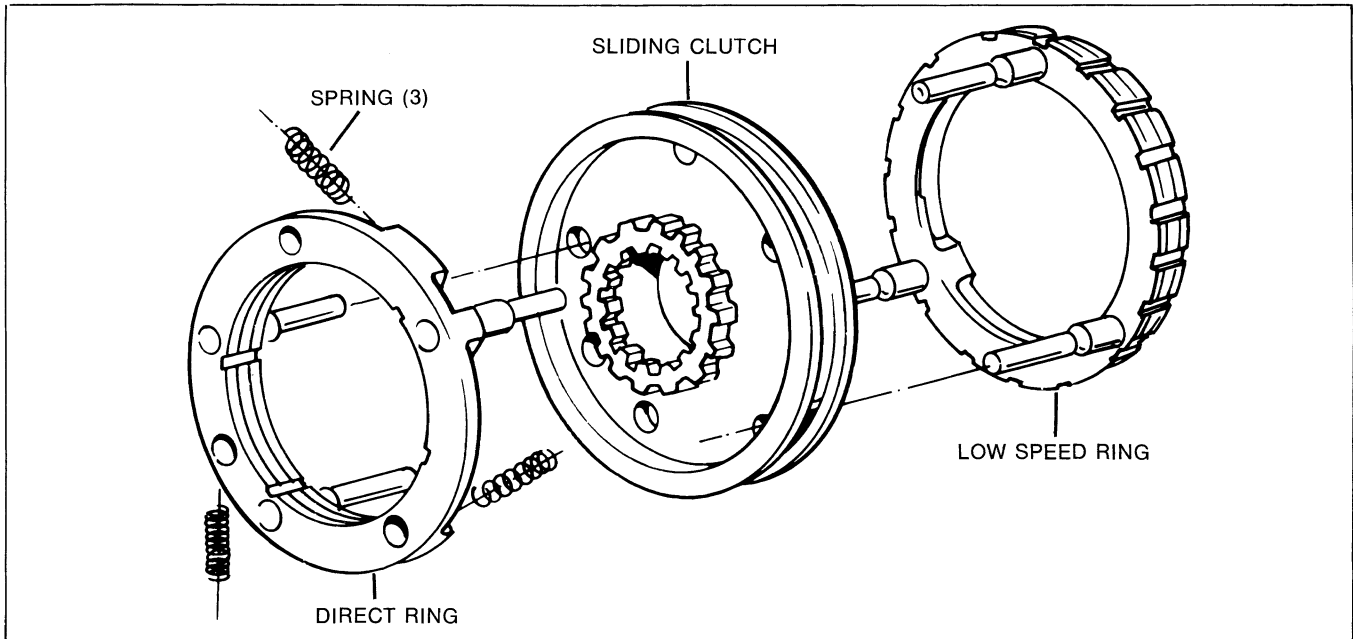

1. Pull the direct synchronizer from the blocker pins of the low speed synchronizer. Place a cloth over rings during removal as the three springs in the direct ring will be released at the pin locations.

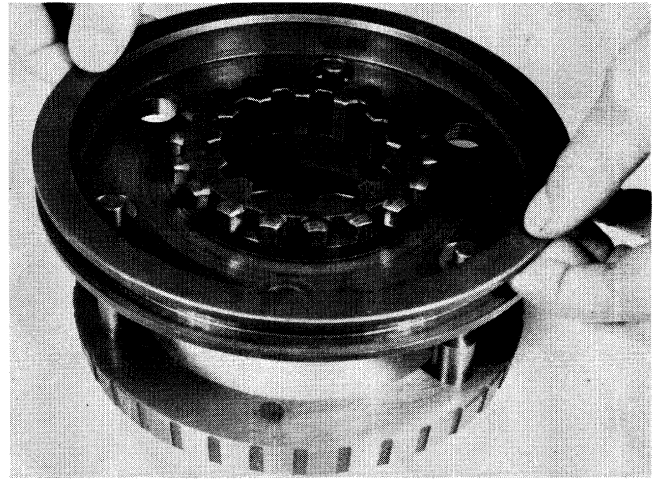

2. Remove the sliding clutch from the low speed synchronizer.

D. Removal and Disassembly of the Tailshaft and Low Speed Gear Assembly

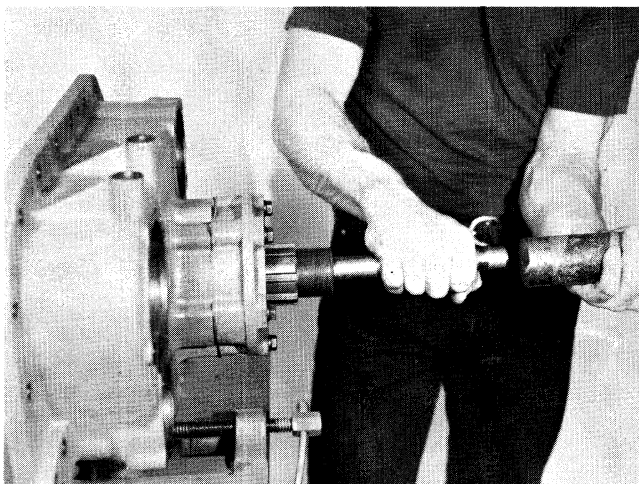
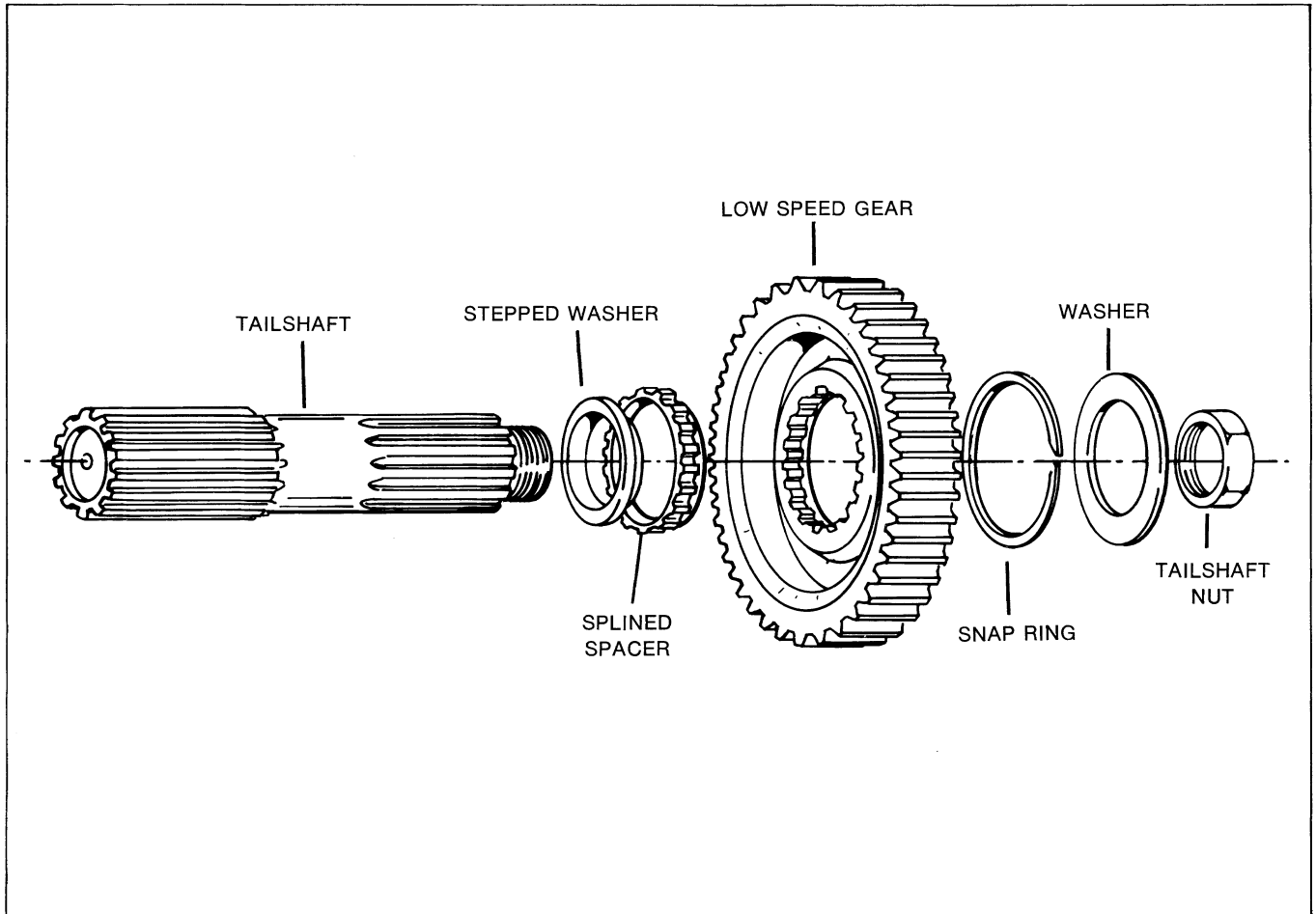

1. Use a soft bar and mallet against the rear of the tailshaft to move the assembly forward and from the rear bearing.

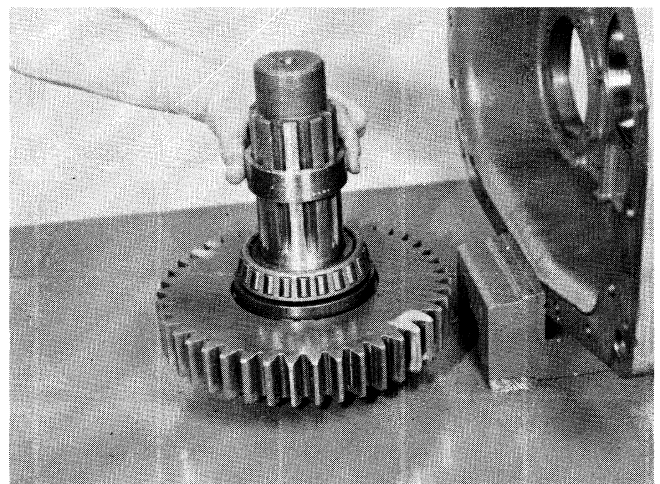

2. Remove the bearing inner sleeve from the shaft.

## DISASSEMBLY – AUXILIARY REAR HOUSING

### D. Removal and Disassembly of the Tailshaft and Low Speed Gear Assembly – Continued

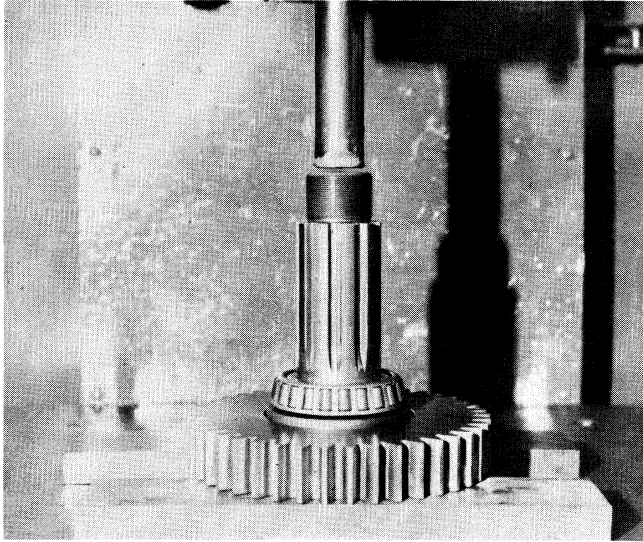

3. Use the low speed gear as a base to press the bearing from the shaft and to free the gear and rear washer.

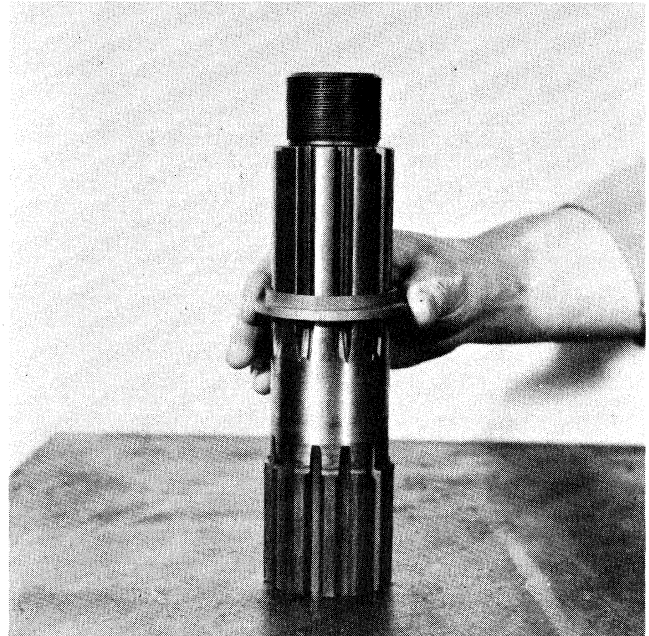

5. Remove the stepped washer from the shaft.

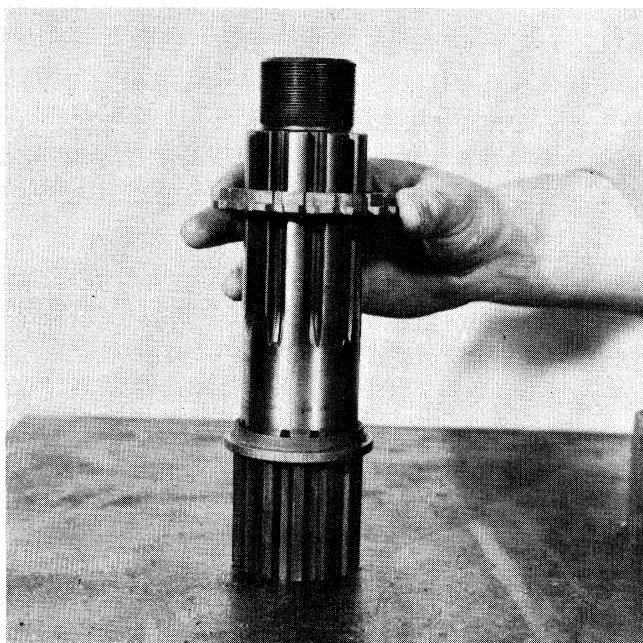

4. Remove the splined washer from the shaft.

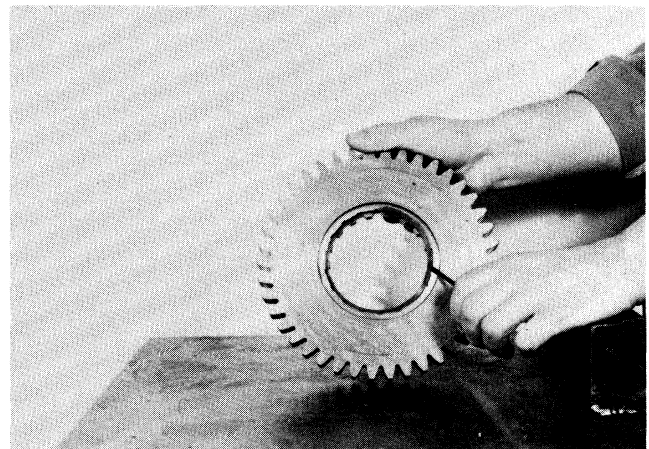

6. If necessary, remove the snap ring from the inner diameter of the low speed gear.

## DISASSEMBLY – AUXILIARY REAR HOUSING

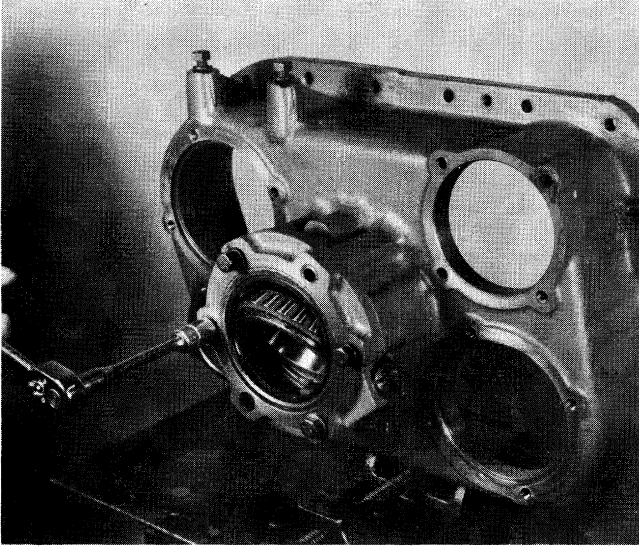

7. Turn out the cap screws and remove the rear bearing cover. If necessary, remove the oil seal from the cover.

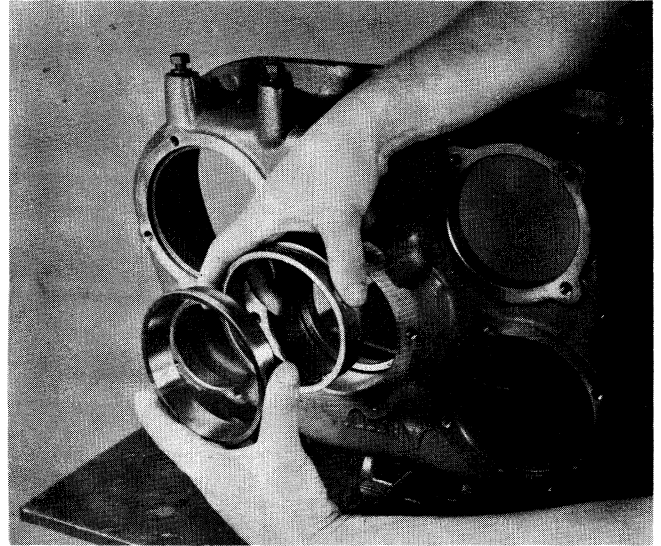

9. Remove the two bearing cups and outer spacer from the housing bore.

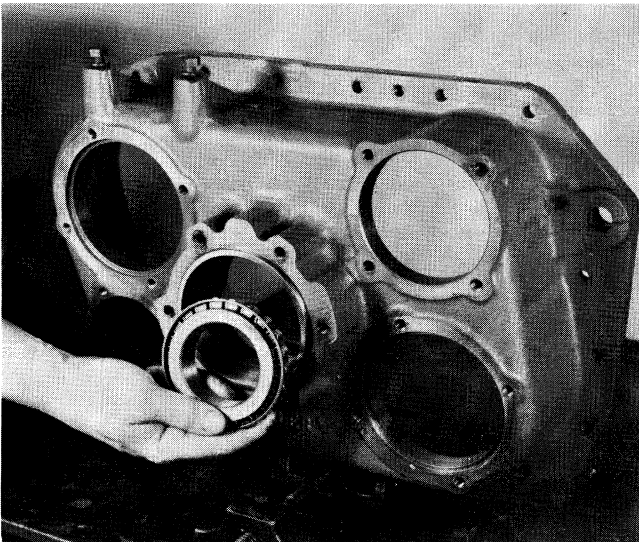

8. Remove the bearing rear cone.



## IV. AUXILIARY INTERMEDIATE HOUSING

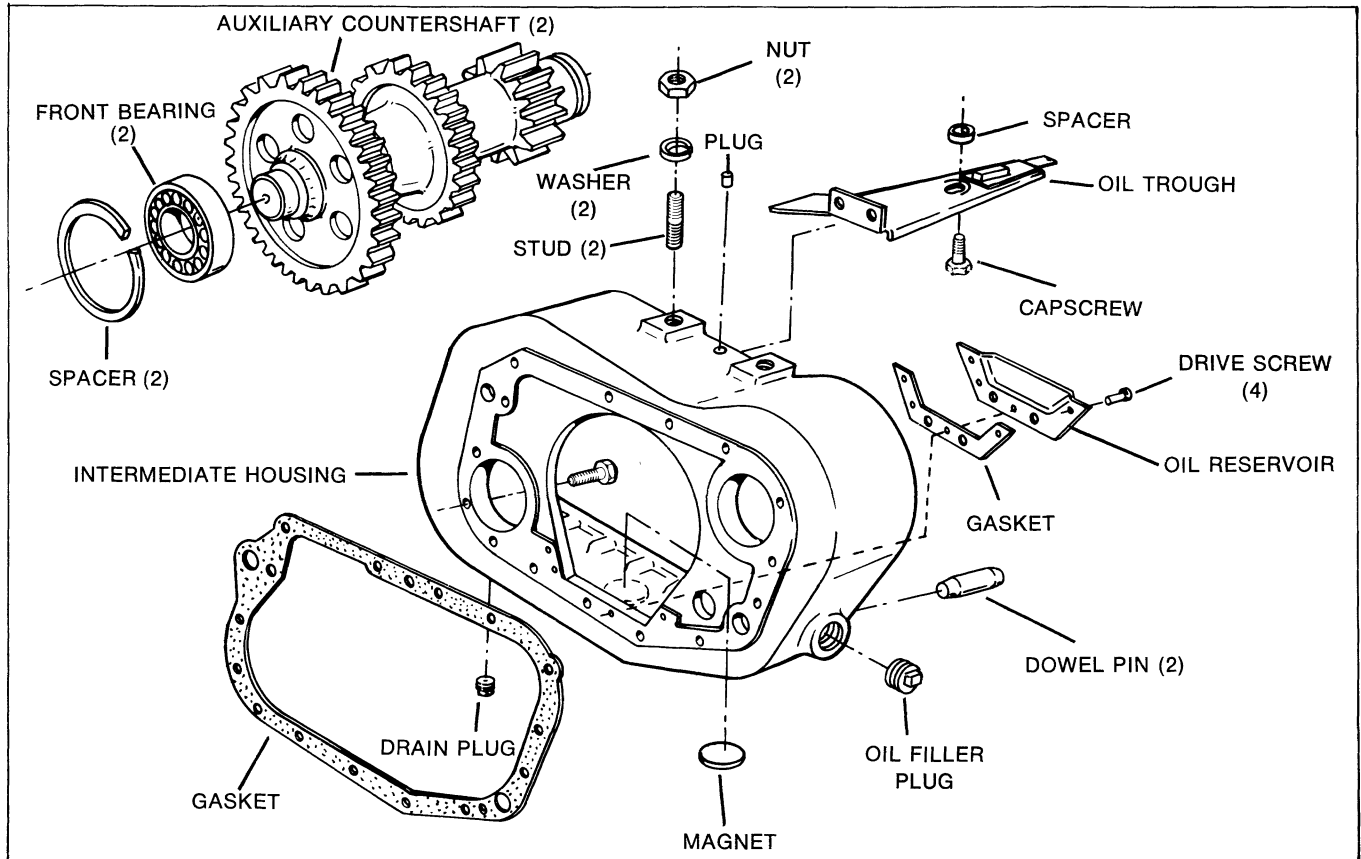

### A. Removal and Disassembly of the Intermediate Housing and Gearing

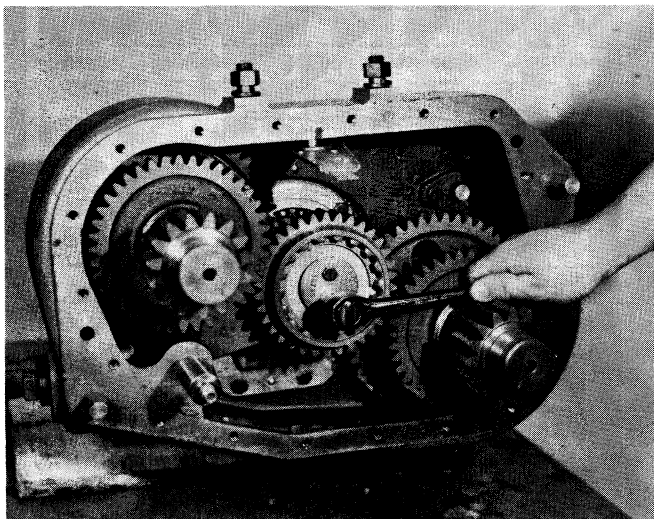

1. Cut the lockwire, turn out the two cap screws and remove the plate from the rear of the mainshaft.

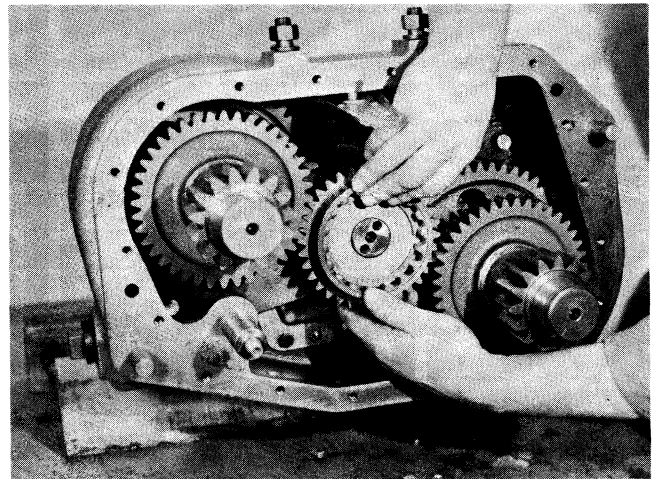

2. Remove the intermediate drive gear from the shaft and if necessary, remove the two snap rings and plate from the inner diameter of the intermediate drive gear.

## DISASSEMBLY – AUXILIARY INTERMEDIATE HOUSING

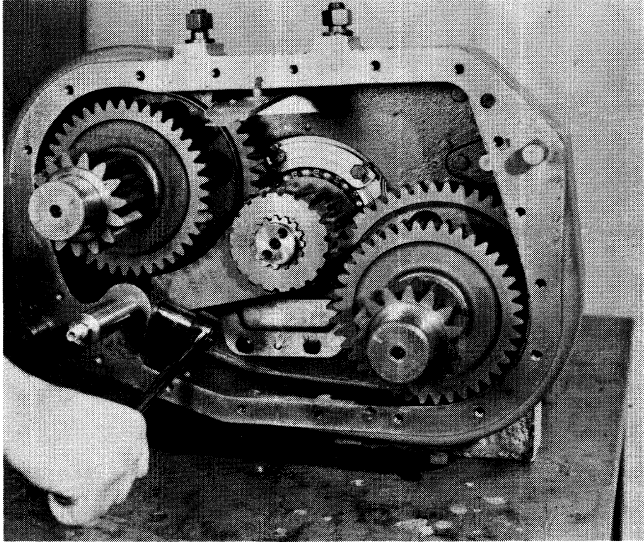

3. Cut the lockwire and turn out the lockscrew from the intermediate shift yoke.

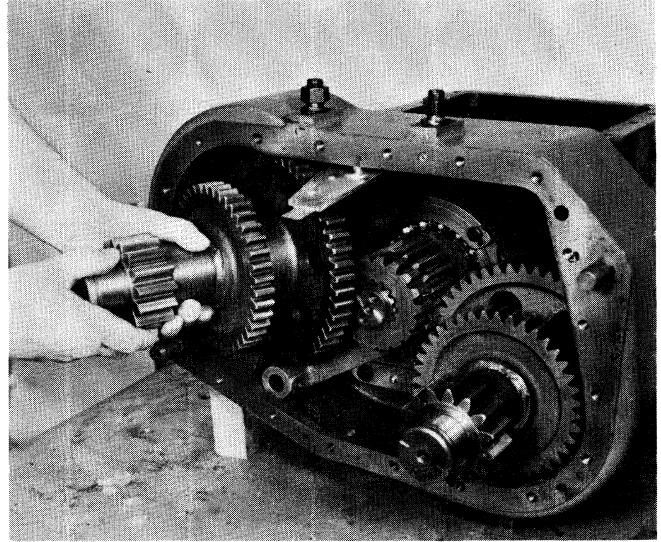

5. Remove the left countershaft from the housing, using caution to avoid damage to the oil trough.

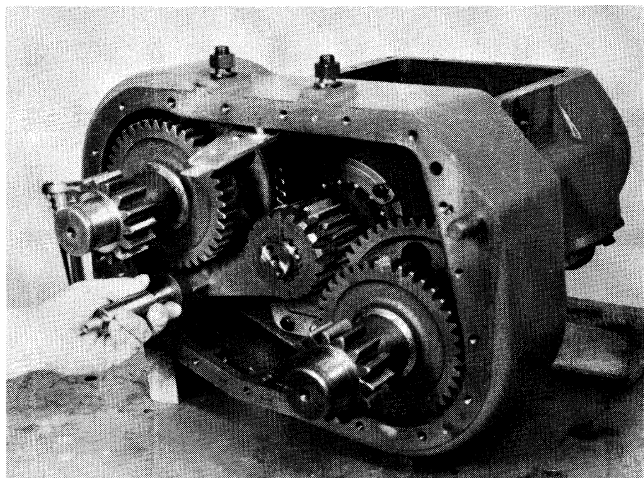

4. Remove the intermediate shift shaft from the housing.

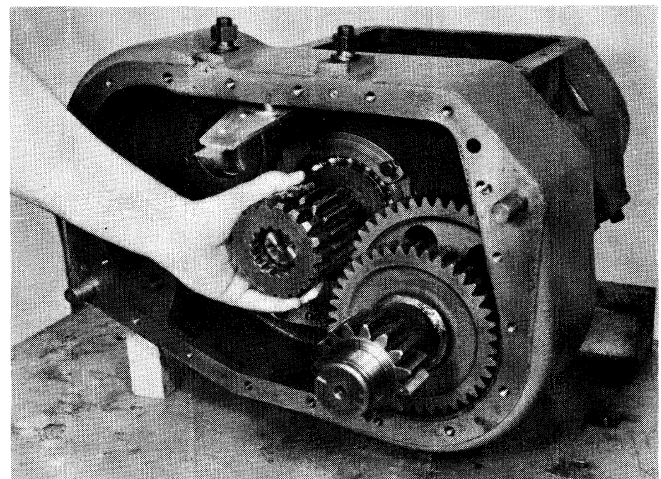

6. Remove the shift yoke and pull the auxiliary drive gear and sliding clutch assembly from the splines of the main shaft. Both sections must align with the splines for removal.

## DISASSEMBLY – AUXILIARY INTERMEDIATE HOUSING

### A. Removal and Disassembly of the Intermediate Housing and Gearing – Continued

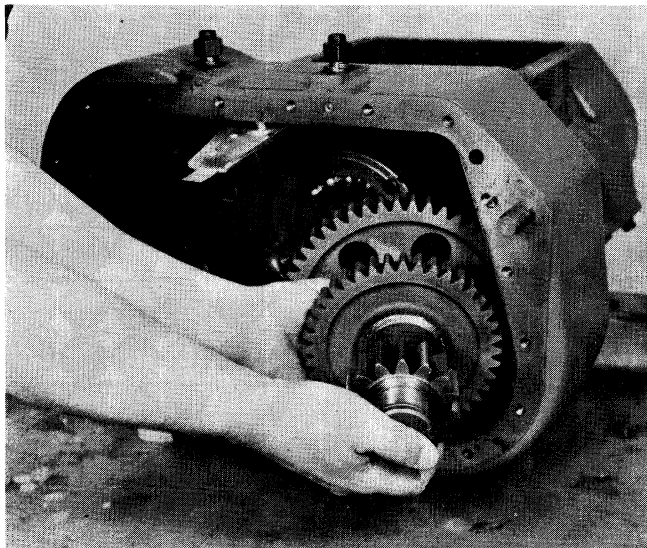

7. Pull the right auxiliary countershaft from the intermediate case.

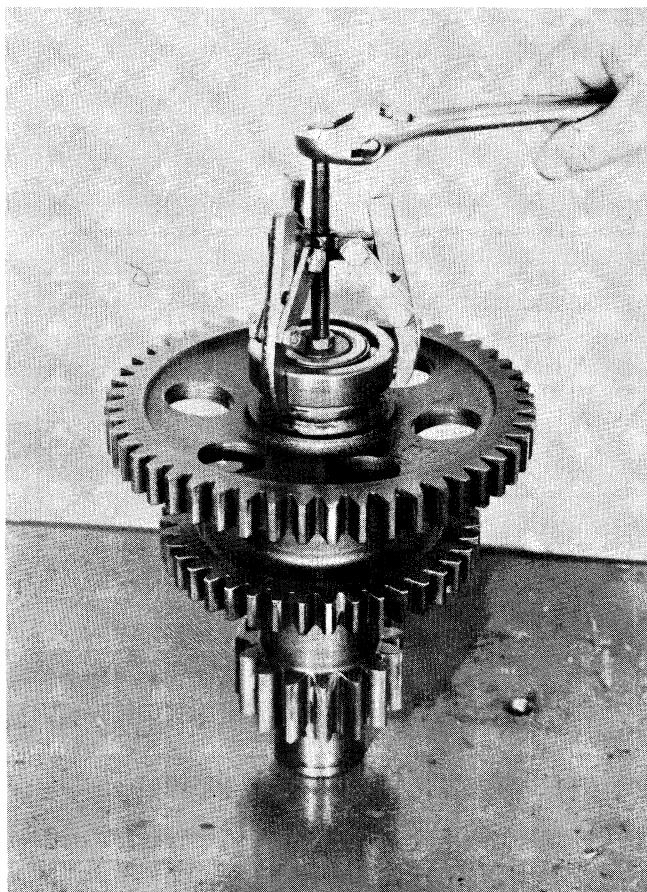

8. Pull the front bearings from the countershafts if necessary.

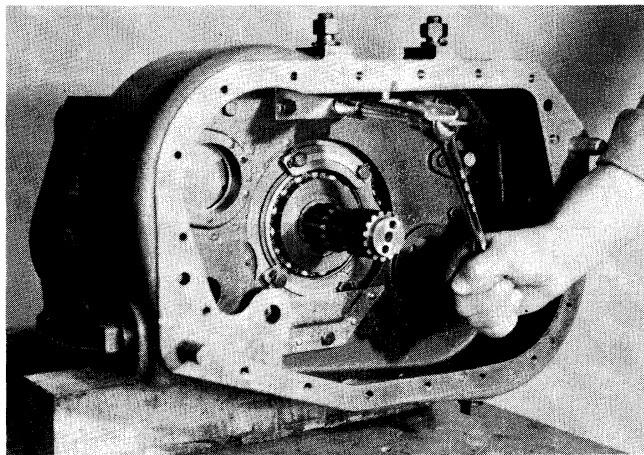

9. Turn out the three cap screws and remove the oil trough from the intermediate housing.

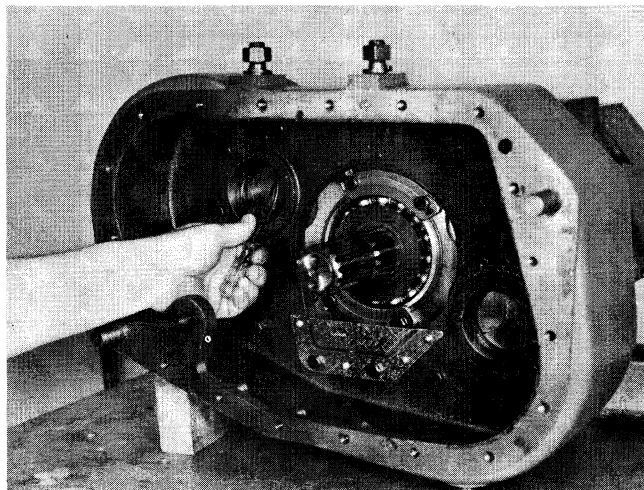

10. Remove the snap ring spacers from the front countershaft bearing bores.

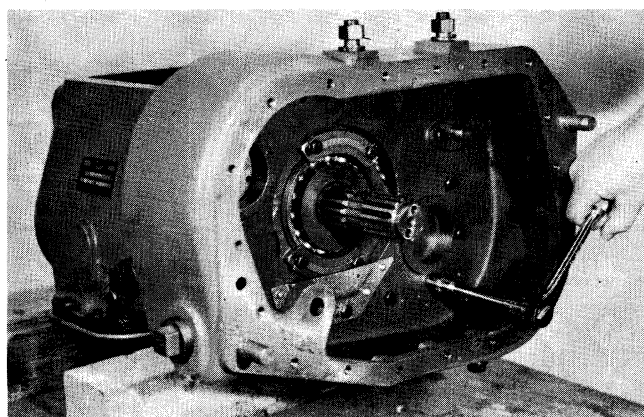

11. Turn out the 13 remaining cap screws and remove the intermediate housing from the transmission.



**B. Disassembly of the Auxiliary Drive Gear/Clutch Gear Assembly**

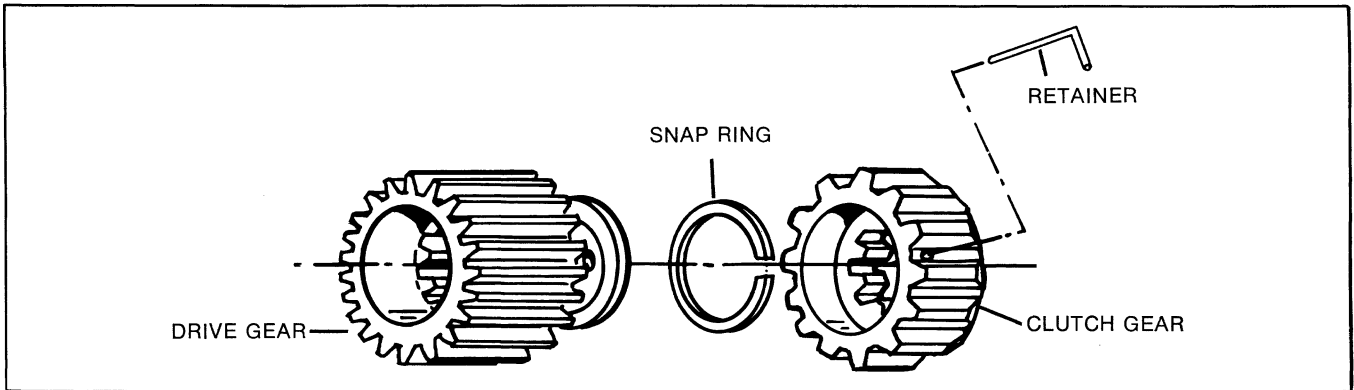

NOTE: Assembly should be disassembled only if absolutely necessary. The retaining pin is not reusable and must be replaced.

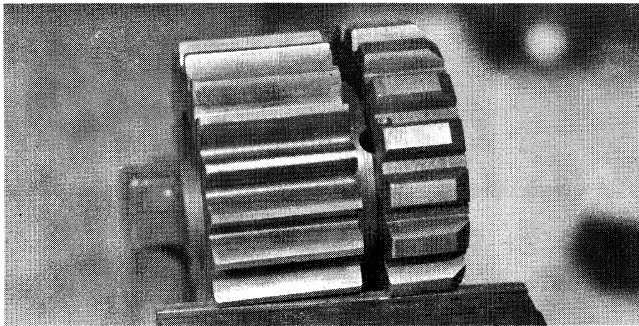

1. Align one of the holes in the small diameter of the drive gear with the retaining pin of the clutch gear and mount the assembly in a vise.

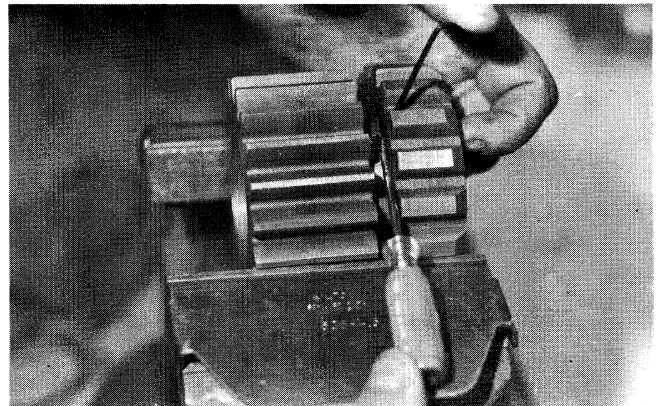

3. Position the snap ring in the clutch gear so that the retaining pin hole is approximately  $\frac{1}{2}$ " from the open section of the snap ring. Insert a small Allen wrench or equivalent into the retaining pin hole and force down so that the snap ring is forced out of the groove. Insert a small screwdriver between the snap ring and clutch gear and pry the snap ring from the groove.

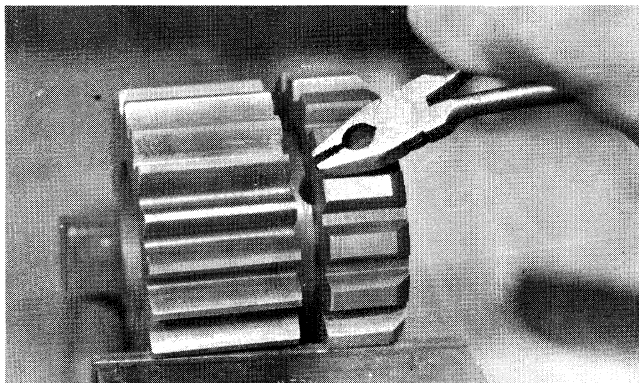

2. Remove the bended end of the pin and drive the pin down and through the hole in the drive gear.

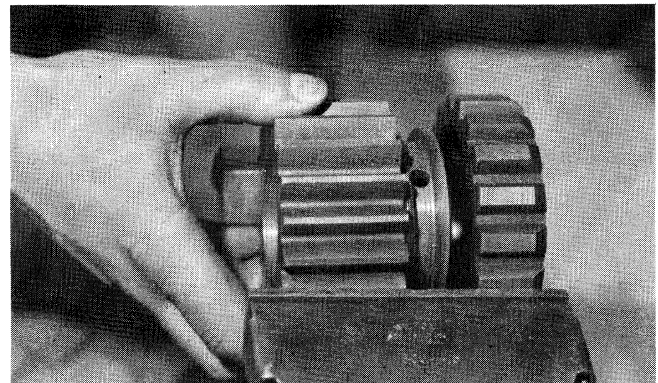

4. Remove the drive gear from the clutch gear and, if necessary, remove the snap ring from the drive gear.

## V. FRONT SECTION

### A. Removal of the Right Countershaft Bearings

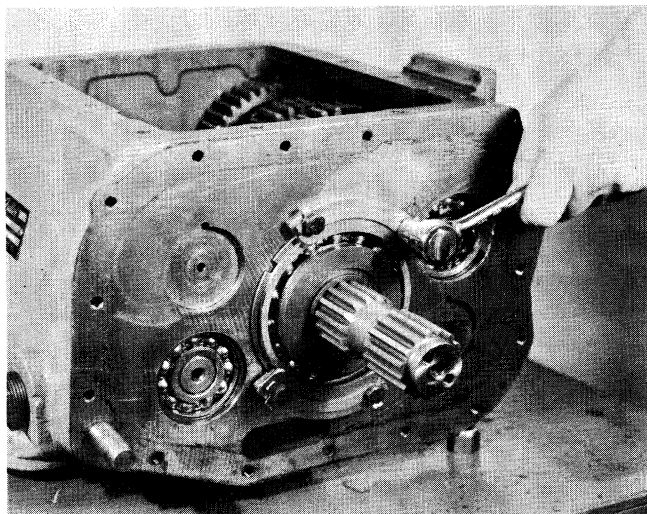

1. Loosen, but do not remove the two mainshaft rear bearing retainers.

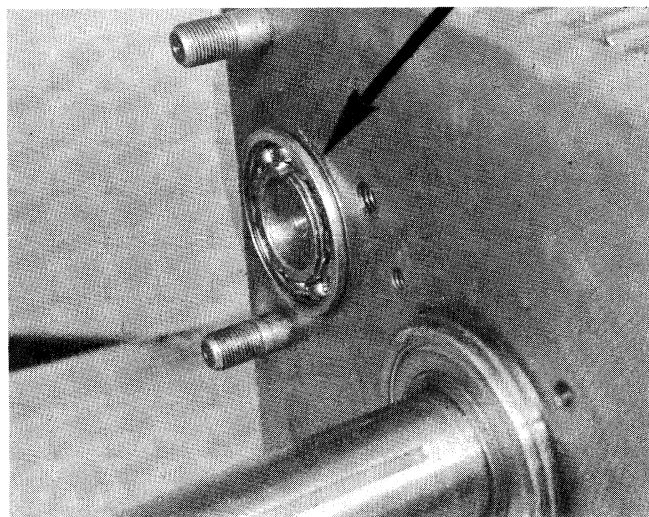

2. Use a soft bar and mallet against the rear of the right countershaft to drive the assembly as far forward as possible, exposing the snap ring groove in the front bearing.



3. Remove the snap ring from the rear countershaft bearing bore and install in the front bearing snap ring groove.

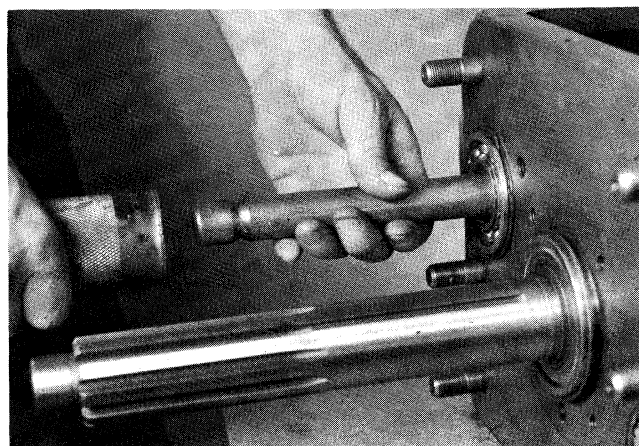

4. Use a soft bar and mallet to move the assembly to the rear as far as possible, partially unseating the front bearing from the shaft.

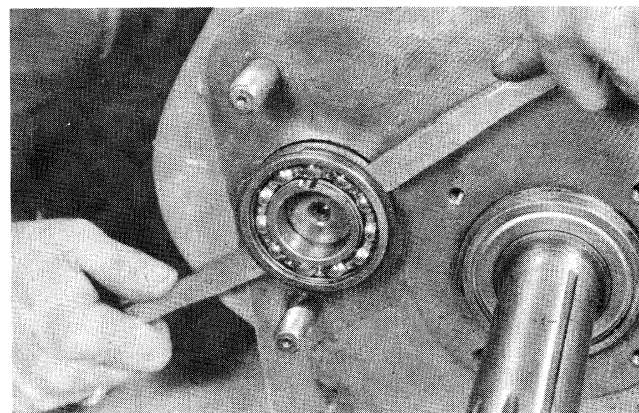

5. Move the countershaft forward and remove the front bearing with a puller or pry bars.

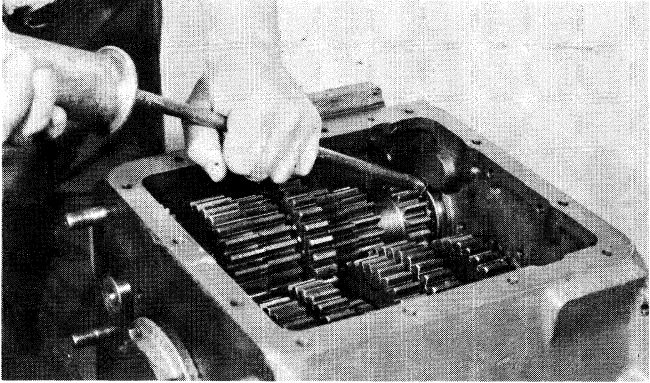

6. Use a blunt punch or equivalent from inside the case and tap the rear bearing back approximately  $\frac{1}{4}$ " on the shaft. Tap on the outer race to avoid damaging the bearing.

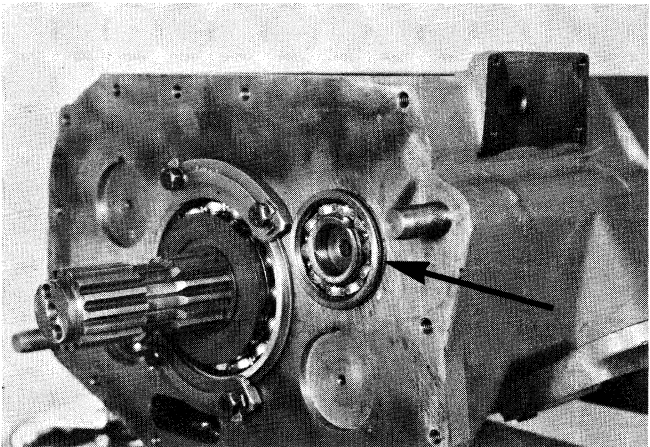

7. Use a soft bar and a mallet to drive the countershaft to the rear, exposing the snap ring groove in the rear bearing.

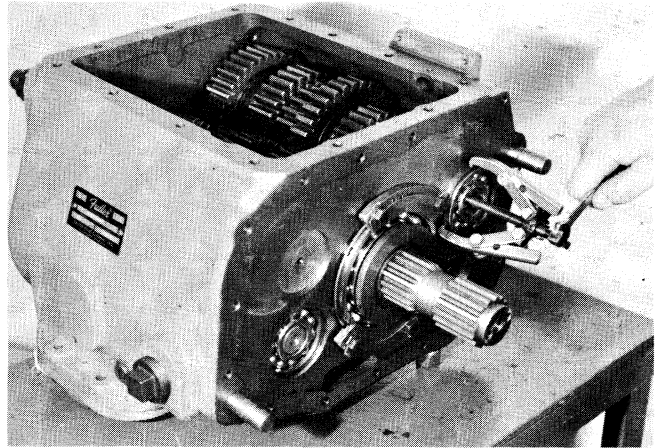

8. Remove the snap ring from the front bearing and install on the rear bearing. Use a puller or pry bars to remove the rear bearing, and re-tighten the two mainshaft rear bearing retainers.



## DISASSEMBLY – FRONT SECTION

### B. Removal of the Clutch Shaft

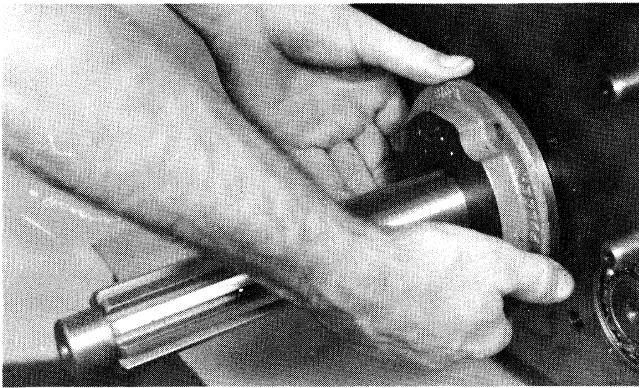
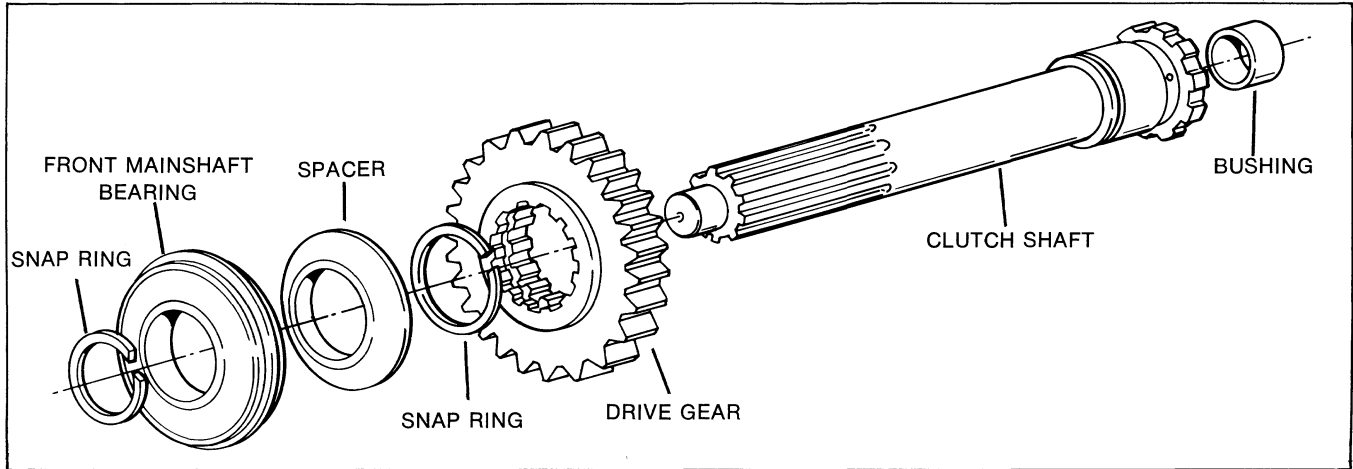

1. Remove the front bearing cover or upshift clutch brake plate.

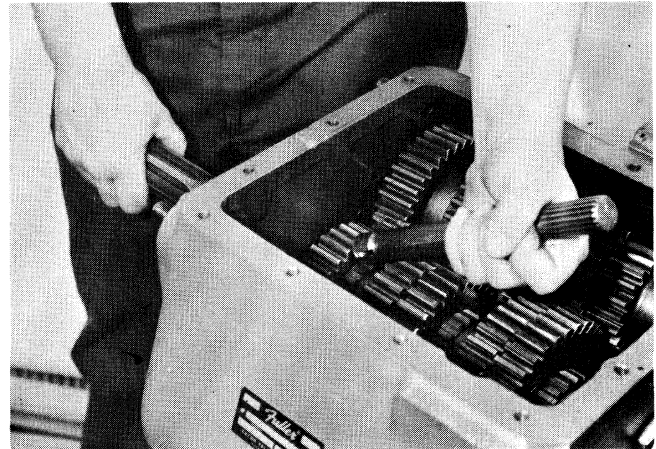

3. Hold the shaft in position and then tap the drive gear forward to unseat the front mainshaft bearing.

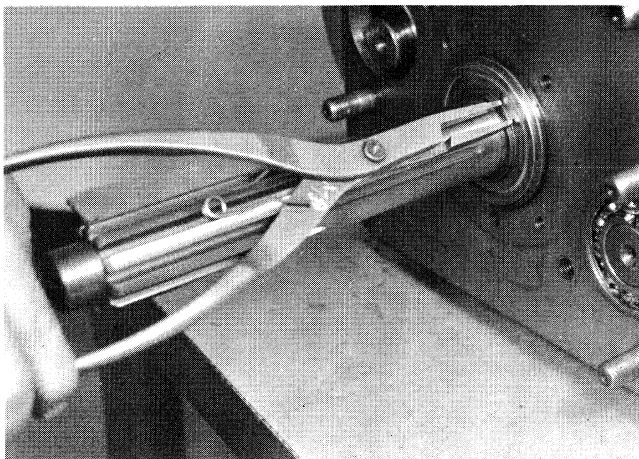

2. Move the drive gear and shaft as far forward as possible and remove the snap ring from the groove in the clutch shaft.

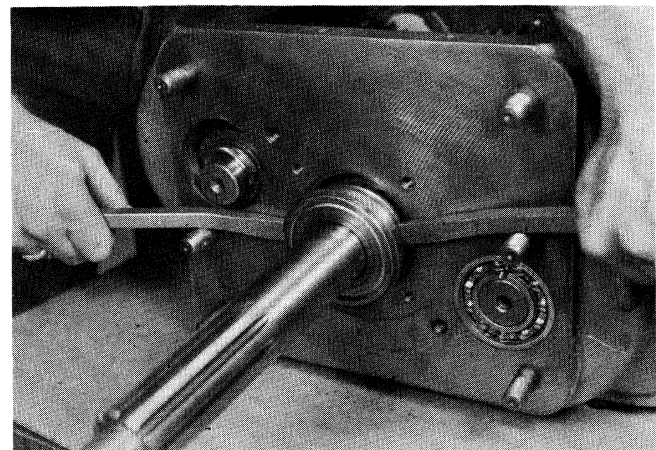

4. Use a puller or pry bars to remove the bearing from the shaft.

## DISASSEMBLY – FRONT SECTION

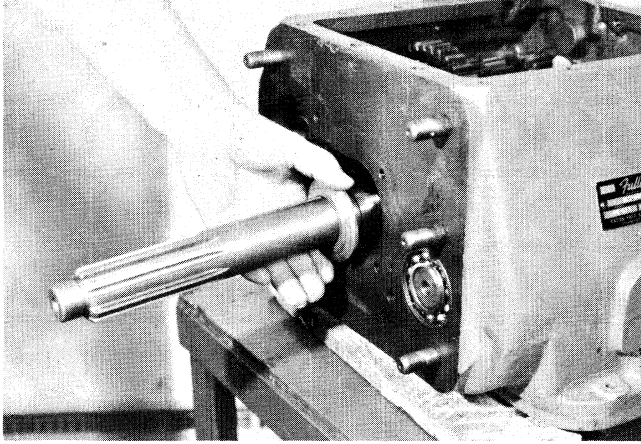

5. Remove the spacer from the shaft.

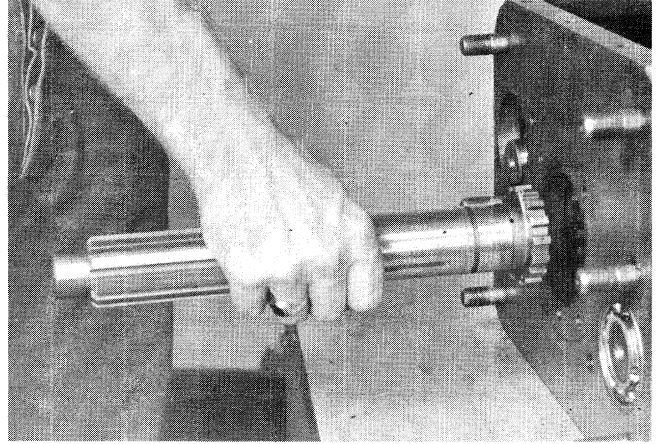

7. Pull the shaft forward and from the splines of the drive gear.

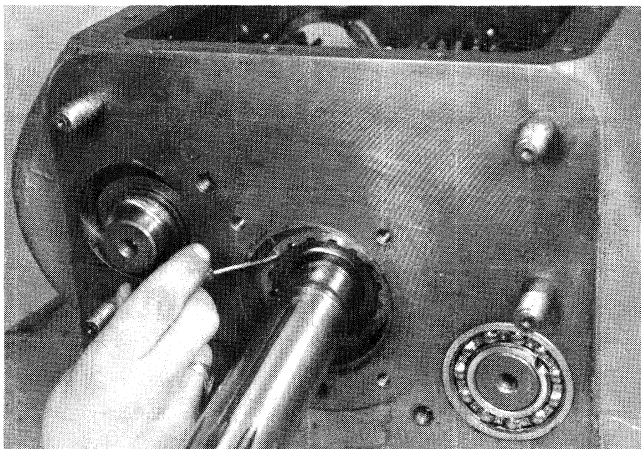

6. Remove the snap ring from the inner diameter of the drive gear.

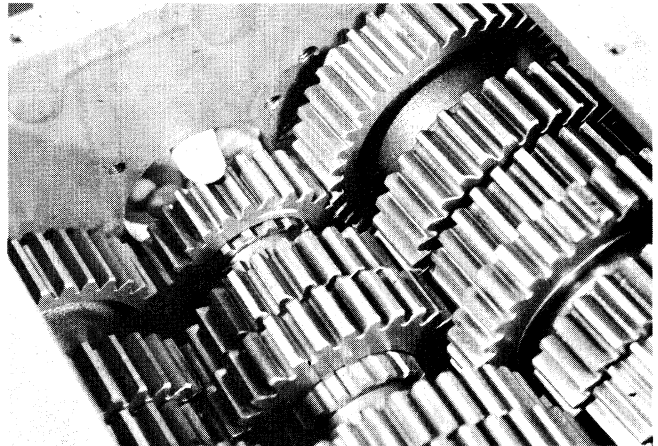

8. Move the drive gear to the rear and against the 4th speed gear, engaging the splines of the sliding clutch.



## DISASSEMBLY – FRONT SECTION

### C. Removal of the Left Reverse Idler Gear

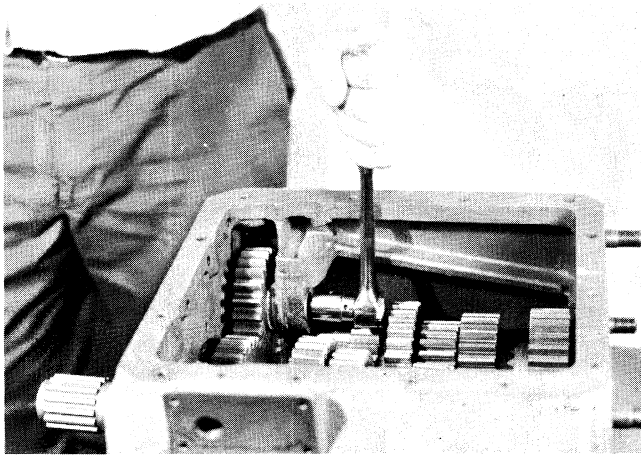
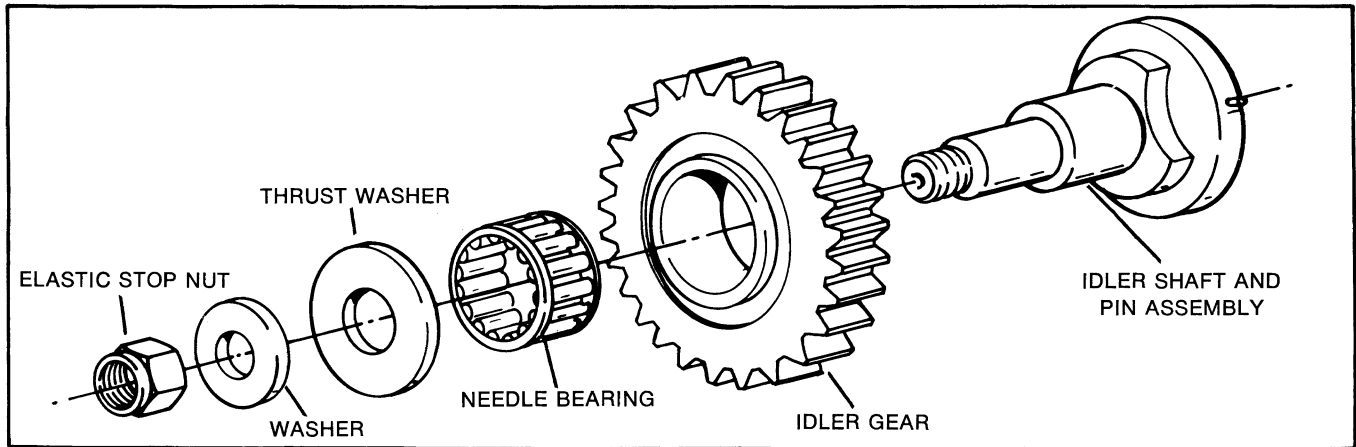

1. Remove the elastic stop nut and washer from the reverse idler shaft.

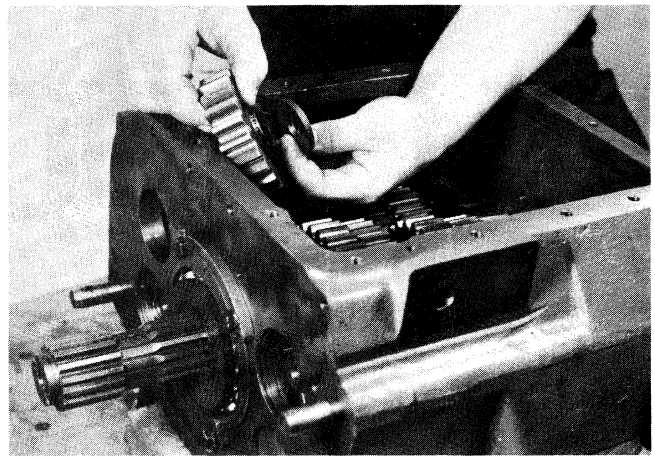

3. Remove the thrust washer and gear from the case.

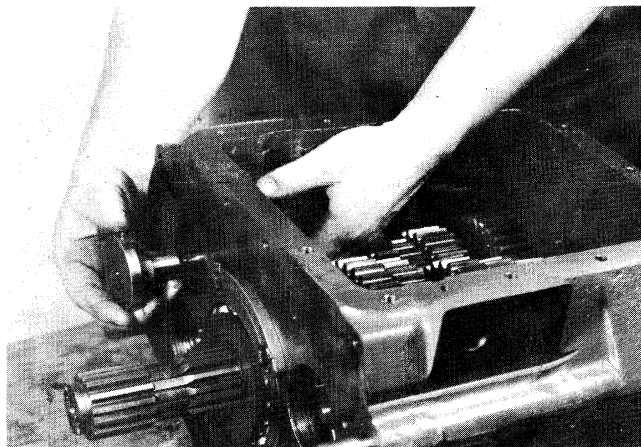

2. Push the shaft to the rear and remove from the case.

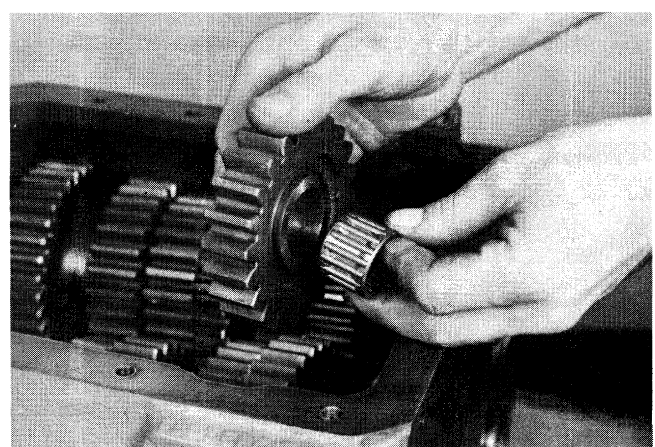

4. Remove the needle bearing from the gear.

**D. Removal and Disassembly of the Mainshaft**

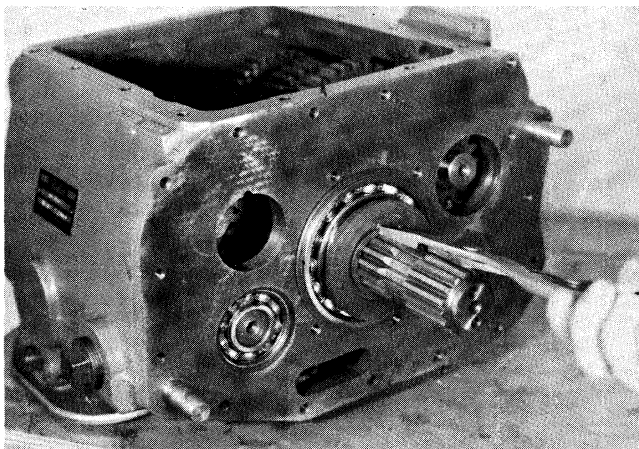
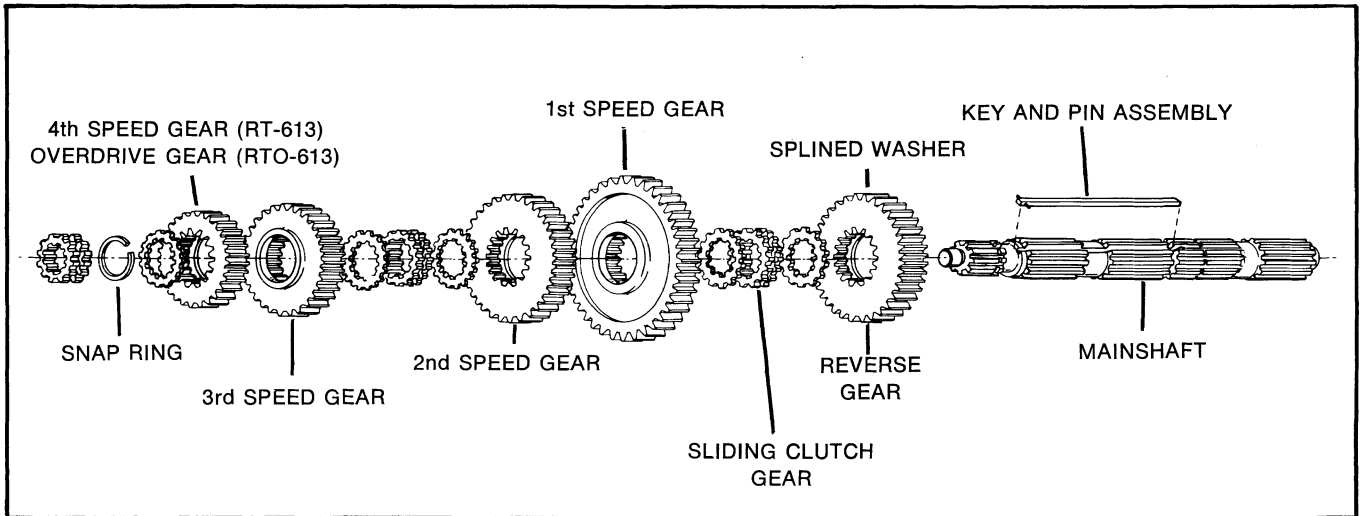

1. Remove the two mainshaft rear bearing retainers, and remove the snap ring from the groove in the rear of the mainshaft. Use caution as this will free the spring-loaded centering ring.

NOTE: It may be necessary to relieve pressure on the snap ring by tapping on the front of the mainshaft.

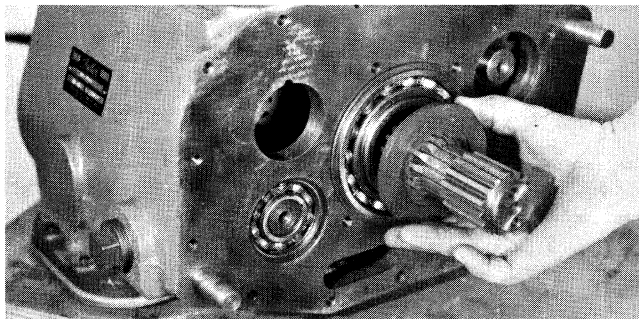

2. Remove the splined retainer from the mainshaft.

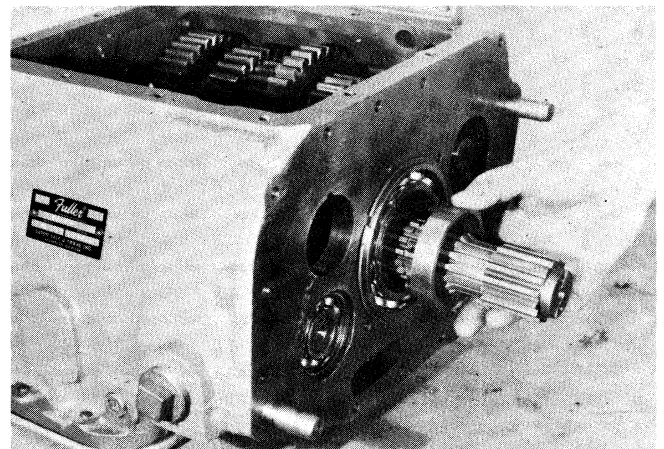

3. Center the front of the mainshaft in the case bore and remove the centering ring. Remove the six springs from the centering ring.

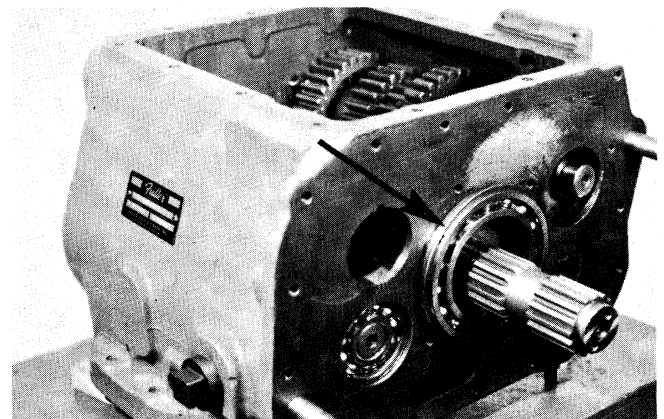

4. Keep the mainshaft centered and tap to the rear to expose the mainshaft rear bearing snap ring.

**D. Removal and Disassembly of the Mainshaft – Continued**

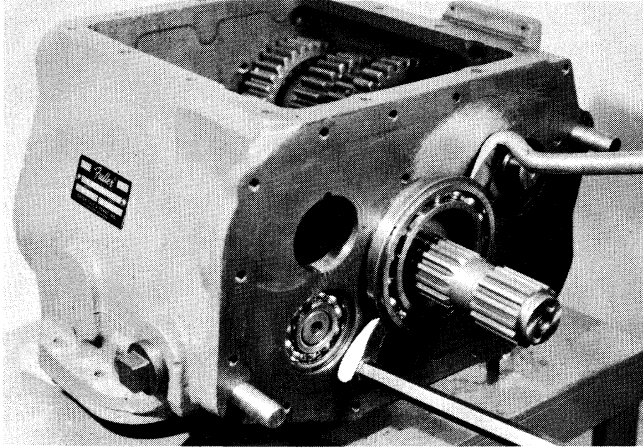

5. Remove the bearing from the case with pry bars.

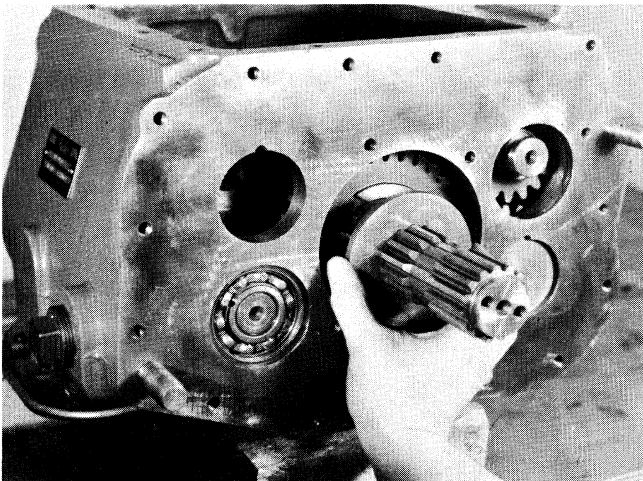

6. Remove the reverse gear washer from the mainshaft.

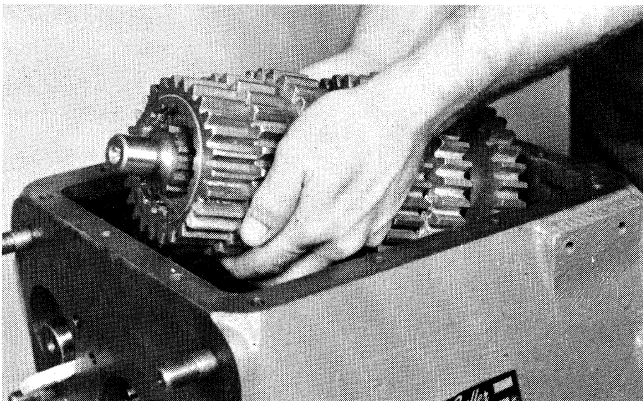

7. Block the right countershaft against the side of the case and move the mainshaft assembly to the rear. Tilt the front of the shaft up and lift the assembly from the case. Use caution as the reverse gear is free and can fall from the shaft during removal. Remove the reverse gear from the mainshaft.

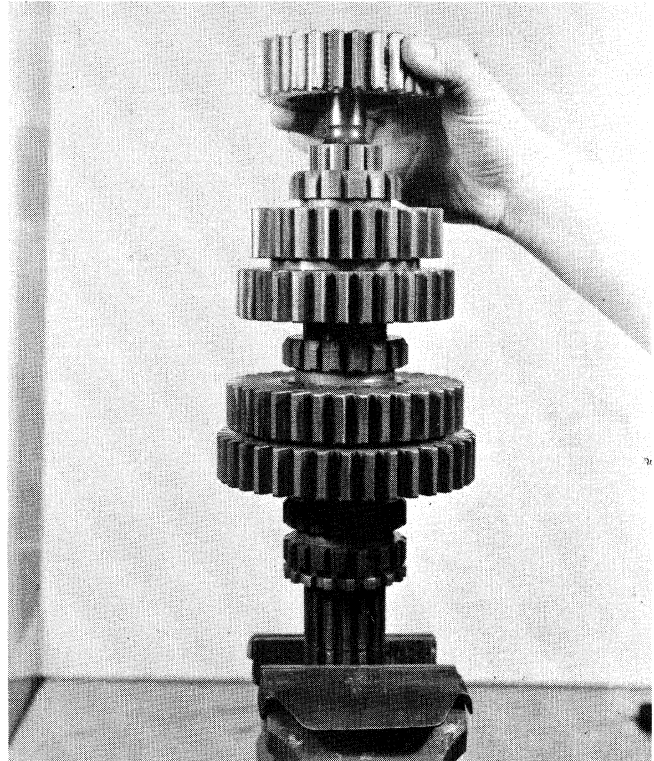

8. Secure the mainshaft assembly in a vise with the pilot (front) end up and remove the drivegear.

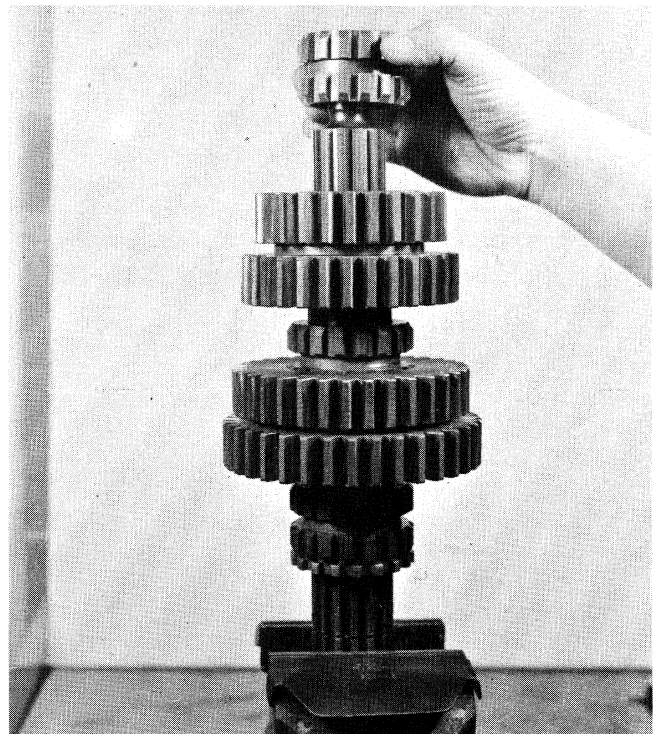

9. Remove the 4th-5th speed sliding clutch.



## DISASSEMBLY – FRONT SECTION

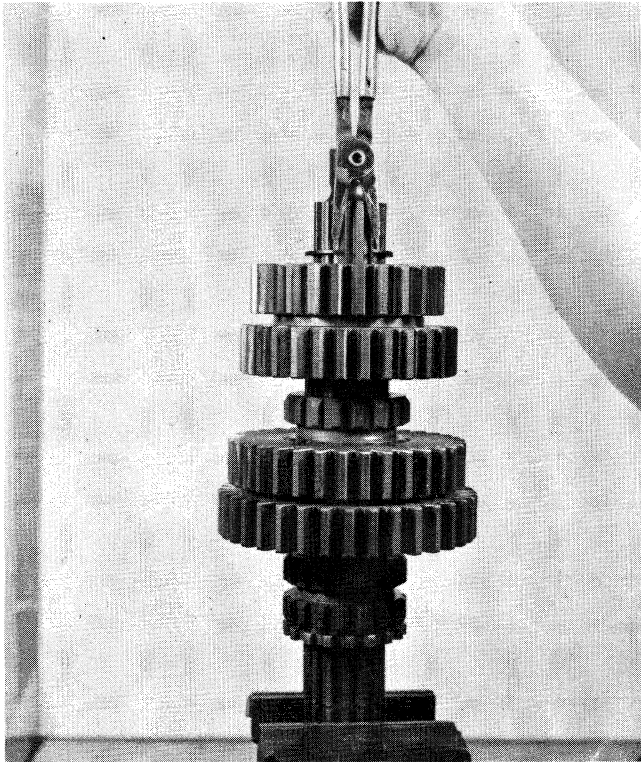

10. Remove the snap ring from the groove in the hub of the 4th speed gear.

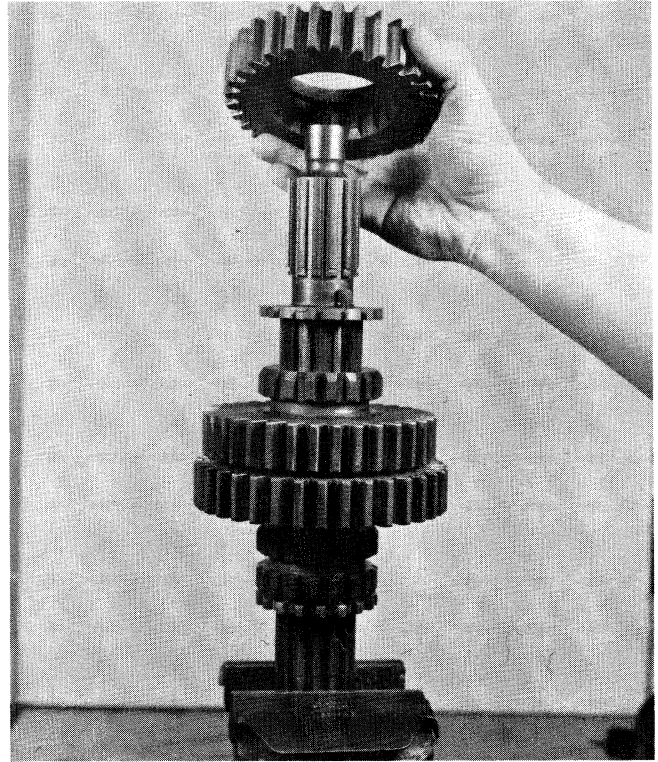

12. Remove the 3rd speed gear.

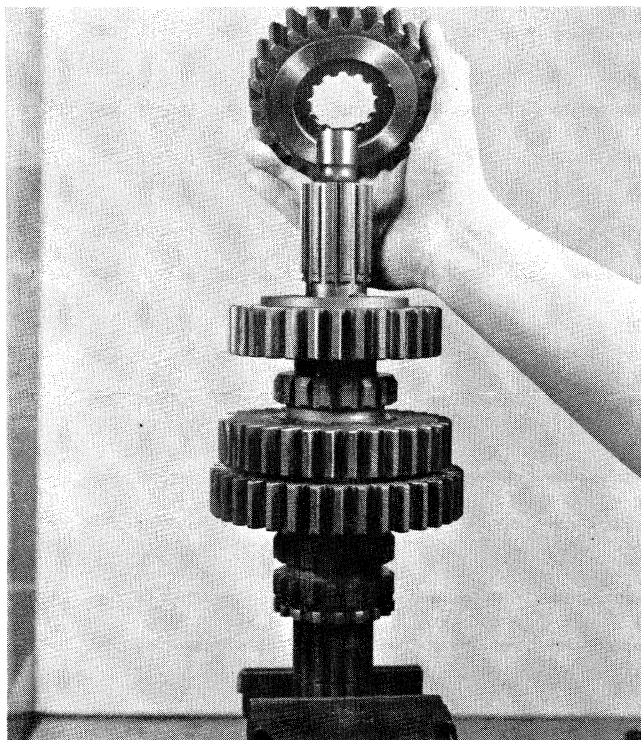

11. Remove the 4th speed gear and splined washer.

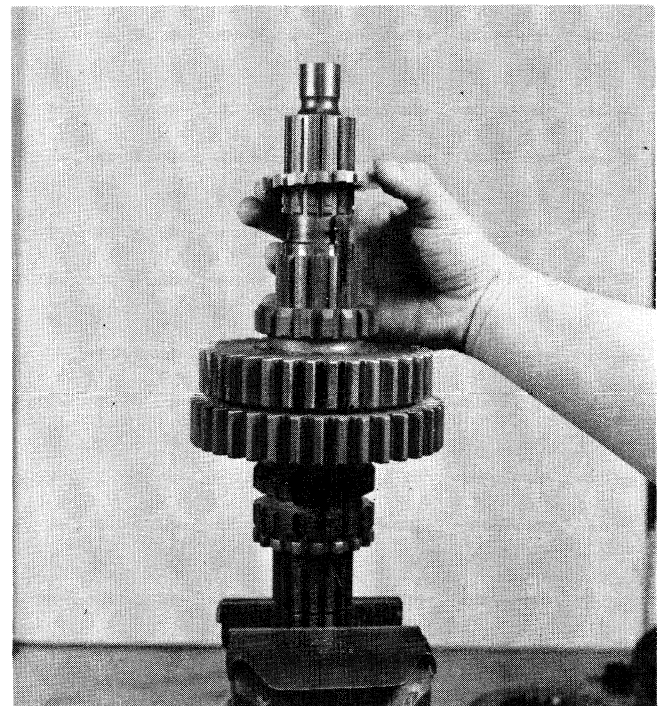

13. Lift the key and remove the 3rd speed gear splined washer.

## DISASSEMBLY – FRONT SECTION

### D. Removal and Disassembly of the Mainshaft – Continued

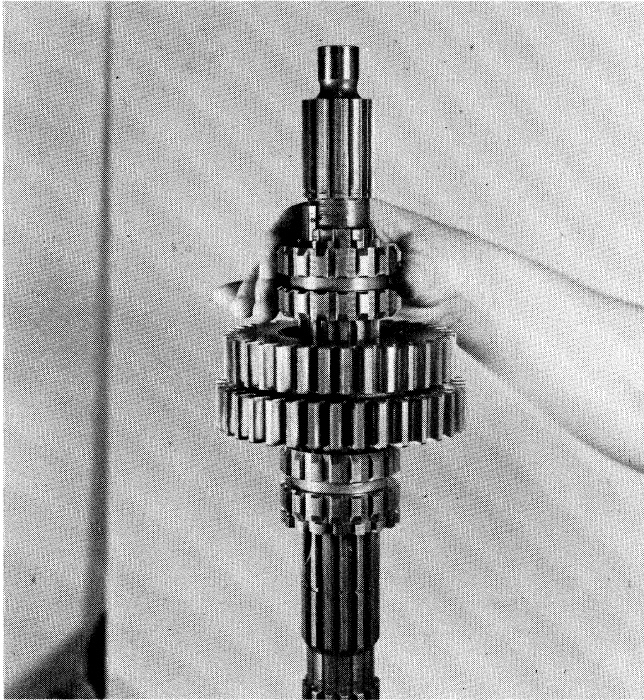

14. Remove the 2nd-3rd speed sliding clutch.

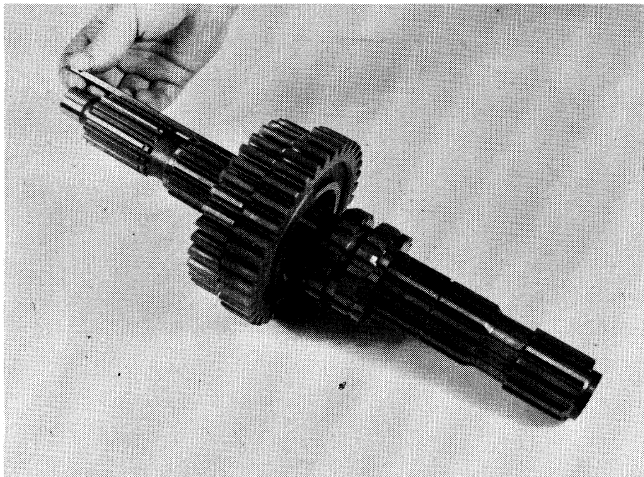

15. Remove the assembly from the vise and pull the key from the mainshaft.

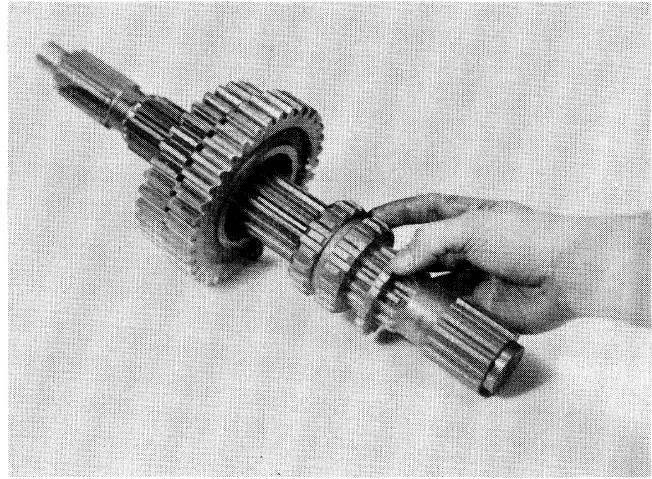

16. Remove the reverse gear splined spacer and the 1st-reverse sliding clutch.

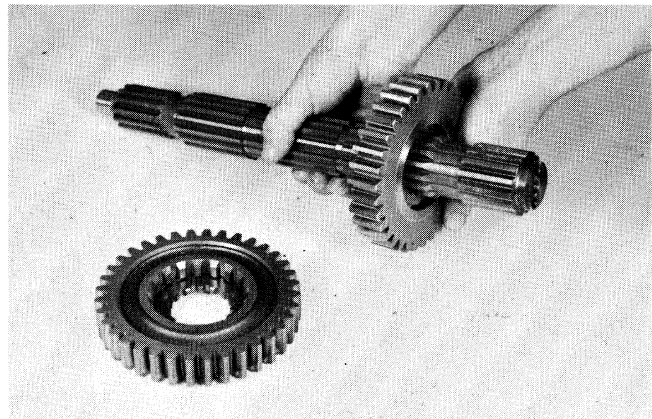

17. Remove the 1st and 2nd speed gears and splined spacers.

**E. Removal and Disassembly of the Countershaft Assemblies**

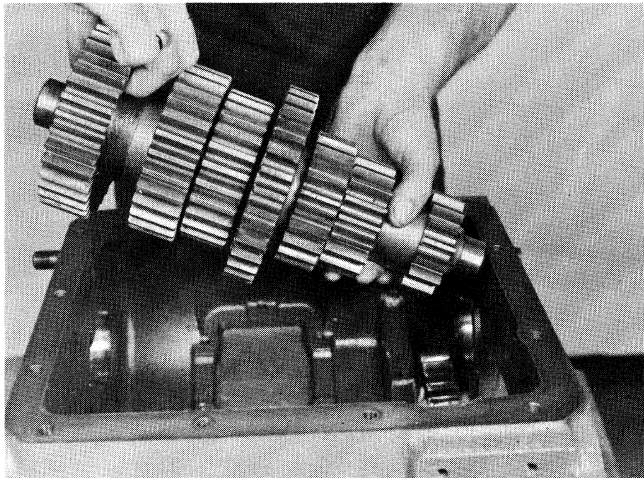
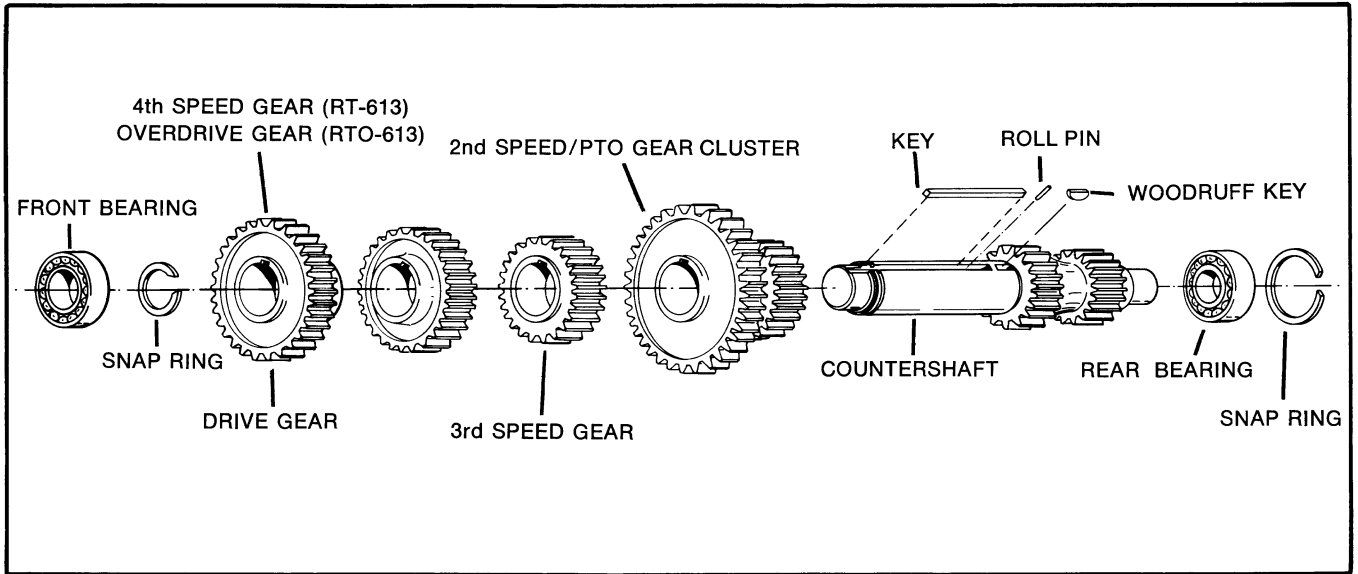

1. Remove the blocking and lift the right countershaft from the case.

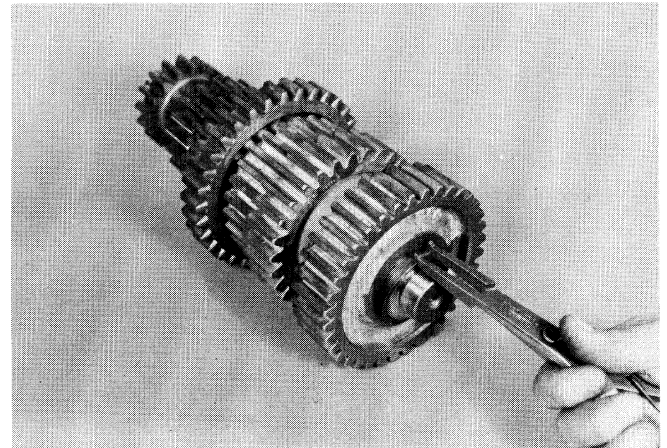

3. Remove the snap ring from the front of both countershafts.

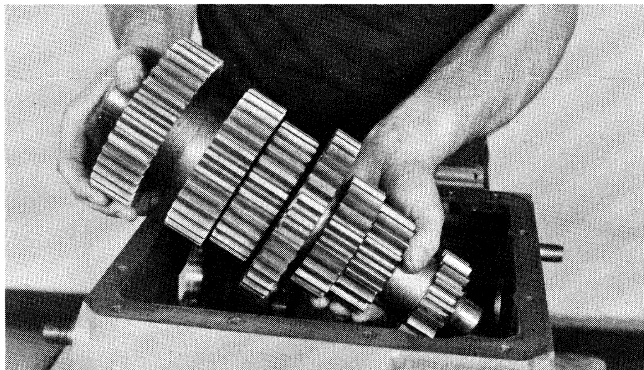

2. Remove the left countershaft bearings in the same manner as those removed from the right and lift the left countershaft from the case.



## DISASSEMBLY – FRONT SECTION

### E. Removal and Disassembly of the Countershaft Assemblies – Continued

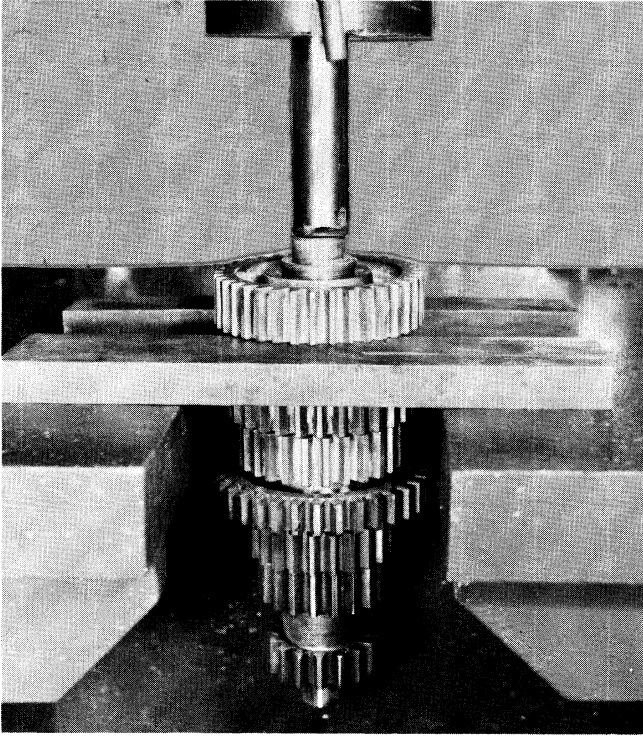

4. Press the drive gear from the shaft.

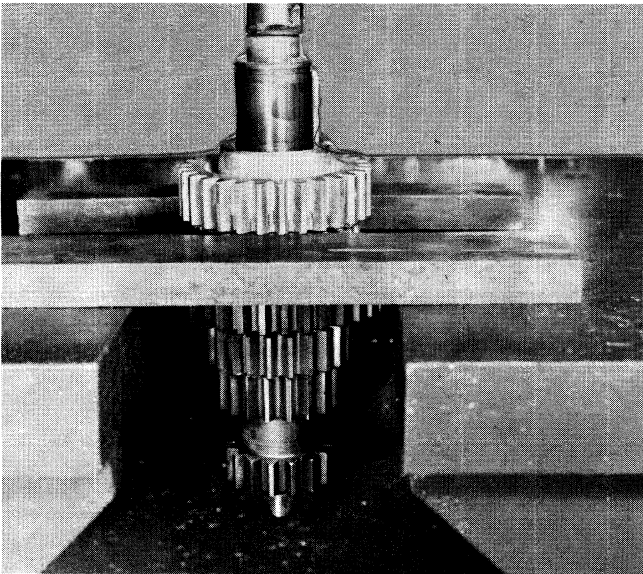

5. Press the 4th speed gear from the shaft.

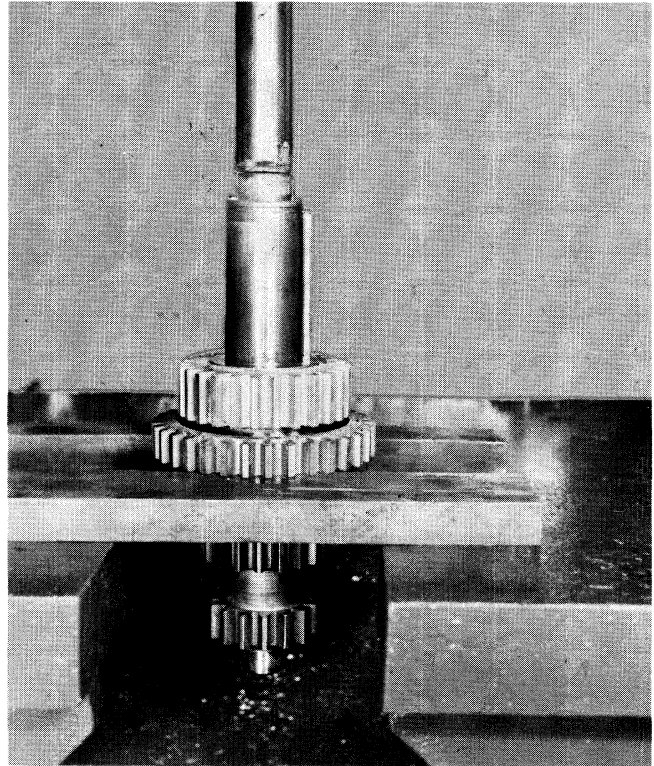

6. Using the rear face of the PTO gear as a base, press the 3rd speed gear and PTO/2nd speed gear cluster from the shaft. If necessary, remove the Woodruff key, long key and roll pin from the shaft.

NOTE: Countershafts are identical and disassembled in the same manner.

### F. Removal of the Right Reverse Idler Gear

1. Remove the right reverse idler gear in the same manner as the left, as both are identical.

# INSPECTION

Before reassembling the transmission, the individual parts should be carefully checked to eliminate those damaged from previous service. This inspection procedure should be carefully followed to insure the maximum of wear life from the rebuilt unit.

The cost of a new part is generally a small fraction of the total cost of downtime and labor, should the use of a questionable part make additional repairs necessary before the next regularly scheduled overhaul.

Recommended inspection procedures are set forth in the following check list:

## A. Bearings

1. Wash all bearings in clean solvent. Check balls, rolls and races for pits and spalled areas. Replace bearings which are pitted or spalled.
2. Lubricate bearings which are not spalled or pitted and check for axial and radial clearances. Replace bearings with excessive clearances.

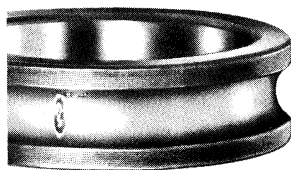

3. Check fits of bearings in case bores. If outer races turn freely in the bores, the case should be replaced.

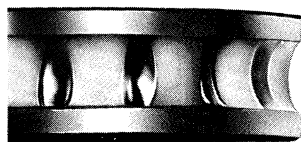

## B. Gears

1. Check operating gear teeth for pitting on the tooth faces. Gears with pitted teeth should be replaced.
2. Check all engaging gear teeth. Gears with teeth worn, tapered or reduced in length from clashing in shifting should be replaced.
3. Check axial clearances of gears. Where excessive clearance is found, check gear snap ring, washer, spacer and gear hub for excessive wear. Maintain .005 to .011 axial clearance of mainshaft forward speed gears, .011 to .032 on reverse gear.

## C. Splines

1. Check splines on all shafts for wear. If sliding clutch gears, companion flange or clutch hub have worn into the sides of the splines, the shafts in this condition should be replaced.

## D. Thrust Washers

1. Check surfaces of all thrust washers. Washers scored or reduced in thickness should be replaced.

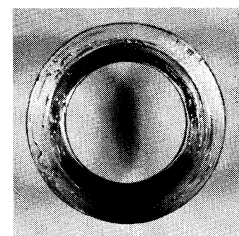

## E. Reverse Gear and Shaft

1. Check bearing sleeve for wear from action of roller bearings.

## F. Gray Iron Parts

1. Check all gray iron parts for cracks and breaks. Replace or repair parts found to be damaged. Heavy castings may be welded or brazed providing the cracks do not extend into bearing bores or bolting surfaces.

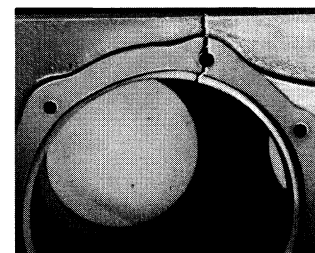

### G. Clutch Release Parts

1. Check clutch release parts. Replace yokes worn at cam surfaces and bearing carrier worn at contact pads.
2. Check pedal shafts. Replace those worn at bearing surfaces.

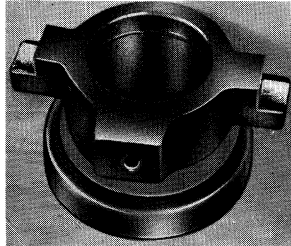

### H. Shifting Bar Housing Assembly

1. Check yokes and blocks for wear at pads and lever slot. Replace worn parts.
2. Check yokes for alignment. Straighten those which are sprung.
3. Check yokes for excessive wear; replace worn yokes.
4. Check lockscrews in yokes and blocks. Tighten and rewire those found loose.
5. If housing has been dismantled, check neutral notches of shifting bars for wear from interlock balls. Bars indented at points adjacent to the neutral notch should be replaced.

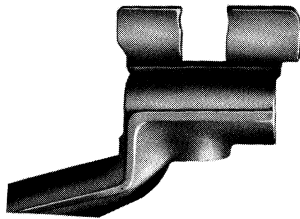

### I. Gear Shift Lever Housing Assembly

1. Check spring tension on shift lever. Replace tension spring and washer if lever moves too freely.
2. If housing is dismantled, check pivot pin and corresponding slot in lever for wear. Replace both parts if worn. If so equipped, check O-ring in housing for wear or cracks.

### J. Bearing Covers

1. Check covers for wear from thrust of adjacent bearing. Replace covers worn and grooved from thrust of bearing outer race.
2. Check bores of covers for wear. Replace those worn over-size.

### K. Oil Return Threads and Seals

1. Check oil return threads in front bearing cover. If sealing action of threads has been destroyed by contact with input shaft, replace the cover.
2. Check oil seal in mainshaft rear bearing cover. If sealing action of lip has been destroyed, replace seal.

### L. Synchronizers

1. Check high and low range synchronizers for burrs, uneven and excessive wear at contact surface.
2. Check blocker pins for excessive wear or looseness.
3. Check synchronizer contact surfaces on the high and low range gears for excessive wear.

### M. Sliding Clutches

1. Check all yokes and yoke slots in sliding clutches for extreme wear or discoloration from heat.
2. Check engaging teeth of sliding clutches for partial engagement pattern.

# GENERAL PRECAUTIONS FOR REASSEMBLY

**IMPORTANT: Read this section before starting the detailed reassembly procedures.**

Make sure that interiors of case and housing are clean. It is important that dirt be kept out of transmission during reassembly. Dirt is abrasive and can damage polished surfaces of bearings and washers. Use certain precautions, as listed below, during reassembly.

1. **GASKETS** — Use new gaskets throughout the transmission as it is being rebuilt. Make sure all gaskets are installed, as omission of gasket can result in oil leakage or misalignment of bearing covers. See "Location of Gaskets" heading.

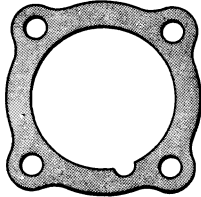

2. **CAPSCREWS** — To prevent oil leakage, use shellac on all capscrews. See torque rating chart for recommended torque.
3. **O-RINGS** — Lubricate all O-rings with "Dow Corning 200 Fluid," 50,000 cs.
4. **ASSEMBLY** — Refer to the disassembly illustrations as a guide to reassembly.
5. **INITIAL LUBRICATION** — Coat all thrust washers and splines of shafts with Lubriplate during installation to provide initial lubrication, preventing scoring and galling.
6. **AXIAL CLEARANCES**—Maintain original axial clearances of mainshaft forward speed gears of .005" to .011". Mainshaft reverse gear clearance is .011" to .032".

7. **BEARINGS** — Use of flanged-end bearing drivers is recommended for the installation of bearings. These

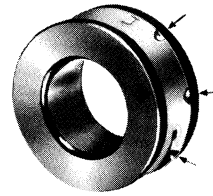

drivers apply equal force to both races of bearing, preventing damage to balls and races and maintaining correct bearing alignment with shaft and bore. If tubular or sleeve type driver is used, apply force only to inner race.

8. **UNIVERSAL JOINT COMPANION FLANGE** — Pull the companion flange tightly into place with the mainshaft nut, using 450-500 foot-pounds of torque. Make sure the speedometer gear has been installed on yoke. If a speedometer gear is not used, a replacement spacer of the same width must be used. Failure to pull the yoke or flange tightly into place will permit the shaft to move axially with resultant damage to rear bearing.

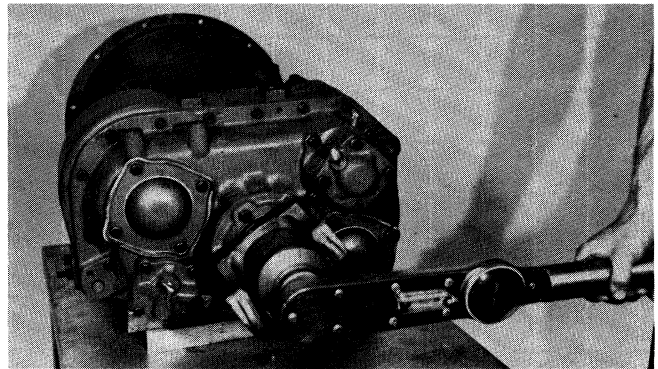

# REASSEMBLY INSTRUCTIONS

## I. FRONT SECTION

### A. Installation of the Right Reverse Idler Gear

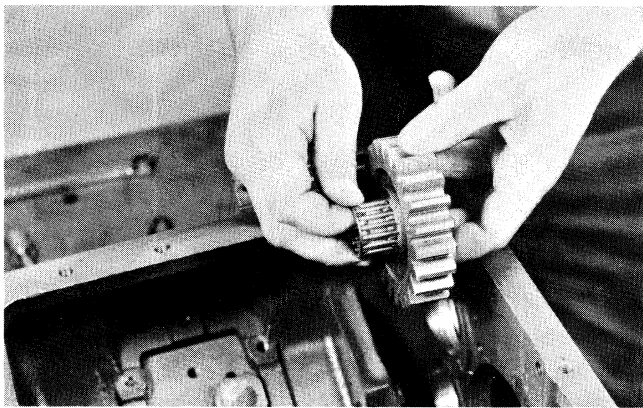

1. Install the needle bearing in the bore of the gear.

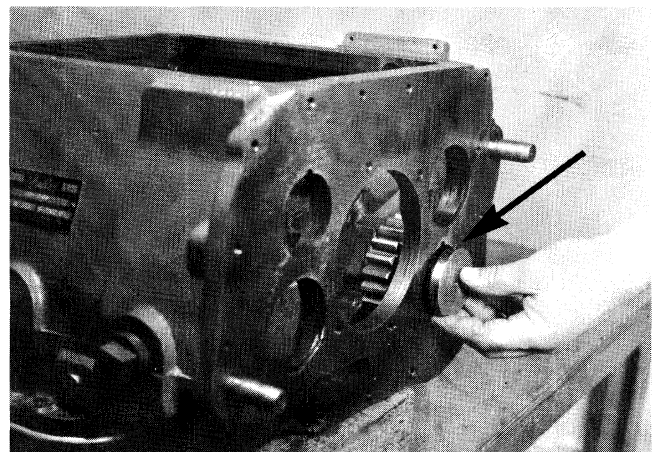

3. Make sure that the roll pin is in place in the large diameter of the idler shaft and insert the shaft through the gear, washer and boss, aligning the roll pin with the notch in the rear case bore.

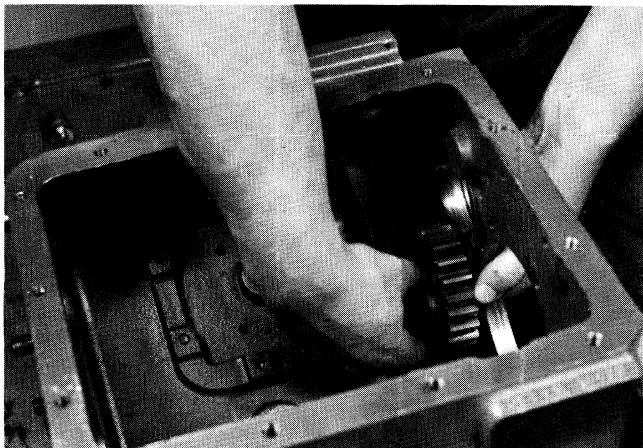

2. Slide the thrust washer into position on the rear of the case boss and hold the gear behind the washer.

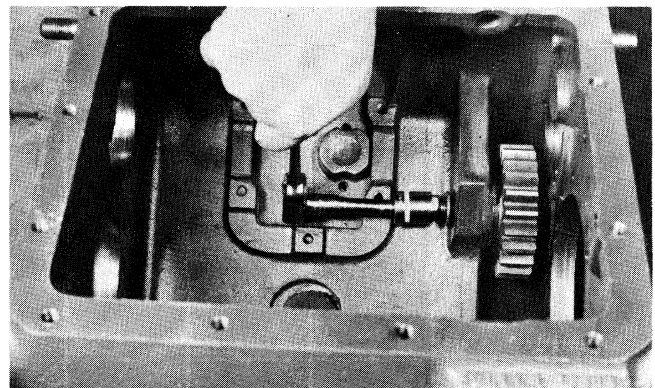

4. Secure the shaft with the washer and elastic stop nut.



## B. Reassembly and Installation of the Countershafts

NOTE: Countershafts are identical and assembled in the same manner.

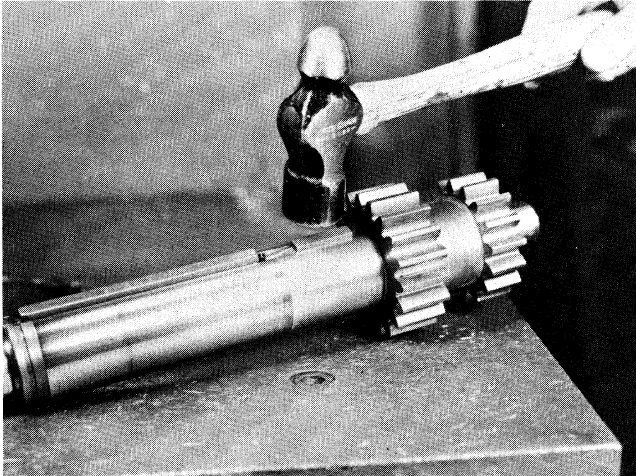

1. If previously removed, install the roll pin, long key and Woodruff key in the countershaft.

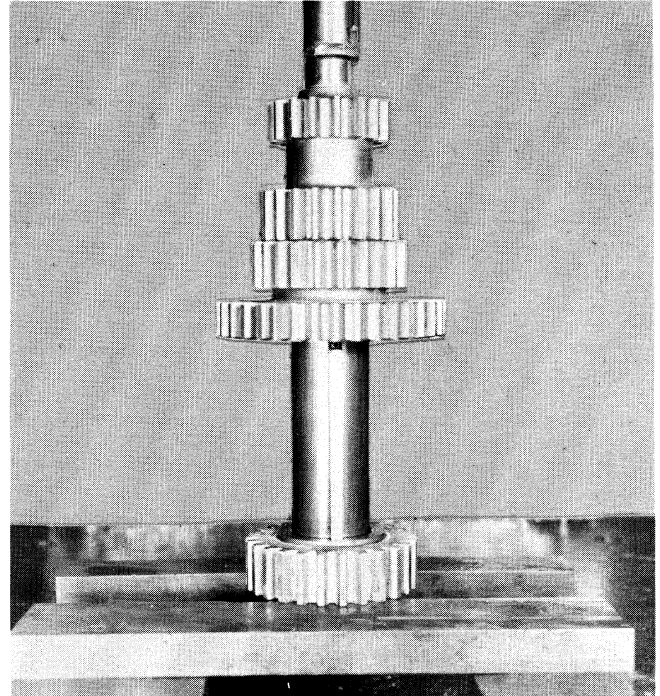

3. Press the 3rd speed gear onto the shaft with the long hub to the rear.

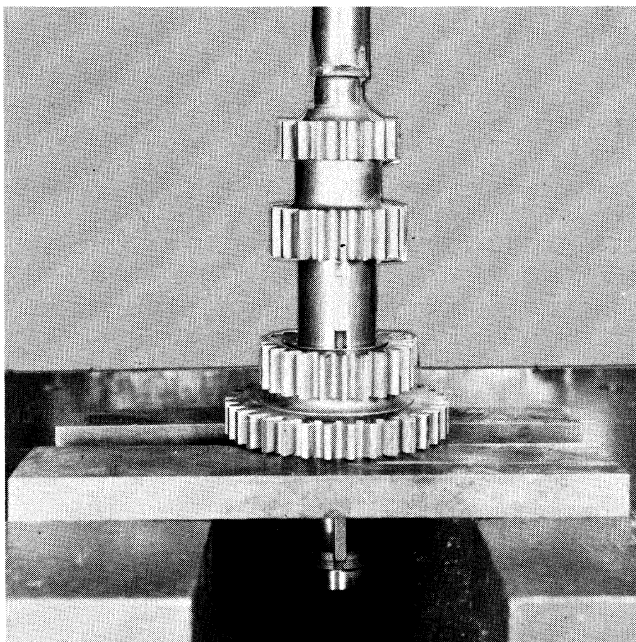

2. Press the PTO/2nd speed gear cluster onto the shaft.

NOTE: For RTO-613 models, the drive gear and 4th speed gear locations are reversed.

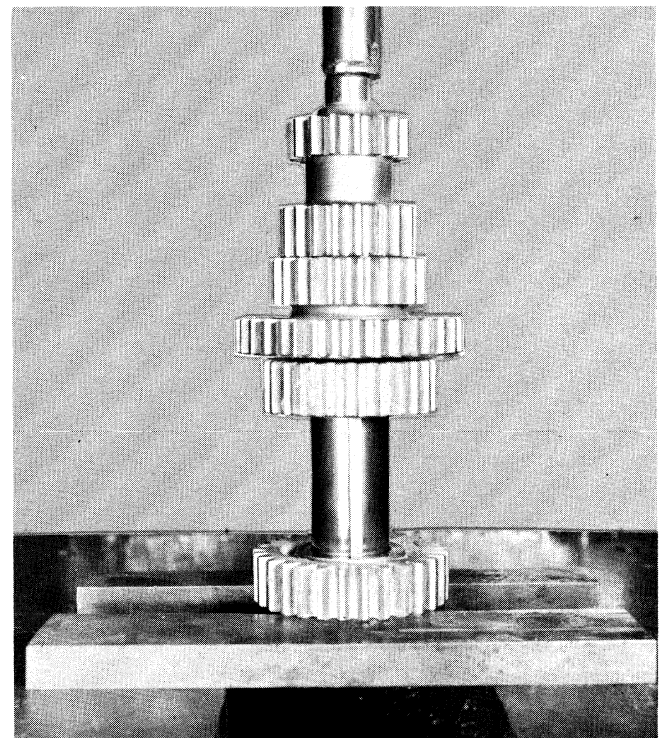

4. Press the 4th speed gear onto the shaft with the long hub to the front.



**B. Reassembly and Installation of the Countershafts – Continued**

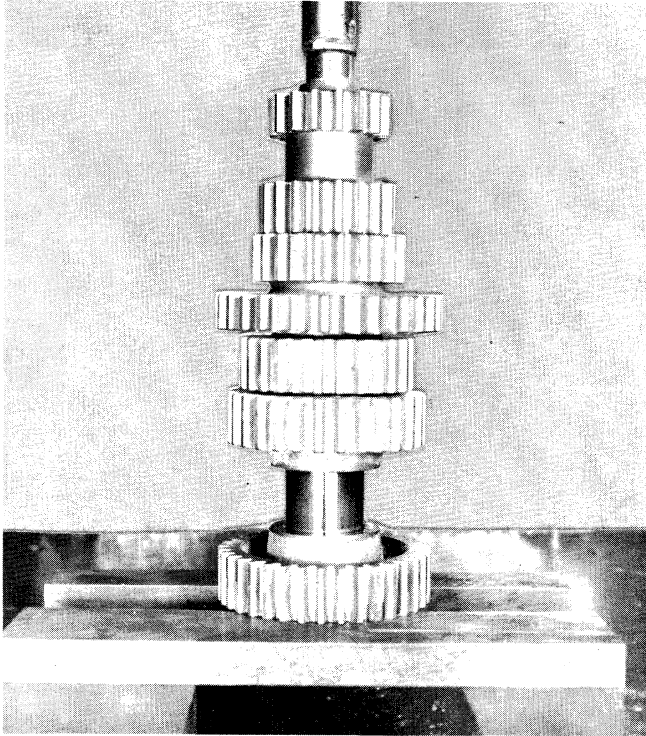

5. Press the drive gear onto the shaft with the long hub to the rear.

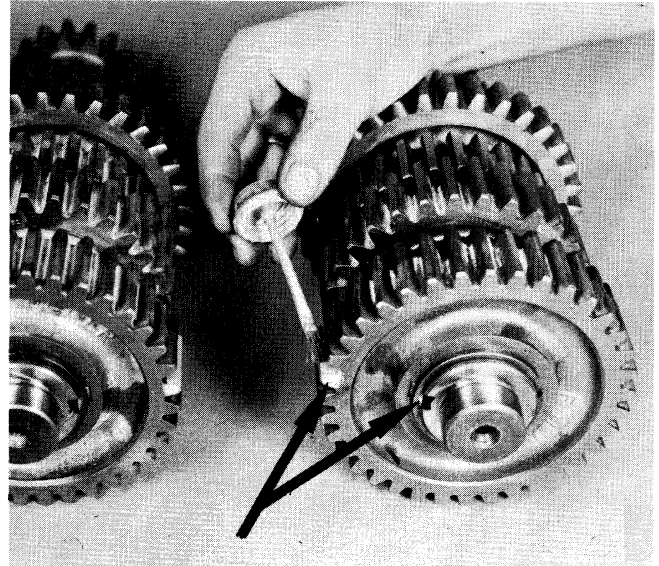

7. On the drive gear of each shaft mark the gear tooth which is aligned with the keyway. The tooth is also stamped with an "O".

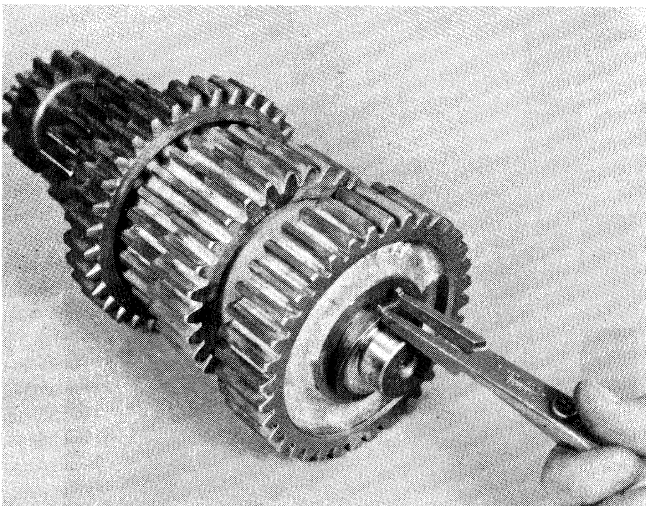

6. Install the snap ring in the groove in the front of the countershaft.

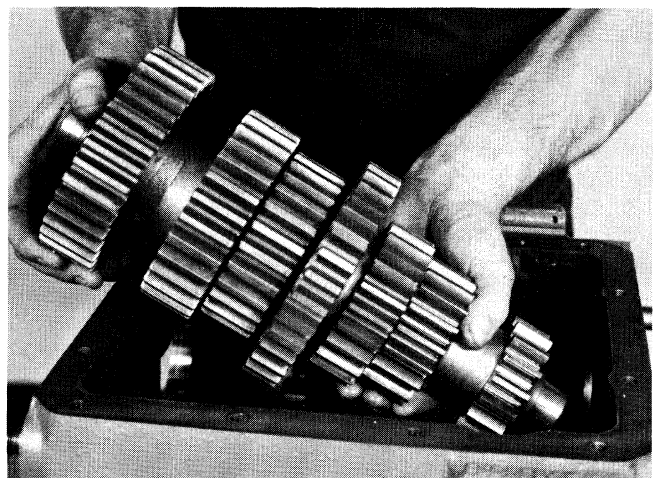

8. Place the left countershaft into position in the case.

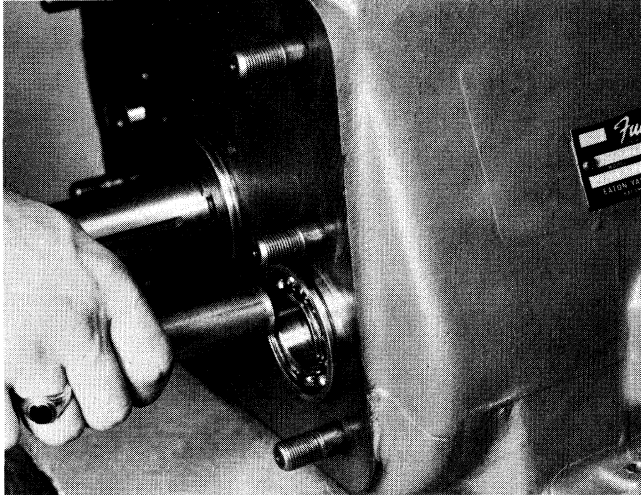

9. Center the rear of the countershaft in the case bore and partially install the front bearing on the shaft and in the case bore. Partially install the rear bearing.

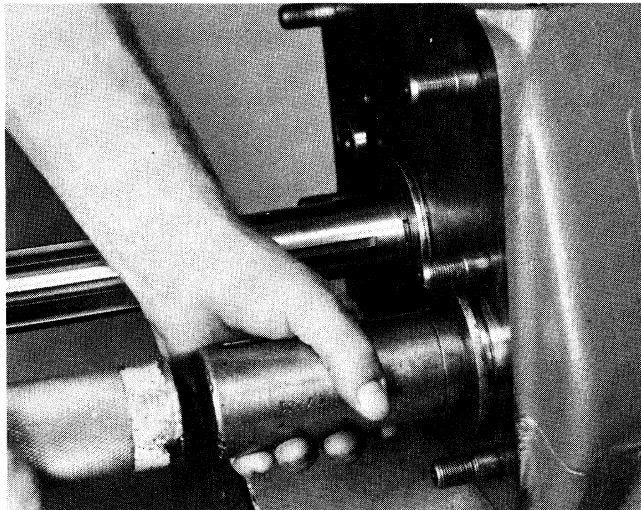

10. Use a bearing driver to complete installation of the front and rear bearings.

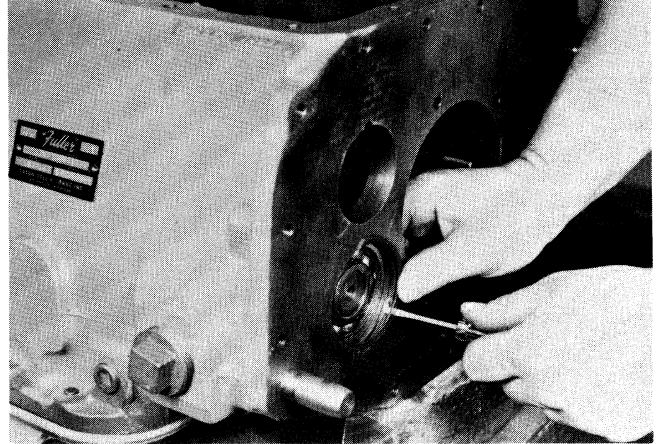

11. Install the snap ring in the groove in the rear bearing bore.

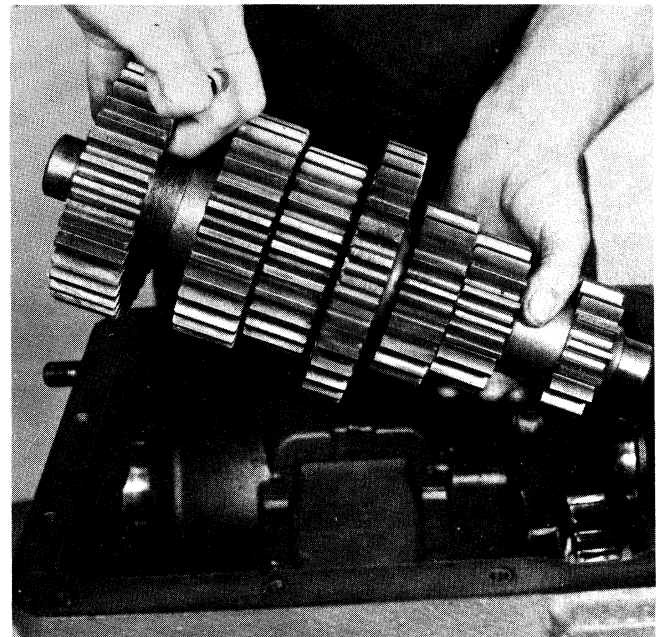

12. Place the right countershaft into position but **DO NOT** install the bearings.

# REASSEMBLY – FRONT SECTION

## C. Reassembly of the Mainshaft

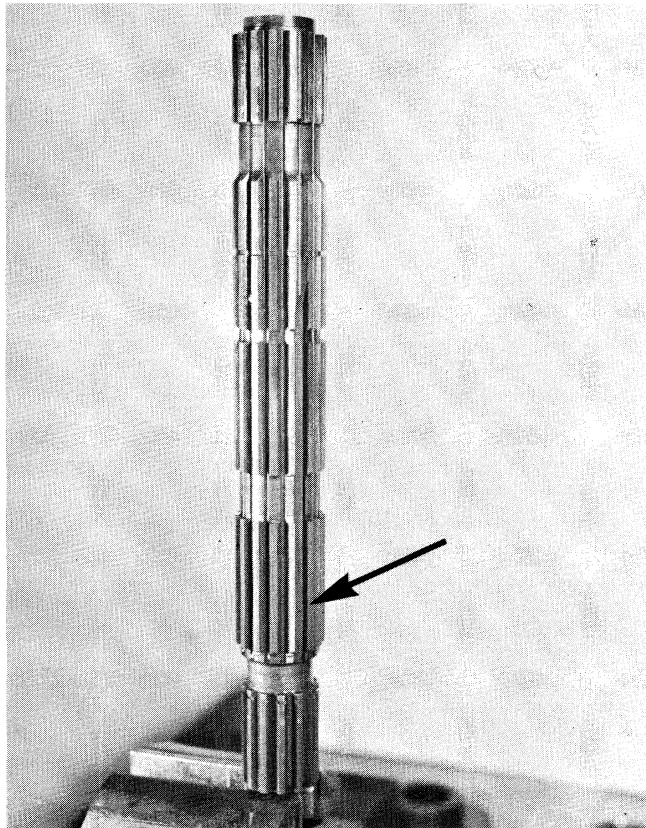

1. Place the mainshaft in a vise with the pilot (front) end down, keeping the keyway free for insertion of the key.

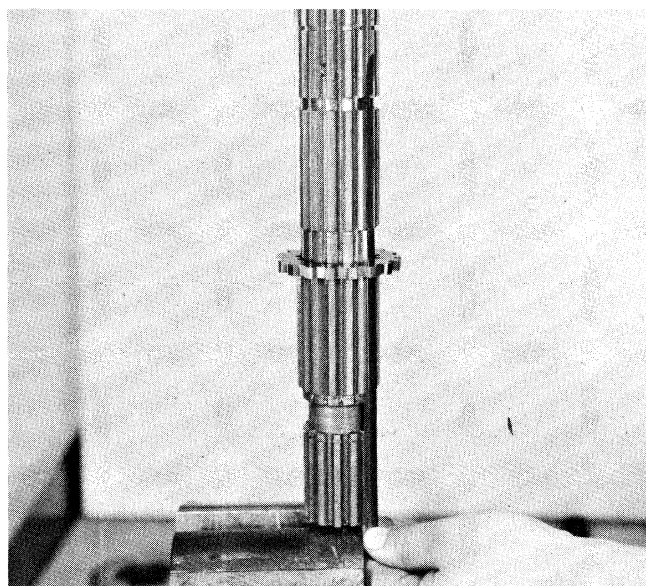

2. Install the 2nd speed gear washer at the 2nd speed gear location, inserting the key from the bottom to lock the washer in position.

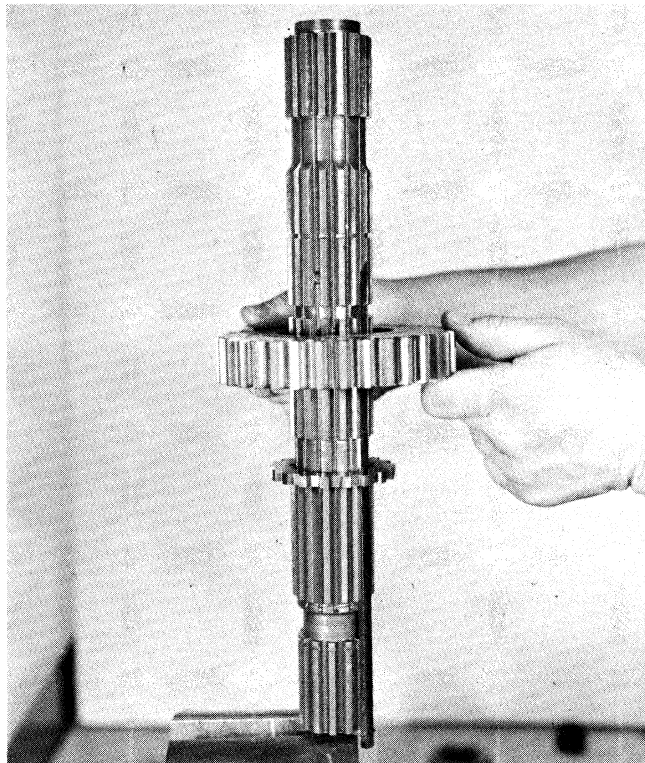

3. Install the 2nd speed gear on the splined washer, clutching teeth down.

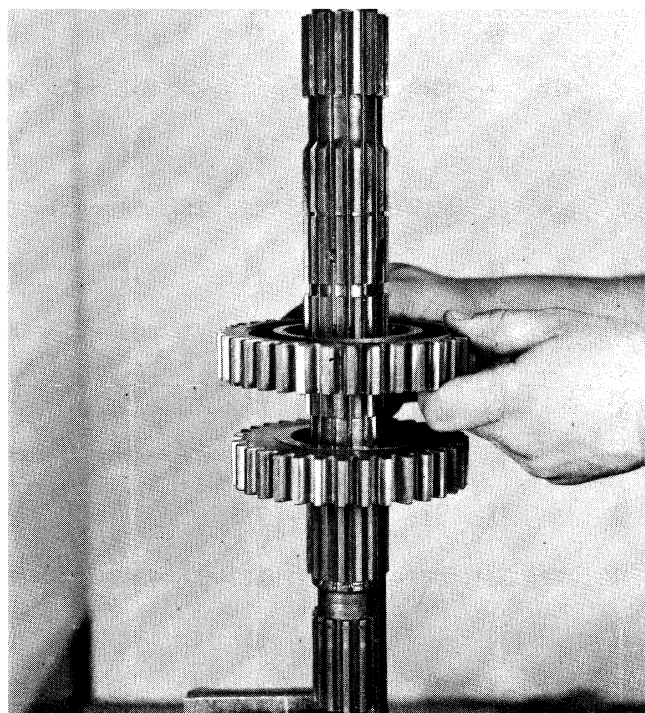

4. Install the 1st speed gear against the 2nd speed gear, clutching teeth up.



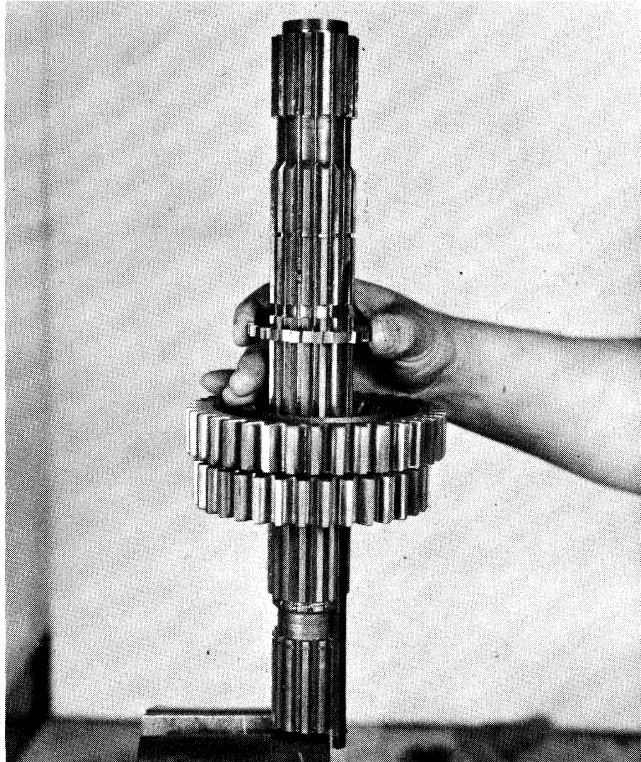

5. Insert the splined washer in the hub of the 1st speed gear. Align the washer with the mainshaft splines and move the key up to lock the washer in position.

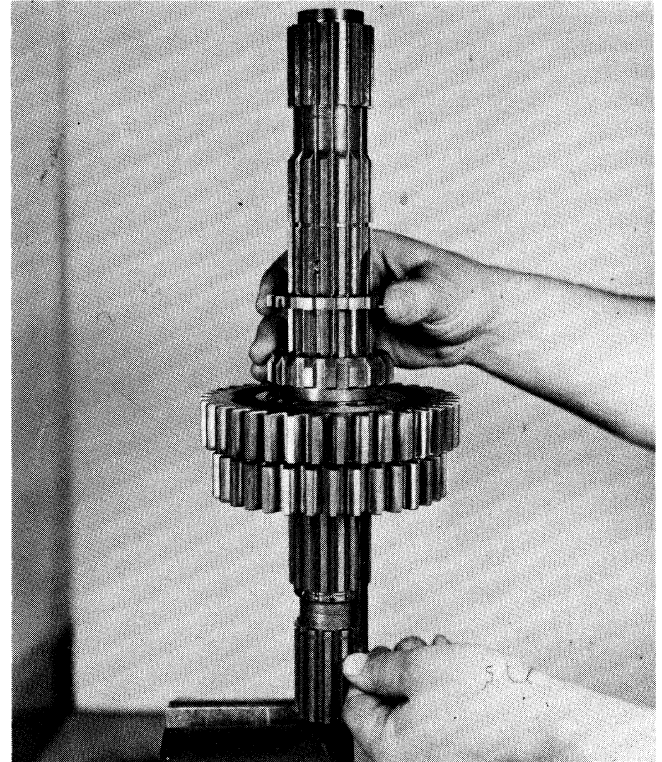

7. Install the reverse gear splined washer, align the keyway and lock in position with the key.

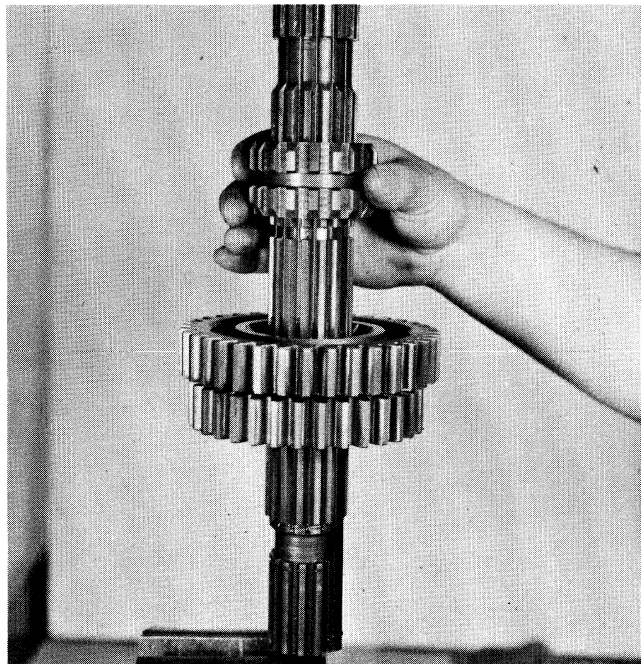

6. Install the 1st-reverse sliding clutch, aligning the slot in the clutch with the key.

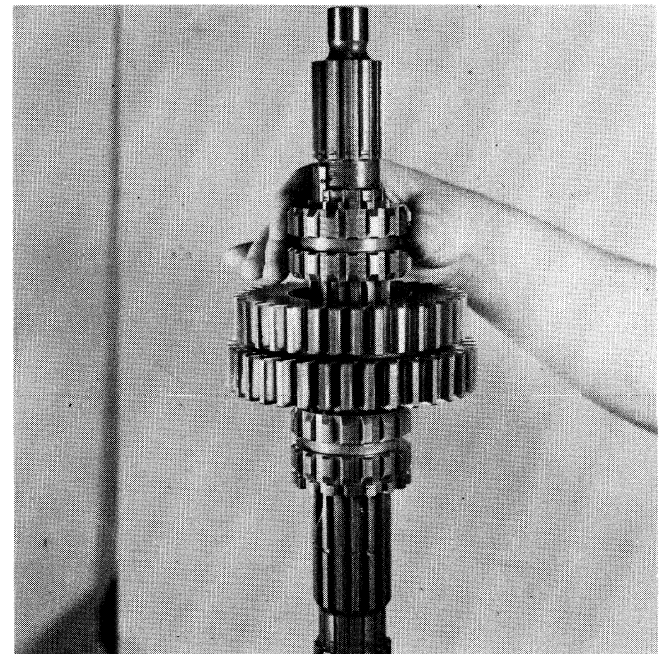

8. Reposition the assembly in the vise with the pilot end up and pull the key up approximately  $\frac{1}{2}$ ". Install the 2nd-3rd speed sliding clutch, aligning the slot in the clutch with the key.

**C. Reassembly of the Mainshaft – Continued**

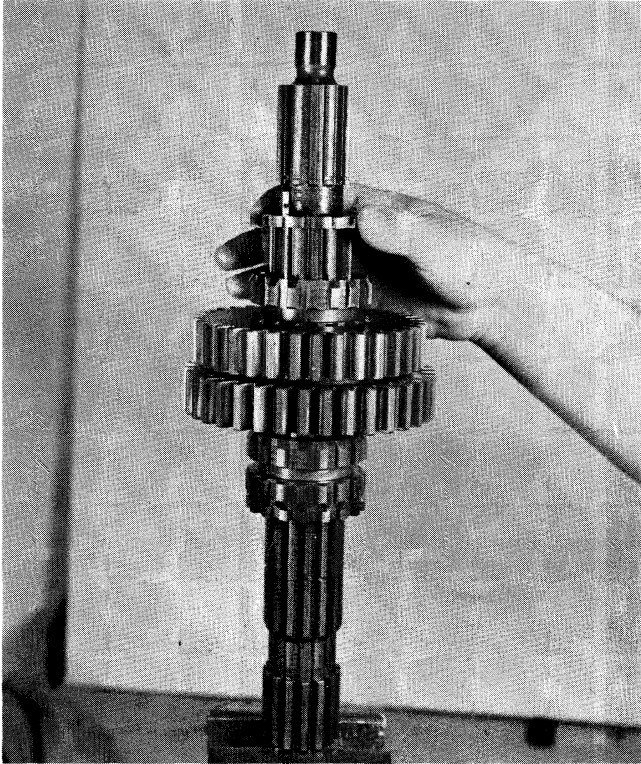

9. Slide the 3rd speed gear splined washer down over the key and push the key down into position, with the pin in the key resting on top of the washer.

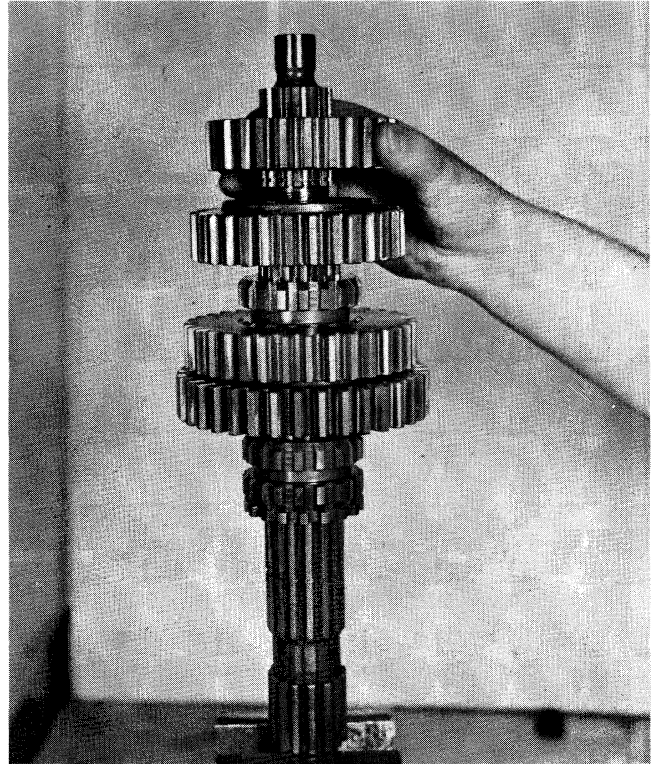

11. Install the 4th speed gear against the 3rd speed gear, clutching teeth up.

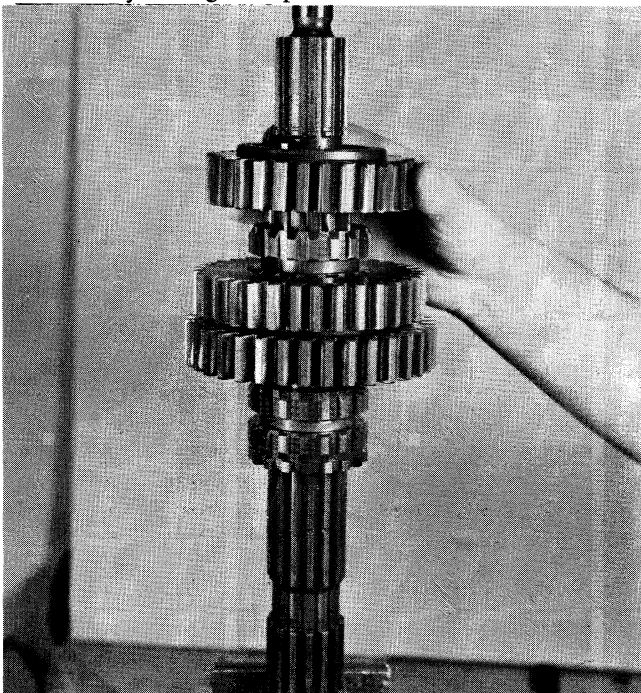

10. Install the 3rd speed gear on the splined washer, clutching teeth down.

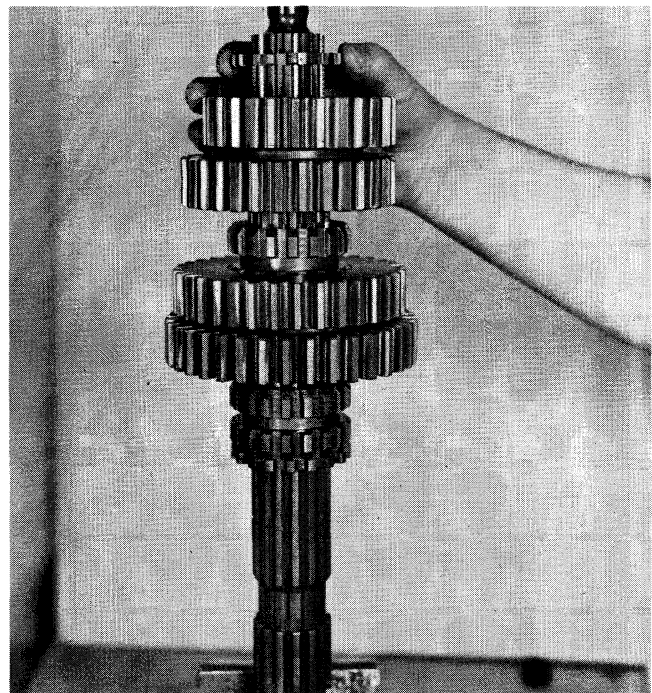

12. Install the 4th speed gear splined washer on the shaft and in the hub of the gear.



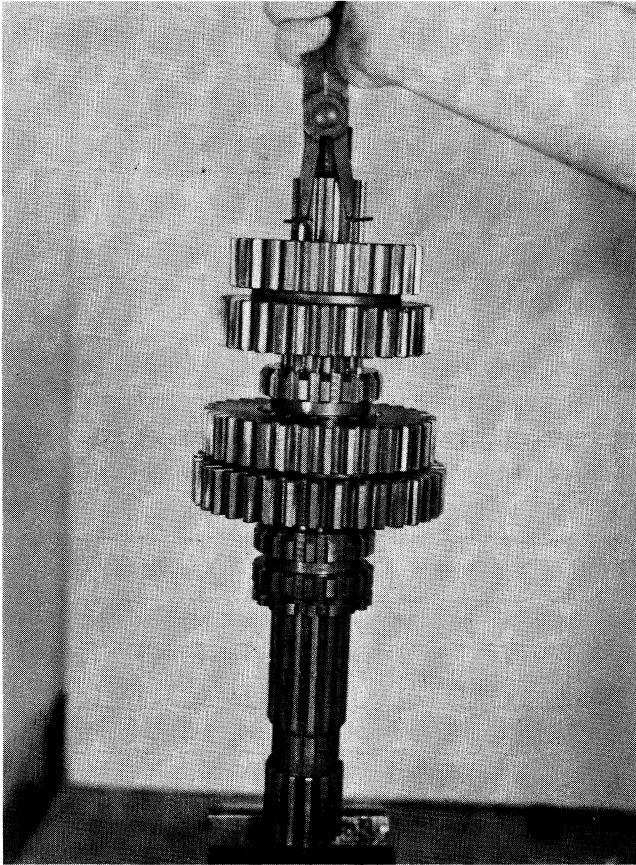

13. Install the snap ring in the groove in the mainshaft to secure the 4th speed gear splined washer.

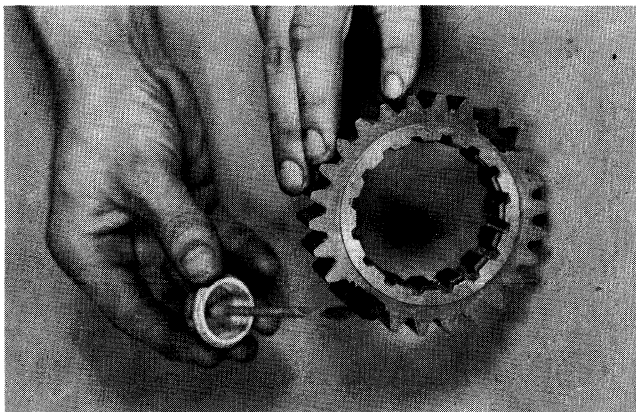

14. **IMPORTANT:** Mark two adjacent teeth on the drive gear and the two teeth directly opposite for timing purposes.

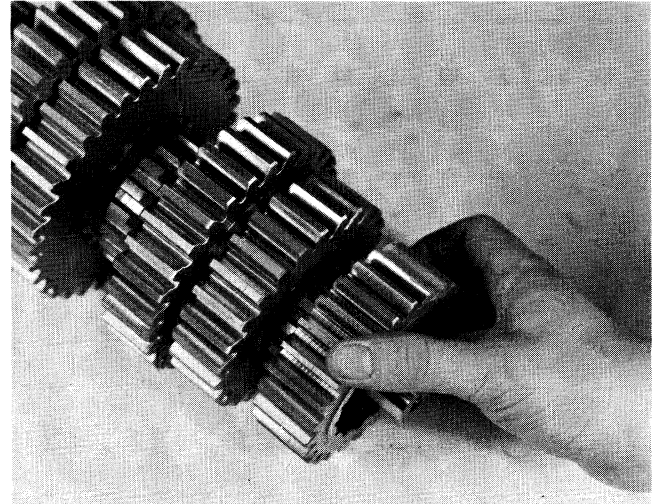

15. Remove the mainshaft from the vise. Install the 4th-5th speed sliding clutch on shaft and install the drive gear against the 4th speed gear, clutching teeth towards the 4th speed gear and engaging the sliding clutch.

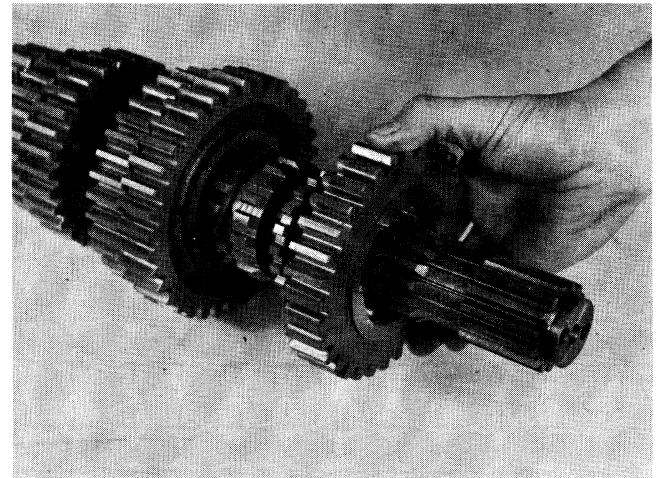

16. Place the reverse gear on the splined washer which is locked to the shaft.



## REASSEMBLY – FRONT SECTION

### D. Installation of the Mainshaft Assembly

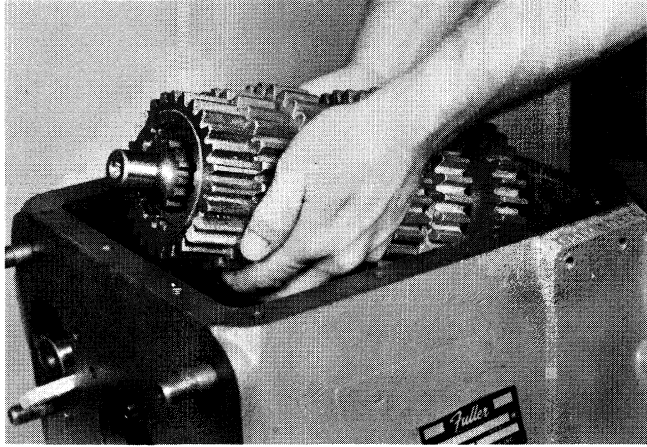

1. Block the right countershaft against the wall of the case and place the mainshaft into position, meshing gears with those of the left countershaft.

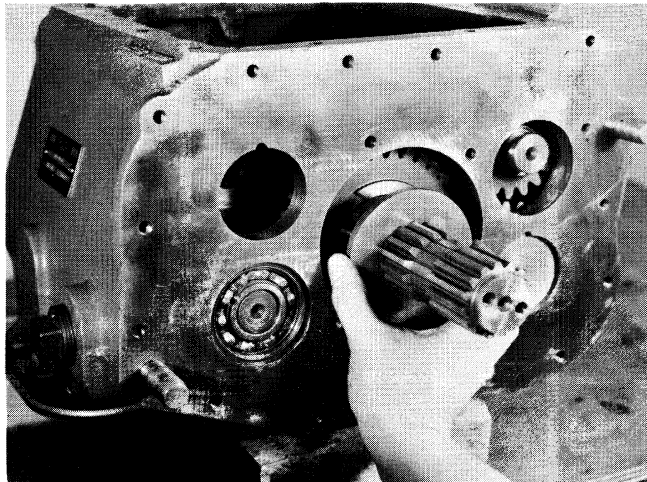

2. Install the reverse gear washer, flat side to the rear.

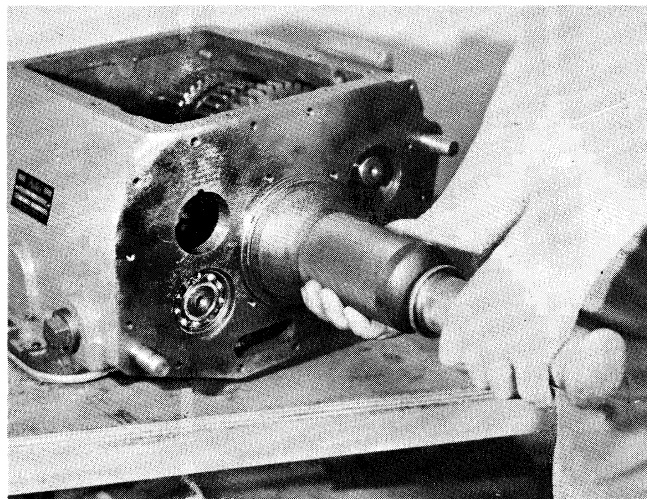

3. Seat the mainshaft rear bearing in the case bore.

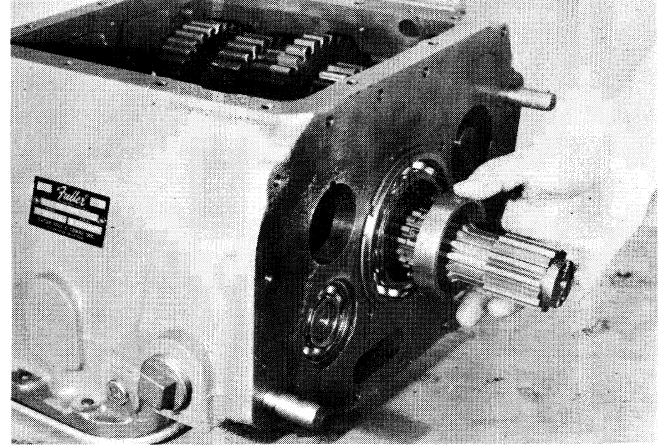

4. Install the six springs in the centering ring using a small amount of grease or equivalent in each of the centering ring bores to hold the springs in place. Place the centering ring on the shaft and slide into the rear bearing against the reverse gear washer.

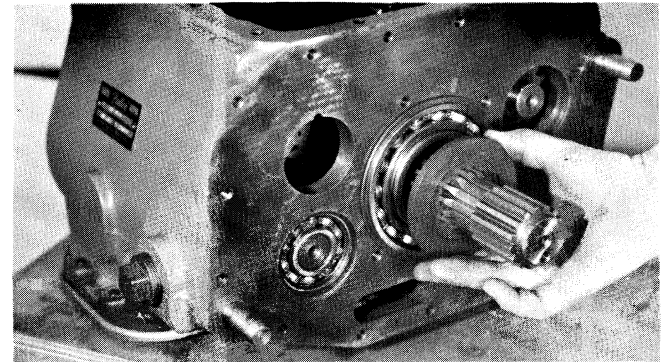

5. Install the splined retainer washer on the shaft, cone surface towards the centering ring.

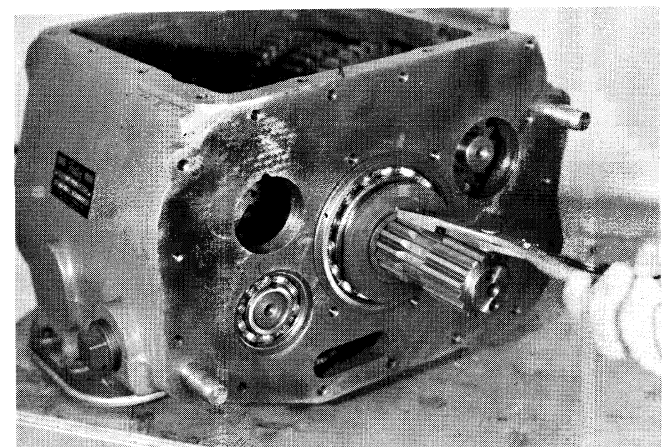

6. Place the snap ring on the shaft against the splined retainer washer.

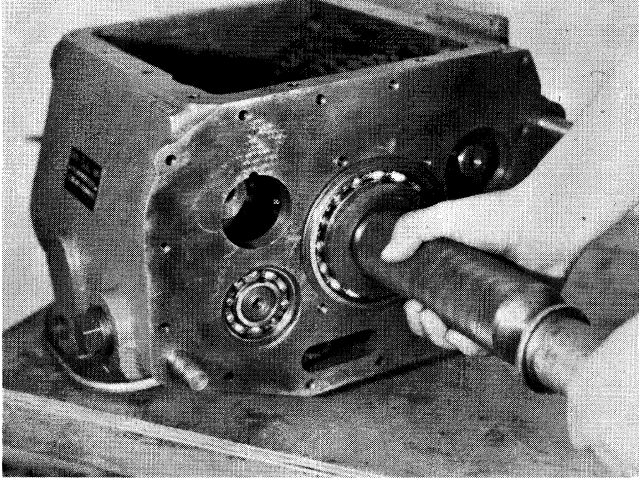

7. Block against the front of the mainshaft and use a sleeve driver to move the centering ring, retainer washer and snap ring forward until the snap ring seats in the groove in the mainshaft.

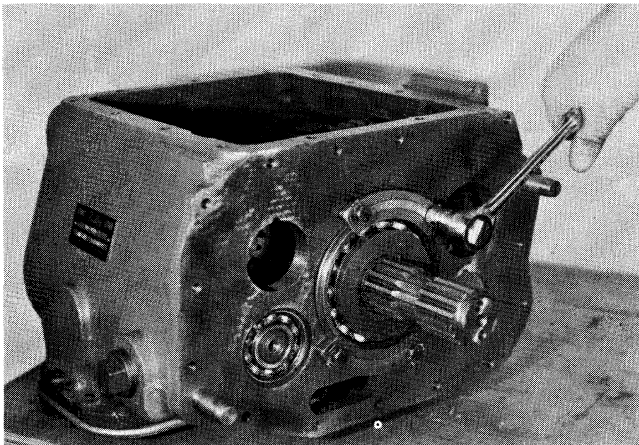

8. Install the rear bearing retainers and secure the cap-screws with the locking lugs.

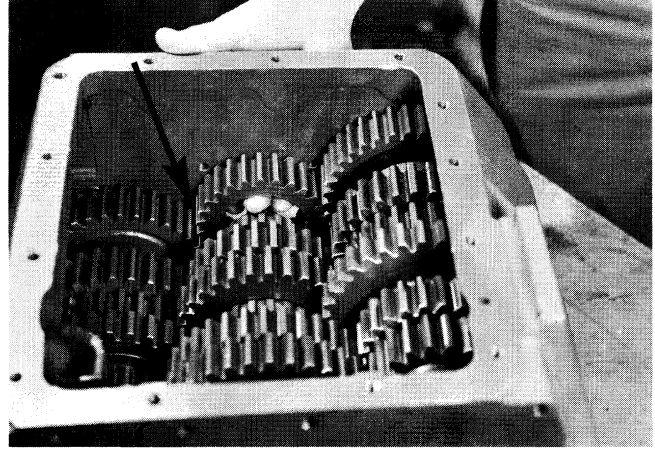

9. Slide the drive gear forward off the splines of the sliding clutch and align the timing marks with the marked tooth on the left countershaft.

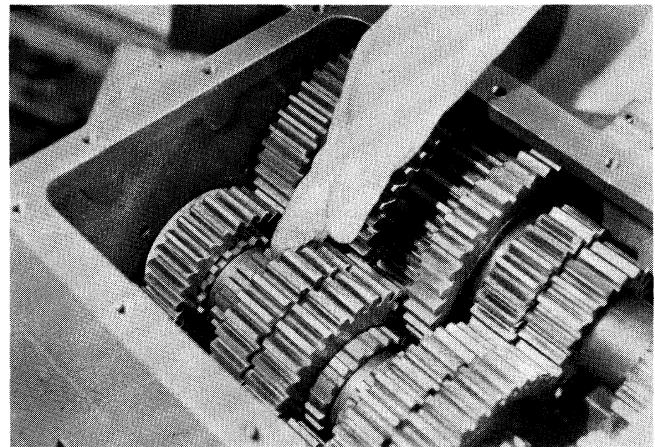

10. Slide the 4th-5th speed sliding clutch forward to engage the splines of the drive gear.



## REASSEMBLY – FRONT SECTION

### E. Installation of the Clutch Shaft

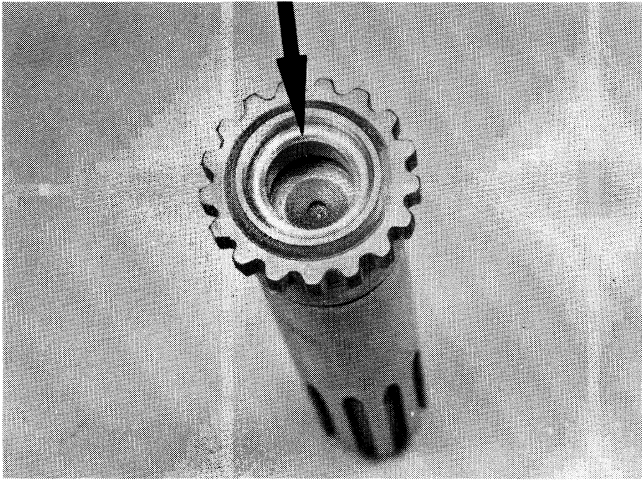

1. If previously removed, install bushing in pocket of clutch shaft; install flush with shaft, making sure that oil hole in shaft is not plugged.

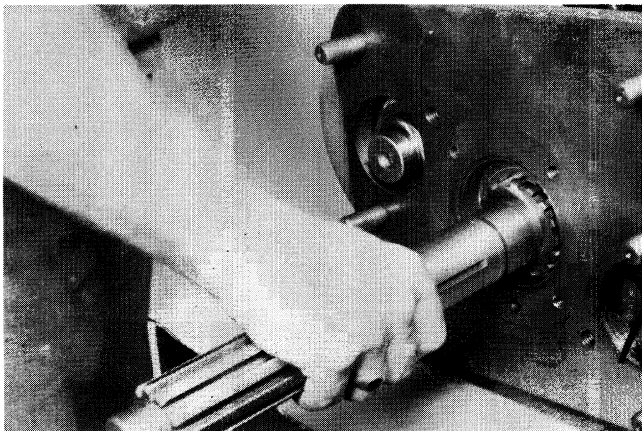

2. Insert the clutch shaft into the drive gear.

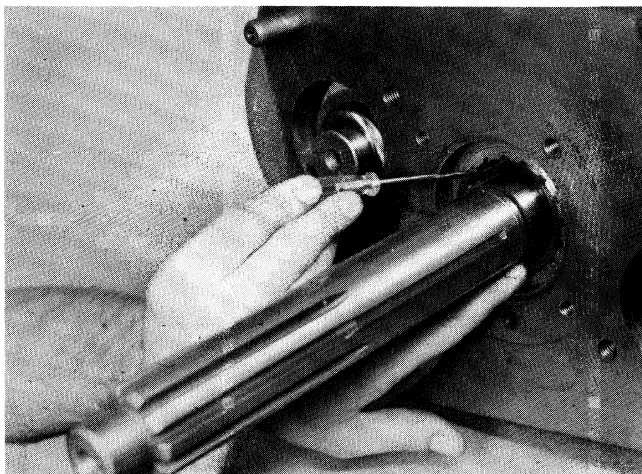

3. Install the snap ring in the inner diameter of the drive gear.

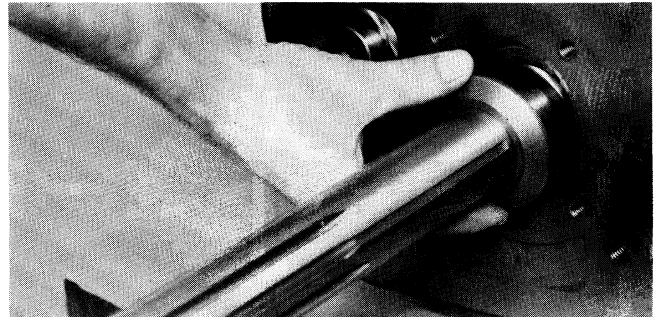

4. Install the spacer on the shaft, flat side against the gear.

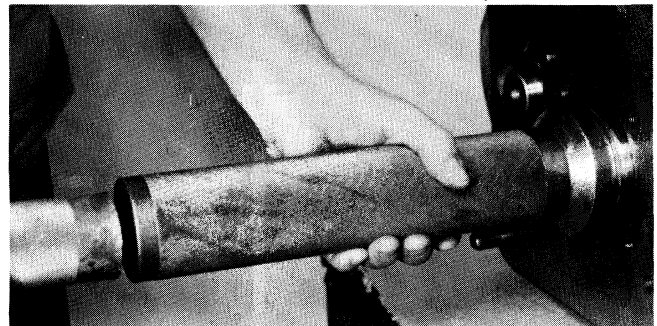

5. Install the drive gear bearing on the shaft and in the case bore.

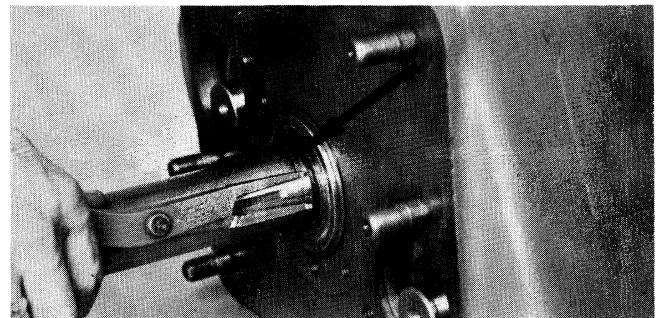

6. Install the snap ring in the groove in the shaft, flat side towards the bearing.

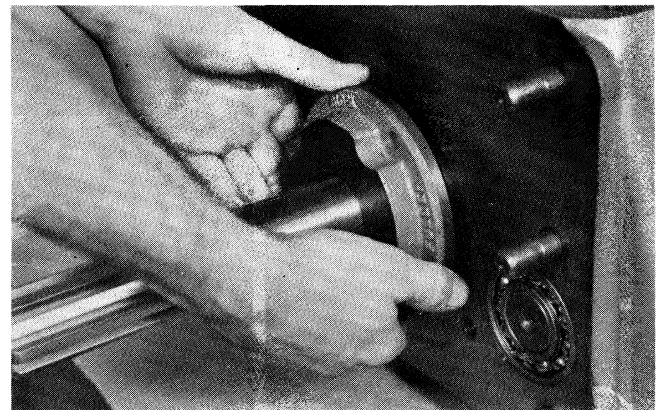

7. Install the front bearing cover or upshift clutch brake.

**F. Installation of the Right Countershaft Bearings**

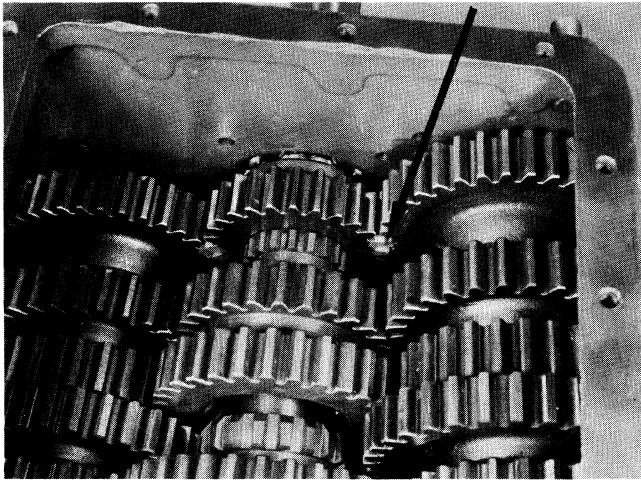

1. Engage the timing tooth on the right countershaft between the two marked teeth on the drive gear, ensuring that the left countershaft is still in time.

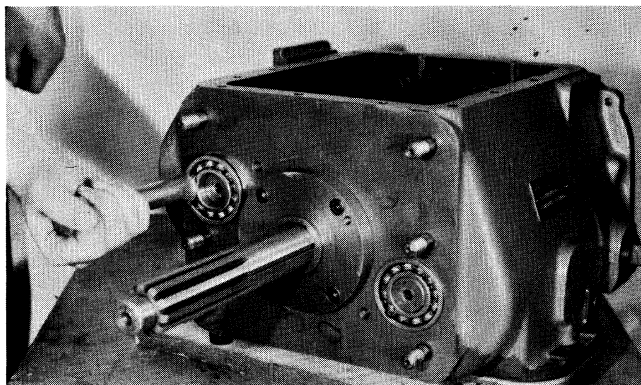

2. Center the rear of the shaft in the bore and partially install the front bearing. Partially install the rear bearing.

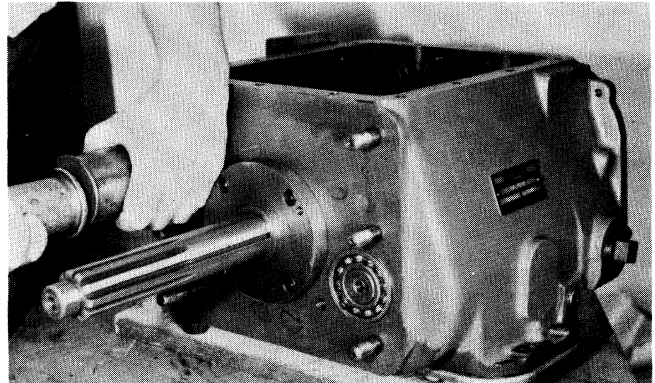

3. Use a bearing driver to complete the installation of the bearings.

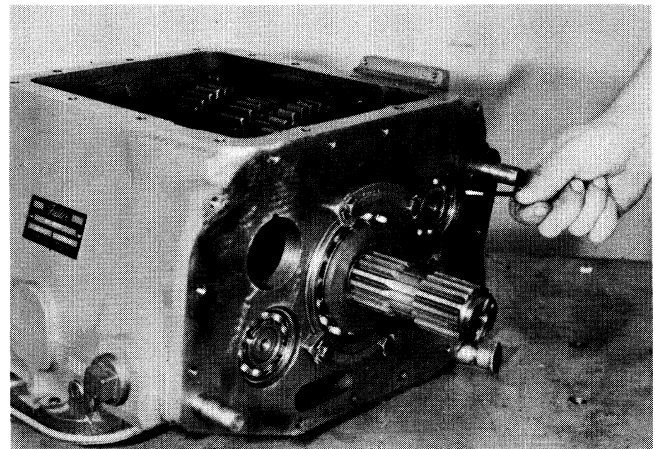

4. Install the snap ring in the groove in the rear counter shaft bearing bore. Drive both countershafts back until the rear bearings seat against the snap rings.

**G. Installation of the Left Reverse Idler Gear**

1. The left reverse idler gear is installed in the same manner as the right, as both are identical. Refer to page 50.

## II. AUXILIARY INTERMEDIATE HOUSING

### A. Reassembly of the Auxiliary Drive Gear/Clutch Gear Assembly

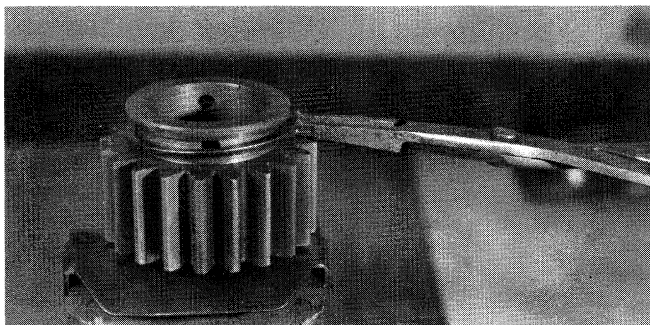

1. If previously removed, install the snap ring on the drive gear, large diameter facing out.

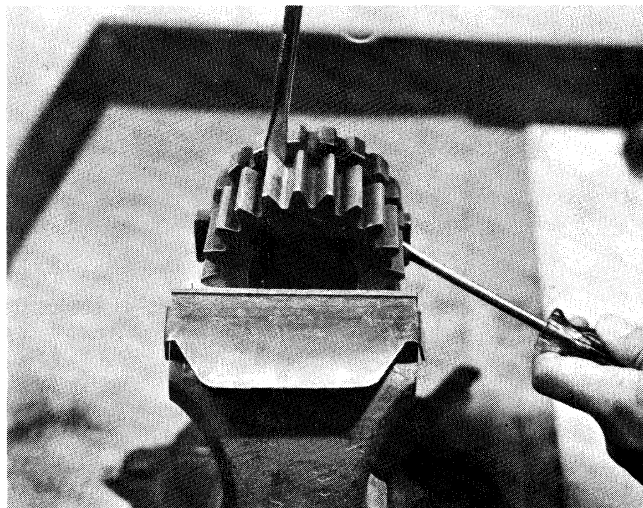

3. Use two screwdrivers to pry the snap ring into position inside the clutch gear.

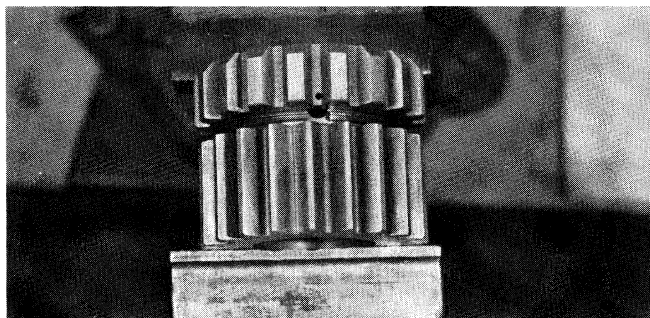

2. Place the small diameter of the drive gear inside the clutch gear and mount the assembly in a vise so that the two gears are forced together. For ease in installation of the retaining pin, place the snap ring so that the open section is underneath the retaining pin hole.

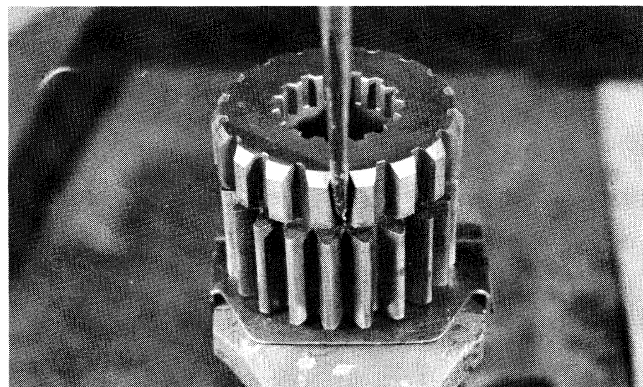

4. Align one of the holes in the drive gear with the retaining pin hole and insert the pin from inside the drive gear into place in the pin hole with the elbow bend facing away from the clutch gear. Turn the drive gear so the pin cannot fall out. Use a hammer and punch to bend the end of the retaining pin down in between the teeth of the clutch gear.



**B. Reassembly of the Intermediate Section**

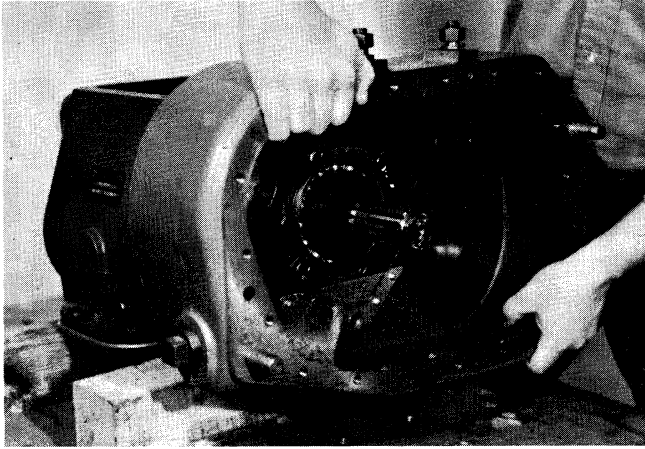

1. Place the intermediate housing on the dowel pins and against the front case.

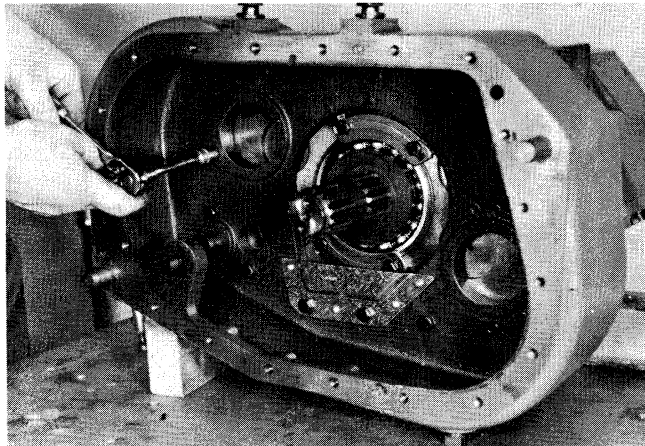

2. Secure the intermediate housing to the front case with 13 cap screws (9 short, 4 long.) **DO NOT** install cap screws in the two top center holes.

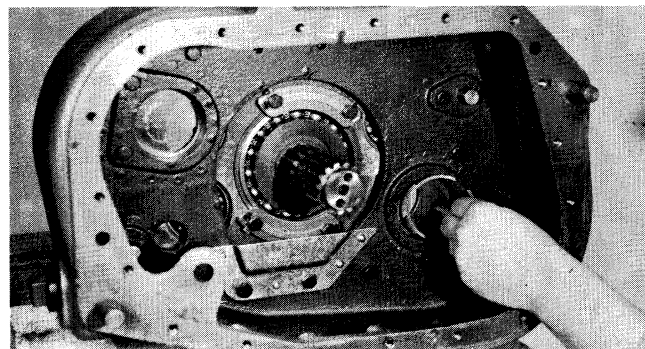

3. Place a snap ring spacer in both front auxiliary counter-shaft bearing bores.

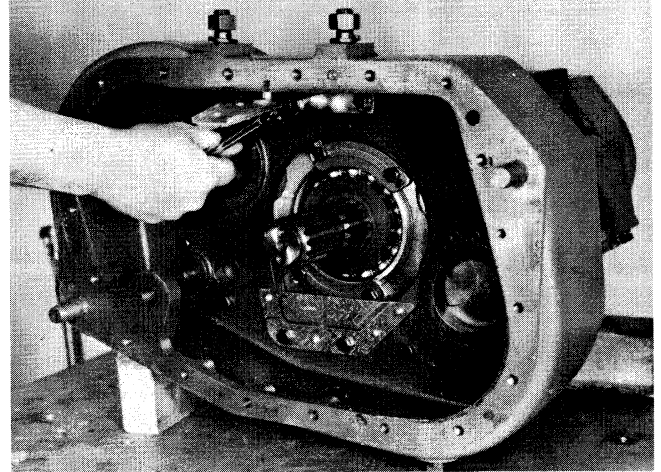

4. Install the metal oil trough in the intermediate housing with two cap screws in the front wall and one cap screw in the top of the housing. The spacer is placed between the oil trough and the top of case.

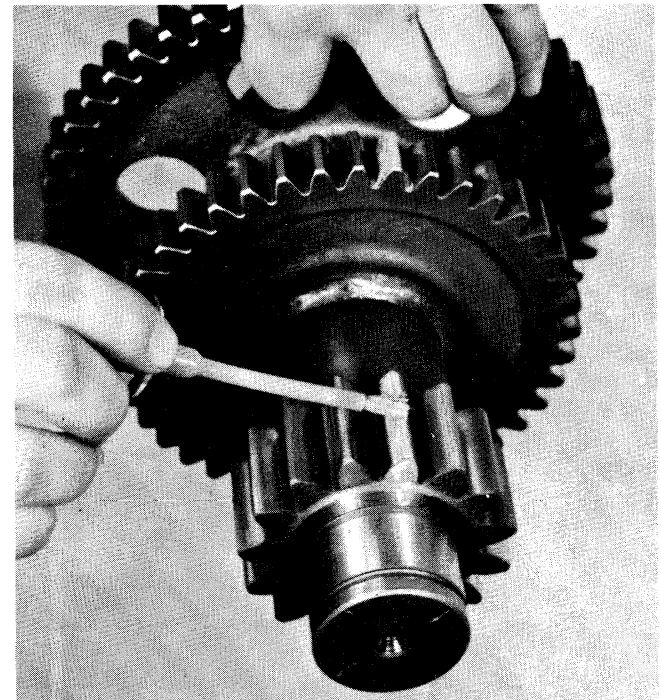

5. **IMPORTANT:** Mark the low speed gear tooth identified with an "O" on each auxiliary countershaft for timing purposes. Then mark the tooth on the intermediate and drive gears which align with this tooth. If previously removed, install the bearing on the front of each countershaft, seating against the shaft shoulder.



## REASSEMBLY – AUXILIARY INTERMEDIATE HOUSING

### B. Reassembly of the Intermediate Section – Continued

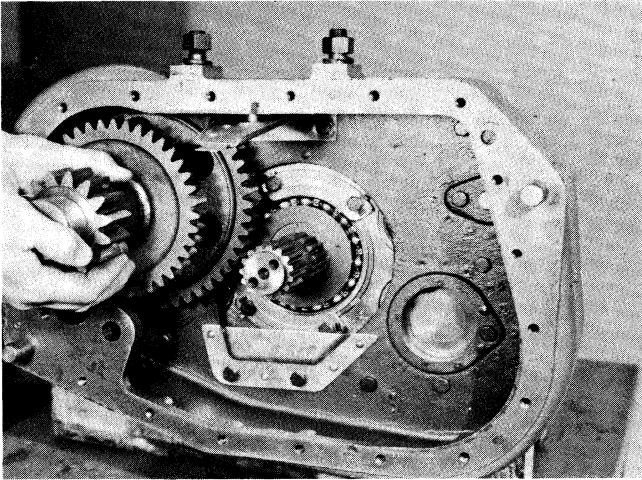

6. Place the left countershaft into position, but do not completely seat the front bearing in the bore.

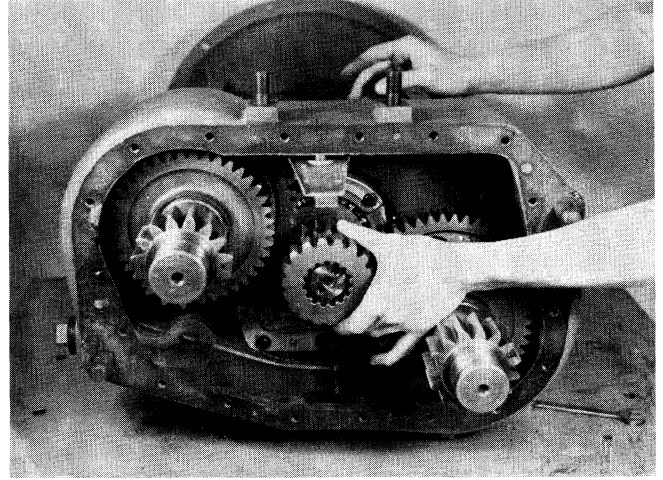

9. Install the auxiliary drive gear and sliding clutch assembly on the splines of the mainshaft, aligning both sections with the splines. Mesh the marked tooth on each countershaft between the marked teeth of the auxiliary drive gear.

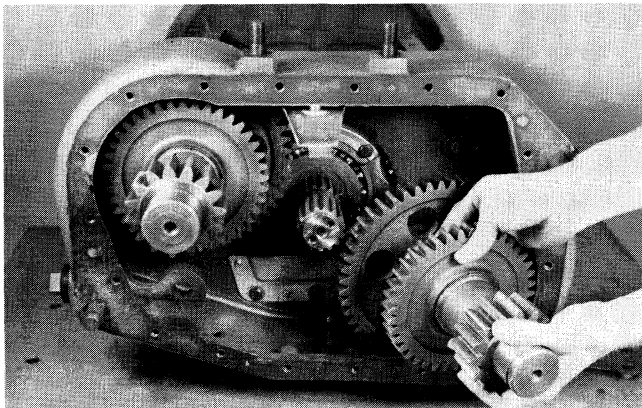

7. Place the right countershaft into position, but do not completely seat the front bearing in the bore.

NOTE: Keep the marked teeth on the countershafts parallel.

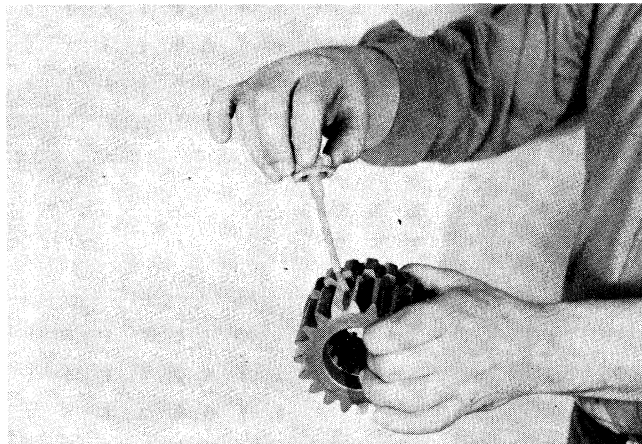

8. On the auxiliary drive gear and sliding clutch assembly mark two adjacent teeth on the drive (larger width) gear and mark the two teeth directly opposite.

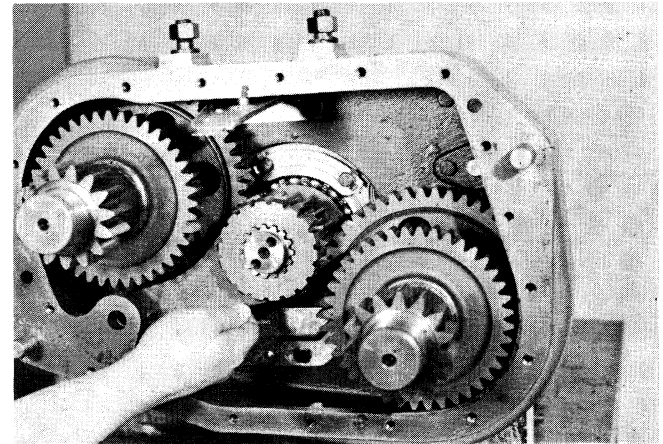

10. Place the intermediate shift yoke in the yoke slot of the auxiliary drive gear/sliding clutch assembly, hub to the rear.

## REASSEMBLY – AUXILIARY INTERMEDIATE HOUSING

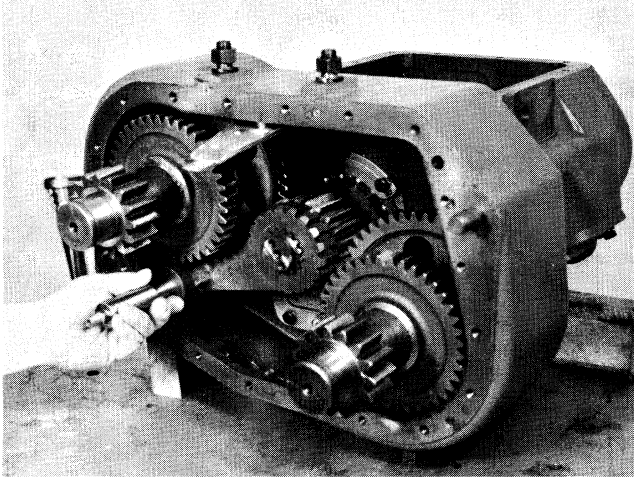

11. Install the intermediate shift shaft through the bore in the housing and the yoke hub. Secure with the lock-screw and wire.

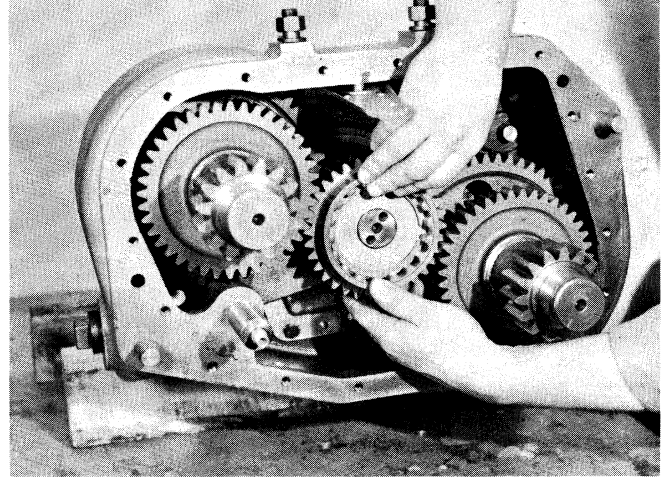

13. Place the drive gear on the rear of the mainshaft, meshing the marked tooth on each countershaft between the marked teeth on the drive gear.

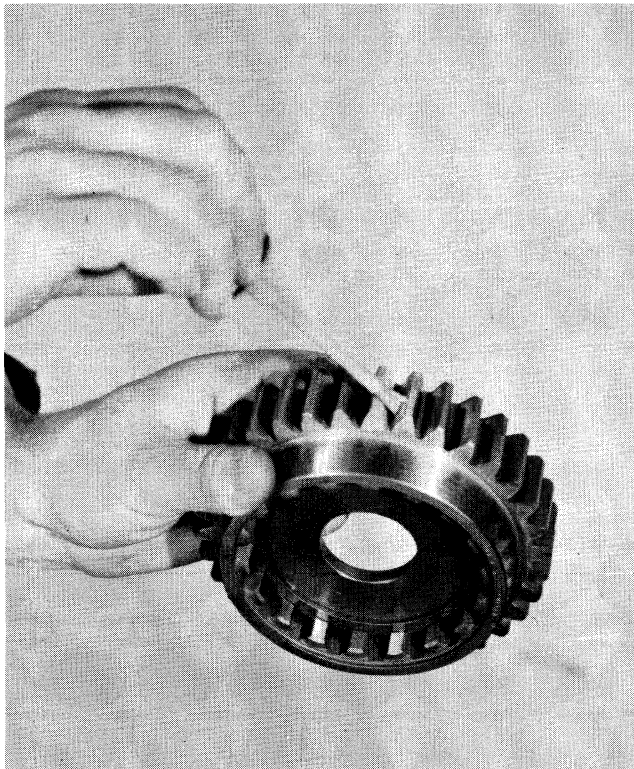

12. If previously removed, install the snap ring, plate, and second snap ring in the inner diameter of the intermediate drive gear, noting that the raised side of the plate faces towards the clutching teeth of the drive gear. Mark two adjacent teeth on the gear and the two teeth directly opposite.

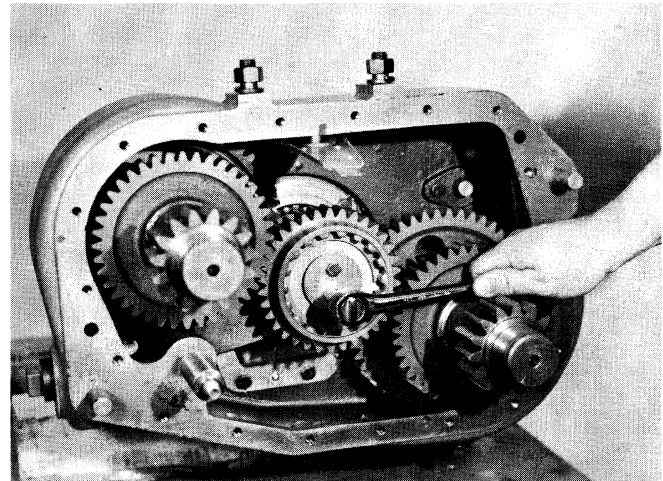

14. Install the retaining plate on the rear of the mainshaft with the two capscrews. Tighten and wire the capscrews securely.

### III. AUXILIARY REAR HOUSING

#### A. Reassembly of the Tailshaft and Rear Bearing Assembly

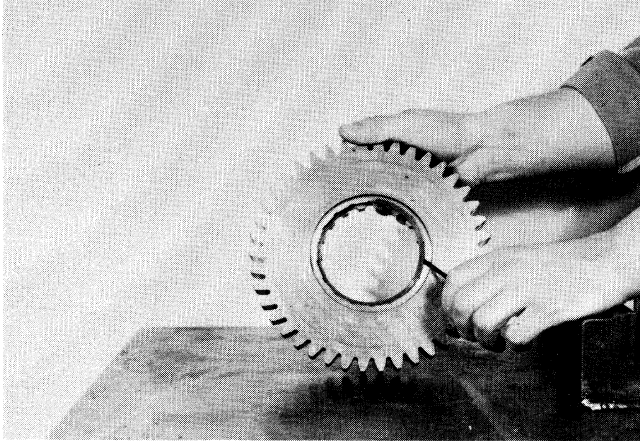

1. If previously removed, install the snap ring in the low speed gear.

**IMPORTANT:** For timing purposes, mark two adjacent teeth on the low speed gear and mark the two teeth directly opposite.

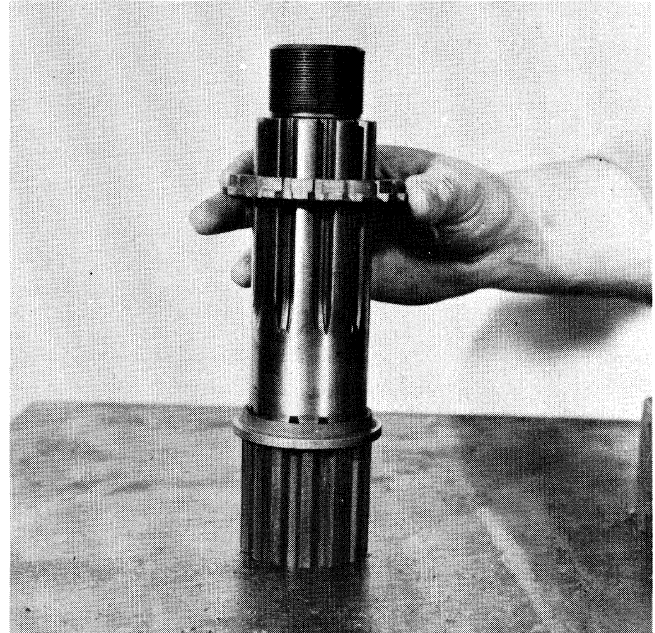

3. Install the splined spacer onto the shaft and washer.

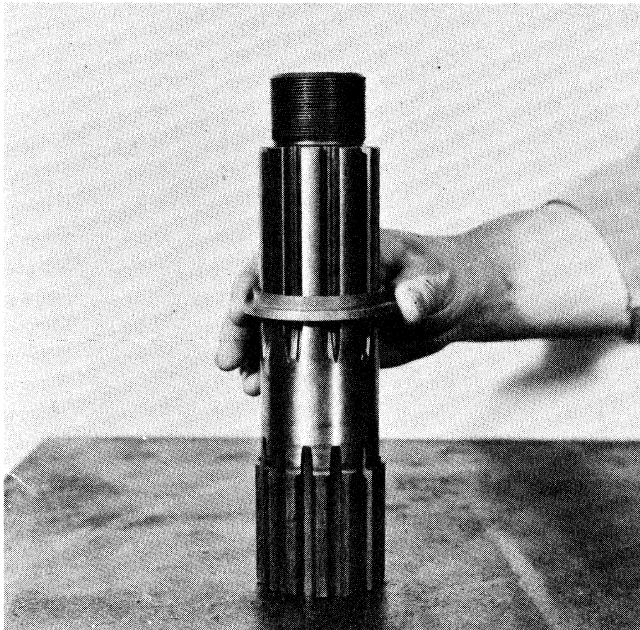

2. Set the tailshaft on a bench with the threaded end up and install the low speed gear stepped washer, large diameter down.

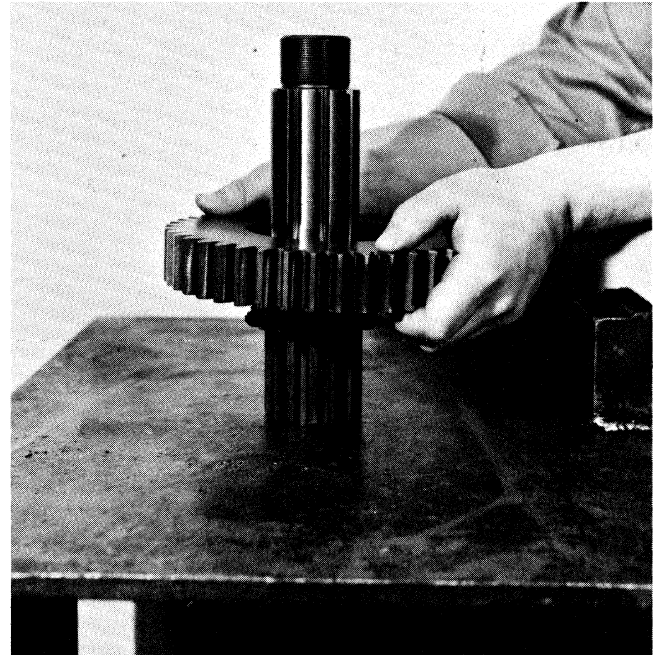

4. Install the low speed gear on the splined spacer, clutching teeth down.



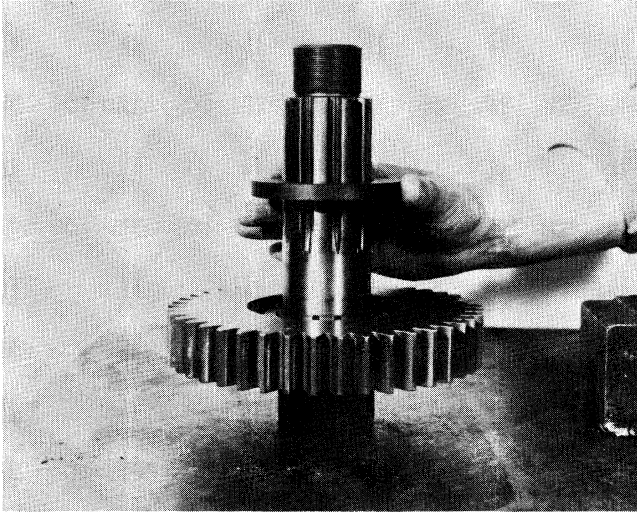

5. Install the low speed gear rear washer on the shaft, chamfered ID up.

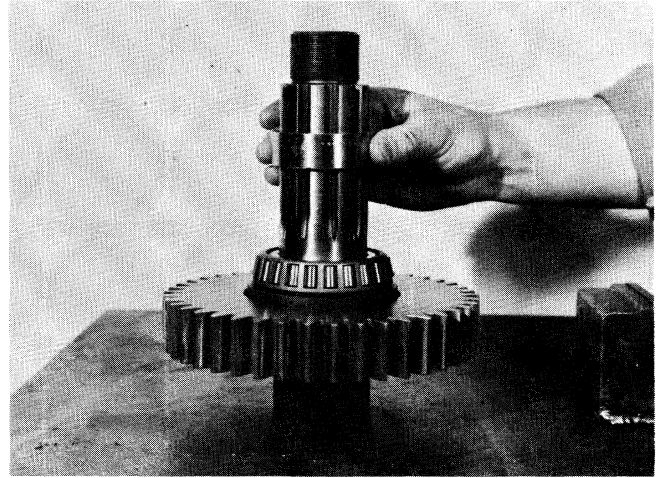

7. Install the bearing inner spacer on the shaft.

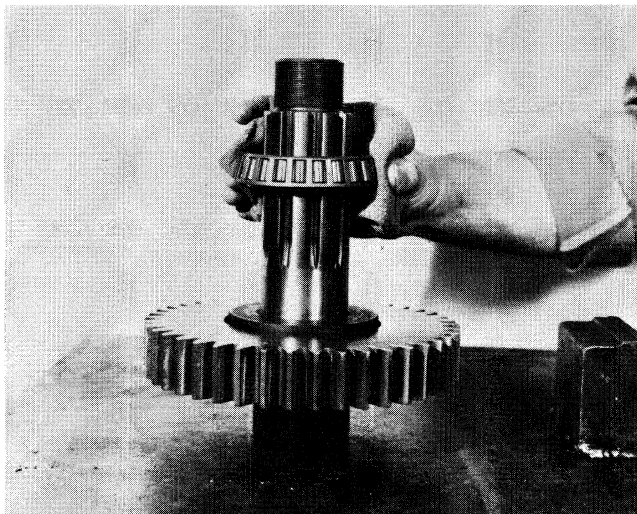

6. Install the front cone of the rear bearing on the shaft and against the washer. (Heating of the bearing will facilitate installation. Use heat lamps but do not heat over 275° F.)

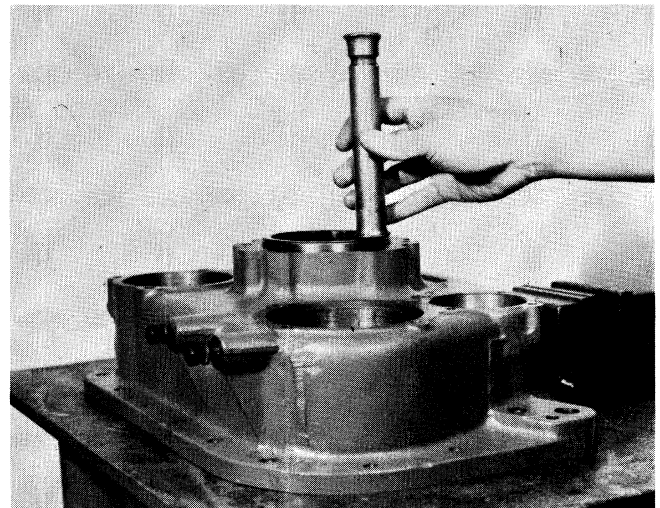

8. Place the front bearing cup partially into the bore of the housing, taper to the inside.

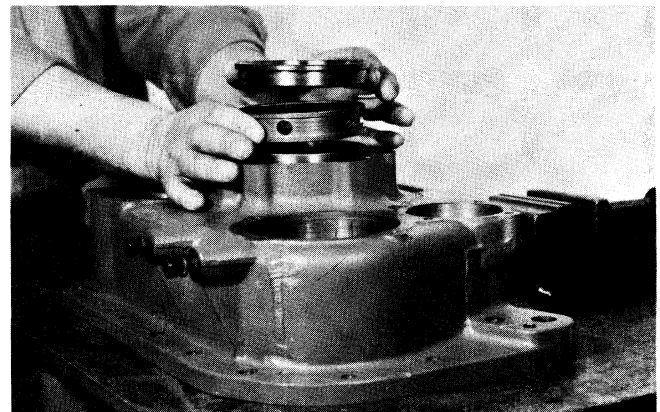

9. Place the bearing outer spacer on the front cup and place the rear bearing cup on the spacer.

## REASSEMBLY – AUXILIARY REAR HOUSING

### A. Reassembly of the Tailshaft and Rear Bearing Assembly – Continued

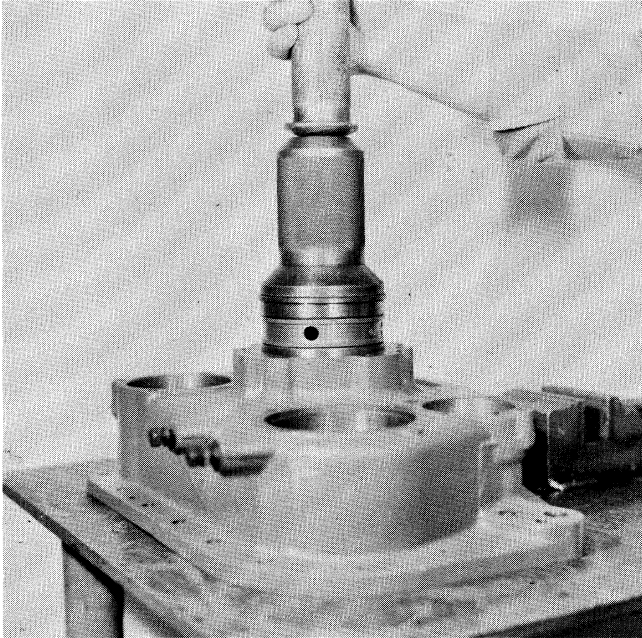

10. Tap all three units evenly into the rear bore until the lip of the rear cup seats against the housing.

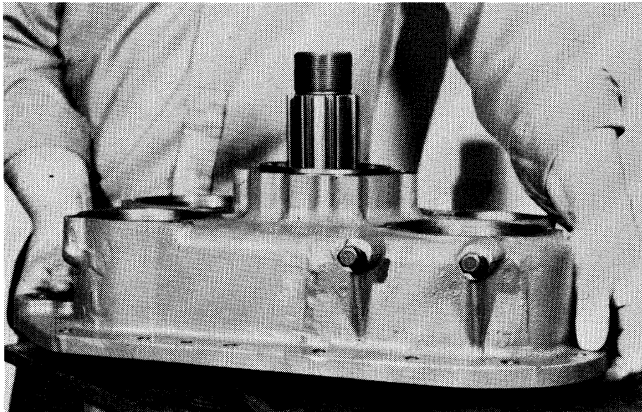

11. Place the auxiliary rear housing over the end of the shaft and seat the front bearing cone in the front cup.

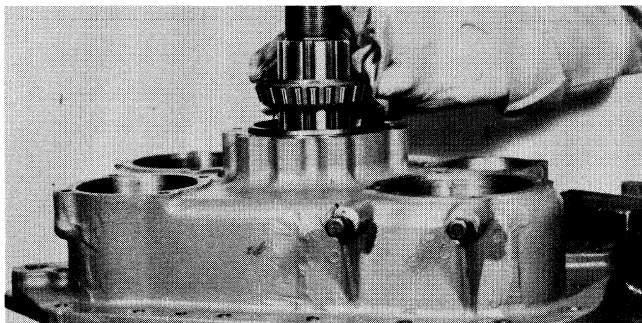

12. Install the bearing rear cone on shaft and into the rear cup. (Heating of the bearing cone will facilitate installation, but do not heat over 275° F.)

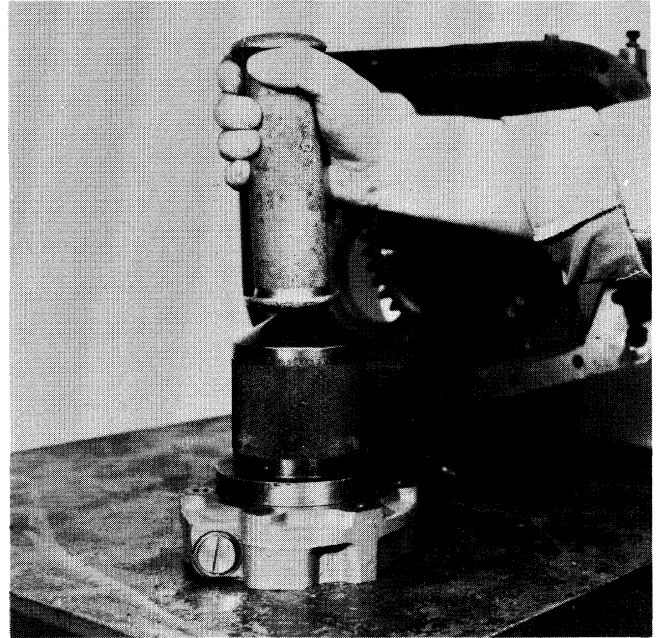

13. Install the oil seal in the rear bearing cover.

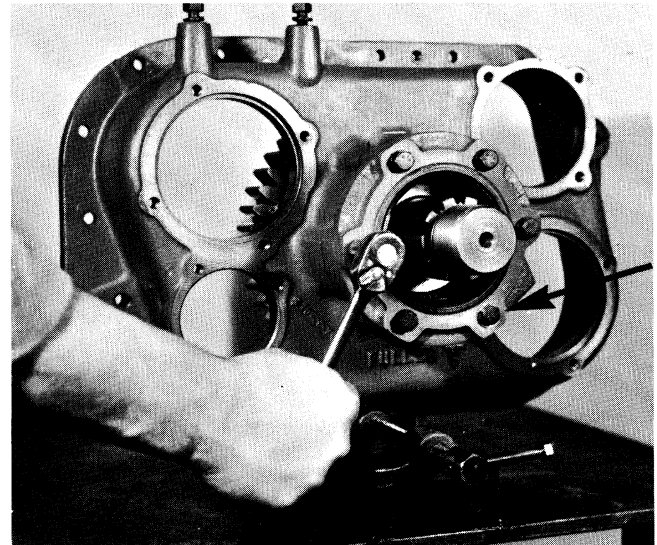

14. Install the rear bearing cover, using a brass washer at the speedometer gear location.



**B. Reassembly and Installation of the Synchronizer Assembly**

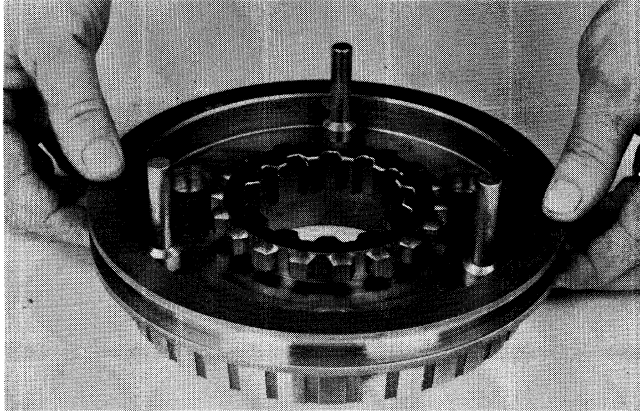

1. Install the sliding clutch on the pins of the low speed synchronizer, recessed side up.

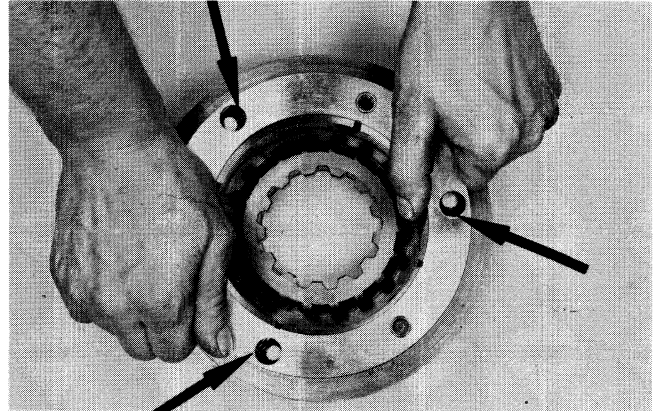

4. Compress the springs to fully seat the direct synchronizer on the pins of the low speed synchronizer.

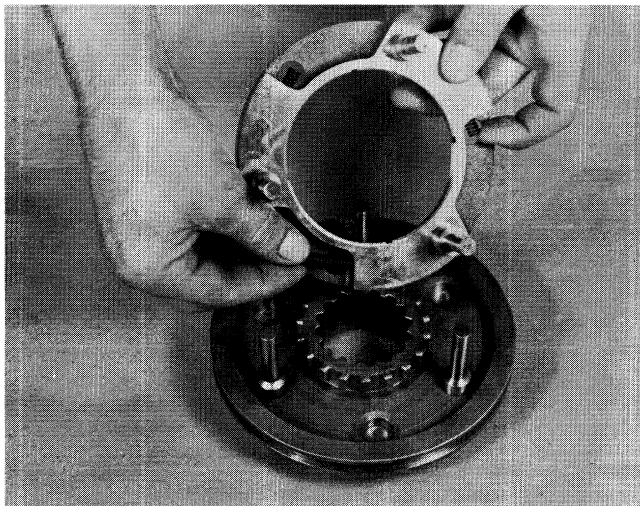

2. Install the three springs in the direct synchronizer.

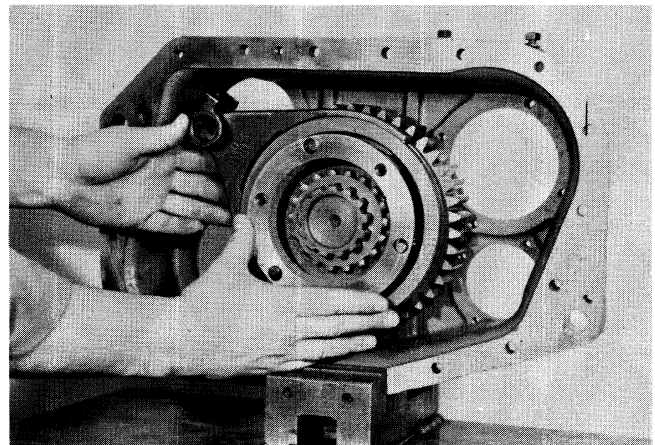

5. Place the direct-low shift fork into the yoke slot of the sliding clutch, short hub to the rear, and install the synchronizer assembly on the splines of the output shaft.

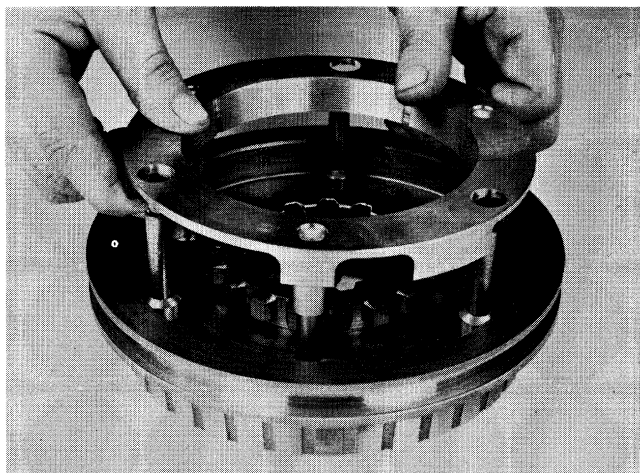

3. Place the direct synchronizer over the low speed blocker pins, seating the springs against the pins.

## REASSEMBLY – AUXILIARY REAR HOUSING

### C. Reassembly and Installation of the Auxiliary Shift Cylinder

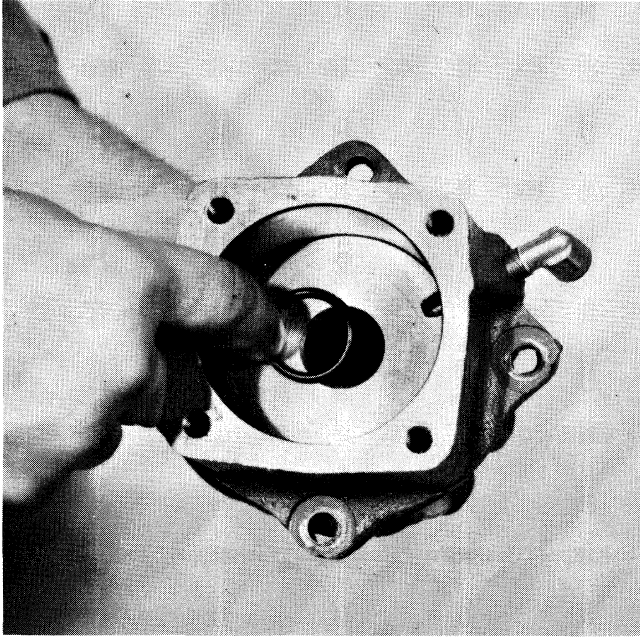

1. Install the O-ring in the bore of the shift cylinder.

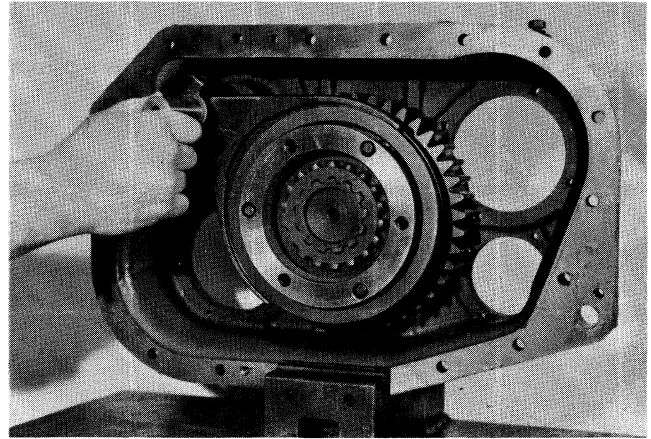

3. Install the shifting shaft from the front through the yoke hub and cylinder, aligning the notches with the lock-screw bores in the yoke hub.

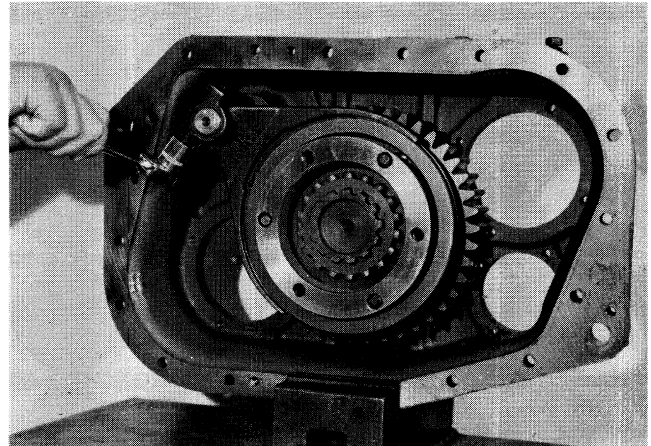

4. Install the two yoke lockscrews, tighten and wire securely.

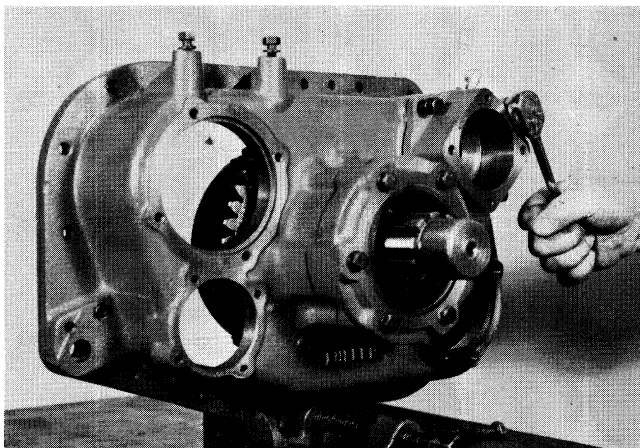

2. Install the cylinder housing into the rear housing bore and secure with four capscrews, noting that the air fitting is on the top right of the housing.

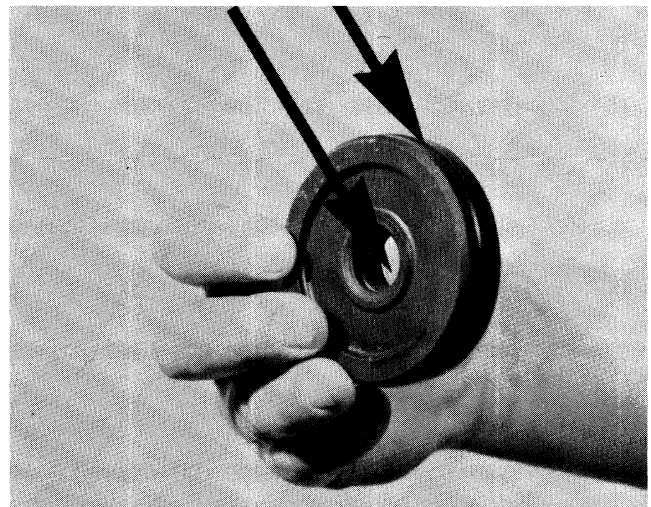

5. Install O-rings in the OD and ID of the piston.

## REASSEMBLY – AUXILIARY REAR HOUSING

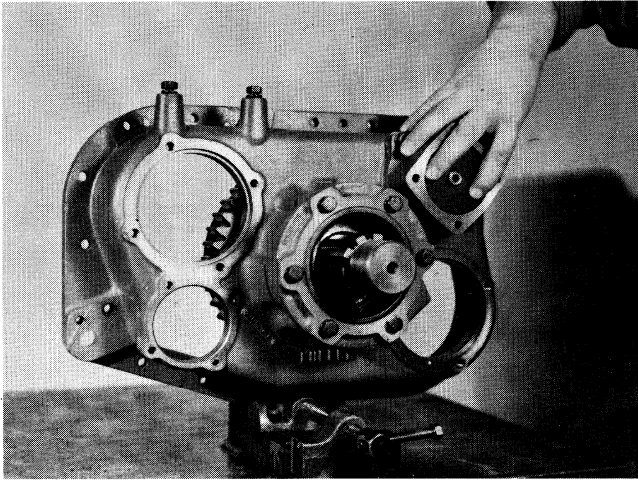

6. Install the piston on the shifting shaft, flat side out.

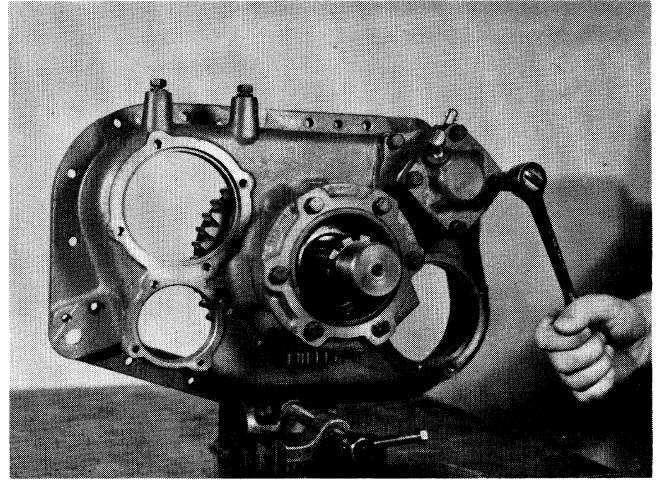

8. Install the shift cylinder cover with four cap screws, noting that the air fitting is on the top left side.

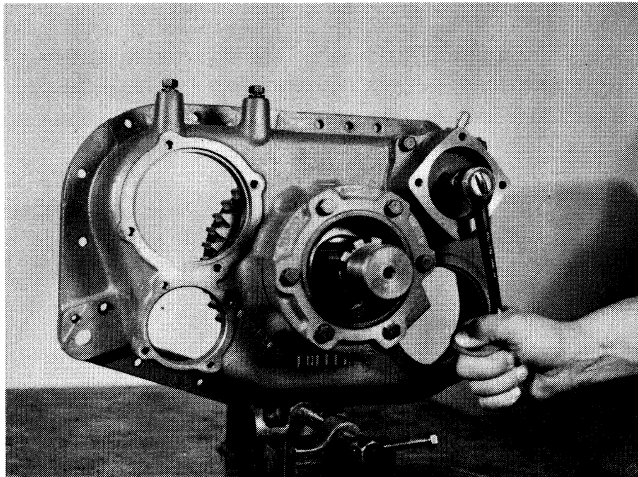

7. Install the locknut on the shifting shaft.



## REASSEMBLY – AUXILIARY REAR HOUSING

### D. Installation of the Auxiliary Rear Housing

NOTE: Make sure that prior to installation the synchronizer assembly is as far forward as possible on the tailshaft and that the marked teeth on the auxiliary countershafts are facing each other.

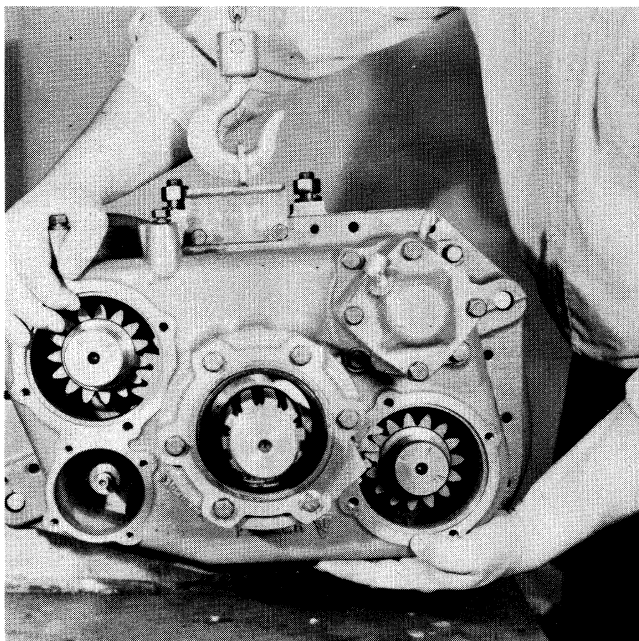

1. Using a hoist, move the rear housing up to the intermediate housing and start the rear housing into position with the top tipped back slightly to allow the synchronizer assembly to pass between the auxiliary countershafts. Check the synchronizer occasionally to make sure that the direct synchronizer is not sliding off the low speed blocker pins. Look through the rear bearing bores and mesh the marked tooth on each countershaft between the two marked teeth on each side of the auxiliary low speed gear. Move the rear housing evenly onto the two dowel pins, using caution to prevent damage to the oil trough.

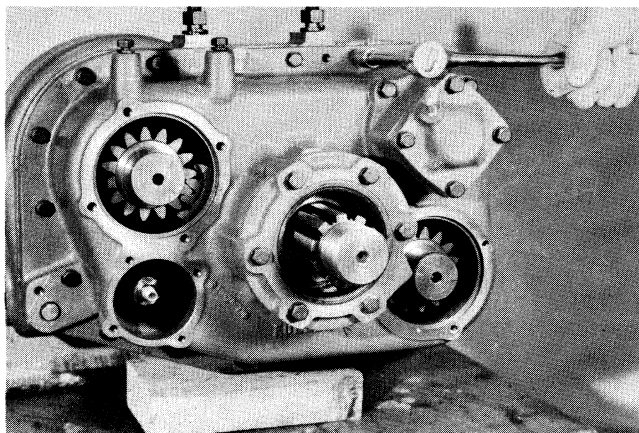

2. Secure the rear housing with the retaining capscrews.

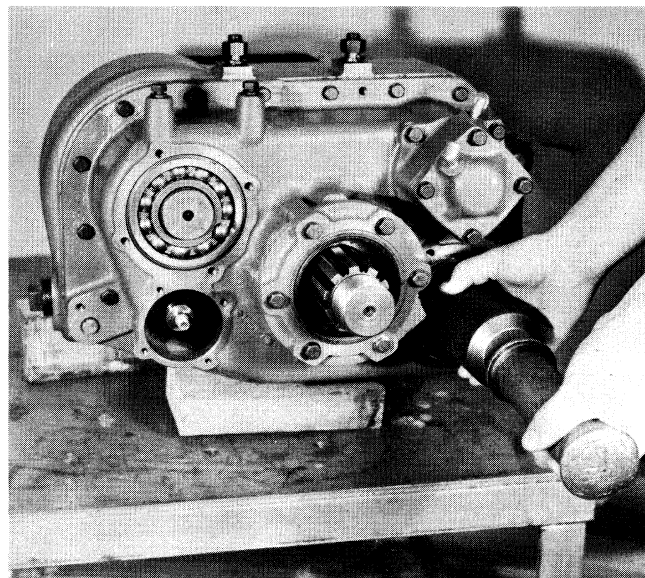

3. Use a soft bar and mallet against the rear of both auxiliary countershafts to seat the front bearings and use a bearing driver to install the rear bearings on the shafts and in the bores.

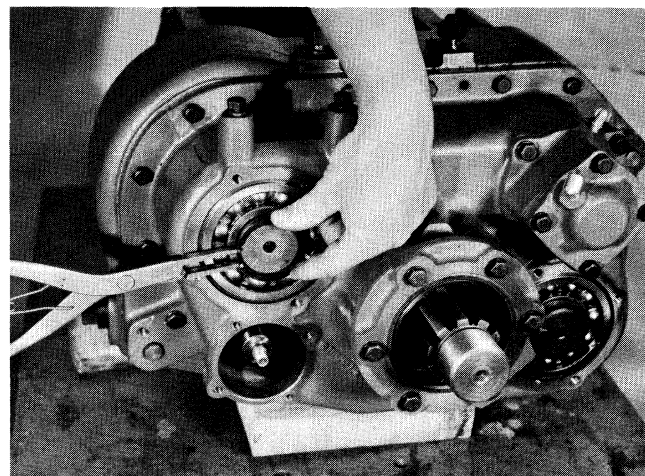

4. Install the rear bearing retaining snap rings in the countershaft grooves.



## REASSEMBLY – AUXILIARY REAR HOUSING

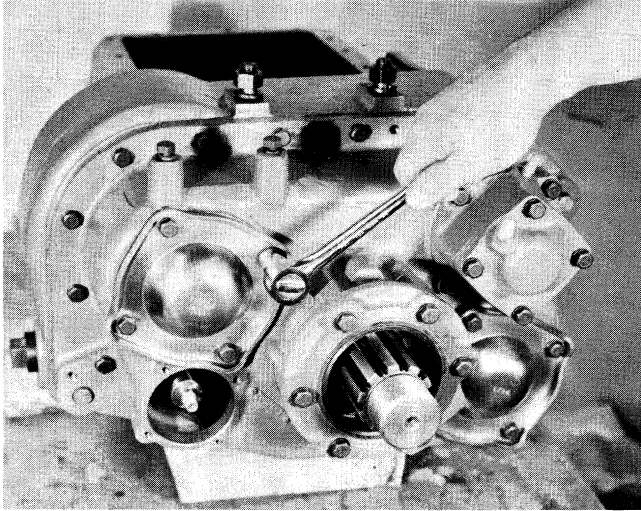

5. Install the rear bearing covers.

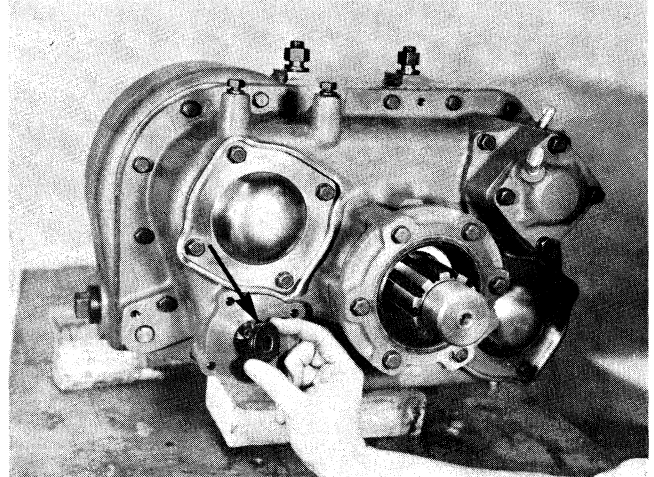

8. Install the O-ring on the outer diameter of the piston and install the piston on the shaft in the cylinder.

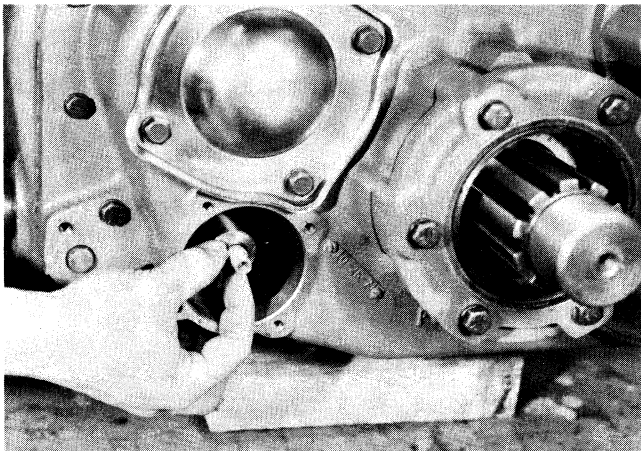

6. Install the O-ring on the intermediate shift shaft.

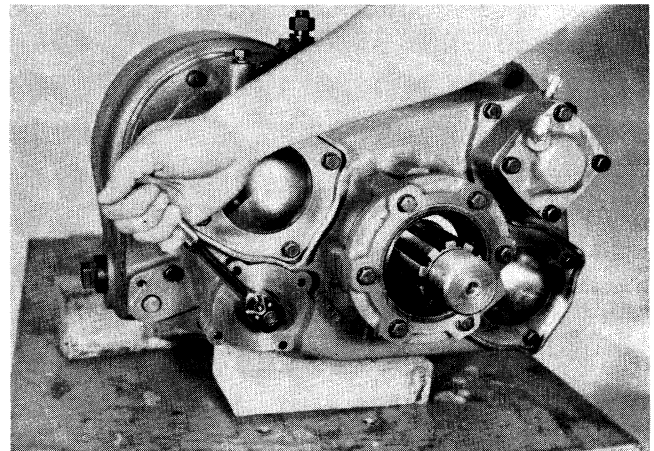

9. Install the elastic stop nut on the shift shaft.

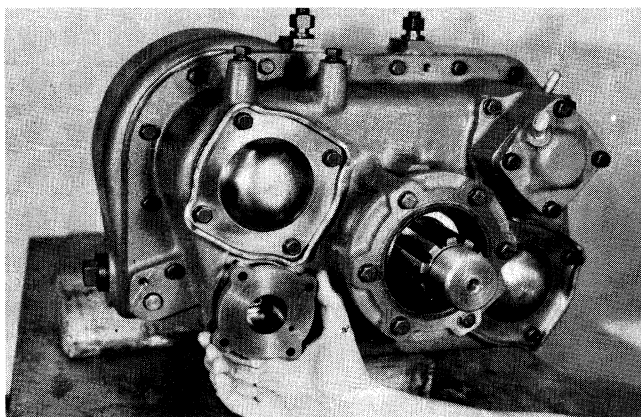

7. Install the intermediate shift cylinder in the rear housing, fitting the shift shaft through the cylinder bore. Cylinder is installed with the small air channel in the housing to the right.

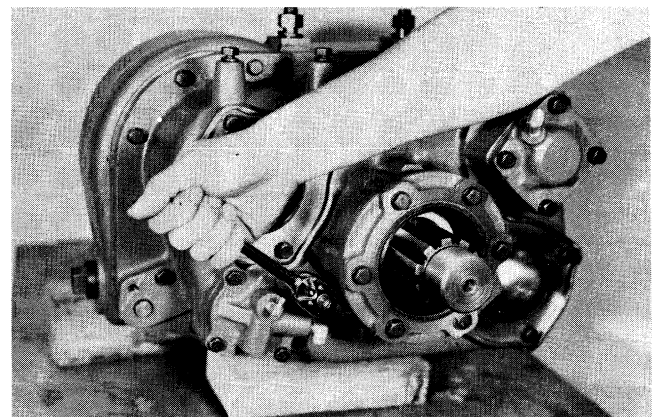

10. Install the shift cylinder cover, aligning the small air channel on the cover with the channel in the housing. The insert valve opening on the cover will be facing down.

**D. Installation of the Auxiliary Rear Housing – Continued**

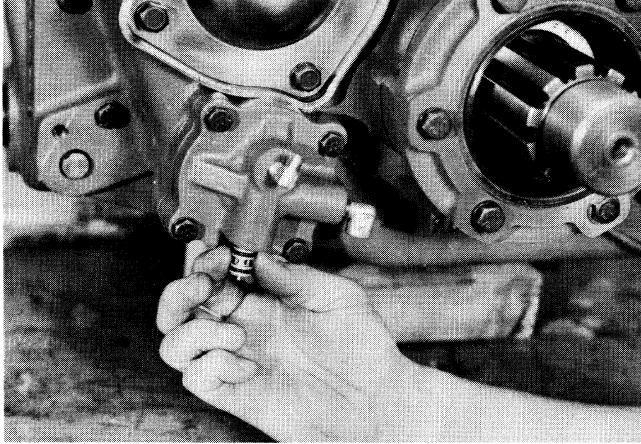

11. If previously removed, install the insert valve in the cover with the flat end facing up.

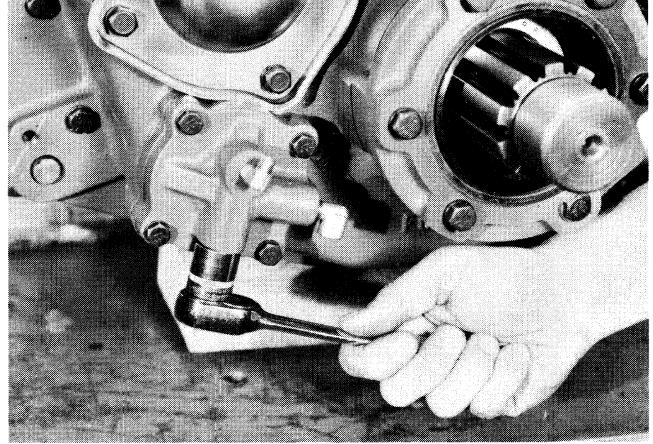

12. Install the insert valve retaining nut in the cover.

## IV. COMPANION FLANGE AND CLUTCH HOUSING

### A. Installation of the Clutch Housing

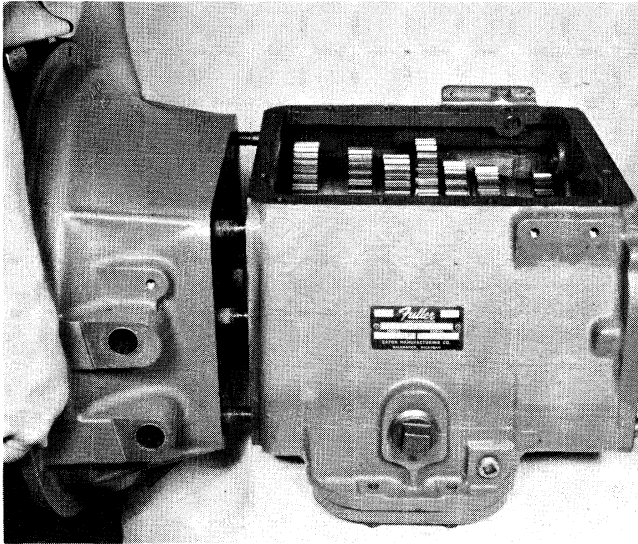

1. Install the clutch housing on the studs in the front case.

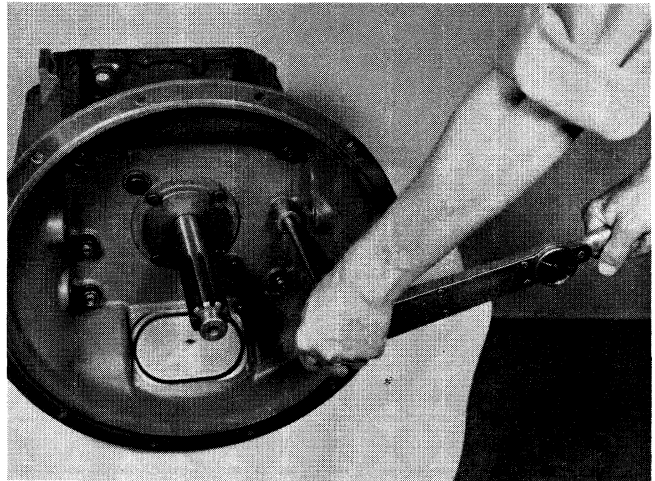

2. Install the washers and nuts on the studs and then install the washers and bolts, using the correct torque:

Nuts 170-185 ft./lbs.

Bolts 70- 75 ft./lbs.

### B. Installation of the Companion Flange

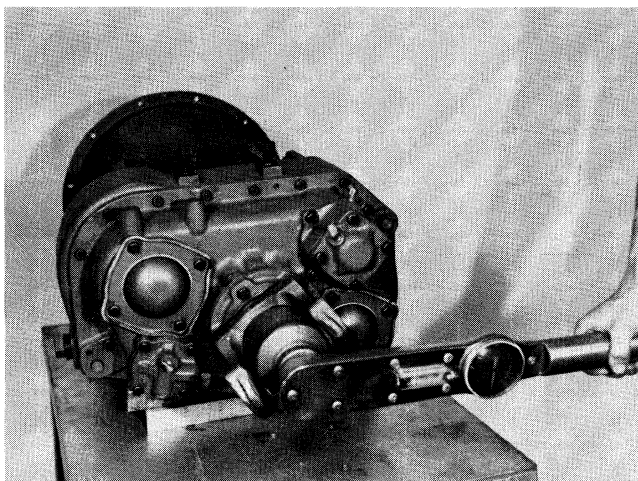

1. Install the speedometer drive gear or replacement spacer on the hub of the yoke or flange, lock the transmission in two speeds and install the yoke or flange on the splines of the tailshaft. Install the tailshaft nut and torque to 450-500 ft./lbs.



## V. SHIFTING CONTROLS

### A. Reassembly and Installation of the Shift Bar Housing

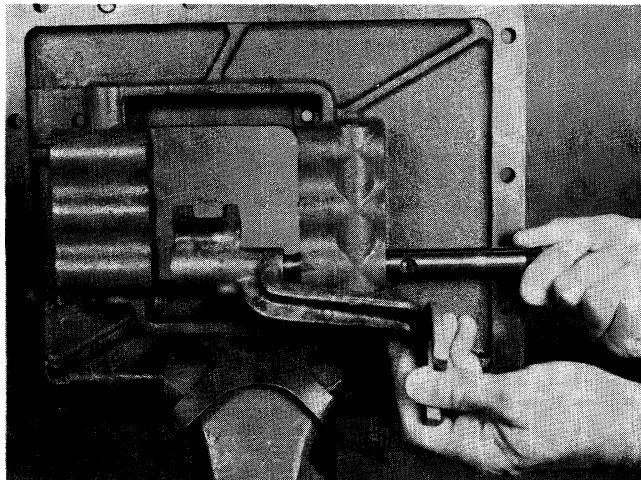

1. Install the 4th-5th speed shift bar and yoke. Install the yoke lockscrew and tighten and wire securely. Keep the bar in the neutral position.

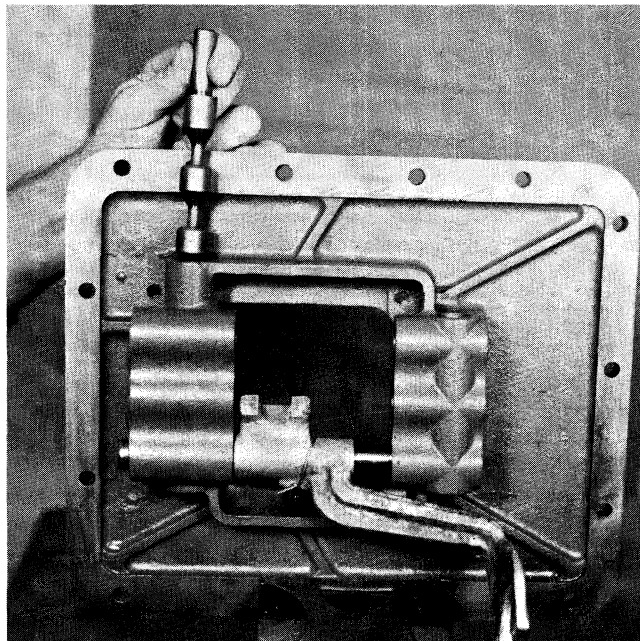

3. Install the actuating plunger in the rear web.

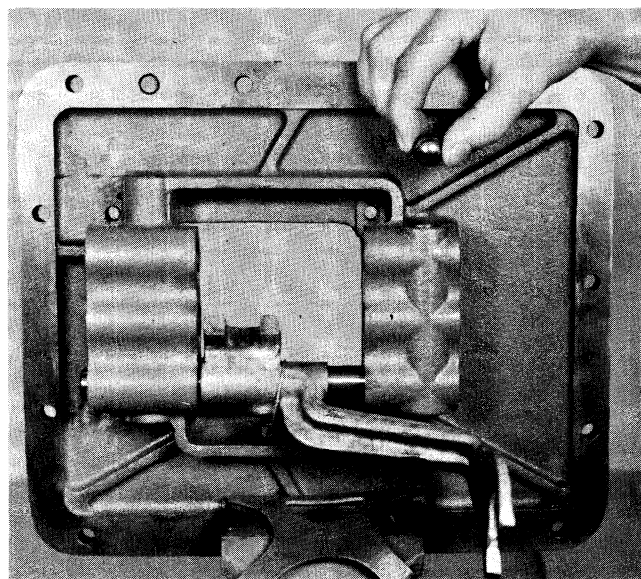

2. Install an interlock ball in the front web.

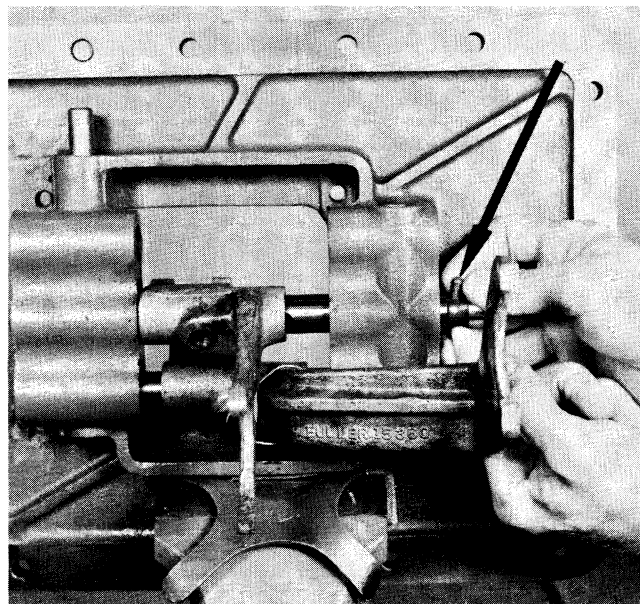

4. Install the 2nd-3rd speed shift bar and yoke, inserting the interlock pin in the bore of the neutral notch. Install the yoke lockscrew and tighten and wire securely.



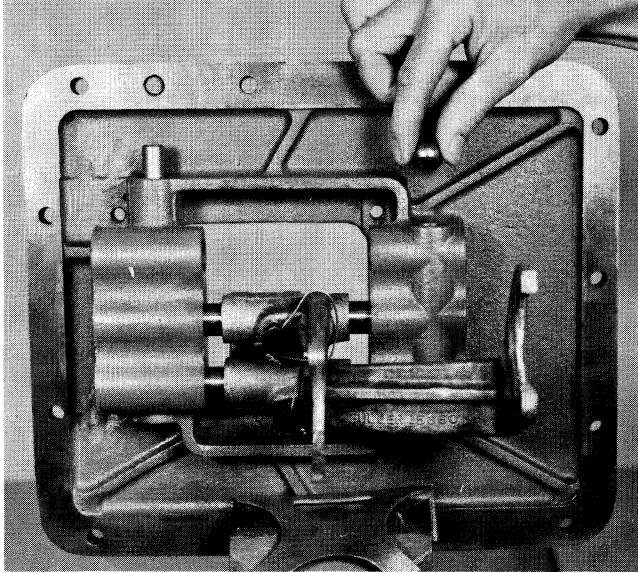

5. Install an interlock ball in the front web.

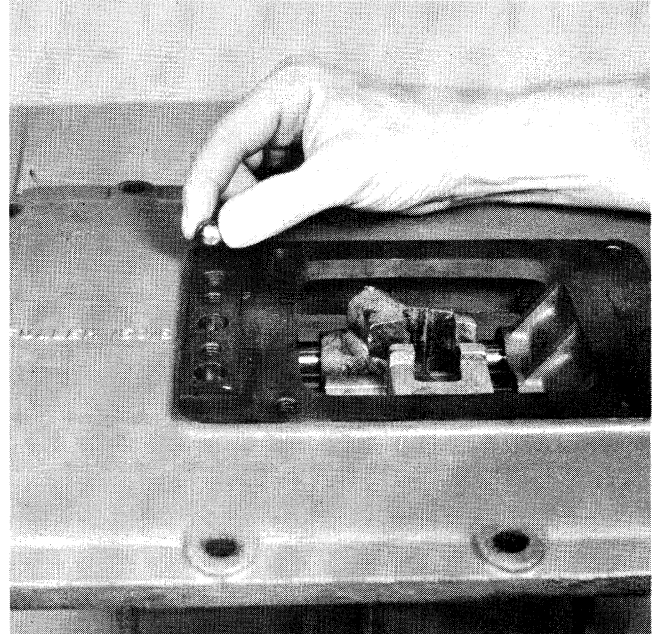

7. Remove the assembly from the vise and install the three tension balls, one in each bore in the top of the housing.

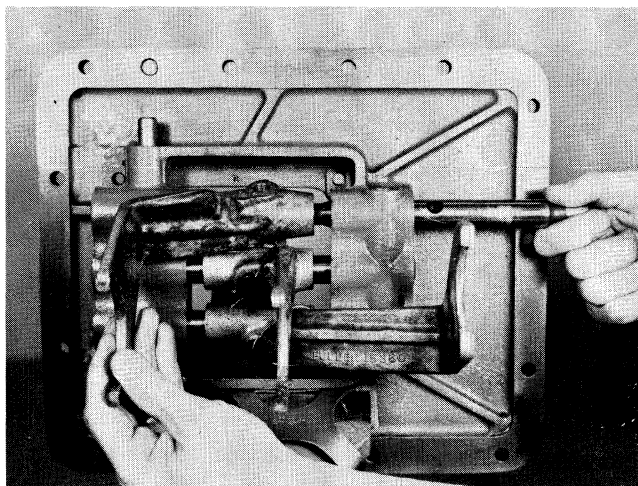

6. Install the 1st-reverse shift bar and yoke. Install the yoke lock screw and tighten and wire securely.

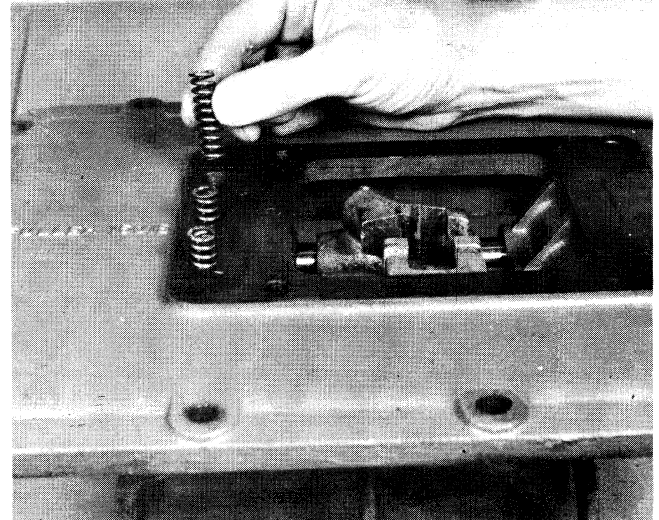

8. Install the tension springs on top of the balls in the bores.

## REASSEMBLY – SHIFTING CONTROLS

### A. Reassembly and Installation of the Shift Bar Housing – Continued

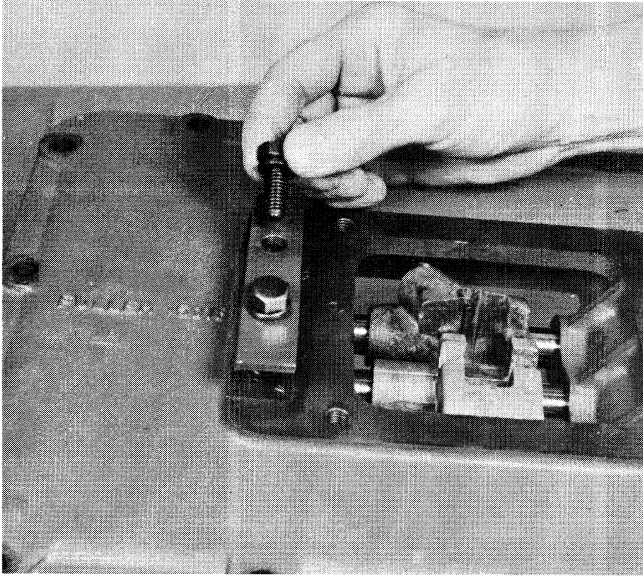

9. Install the tension spring cover and retain with the two capscrews.

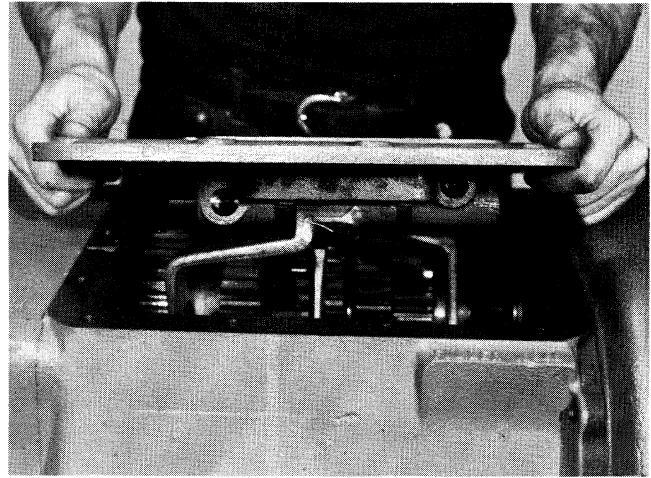

10. Check to make sure that the shift yokes and sliding clutches are in the neutral position and install the shift bar housing on the transmission, tension spring cover to the front and the yoke forks in the sliding clutches. Secure with the 13 capscrews.

**B. Reassembly and Installation of the Gear Shift Lever Housing**



1. If so equipped, install the O-ring in groove in the housing.

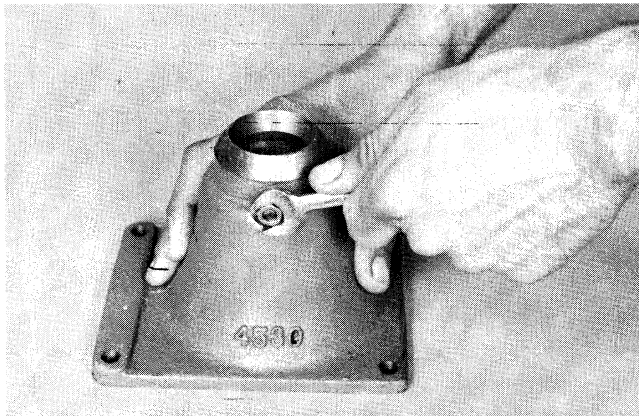

2. Install the lockwasher and nut to secure the pivot pin.

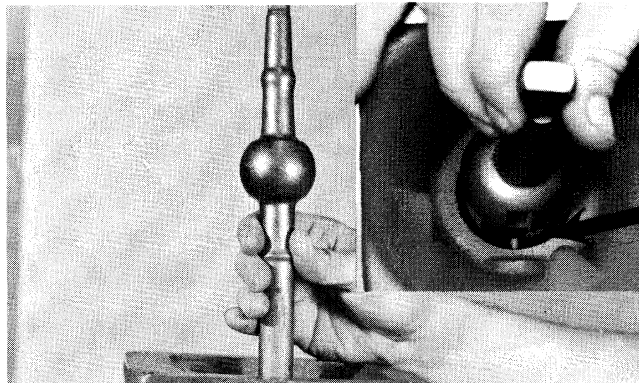

3. Install the gear shift lever in the housing, fitting the pivot pin in the slot in the lever.

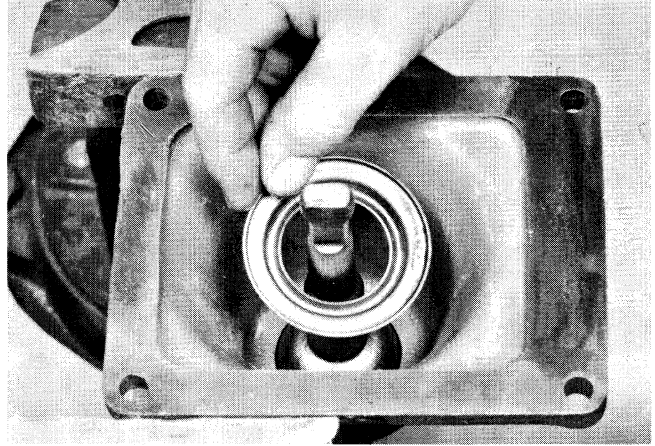

4. Install the tension spring washer in the housing.

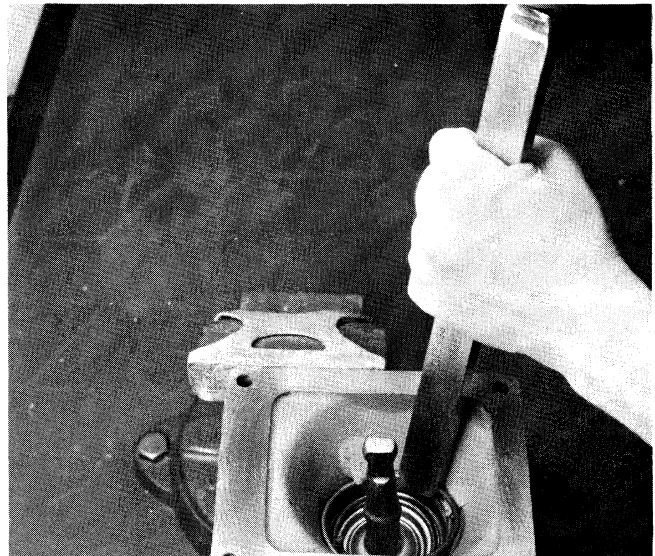

5. Seat the tension spring under the lugs in the housing.

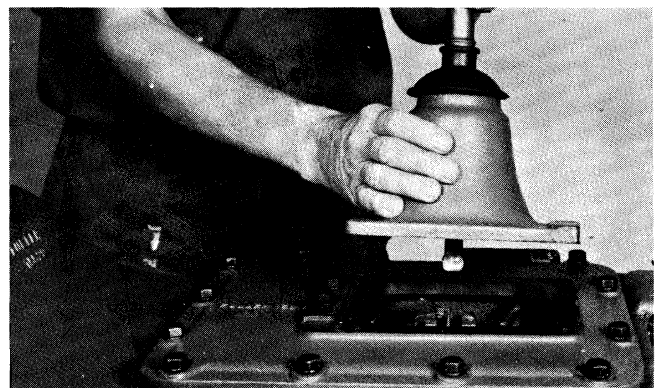

6. Check to make sure that the shift bar housing is in the neutral position and install the gear shift lever housing, fitting the lever into the shifting slots in the forks. Secure with four cap screws.



## REASSEMBLY – SHIFTING CONTROLS

### C. Installation of the Air System



1. Install the actuating pin and spring in the bore in the case.

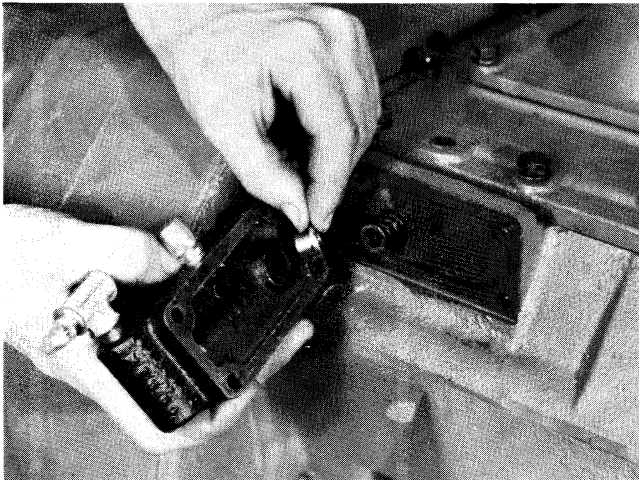

2. Install the hat-type alignment sleeve in the air valve.

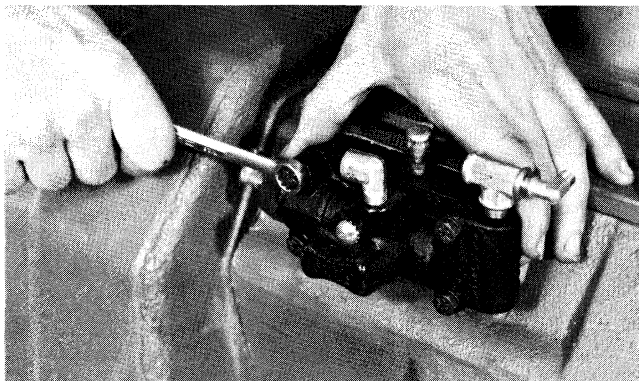

3. Install the air valve on the transmission, using air to move the piston all the way forward or to the rear before installing the air valve.

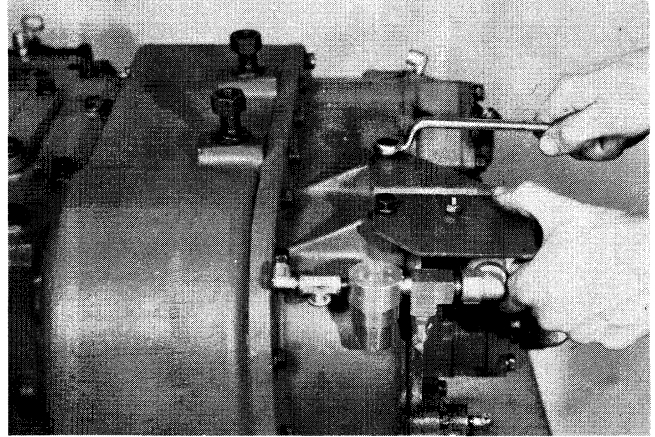

4. Attach the air filter/regulator assembly to the rear housing with the two retaining capscrews.

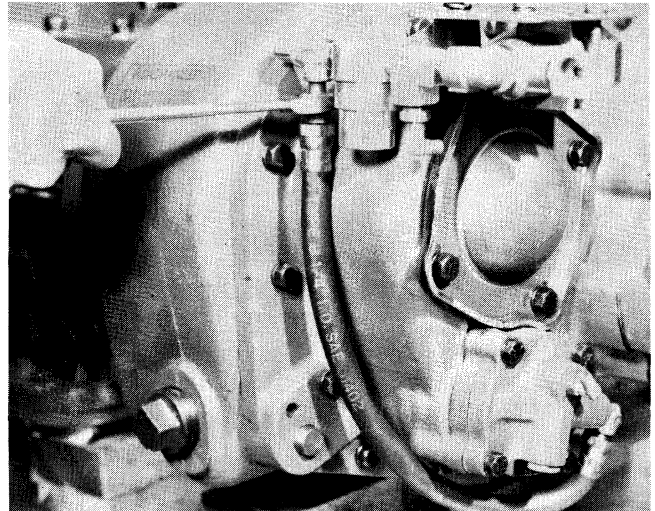

5. Connect the 1/4" air line between the intermediate shift cylinder and the air filter/regulator assembly.

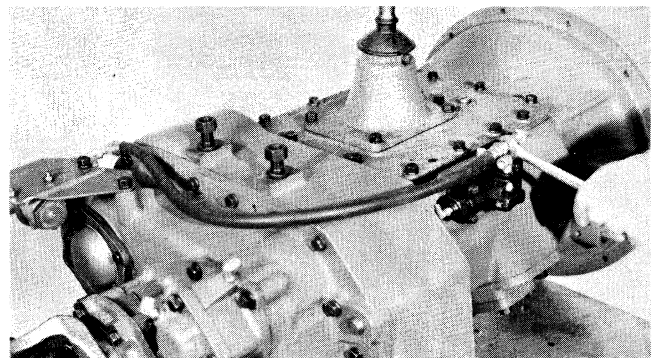

6. Connect the 1/4" ID air line between the air filter/regulator assembly and the rear port of the tee fitting on top of the air valve.



## REASSEMBLY – SHIFTING CONTROLS

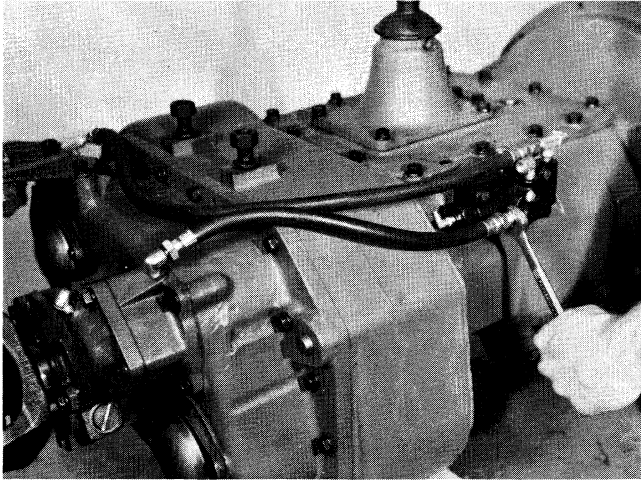

7. Connect the ¼" ID air line between the air valve and the low range port of the auxiliary shift cylinder.

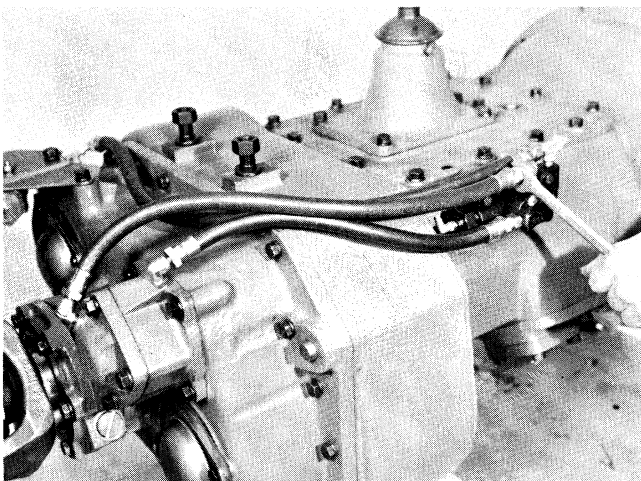

8. Connect the ¼" ID air line between the air valve and the direct range port of the auxiliary shift cylinder.

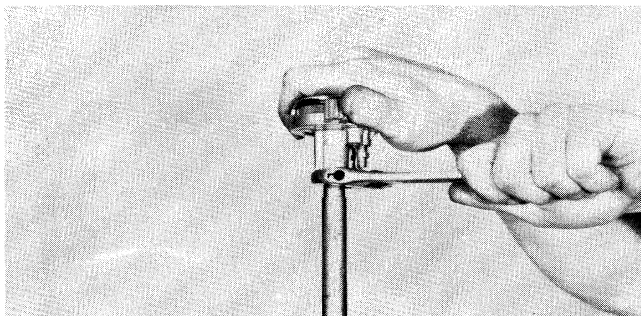

9. Install the ⅛" OD air lines, sheathing and O-rings on the shifting lever. Install the jam nut and control valve and back the jam nut up against the control valve to secure it in the desired position.

NOTE: To avoid confusion, only the air line being installed in each of the following three steps is shown attached to the control valve.

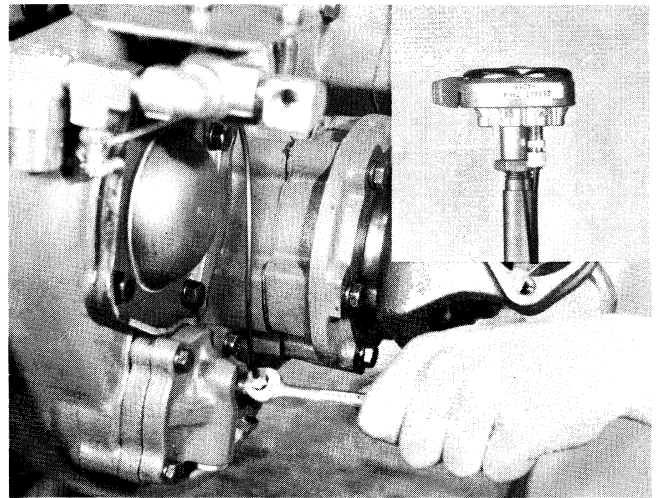

10. Connect the ⅛" OD long black air line between the intermediate shift cylinder and the port in the control valve identified with an "F". (See insert.)

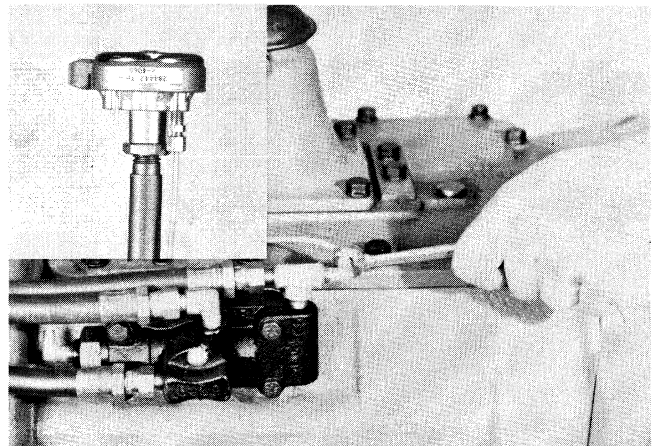

11. Connect the ⅛" OD white air line between the forward fitting on the slave air valve and the port in the control valve identified with an "S". (See insert.)

## REASSEMBLY – SHIFTING CONTROLS

### C. Installation of the Air System – Continued

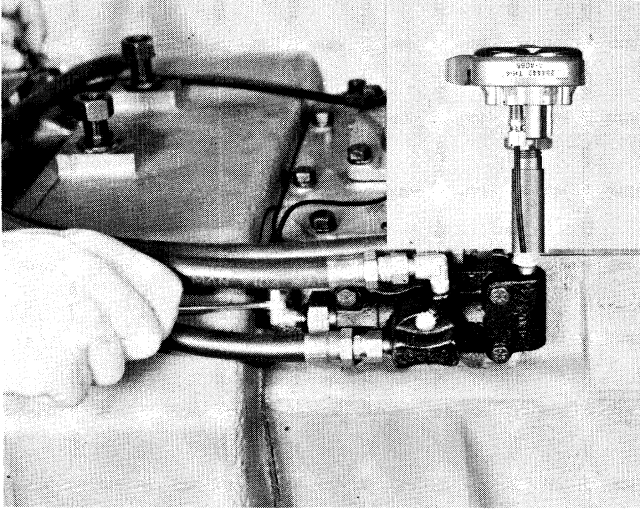

12. Connect the  $\frac{1}{8}$ " OD short black air line between the rear fitting on the slave air valve and the port in the control valve identified with an "R". (See insert.)

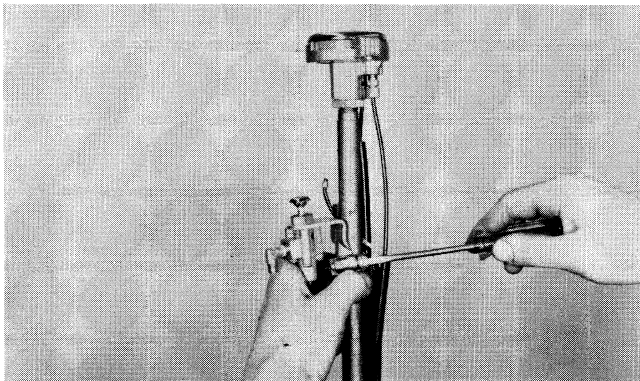

13. If so equipped, attach the countershaft brake control valve and clamp to the shift lever and secure the valve by tightening the screw on the clamp.

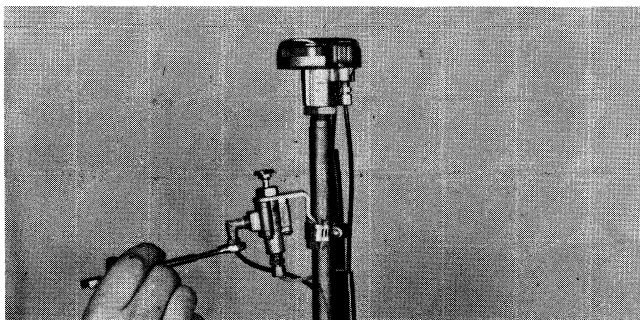

14. Attach the black  $\frac{1}{8}$ " OD brake control air line to the elbow fitting on the front of the valve and attach the white air line to the fitting on the bottom of the valve.

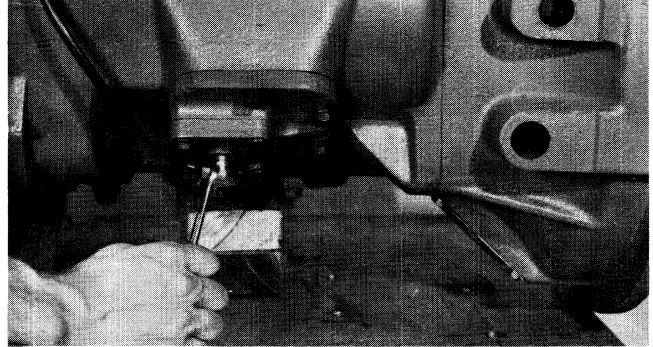

15. Attach the black  $\frac{1}{8}$ " OD air line to the TCB-6 countershaft brake located on the right PTO opening.

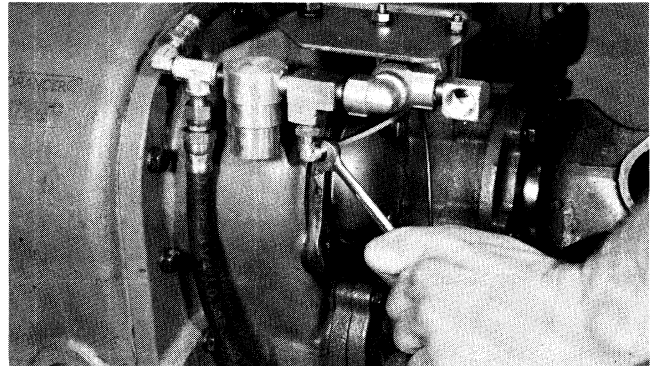

16. Attach the white  $\frac{1}{8}$ " OD air line to the tee block between the air filter and regulator.

RANGE SHIFT AIR SYSTEM

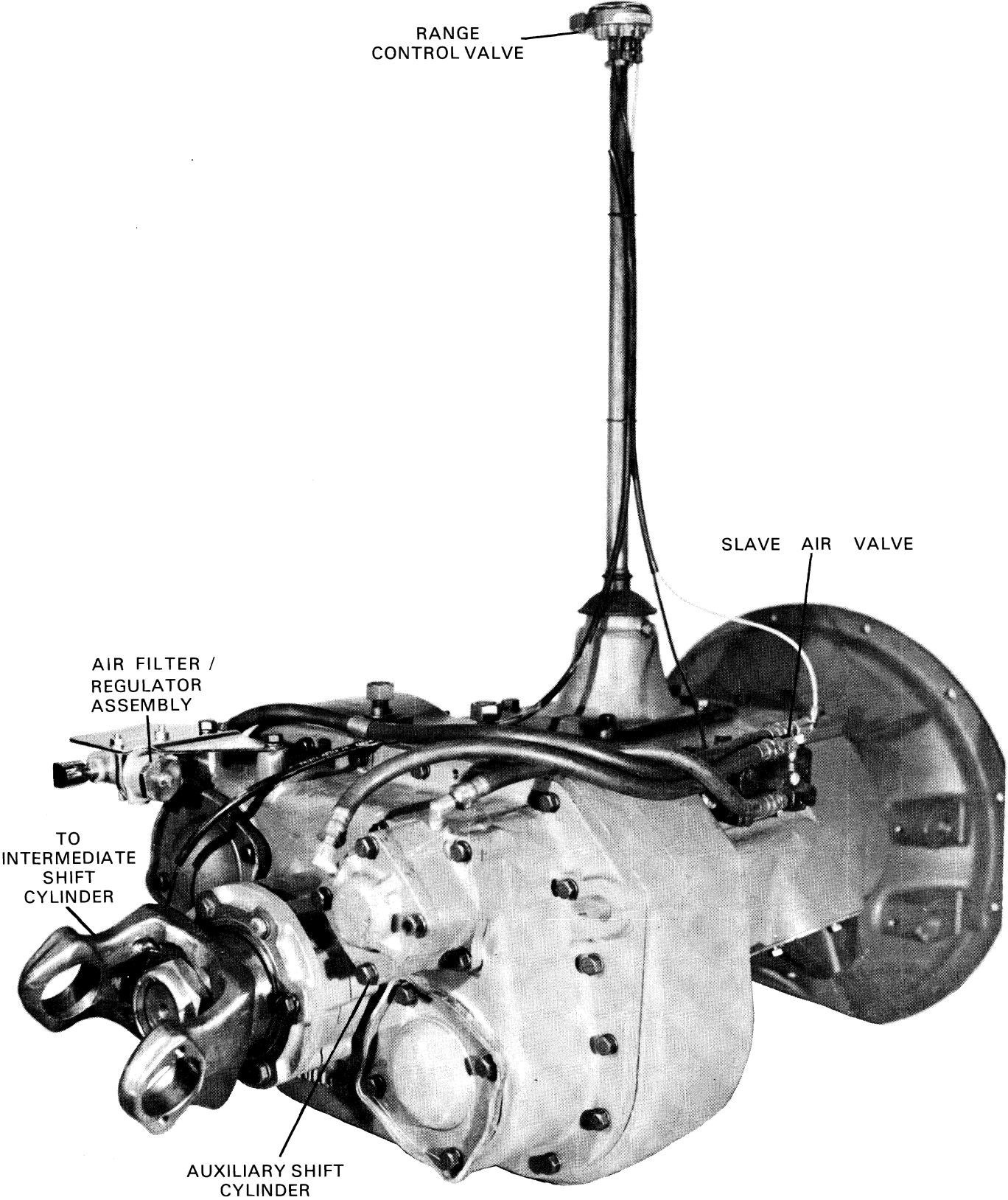

## Air Valve Operation

When in “low” and “intermediate” the control valve shuts off the air supply to the end cap. Thus, the constant air entering at the constant supply port forces the piston to the rear. The constant air also flows through a channel in the center of the piston and to an external port which is aligned with the low range port of the air valve.

When in “direct” the control valve opens and supplies air to the end cap. Since the piston area is larger on this end of the piston, it is forced in the opposite direction. The external air port in the piston is now aligned with the direct range port of the air valve.

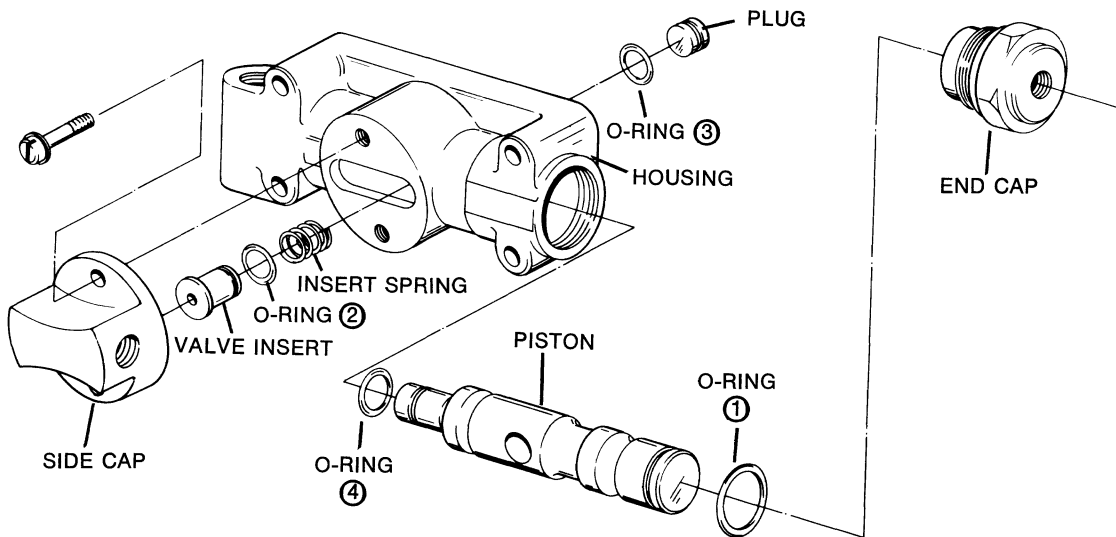

Exploded view of air valve. The alignment sleeve is not part of the assembly, but must be installed in housing for proper pre-select operation.

The four O-rings are indicated by circled numbers. If any of these are defective, there will be a constant air leak out of the exhaust on the air valve. In normal operation, exhaust will occur only for an instant as the range shift is made. The following chart is to be used as a guide to determine defective O-rings.

### Defective O-Rings

### RESULT

- |        |   |
|--------|---|
| ①      | Constant leak through exhaust in low range only.  |
| ② or ③ | Constant leak through exhaust in both ranges.   |
| ④      | Constant leak through exhaust in high range; steady but low volume leak through exhaust in low range. |

## To Disassemble Air Valve

1. Turn out the two capscrews and remove the side cap from valve body.
2. Remove the valve insert from piston and remove O-ring from the valve insert.
3. Remove the spring from piston.
4. Turn end cap from valve body, and withdraw piston from bore.
5. Remove the two-rings from piston.
6. Remove the nylon plug from piston and remove O-ring from plug.



**AIR REGULATOR**

The air regulator is not serviceable. If defective replace the air regulator unit. Reading at output of air regulator should be 57 to 62 psi.

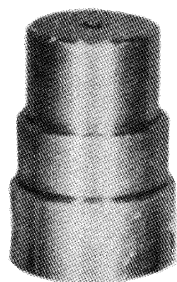

**AIR FILTER**

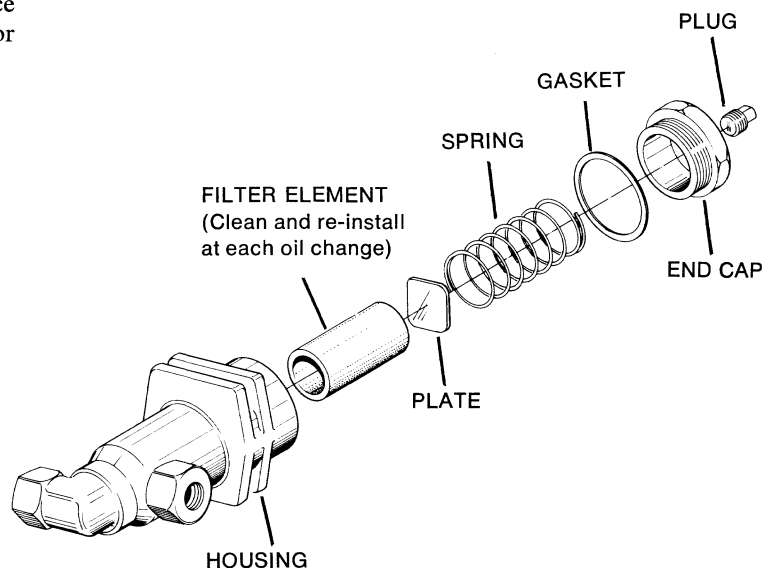

**AIR VALVE PRE-SELECTION**

An actuating pin protruding from the shifting bar housing prevents the actuating piston in the air valve from moving while the gear shift lever is in a gear position and releases the piston when the lever is moved to or through neutral. See detailed installation of air valve for installation precaution concerning the actuating pin.

**AIR FILTER & REGULATOR ASSEMBLY**

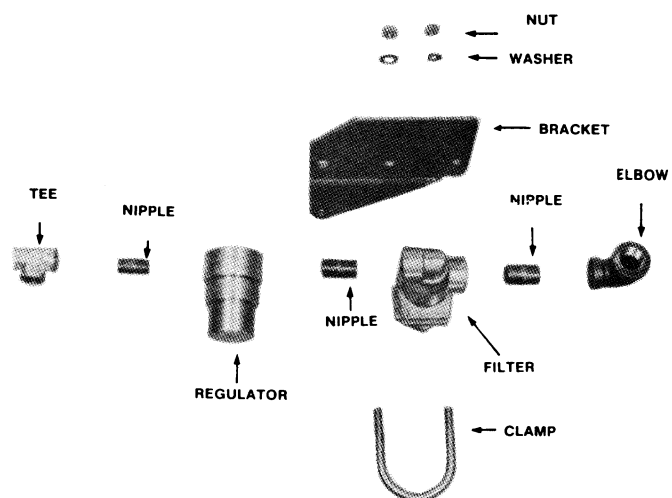

## RANGE CONTROL VALVE

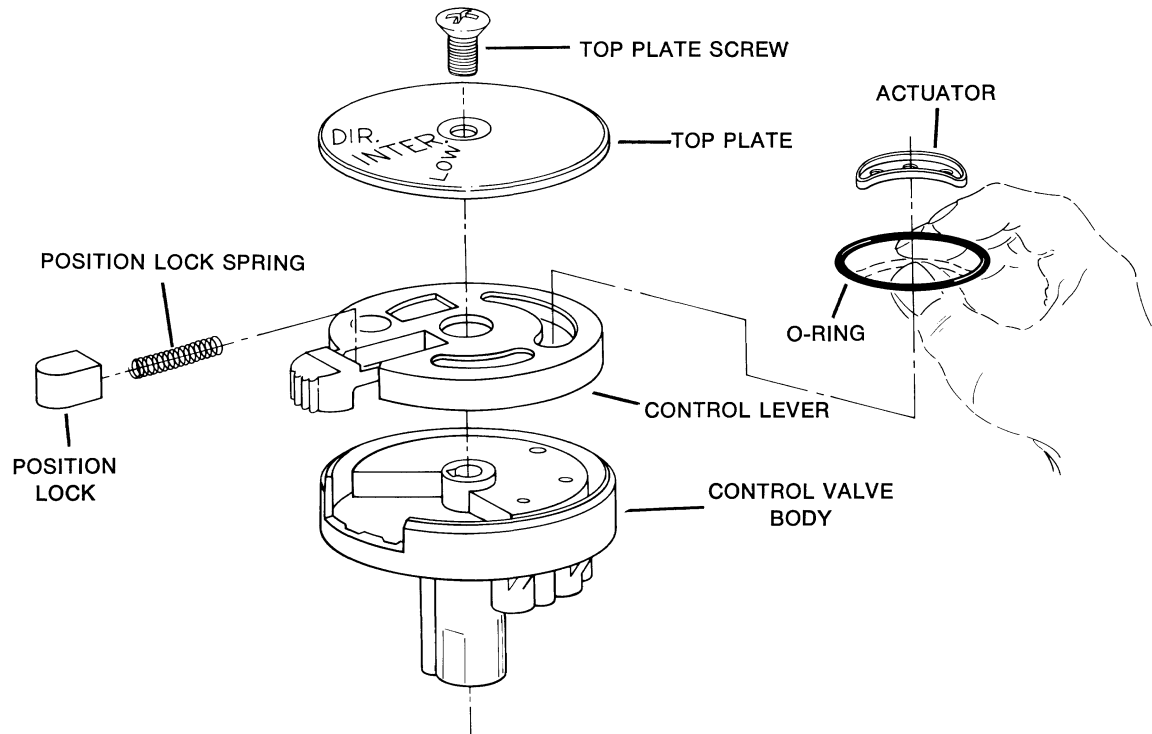

### DESCRIPTION

1. Porting — There are four ports in the bottom of the control:
  - a. The port stamped “S” is the supply port and is the constant air line from the air valve.
  - b. The port stamped “E” is the exhaust port and is left open.
  - c. The port stamped “R” is the signal line to the slave air valve.
  - d. The port stamped “F” is the signal line to the intermediate shift cylinder.
2. Maintenance and Assembly — The range control valve is easily disassembled by removing the top plate screw. Individual parts can be obtained in an A number kit. Critical assembly factors are:
  - a. Make sure that the jam nut locking the control valve to the shifting lever is secure.
  - b. Make sure that, when reassembled, the top plate screw is torqued with 90 to 120 inch-pounds. A loose top plate screw can affect valve operation.
  - c. When reassembling, lubricate the O-ring and O-ring carrier with a barium base grease.

### TROUBLE SHOOTING

1. With the range control in “LOW” position, disconnect the two lines connected to port “R” and “F”. There should be no air coming out of these ports.  
 Move the range control to “INTER.”. There should now be a steady flow of air coming from the “F” port, but still no air coming from the “R” port.  
 Move the range control valve to the “DIR.” position. There should now be a steady flow of air coming from both the “F” and “R” ports.

If the above results are not obtained, disconnect the supply air line at the “S” port and make sure that a steady flow of air is coming through the line. If air is present, this would indicate a faulty control valve. Cause can be defective parts, damaged O-ring or loose top plate screw.

2. Any steady flow of air from the range control valve exhaust port indicates a faulty range control valve or incorrect hook-up. Cause can be damaged O-ring, defective parts, loose top plate screw or reversed air lines on the control.

## INSERT VALVE – ALL MODELS

The insert valve located in the shift cylinder cover is a small 1-3/16" Humphrey valve. It is installed with the flat surface to the inside towards the center port, and it is secured with a special nut in bottom bore of cover.

When installing insert valve apply Dow Corning #200 lubricant or its equivalent to cylinder walls. When installing special nut apply Loctite hydraulic sealant to threads.

The insert valve is self-contained and can not be disassembled except for the three O-rings on outer diameter. These three O-rings are a stationary seal and do not move in cylinder.

Travel of the small piston in insert valve is only 3/16". The insert valve is a normally-open valve. Thus, when there is no signal or delivery of air to top side of insert piston, the constant air from regulator passes through the insert valve and to the backside of the piston and moves the shift bar forward (low range).

When the insert valve piston is activated by a signal or delivery of air, the insert valve is closed and shuts off the constant air to backside of shift piston. Air in shift cylinder is exhausted out through insert valve and bottom bore of cover.

When air is removed from backside of shift piston, constant air on frontside of shift piston moves the shift bar to the rear (intermediate and direct range).

**LOW RANGE**

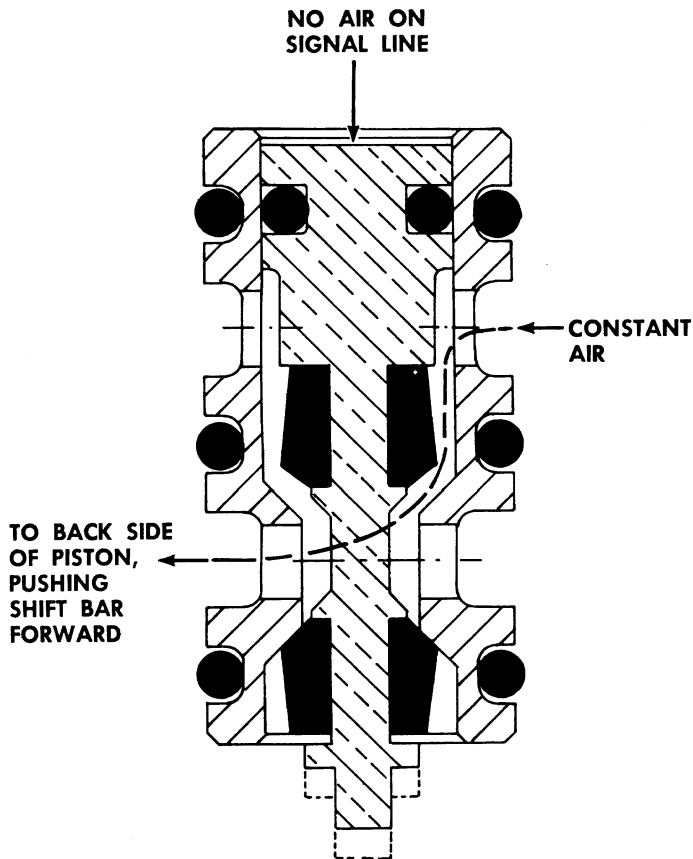

**INTERMEDIATE AND DIRECT RANGE**

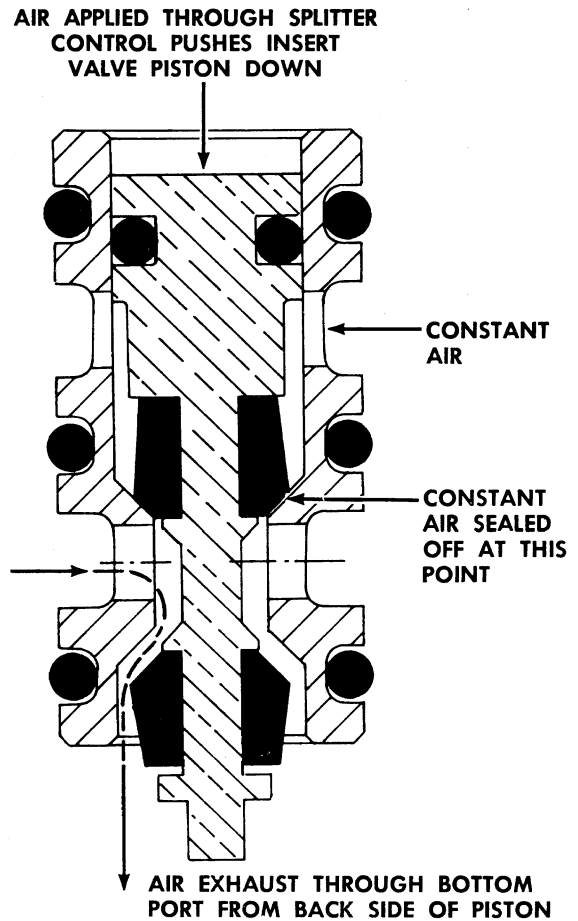

## INTERMEDIATE SHIFT CYLINDER AND COVER ASSEMBLY

*Operation* — Constant, regulated air is channeled through the cover to the front side of shift piston — air is always on this side of piston.

The shift piston is moved by removing or applying air (from constant supply) to the backside of piston. This piston area is larger and can overcome area of front side of piston. The removal or application of air on backside of piston is controlled by the insert valve in cylinder cover; this valve in turn is controlled by the range control valve.

### Trouble Shooting Cylinder

There are two O-ring seals in the shift cylinder.

1. *Leak at seal A* — Possible failure to shift or slow shift to intermediate or direct plus pressurizing of transmission.
2. *Leak at seal B* — Slow range shift between low and intermediate plus leak out cover exhaust when in intermediate or direct.

### Trouble Shooting Cover Assembly

1. *Exhaust port* — Any constant flow of air out the cover exhaust port usually indicates a faulty insert valve. Exhaust should occur briefly **ONLY** when the splitter control is moved from “low” to “intermediate.”
2. *Insert valve* — A faulty insert valve, leaking at the outer diameter O-rings or inner seals will result in failure to shift. Two indications of O-ring or seal failures are:
  - a. Constant leak out cover exhaust.
  - b. Constant leak out splitter control exhaust with splitter control in “low,” (providing range control valve is operating properly.)

The three O-rings on outer diameter of the insert valve can be replaced. If an inner seal is damaged, the entire insert valve will have to be replaced.

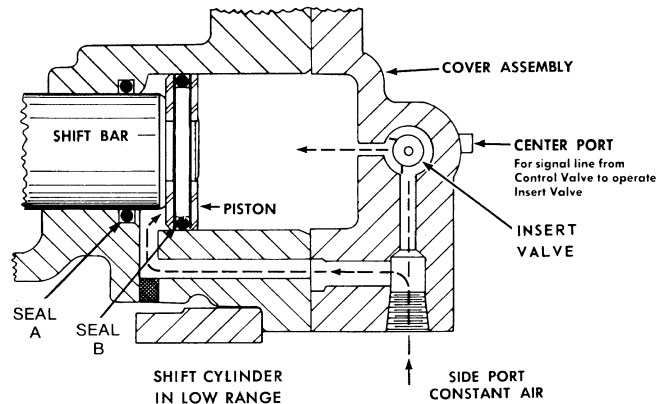
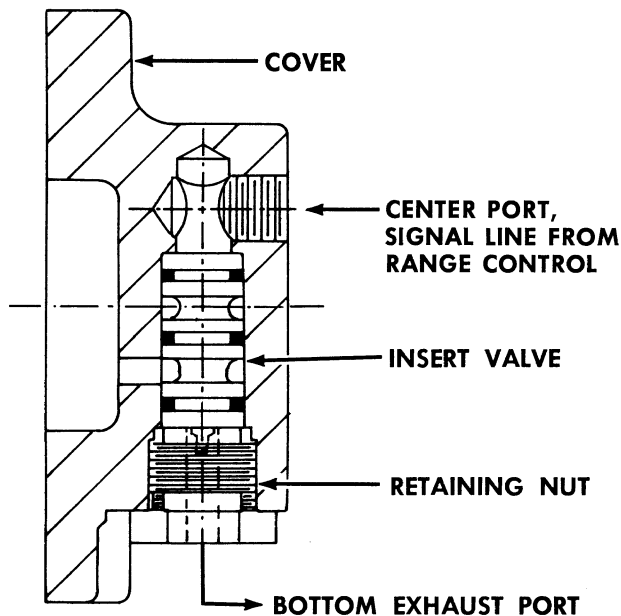



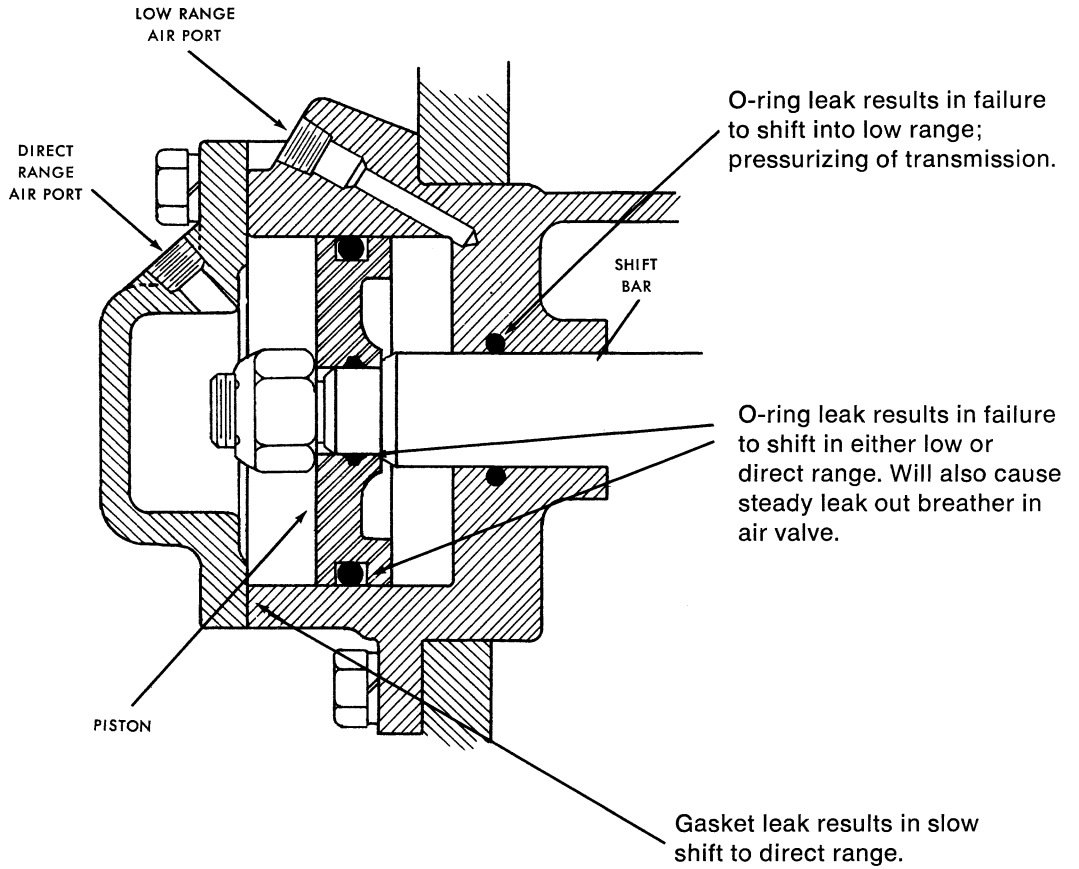

**CROSS SECTION OF AUXILIARY SHIFT CYLINDER**

**AIR FLOW DIAGRAMS**

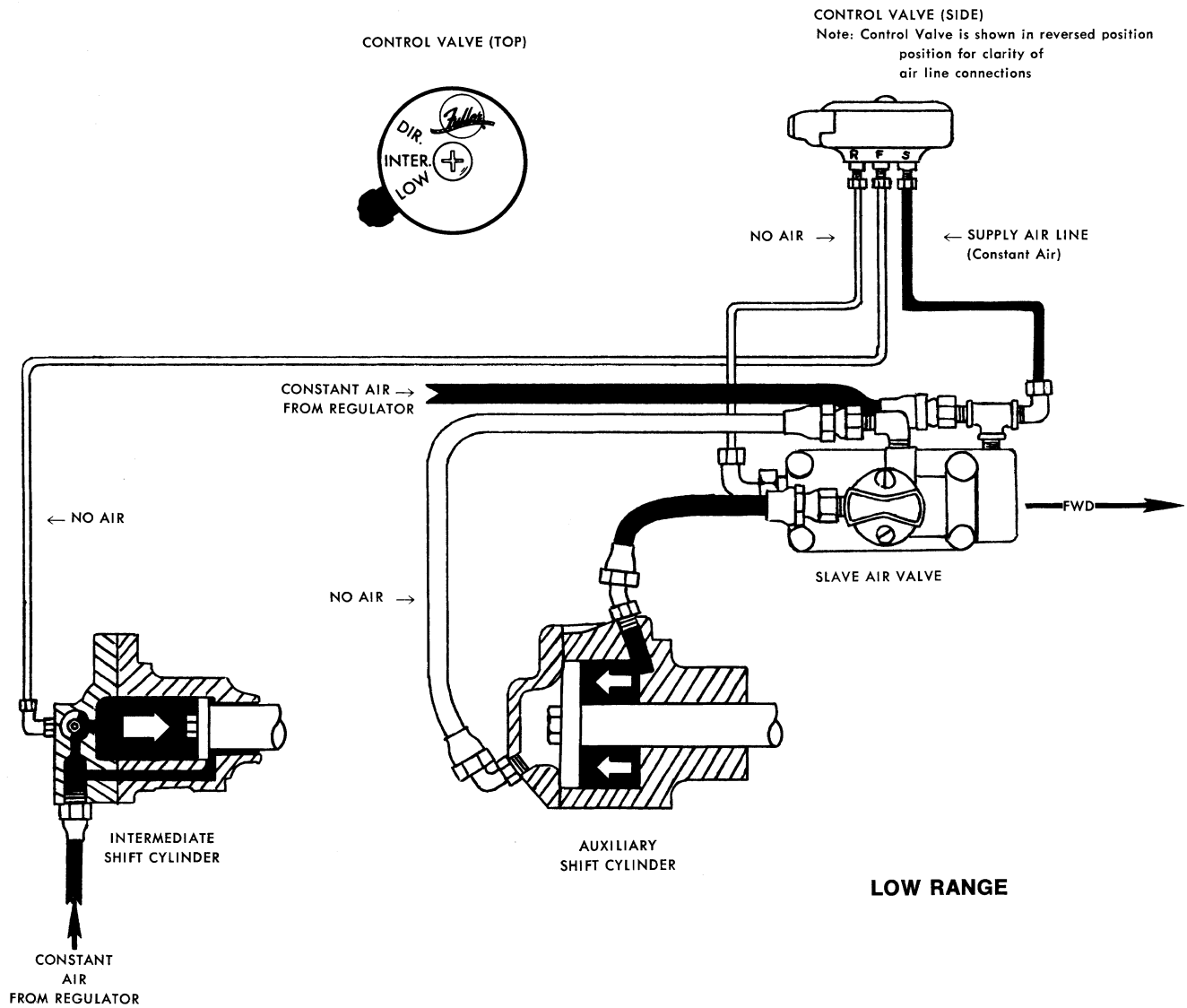

# AIR SYSTEM – AIR FLOW DIAGRAMS

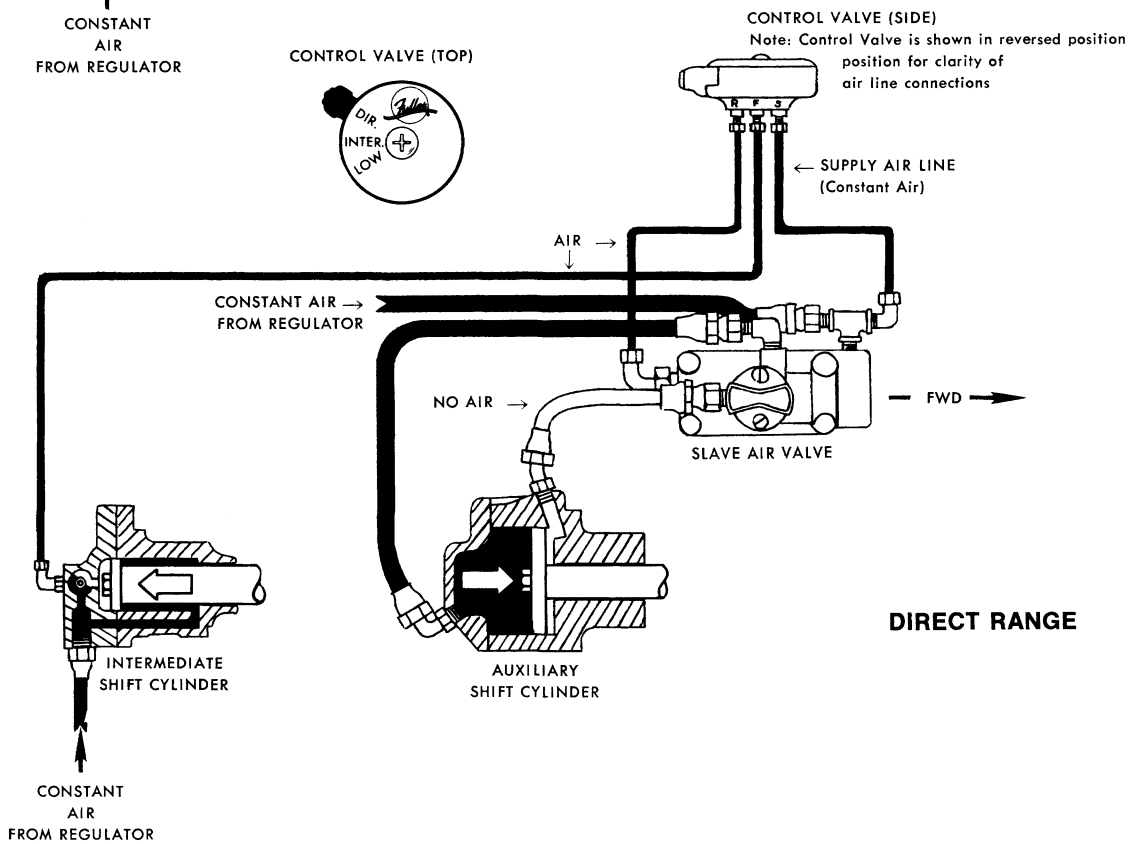
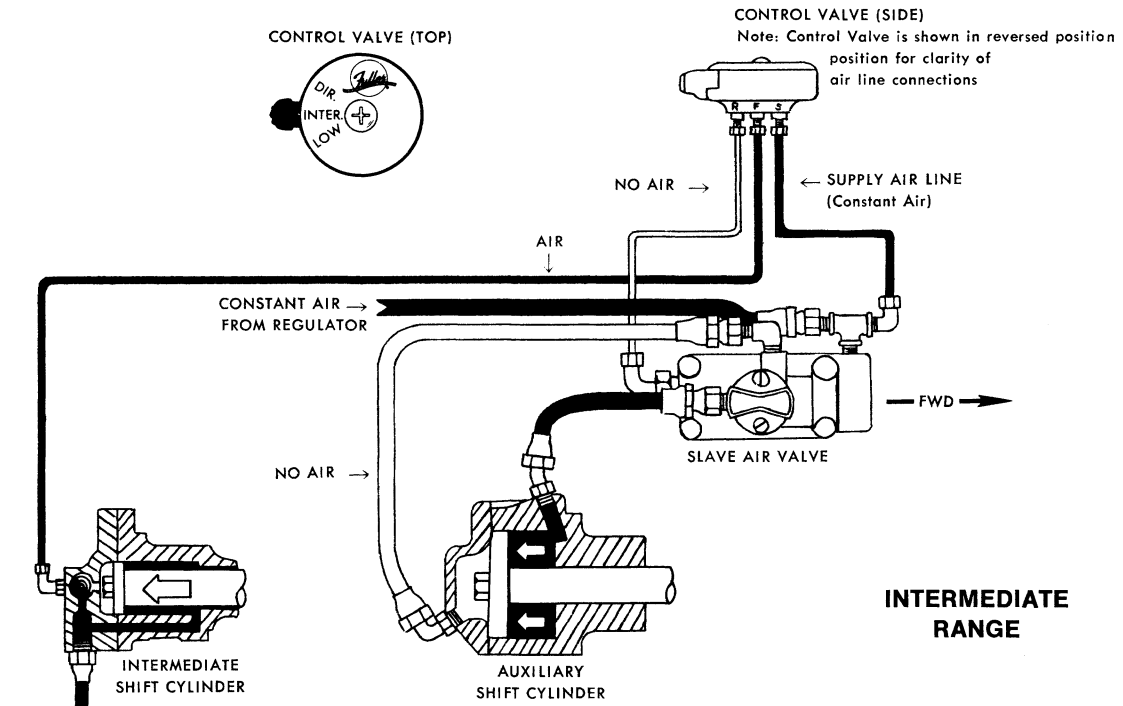

## TOOL REFERENCE

Some illustrations in this manual show the use of specialized tools. These tools are recommended for transmission repair as they make repair easier, faster and prevent costly damage to critical parts.

Some of these tools can be obtained from a regular tool

supplier, while others can be made either from prints or dimensions as required by the individual user.

Listed below are illustrations which show these specialized tools, the tool name and how it can be obtained. Prints are available for tools which have a Fuller tool number; send requests to the Service Department.

Page No.	Illustration	Tool	Fuller Tool No. or Source
24	13	Bearing Puller	T-10325
25	14	Lift Bracket	T-22823
34-37	8-8	Small Jaw Puller	Tool Supplier
53-61	10-3	Bearing Driver	T-7551
58-68	3-10	Bearing Driver	T-10324
59	7	Sleeve Driver	T-16552-1-AP-2, or make from 3/16" thick, 8" long steel tubing with an inner diameter of 2".
60	5	Drive Gear Bearing Driver	T-18042-69
68	13	Oil Seal Driver	T-18088-23
72	3	Bearing Driver	TL-18042-50
75	2	Torque Wrench, 185 ft.-lb. cap.	Tool Supplier
75	1	Torque Wrench, 500 ft.-lb. cap.	Tool Supplier





Copyright Eaton Corporation, 2012. Eaton hereby grant their customers, vendors, or distributors permission to freely copy, reproduce and/or distribute this document in printed format. It may be copied only in its entirety without any changes or modifications. THIS INFORMATION IS NOT INTENDED FOR SALE OR RESALE, AND THIS NOTICE MUST REMAIN ON ALL COPIES.

**Note:** Features and specifications listed in this document are subject to change without notice and represent the maximum capabilities of the software and products with all options installed. Although every attempt has been made to ensure the accuracy of information contained within, Eaton makes no representation about the completeness, correctness or accuracy and assumes no responsibility for any errors or omissions. Features and functionality may vary depending on selected options.

**For spec'ing or service assistance, call 1-800-826-HELP (4357) or visit [www.eaton.com/roadranger](http://www.eaton.com/roadranger). In Mexico, call 001-800-826-4357.**

Roadranger: Eaton and trusted partners providing the best products and services in the industry, ensuring more time on the road.

**Eaton Corporation**

Vehicle Group  
P.O. Box 4013  
Kalamazoo, MI 49003 USA  
800-826-HELP (4357)  
[www.eaton.com/roadranger](http://www.eaton.com/roadranger)

Printed in USA

For parts or service call us  
Pro Gear & Transmission, Inc.



**1 (877) 776-4600**

**(407) 872-1901**

**parts@eprogear.com**

**906 W. Gore St.**

**Orlando, FL 32805**

