

# Fuller Transmissions TRTS0920

July 2011



*Powering Business Worldwide*

BACKED BY

**Roadranger**

SUPPORT

# Warnings and Precautions

---

## Warnings and Precautions



**Before starting a vehicle always be seated in the driver's seat, place the transmission in neutral, set the parking brakes and disengage the clutch.**

**Before working on a vehicle place the transmission in neutral, set the parking brakes and block the wheels.**

**Before towing the vehicle place the transmission in neutral, and lift the rear wheels off the ground, remove the axle shafts, or disconnect the driveline to avoid damage to the transmission during towing.**

The description and specifications contained in this service publication are current at the time of printing.

Eaton Corporation reserves the right to discontinue or modify its models and/or procedures and to change specifications at any time without notice.

Any reference to brand name in this publication is made as an example of the types of tools and materials recommended for use and should not be considered an endorsement. Equivalents may be used.



This symbol is used throughout this manual to call attention to procedures where carelessness or failure to follow specific instructions may result in personal injury and/or component damage.

Departure from the instructions, choice of tools, materials and recommended parts mentioned in this publication may jeopardize the personal safety of the service technician or vehicle operator.

**Warning:** Failure to follow indicated procedures creates a high risk of personal injury to the service technician.

**Caution:** Failure to follow indicated procedures may cause component damage or malfunction.

**Note:** Additional service information not covered in the service procedures.

**Tip:** Helpful removal and installation procedures to aid in the service of this unit.

**Always use genuine Eaton replacement parts.**

## General Information

How to use this Troubleshooting/Operation Guide .....	1
Transmission Identification .....	2
Component Identification .....	4
Lubricants and Sealants .....	6
Suggested Test Fixtures .....	7

## Air System Troubleshooting

8, 9, 10, 11, 13, 15, and 18-Speed Troubleshooting ...	8
RTLO 10-Speed Troubleshooting .....	23
Combination Cylinder Troubleshooting .....	33
FR-1X210 Troubleshooting .....	51

## Operation

Air Line Color Chart .....	64
Slave Valve Preselection System .....	65
7,8,9 and 10-Speed Range Air Systems .....	66
7L,8,9 and 10-Speed (2-Speed auxiliary) .....	67
RT & RTO-610,6610, 6609, and 8609 Models .....	69
Deep Reduction Air System (with Dash Mounted Valve) .....	71
RT, RTO, & RTX xx607LL, xx608LL, and xx615 models .....	72
Deep Reduction Air System (with A-6915 Roadranger Valve) .....	75
RT, RTO, & RTX xx607LL, xx608LL, and xx615 Models .....	76
9 and 13-Speed Air Systems (Top 2 & Convertible) and 18-Speed (Top-2) ....	79
RT, RTO, & RTOO xx613 and xx813 Models .....	83
RTLO-xx613 Models .....	86
RTLO-xx713 Models .....	89
RTLO-xx913 Models .....	92
RTO-15618 and RTLO-xx618 Models .....	95
RTLO-xx718 Models .....	99
RTLO-xx918 Models .....	103
Combination Cylinder Air System .....	107
7LL/DLL/MLL, 8LL, 9MLL, and 15-Speed Models ..	108
Unique Air Systems .....	111
RT & RTO 613 and 6613 Models .....	112
RT & RTO 613 and 6613 Models With A-6913 Roadranger Valve .....	115
RT & RTO 613 and 6613 Models .....	116
7608LL with A-6915 Roadranger Valve .....	119
7608LL Models .....	120
RTLO-xx610 Speed Air System .....	123

RTLO-xxX610 Models .....	125
RTL-xx710 Speed Models .....	129
RTL-xx710 Models .....	130
AT-1202 Auxillary Transmission (with 2 Position Shift Valve) .....	134
AT-1202 Auxiliary Housing (3 Position Valve) .....	135

## System Components

A-4740 Air Filter/Regulator Assembly .....	137
A-5161/A-5454 Air Filter/Regulator Assembly .....	138
A-3546 Range Valve .....	139
A-5010/A-6909 Roadranger Valve .....	140
14651 Reduction Valve (Dash-Mounted) .....	141
A-5015/A-6915 Roadranger Valve .....	142
Two Position Selector Valve .....	143
A-4900/A-6913 Roadranger Valve .....	144
A-5013/A-6913 Roadranger Valve .....	145
Three Position Selector Valve .....	147
A-5510/A-6910 Roadranger Valve .....	148
Range Actuator Valve (Old Design) .....	150
Range Actuator Valve (Latest Design) .....	151
19470 Poppet-Type Slave Valve .....	152
A-4688 Slave Valve .....	153
A-5000 Slave Valve .....	154
Range Cylinder .....	155
Range Cylinder for 610, 6610, 6609 and 8609 .....	156
Dash-Mounted Deep Reduction Cylinder .....	157
Deep Reduction Cylinder with Roadranger Valve ....	158
RTLO-xx610 Model Range Cylinder Assembly .....	160
RTL-xx710 Model Range Cylinder Assembly .....	162
Intermediate Shift Cylinder Assembly 613 and 6613, 3-Position Selector Valve .....	164
Intermediate Shift Cylinder Assembly 613 and 6613, A-5015 Roadranger Valve .....	166
Combination Cylinder Assembly .....	168
Splitter Cylinder Assembly .....	171
RTLO-xx610 Model Splitter Cylinder Assembly (Old Design) .....	173
RTLO-xx610 Model Splitter Cylinder Assembly (Latest Design) .....	175
RTL-xx710 Model Splitter Cylinder Assembly .....	177
RTLO-xx613 Model Splitter Cylinder Assembly .....	179
RTLO-xx713 Model Splitter Cylinder Assembly .....	181
RTLO-xx913 Model Splitter Cylinder Assembly .....	183
RTO-15618 and RTLO-xx618 Model Splitter Cylinder Assembly .....	185
RTLO-xx718 Model Splitter Cylinder Assembly .....	187
RTLO-xx918 Model Splitter Cylinder Assembly .....	189

# Table of Contents

---

## Engineering Reference Drawings

Basic Air System Drawings - 6610, 8609, and 6609 .....	191
Basic Air System Drawings - 07L, 08, 08L, 09, and 10-Speed Models .....	192
Basic Air System Drawings - 07LL, 08LL, and 15 Speed Models .....	193
Basic Air System Drawings - 707LL, 7/908LL, 7/909LL, and 7/915 Speed Models .....	194
Basic Air System Drawings - 11613, 14613, and 15613 Speed Models .....	195
Basic Air System Drawings - 6613, and 7608LL Speed Models .....	196
Basic Air System Drawings - 18 Speed Models Left-Hand Drive .....	197
Basic Air System Drawings - 18 Speed Right-Hand Drive .....	198

## **How to use this Troubleshooting/Operation Guide**

The purpose of this manual is to assist in the diagnosis and repair of your air system. Use this manual in conjunction with other service literature produced by Eaton®, including Service Bulletins, Illustrated Parts Lists, Service Manuals, and OEM service material.

## **This guide provides four functions**

- Troubleshooting Guide: Designed to isolate and resolve air system problems.
- System Operation and Schematics: Designed to explain a complete air system's operation.
- System Components: Designed to explain each component's function and operation.
- Engineering Reference Drawings: Detailed drawings with optional parts and part numbers.

For parts or service call us  
Pro Gear & Transmission, Inc.



**1 (877) 776-4600**

**(407) 872-1901**

**parts@eprogear.com**

**906 W. Gore St.**

**Orlando, FL 32805**



# General Information

---

## Transmission Identification

### 2-Speed Auxiliary/3-Speed and 2x2 Auxiliary

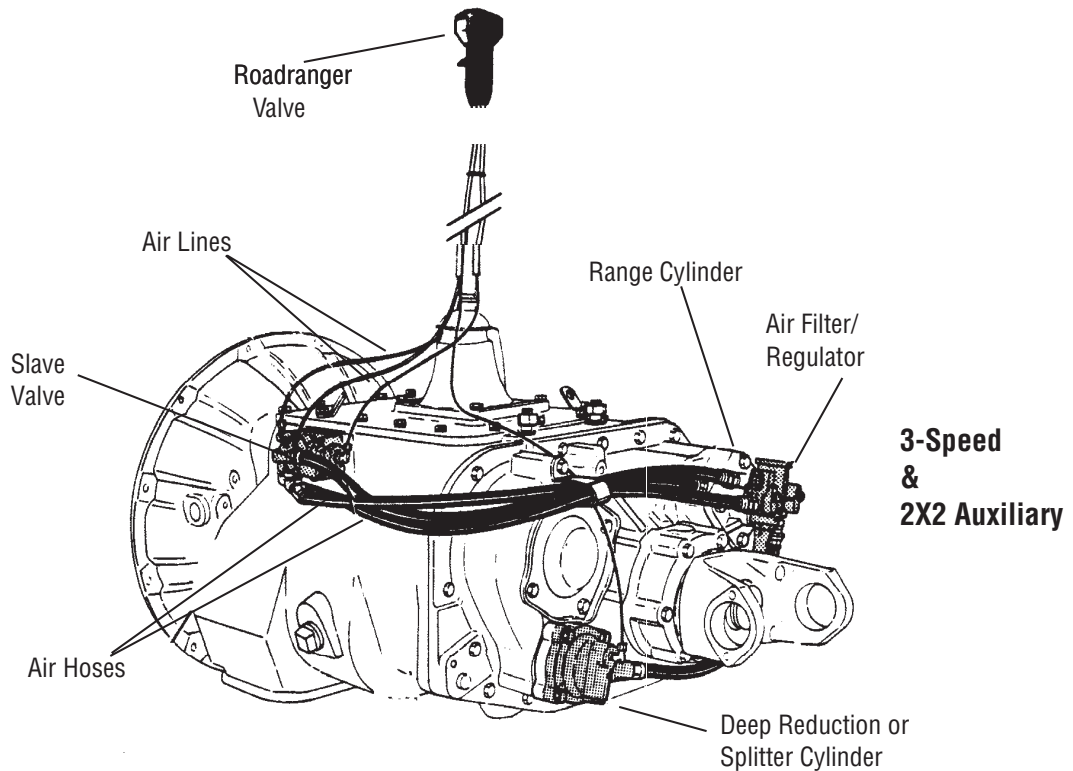
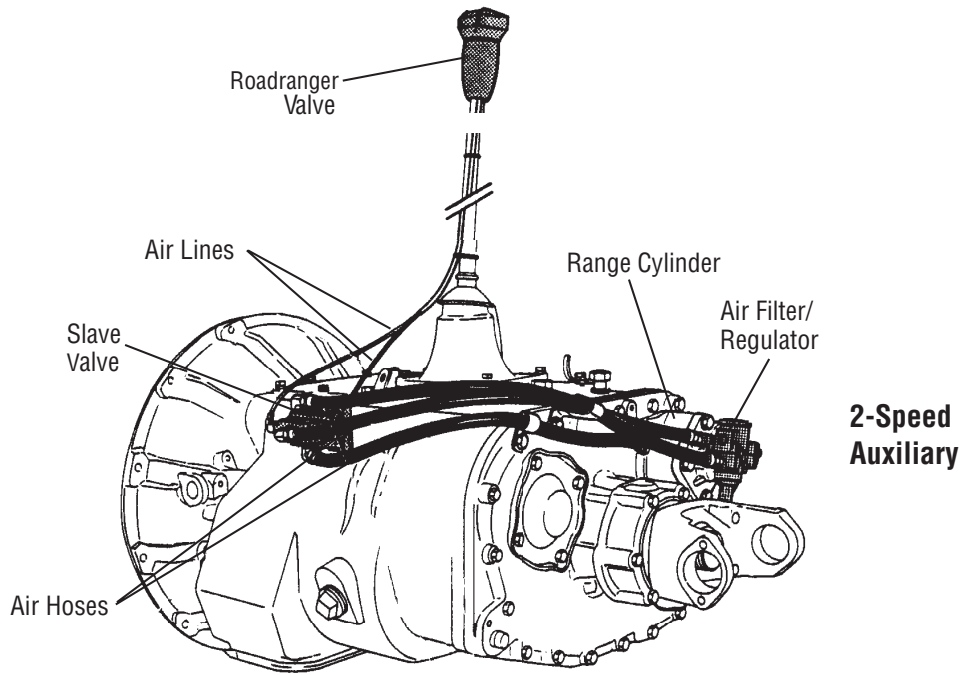

**Combination Cylinder / RTLO-10 Speeds**

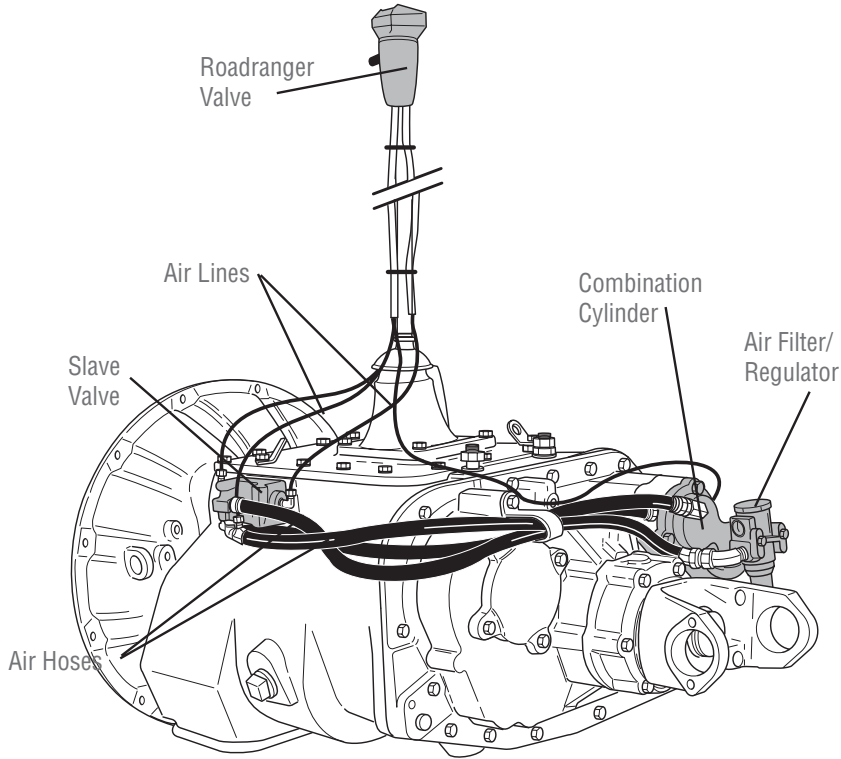

**Combination  
Cylinder**

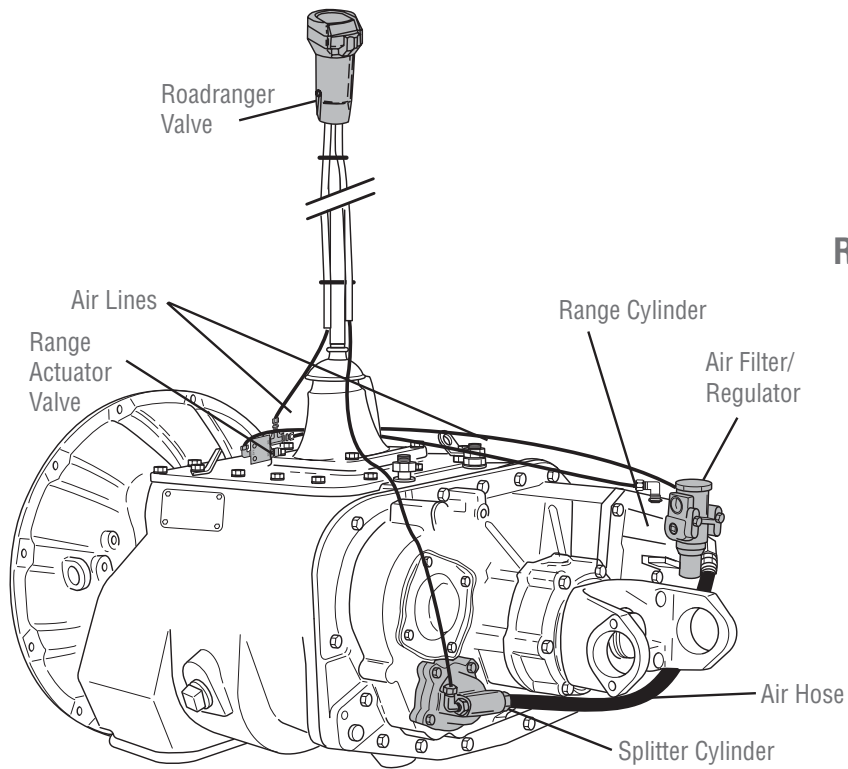

**RTLO-10 Speeds**

General Information



# General Information

---

## Component Identification

### Air Filter/ Regulators

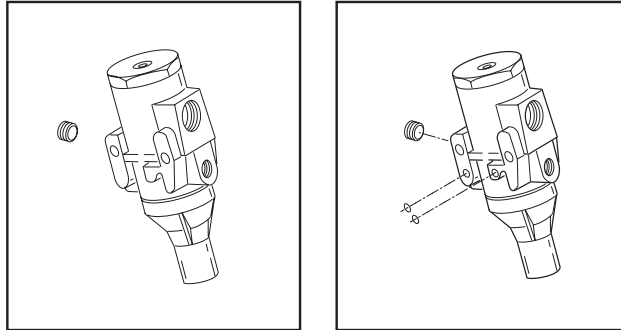

### Control Valves - Old Production

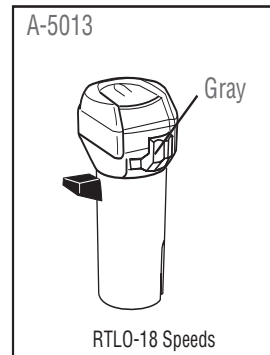
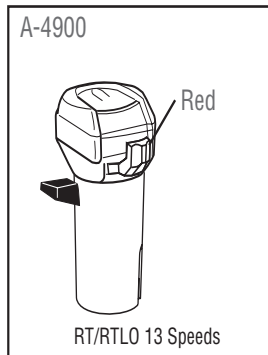
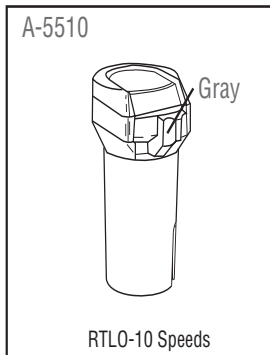
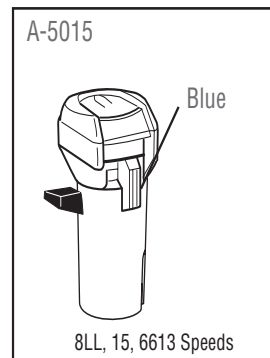
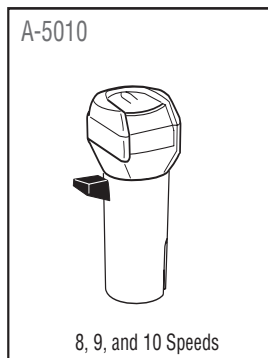
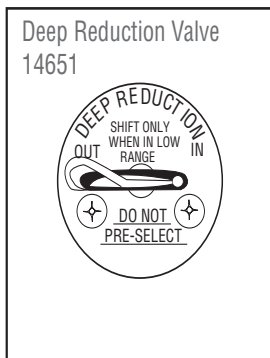
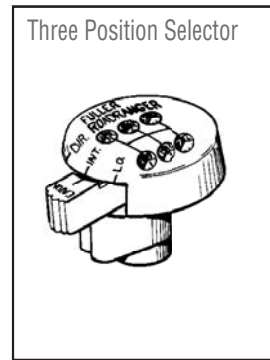
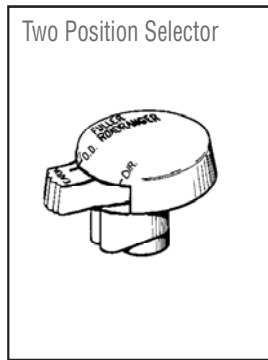
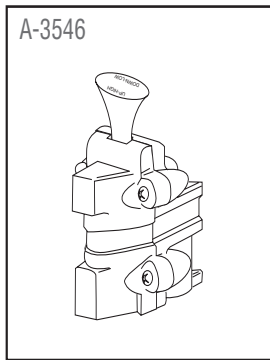

**Control Valves - Current Production**

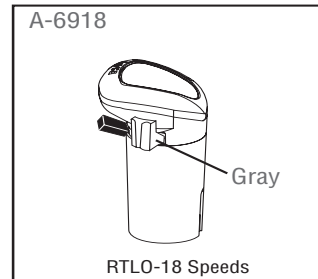
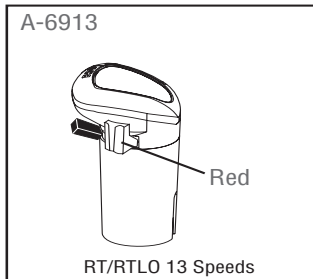
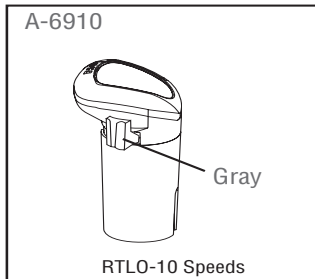
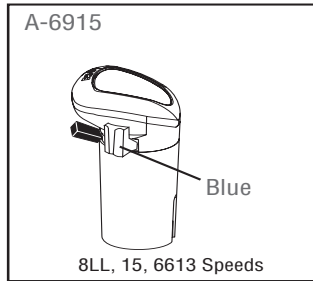
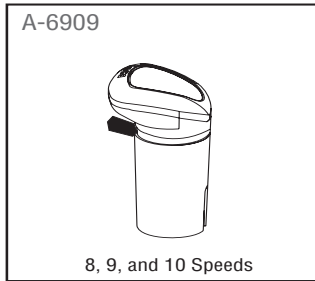

**Slave Valves**

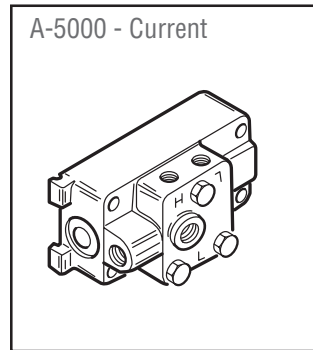
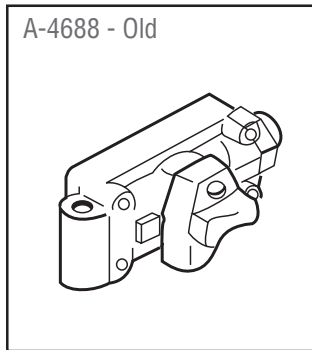
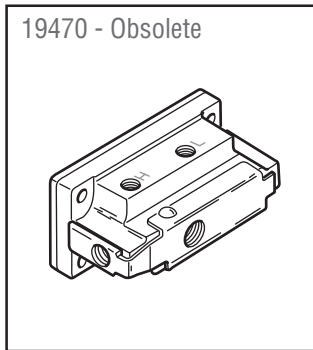

**Range Valves**

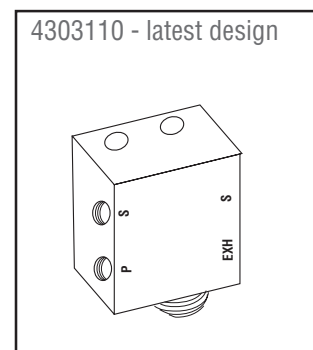
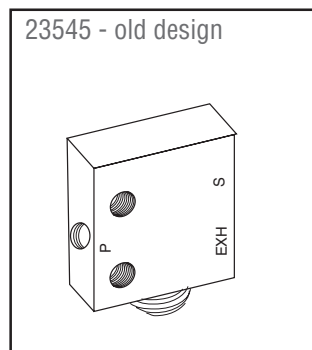
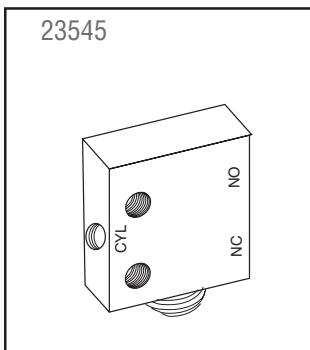

General Information

# General Information

---

## Lubricants and Sealants

The use of improper sealants and lubricants during air system assembly can cause improper component operation and severe transmission damage.

The following are the recommended sealants and lubricants to be used when assembling air system components:

Name:	Eaton® Fuller® Silicone Lubricant
Part #:	71203 (8 oz. container)—Fleet size
Part #:	71206 (4 cc container)—Single application
Where Used:	All O-rings and mating surfaces

Name:	Eaton® Fuller® Sealant
Part #:	71205 (2 cc container)—Single application
Part #:	71206 (4 cc container)—Single application
Where Used:	Air fittings and threads

## Suggested Test Fixtures

**Note:** For the Automated transmission models, refer to their Troubleshooting Guides for air system diagnostics.

### Test Fixture for Range Cylinder

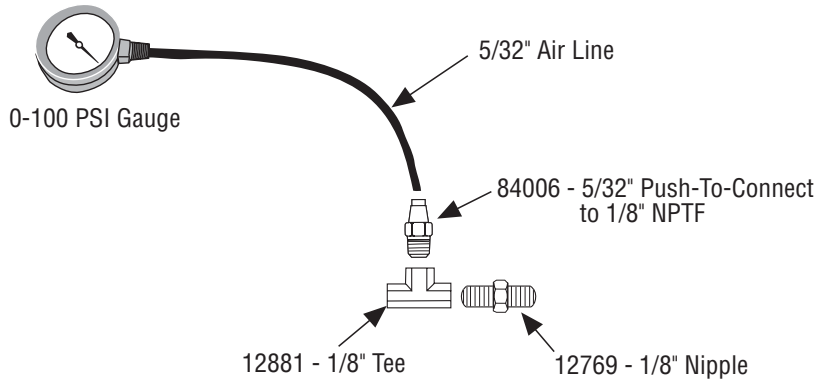

### Test fixture for 1/8" Air lines

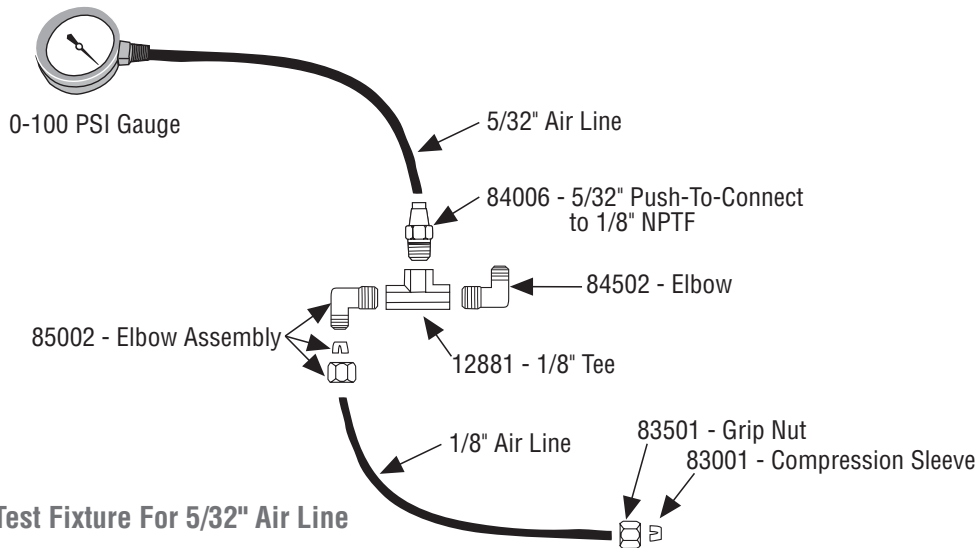

### Test Fixture For 5/32" Air Line

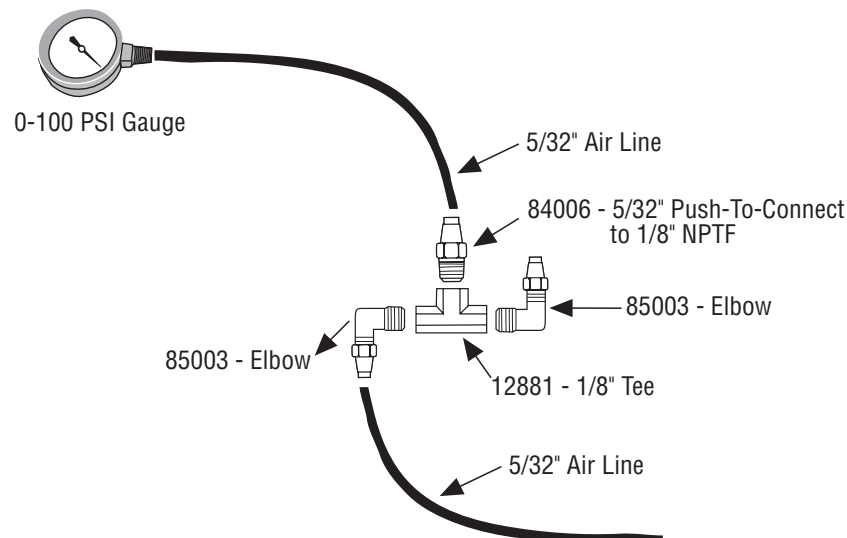

# Air System Troubleshooting

---

## 8, 9, 10, 11, 13, 15, and 18-Speed Troubleshooting

### Symptom

- Air Leak at Shift Knob
- Air Leak at Slave Valve
- Air Leak from Transmission Breather or Transmission Case is Pressurized
- Air Leak at Splitter Cylinder Cover Exhaust Port
- No or Slow Range Shift into Low
- No or Slow Range Shift into High
- Range Shifts with Shift Lever in Gear



**WARNING:** Use care when removing air lines or checking for air flow from disconnected lines. High pressure air may exhaust suddenly. Wear safety glasses. Exhaust all air pressure from system before removing air filter/regulator or combination cylinder cover.

**Note:** During all testing, the vehicle air pressure must be greater than 90 PSI (620 kPa). If during testing the pressure falls below 90 PSI (620 kPa), make sure the transmission is in neutral, start the engine, and let the pressure build to governor cutoff. After the pressure reaches the governor cutoff, continue testing. The pressure is critical if the vehicle is equipped with a Pressure Protection Valve that would shut off the air supply to certain air circuits if the system pressure dropped below a preset level.

**IMPORTANT:** Use the following air system troubleshooting procedures for part replacement **only if the symptom can be duplicated**. If the problem is intermittent, parts that are not defective could be replaced.

### Instructions

1. Start at “Procedures” for Step A.
2. Based on the “Result” of the procedure, go to the corresponding “What To Do Next”.

## Procedure 1: Symptom - Air Leak at Shift Knob

### Normal Operation:

- A burst of air will be exhausted from the shift knob when moving the range selector from low to high. This is the air being exhausted from the “P” air line.
- A burst of air will be exhausted from the shift knob when moving the splitter button rearward (shifting to low split). This is the air being exhausted from the “SP” air line.

### Possible Causes:

- Incorrectly attached air lines
- Internal leak in slave valve
- Internal leak at insert valve
- Internal leak at shift knob

Table 10 Air Leak at Shift Knob

	Procedure	Result	What to do next
Step A	Remove lower skirt on shift knob. Check for leaking fitting at the shift knob.	Leak found.	Repair leaking fitting or air line.
		No leak found.	Go to Step B.
Step B	Check air lines to make sure all lines are connected to the proper ports on the shift knob.  A.) Reversal of “S” and “P” lines will result in a constant leak from the exhaust when high range is selected. B.) Reversal of the H/L and “SP” lines will result in a constant leak when the splitter button is rearward.	Air lines are not connected to the proper ports.	Connect lines properly.
		Air lines are connected to the proper ports.	Go to Step C.
Step C	Move the range selector lever down to low range. Check for constant air flow from the exhaust “E” port.	Constant air flow from the “E” port.	Replace knob.
		No air flow from “E” port.	Go to Step D.
Step D	Move the range selector up to high range. Disconnect the small air line connected to the “P” port of the shift knob. Check for air flow from the port and air line.	Constant air is leaking from the “P” port or the “E” port.	Repair or replace the shift knob.
		Air is coming out of the disconnected air line.	1. Verify that the air line is connected to the slave valve “p” port.  2. If properly connected, replace the slave valve.
		Air is not leaking from either port or disconnected air line.	Go to Step E.



## Procedure 2: Symptom - Air Leak at Slave Valve

### Normal Operation:

A momentary exhaust of air at the slave valve occurs during a range shift. The air from the low side of the range cylinder is exhausted as air pressure is applied to the high range side. Likewise, air from the high range side of the piston is exhausted as air pressure is applied to the low range side. The exhaust port is located at the slave valve to transmission mounting interface.

### Possible Causes:

- Internal leak in range cylinder.
- Internal leak in slave valve.

Table 11 Air Leak at Slave Valve

	Procedure	Result	What to do next
Step A	Confirm that air is leaking from the exhaust port on the slave valve and not a fitting or air line.	Air is leaking from fitting or air line.  Air is definitely leaking from slave valve exhaust port.	Repair or replace fitting or air line.  Go to Step B.
Step B	Move range selector down to select low range. Remove the 1/4" I.D. rubber air line at the high range supply port on the range cylinder. Feel for air flow from the open port on the range cylinder. Notice if the air leak at the slave valve only occurs when the transmission is in high range. Repeat the above test but remove the low range air hose and check with high range selected.	Air is flowing from high range supply port on range cylinder.  No air flow from high range port.	Remove range cylinder cover and repair leaking range piston or piston seal. After repair, check for proper range operation.  Repair or replace slave valve.



# Air System Troubleshooting

---

## Procedure 3: Symptom - Air Leak from Transmission Breather or Transmission Case is Pressurized

### Normal Operation:

There should be no measurable air flow from the transmission breather.

### Possible Causes:

- Leak at range yoke bar O-ring
- Leak at splitter yoke bar O-ring

Table 12 Air Leak from Transmission Breather or Transmission Case is Pressurized

	Procedure	Result	What to do next
Step A	Listen for the air leak with the transmission shifted to both low and high range.	Leak is only in low range.	Remove range cylinder and inspect for damaged range yoke bar, yoke bar O-ring, or range cylinder. Repair as necessary.
		Leak is in both low and high range.	Remove splitter cylinder. Inspect for damaged splitter yoke bar, O-ring, or cylinder. Repair as necessary.

## Procedure 4: Symptom - Air Leak at Splitter Cylinder Cover Exhaust Port

**Normal Operation:**

A burst of air will exhaust from this port when shifting into low split (the splitter button is moved rearward while in low range).

**Possible Causes:**

- Damaged/defective insert valve
- Leak past insert valve external O-rings
- Leak past splitter cylinder piston

Table 13 Air Leak at Splitter Cylinder Cover Exhaust Port

	Procedure	Result	What to do next
Step A (old style)	Remove insert valve. Check for contamination, damaged seals, or sticky movement. Check the insert valve bore in the splitter cylinder cover for contamination or damage which would result in leakage past the insert valve O-rings.	Contamination or damage found.	Repair or replace as necessary.
		No contamination or damage found.	Go to Step B.
Step B	Remove the splitter cylinder cover and piston. Check the piston bore for contamination or damage. Check the piston seals for damage. NOTE: Early production transmissions used a paper gasket to seal the splitter cover to cylinder, if necessary, replace this configuration with the spool valve design which uses an O-ring.	Contamination or damage found.	Repair or replace as necessary.

# Air System Troubleshooting

## Procedure 5: Symptom - No or Slow Range Shift into Low

### Normal Operation:

When the range selector on the shift knob is moved down to select low range, air pressure will flow through the shift knob to the "P" port on the slave valve. The slave valve will direct air pressure through the low range 1/4" rubber hose to the range cylinder to shift the range. There will be a brief burst of air at the slave valve as the high range side of the range piston exhausts. Likewise, when high range is selected, the air pressure in the "P" will be exhausted at the shift knob. This will cause the slave valve to direct air to the rear side of the range cylinder piston. The air pressure on the low range side will be exhausted at the slave valve.

### Possible Causes:

- Incorrect air line hook up
- Insufficient air supply to transmission
- Damaged or defective air filter / regulator assembly
- Damaged or defective shift knob master valve
- Damaged or defective slave valve
- Damaged or defective range cylinder
- Damaged or defective range yoke or yoke bar
- Damaged or defective range synchronizer
- Damaged or defective gearing in auxiliary section of transmission

Table 14 No or Slow Range Shift into Low

	Procedure	Result	What to do next
Step A	Place the shift lever in neutral. Check for constant air leakage at the shift knob, slave valve, and transmission case breather when both low and high range have been selected.	Constant air leak is detected.	Go to the other corresponding symptom first. See beginning of Air System Troubleshooting section.
		No constant leak is detected.	Go to Step B.
Step B	Place shift lever in neutral. Move range selector up to high range position. At the rear of the transmission, disconnect the 1/4" rubber air line from the low range supply port on the range cylinder. Check for air flow from the low range port.	Air flows from the low range port.	Remove range cylinder cover and repair leaking range piston or piston seal.
		No air flow from low range port.	Go to step C.
Step C	Check for air flow from the disconnected air line.	Air flows from disconnected air line.	Go to step F.
		No air flow from disconnected line.	Go to step D.

Table 14 No or Slow Range Shift into Low

	Procedure	Result	What to do next
Step D	Install a 100 PSI air gauge in the disconnected air line end. With the shift lever in neutral, move the range selector down to select low range. Observe the gauge.	The gauge read 0 PSI.	Go to step F.
		The gauge reads pressure but is lower than 58 PSI or higher than 63 PSI.	Replace the filter/regulator and check for proper range operation.
		The gauge reads between 58 - 63 PSI.	Go to step E.
Step E	Confirm that shift lever is still in neutral. Have an assistant move the range selector up and down between low and high range. Does the pressure measured at the gauge respond rapidly when going from high to low?	Pressure rapidly changes between 58-63 PSI and 0 at the gauge.	Air system appears to be operating satisfactory. Go to step R.
		Pressure does not change rapidly at gauge.	<ol style="list-style-type: none"> <li>1. Check for a plugged or dirty filter in the filter/regulator assembly.</li> <li>2. Check for a pinched or obstructed 1/4" rubber air line between the filter/regulator and slave valve.</li> <li>3. Check for a pinched or obstructed 1/4" rubber air line between the slave valve and the test gauge.</li> <li>4. If all are satisfactory, go to step F.</li> </ol>
Step F	Place shift lever in neutral. At the shift knob, move the range selection lever up to select high range. At the slave valve, remove the air line from the "P" port. (should be a black line). Check for air flow from the disconnected line.	Air flows from the disconnected line.	<ol style="list-style-type: none"> <li>1. Confirm that the air lines are connected to the correct ports at the shift knob.</li> <li>2. If the lines are correct, replace the shift knob.</li> </ol>
		No air flow from the disconnected line.	Go to step G.
Step G	Check for air flow from the "P" port on the slave valve.	Air flows from this port.	Replace the slave valve.
		No air flow from this port.	Go to step H.

# Air System Troubleshooting

Table 14 No or Slow Range Shift into Low

	Procedure	Result	What to do next
Step H	Place the shift lever in neutral. Install a 100 PSI pressure gauge in line with the "P" line. Move the range selector back and forth from low to high range. The gauge should show rapid pressure change.	The gauge responds slowly.	<ol style="list-style-type: none"> <li>1. Check for a restricted line between the shift knob and slave valve.</li> <li>2. If the lines are correct, replace the shift knob.</li> <li>3. Check for a plugged or dirty filter in the filter / regulator assembly.</li> <li>4. Check for a pinched or obstructed 1/4" rubber air line between the filter/regulator and slave valve.</li> <li>5. Check for a pinched or obstructed air line between the slave valve and the "S" port on the shift knob.</li> <li>6. If all are good, replace the shift knob.</li> </ol>
		The gauge rapidly moves between 58-63 PSI and 0 PSI.	Go to step I.
Step I	<p>If possible, leave air lines attached to slave valve. Unbolt the slave valve from transmission side. Check for free movement of the plunger pin protruding from the case under the slave valve. The pin should extract when the transmission is shifted into gear and retract when shifted into neutral.</p> <p>NOTE: If desired, the slave valve can be actuated and tested while unbolted from the transmission case. The air lines, of course, must remain attached.</p>	Actuating plunger pin does not move freely.	<ol style="list-style-type: none"> <li>1. Remove actuating plunger pin and check for damage.</li> <li>2. Check for missing or broken spring.</li> </ol>
		Actuating plunger pin moves freely.	Repair or replace slave valve and check for proper range operation.

Table 14 No or Slow Range Shift into Low

	Procedure	Result	What to do next
Step R	<p>If air system has been tested and found to operate satisfactory, the auxiliary section must be removed to inspect for mechanical problem.</p> <p>Remove auxiliary section and inspect for:</p> <ul style="list-style-type: none"> <li>•Binding of range yoke bar or piston</li> <li>•Damaged or defective range yoke</li> <li>•Damaged or defective range synchronizer</li> <li>•Cracked countershaft weld resulting in gear turning on shaft</li> <li>•Damaged or defective range sliding clutch</li> <li>•Auxiliary section gearing out of time</li> </ul>		

# Air System Troubleshooting

## Procedure 6: Symptom - No or Slow Range Shift into High

### Normal Operation:

When the range selector on the shift knob is moved down to select low range, air pressure will flow through the shift knob to the 'P' port on the slave valve. The slave valve will direct air pressure through the low range 1/4" rubber supply hose to the range cylinder to shift the range. There will be a brief burst of air at the slave valve as the high range side of the range piston exhausts.

Likewise, when high range is selected, the air pressure in the "P" will be exhausted at the shift knob. This will cause the slave valve to direct air to the rear side of the range cylinder piston. The air pressure on the low range side will be exhausted at the slave valve.

### Possible Causes:

- Incorrect air line hook up
- Insufficient air supply to transmission
- Plugged filter
- Incorrect regulator pressure
- Damaged or defective shift knob master valve
- Damaged or defective slave valve
- Damaged or defective range cylinder
- Damaged or defective range yoke or yoke bar
- Damaged or defective range synchronizer
- Damaged or defective gearing in auxiliary section of transmission

Table 15 No or Slow Range Shift into High

	Procedure	Result	What to do next
Step A	Place the shift lever in neutral. Check for constant air leakage at the shift knob, slave valve, and transmission case breather when both low and high range have been selected.	Constant air leak is detected.	Go to the other corresponding symptom first. See beginning of Air System Troubleshooting section.
		No constant leak is detected.	Go to Step B.
Step B	Place shift lever in neutral. Move range selector down to low range position. At the transmission rear, disconnect the 1/4" rubber air line from the range cylinder high range supply port. Check for air flow from the cylinder high range port.	Air flows from the high range port.	Remove range cylinder cover and repair leaking range piston or piston seal. After repair, check for proper range operation.
		No air flow from high range port.	Go to step C.
Step C	Check for air flow from the disconnected air line.	Air flows from disconnected air line.	Go to step F.
		No air flow from disconnected line.	Go to step D.

Table 15 No or Slow Range Shift into High

	Procedure	Result	What to do next
Step D	Install a 100 PSI air gauge in the disconnected air line end. With the shift lever in neutral, move the range selector up to select high range. Observe the gauge.	The gauge reads 0 PSI.	Go to step F.
		The gauge reads pressure but is lower than 58 PSI or higher than 63 PSI.	Replace the filter/regulator and check for proper range operation.
		The gauge reads between 58 - 63 PSI.	Go to step E.
Step E	Confirm that shift lever is still in neutral. Have an assistant move the range selector up and down between low and high range. Does the pressure measured at the gauge respond rapidly when going from high to low.	Pressure rapidly changes between 58-63 PSI and 0 at the gauge.	Air system appears to be operating satisfactory. Go to step R.
		Pressure does not change rapidly at gauge.	<ol style="list-style-type: none"> <li>1. Check for a plugged or dirty filter in the filter/regulator assembly.</li> <li>2. Check for a pinched or obstructed 1/4" rubber air line between the filter/regulator and slave valve.</li> <li>3. Check for a pinched or obstructed 1/4" rubber air line between the slave valve and the test gauge.</li> <li>4. If all are satisfactory, go to step F.</li> </ol>
Step F	Place shift lever in neutral. At the shift knob, move the range selection lever up to select high range. At the slave valve, remove the air line from the "P" port. (should be black line). Check for air flow from the disconnected line.	Air flows from the disconnected line.	<ol style="list-style-type: none"> <li>1. Confirm that the air lines are connected to the correct ports at the shift knob.</li> <li>2. If the lines are correct, replace the shift knob.</li> </ol>
		No air flow from the disconnected line.	Go to step G.
Step G	Check for air coming out of the slave valve "P" port.	Air flows from this port.	Replace the slave valve.
		No air flow from this port.	Go to step H.



# Air System Troubleshooting

Table 15 No or Slow Range Shift into High

	Procedure	Result	What to do next
Step H	Place the shift lever in neutral. Install a 100 PSI pressure gauge in line with the "P" line. Move the range selector back and forth from low to high range. The gauge should show rapid pressure change.	The gauge responds slowly.	<ol style="list-style-type: none"> <li>1. Check for a restricted line between the shift knob and slave valve.</li> <li>2. Check for a restricted exhaust port on the shift knob.</li> <li>3. Check for a plugged or dirty filter in the filter/regulator assembly.</li> <li>4. Check for a pinched or obstructed 1/4" rubber air line between the filter/regulator and slave valve.</li> <li>5. Check for a pinched or obstructed air line between the slave valve and the "S" port on the shift knob.</li> <li>6. If all are good, replace the shift knob.</li> </ol>
		The gauge rapidly moves between 58-63 PSI and 0 PSI.	Go to step I.
Step I	<p>If possible, leave air lines attached to slave valve.</p> <p>Unbolt the slave valve from transmission side.</p> <p>Check for free movement of the plunger pin protruding from the case under the slave valve. The pin should extract when the transmission is shifted into gear and retract when shifted into neutral.</p> <p>If desired, the slave valve can be actuated and tested while unbolted from the transmission case. The air lines, of course, must remain attached.</p>	Actuating plunger pin does not move freely.	<ol style="list-style-type: none"> <li>1. Remove actuating plunger pin and check for damage.</li> <li>2. Check for missing or broken spring.</li> </ol>
		Actuating plunger pin moves freely.	Repair or replace slave valve and check for proper range operation.

Table 15 No or Slow Range Shift into High

	Procedure	Result	What to do next
Step R	<p>If air system has been tested and found to operate satisfactory, the auxiliary section must be removed to inspect for mechanical problem.</p> <p>Remove auxiliary section and inspect for:</p> <ul style="list-style-type: none"> <li>•Binding of range yoke bar or piston</li> <li>•Damaged or defective range yoke</li> <li>•Damaged or defective range synchronizer</li> <li>•Cracked countershaft weld resulting in gear turning on shaft</li> <li>•Damaged or defective range sliding clutch</li> <li>•Auxiliary section gearing out of time</li> </ul>		

# Air System Troubleshooting

---

## **Procedure 8: Symptom - Range Shifts with Shift Lever in Gear**

### **Normal Operation:**

Range shifts should only occur when the shift lever is in neutral. The range selector can be moved up or down while the shift lever is in a gear position, but the shift will not occur until the shift lever is moved to neutral.

### **Possible Causes:**

- Worn or missing actuating pin or air valve shaft
- Worn shift rail

### **Procedure:**

If the range has been confirmed to shift with the shift lever in gear, unbolt the slave valve from the side of the transmission. Confirm that the actuating pin is present and that it is the proper part number for the corresponding slave valve. If correct, remove the shift bar housing assembly and check for a worn or damaged air valve shaft or worn shift rails. Replace necessary parts.

## RTLO 10-Speed Troubleshooting

### Confirm Correct Components and Plumbing

- A-5454 Air Filter/Regulator on the range cylinder cover.
- 1/4 inch air hose from the air filter/regulator to the splitter cylinder cover (iron port).
- A red air line from the air filter/regulator to the tee in the range actuator valve "S" port on the shift bar housing.
- A red air line from the tee to the A-5510/A-6910 Roadranger valve "S" port.
- A black air line from the range actuator valve "P" port to the range cylinder.
- A blue air line from the Roadranger A-5510/A-6910 valve "SP" port to the splitter cylinder cover (brass port.)



**WARNING:** Prior to removing the air module, exhaust the air from it. Failure to exhaust the air module may result in personal injury or damage to parts from the sudden release of air.



**WARNING:** Use care when removing the test port pipe plugs. If air pressure is present on the plug, it can become a projectile during removal. When removing the "L" plug or "H" plug, pressure can be shut off by selecting the opposite range mode. If removing the "F" plug, exhaust the air to the module inlet.

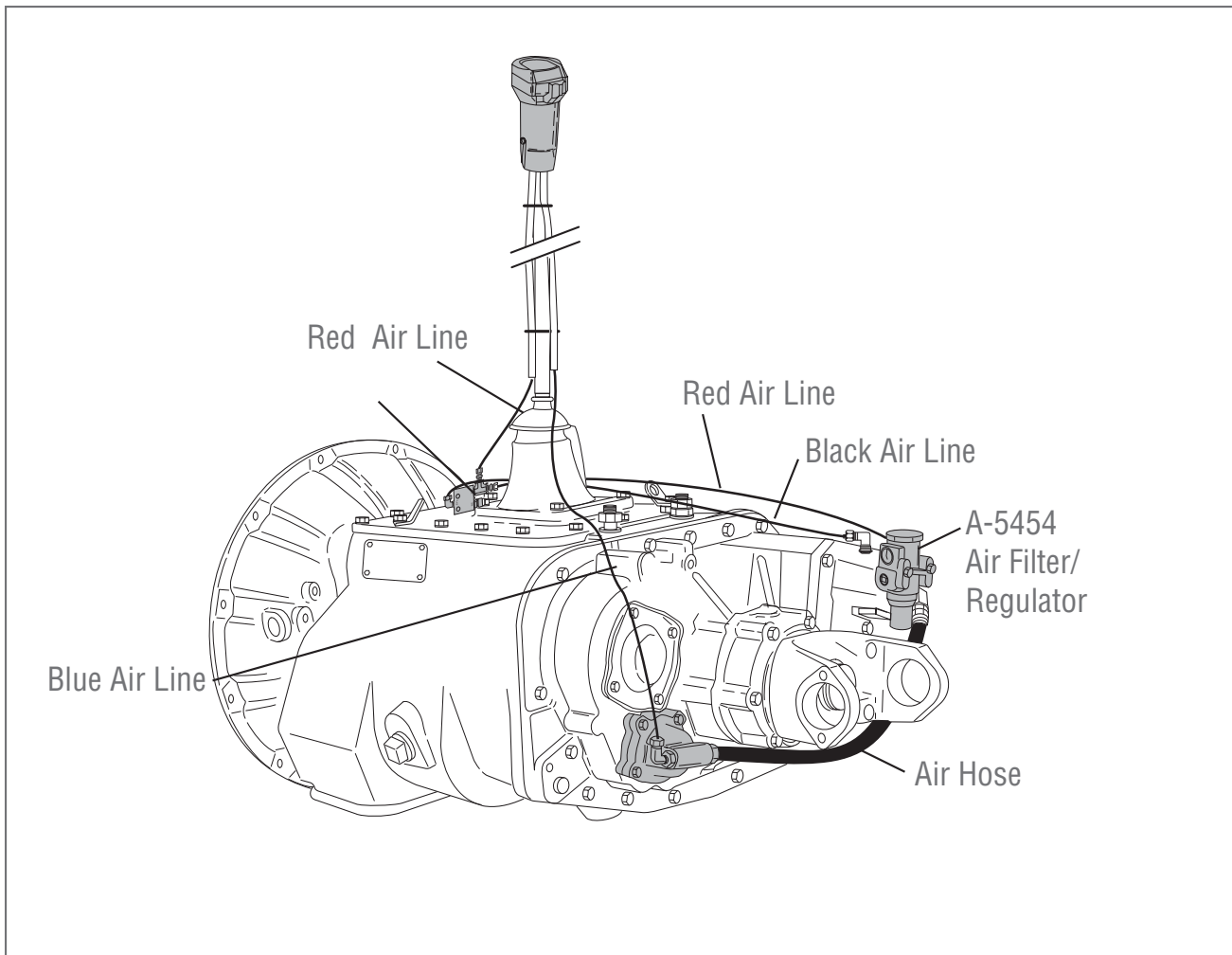

# Air System Troubleshooting

## Air Filter/ Regulator Test

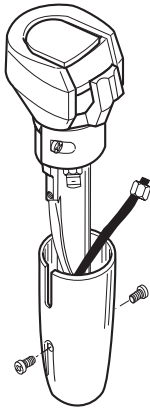

**Figure 1**

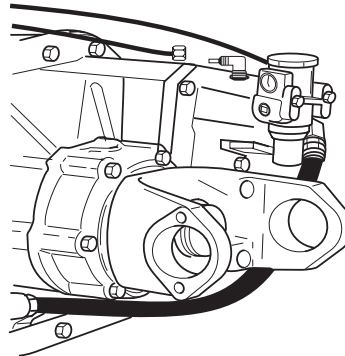

**Figure 2**

**Table 1 Air Filter/Regulator Test**

Step	Procedure	Result	What to do next
A	Place the transmission shift lever in neutral.		
B	Start the engine and wait for the air system pressure to reach governor cut off (90 to 125 PSI.)		
C	Turn the engine off.		
	If at any time during testing the truck's air pressure falls below 90 PSI; restart the engine, wait for air pressure to reach governor pressure, turn the engine off, and continue testing.		
D	Make sure the splitter control button is rearward.		
E	Remove the two (2) screws on the Roadranger valve cover and pull the cover down.		
F	Disconnect the blue air line from the "SP" port.		
G	Install the correct test fixture for your air line size in the "SP" line.		

Table 1 Air Filter/Regulator Test

Step	Procedure	Result	What to do next
H	Move the splitter control button forward to overdrive. The air pressure gauge should read between 58 and 63 PSI.	Air pressure is outside the 58 to 63 PSI range and the truck's air system pressure is 90 to 125 PSI.	Replace the A-5454 Filter/Regulator.
		Air pressure slowly comes up to between 58 and 63 PSI.	Inspect the red air line from the filter/regulator to the range actuator valve and the red air line from the range actuator valve to the A-5510/A-6910 Roadranger valve for restrictions
R	Remove the test fixture. Assemble the Roadranger valve.		

# Air System Troubleshooting

## Range System Test

If water or oil is found in an insert valve, remove both insert valves, the filter/regulator, the range cylinder cover, and the range piston. Clean everything and replace the range piston O-rings and range cylinder cover gasket. Apply silicone grease to the external range piston O-ring and the insert valve O-rings. Assemble and test.

**Note:** If you replace or repair any parts, return to Step A after completion

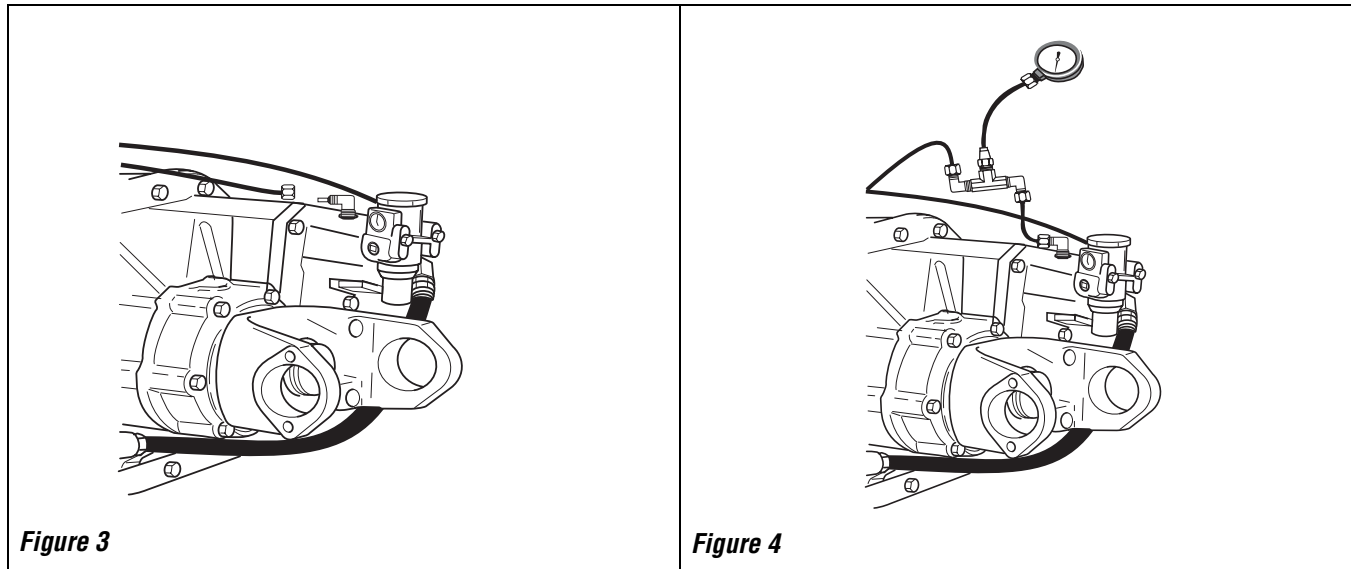

Table 2 Range System Test

Step	Procedure	Result	What to do next
A	Move the transmission shift lever in neutral away from the driver to the top gear rail position.		
B	Remove the black air line from the range cylinder cover.		
C	Check for air flow out of the black air line.	<p>There is no air flow from the black air line.</p> <p>There is air flow.</p>	<p>Go to step D.</p> <p>Check the range actuator valve retaining bolts. Tighten any loose bolts and check again for air flow. If air flow continues, remove the range actuator valve retaining bracket bolts. Push the button all the way into the valve. If air flow continues, replace the range actuator valve. If air flow stops when the range actuator valve is manually operated, remove the actuating pin (lift it out with a magnet). Check the pin for wear. It should be 1.029 to 1.032 inches long. If it is not, replace the pin. If the pin length is correct, refer to the service manual for shift bar housing inspection.</p>

Table 2 Range System Test

Step	Procedure	Result	What to do next
D	Check for air flow from the range cylinder port.	<p>There is no air flow from the port.</p> <p>There is air flow.</p>	<p>Go to step E.</p> <p>Remove the insert valve retaining plug from the range cylinder cover bottom. The insert valve will be blown out of the cover. Clean the insert valve, using compressed air and apply silicone grease to the external O-rings. Assemble and check for air flow from the port. If air flow persists, replace the insert valve.</p>
E	Install the correct test fixture, for your air line size, in the range cylinder port.		
F	Move the transmission shift lever toward the driver (center rail.) The air pressure should rapidly be between 58 and 63 PSI.	<p>Air pressure rapidly comes up to between 58 and 63 PSI.</p> <p>Air pressure does not rapidly come up to between 58 and 63 PSI.</p>	<p>Remove the test fixture and connect the black air line to the range cylinder. If air pressure does rapidly come up to between 58 and 63 PSI, remove the actuating pin (lift it out with a magnet). The pin should be between 1.029 and 1.032 inches long. If it is not, replace it. If the pin length is correct, refer to the service manual for shift bar housing inspection.</p> <p>Inspect the black air line from the range actuator valve "CYL" port for restrictions. If there are no restrictions, remove the range actuator valve retaining bolt. Push the button all the way into the valve and release it. If air pressure does not rapidly come up to between 58 and 63 PSI, replace the range actuator valve.</p>



# Air System Troubleshooting

Table 2 Range System Test

Step	Procedure	Result	What to do next
G	Listen for a range shift while moving the transmission shift lever from neutral to the top gear rail and back toward the driver into the center rail. If there is no range shift, move the transmission shift lever back and forth again and check for a momentary exhaust from the insert valve retaining plug in the range cylinder cover bottom.	There is no range shift and there is momentary exhaust from both insert valves.	Remove the range cylinder cover. If the piston is stuck from rust and contamination, remove the piston, clean the cylinder, replace the O-rings, and assemble. Clean the insert valve, use compressed air and apply silicone grease to the external O-rings. Assemble and test.
		There is no momentary exhaust.	Remove the insert valve retaining plug from the range cylinder cover bottom. The insert valve will be blown out of the cover. Clean the insert valve, use compressed air and apply silicone grease to the external O-rings. Assemble and test. If there is still no momentary exhaust, replace the insert valve.
		There is momentary exhaust.	Move the transmission shift lever in neutral back and forth again and check for momentary exhaust from the insert valve retaining plug on the range cylinder cover side. Continue to step I.
I	Move the transmission shift lever in neutral toward the driver to the center rail. Check both insert valve retaining plugs for continuous air flow from the exhaust port.	There is air flow.	Remove the insert valve retaining plug. The insert valve will be blown out of the cover. Clean the insert valve, use compressed air and apply silicone grease to the external O-rings. Assemble and check for air flow. If air flow persists, replace the insert valve. If air flow persists with a new insert valve, remove the range cylinder cover and inspect the range piston O-rings for damage or contamination and the range piston for cracks.
		There is no air flow.	Go to step J.
J	Move the transmission shift lever in neutral away from the driver to the top gear rail. Check both insert valve retaining plugs for continuous air flow from the exhaust port.	There is air flow.	Remove the insert valve retaining plug. The insert valve will be blown out of the cover. Clean the insert valve, use compressed air and apply silicone grease to the external O-rings. Assemble and check for air flow. If air flow persists, replace the insert valve.
		There is no air flow.	Go to step K.

**Table 2 Range System Test**

Step	Procedure	Result	What to do next
K	With the transmission shift lever in neutral, toward the driver in the center rail, remove the breather or breather hole plug on the shift bar housing. Check for air flow from the hole in the shift bar housing. If there is airflow move the transmission shift lever in neutral, away from the driver, to the top gear rail.	Air flow stopped.	Refer to the service manual and replace the range piston shaft to range cylinder O-ring.
		Air flow did not stop.	Refer to the service manual and replace the splitter piston shaft to splitter cylinder O-ring.
R	If the insert valves were not removed and cleaned during the test, remove them now (remove the insert valve retaining plugs.) The insert valves will be blown out the cover. Clean the insert valve, use compressed air and apply silicone grease to the external "O" rings. Assemble and test. The range portion of the test is now complete.		

# Air System Troubleshooting

## Splitter System Test

If you replace or repair any parts , return to Step A after completion

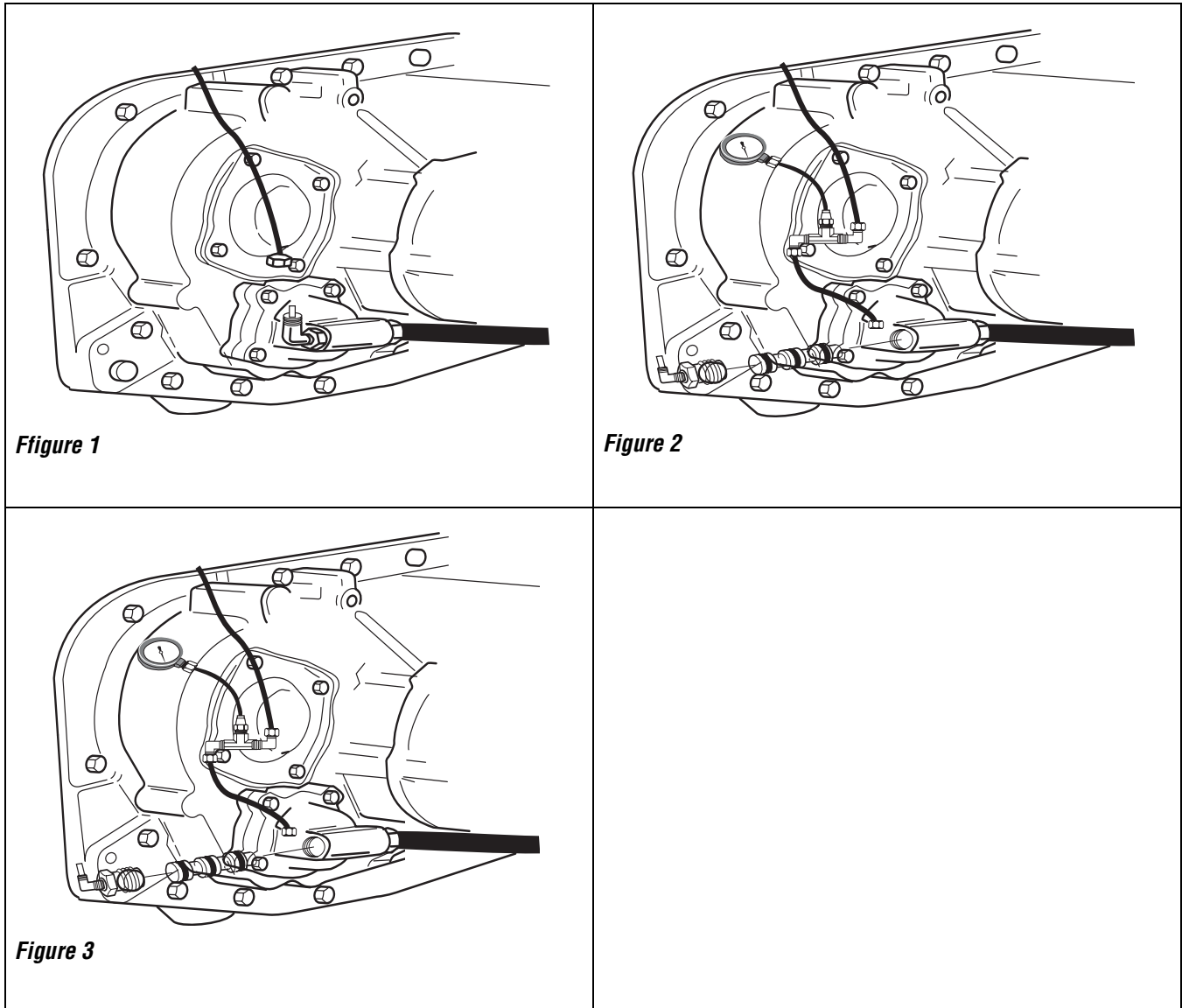

Table 3 Splitter System Test

Step	Procedure	Result	What to do next
A	Wipe off the area around the insert valve exhaust port.		
B	Move the control button back and forth several times to clear the exhaust port.		
C	Make sure the control button is rearward. Loosen the control air line retaining nut at the splitter cylinder.		

**Table 3 Splitter System Test**

Step	Procedure	Result	What to do next
D	Remove the loosened control air line and check for air flow from the cylinder fitting.	There is no air flow.	Go to step E.
		There is air flow.	Remove the insert valve and clean using compressed air. Then apply silicone grease to the o-rings and recheck for airflow.
E	Install, between the control line and the cylinder fitting, the correct test fixture for your air line size.		
F	Move the control button forward.	Air pressure rapidly changes to between 58 and 63 PSI and the truck's air system is 90 to 125 PSI.	Go to next step G.
		Air pressure does not change to between 58 and 63 PSI and the truck's air system is 90 to 125 PSI.	Inspect the control air line for restrictions.
G	Check the insert valve exhaust port for leakage.	No leakage is detected.	Go to next step H.
		Leakage is detected.	Go to Step L.
H	Move the control button rearward and listen for the shift.	There is a shift.	Go to next step I.
		There is no shift or a delayed shift.	Go to Step L.
I	Check the exhaust port for leakage.	No leakage is detected.	Go to next step J.
		Leakage is detected.	Go to Step L.
J	Move the control button forward and listen for the shift.	There is a shift.	Go to next step K.
		There is no shift or a delayed shift.	Go to Step L.
K	If there is air pressure at the control line, move the control button rearward and remove the test fixture. Connect the control line to the cylinder.		
L	Remove the insert valve retaining plug. The insert valve will be blown out of the cover (note valve orientation.)	There is no water and/or oil blown out.	Go to next step M.
		Water and/or oil is blown out.	Remove the cylinder cover and clean the cover and cylinder. Replace the cylinder cover gasket with a new gasket. Install cover.
M	Clean insert valve using compressed air.		

# Air System Troubleshooting

Table 3 Splitter System Test

Step	Procedure	Result	What to do next
N	Install the insert valve, as noted in Step L, and replace the retaining plug.		
O	Check the insert valve exhaust port for leakage.	No leakage is detected.	Go to next step P.
		Leakage is detected.	Replace the insert valve.
P	Move the control button forward and listen for the shift.	There is a shift.	Go to next step Q.
		There is no shift or a delayed shift.	Replace the insert valve.
Q	Check the insert valve exhaust port for leakage.	No leakage is detected.	Go to next step R.
		Leakage is detected.	Replace the insert valve.
R	Move the control button rearward and listen for the shift	There is a shift.	Go to next step S.
		There is no shift or a delayed shift.	Replace the insert valve.
S	Check the insert valve exhaust port for leakage.	No leakage is detected.	Go to next step T.
		Leakage is detected.	Disassemble (see service manual) and inspect splitter/reduction piston O-ring and piston to shaft seal.
T	Move the control button forward and listen for the shift.	There is a shift.	Go to next step V.
		There is no shift or a delayed shift.	Disassemble (see service manual) and inspect splitter/reduction piston O-ring and piston to shaft seal.
V	The air system test procedure is now complete and the air system has been confirmed to be operating correctly. If performance irregularities persist, they are not caused by the air system.		

## Combination Cylinder Troubleshooting

The symptoms listed below are covered on the following pages. Before beginning any of those troubleshooting procedures, place the transmission in neutral and move the range selection lever from low to high. Listen for any constant air leak from the shift knob, air module base (exhaust), or transmission breather. If a constant leak is heard, go to that particular leak troubleshooting procedure first.

If you do not see the symptom you need to correct, refer to the General Troubleshooting chart.

### Symptom

- Air Leak from Air Module Base (Exhaust Leak)
- No or Slow Range Shift into High (Shift into low range is good)
- No or Slow Range Shift into Low (Shift into high range is good)
- Constant Air Leak from Shift Knob
- Range Shifts in Gear
- Air Leak from Transmission Breather or Transmission Case is Pressurized

Note: Use the air system troubleshooting procedures for part replacement only if the symptom can be duplicated. If the problem is intermittent, parts that are not defective could be replaced.

Note: During all testing, the vehicle air pressure must be greater than 90 PSI (620 kPa). If during testing the pressure falls below 90 PSI (620 kPa), make sure the transmission is in neutral, start the engine and let the pressure build to governor cutoff. After the pressure reaches the governor cutoff, continue testing. The pressure is critical if the vehicle is equipped with a vehicle air system Pressure Protection Valve that would shut off the air supply to certain air circuits if the system pressure dropped below a preset level.

Note: A 0-150 PSI (0-1034 kPa) air gauge with a 1/16" male pipe thread fitting attachment is required for some of the test procedures.



**WARNING:** Prior to removing the air module, exhaust the air from it. Failure to exhaust the air module may result in personal injury or damage to parts from the sudden release of air.



**WARNING:** Use care when removing the test port pipe plugs. If air pressure is present on the plug, it can become a projectile during removal. When removing the "L" plug or "H" plug, pressure can be shut off by selecting the opposite range mode. If removing the "F" plug, exhaust the air to the module inlet.

# Air System Troubleshooting

## Procedure 1: Symptom - Air Leak at Shift Knob

### Normal operation:

A burst of air will be exhausted from the shift knob when moving the range selector from low to high. This is the air being exhausted from the "P" air line.

A burst of air will be exhausted from the shift knob when moving the deep reduction button rearward (shifting out of deep reduction). This is the air being exhausted from the "SP" air line.

### Possible causes:

- Incorrectly attached air lines
- Internal leak in slave valve
- Internal leak at insert valve
- Internal leak at shift knob

Table 1 Air Leak at Shift Knob

	Procedure	Result	What to do next
Step A	Remove lower skirt on shift knob. Check for leaking fitting at the shift knob.	Leak found.	Repair leaking fitting or air line.
		No leak found.	Go to step B.
Step B	Check air lines to make sure all lines are connected to the proper ports on the shift knob. Reversal of "S" and "P" lines will result in a constant leak from the exhaust when high range is selected. Reversal of the H/L and "SP" lines will result in a constant leak when the deep reduction button is rearward.	Air lines are not connected to the proper ports.	Connect lines properly.
		Air lines are connected to proper ports.	Go to step C.
Step C	Move the range selector lever down to Low range. Check for constant air flow from the exhaust "E" port.	Constant air flow from "E" port.	Replace knob.
		No air flow from "E" port.	Go to Step D.
Step D	Move the range selector up to high range. Disconnect the small air line connected to the "P" port of the shift knob. Check for air flow from the port and air line.	Constant air is leaking from the "P" port or the "E" port.	Repair or replace the shift knob.
		Air is coming out of the disconnected air line.	1. Verify that the air line is connected to the slave valve "p" port. 2. If properly connected, replace the slave valve.
		Air is not leaking from either port or disconnected air line.	Go to Step E.





# Air System Troubleshooting

## Procedure 2: Symptom - Air Leak at Slave Valve

### Normal operation:

A momentary exhaust of air at the slave valve occurs during a range shift. The air from the low side of the range cylinder is exhausted as air pressure is applied to the high range side. Likewise, air from the high range side of the piston is exhausted as air pressure is applied to the low range side. The exhaust port is located at the slave valve to transmission mounting interface.

### Possible Causes:

- Internal leak in range cylinder
- Internal leak in slave valve.

Table 2 Air Leak at Slave Valve

	Procedure	Result	What to do next
Step A	Confirm that air is leaking from the exhaust port on the slave valve and not a fitting or air line.	Air is leaking from fitting or air line.  Air is definitely leaking from slave valve exhaust port.	Repair or replace fitting or air line.  Go to Step B.
Step B	Move range selector down to select low range. Remove the 1/4" I.D. rubber air line at the high range supply port on the range cylinder. Feel for air flow from the open port on the range cylinder. Note: If the air leak at the slave valve only occurs when the transmission is in high range, repeat the above test, but remove the low range air hose and check with high range selected.	Air is flowing from high range supply port on range cylinder.  No air flow from high range port.	Remove range cylinder cover and repair leaking range piston or piston seal. After repair, check for proper range operation.  Repair or replace slave valve.

## Procedure 3: Symptom - Air Leak from Transmission Breather or Transmission Case is Pressurized

**Normal Operation:**

There should be no measurable air flow from the transmission breather.

**Possible causes:**

- Leak at range yoke bar O-ring
- Leak at deep reduction yoke bar O-ring

Table 3 Air Leak from Transmission Breather or Transmission Case is Pressurized

	Procedure	Result	What to do next
Step A	Listen for the air leak with the transmission shifted to both low and high range.	Leak is only in low range.	Remove range cylinder and inspect for damaged range yoke bar, yoke bar O-ring, or range cylinder. Repair as necessary.
		Leak is in both low and high range.	Remove deep reduction cylinder. Inspect for damaged deep reduction yoke bar, O-ring, or cylinder. Repair as necessary.

# Air System Troubleshooting

---

## Procedure 4: Symptom: Air Leak at Deep Reduction Cylinder Cover Exhaust Port

**Normal operation:**

A burst of air will exhaust from this port when shifting into deep reduction (the deep reduction button is moved forward while in low range).

**Possible causes:**

- Damaged/defective insert valve
- Leak past insert valve external O-rings
- Leak past deep reduction cylinder piston

Table 4 Air Leak at Deep Reduction Cylinder Cover Exhaust Port

	Procedure	Result	What to do next
Step A	Remove insert valve. Check for contamination, damaged seals, or sticky movement. Check the insert valve bore in the deep reduction cylinder cover for contamination or damage which would result in leakage past the insert valve O-rings.	Contamination or damage found.	Repair or replace as necessary.
		No contamination or damage found.	Go to step B.
Step B	Remove the deep reduction cylinder cover and piston. Check the piston bore for contamination or damage. Check the piston seals for damage. NOTE: Early production transmissions used a paper gasket to seal the piston to the yoke bar, if necessary, replace this configuration with the current design which uses an O-ring.	Contamination or damage found.	Repair or replace as necessary.

## Procedure 5: Symptom - No or Slow Range Shift into Low

### Normal Operation:

When the range selector on the shift knob is moved down to select low range, air pressure will flow through the shift knob to the 'P' port on the slave valve. The slave valve will direct air pressure through the low range 1/4" rubber hose to the range cylinder to shift the range. There will be a brief burst of air at the slave valve as the high range side of the range piston exhausts. Likewise, when high range is selected, the air pressure in the "P" will be exhausted at the shift knob. This will cause the slave valve to direct air to the rear side of the range cylinder piston. The air pressure on the low range side will be exhausted at the slave valve.

### Possible Causes:

- Incorrect air line hook up
- Insufficient air supply to transmission
- Damaged or defective air filter / regulator assembly
- Damaged or defective shift knob master valve
- Damaged or defective slave valve
- Damaged or defective range cylinder
- Damaged or defective range yoke or yoke bar
- Damaged or defective range synchronizer
- Damaged or defective gearing in auxiliary section of transmission

Table 5 No or Slow Range Shift into Low

	Procedure	Result	What to do next
Step A	Place the shift lever in neutral. Check for constant air leakage at the shift knob, slave valve, and transmission case breather when both low and high range have been selected.	Constant air leak is detected.	Go to the other corresponding symptom first. See beginning of Air System Troubleshooting section.
		No constant leak is detected.	Go to step B.
Step B	Place shift lever in neutral. Move range selector up to high range position. At the rear of the transmission, disconnect the 1/4" rubber air line from the low range supply port on the range cylinder. Check for air flow from the low range port.	Air flows from the low range port.	Remove range cylinder cover and repair leaking range piston or piston seal.
		No air flow from low range port.	Go to step C.
Step C	Check for air flow from the disconnected air line.	Air flows from disconnected air line.	Go to step F.
		No air flow from disconnected line.	Go to step D.

# Air System Troubleshooting

Table 5 No or Slow Range Shift into Low

	Procedure	Result	What to do next
Step D	Install a 100 PSI air gauge in the disconnected air line end. With the shift lever in neutral, move the range selector down to select low range and observe the gauge.	The gauge read 0 PSI.	Go to step F.
		The gauge reads pressure but is lower than 58 PSI or higher than 63 PSI.	Replace the filter/regulator and check for proper range operation.
		The gauge reads between 58 - 63 PSI.	Go to step E.
Step E	Confirm that shift lever is still in neutral. Have an assistant move the range selector up and down between low and high range. Does the pressure measured at the gauge respond rapidly when going from high to low.	Pressure rapidly changes between 58-63 PSI and 0 at the gauge.	Air system appears to be operating satisfactory. Go to step R.
		Pressure does not change rapidly at gauge.	<ol style="list-style-type: none"> <li>1. Check for a plugged or dirty filter in the filter/regulator assembly.</li> <li>2. Check for a pinched or obstructed 1/4" rubber air line between the filter/regulator and slave valve.</li> <li>3. Check for a pinched or obstructed 1/4" rubber air line between the slave valve and the test gauge.</li> <li>4. If all are satisfactory, go to step F.</li> </ol>
Step F	Place shift lever in neutral. At the shift knob, move the range selection lever up to select high range. At the slave valve, remove the air line from the "P" port (should be black line). Check for air flow from the disconnected line.	Air flows from the disconnected line.	<ol style="list-style-type: none"> <li>1. Confirm that the air lines are connected to the correct ports at the shift knob.</li> </ol>
		No air flow from the disconnected line.	<ol style="list-style-type: none"> <li>2. If the lines are correct, replace the shift knob.</li> </ol> Go to step G.
Step G	Check for air flow from the "P" portion the slave valve.	Air flows from this port.	Replace the slave valve.
		No air flow from this port.	Continue to step H.



# Air System Troubleshooting

---

Table 5 No or Slow Range Shift into Low

	Procedure	Result	What to do next
Step R	<p>If air system has been tested and found to operate satisfactory, the auxiliary section must be removed to inspect for mechanical problem. Remove auxiliary section and inspect for:</p> <ul style="list-style-type: none"> <li>•Binding of range yoke bar or piston</li> <li>•Damaged or defective range yoke</li> <li>•Damaged or defective range synchronizer</li> <li>•Cracked c/s weld resulting in gear turning on shaft</li> <li>•Damaged or defective range sliding clutch</li> <li>•Auxiliary section gearing out of time.</li> </ul>		

## Procedure 6: Symptom - No or Slow Range Shift into High

### Normal Operation:

When the range selector on the shift knob is moved down to select low range, air pressure will flow through the shift knob to the 'P' port on the slave valve. The slave valve will direct air pressure through the low range 1/4" rubber supply hose to the range cylinder to shift the range. There will be a brief burst of air at the slave valve as the high range side of the range piston exhausts. Likewise, when high range is selected, the air pressure in the "P" will be exhausted at the shift knob. This will cause the slave valve to direct air to the rear side of the range cylinder piston. The air pressure on the low range side will be exhausted at the slave valve.

### Possible Causes:

- Incorrect air line hook up
- Insufficient air supply to transmission
- Plugged filter
- Incorrect regulator pressure
- Damaged or defective shift knob master valve
- Damaged or defective slave valve
- Damaged or defective range cylinder
- Damaged or defective range yoke or yoke bar
- Damaged or defective range synchronizer
- Damaged or defective gearing in auxiliary section of transmission

Table 6 No or Slow Range Shift into High

	Procedure	Result	What to do next
Step A	Place the shift lever in neutral. Check for constant air leakage at the shift knob, slave valve, and transmission case breather when both low and high range have been selected.	Constant air leak is detected.	Go to the above corresponding symptom first. See beginning of Air System Troubleshooting section.
		No constant leak is detected.	Go to step B.
Step B	Place shift lever in neutral. Move range selector down to low range position. At the transmission rear, disconnect the 1/4" rubber air line from the range cylinder high range supply port. Check for air flow from the cylinder high range port.	Air flows from the high range port.	Remove range cylinder cover and repair leaking range piston or piston seal. After repair, check for proper range operation.
		No air flow from high range port.	Go to step C.
Step C	Check for air flow from the disconnected air line.	Air flows from disconnected air line.	Go to step F.
		No air flows from disconnected line.	Go to step D.



# Air System Troubleshooting

Table 6 No or Slow Range Shift into High

	Procedure	Result	What to do next
Step D	Install a 100 PSI air gauge in the disconnected air line end. With the shift lever in neutral, move the range selector up to select high range. Observe the gauge.	The gauge reads 0 PSI.	Go to step F.
		The gauge reads pressure but is lower than 58 PSI or higher than 63 PSI.	Replace the filter/regulator and check for proper range operation.
		The gauge reads between 58-63 PSI.	Go to Step E.
Step E	Confirm that a shift lever is still in neutral. Have an assistant move the range selector up and down between low and high range. Does the pressure measured at the gauge respond rapidly when going from low to high to low.	Pressure rapidly changes between 58-63 PSI and 0 at the gauge.	Air system appears to be operating satisfactory. Go to Step R.
		Pressure does not respond rapidly at gauge.	<ol style="list-style-type: none"> <li>1. Check for a plugged or dirty filter in the filter/regulator assembly.</li> <li>2. Check for a pinched or obstructed 1/4" rubber air line between the filter/regulator and slave valve.</li> <li>3. Check for a pinched or obstructed 1/4" rubber air line between the slave valve and the test gauge.</li> <li>4. If all are satisfactory, Go to Step F.</li> </ol>
Step F	Place shift lever in neutral. At the shift knob, move the range selector up to select high range. At the slave valve, remove the air line from the "P" port (should be black line). Check for air flow from the disconnected line.	Air flows from the disconnected line.	<ol style="list-style-type: none"> <li>1. Confirm proper air line hook-up at the shift knob.</li> </ol>
		No air flow from the disconnected line.	<ol style="list-style-type: none"> <li>2. If correct hook-up, replace the shift knob.</li> </ol> Go to Step G.
Step G	Check for air coming out of the slave valve "P" port.	Air flows from this port.	Replace the slave valve.
		No air flow from this port.	Continue to Step H.



# Air System Troubleshooting

---

Table 6 No or Slow Range Shift into High

	Procedure	Result	What to do next
Step R	<p>If air system has been tested and found to operate satisfactory, the auxiliary section must be removed to inspect for mechanical problem. Remove auxiliary section and inspect for:</p> <ul style="list-style-type: none"><li>•Binding of range yoke bar or piston</li><li>•Damaged or defective range yoke</li><li>•Damaged or defective range synchronizer</li><li>•Cracked c/s weld resulting in gear turning on shaft</li><li>•Damaged or defective range sliding clutch</li><li>•Auxiliary section gearing out of time.</li></ul>		

## Procedure 7: Symptom - No or Slow Shift into Deep Reduction

### Normal Operation:

When the deep reduction button is moved forward to select deep reduction, air pressure is supplied through the “SP” air line to the insert valve signal port. This air pressure causes the insert valve to exhaust the air pressure on the rear of the deep reduction piston and the piston moves rearward. A burst of air occurs at the deep reduction cylinder exhaust port as this air is exhausted from the piston back side. A burst of air also occurs at the shift knob when the deep reduction button is moved rearward. This is the signal air being exhausted out of the “SP” line.

### Possible causes:

- Incorrect air line hook up, Plugged filter.
- Incorrect regulator pressure. Insufficient air supply to transmission.
- Damaged or defective shift knob master valve.
- Damaged or defective deep reduction insert valve.
- Damaged or defective deep reduction piston or cylinder.
- Damaged or defective deep reduction yoke bar or yoke.
- Damaged or defective deep reduction sliding clutch or gearing.

Note: Before completing the following troubleshooting procedure, move the deep reduction button both rearward and forward and check for constant exhaust air at either the shift knob or deep reduction cylinder exhaust port. If a constant leak is noticed, go to that troubleshooting procedure first. In addition, confirm that the low and high range shifts are occurring properly. If not, go to the appropriate range shift troubleshooting procedure before completing the following procedure.

Table 7 No or Slow Shift into Deep Reduction

	Procedure	Result	What to do next
Step A	Move range selector down to select low range. Move the deep reduction button rearward. At the deep reduction cylinder on the transmission back, remove the small air line which provides the signal to the insert valve (SP line). Make sure this line was connected to the proper port location on the cylinder cover. Check for air flow from the line.	Air flows from the disconnected line.	Go to Step K.
		No air flow from disconnected line.	Go to Step B.
Step B	Connect a 100 PSI pressure gauge to the disconnected signal port line. Move the deep reduction button forward. Read the pressure on the gauge.	Gauge reads 0 PSI.	Go to Step F.
		Gauge reads pressure, but is lower than 58 PSI or higher than 63 PSI.	Replace filter / regulator assembly.
		Gauge reads between 58 PSI and 63 PSI.	Go to Step C.

# Air System Troubleshooting

Table 7 No or Slow Shift into Deep Reduction

	Procedure	Result	What to do next
Step C	Have an assistant move the deep reduction button forward and rearward. Observe the pressure gauge.	Pressure rapidly changes between 58-63 PSI and 0 PSI at the gauge.	Go to Step D.
		Pressure does not respond rapidly at gauge.	Go to Step F.
Step D	Remove the insert valve. NOTE: After the insert valve plug has been removed, cover the opening with a shop rag and apply shop air to the signal line port to blow the insert valve out of it's bore. Catch the valve with the shop rag. If the vehicle air pressure is still present, constant air flow should be blowing out of the insert valve bore. Inspect the insert valve for contamination or damage. Make sure the small piston inside the valve can freely move 1/32".	Insert valve is contaminated, sticking, or damaged.	Replace insert valve, reconnect air line, and check if deep reduction shifts normally.
		Insert valve is clean and small internal piston moves freely.	Go to step E.
Step E	Remove the deep reduction cylinder cover and deep reduction piston. Inspect piston and bore for contamination or damage.	Deep reduction cylinder bore or piston is contaminated or damaged.	Repair as necessary, replace insert valve and air line. Check if deep reduction shifts normally
		Deep reduction cylinder bore or piston is in good condition.	<ol style="list-style-type: none"> <li>1. Remove deep reduction cylinder assembly. Inspect for contamination or damage causing deep reduction yoke bar to bind in cylinder. Repair as necessary.</li> <li>2. Remove auxiliary section and inspect deep reduction yoke, sliding clutch, and gearing for damage which would prevent deep reduction shift. Repair as necessary.</li> </ol>

**Table 7 No or Slow Shift into Deep Reduction**

	Procedure	Result	What to do next
Step F	At the shift knob, remove the two screws attaching the lower cover, and slide the lower cover down to access the fittings. Confirm that the air lines are connected to the proper ports. Make sure the shift lever is in neutral. Move the range selector down to select low range, and move the deep reduction button rearward. Disconnect the air line connected to the "SP" port. Check for air flow from the "SP" port.	Air flows from "SP" port.	Replace shift knob.
		No air flow from "SP" port.	Go to Step G.
Step G	Move deep reduction button forward. Check for air flow from "SP" port.	Air flows from "SP" port.	<ol style="list-style-type: none"> <li>1. Check for proper air line connection from "SP" port on shift knob to "SP" port on deep reduction cylinder.</li> <li>2. Check for obstruction in "SP" air line or fittings.</li> <li>3. If clear, reconnect the air line at the shift knob, go to step A.</li> </ol>
		No air flow from "SP" port.	Go to step H.
Step H	Disconnect air line H/L port on shift knob. Check for air flow from the disconnected line.	Air flows from disconnected line.	Replace shift knob.
		No air flow from disconnected line.	<ol style="list-style-type: none"> <li>1. Check to make sure that the shift lever is in neutral, the range selector is down in low range and the "H/L" line is properly connected to the low range hose at the slave valve.</li> <li>2. If no air pressure is available on low range hose, perform low range shift troubleshooting procedure to correct this problem.</li> </ol>

# Air System Troubleshooting

---

## **Procedure 8: Symptom - Range Shifts with Shift Lever in Gear**

### **Normal Operation:**

Range shift should only occur when the shift lever is in neutral. The range selector can be moved up or down while the shift lever is in a gear position, but the shift will not occur until the shift lever is moved to neutral.

### **Possible Causes:**

- Worn or missing actuating pin or air valve shaft.
- Worn shift rail

### **Procedure:**

If the range has been confirmed to shift with the shift lever in gear, unbolt the slave valve from the side of the transmission. Confirm that the actuating pin is present and that it is the proper P/N for the corresponding slave valve. If correct, remove the shift bar housing assembly and check for a worn or damaged air valve shaft or worn shift rails. Replace necessary parts.

## FR-1X210 Troubleshooting

The symptoms listed below are covered on the following pages. Before beginning any of those troubleshooting procedures, place the transmission in neutral and move the range selection lever from low to high. Listen for any constant air leak from the shift knob, air module base (exhaust), or transmission breather. If a constant leak is heard, go to that particular leak troubleshooting procedure first. If you do not see the symptom you need to correct, refer to the General Troubleshooting chart at the beginning of this section.

### Symptom

- Air leak from Air Module Base (Exhaust leak)
- No or Slow Range Shift into High (Shift into low range is good)
- No or Slow Range Shift into Low (Shift into high range is good)
- Constant Air Leak from Shift Knob
- Range Shifts While Transmission is in Gear
- Air Leak from Transmission Breather or Transmission Case is Pressurized

**Note:** Use the air system troubleshooting procedures for part replacement only if the symptom can be duplicated. If the problem is intermittent, parts that are not defective could be replaced.

**Note:** During all testing, the vehicle air pressure must be greater than 90 PSI (620 kPa). If during testing the pressure falls below 90 PSI (620 kPa), make sure the transmission is in neutral, start the engine and let the pressure build to governor cutoff. After the pressure reaches the governor cutoff, continue testing. The pressure is critical if the vehicle is equipped with a Pressure Protection Valve that would shut off the air supply to certain air circuits if the system pressure dropped below a preset level.

**Note:** A 0-150 PSI (0-1034 kPa) air gauge with a 1/16" male pipe thread fitting attachment is required for some of the test procedures.

**Note:** Regulated air pressure is 75 to 85 PSI (517-586 kPa).



**WARNING:** Prior to removing the air module, exhaust the air from it. Failure to exhaust the air module may result in personal injury or damage to parts from the sudden release of air.



**WARNING:** Use care when removing the test port pipe plugs. If air pressure is present on the plug, it can become a projectile during removal. When removing the "L" plug or "H" plug, pressure can be shut off by selecting the opposite range mode. If removing the "F" plug, exhaust the air to the module inlet.



# Air System Troubleshooting

## Air System Nomenclature

Figures 4-1 through 4-3 below show the air module, shift knob, and range alignment lock cover (earlier models) with their components labeled. These are the primary components used during troubleshooting. If necessary, refer to these figures while troubleshooting the air system.

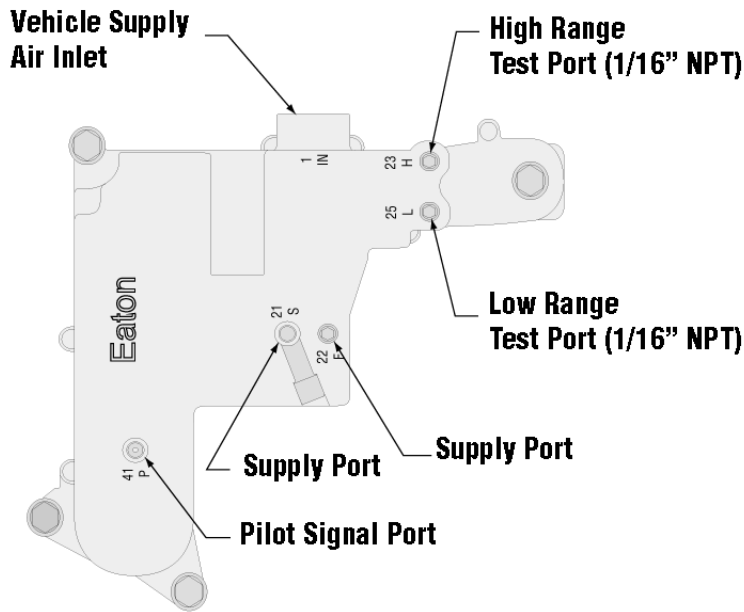

Figure 4-1 Air Module Ports

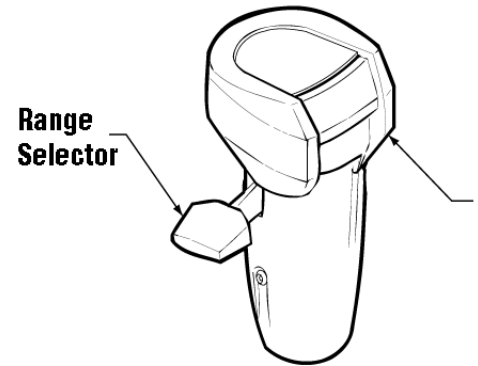

Figure 4-2 Shift Knob Component

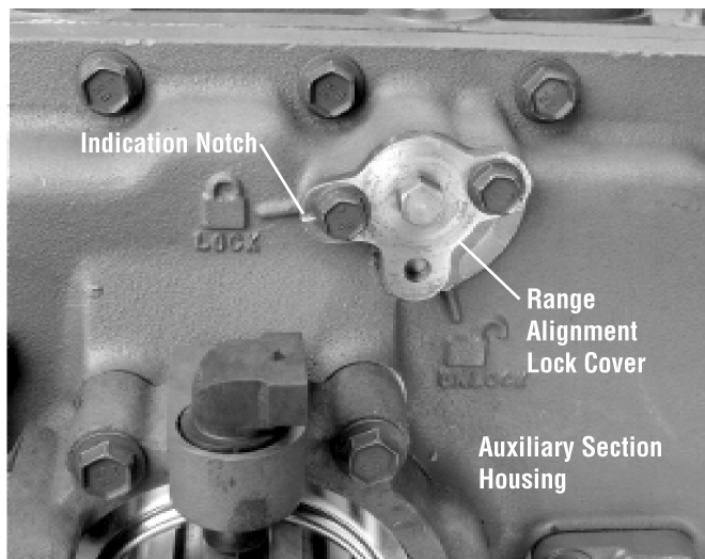
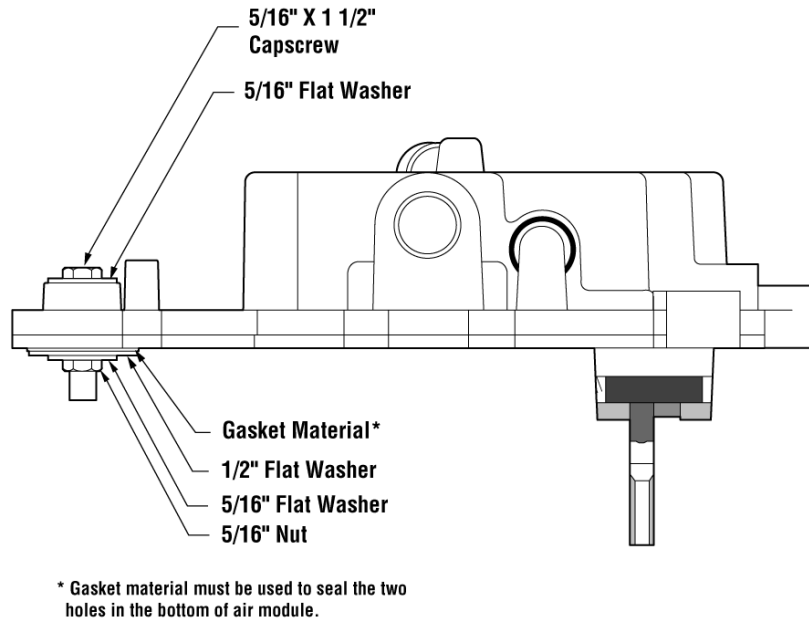

Figure 4-3 Range Alignment Lock Cover

Figure 4-4 below shows how to isolate the air module. If necessary, refer to this figure when isolating the air module.



**Figure 4. Air module Isolation**

**Figure 4-4 Air Module Isolation**

The table below shows which air lines connect to which ports on the shift knob and air module. If necessary, refer to this table when connecting the air lines.

Port on Knob	Port on Air Module	Air Line Color (Typical)
S	S	Red
P	P	Black

# Air System Troubleshooting

## Air System Symptom - Air Leak from Module Base (Exhaust)

Short bursts of air leakage from the module base (exhaust) are normal as the range system is shifted. The module base is defined as both the interface of the module cover and module base and the extreme underside of the module. Leakage is a problem when it is audible and constant. Air leakage from the module base may result from either a defective air module or a defective range piston. The following procedure will identify the defective component.

### Test Procedure:

1. Check for air leakage from the module base (exhaust) in each of the four following conditions. (Make sure the range is shifted when the shift lever is in neutral.)
  - a. Range selection lever in Low and shift lever in neutral.
  - b. Range selection lever in Low and shift lever in gear.
  - c. Range selection lever in High and shift lever in neutral.
  - d. Range selection lever in High and shift lever in gear.

Record the findings (constant leak or no leak) in the following table.

	Range Selector in LOW	Range Selector in HIGH
Lever in Neutral		
Lever in Gear		

2. If the information you recorded at step 1 matches one of the following tables, replace the air module. If your table does not match either of the tables, it will be necessary to isolate and test the air module separately, continue to step 3.

	Range Selector in LOW	Range Selector in HIGH
Lever in Neutral	No Leak	Constant Leak
Lever in Gear	No Leak	Constant Leak

	Range Selector in LOW	Range Selector in HIGH
Lever in Neutral	Constant Leak	Constant Leak
Lever in Gear	Constant Leak	Constant Leak



**WARNING:** Failure to exhaust the air pressure may cause personal injury or damage to parts.

3. Exhaust the air pressure from the air module. To do so, the vehicle's air tanks may need to be exhausted.
4. Leaving all air lines connected to the module, remove the four capscrews attaching the air module to the shift bar housing. Lift the air module and tilt it to gain access to the two air holes at the underside on the rear capscrew location. Do not damage or lose the two o-rings used to seal the holes.
5. Block off the air ports on the underside of the module. Use a piece of gasket material or rubber material to seal the bottom of the module as shown in Figure 4-1 under "Air System Nomenclature".
6. Repressurize the air module with an inlet supply pressure of over 90 PSI (620 kPa). To repressurize the air module, the vehicle may need to be started and air pressure allowed to build up.
7. Check for air leakage in both high and low range. If air continues to leak constantly from the exhaust, the air module is defective. If air does not leak, a range cylinder piston or piston seal failure has occurred. Remove the shift bar housing to gain access to the range shift cylinder.

## Air System Symptom - No or Slow Range Shift into High (Shift into Low Range is Good)

This transmission contains a SynchroSaver feature to protect the high range synchronizer. When high range is selected and a front section gear is engaged, air pressure is supplied to both sides of the range piston, which reduces synchronizer force. Therefore, if the driver engages a front section gear before the high range synchronizer engages, the high range synchronizer will remain in neutral. When a front section gear engages before the synchronizer shift completes, the driver must shift the lever back to neutral to allow the high range synchronizer to complete its shift. Once the range shift is complete, the driver can complete the front section shift.

If the high range synchronizer hangs up or is slow to synchronize, the front section may engage first. The driver complaint will be that the transmission “neutralizes” on a shift to high range. If this condition occurs, perform the following test of the air system to eliminate the air system as the source of the problem. If the air system performs properly, then the problem is internal to the transmission range synchronizer system.

**Note:** The driver must preselect all range shifts.

**Note:** If a capscrew or stud is installed too far into the right side (air module side) rear support hole, the fastener can extend too far into the transmission. The fastener may contact the range yoke and bind the range synchronizer assembly during the range shift.

### Test Procedure

1. Check the shift knob operation.

On the shift knob, remove the screws holding the plastic skirt. Slide the skirt down and out of the way. Move the range selection lever up into high range. Disconnect the black line connected to the “P” port on the knob.

Question	Result	What to do next
Does air come out of the “P” port on the knob?	Yes	Repair or replace the knob.
	No	Reconnect the air line to the knob, and continue to the next step.

2. Test the regulator pressure. (Regulator pressure should be between 75 and 85 PSI (517-586 kPa).)

Reconnect the “P” line at the shift knob. Locate the two small pipe plugs on the rear of the air module. One is labeled “H” and the other “L”. (See Figure 4-1 “Air System Nomenclature”). Install a 0-150 PSI (0-1034 kPa) air gauge in the port marked “H.”

**Note:** Prior to removing the pipe plug, turn off the air flow by flipping the range selector down into the low range position. The transmission must be in neutral.

Move the range selector up to the high range position and record the pressure on the gauge. Match the pressure to one of those on the chart on the next page, and follow the corresponding instructions.

Question	Result	What to do Next
What is the air pressure at the “H” port?	75-85 PSI (517-586 kPa) (to specification)	Continue to the next step.

# Air System Troubleshooting

Question	Result	What to do Next
	Less than 75 PSI (517 kPa)	On the top of the air module, remove the test port pipe plug for filtered vehicle air. (Marked "F" as shown in Figure 4-1.) Install the test gauge in the "F" port, and check the pressure. If the pressure is less than 90 PSI (620 kPa), repair the vehicle air system to achieve full vehicle air pressure at the air module inlet, and repeat the test. If the pressures greater than 90 PSI (620 kPa) and no external air leaks were detected from the air module, shift knob, or transmission, replace the air module.
	Greater than 85 PSI (586 kPa)	Replace the air module.

### 3. Check the spool valve function.

With the shift lever in neutral, move the range selector from low to high several times. Answer the question on the chart below, and follow the instructions corresponding to the result.

Question	Result	What to do Next
Does the gauge rapidly go from 75-85 PSI (517-586 kPa) in High to 0 PSI in Low?	Yes	Air system performs properly. Go to step 5.
	No	Continue to the next step.

### 4. Isolate and test the air module. Refer to Figure 4-1 "Air System Nomenclature" to see an example of an isolated air module.



**WARNING:** Failure to exhaust the air module may cause personal injury or damage to parts due to the rapid release of air.

Exhaust the air pressure from the air module. To do so, the vehicle air tanks may need to be exhausted. Remove the four capscrews attaching the air module to the shift bar housing. Lift the air module and tilt it to gain access to the two air holes at the underside at the rear capscrew location. Do not damage or lose the two O-rings used to seal the holes. Block off the air ports on the underside of the module. Repressurize the air module with an inlet supply pressure of over 90 PSI (620 kPa). To repressurize the air module, the vehicle may need to be started and the air pressure allowed to build. With the shift lever in neutral and the gauge still in the "H" test port, move the range selection lever from high to low (down) position.

Answer the question on the chart below, and follow the instructions corresponding to the result.

Question	Result	What to do Next
Does the gauge rapidly go from 75-85 PSI (517-586 kPa) in High to 0 PSI in Low?	Yes	Continue to the next step.
	No	Replace the air module.

### 5. Install the air module, and remove the range alignment lock cover (Figure 4-3). Then move the range selection lever from the low to high (up) position. If range now shifts properly, inspect and correct the source of binding between lock cover and range yoke bar.

**Note:** To prevent binding, range alignment lock cover capscrews must be tightened when transmission is in Low Range. If the transmission does not shift properly, continue to Step 6.

# Air System Troubleshooting

---

- 6.** Remove the auxiliary section and inspect the range synchronizer, range yoke, range yoke bar, range yoke snap ring, range sliding clutch, and mating gears for excessive wear, binding, or damage. Repair as necessary. If these components do not need repair, continue to Step 7.
- 7.** Remove the shift bar housing and inspect the range piston, piston bar, and cylinder for excessive wear, binding, or damage. Repair as necessary.

# Air System Troubleshooting

## Air System Symptom - No or Slow Range Shift into Low (Shift into High is Good)

### Test Procedure:

1. Check the shift knob operation.

On the shift knob, remove the two screws holding the plastic skirt. Slide the skirt down and out of the way. Move the range selector up into high range. Disconnect the black line connected to the “P” port on the knob. Move the range selector down into low. Answer the question on the chart below and follow the instructions corresponding to the result.

Question	Result	What to do Next
Does air come out of the “P” port on the knob?	Yes	Go to Step 3.
	No	Reconnect the air line to the knob, and continue to the next step.

2. Check the air supply to the shift knob.

Disconnect the red line from the “S” port on the shift knob. Answer the question on the chart below and follow the instructions corresponding to the result.

Question	Result	What to do Next
Is air coming out of the red line?	Yes	Repair or replace the shift knob.
	No	Loosen the air fitting for the line that supplies vehicle air to the module inlet. If no air is available here, repair the vehicle air to the air module. If air is available at the inlet, check the red line going from the air module to the shift knob for obstructions or damage. If the line is clear, replace the air module.

3. Check the black line for obstruction.

Reconnect the black line at the shift knob. At the air module, disconnect the black air line from the “P” port. Answer the question on the chart below and follow the instructions corresponding to the result.

Question	Result	What to do Next
Is air available on the line when the range selector is in the Low position?	Yes	Continue to next step.
	No	Repair the black line for damage or obstruction.

4. Check the regulator pressure.

Reconnect the “P” line at the air module. Locate the two small pipe plugs on the rear of the air module. One is labeled “H,” and the other is labeled “L”. (See Figure 4-1 “Air System Nomenclature”). Install a 0-150 PSI (0-1034 kPa) air gauge in the port marked “L”.

**Note:** Prior to removing the pipe plug, turn off the air flow by placing the range selector up into the high range position. The transmission must be in neutral.

# Air System Troubleshooting

Move the range selector down to the low position and record the pressure on the gauge. Match the air pressure to one of those described on the chart on the next page, and follow the corresponding instructions.

Question	Result	What to do Next
What is the air pressure at the “L” port?	75-85 PSI (517-586 kPa) (To specification.)	Continue to the next step.
	Less than 75 PSI (517 kPa)	On the top of the air module, remove the test port pipe plug for filtered vehicle air. (Marked “F” as shown in Figure 4-1 “Air System Nomenclature”) Install the test gauge in the “F” port, and check the pressure. If the pressure is less than 90 PSI (620 kPa), repair the vehicle air system to achieve full vehicle air pressure at the module inlet, and repeat the test. If the pressure is greater than 90 PSI (620kPa) and no external air leaks were detected from the air module, shift knob, or transmission, replace the air module.
	Greater than 85 PSI (586 kPa)	Replace the air module.

## 5. Check the spool valve function.

With the shift lever in neutral, move the range selector from low to high several times. Answer the question on the chart below and follow the instructions corresponding to the result.

Question	Result	What to do Next
Does the gauge rapidly go from 75-85PSI (517-586 kPa) in Low to 0 PSI in High?	Yes	Air system performs properly. Go to step 7.
	No	Continue to the next step.

## 6. Isolate the air module from the transmission. Refer to Figure 4-4 “Air System Nomenclature” to see an example of an isolated air module.



**WARNING:** Failure to exhaust the air module may cause personal injury or damage to parts due to the rapid release of air.

Exhaust the air pressure from the air module. To do so, you may have to exhaust the vehicle air. Remove the four capscrews attaching the air module to the shift bar housing. Lift the air module and tilt it to gain access to the two air holes on the underside at the rear capscrew location. Do not lose or damage the two small O-rings that seal the holes. Block off the air ports at the underside of the module. Repressurize the air module with an inlet supply pressure of over 90 PSI (620 kPa). To repressurize the air module, the vehicle may have to be started and the air pressure allowed to build. With the shift lever in neutral and the gauge still in the “L” test port, move the range selector from low to high (up) position.

Answer the question on the chart below, and follow the corresponding instructions.

Question	Result	What to do Next
Does the gauge rapidly go from 75-85PSI (517-586 kPa) in Low to 0 PSI in High?	Yes	Continue to next step.



# Air System Troubleshooting

---

Question	Result	What to do Next
	No	Replace the air module.

7. Install the air module, and remove range alignment lock cover (Figure 4-3 “Air System Nomenclature”). Then move the range selector from low to high (up) position. If range now shifts properly, inspect and correct the source of binding between lock cover and range yoke bar.

**Note:** To prevent binding, range alignment lock cover capscrew must be tightened when transmission is in Low Range. If transmission does not shift properly, continue to Step 8

8. Remove the auxiliary section, and inspect range synchronizer, range yoke, range yoke bar, range yoke snap rings, range sliding clutch, and mating gears for excessive wear, binding, or damage. Repair as necessary. If these components do not need repair, continue to step 9.

9. Remove shift bar housing and inspect range piston, piston bar, and cylinder for excessive wear, binding, or damage. Repair as necessary.

## **Air System Symptom - Constant Air Leak from Shift Knob**

In normal operation, a burst of air will be exhausted from the shift knob when moving the range selector from low to high range.

If a constant air leak is detected, first check for a leaking fitting. If the leak occurs when both high and low range are selected and the leak is from the exhaust "E" port on the shift knob. Repair or replace the shift knob.

If the leak only occurs in high range, check for reversed hook up of "P" and "S" air lines. If the air lines are connected properly, repair or replace the shift knob.

# Air System Troubleshooting

---

## Air System Symptom - Range Shift While Transmission is in Gear

The interlock mechanism allows the driver to move the range selection lever while still in gear (preselect). The range will then shift when the shift lever moves into neutral. If the driver preselects a range shift and the shift occurs while the shift lever is in gear, a problem is present.

### Test Procedure:



**WARNING:** Failure to exhaust the air module may cause personal injury or damage to parts due to the rapid release of air.

1. Exhaust air pressure from the air module. To do so, the vehicle air may need to be exhausted.
2. Remove the four capscrews attaching the air module to the shift bar housing. Lift the air module and tilt it to gain access to the module interlock finger. Do not lose or damage the two O-rings at the rear mounting capscrew.
3. Inspect the module interlock finger for excessive wear. Replace, if necessary.
4. Shine a bright light into the hole the interlock finger engages. Inspect the chamfer on the shift shaft for excessive wear. To inspect the chamfer, the transmission may need to be shifted into gear so both the forward and rearward chamfers are visible. If the chamfer is excessively worn, remove the shift bar housing, disassemble, and replace the worn parts.
5. If the shift shaft is not excessively worn, replace the air module.

## Air System Symptom - Air Leak From Breather or Case is Pressurized

If the air leak occurs when the transmission is in high range, the problem is with the range cylinder in the transmission. Remove the shift bar housing, and disassemble and inspect the range cylinder for worn or missing o-rings. Also, inspect the shift bar housing for cracks or porosity.

If the leak only occurs when the transmission is shifted to low range, the air module may be leaking into the transmission at the interlock finger location. Prior to removing the shift bar housing, perform the following test to determine the problem.

### Test Procedure:



**WARNING:** Failure to exhaust the air module may cause personal injury or damage to parts due to the rapid release of air.

Exhaust the air pressure from the air module. To do so, the vehicle air may need to be exhausted. Remove the four capscrews attaching the air module to the shift bar housing. Lift the air module and tilt it to gain access to the two air holes at the underside at the rear capscrew location. Do not lose or damage the two small o-rings near the rear capscrew location. Block off the air ports on the underside of the module (Figure 4-4 “Air System Nomenclature”). Repressurize the air module with an inlet supply pressure of over 90 PSI (620 kPa). Repressurizing the air module may require starting the vehicle and allowing the air pressure to build. Shift the transmission into low range. Answer the question on the chart below, and follow the instructions corresponding to the result.

Question	Result	What to do Next
Can any air leakage be detected at the module interlock finger?	Yes	Replace the air module.
	No	Air leak is at the range cylinder. Remove the shift bar housing, and disassemble and inspect the range cylinder for worn or missing o-rings. Also inspect the shift bar housing for cracks or porosity.

# Operation

---

## Air Line Color Chart

Eaton® Fuller® 5/32" air lines are color coded for easy identification. Use the follow chart along with the appropriate system schematic when troubleshooting and repairing your air system.

Nomenclature	Color
S- Supply	Red
P-Pilot	Black
H/L- Splitter or Deep reduction	Green
A- Supply, Non-regulated	Orange
SP- Splitter pilot	Blue
B- Brake signal	Yellow
E-Exhaust	Brown

## Slave Valve Preselection System

An air valve shaft protruding from the shift bar housing prevents the actuating piston in the slave valve from moving while the gear shift lever is in a gear position and releases the piston when the lever is moved to or through neutral.

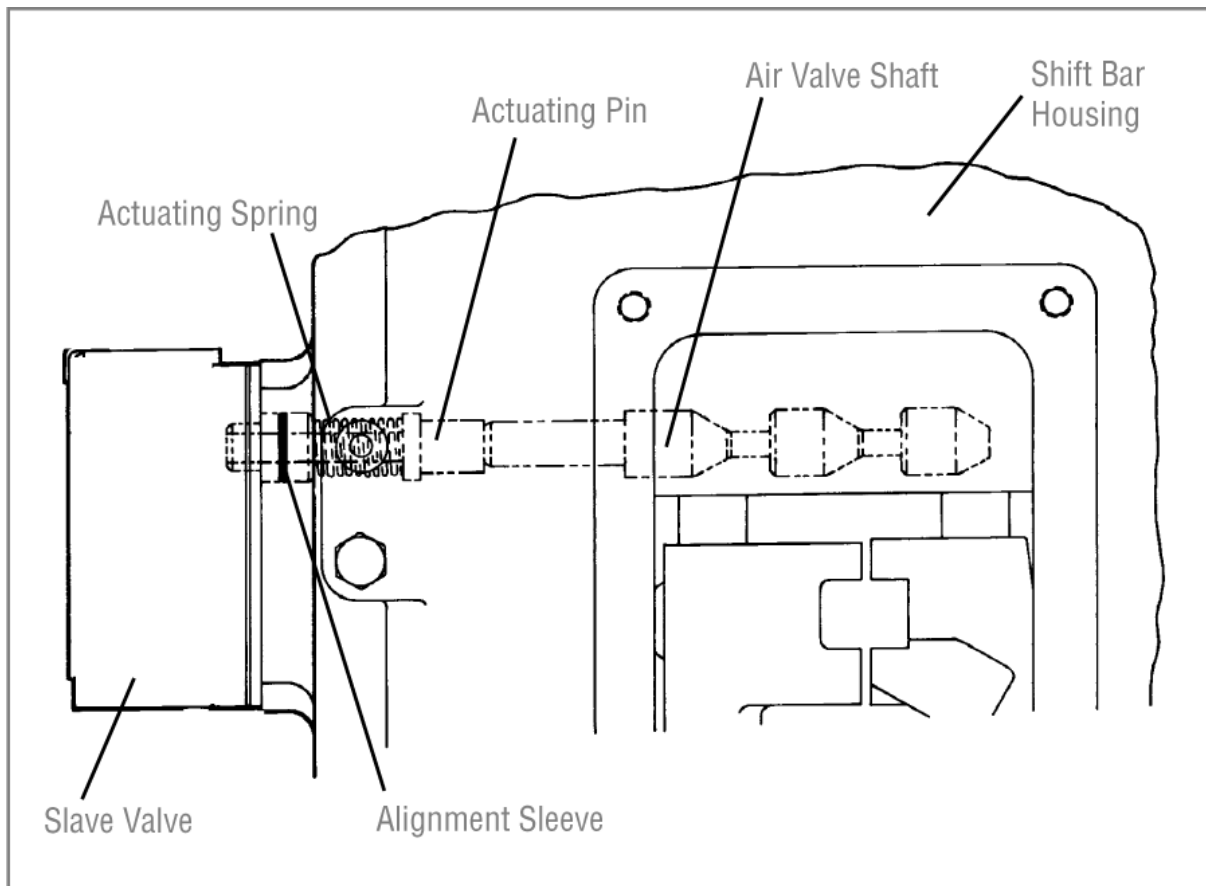

Operation

# Operation

## 7, 8, 9 and 10-Speed Range Air Systems

Air is supplied to the system at the air supply port (1) by the vehicle's air system. The air filter (2) removes foreign matter from the air then allows it to pass through the air regulator (3) where the pressure is adjusted for 58 to 63 PSI (4.0 daN/cm<sup>2</sup>). From there the air passes through the supply air hose (4) and the slave valve supply port (5) through the supply air line (6) to the range control valve (7). With the range control valve lever or knob down (LO range), air passes through the air line connected to the slave valve "P" port (8). The slave valve then directs air to the LO range hose (9) and exhausts the HI range hose (10). With the range control valve lever or knob up (HI range,) the air line connected to the slave valve "P" port (8) is exhausted. The slave valve then directs air to the HI range hose (10) and exhausts the LO range hose (9).

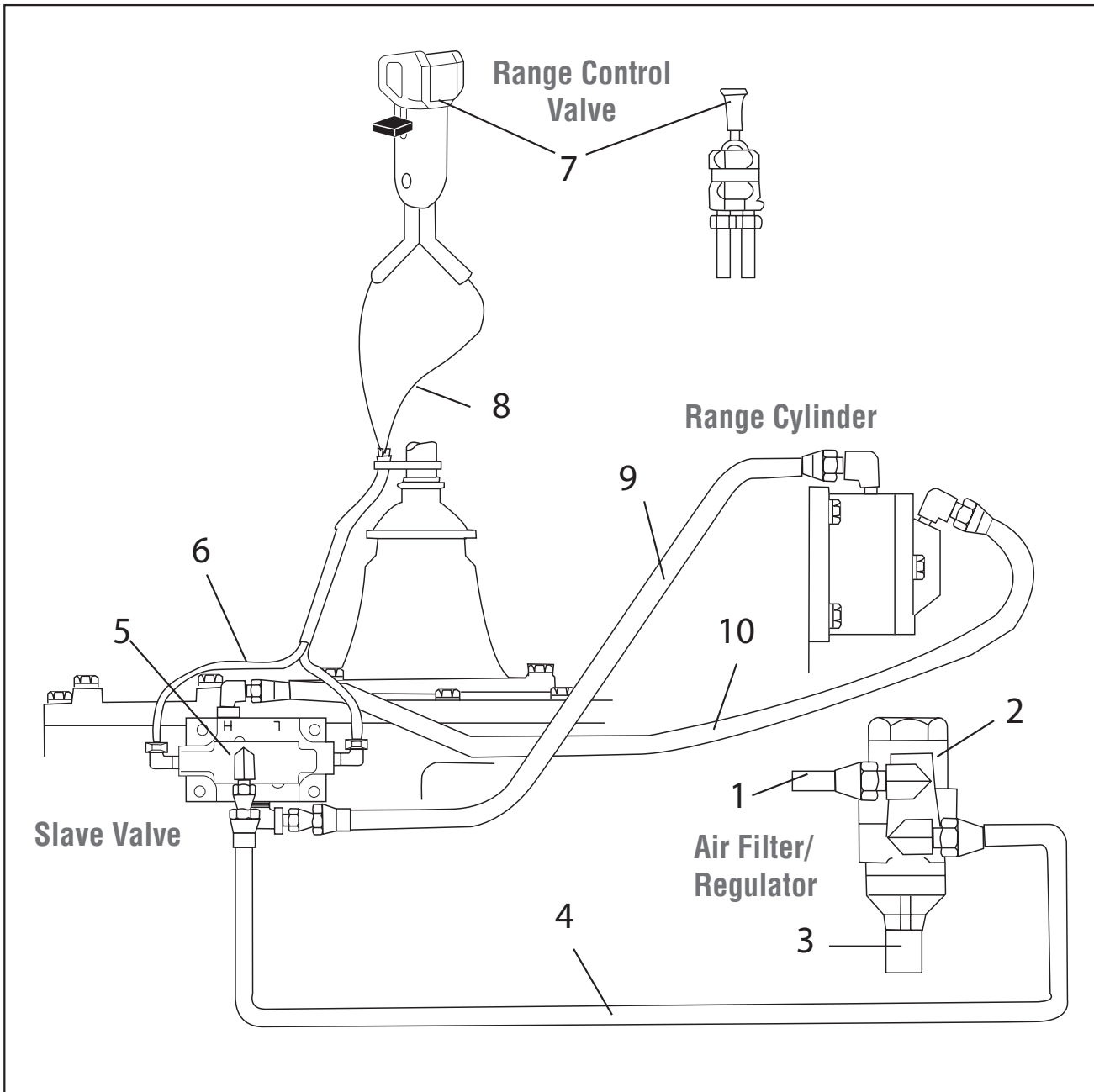

## 7L, 8, 9 and 10-Speed (2-Speed Auxiliary)

Range—LO

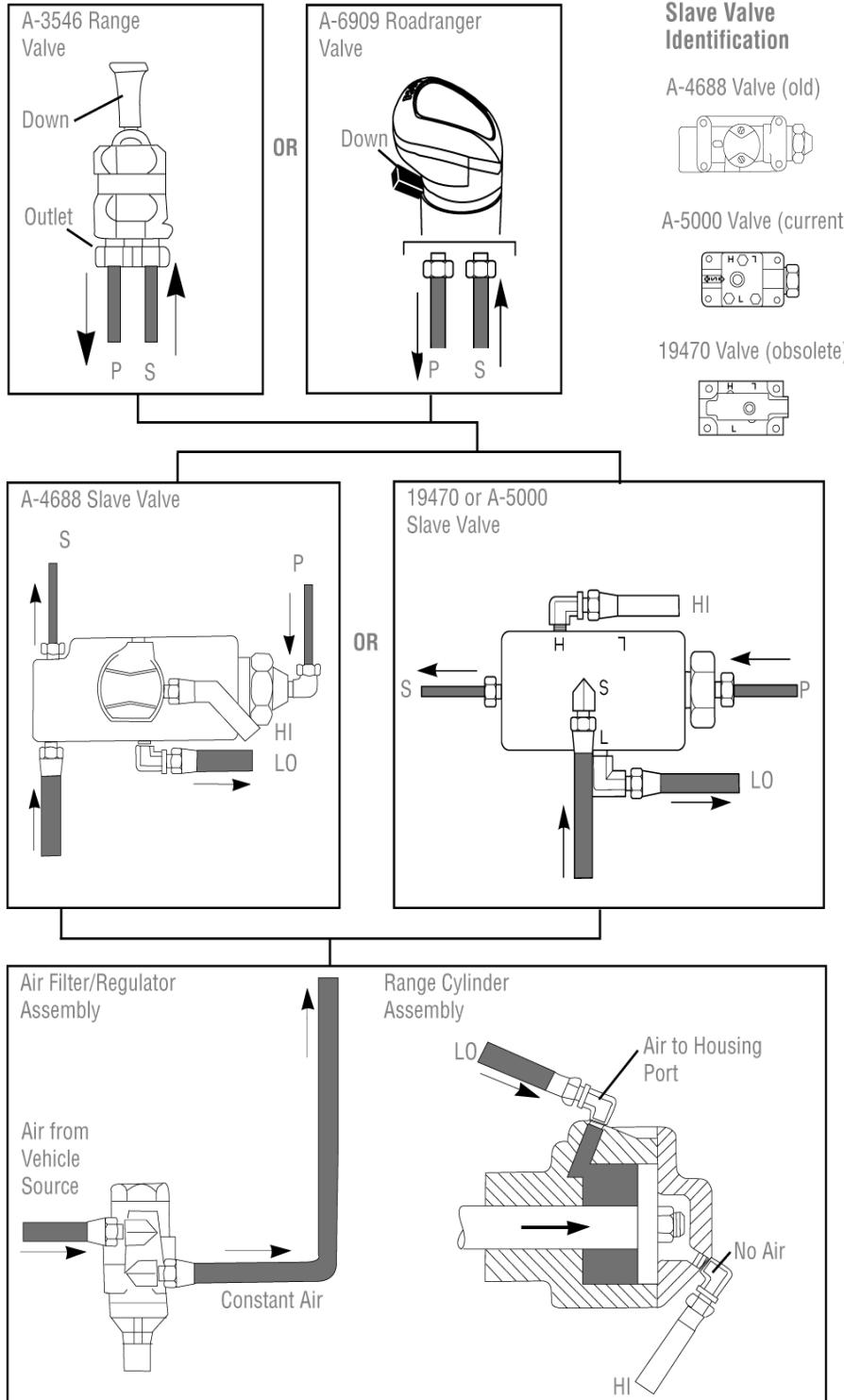

Operation



# Operation

Range—HI

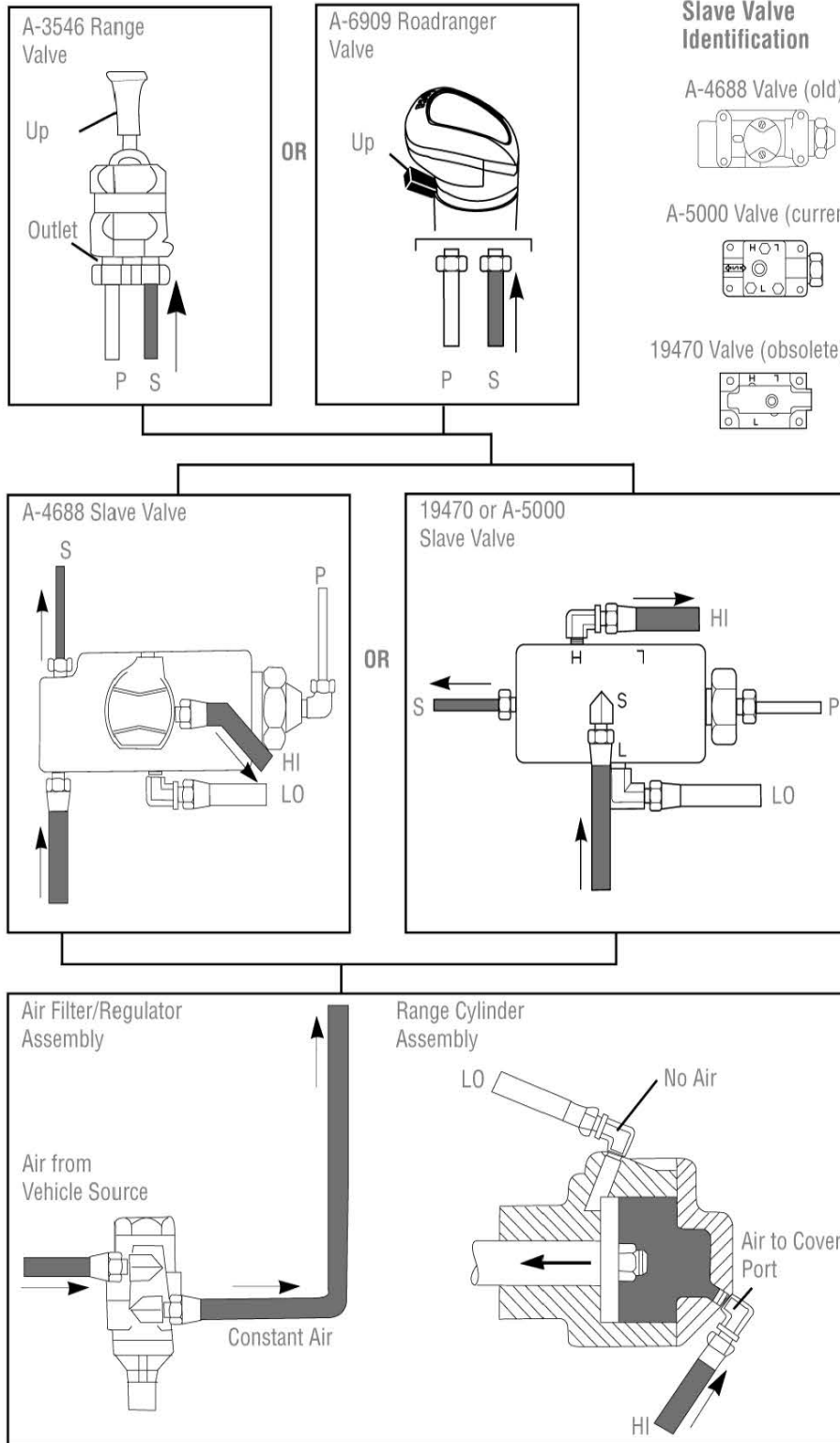

## RT & RTO-610, 6610, 6609, and 8609 Models

Range—LO

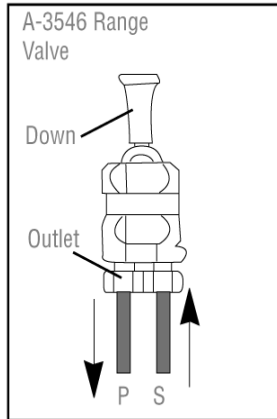

OR

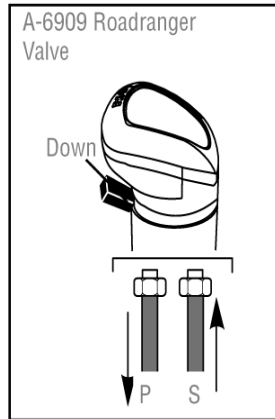

### Slave Valve Identification

A-4688 Valve (old)

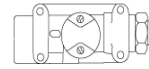

A-5000 Valve (current)

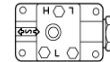

19470 Valve (obsolete)

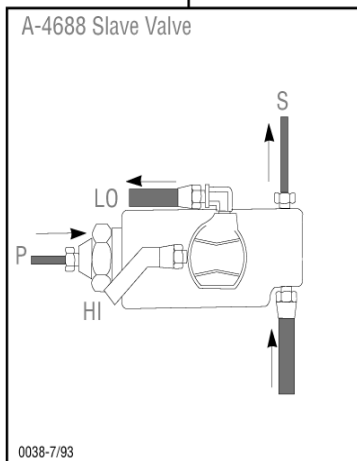
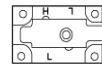

OR

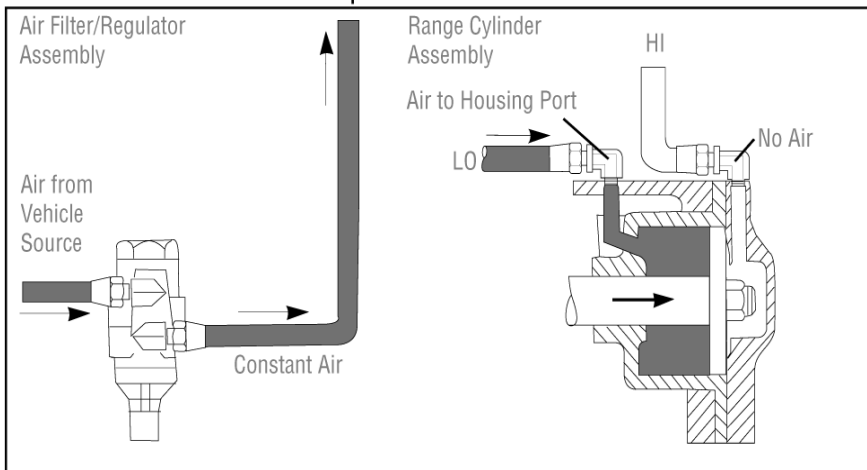
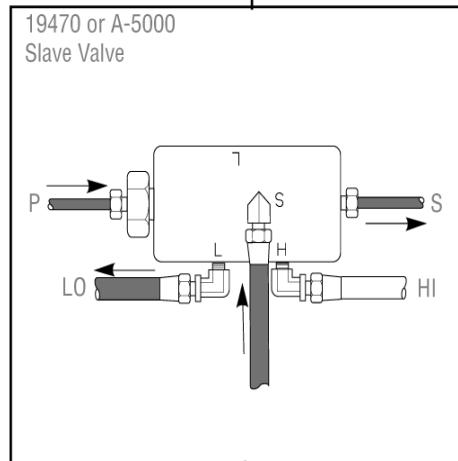

Operation

# Operation

Range—HI

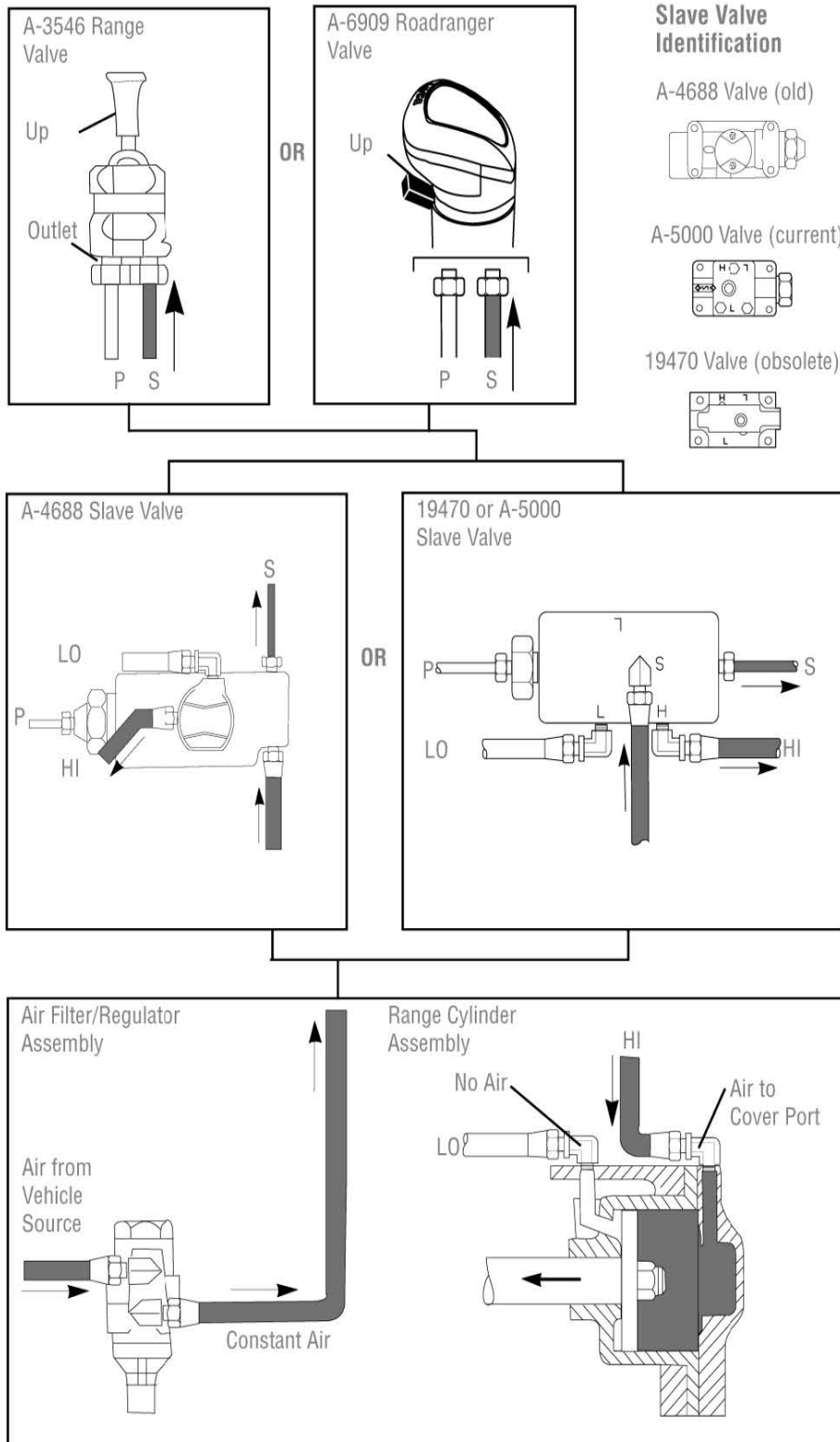

## Deep Reduction Air System (with Dash Mounted Valve)

In addition to the components of the range air system, the deep reduction air system utilizes a reduction cylinder and a separate dash mounted deep reduction valve. Air is supplied to the system at the air supply port (1) by the vehicle's air system. The air filter (2) removes foreign matter from the air then allows it to pass through the air regulator (3) where the pressure is adjusted for 58 to 63 PSI. From there the air passes through the supply air hose (4) to the slave valve supply port (5) through the supply air hose (6) to the deep reduction valve (7). Depending upon the position of the deep reduction valve lever, if air passes through the air hose (8) connected to the reduction cylinder center port (9) then the deep reduction gearing is disengaged. If there is no air, the constant air from the air filter/regulator assembly (10) moves the reduction piston rearward to engage deep reduction gearing.

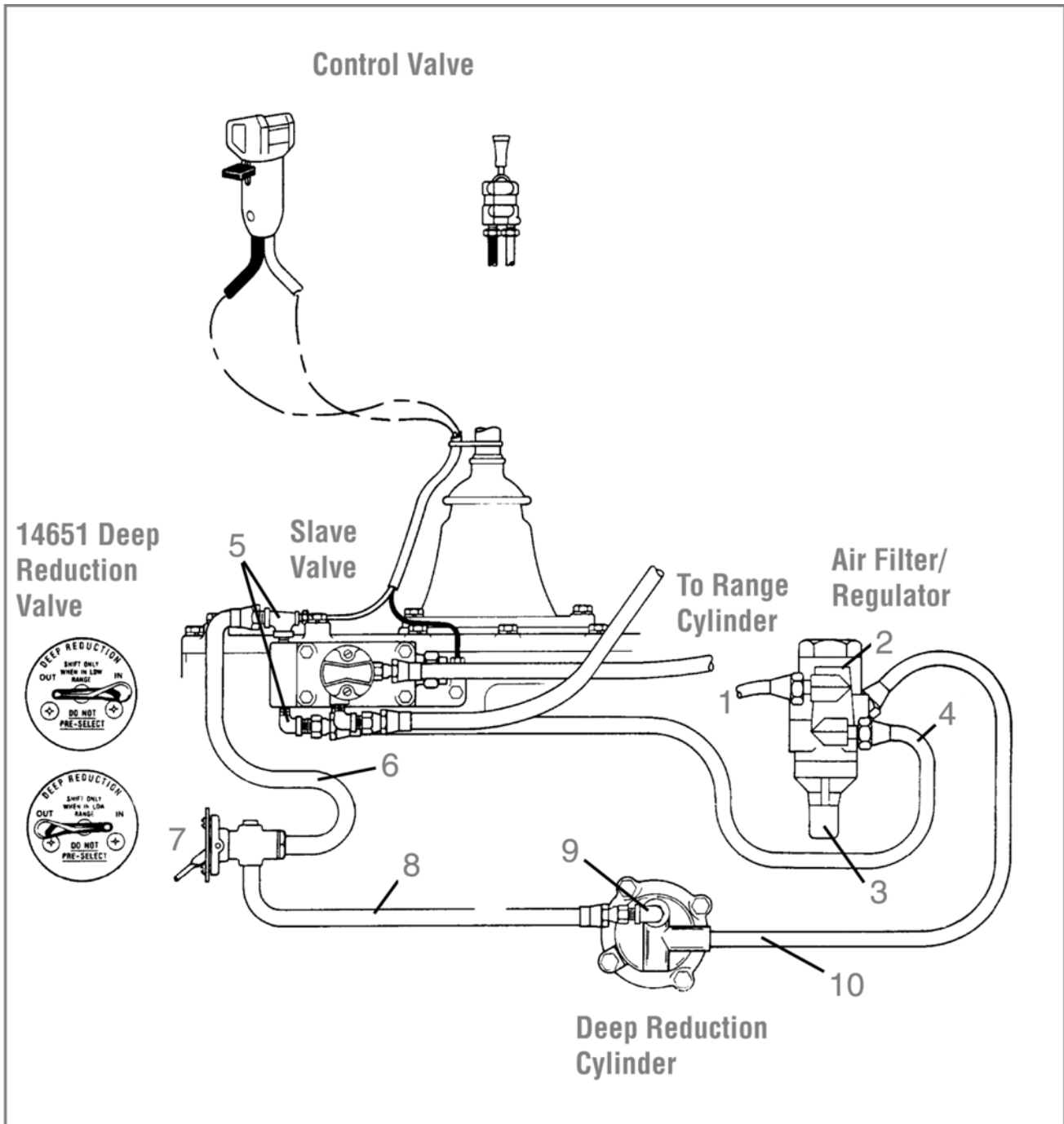

Operation



## Range—LO

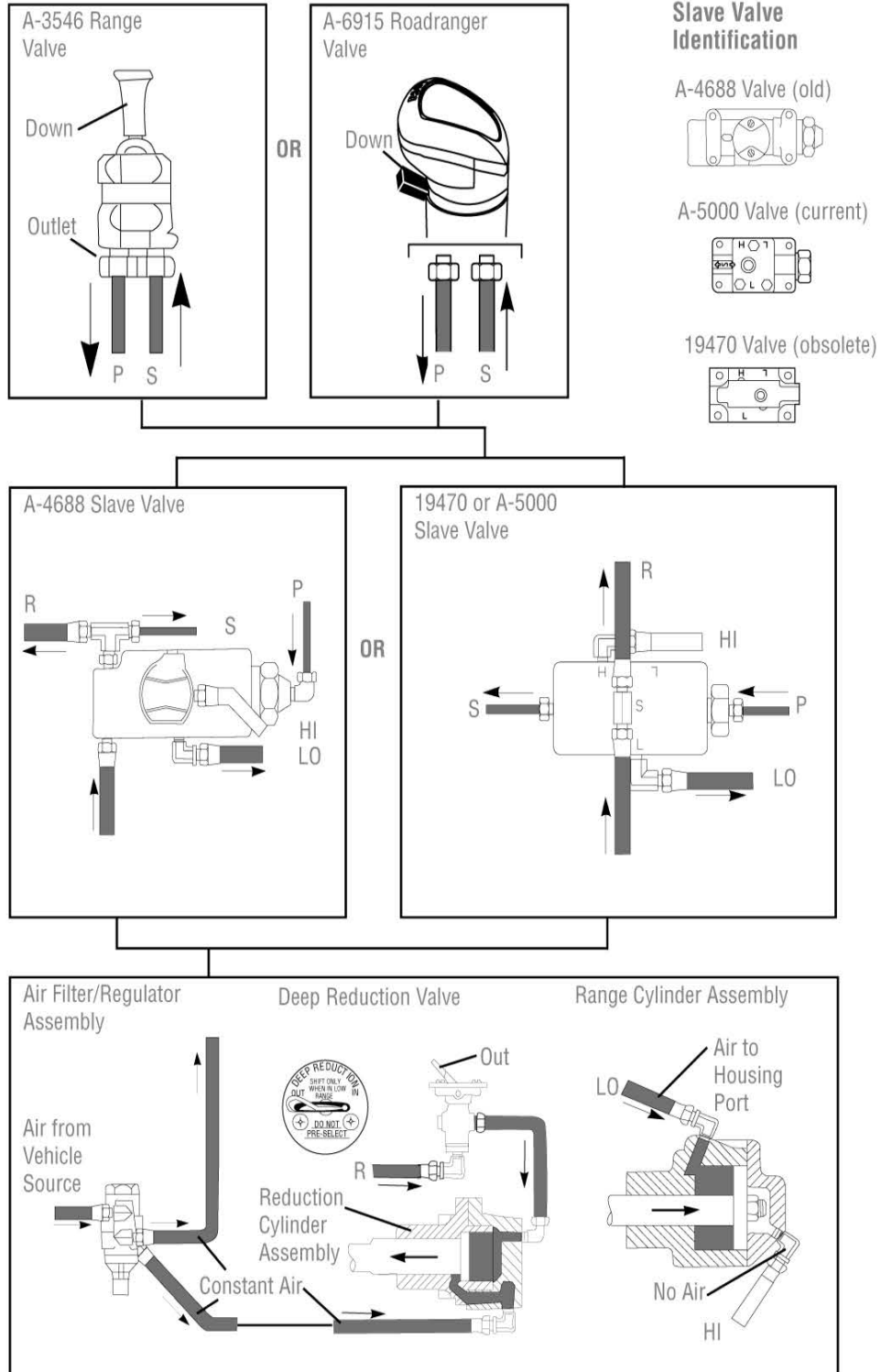

# Operation

## Range—HI

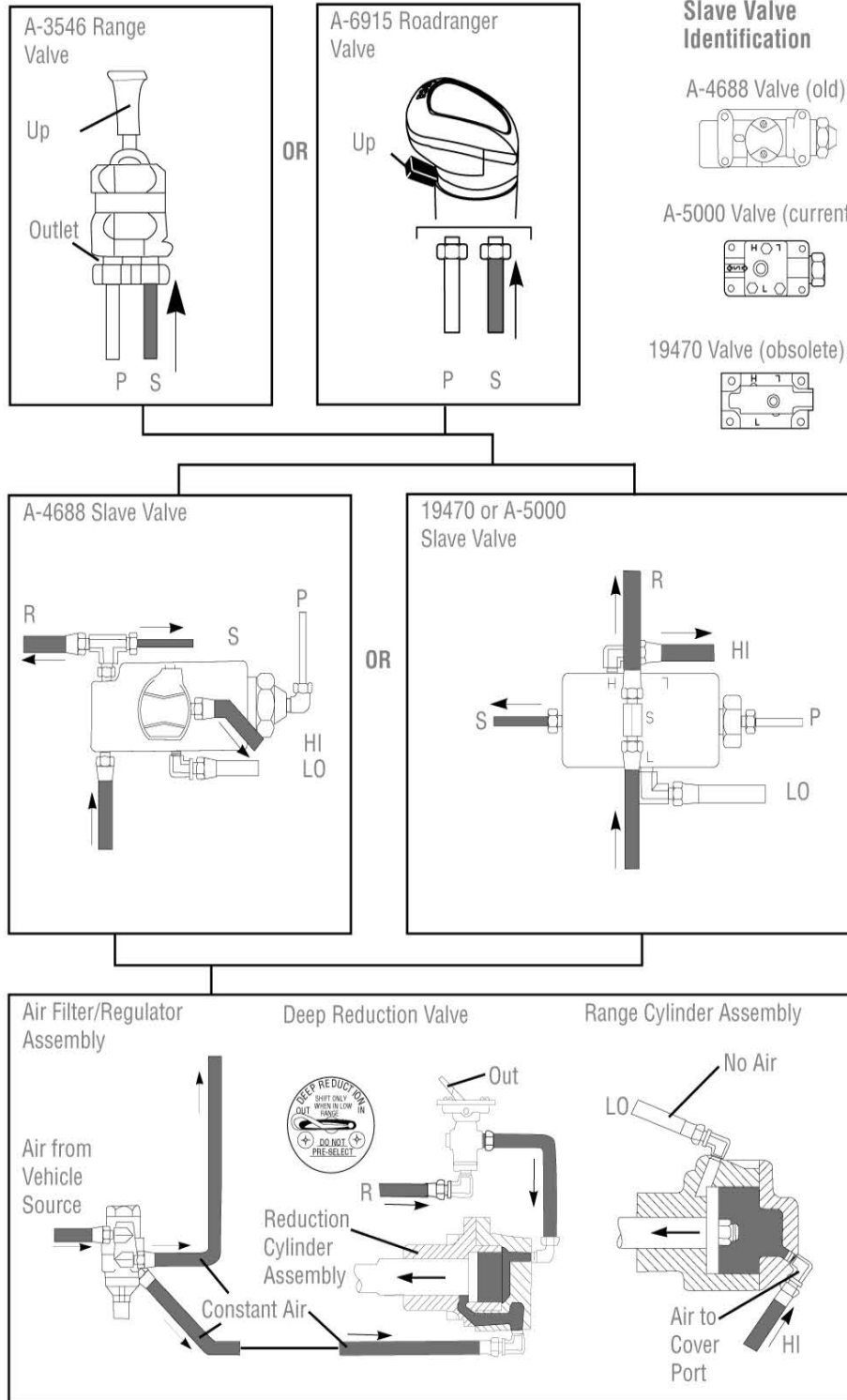

## Deep Reduction Air System (with A-6915 Roadranger Valve)

In addition to the range air system components, the deep reduction air system uses a reduction cylinder and the Roadranger Valve A-6915.

When the A-6915 Roadranger Valve is used, the deep reduction cover must be equipped with an insert valve.

Air is supplied to the system at the air supply port (1) by the vehicle's air system. The air filter (2) removes foreign matter from the air and allows it to pass through the air regulator (3) where the pressure is adjusted for 58 to 63 PSI. From there, the air passes through the supply air hose (4) to the slave valve supply port (5) through the supply air line to the Roadranger valve (6).

Depending upon the position of the Roadranger valve button (7), if air passes through the air line (8) connected to the reduction cylinder center port (9), then the deep reduction gearing is engaged. If there is no air, the constant air from the air filter/regulator assembly (10) moves the reduction piston rearward to disengage deep reduction gearing.

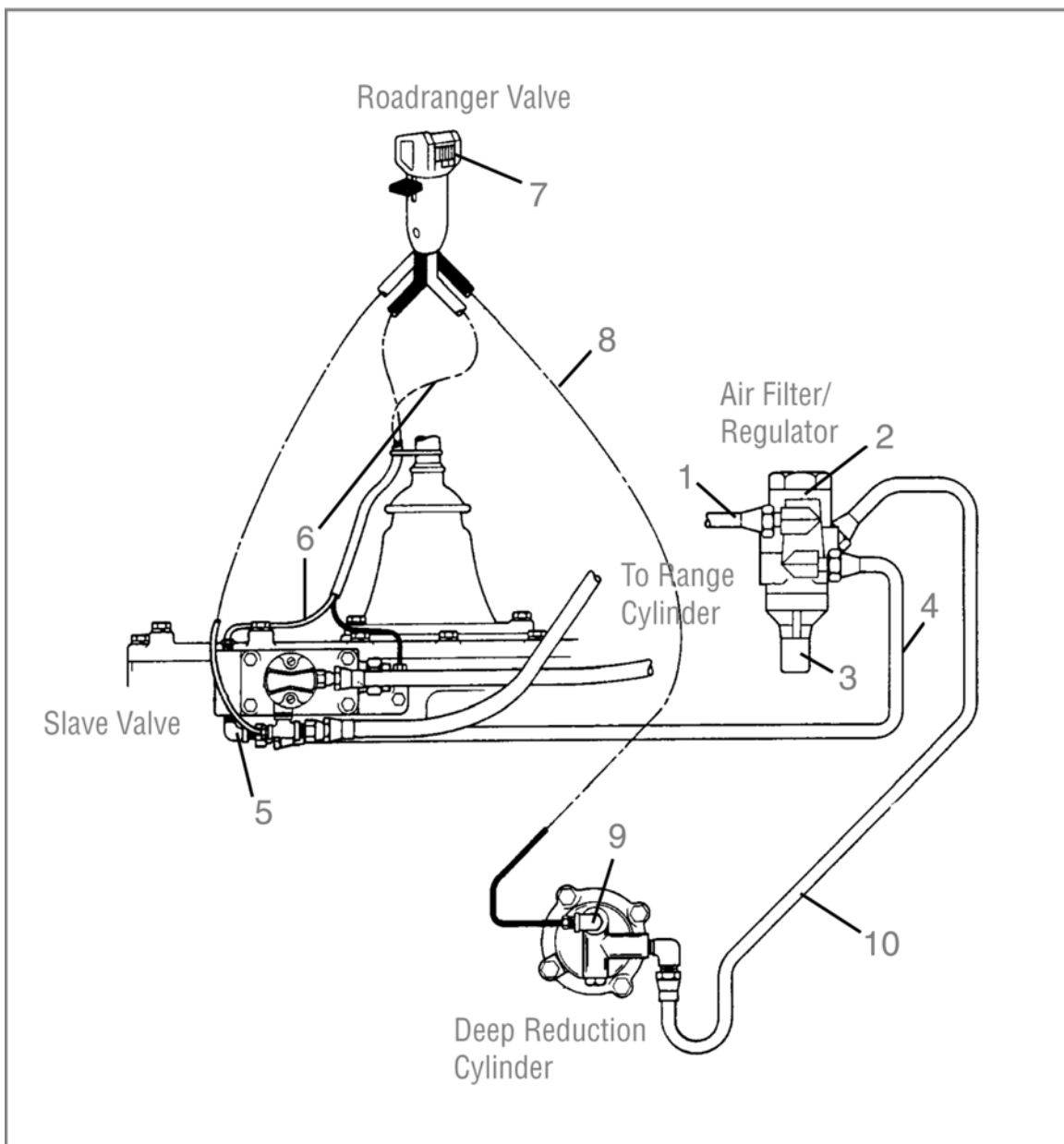

Operation



# Operation

## RT, RTO, & RTX xx607LL, xx608LL, and xx615 Models

### Deep Reduction

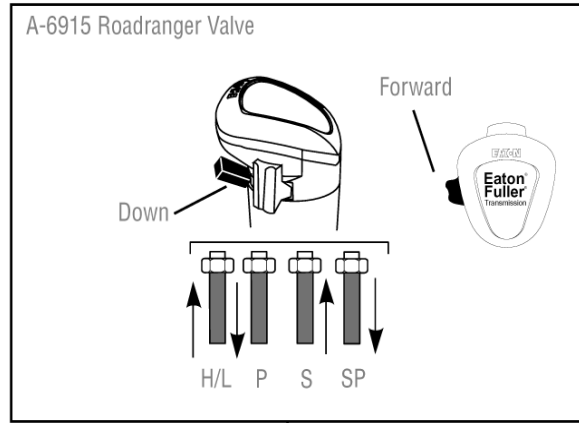

### Slave Valve Identification

A-4688 Valve (old)

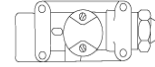

A-5000 Valve (current)

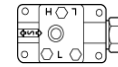

19470 Valve (obsolete)

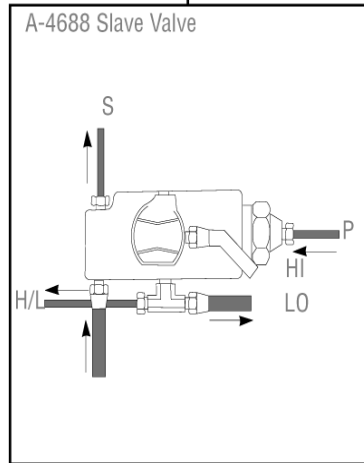
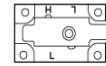

OR

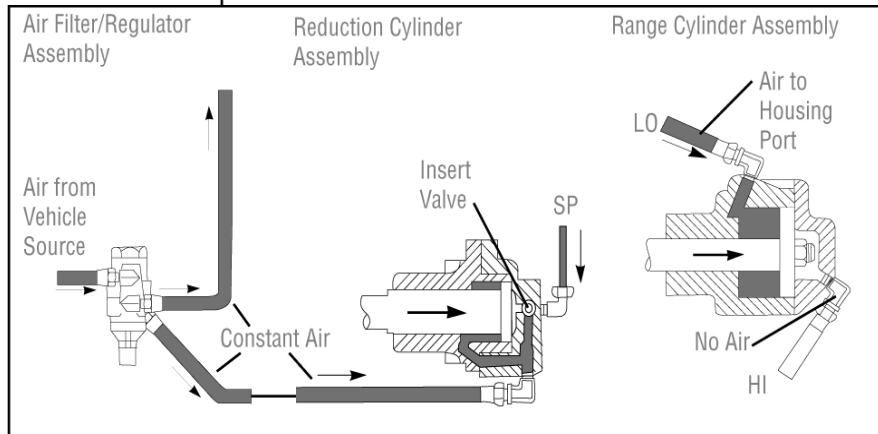
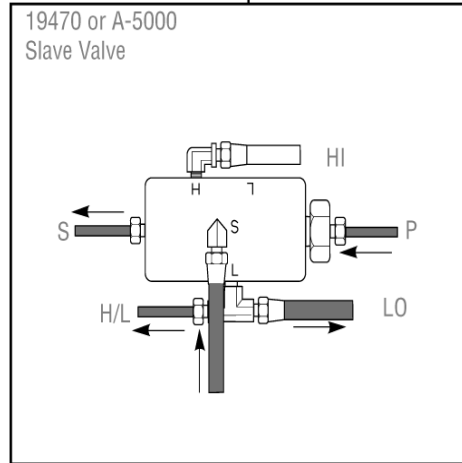

## Range—LO

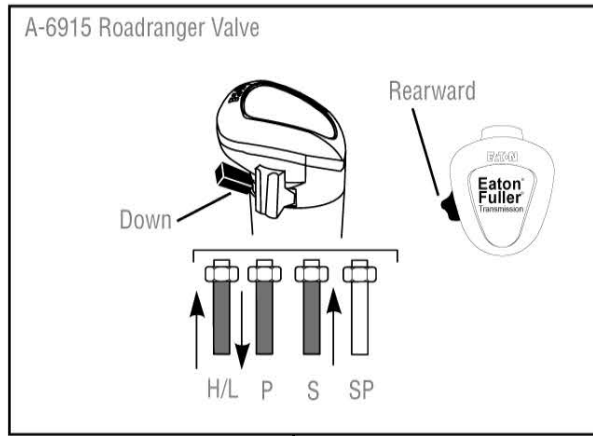

### Slave Valve Identification

A-4688 Valve (old)

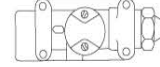

A-5000 Valve (current)

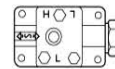

19470 Valve (obsolete)

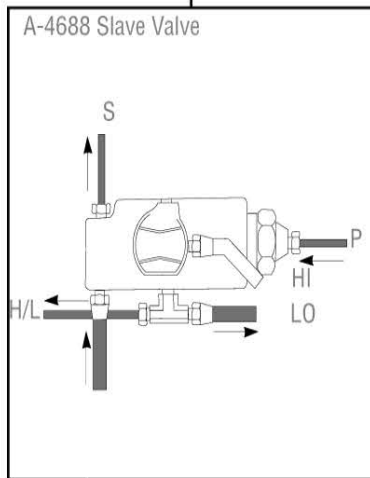
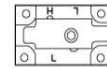

OR

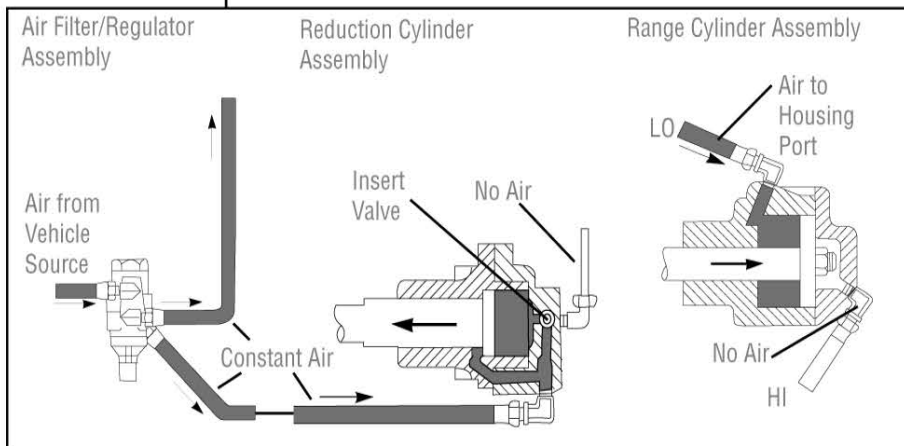
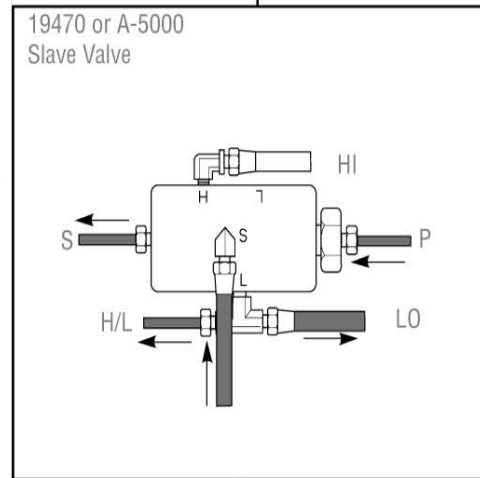

Operation

# Operation

Range—HI

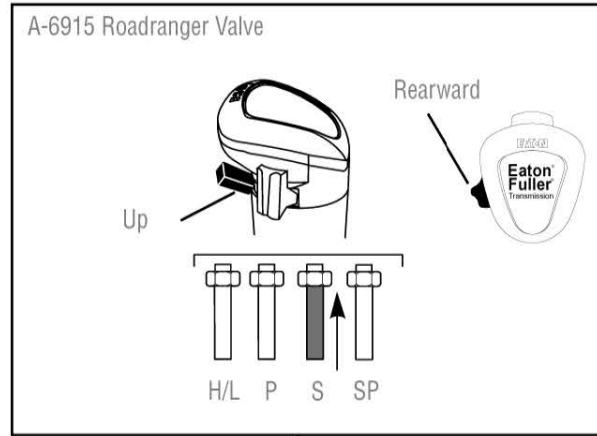

## Slave Valve Identification

A-4688 Valve (old)

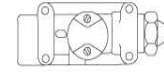

A-5000 Valve (current)

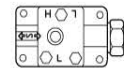

19470 Valve (obsolete)

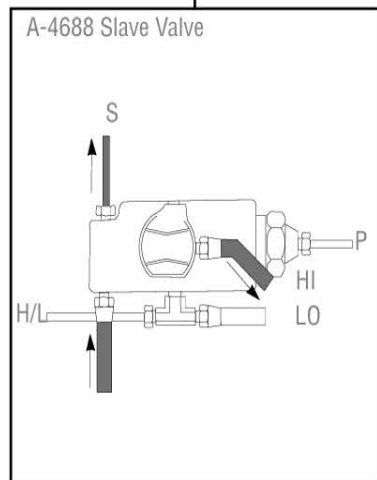
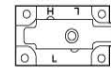

OR

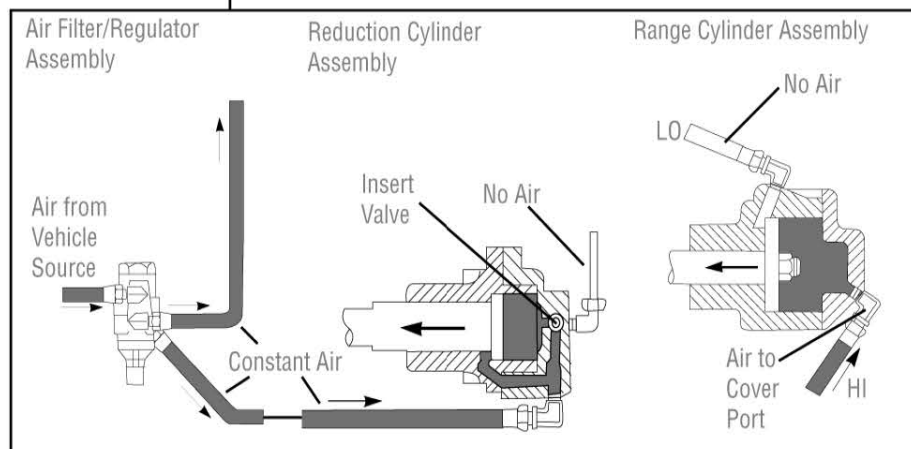
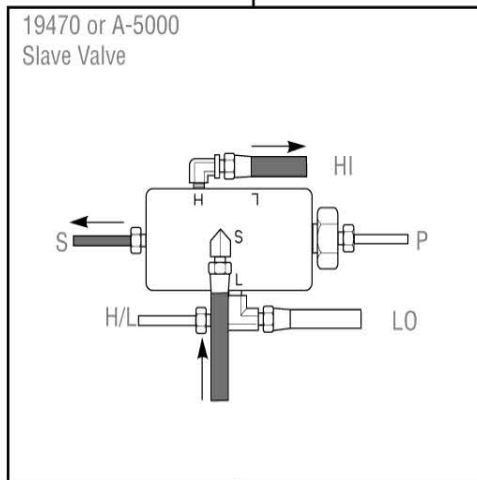

## 9 and 13-Speed Air Systems (Top 2 & Convertible) and 18-Speed (Top-2)

In addition to the range air system components, the splitter air system uses a splitter cylinder and the Roadranger Valve A-4900/ A-6913 or the Two-Position Selector Valve.

Air is supplied to the system at the air supply port (1) by the vehicle's air system. The air filter (2) removes foreign matter from the air then allows it to pass through the air filter regulator (3) where the pressure is adjusted for 58 to 63 psi. From there, the air passes through the supply air hose (4) to the slave valve supply port (5), through the supply air line (6) to the control valve.

Depending upon the position of the splitter button (7), if air passes through the air line (8) connected to the splitter cylinder center port (9) then the underdrive/overdrive gearing is engaged. If there is no air, the constant air from the air filter/regulator assembly (10) moves the splitter piston forward to disengage underdrive or overdrive gear.

### 18-Speed

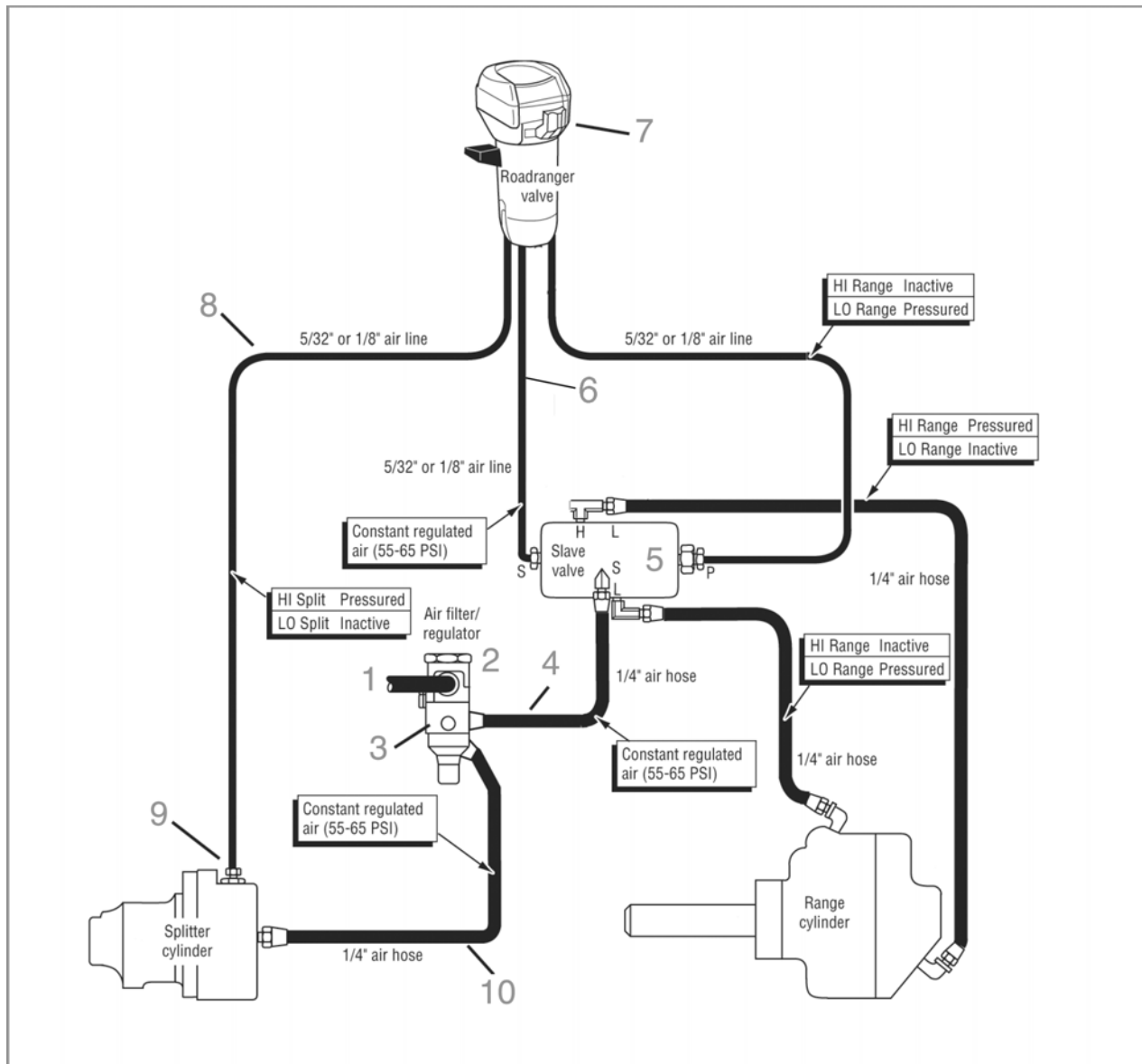

Operation

# Operation

## 13-Speed

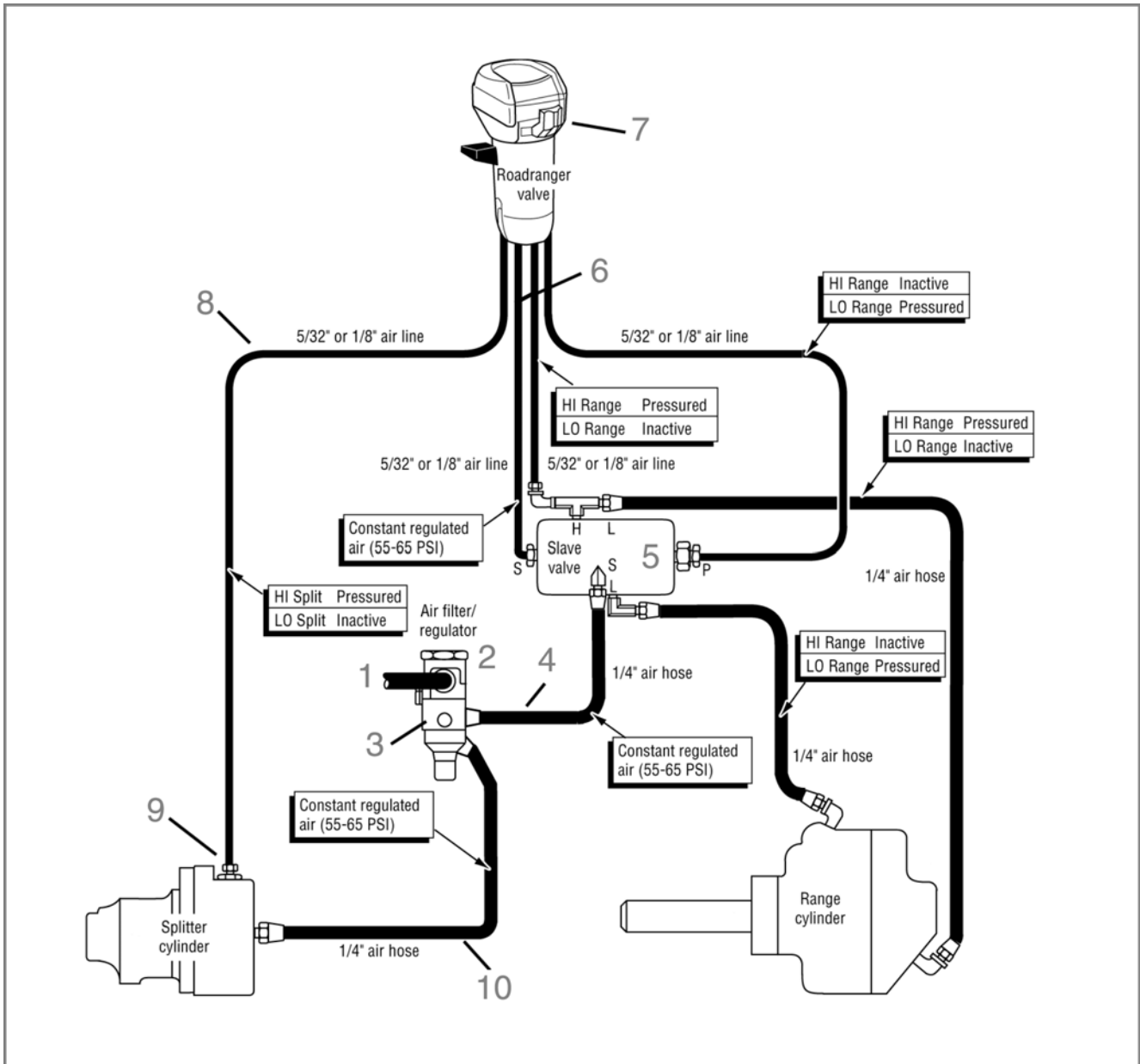

9-Speed Top 2 Convertible

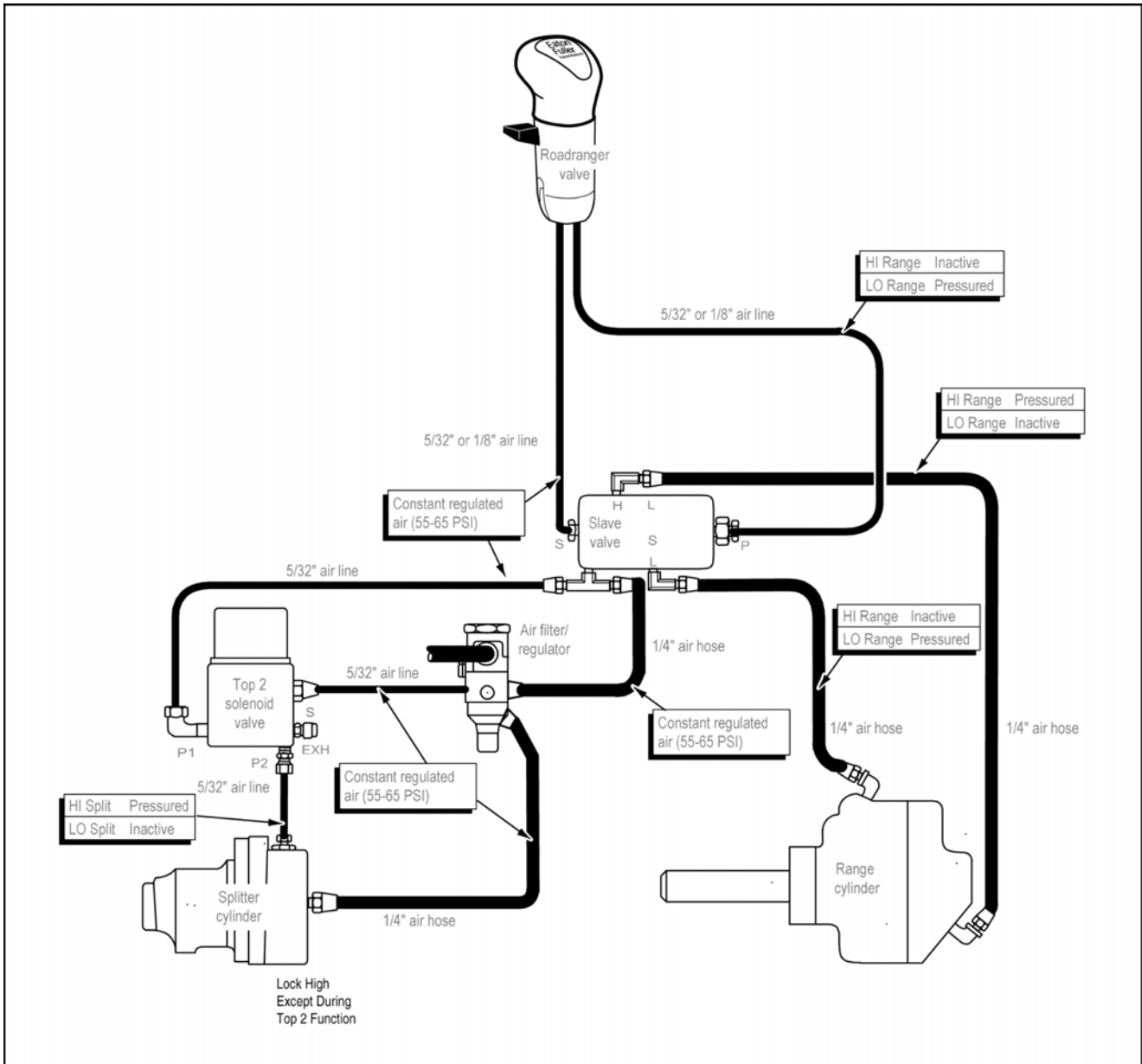

Operation

# Operation

## 9-Speed Non-Top 2 Convertible

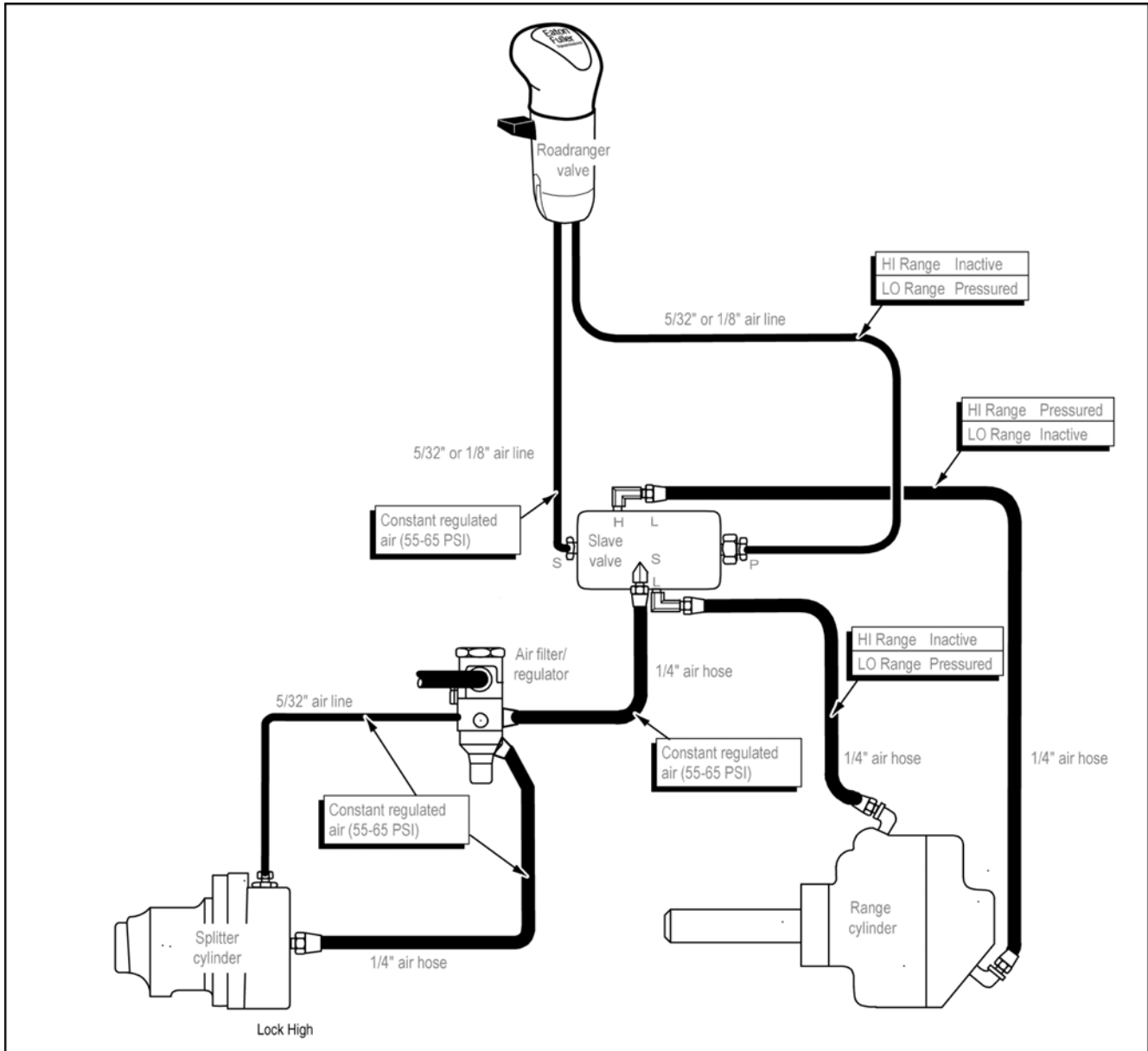

## RT, RTO, & RT00 xx613 and xx813 Models

Range—LO

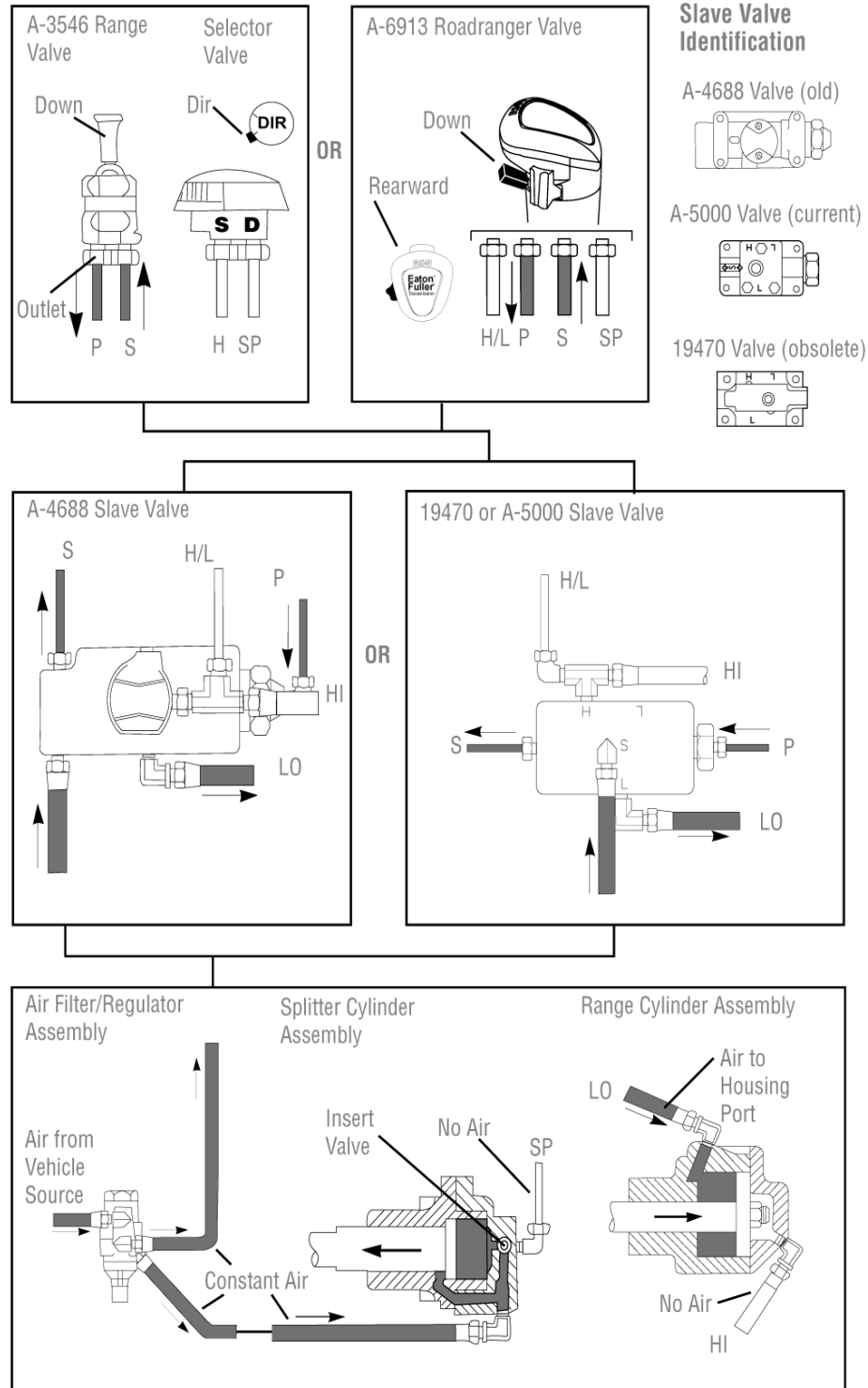

Operation



# Operation

## Range—HI/Splitter—Direct

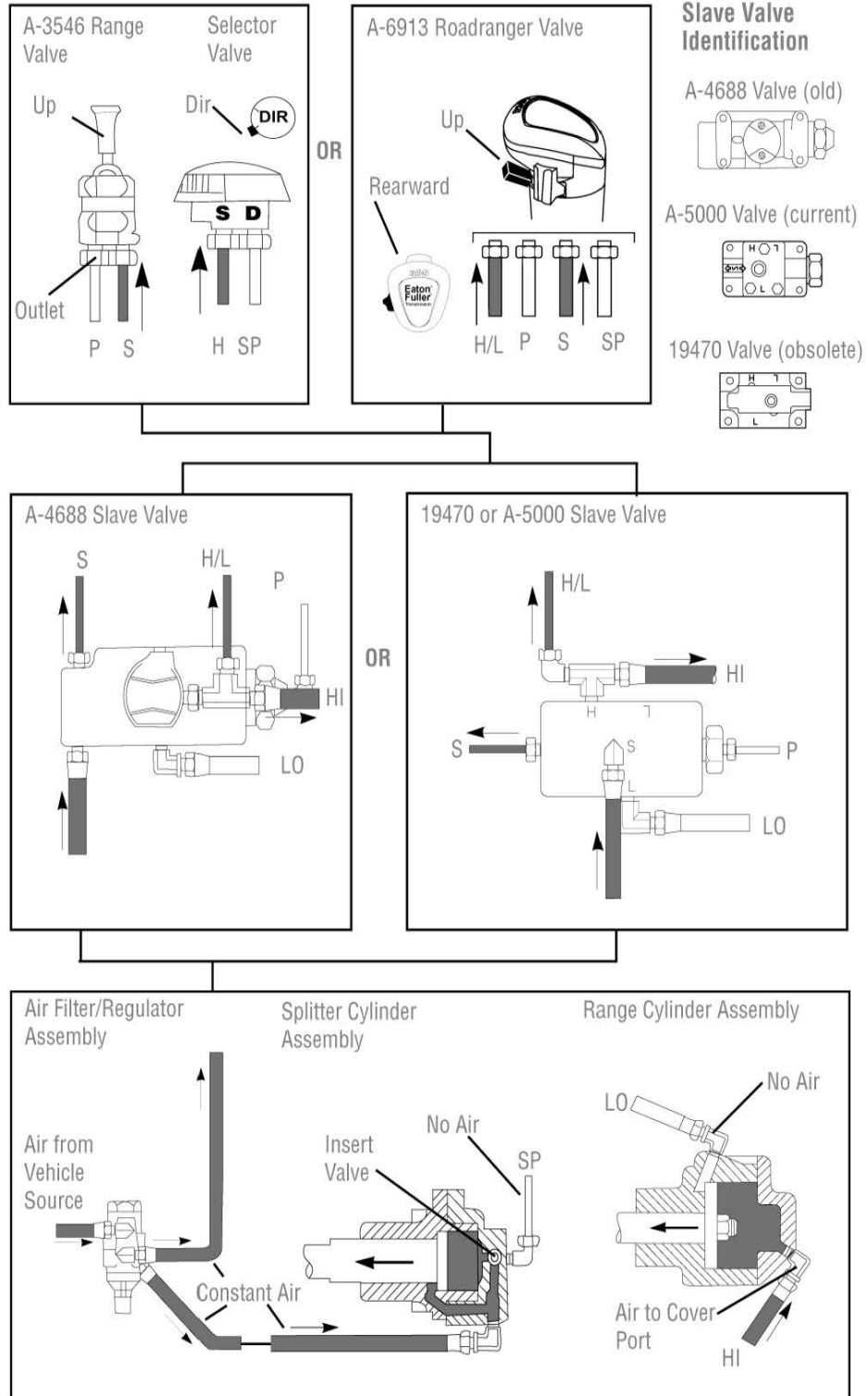

## Range—HI/Splitter—Underdrive or Overdrive

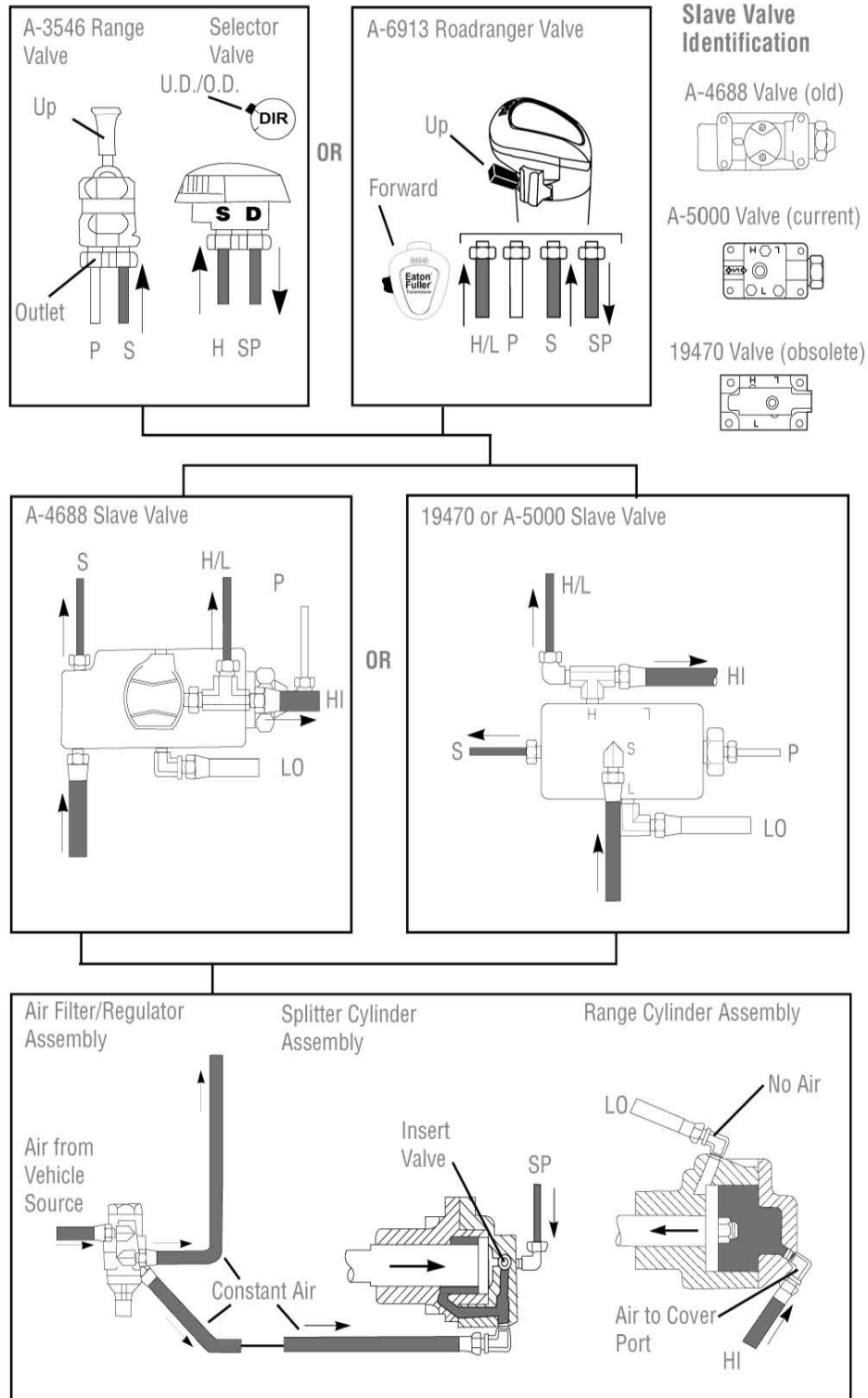

Operation

# Operation

## RTLO-xx613 Models

LO Range

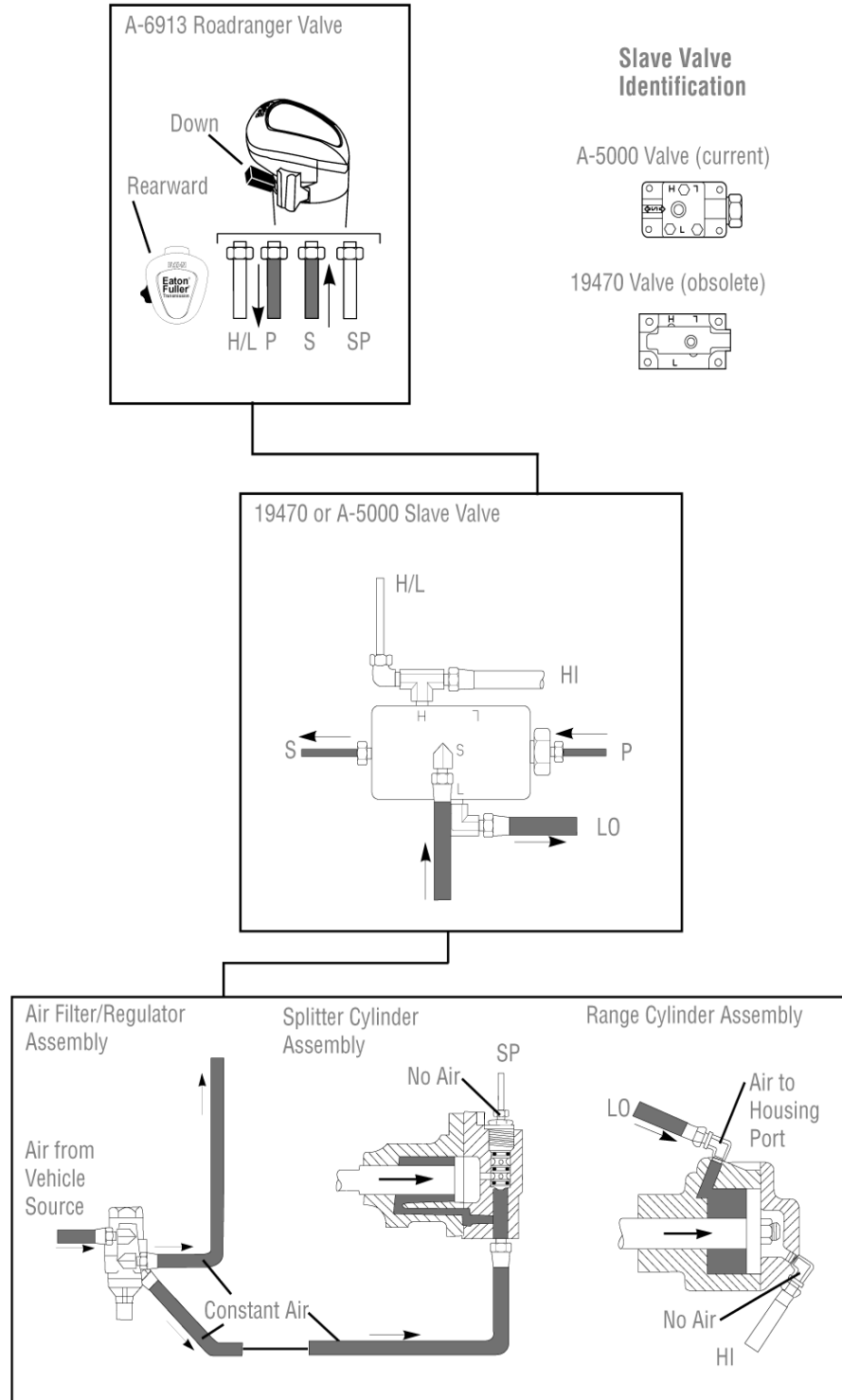

## HI Range L

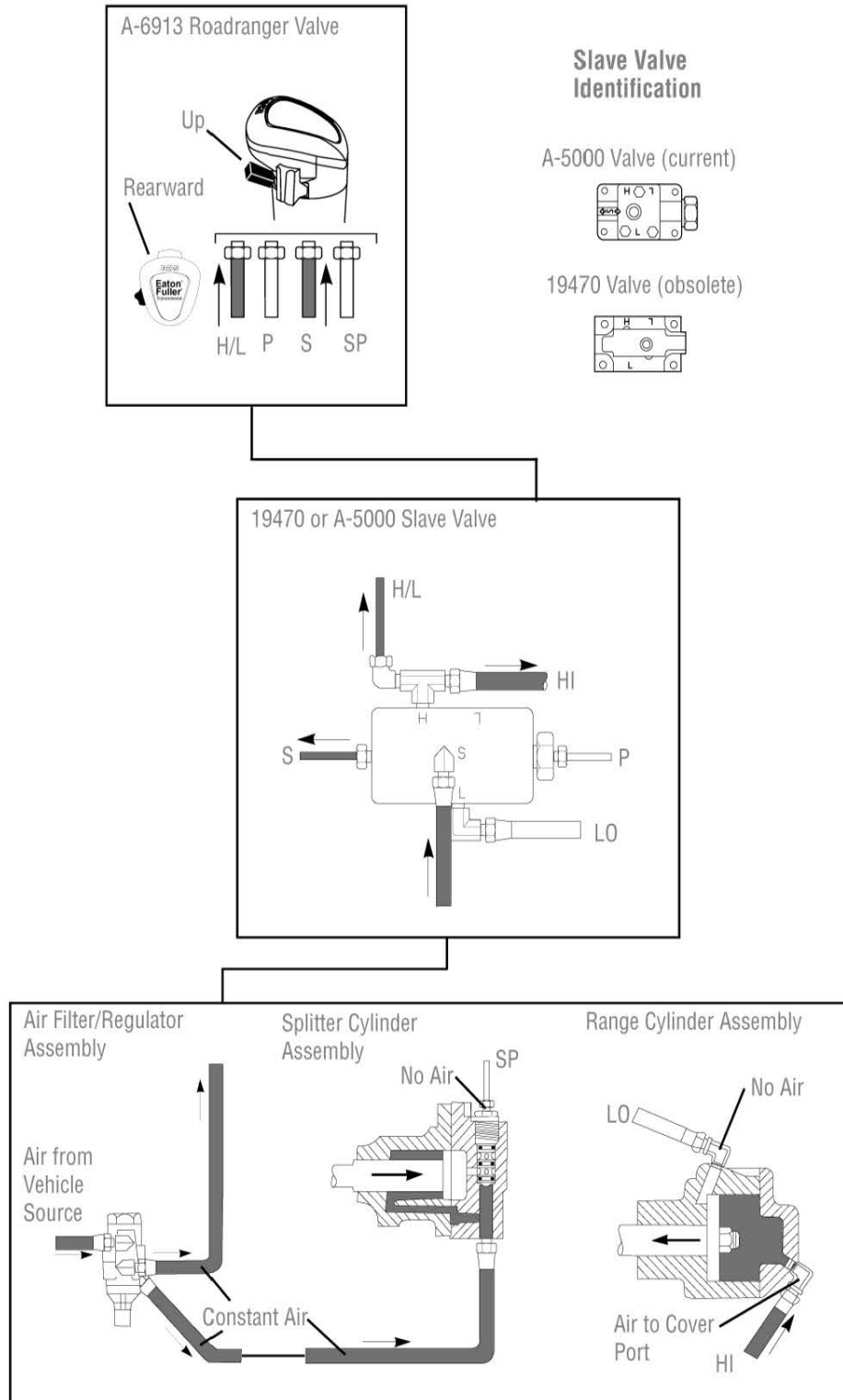

Operation

# Operation

## HI Range H

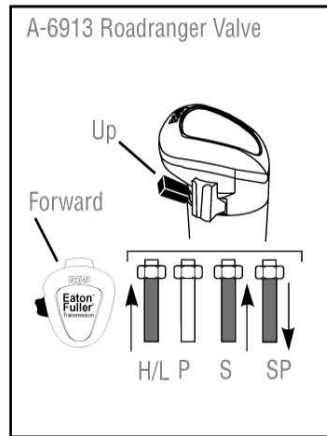

### Slave Valve Identification

A-5000 Valve (current)

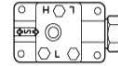

19470 Valve (obsolete)

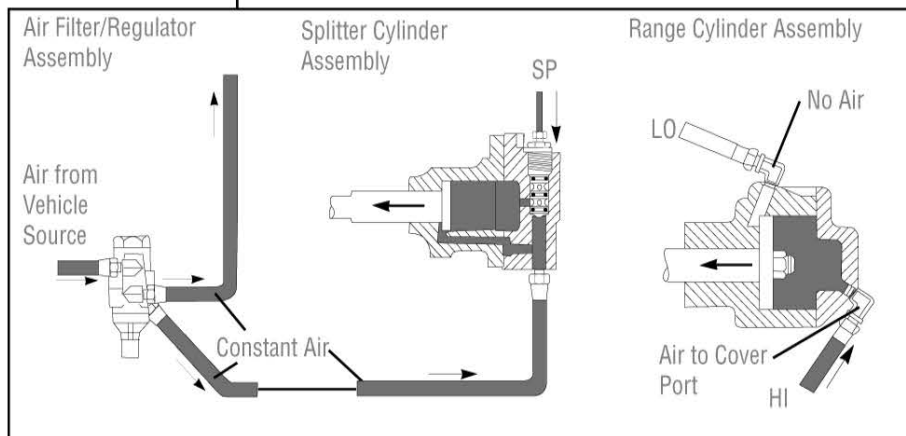
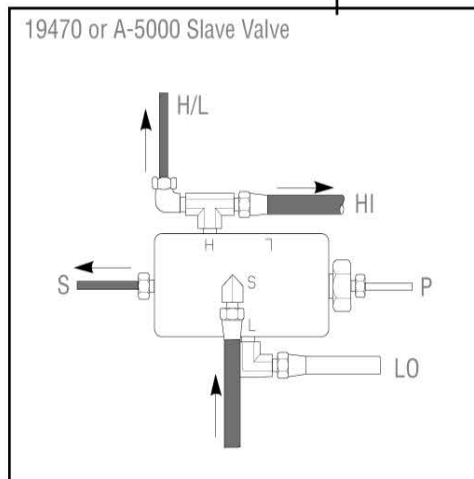
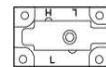

## RTLO-xx713 Models

LO Range

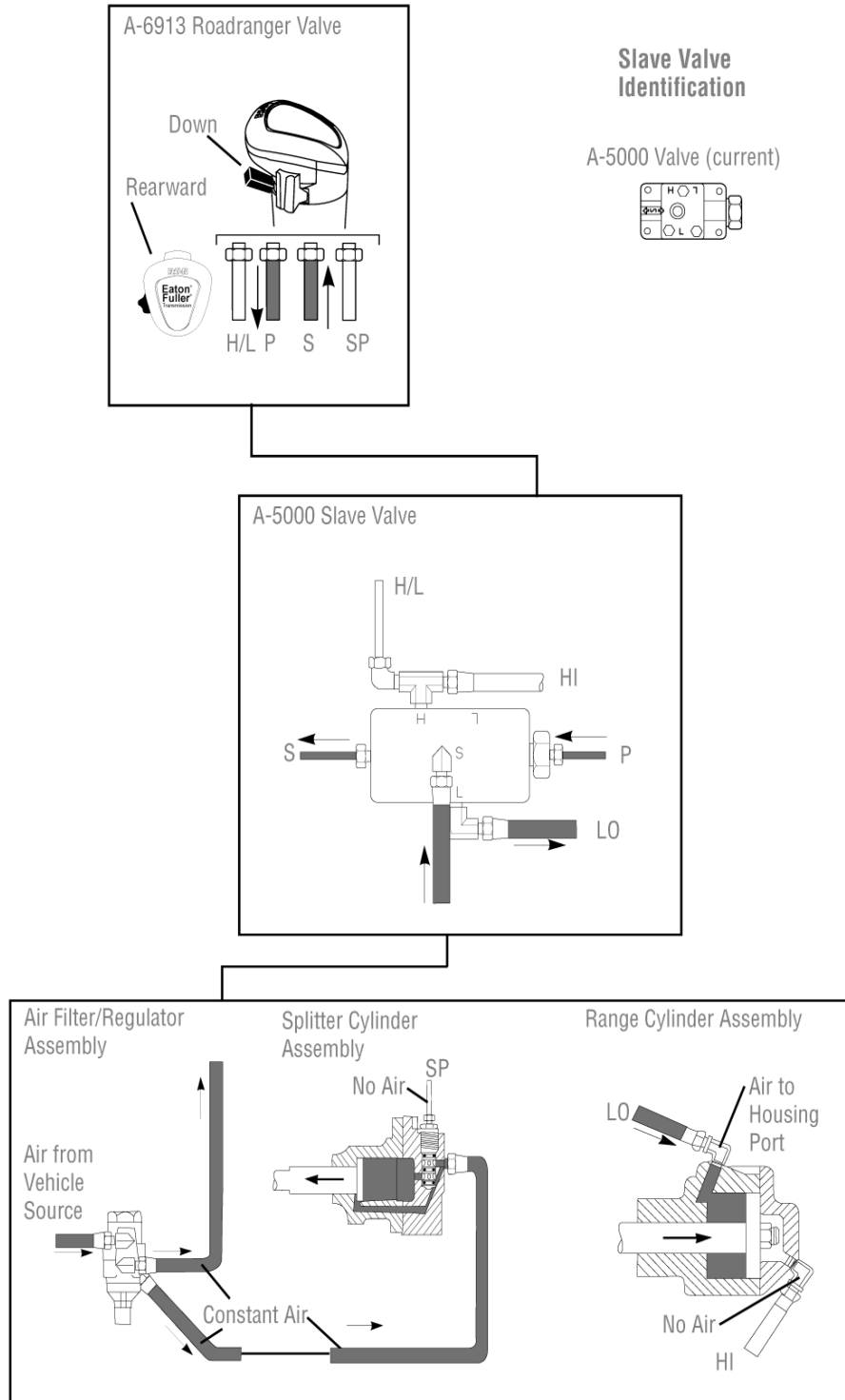

Operation

# Operation

## HI Range L

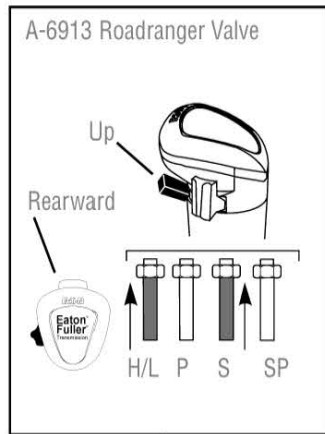

### Slave Valve Identification

A-5000 Valve (current)

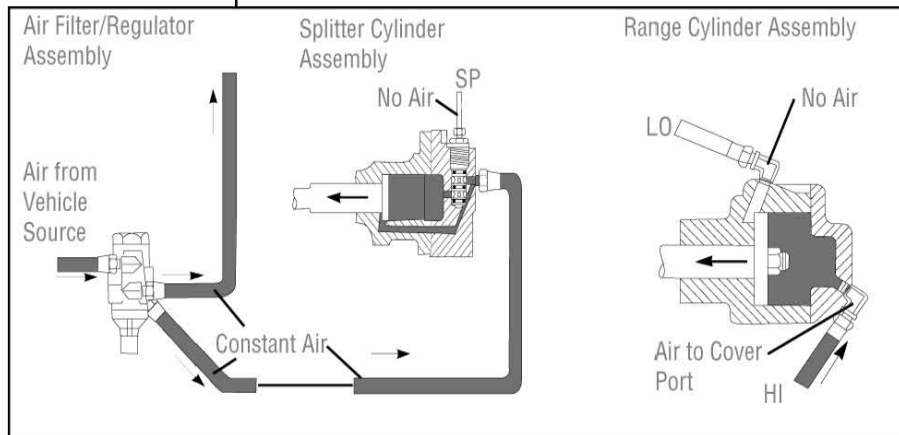
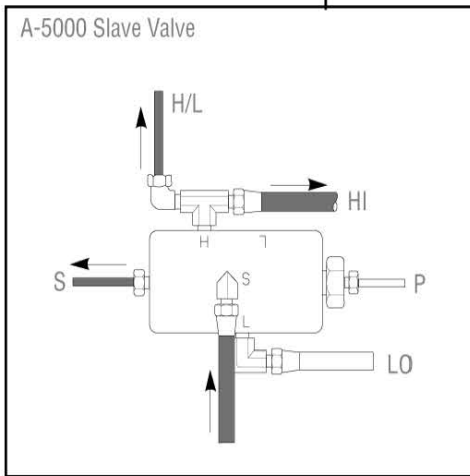
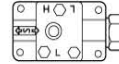

## HI Range H

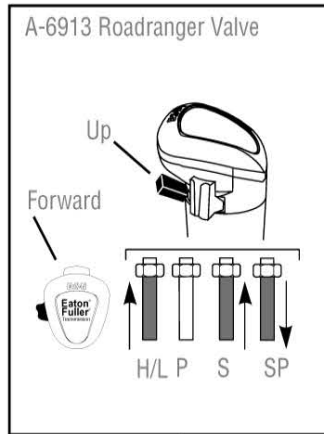

## Slave Valve Identification

A-5000 Valve (current)

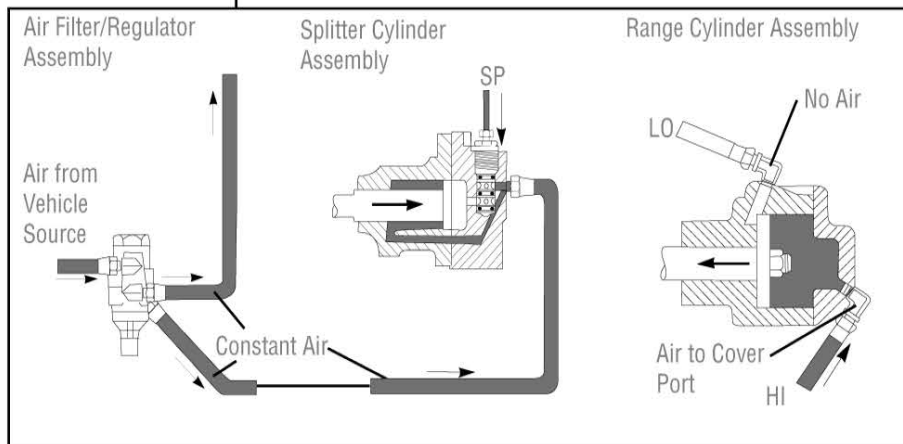
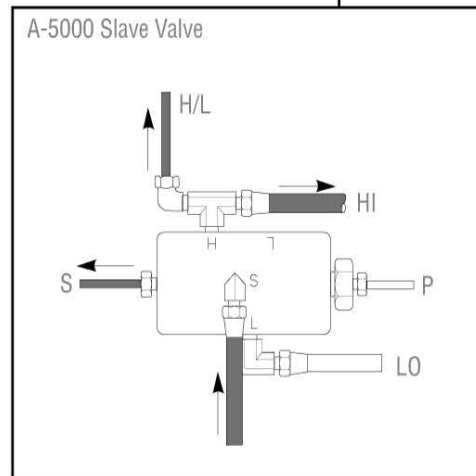
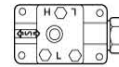

Operation



# Operation

## RTLO-xx913 Models

### LO Range Low Split

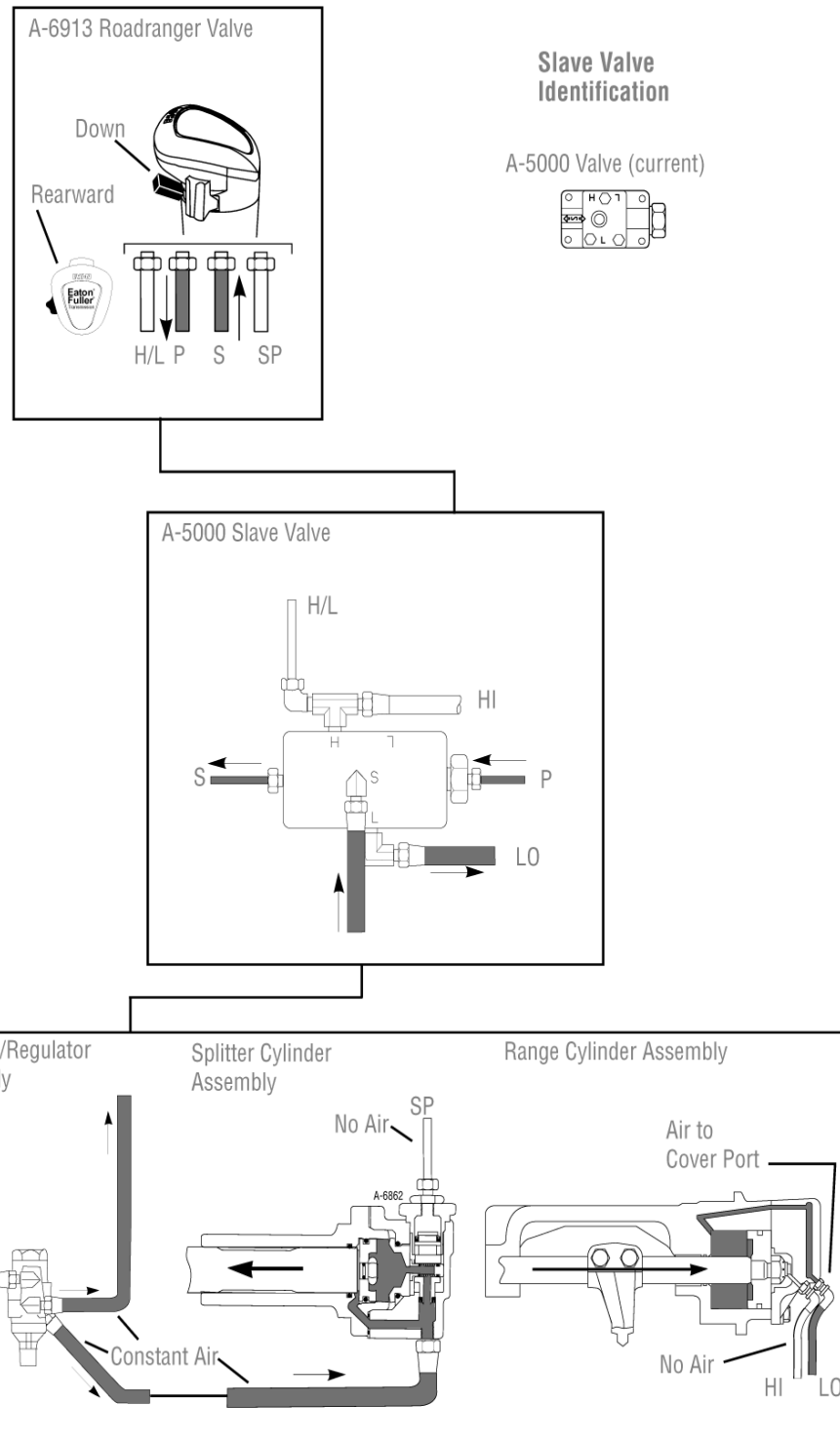

## HI Range Low Split

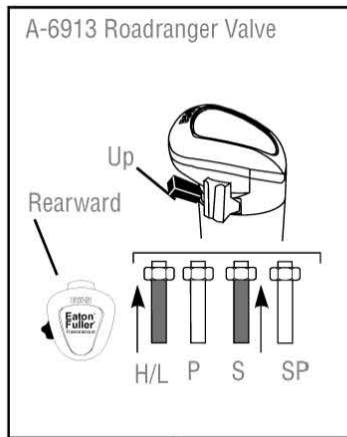

## Slave Valve Identification

A-5000 Valve (current)

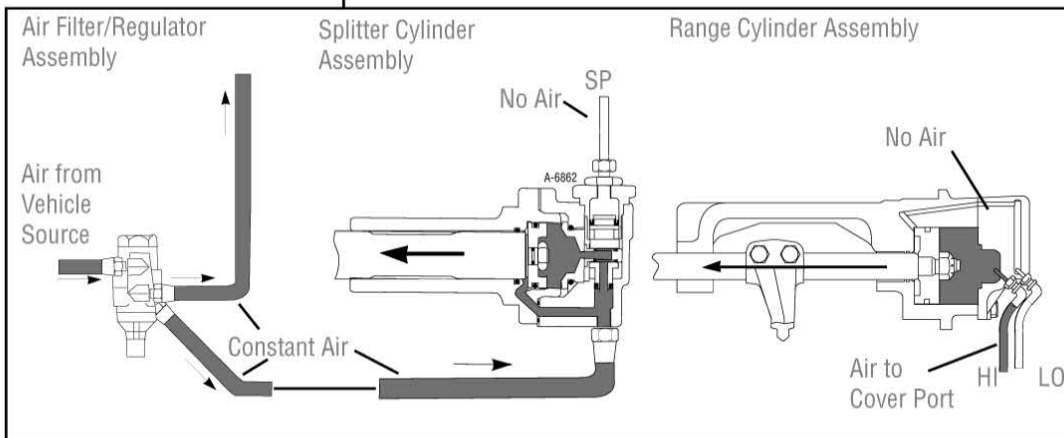
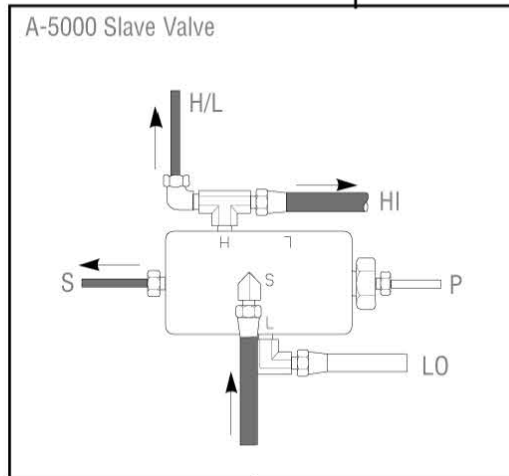
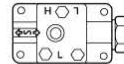

Operation

# Operation

## HI Range High Split

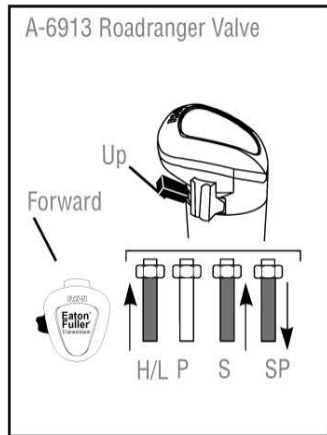

## Slave Valve Identification

A-5000 Valve (current)

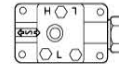

## A-5000 Slave Valve

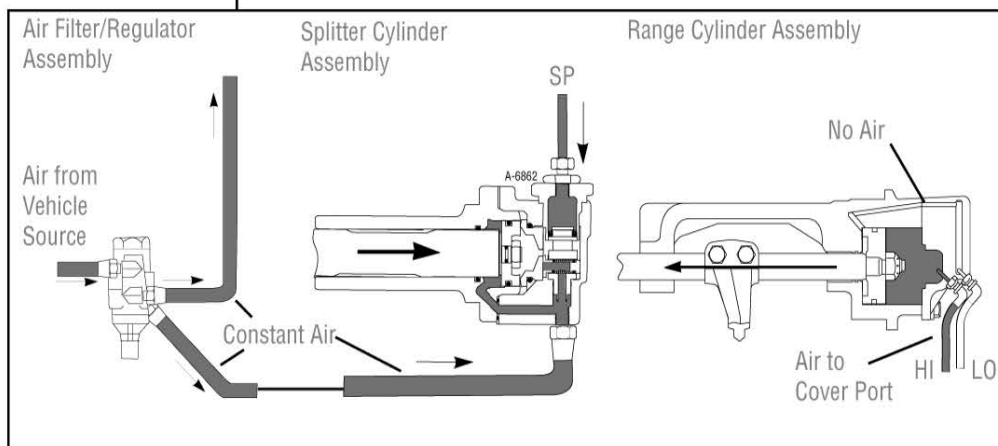
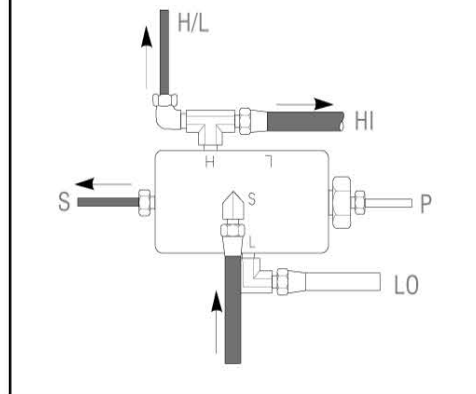

## RT0-15618 and RTLO-xx618 Models

### LO Range L

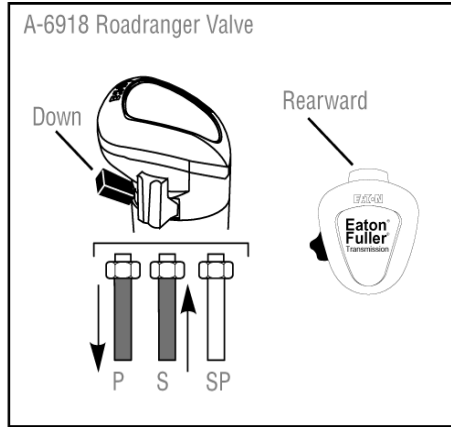

### Slave Valve Identification

A-5000 Valve (current)

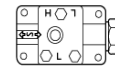

19470 Valve (obsolete)

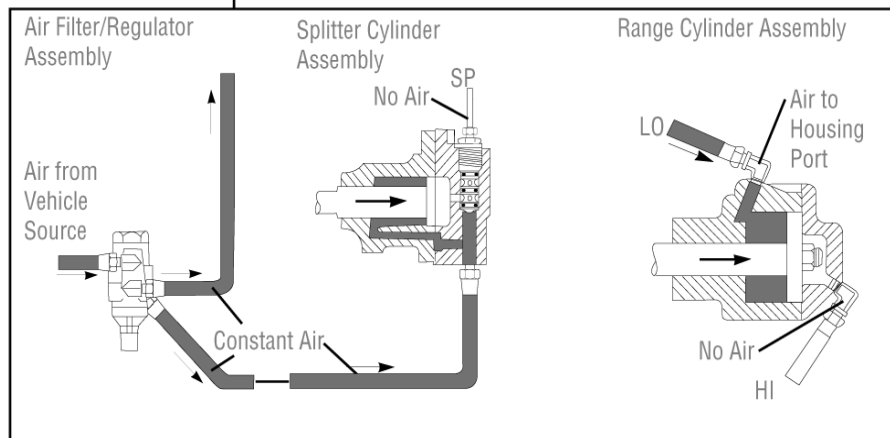
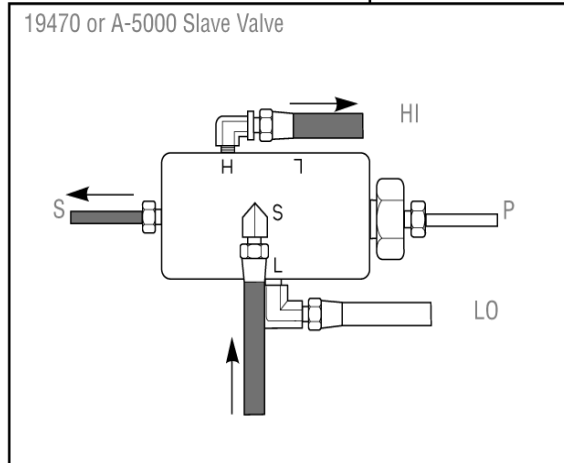
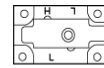

Operation

# Operation

## LO Range H

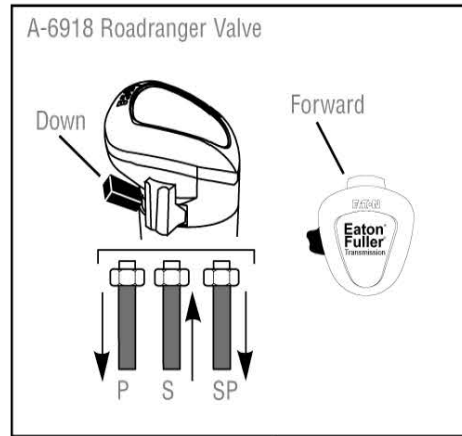

### Slave Valve Identification

A-5000 Valve (current)

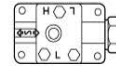

19470 Valve (obsolete)

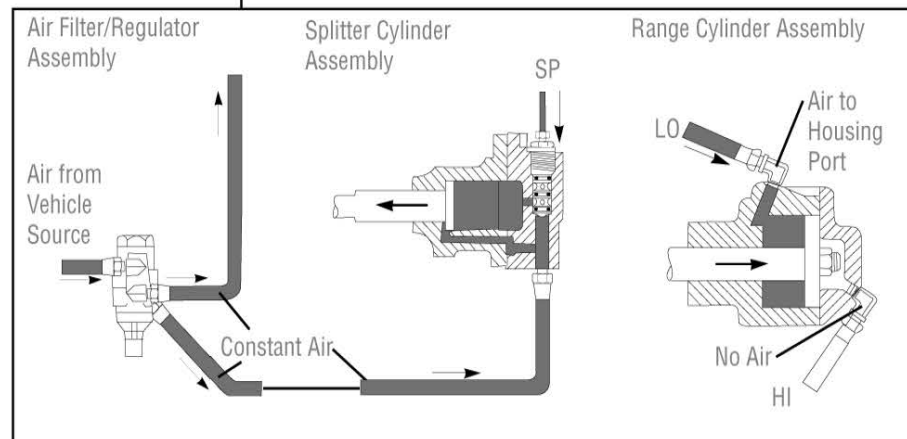
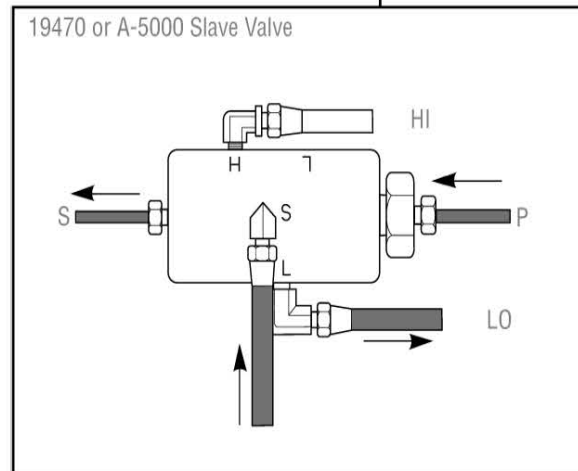
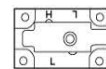

## HI Range L

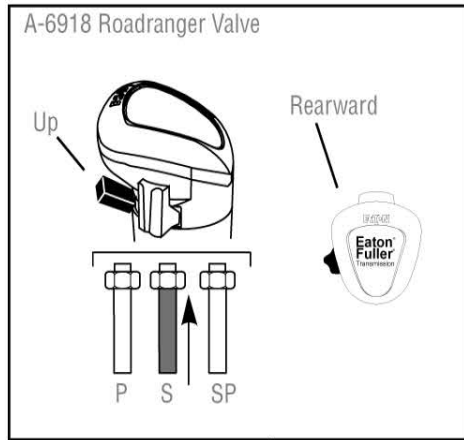

### Slave Valve Identification

A-5000 Valve (current)

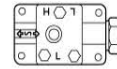

19470 Valve (obsolete)

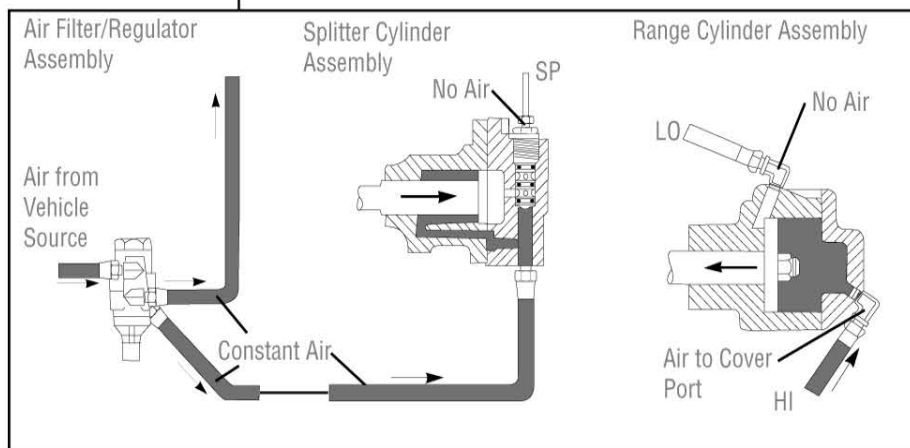
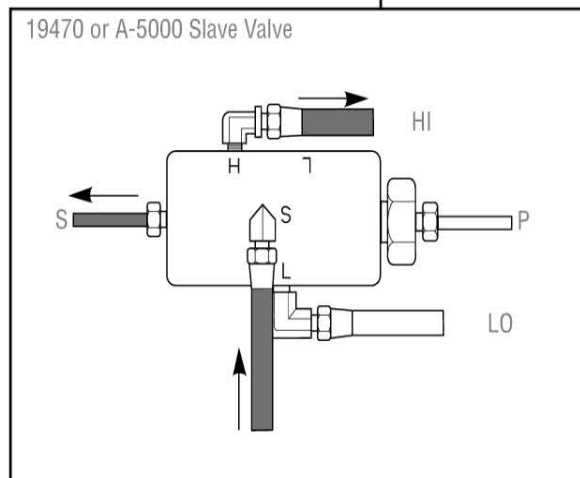
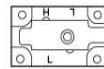

Operation

# Operation

## HI Range H

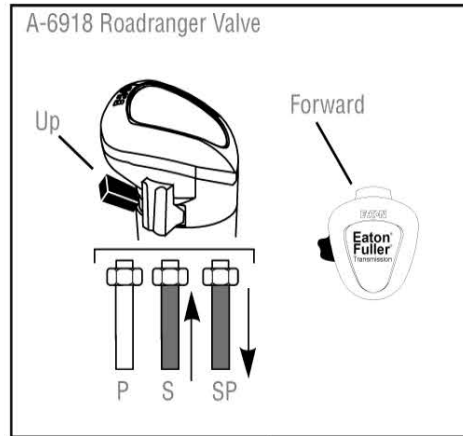

### Slave Valve Identification

A-5000 Valve (current)

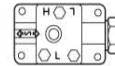

19470 Valve (obsolete)

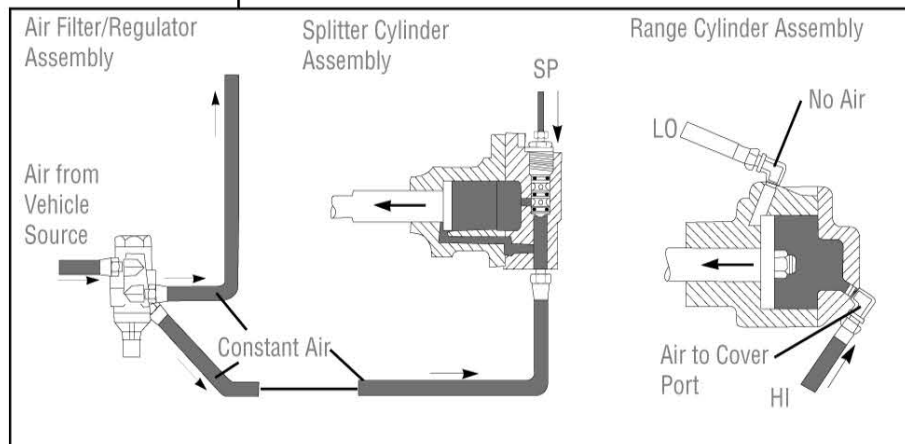
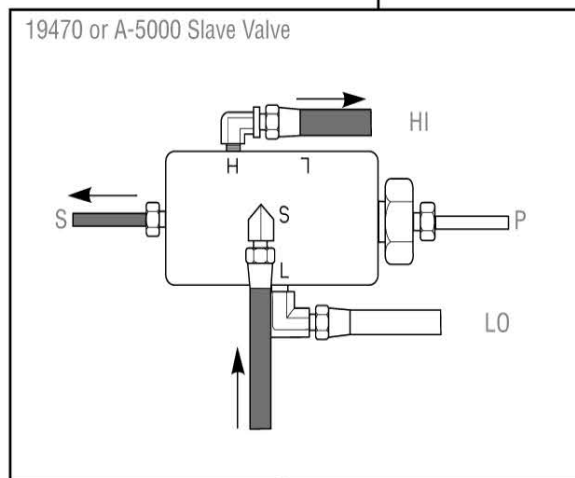
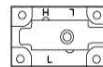

RTLO-xx718 Models

LO Range L

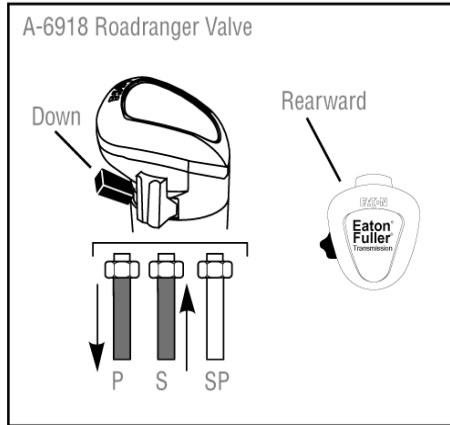

Slave Valve Identification

A-5000 Valve (current)

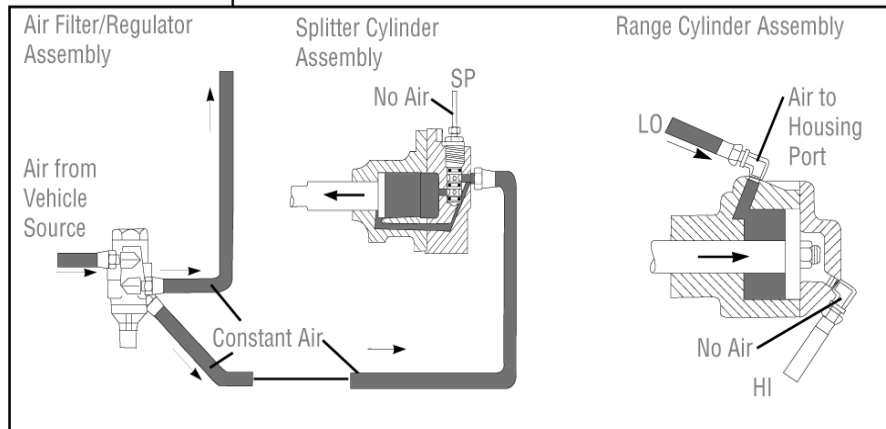
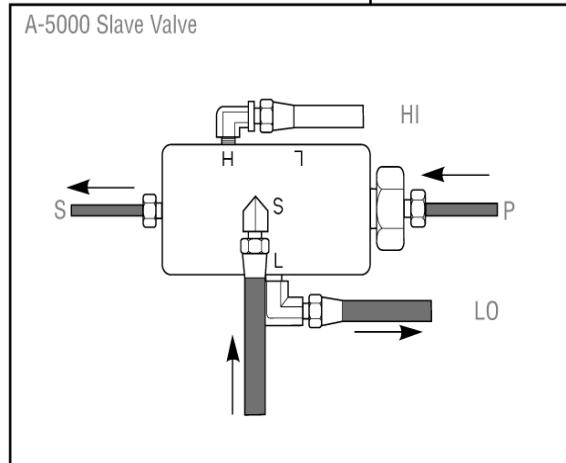
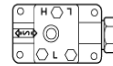

Operation



# Operation

## LO Range H

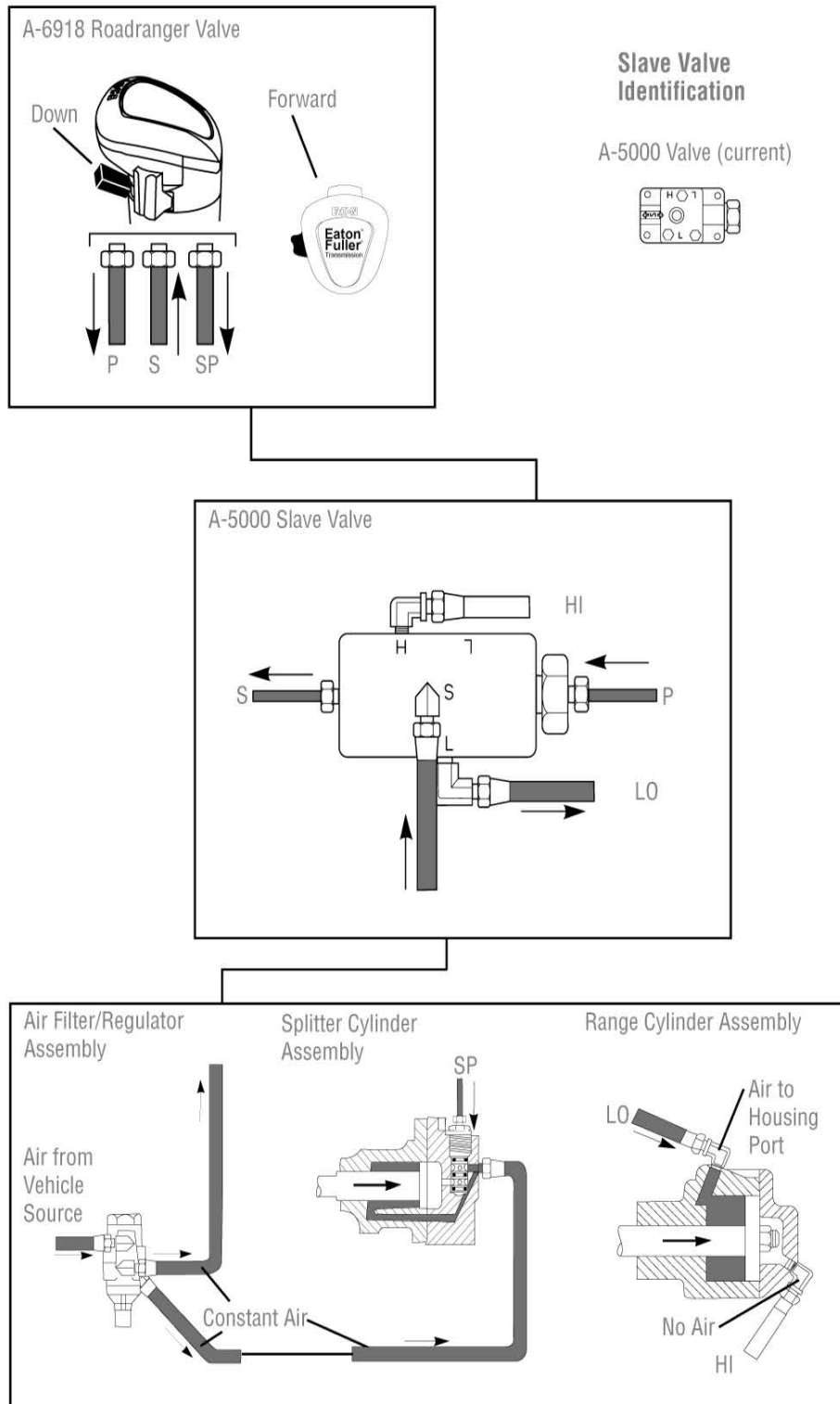

## HI Range L

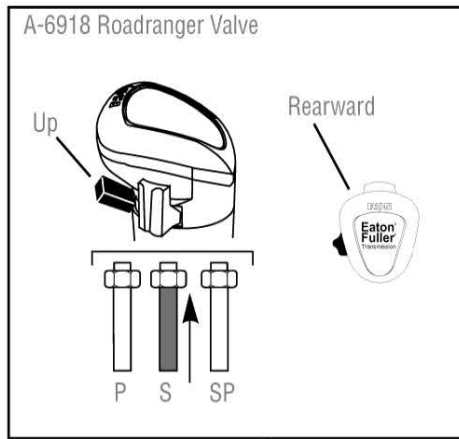

### Slave Valve Identification

A-5000 Valve (current)

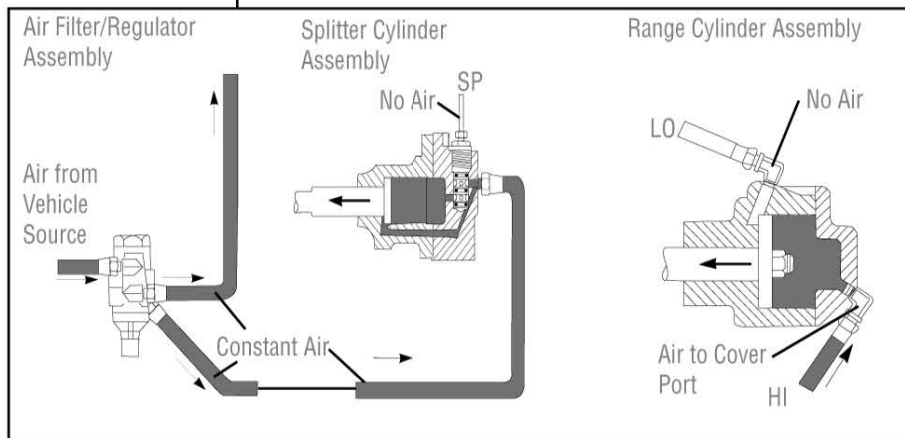
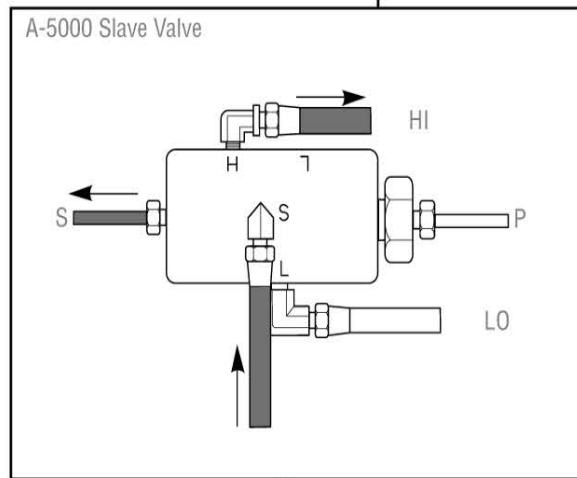
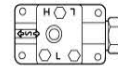

Operation

# Operation

## HI Range H

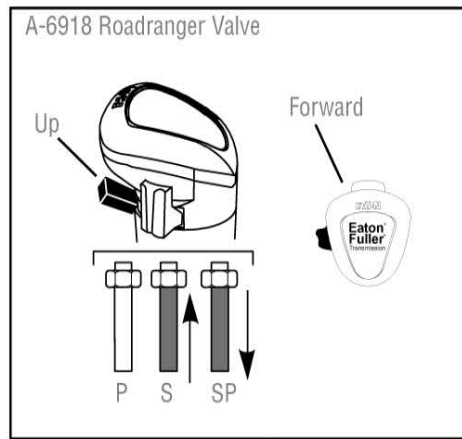

## Slave Valve Identification

A-5000 Valve (current)

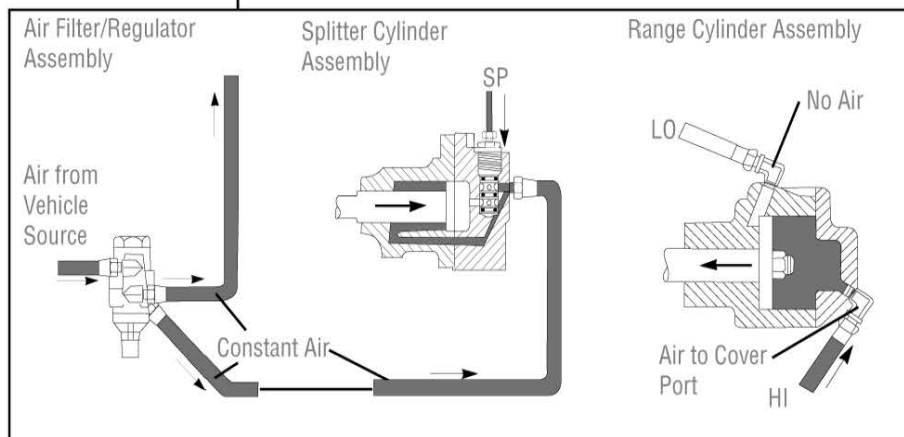
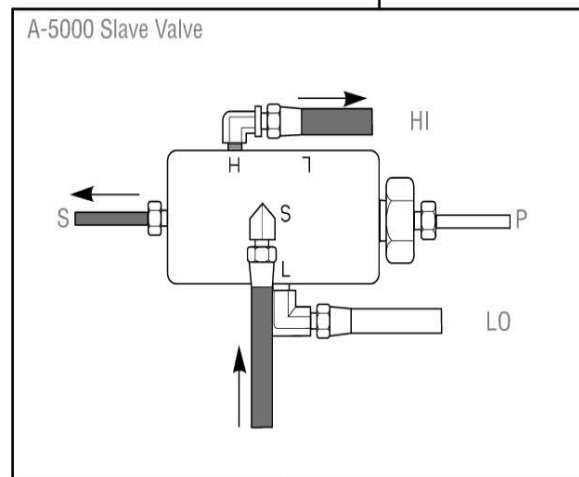
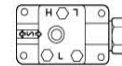

## RTLO-xx918 Models

### LO Range L

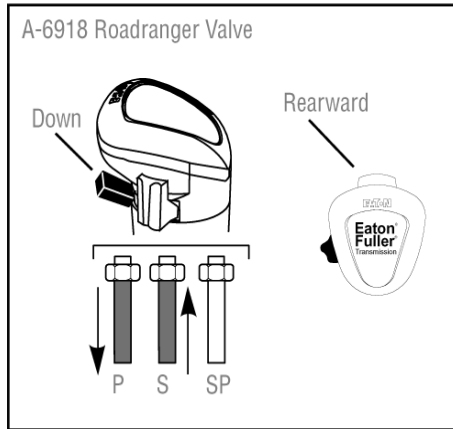

### Slave Valve Identification

A-5000 Valve (current)

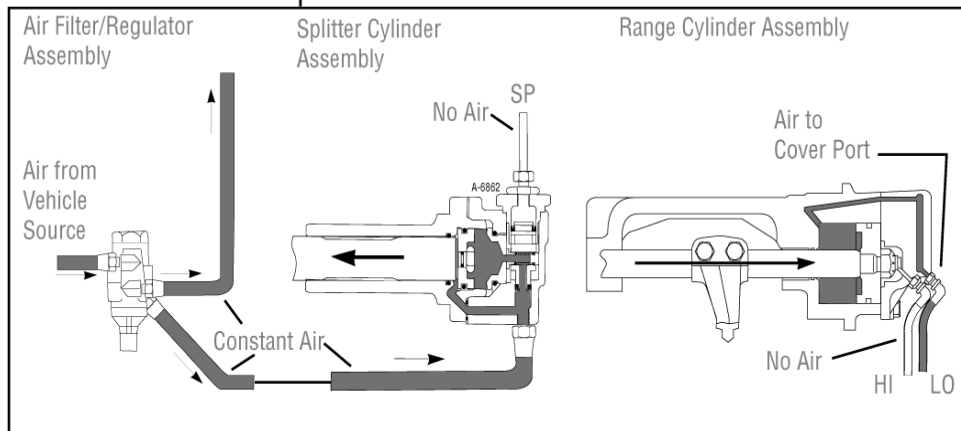
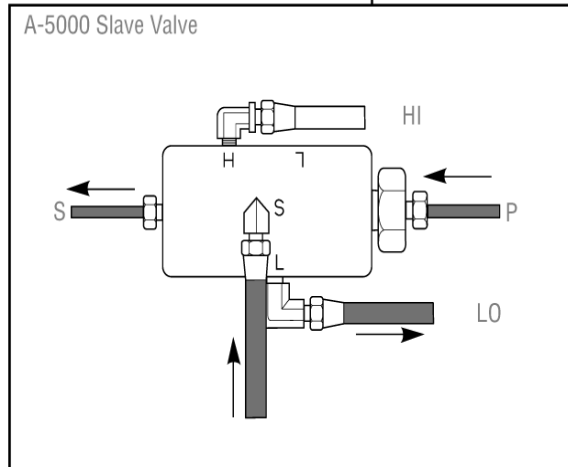
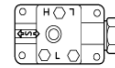

Operation

# Operation

## LO Range H

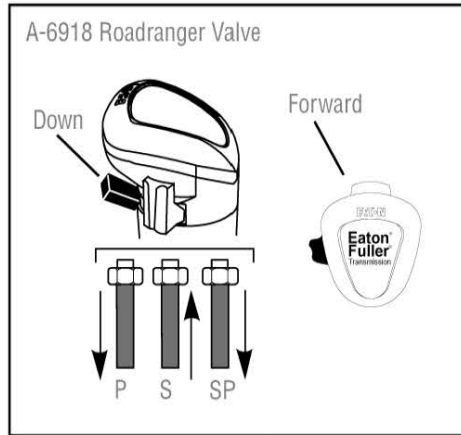

### Slave Valve Identification

A-5000 Valve (current)

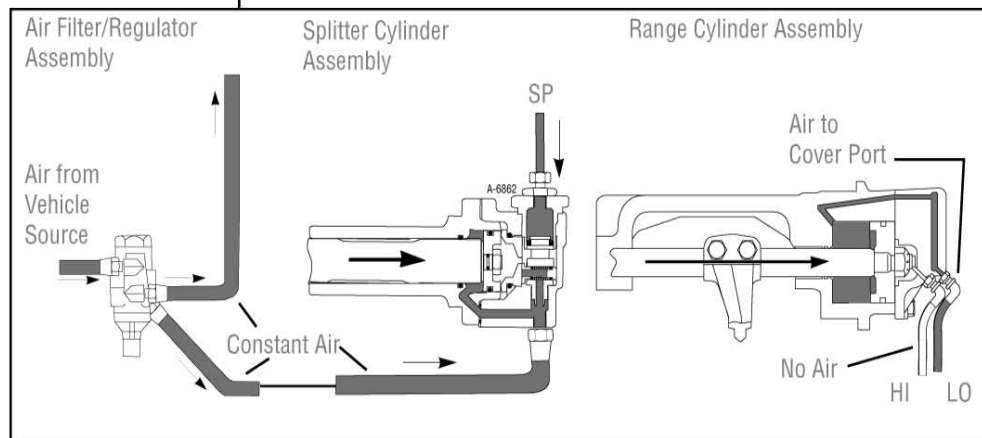
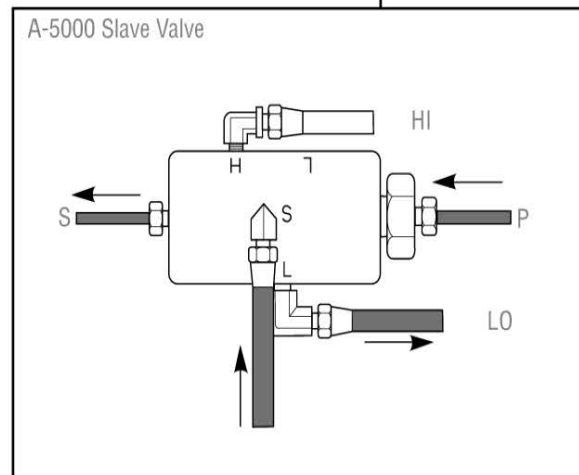
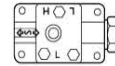

## HI Range L

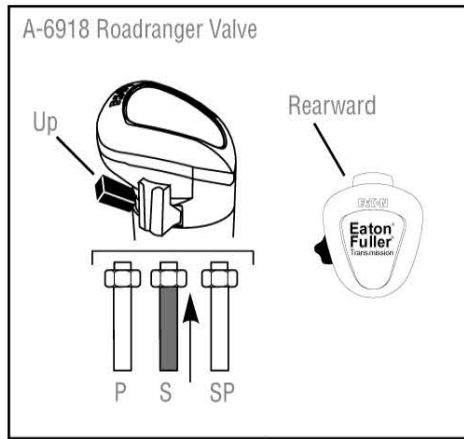

### Slave Valve Identification

A-5000 Valve (current)

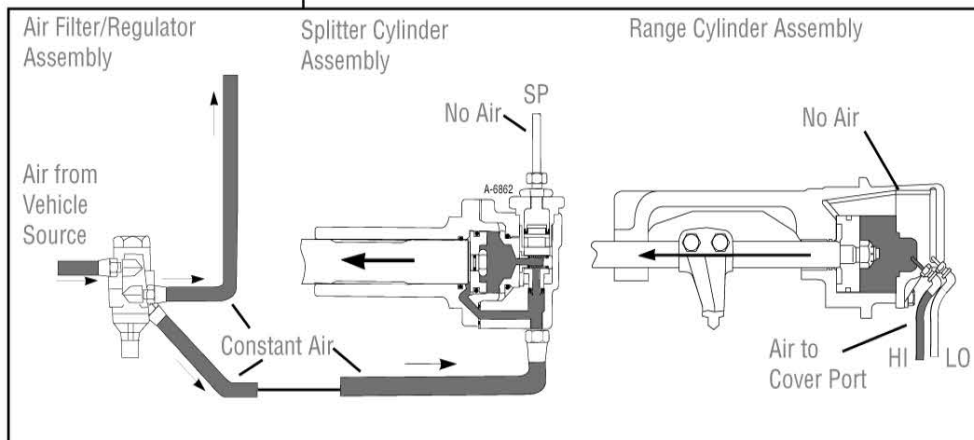
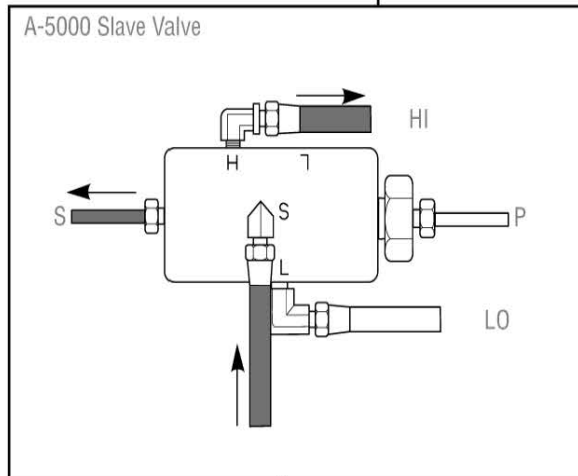
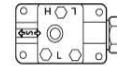

Operation

# Operation

## HI Range H

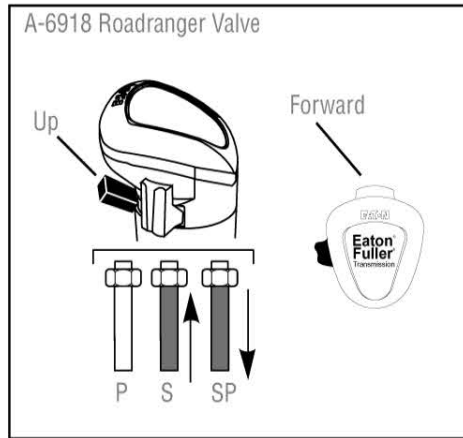

## Slave Valve Identification

A-5000 Valve (current)

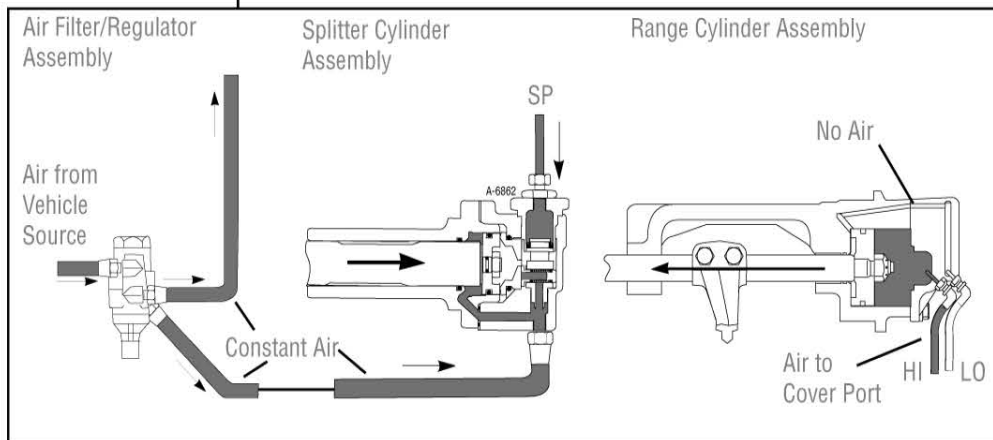
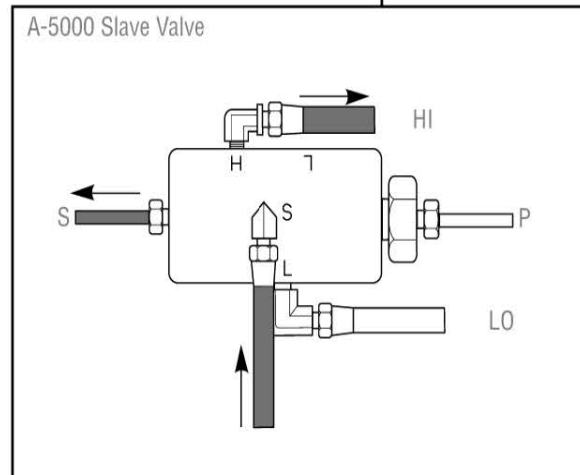
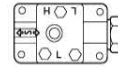

## Combination Cylinder Air System

The combination cylinder air system functions much like the other air systems except the range cylinder and the deep reduction cylinder are located side by side in the same housing.

Air is supplied to the system at the air supply port (1) by the vehicle's air system. The air filter removes foreign matter from the air then allows it to pass through the air regulator where the pressure is adjusted for 58 to 63 PSI (4.0 daN/cm<sup>2</sup>). From there the air passes through the supply air hose (2) to the slave valve supply port (3) through the supply air line (4) to the Roadranger valve.

Depending upon the position of the range lever (5), air passes through either the LO range air line (6) or the HI range air line (7) to the range cylinder.

Depending upon the position of the splitter button (8), if air passes through the air line (9) connected to the deep reduction port (10) then the deep reduction gearing is engaged. If there is no air, the constant air from the air filter/regulator assembly moves the deep reduction piston forward to disengage deep reduction gear.

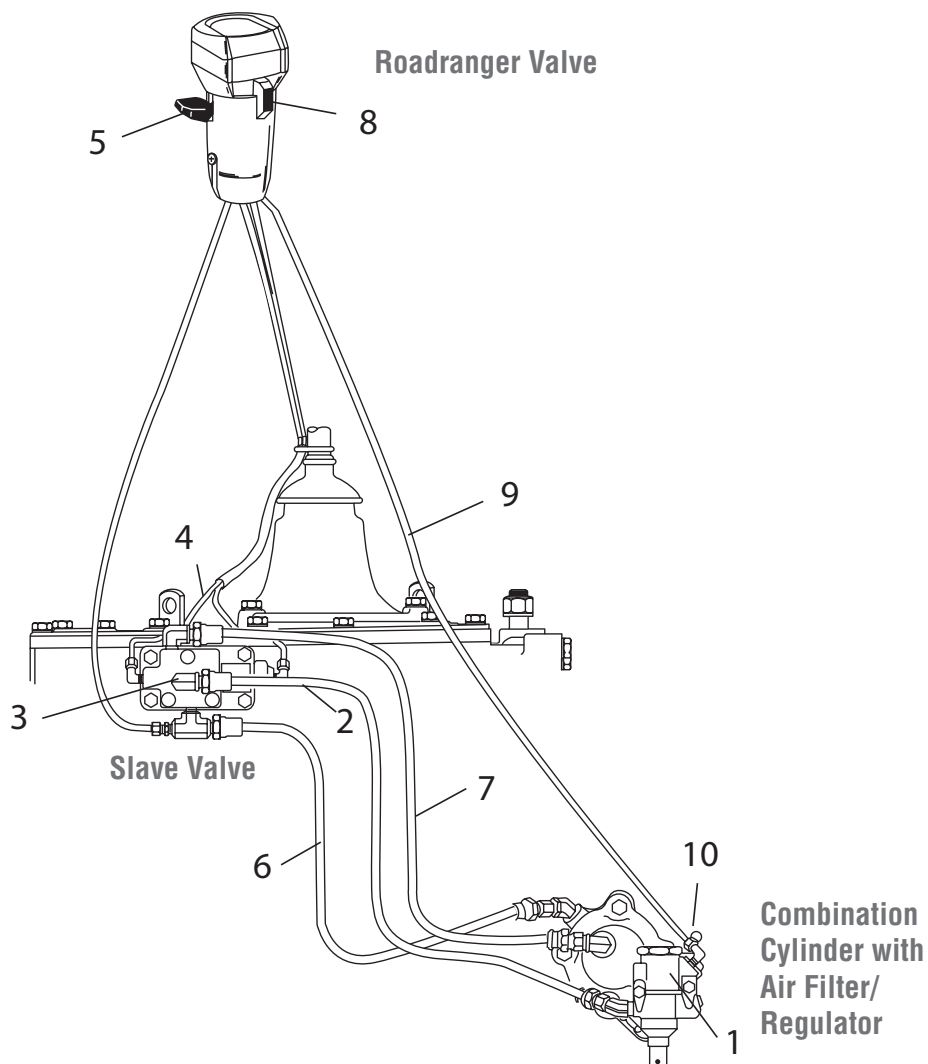

Operation



# Operation

## 7LL/DLL/MLL, 8LL, 9MLL, and 15-Speed Models

### Deep Reduction/Low-Low

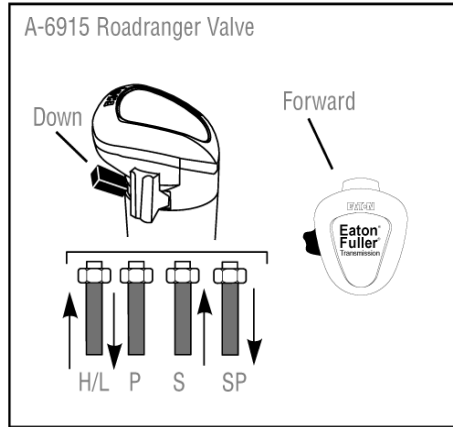

### Slave Valve Identification

A-5000 Valve (current)

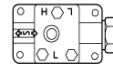

19470 Valve (obsolete)

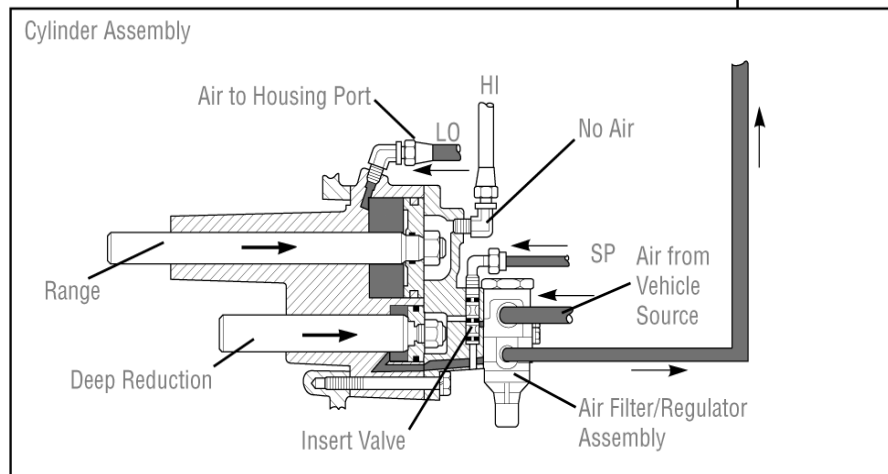
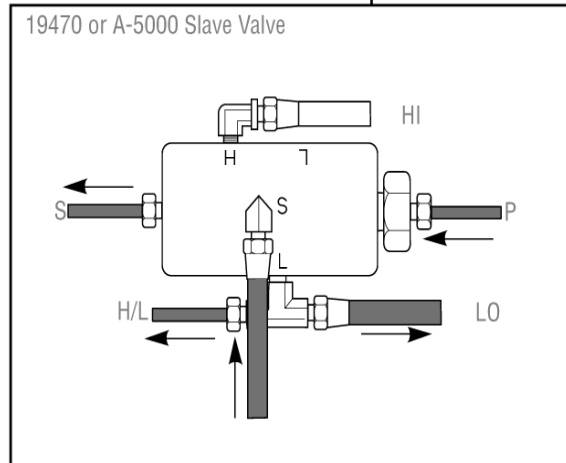
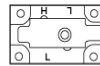

## Range—LO

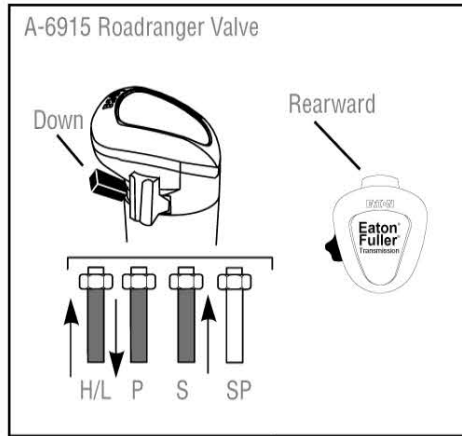

### Slave Valve Identification

A-5000 Valve (current)

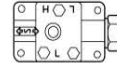

19470 Valve (obsolete)

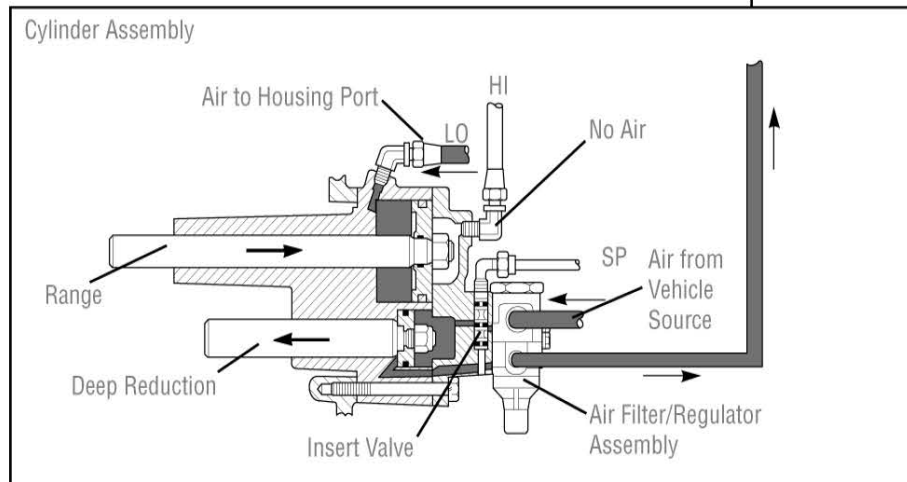
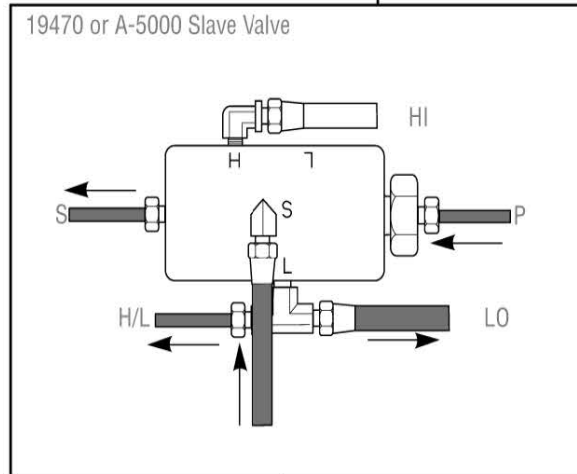
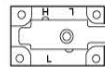

Operation

# Operation

Range—HI

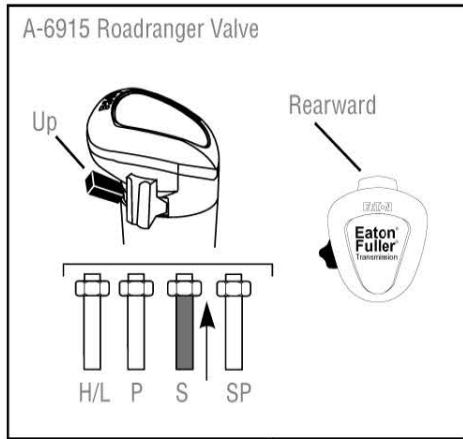

## Slave Valve Identification

A-5000 Valve (current)

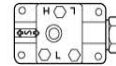

19470 Valve (obsolete)

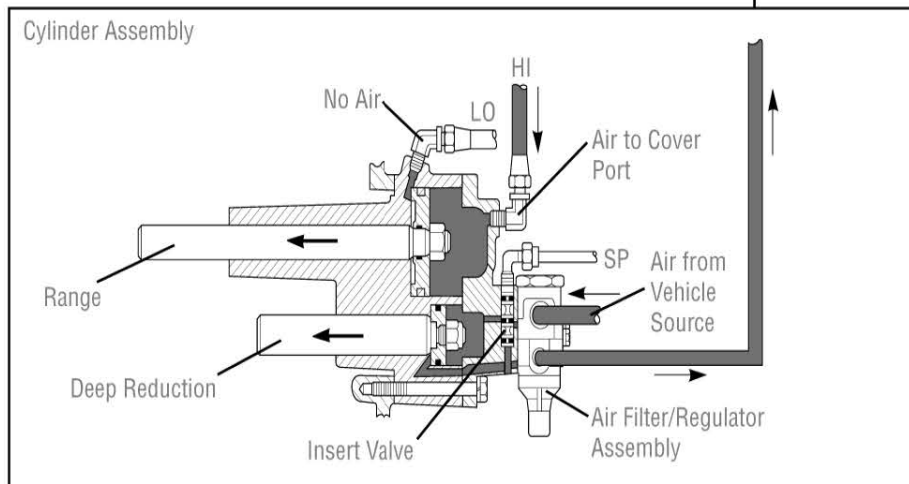
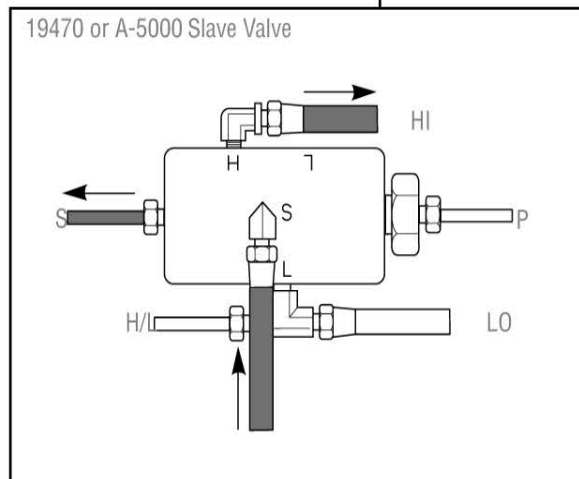
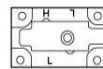

## Unique Air Systems

**Note:** Eaton recommends that you update using the latest air systems to prevent possible synchronizer failure.

### RT & RTO 613 and 6613 Air Systems (With 3-Position Selector Valve)

This system consists of a 3-Position Selector valve and an intermediate shift cylinder in addition to the range cylinder. The intermediate shift cylinder shifts the transmission between LO range and intermediate. The range cylinder shifts the transmission between intermediate and direct.

Air is supplied to the system at the air supply port (1) by the vehicle's air system. The air filter (2) removes foreign matter from the air then allows it to pass through the air regulator (3) where the pressure is adjusted for 58 to 63 PSI (4.0 daN/cm<sup>2</sup>). From there the air passes through the supply air hose (4) to the slave valve supply port (5) through the supply air line to the control valve (6).

Depending upon the position of the control button (7), if air passes through the air line (8) connected to the intermediate shift cylinder center port (9) then the intermediate/direct gearing is disengaged. If there is no air, the constant air from the air filter/regulator assembly (10) moves the intermediate piston forward to engage LO gearing.

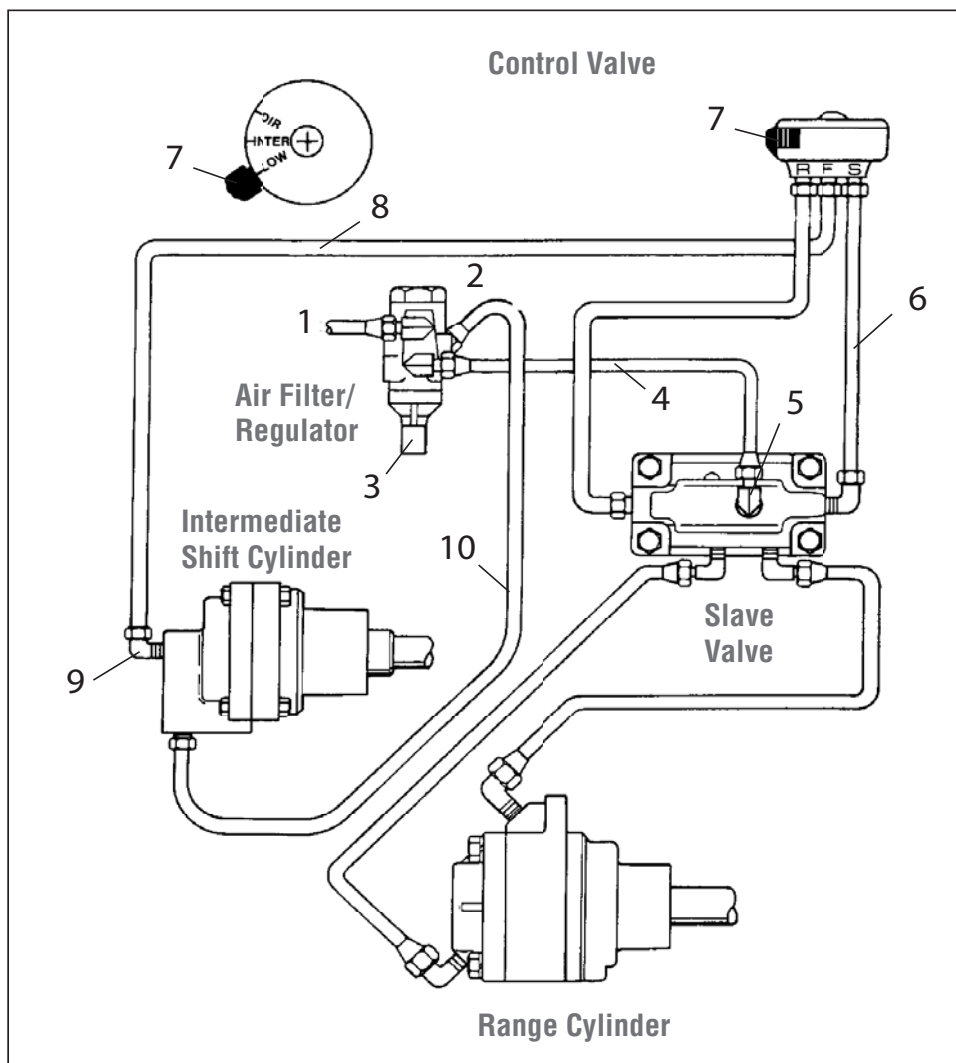

# Operation

## RT & RTO 613 and 6613 Models

LO Range

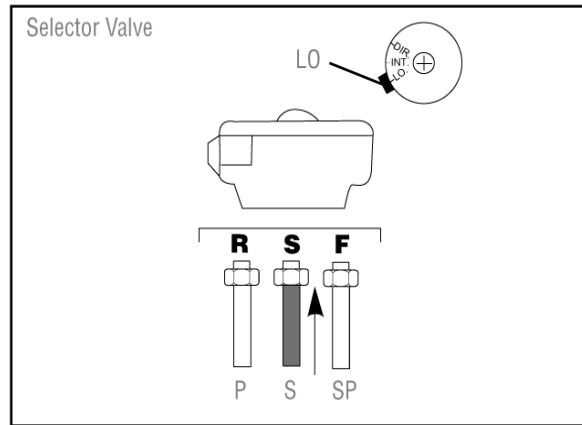

### Slave Valve Identification

A-4688 Valve (old)

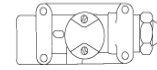

A-5000 Valve (current)

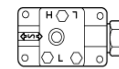

19470 Valve (obsolete)

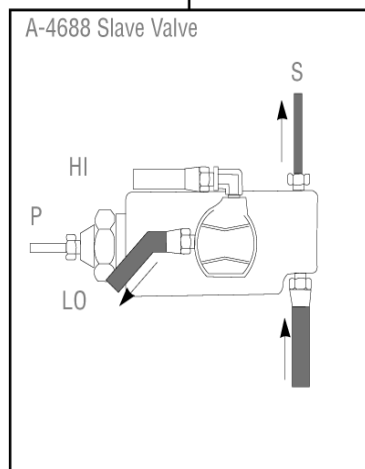
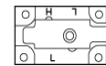

OR

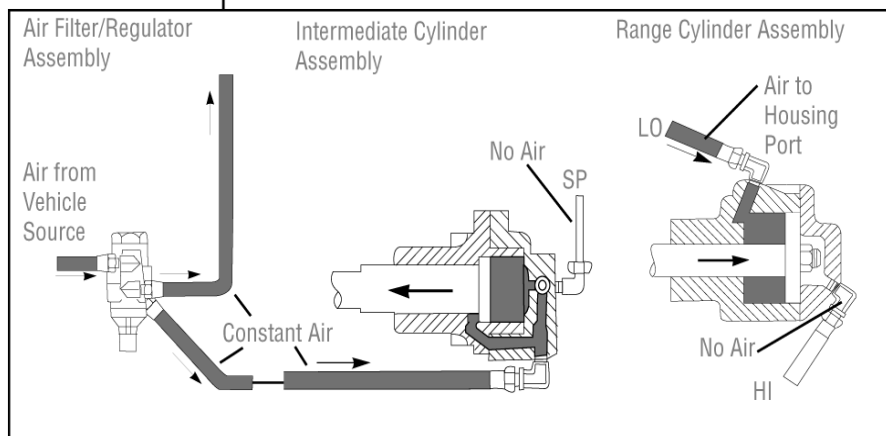
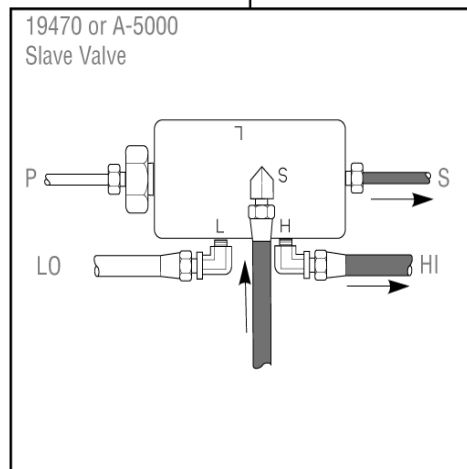

## Intermediate

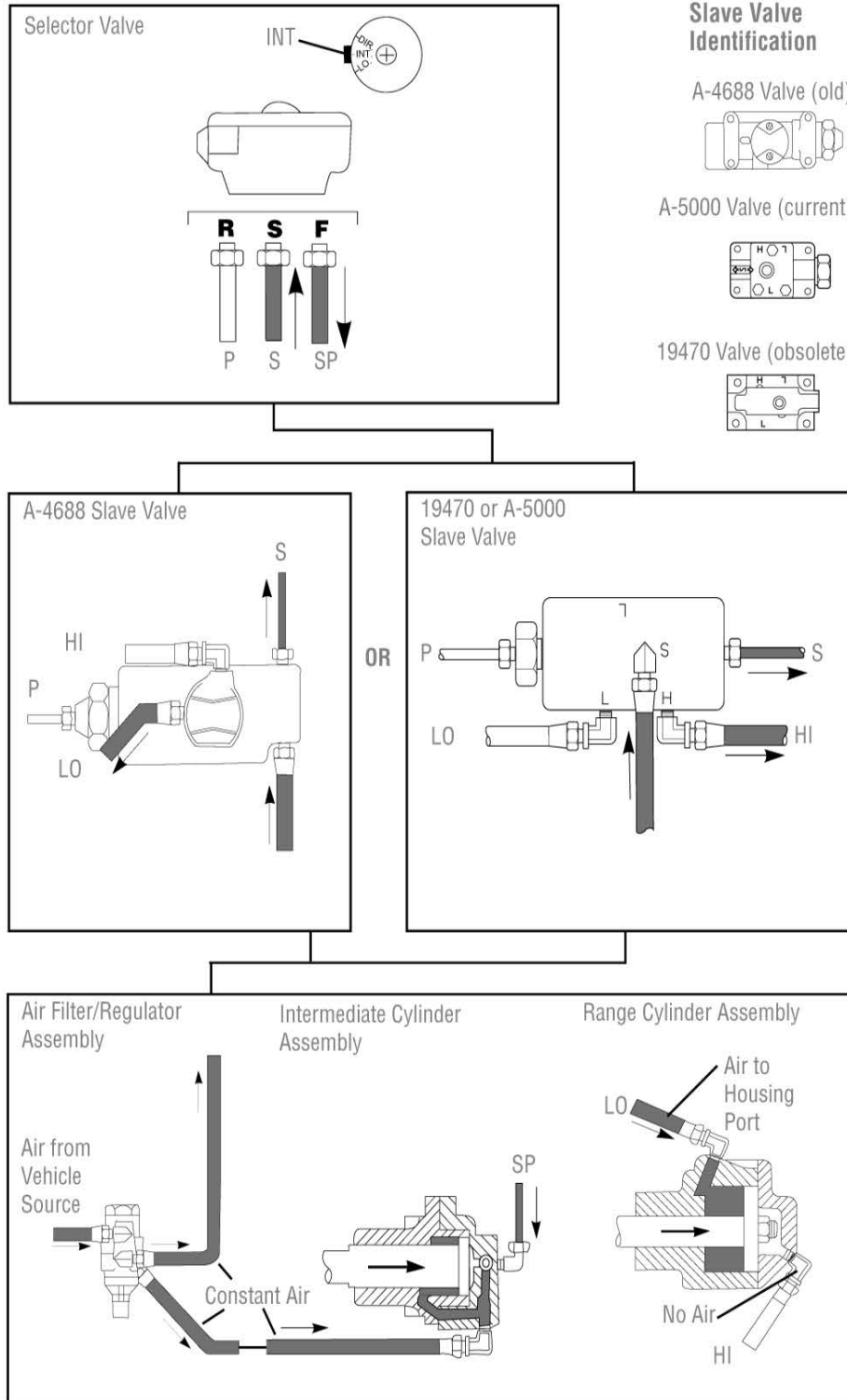

Operation

# Operation

## Direct

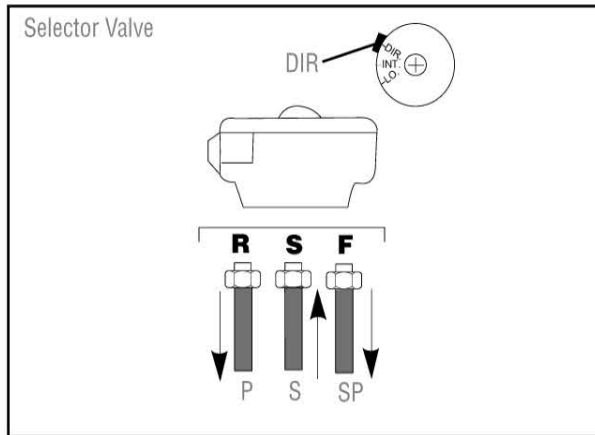

### Slave Valve Identification

A-4688 Valve (old)

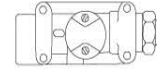

A-5000 Valve (current)

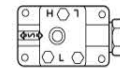

19470 Valve (obsolete)

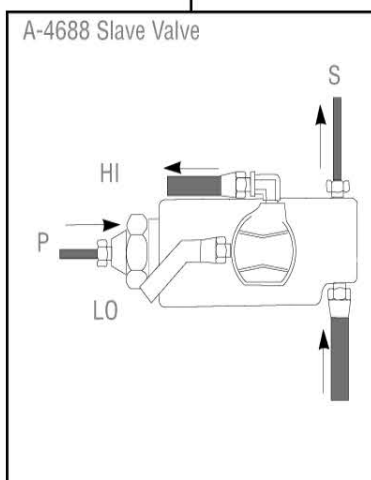
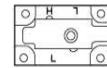

OR

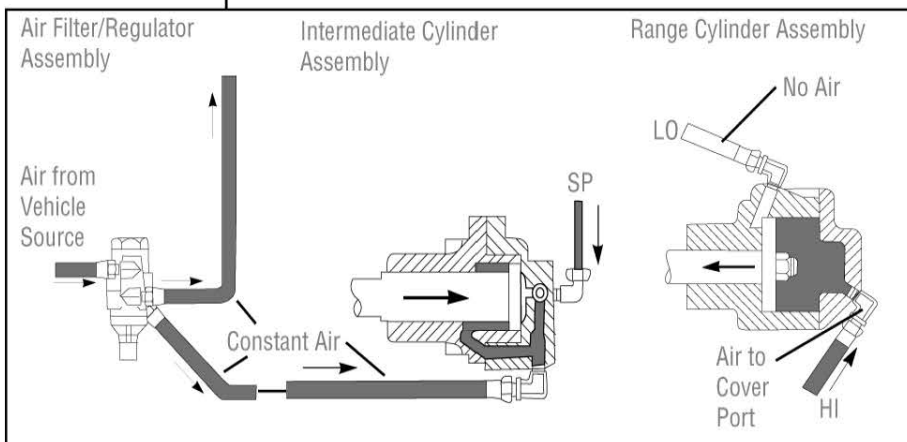
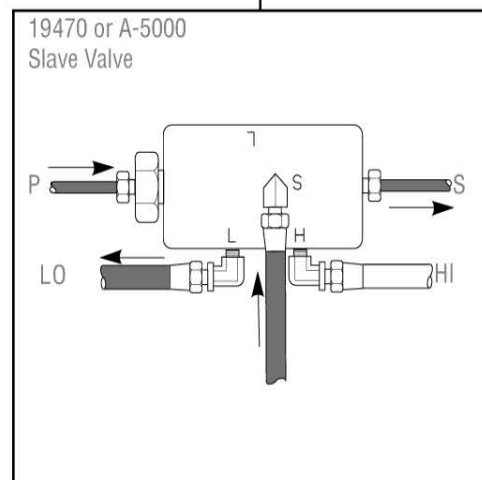

## RT & RTO 613 and 6613 Models With A-6913 Roadranger Valve

This system consists of a A-6913 Roadranger valve and an intermediate shift cylinder in addition to the range cylinder. The intermediate shift cylinder shifts the transmission between deep reduction and LO range, the range cylinder shifts the transmission between LO and HI range.

Air is supplied to the system at the air supply port (1) by the vehicle's air system. The air filter (2) removes foreign matter from the air then allows it to pass through the air regulator (3) where the pressure is adjusted for 58 to 63 PSI (4.0 daN/cm<sup>2</sup>). From there the air passes through the supply air hose (4) to the slave valve supply port (5) through the supply air line to the Roadranger valve (6).

Depending upon the position of the splitter button (7), if air passes through the air line (8) connected to the intermediate shift cylinder top port (9) then the deep reduction gearing is engaged. If there is no air, the constant air from the air filter/regulator assembly (10) moves the intermediate piston rearward to disengage deep reduction gearing.

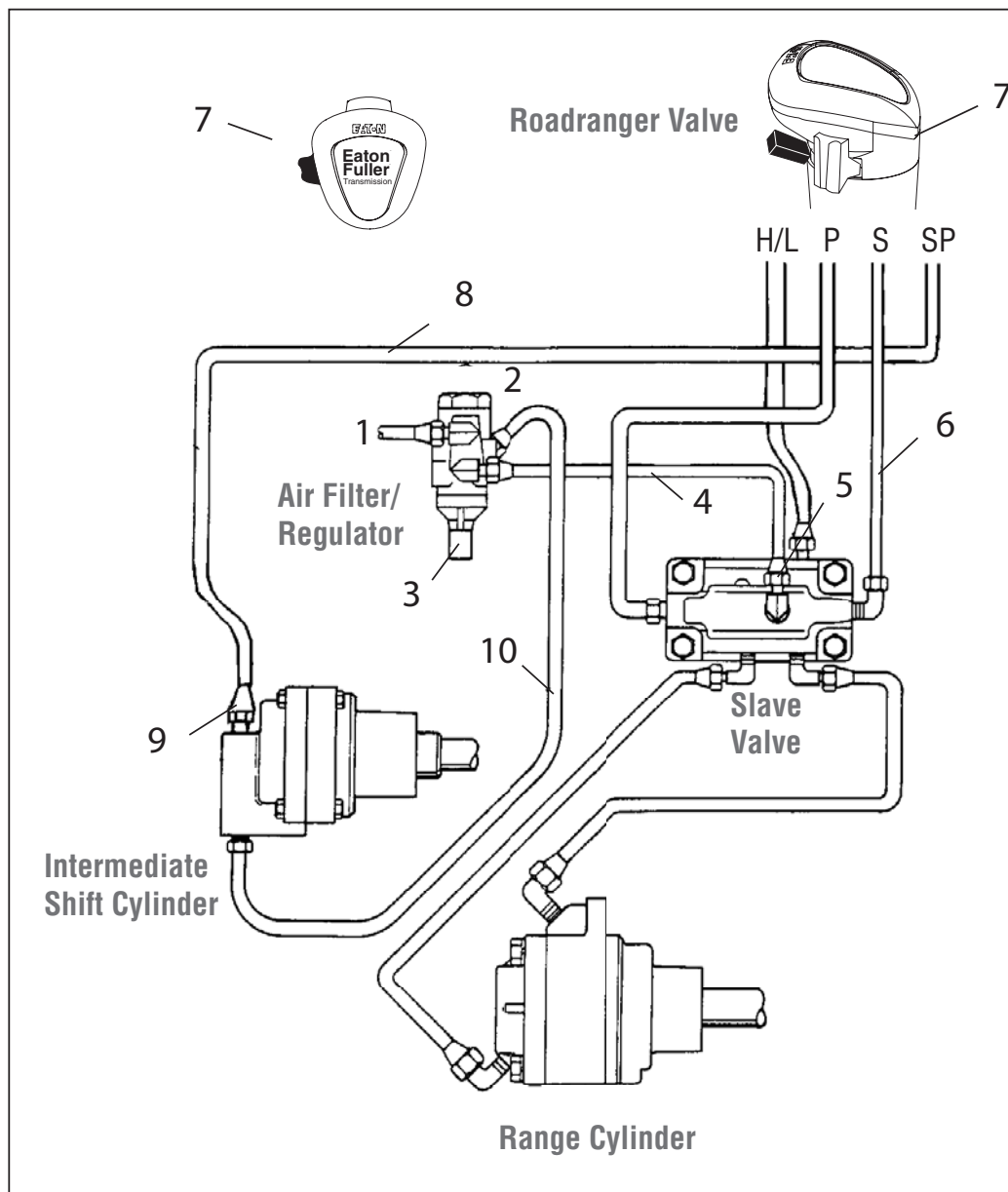

Operation



# Operation

## RT & RTO 613 and 6613 Models

### Deep Reduction

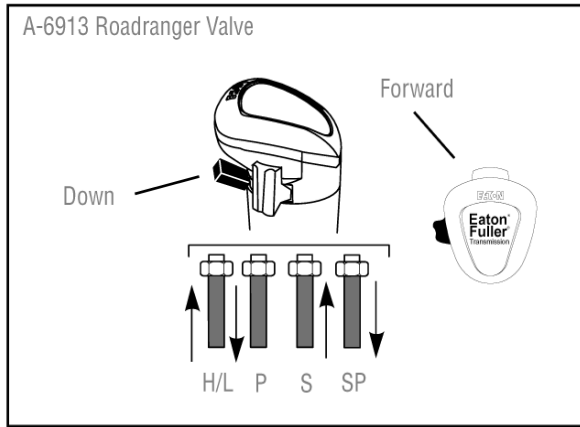

### Slave Valve Identification

A-4688 Valve (old)

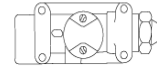

A-5000 Valve (current)

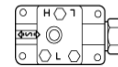

19470 Valve (obsolete)

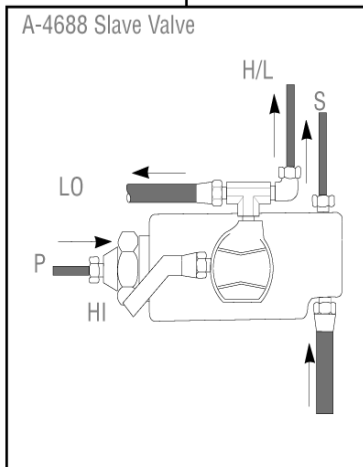
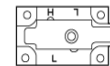

OR

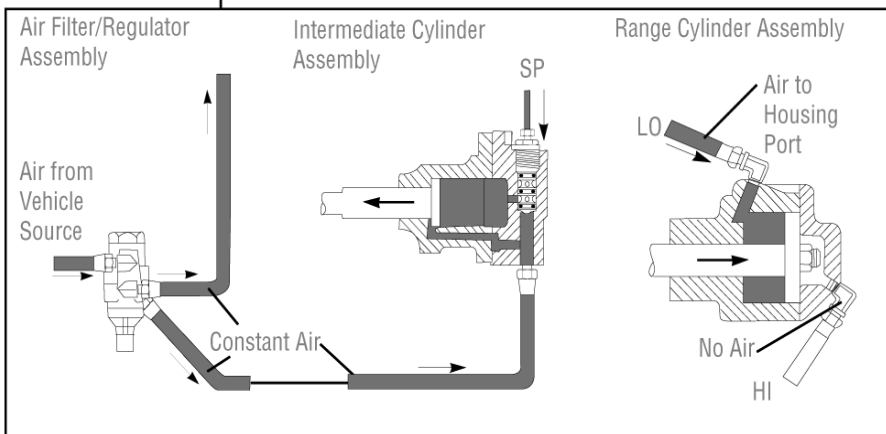
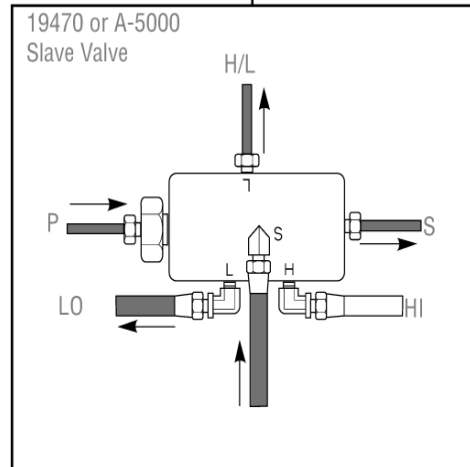

## Range—LO

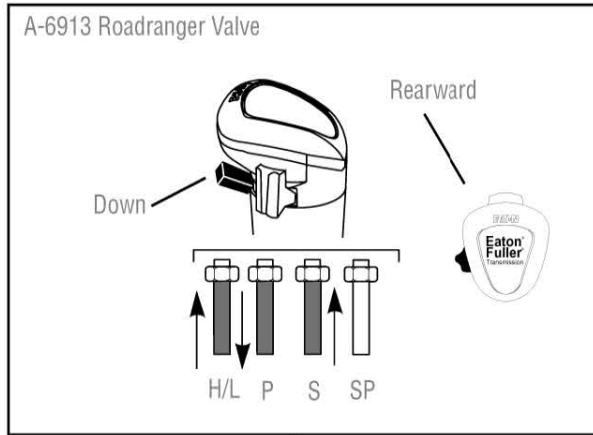

### Slave Valve Identification

A-4688 Valve (old)

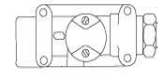

A-5000 Valve (current)

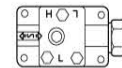

19470 Valve (obsolete)

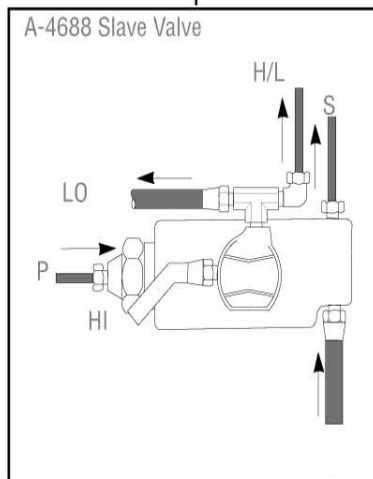
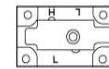

OR

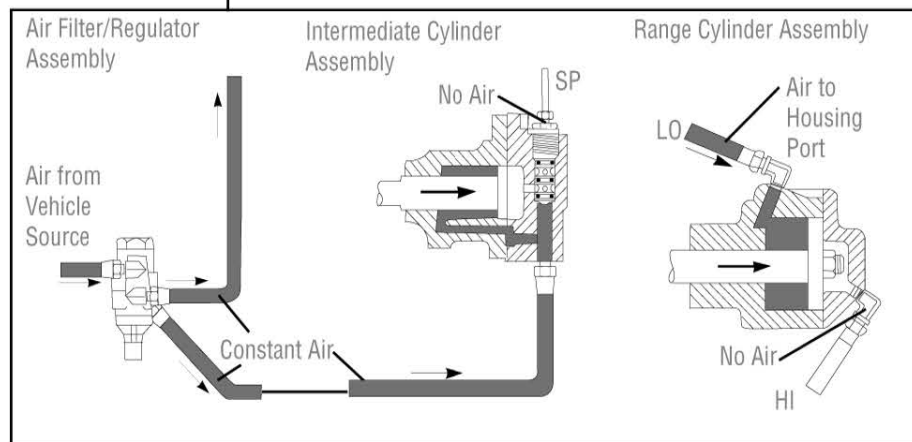
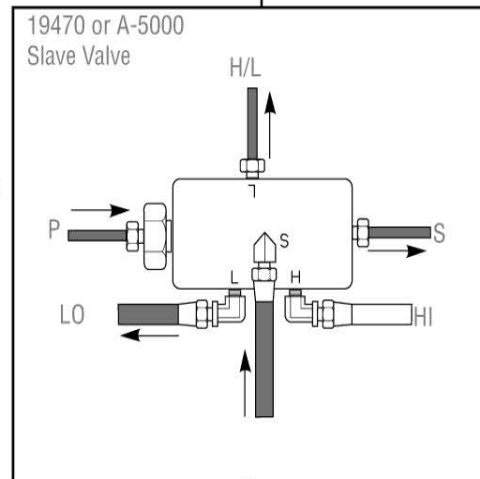

Operation

# Operation

## Range—HI

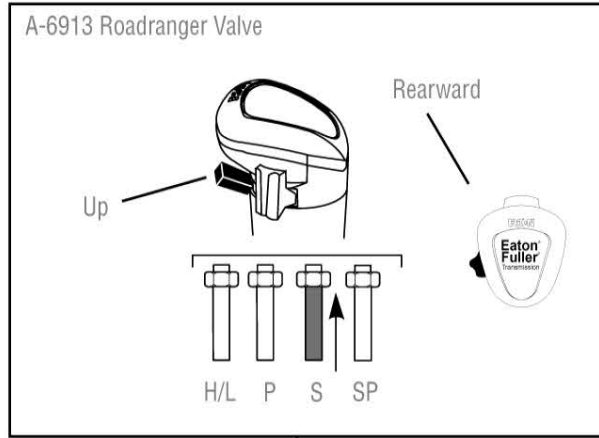

### Slave Valve Identification

A-4688 Valve (old)

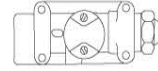

A-5000 Valve (current)

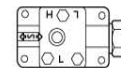

19470 Valve (obsolete)

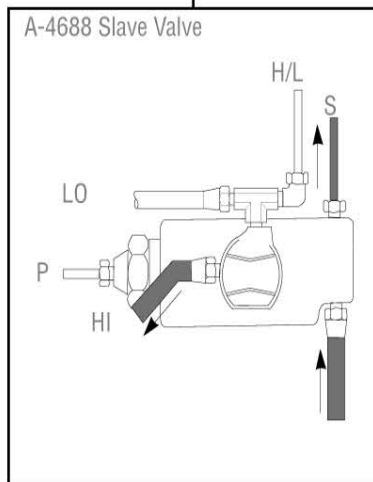
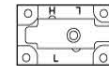

OR

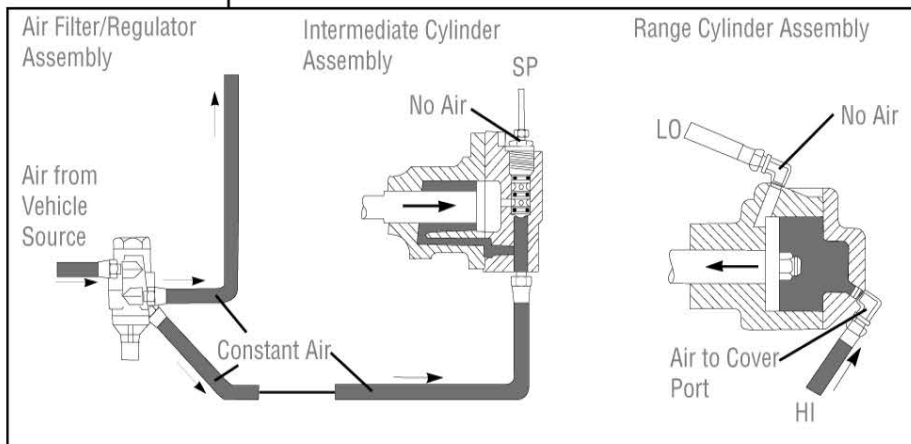
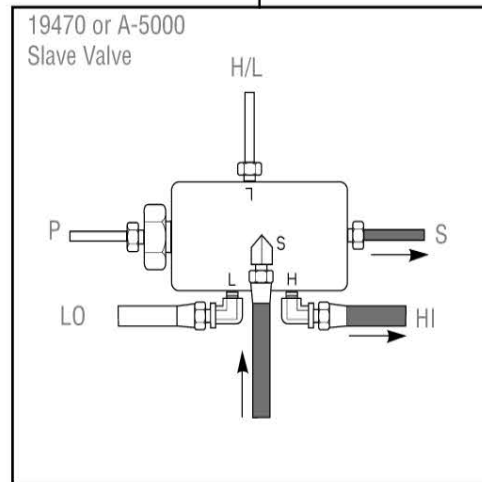

## 7608LL with A-6915 Roadranger Valve

This system consists of a A-6915 Roadranger valve and a deep reduction cylinder in addition to the range cylinder. The deep reduction cylinder shifts the transmission between deep reduction and LO range. The range cylinder shifts the transmission between LO and HI range.

Air is supplied to the system at the air supply port (1) by the vehicle's air system. The air filter (2) removes foreign matter from the air then allows it to pass through the air regulator (3) where the pressure is adjusted for 58 to 63 PSI (4.0 daN/cm<sup>2</sup>). From there the air passes through the supply air hose (4) to the slave valve supply port (5) through the supply air line to the Roadranger valve(6).

Depending upon the position of the splitter button (7), if air passes through the air line (8) connected to the deep reduction cylinder top port (9) then the deep reduction gearing is engaged. If there is no air, the constant air from the air filter/regulator assembly (10) moves the piston forward to disengage deep reduction gearing.

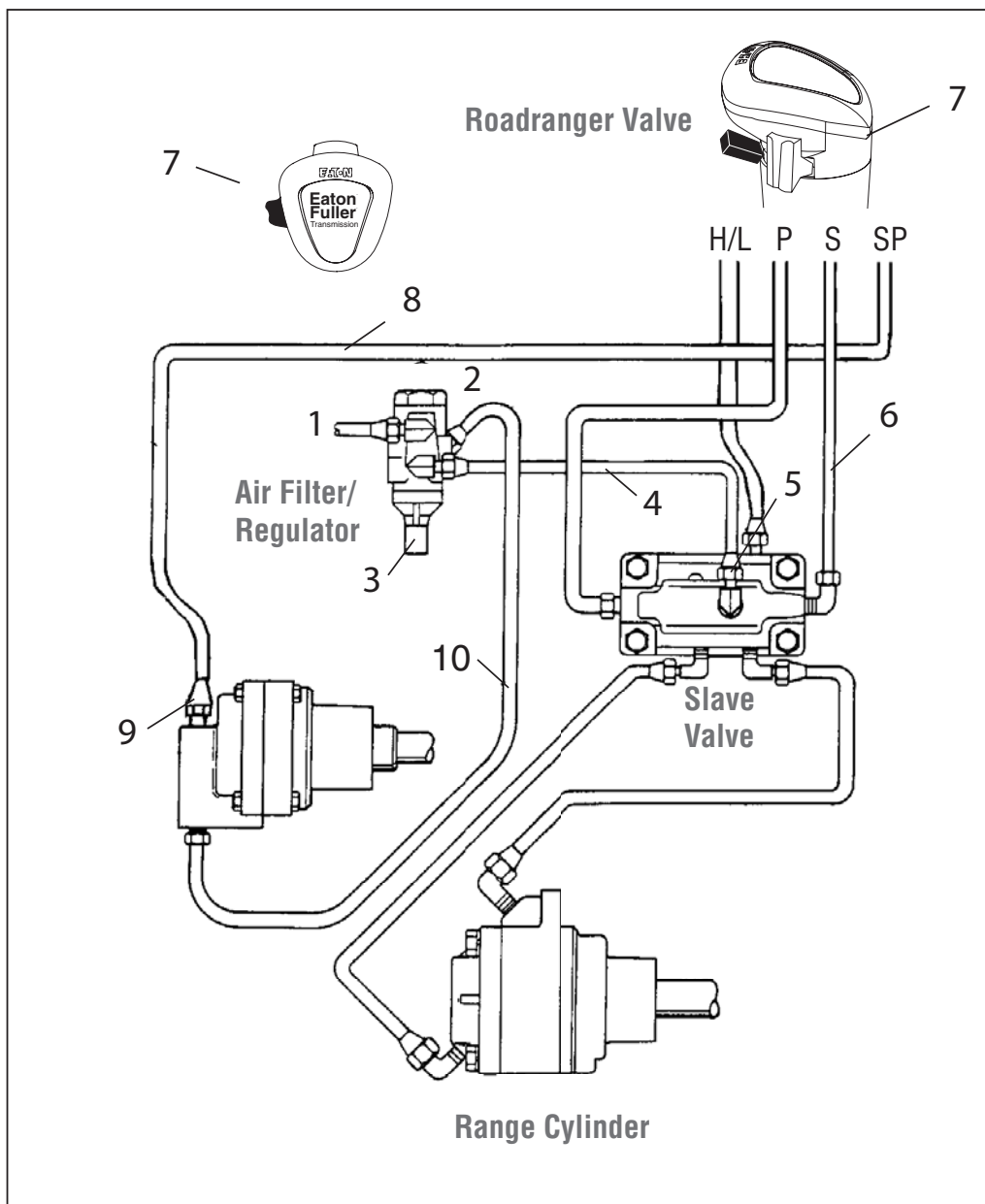

# Operation

## 7608LL Models

### Deep Reduction

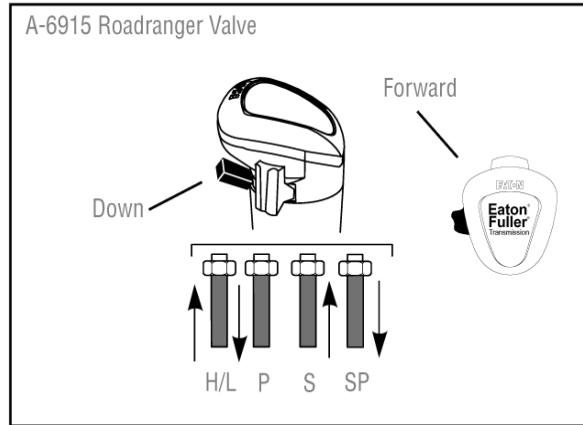

### Slave Valve Identification

A-5000 Valve (current)

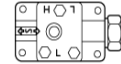

19470 Valve (obsolete)

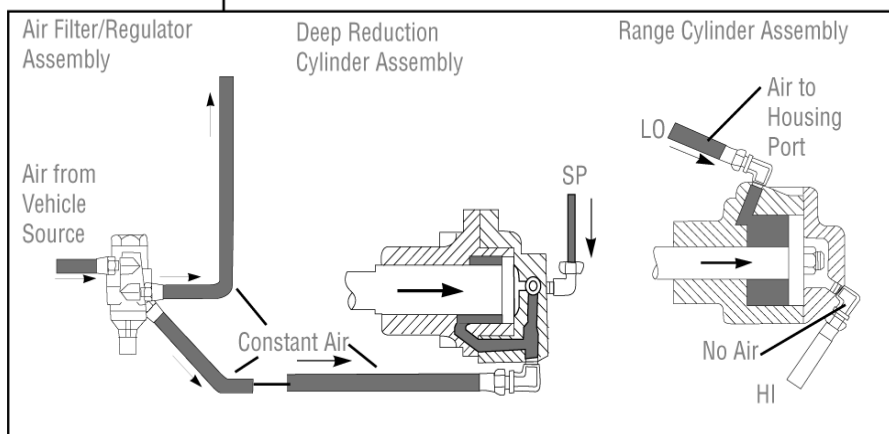
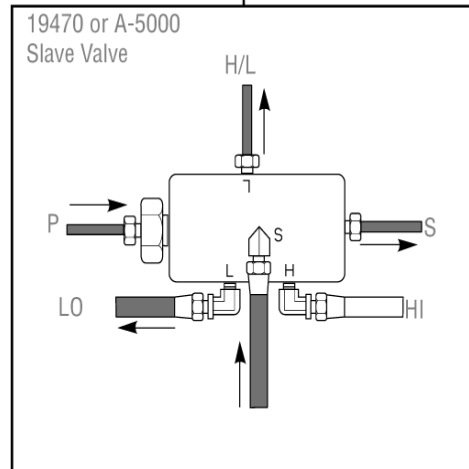
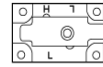

## Range—LO

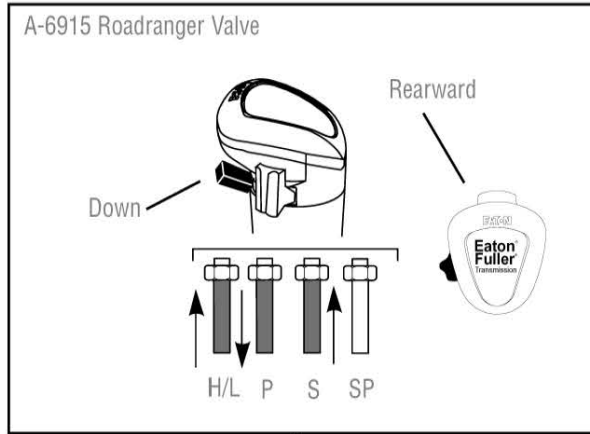

### Slave Valve Identification

A-5000 Valve (current)

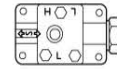

19470 Valve (obsolete)

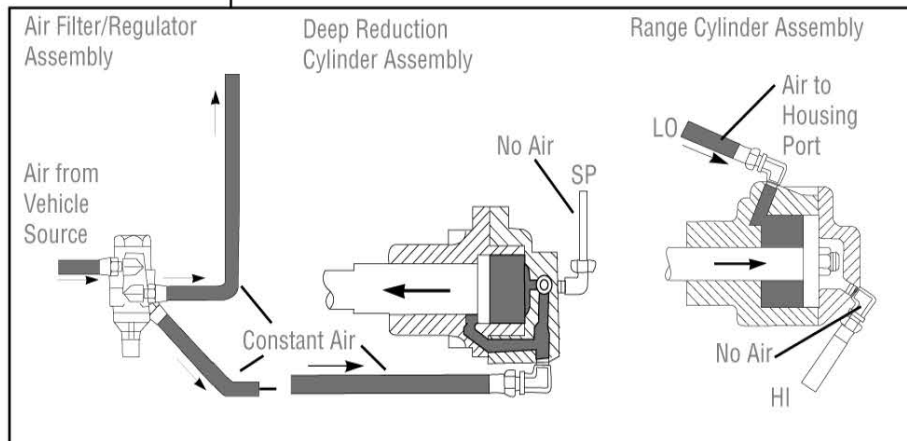
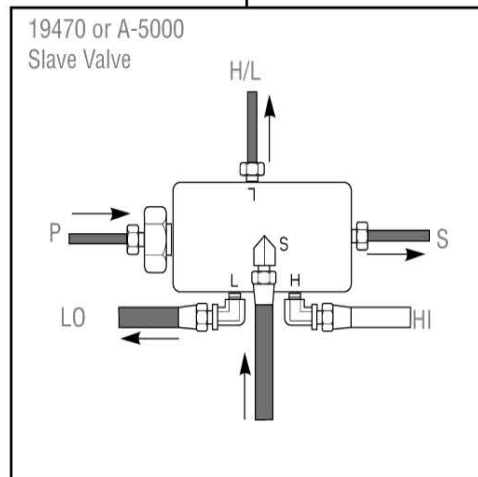
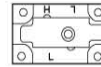

Operation

# Operation

Range—HI

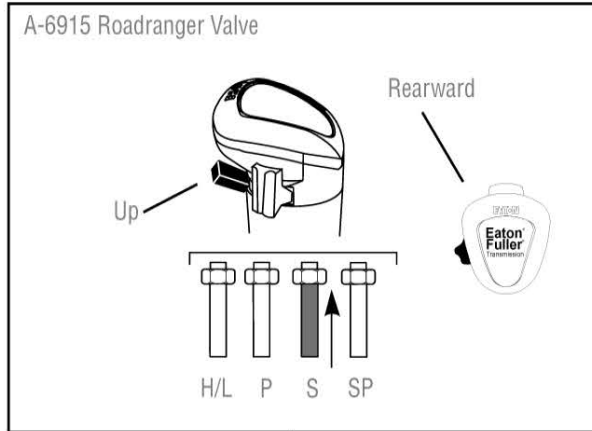

## Slave Valve Identification

A-5000 Valve (current)

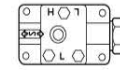

19470 Valve (obsolete)

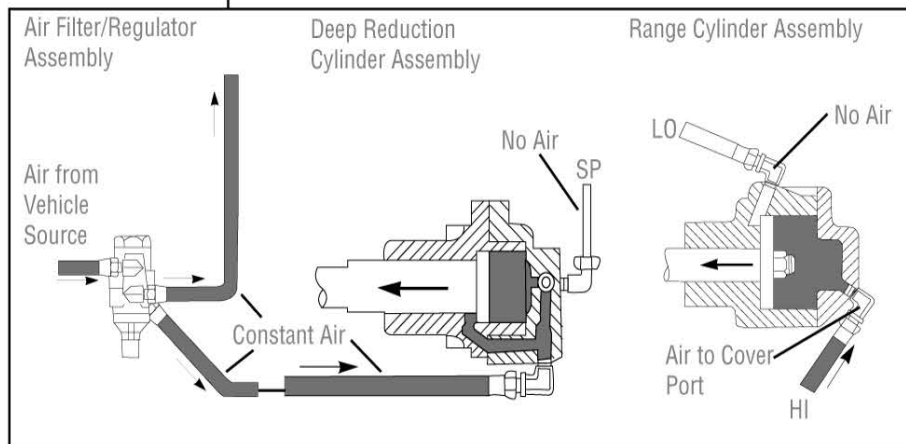
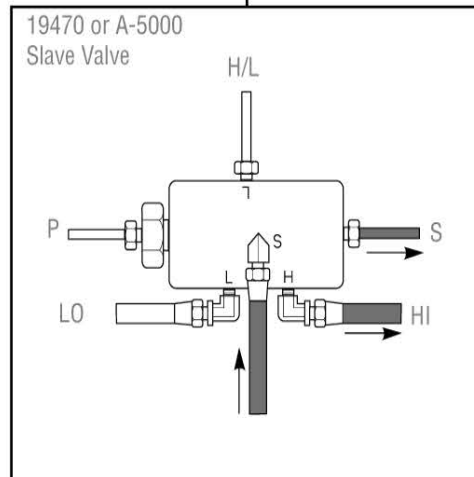
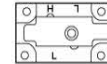

## RTLO-xx610 Speed Air System

This system consists of a A-6910 Roadranger valve, range actuator valve, a splitter shift cylinder and a range cylinder. The splitter cylinder shifts the transmission between odd and even numbered gear positions. The range cylinder shifts the transmission between LO and HI range.

Air is supplied to the system at the air supply port (1) by the vehicle's air system. The air filter (2) removes foreign matter from the air then allows it to pass through the air regulator where the pressure is adjusted for 58 to 63 PSI (4.0 daN/cm<sup>2</sup>). From there the air passes through the supply air hose (3) to the range actuator valve supply port through the supply air line (4) to the Roadranger valve.

Depending upon the position of the splitter button (5), if air passes through the air line (6) connected to the splitter cylinder top port (7) then the even numbered gear positions are engaged. If there is no air, the constant air from the air filter/regulator assembly (8) moves the splitter piston rearward to engage odd numbered gear positions.

The transmission shift lever automatically activates LO and HI range depending on gear position.

## Latest Design

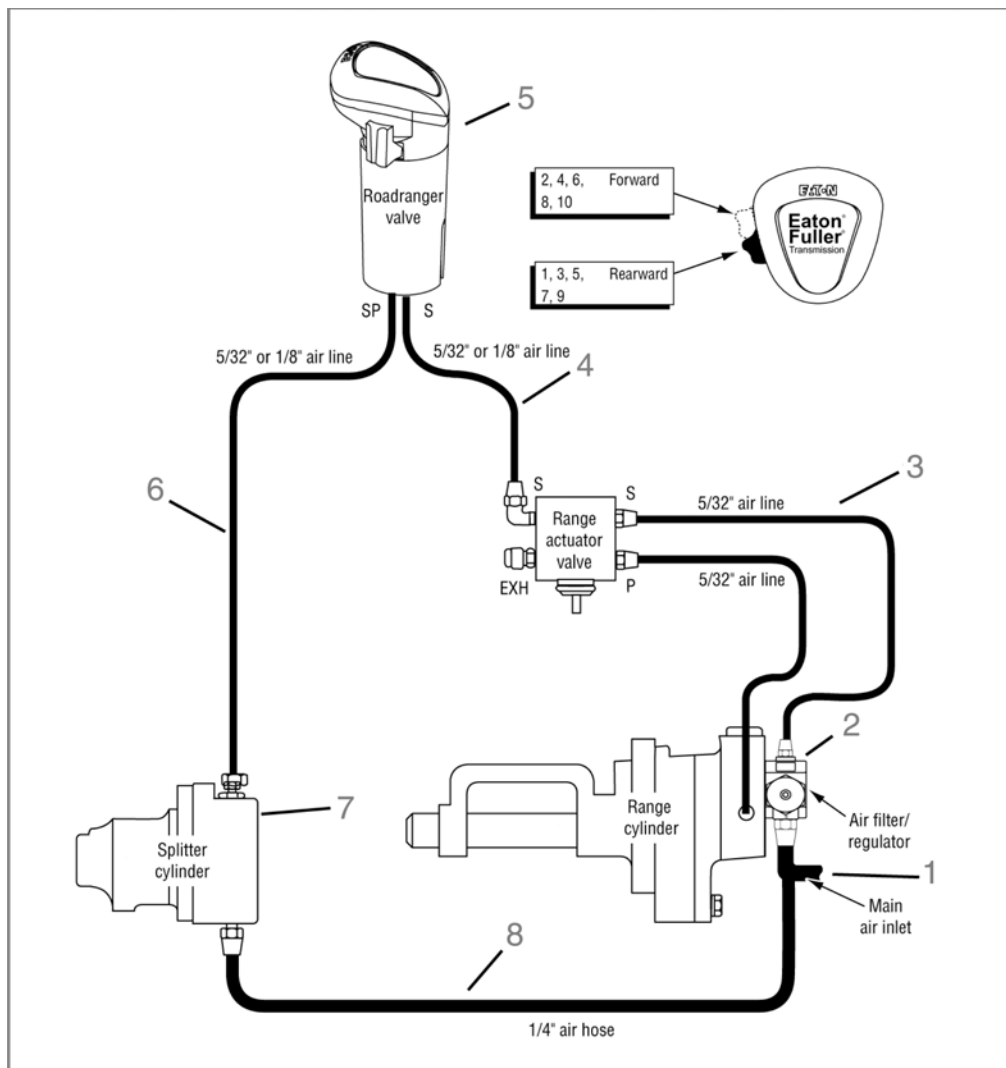

Operation



# Operation

## Old Design

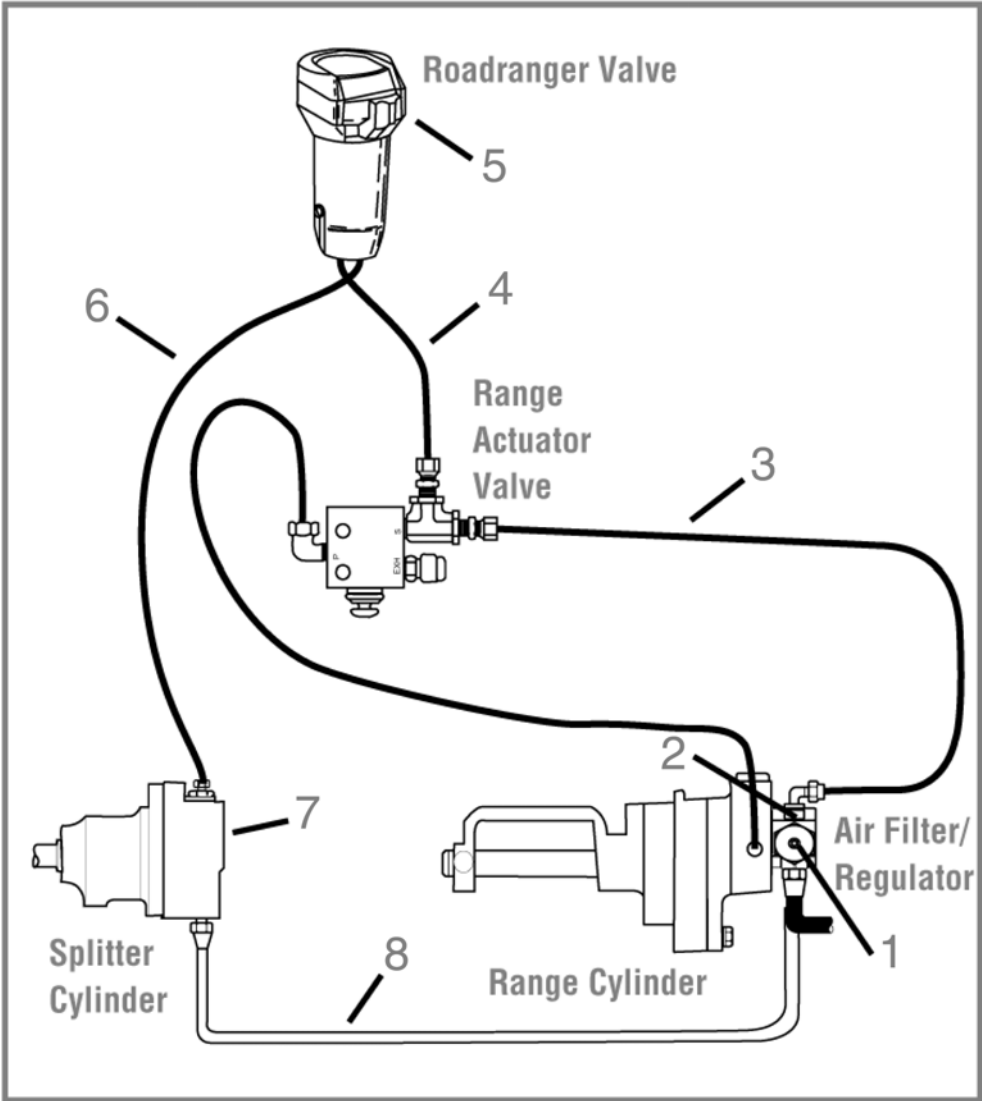

RTLO-xxx610 Models

LO Range—1, 3, 5 Gears

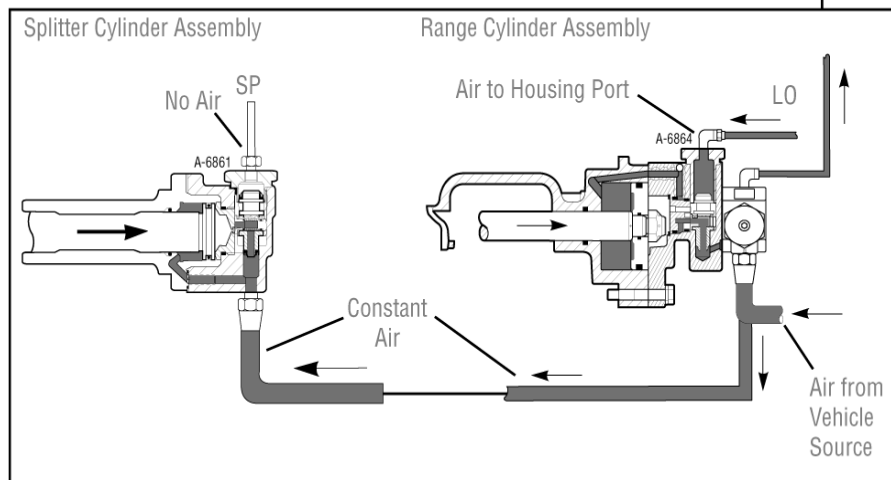
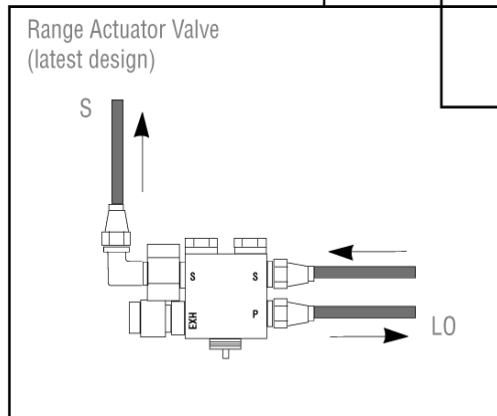
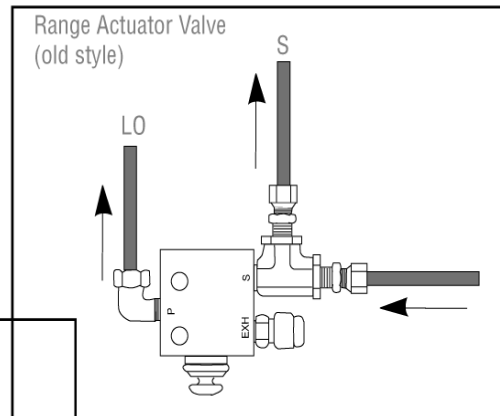
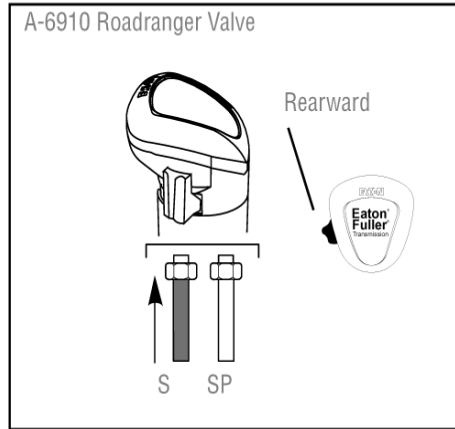

Operation

# Operation

## LO Range—2, 4, 6 Gears

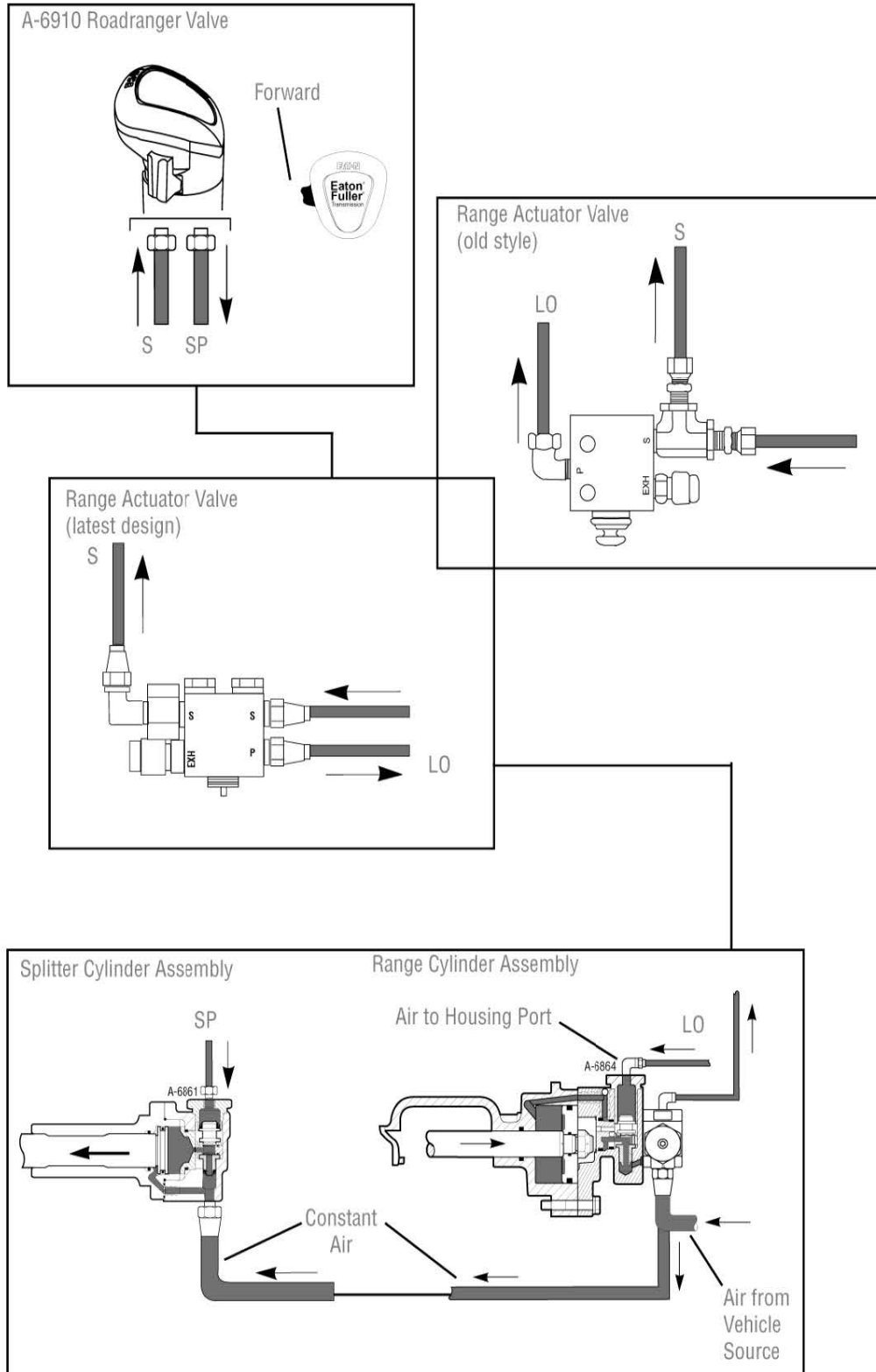

HI Range—7, 9 Gears

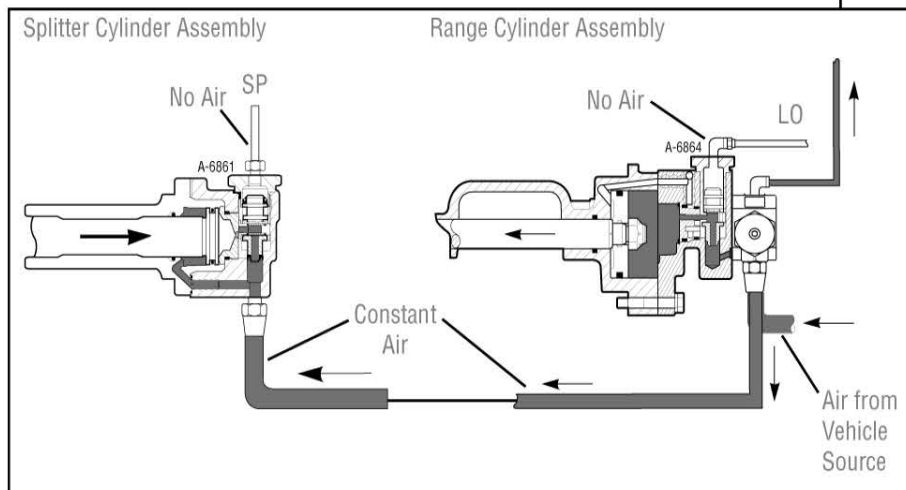
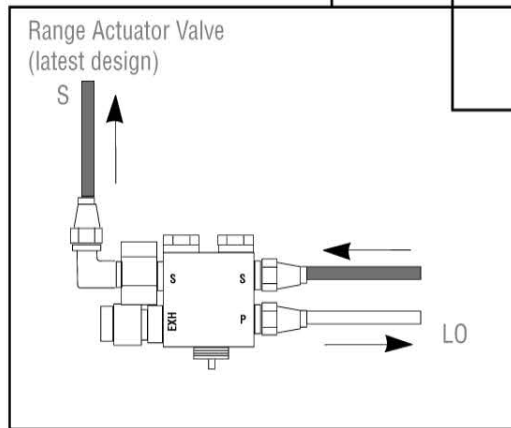
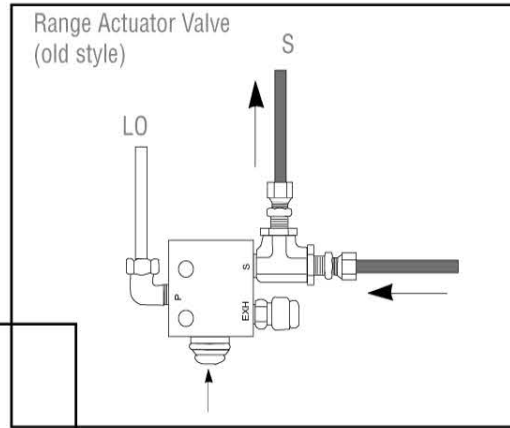
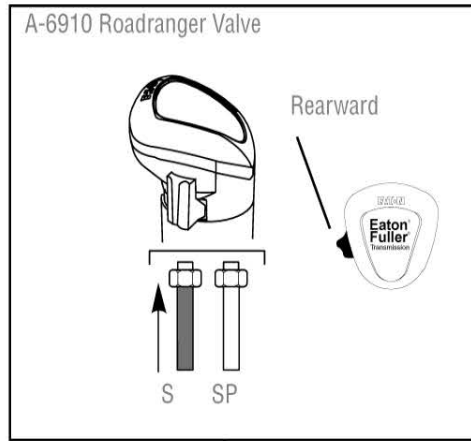

Operation

# Operation

## HI Range—8, 10 Gears

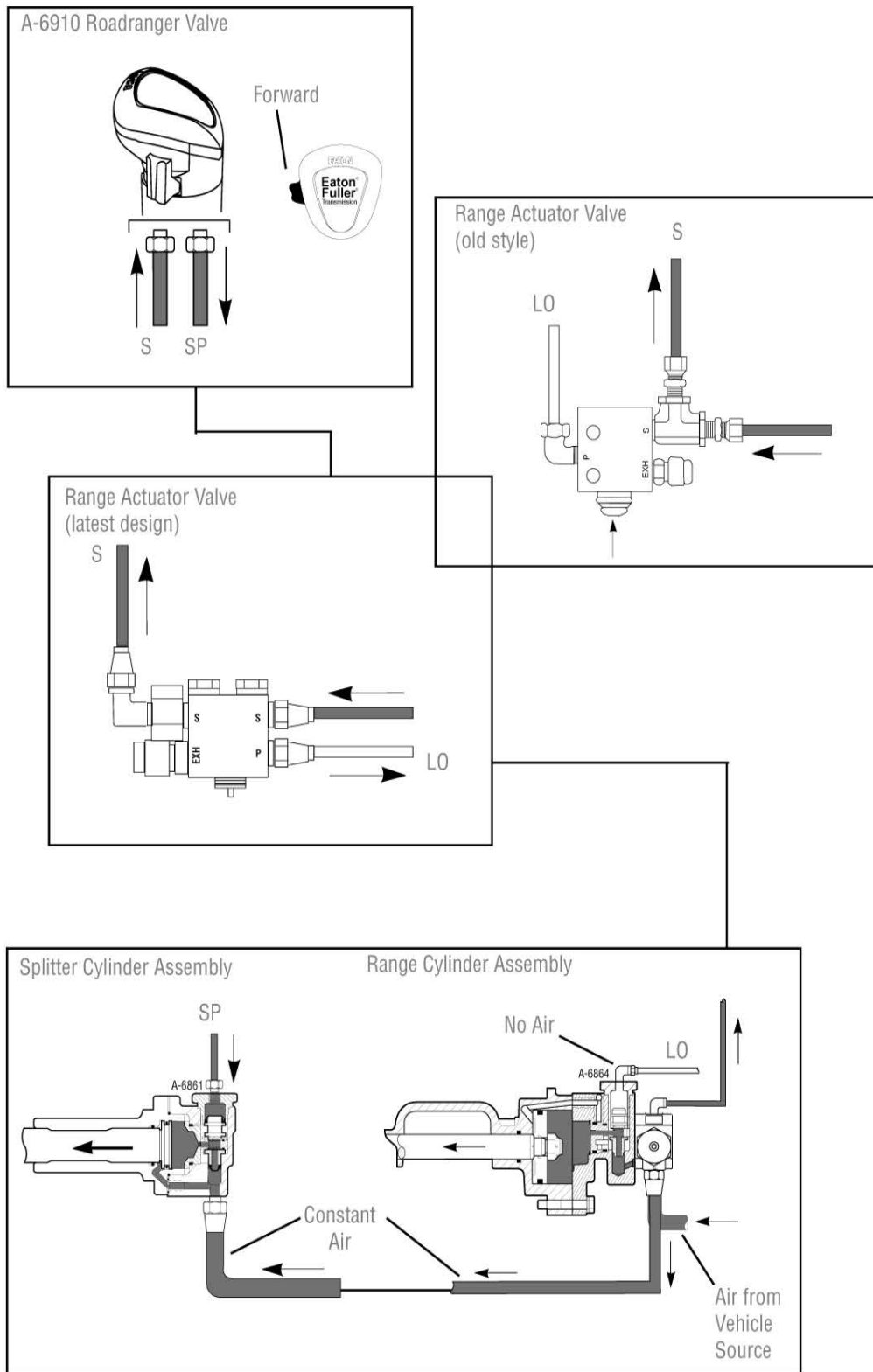

## RTL-xx710 Speed Models

This system consists of a A-6910 Roadranger valve, range actuator valve, a splitter shift cylinder and a range cylinder. The splitter cylinder shifts the transmission between odd and even numbered gear positions. The range cylinder shifts the transmission between LO and HI range.

Air is supplied to the system at the air supply port (1) by the vehicle's air system. The air filter (2) removes foreign matter from the air then allows it to pass through the air regulator where the pressure is adjusted for 58 to 63 PSI (4.0 daN/cm<sup>2</sup>). From there the air passes through the supply air hose (3) to the range actuator valve supply port through the supply air line (4) to the Roadranger valve.

Depending upon the position of the splitter button (5), if air passes through the air line (6) connected to the splitter cylinder top port (7) then the even numbered gear positions are engaged. If there is no air, the constant air from the air filter/regulator assembly (8) moves the splitter piston forward to engage odd numbered gear positions.

The transmission shift lever automatical activates LO and HI range depending on gear position.

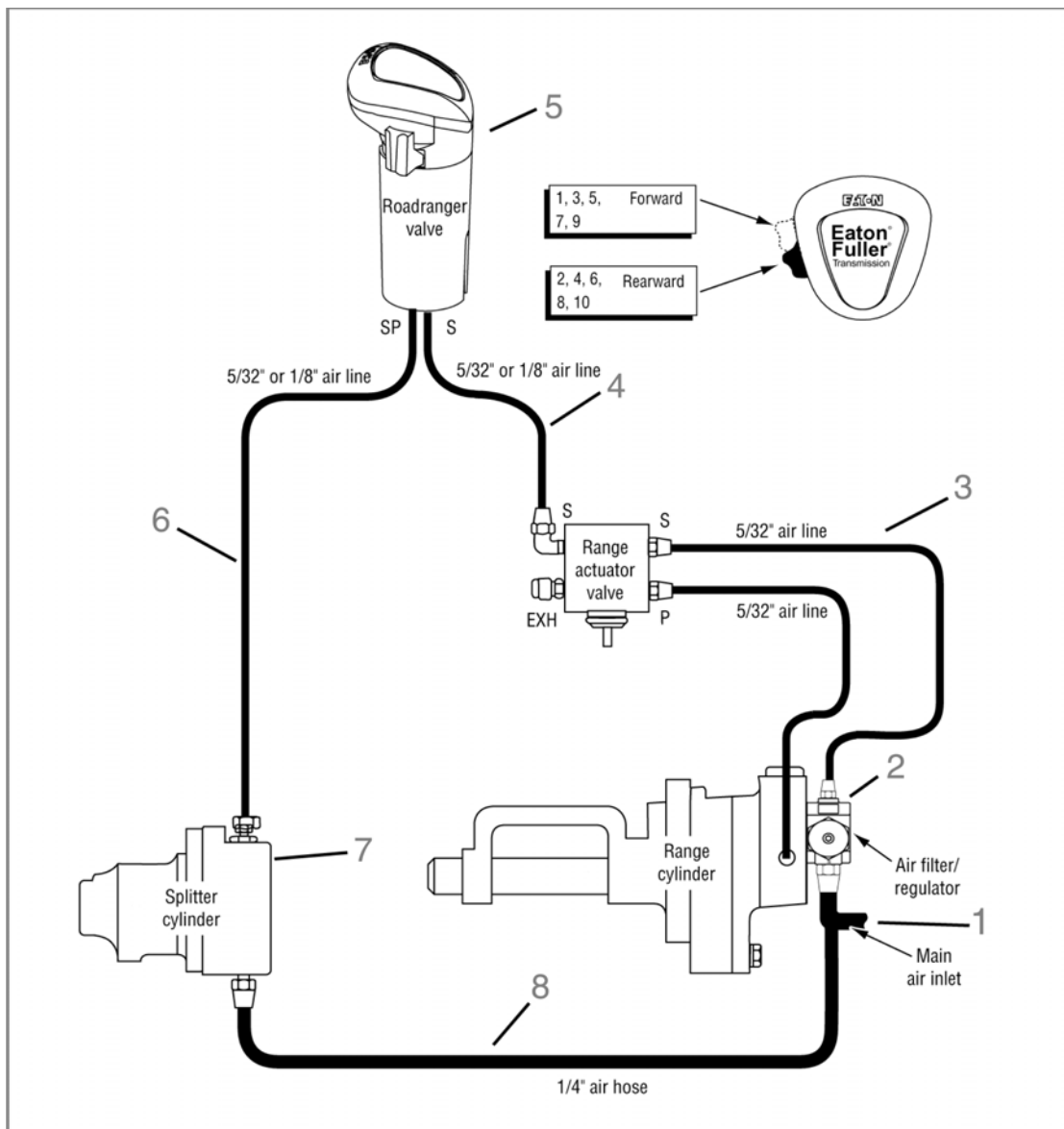

Operation

# Operation

## RTL-xx710 Models

LO Range—1, 3, 5 Gears

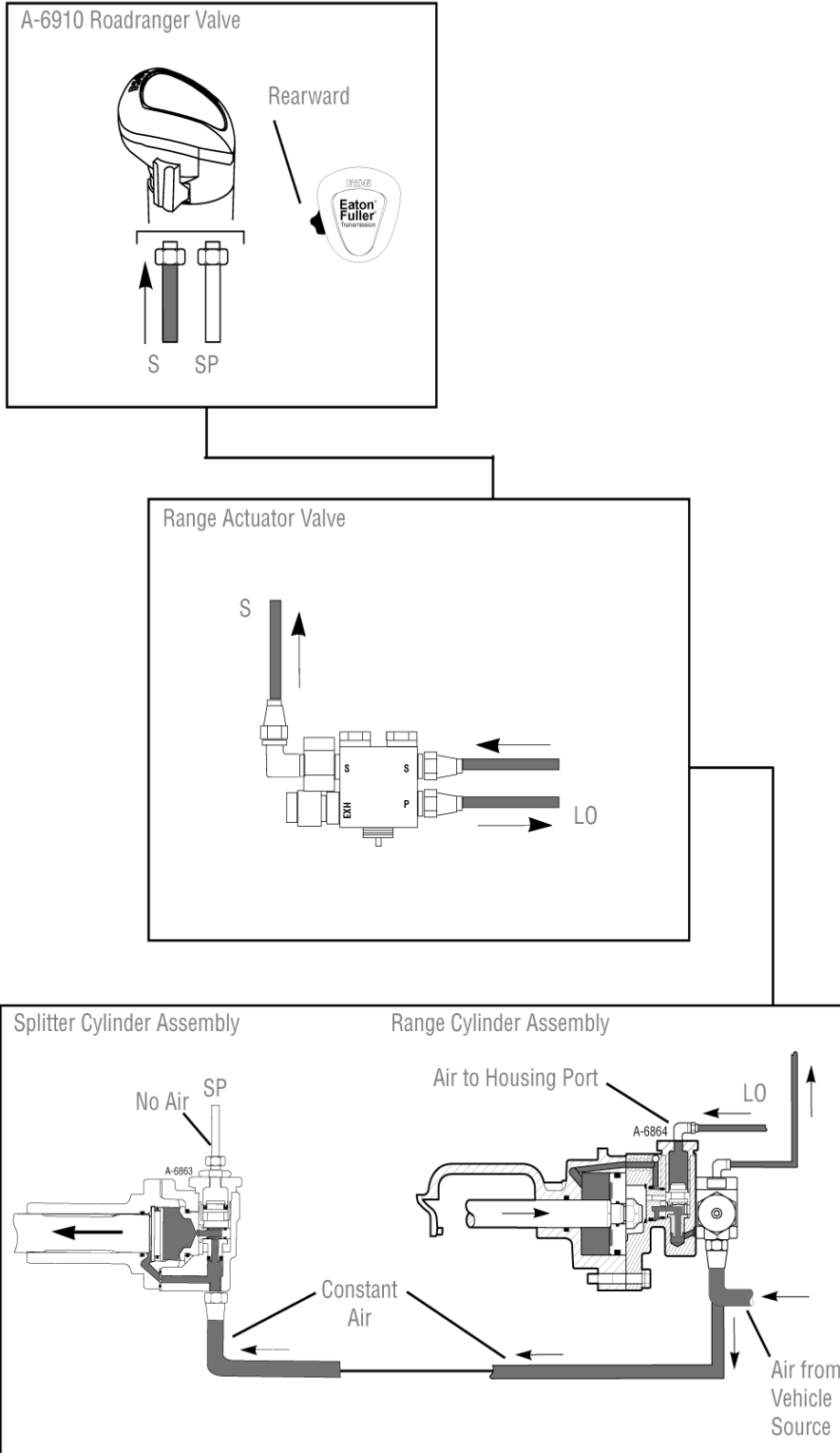

LO Range— 2, 4, 6 Gears

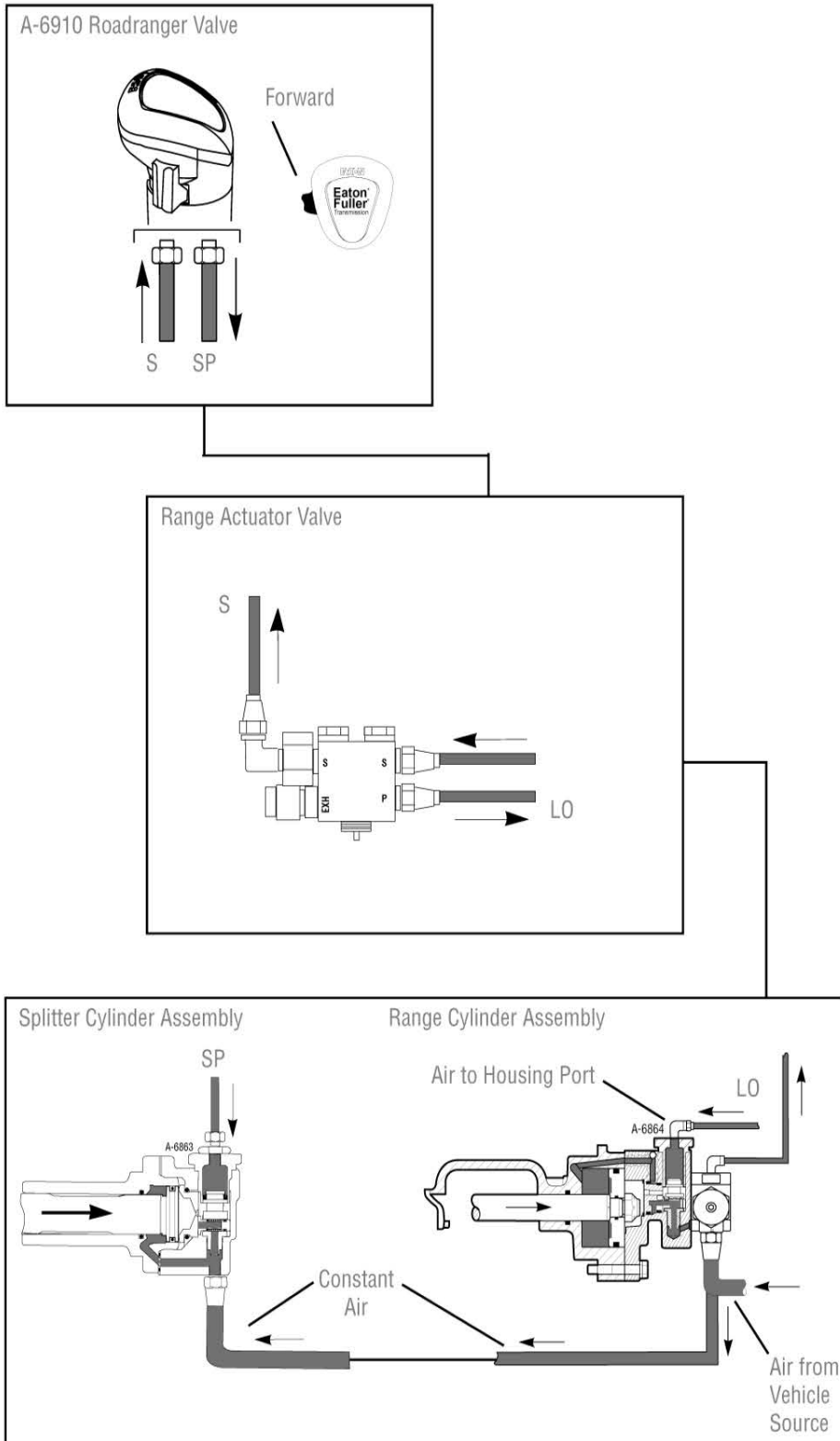

Operation



# Operation

## HI Range—7, 9 Gears

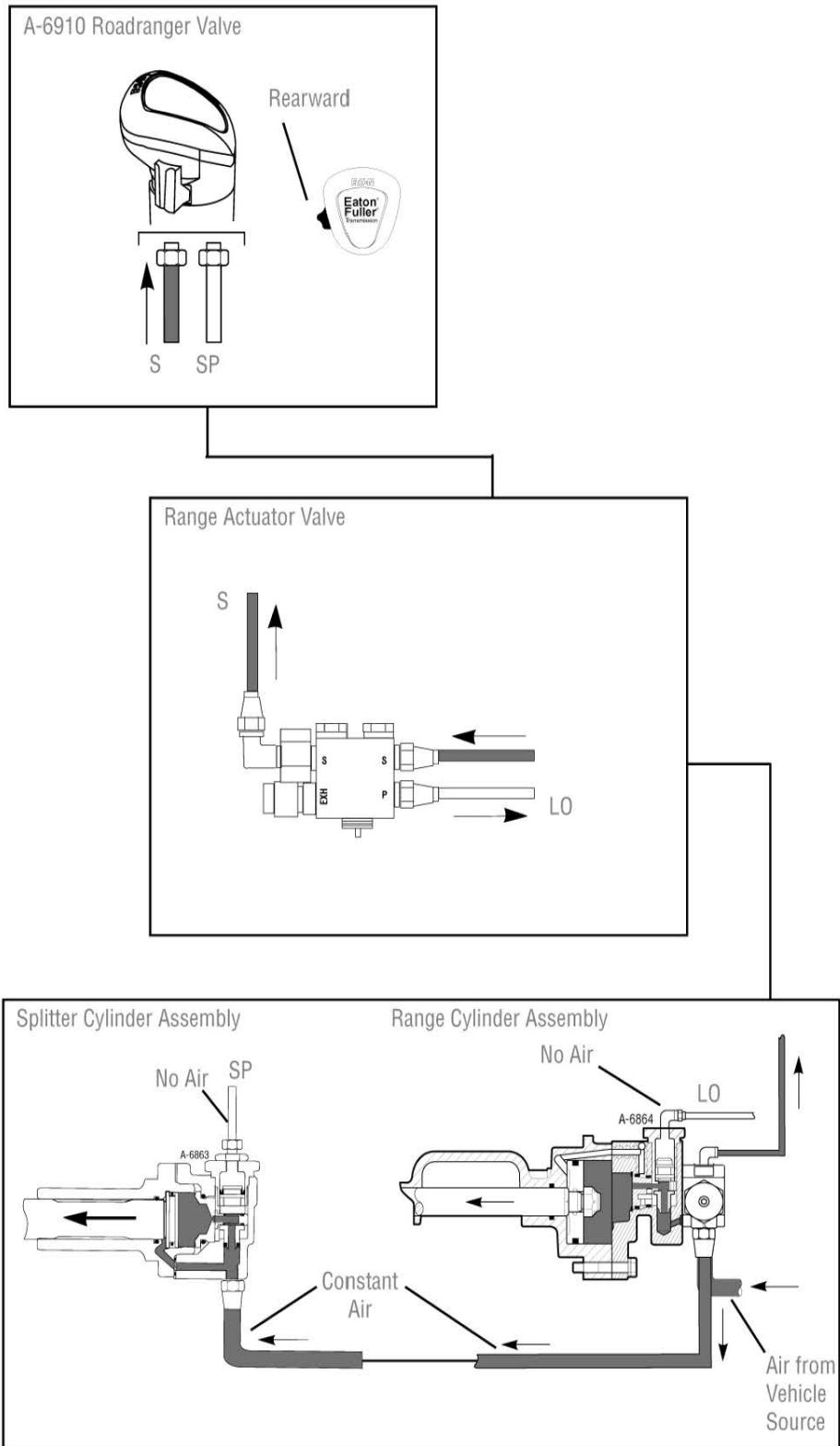

HI Range— 8, 10 Gears

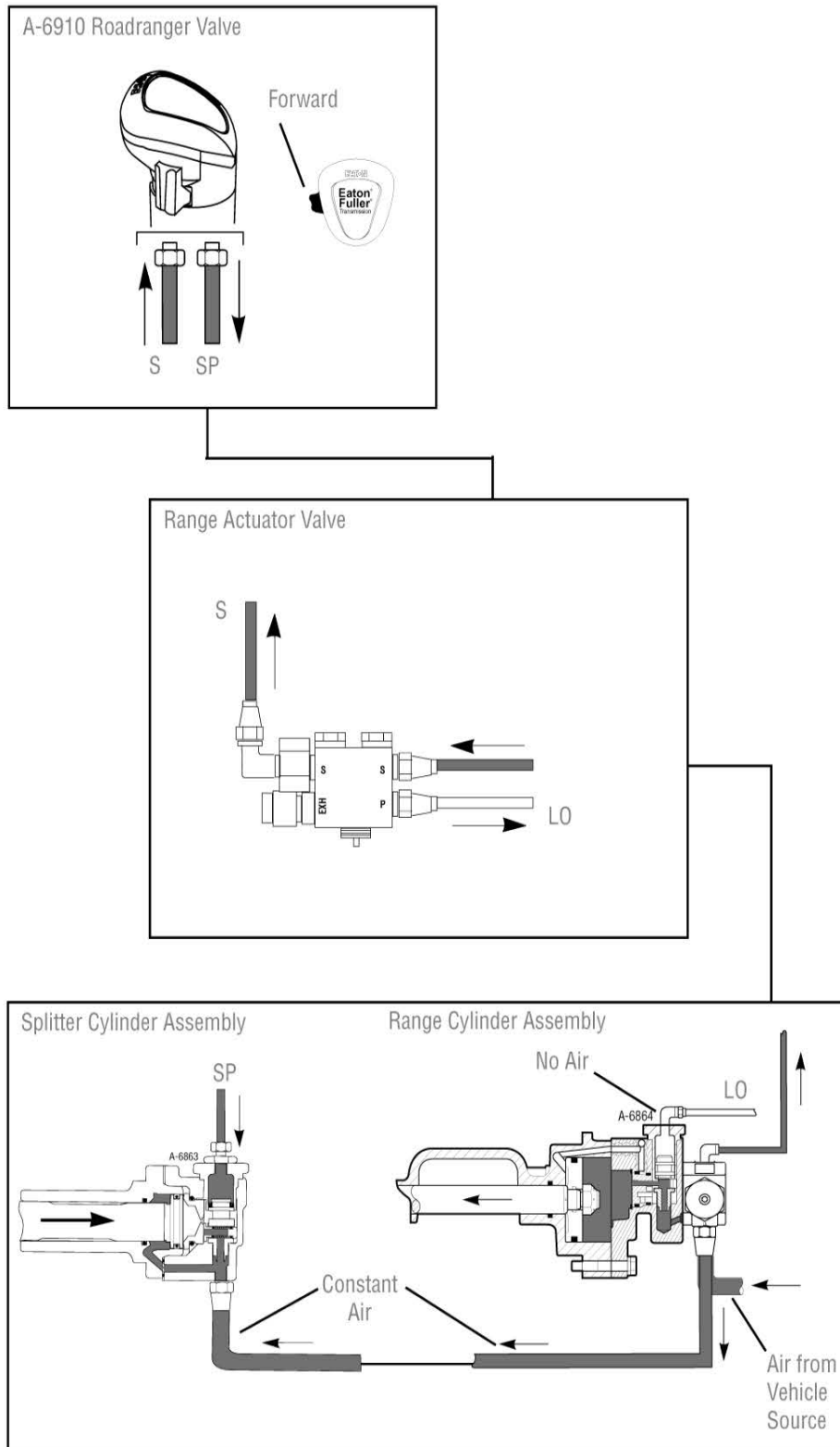

Operation

# Operation

## AT-1202 Auxillary Transmission (with 2 Position Shift Valve)

### *LO Range*

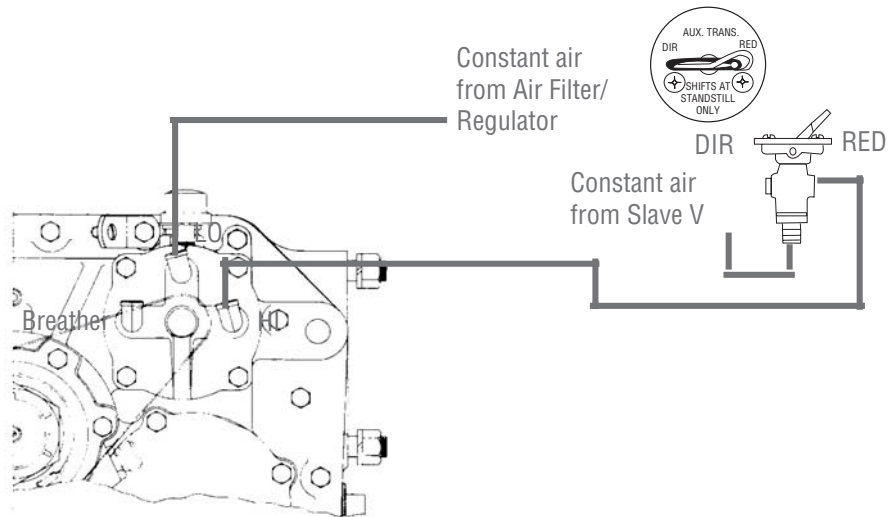

When the lever is moved to the Reduction (RED) position, air is shut off to piston rear side. The constant air moves the range piston rearward and shifts the auxiliary transmission into Reduction.

### *High Range*

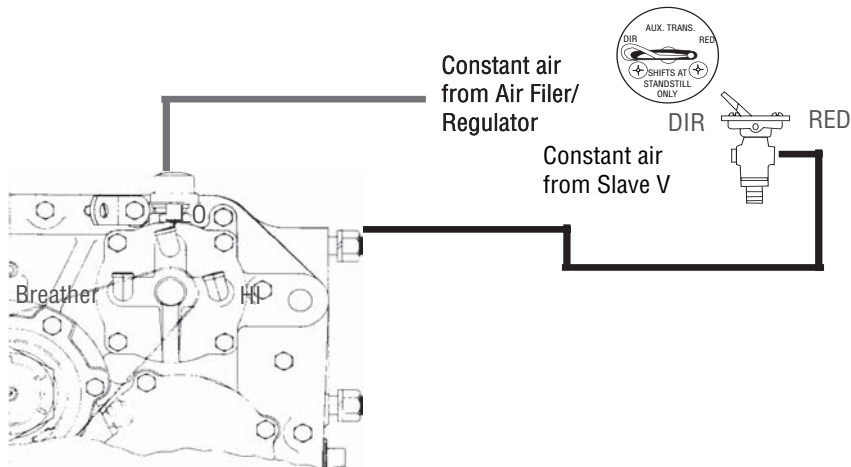

When the lever is moved to the direct (DIR) position, the valve allows air to flow through to the piston rear side. The constant air moves the range piston forward and shifts the auxiliary transmission into Direct.

### AT-1202 Auxiliary Housing (3 Position Valve)

**Neutral**

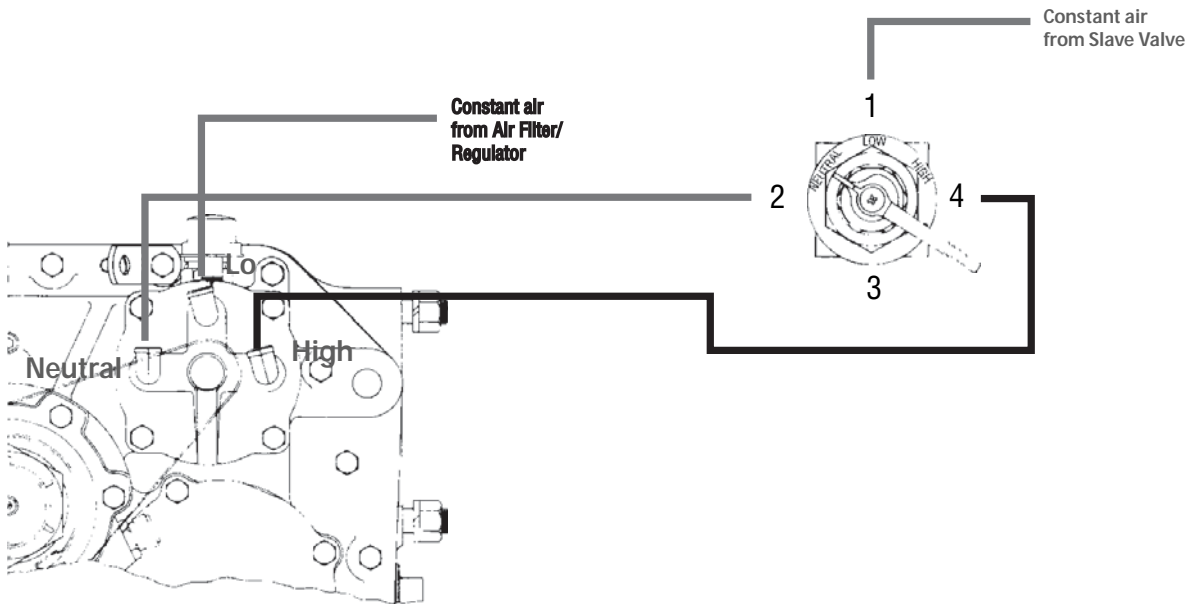

The valve allows air to pass from #1 to #2 placing the auxiliary transmission in neutral.

#4 is connected to #3 to exhaust the air.

**Reduction**

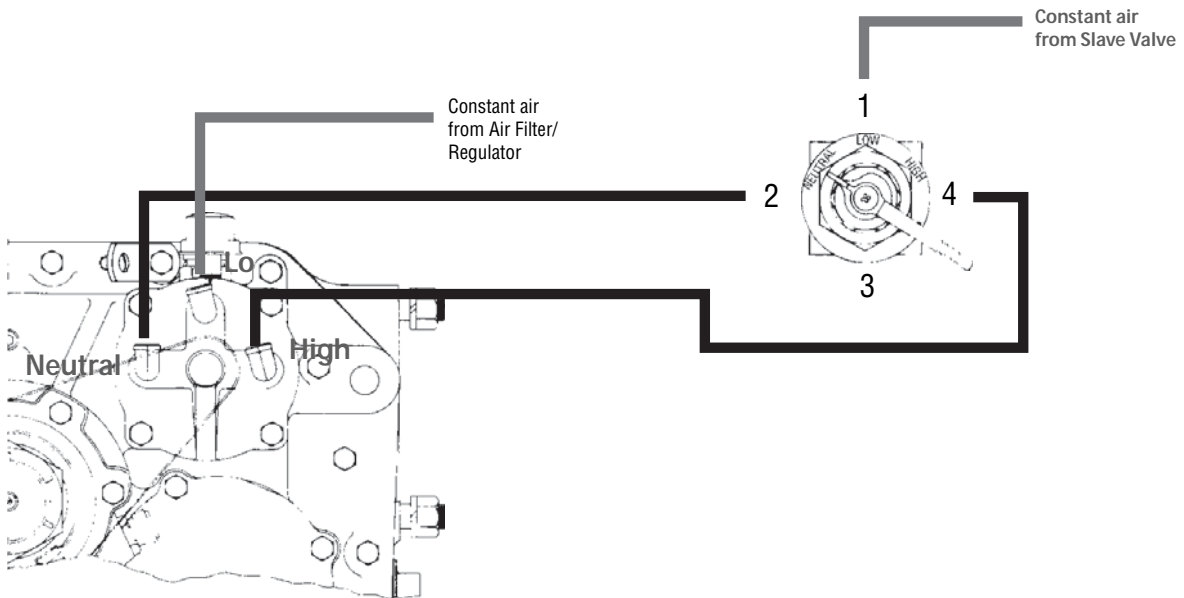

Operation

# Operation

---

When the switch is moved to the LOW position, the valve closes and stops the air at #1 placing the auxiliary transmission in LO.

## **Direct**

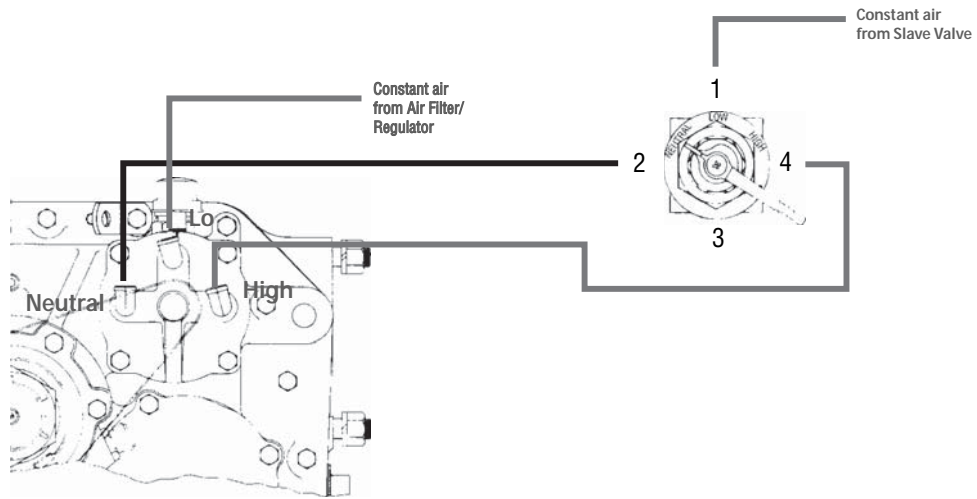

When the switch is moved to the HIGH position, the valve opens and allows the air from #1 to pass to #4, placing the auxiliary transmission in HI.

#2 is connected to #3 to exhaust the air.

## A-4740 Air Filter/Regulator Assembly

The air filter removes foreign matter from the air then allows it to pass through the air regulator where the pressure is adjusted to 58 to 63 PSI. The output air pressure will not be in range if the truck's air pressure is incorrect.

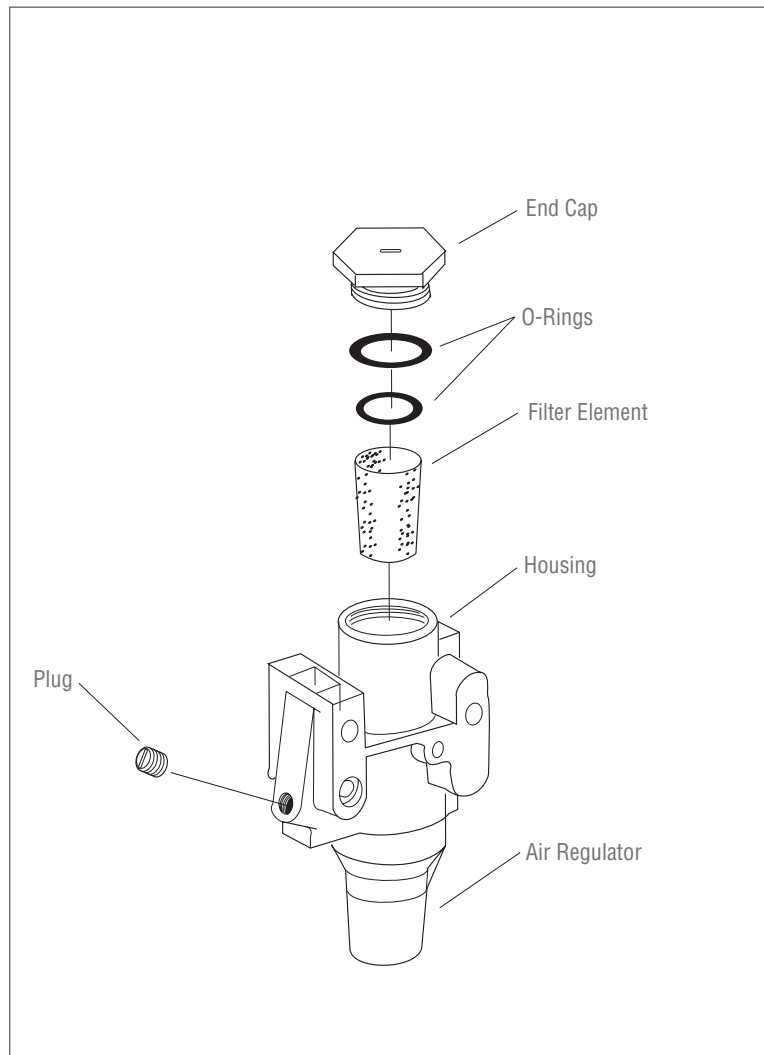

# System Components

## A-5161/A-5454 Air Filter/Regulator Assembly

The air filter removes foreign matter from the air then allows it to pass through the air regulator where the pressure is adjusted to 58 to 63 PSI. The output air pressure will not be in range if the truck's air pressure is incorrect.

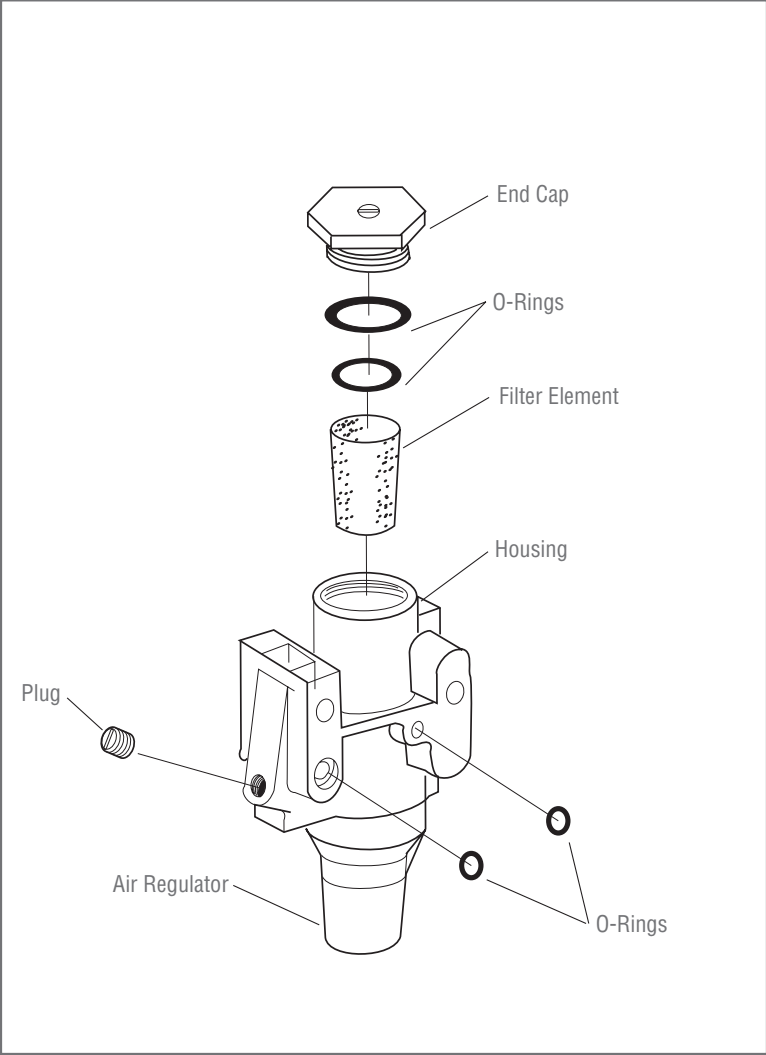

## A-3546 Range Valve

Constant air pressure is supplied from the slave valve to the Range valve inlet or "S" port (1).

In LO range (range knob down (2), air passes through the valve and out the range valve outlet or "P" port (3). This air returns to the slave valve end port or "P" port depending on the slave valve used.

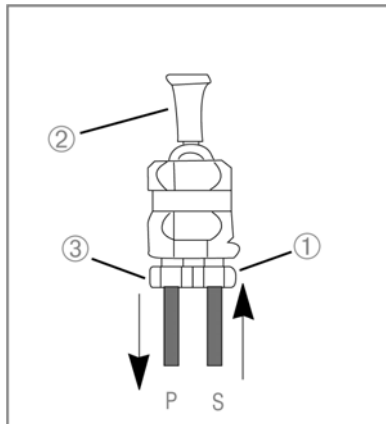

In HI range (range knob up (2) the knob prevents the air from passing through the Range valve. Air pressure which was in the outlet line (3) is exhausted out the bottom.

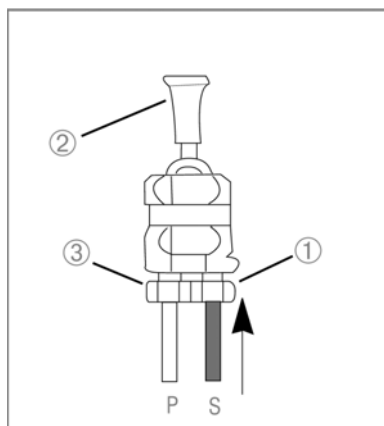



# System Components

---

## A-5010/A-6909 Roadranger Valve

Constant air pressure is supplied from the slave valve to the Roadranger valve inlet or "S" port (1).

In LO range (range lever down (2), air passes through the lever and out the Roadranger valve outlet or "P" port (3). This air returns to the slave valve end port or "P" port depending on the slave valve used.

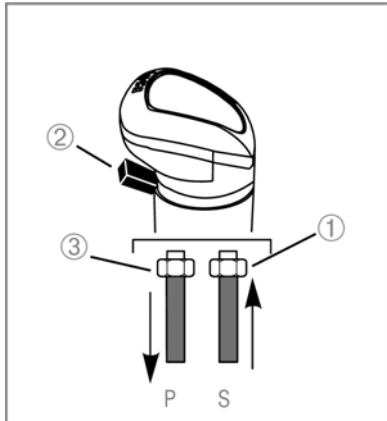

In HI range (range lever up (2) the lever prevents the air from passing through the Roadranger valve. Air pressure which was in the outlet line (3) is exhausted out the Roadranger valve "E" port.

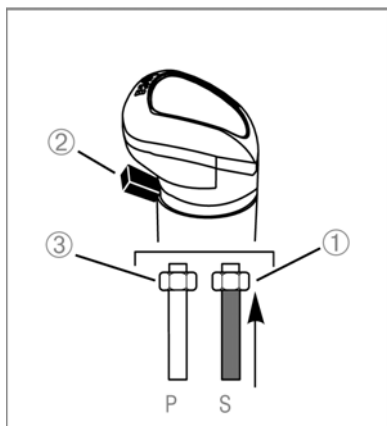

## 14651 Reduction Valve (Dash-Mounted)

With the deep reduction lever in the "OUT" position (1), the valve is opened (2) and air is supplied to the deep reduction cylinder cover center port, moving the reduction piston forward to disengage deep reduction gearing.

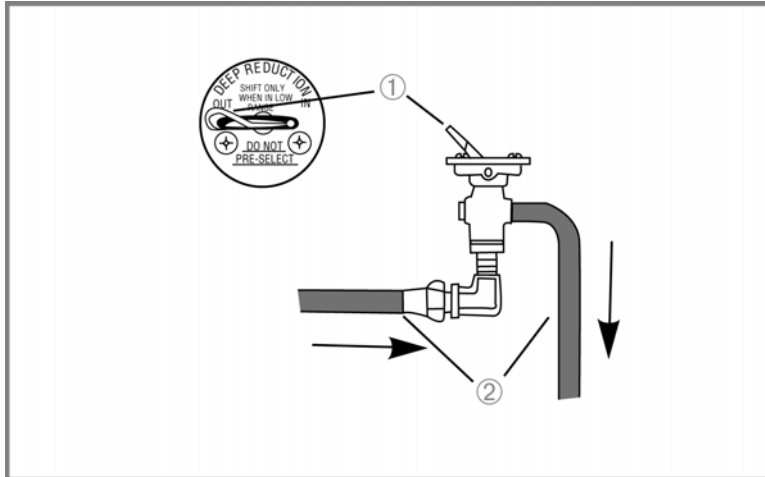

With the deep reduction lever in the "IN" position (1), the valve is closed (2) and no air is supplied to the deep reduction cylinder cover center port. The constant air from the air filter/regulator assembly moves the reduction piston rearward to engage deep reduction gearing.

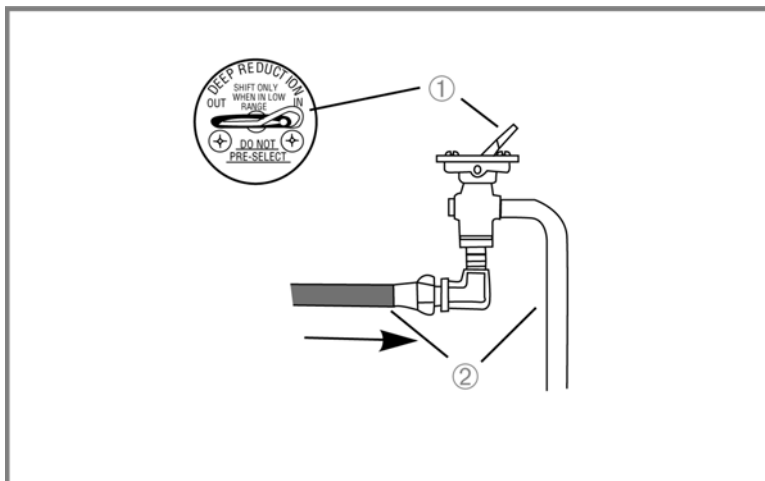

# System Components

---

## A-5015/A-6915 Roadranger Valve

Constant air pressure is supplied from the slave valve to the Roadranger valve “S” port and “H/L” port (for deep reduction and LO range (1)).

For deep reduction (range lever down (2), deep reduction button forward (3), air flows out of the roadranger valve “P” port and “SP” port (4).

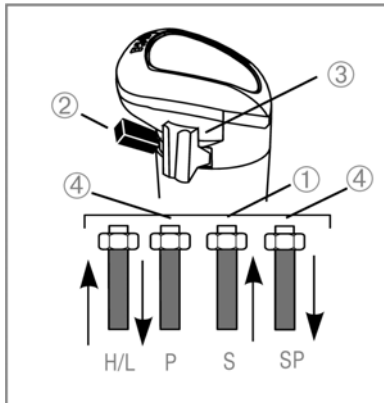

For LO range (range lever down (2), deep reduction button rearward (3), air flows out of the roadranger valve “P” port (4).

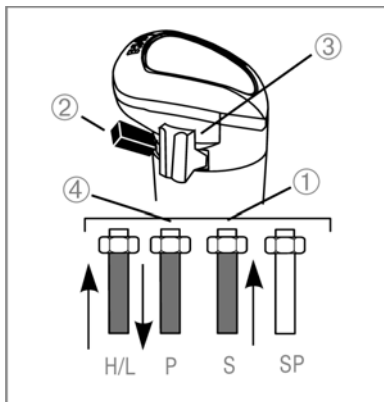

For HI range (range lever up (2), deep reduction button rearward (3), the lever stops the air from passing through the Roadranger valve. Air pressure which was in the outlet line is exhausted out the Roadranger valve bottom.

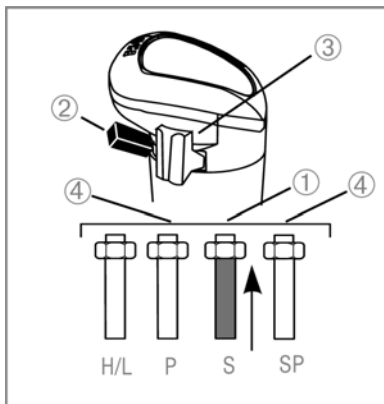

The Roadranger valve mechanical interlock prevents forward movement of the deep reduction button while in HI range.

## Two Position Selector Valve

Constant air pressure is supplied from the slave valve to the A-3546 range valve “S” port (1).

For LO range (range knob down (2), selector valve button in the “DIR” position (3), air flows out of the range valve “P” port (4).

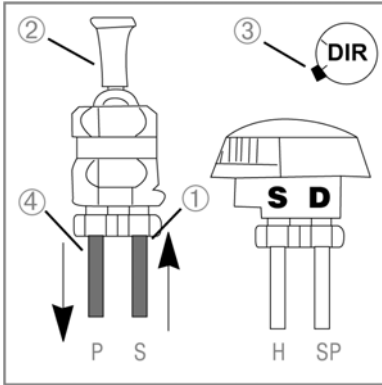

For direct operation (range knob up (2), selector valve button in the “DIR” position (3), the knob prevents the air from passing through the selector valve: air now flows through the “H” port and into the selector valve (5).

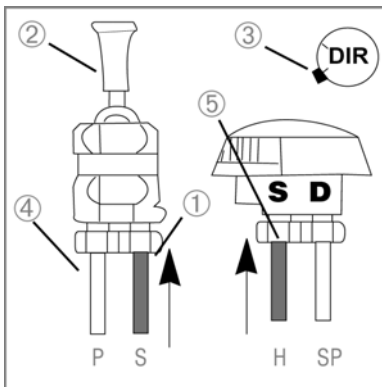

For Underdrive and Overdrive operation (range knob up (2), selector valve button in the forward position (3) air flows through the selector valve “H” port (4) and out the “SP” port (5).

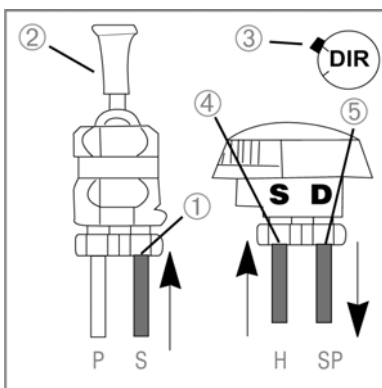

# System Components

---

## A-4900/A-6913 Roadranger Valve

Constant air pressure is supplied from the slave valve to the Roadranger valve “S” port (1).

For LO range (range lever down (2), splitter button rearward (3), air flows out of the Roadranger valve “P” port (4).

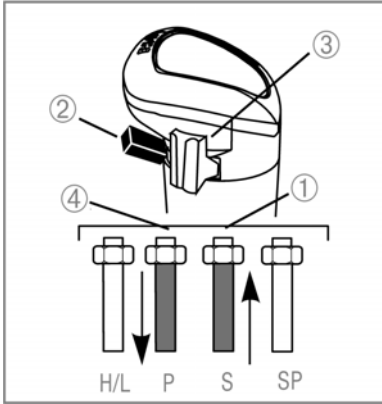

For HI range (range lever up (2), splitter button rearward (3), the lever prevents the air from passing through the Roadranger valve: air now flows through the “H/L” port (4) into the Roadranger valve.

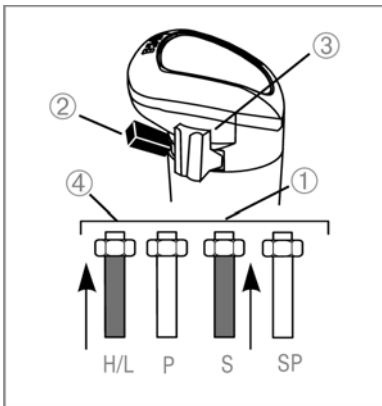

For splitter operation (range lever up (2), splitter button forward (3), air flows through the “H/L” port and air flows out of the Roadranger valve “SP” port (4). Air pressure which was in the outlet line is exhausted out the bottom of the Roadranger valve.

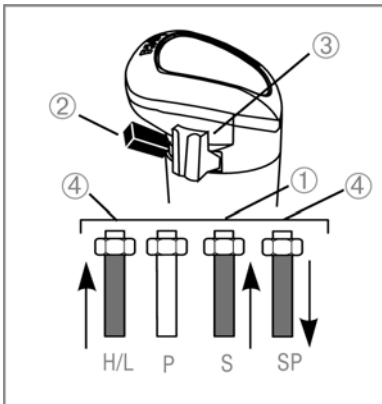

The roadranger valve mechanical interlock prevents forward movement of the splitter button while in LO range.

## A-5013/A-6913 Roadranger Valve

Constant air pressure is supplied from the slave valve to the roadranger valve “S” port (1).

For LO range direct (range lever down (2), actuator button rearward (3), air flows out of the Roadranger valve “P” port (4).

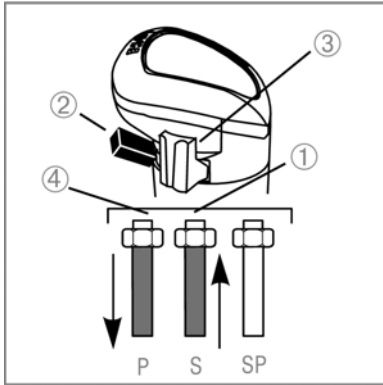

For LO range overdrive (range lever down (2), actuator button forward (3) air flows out of the roadranger valve “P” port and “SP” port (4).

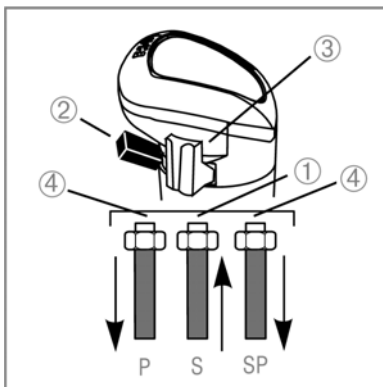

For HI range direct (range lever up (2), actuator button rearward (3), the lever prevents the air from passing through the Roadranger valve (4).

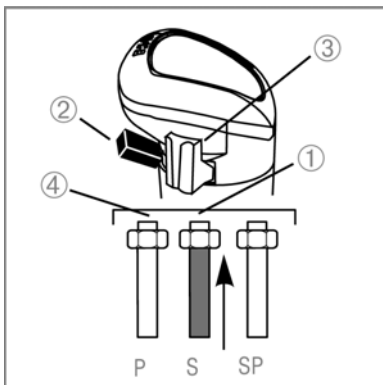

# System Components

---

For HI range overdrive (range lever up (2), actuator button forward (3), air flows out of the Roadranger valve "SP" port (4). Air pressure which was in the outlet line is exhausted out the Roadranger valve bottom.

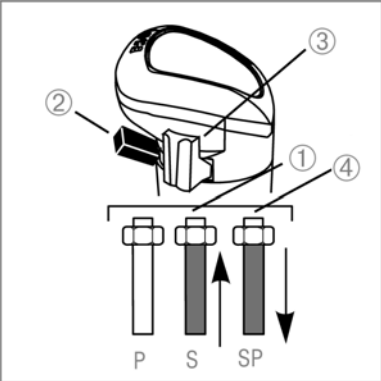

## Three Position Selector Valve

Constant air pressure is supplied from the slave valve to the Roadranger valve “S” port (1).

For LO range (selector button in the “LO” position (2), the air is stopped from passing through the selector valve.

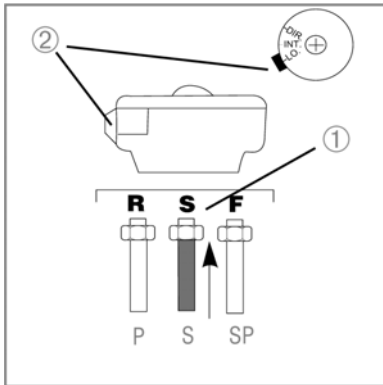

For Intermediate range (selector button in the “INT” position (2), air flows out the “SP” port (3).

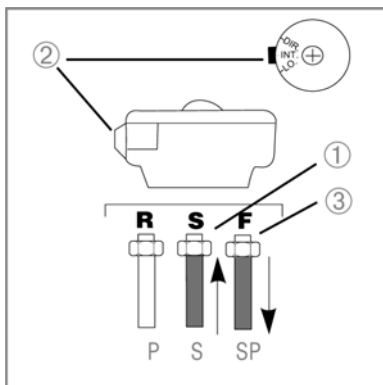

For HI range (selector button in the “DIR” position (2), air flows out the “P” port (3) and the “SP” port (4).

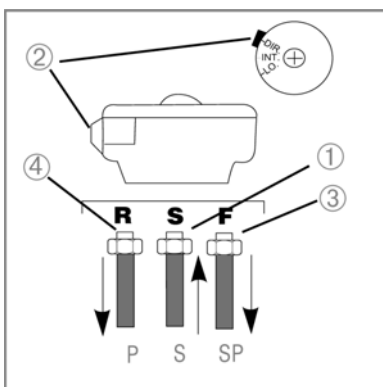



# System Components

---

## A-5510/A-6910 Roadranger Valve

Constant air pressure is supplied from the slave valve to the Roadranger valve “S” port (1).

For LO range 1, 3, 5 gear positions (gear select button in the rearward position (2), the button prevents air from passing through the Roadranger valve.

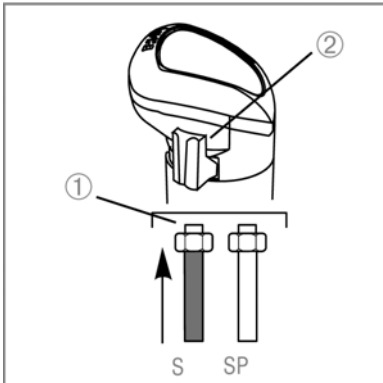

For LO range 2, 4, 6 gear positions (gear select button in the forward position (2), air flows out the roadranger “SP” port.

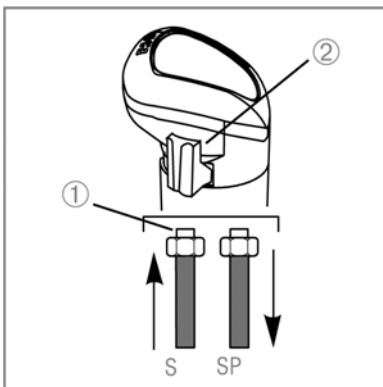

For HI range 7, 9 gear position (gear select button in the rearward position (2), air is again prevented from passing through the Roadranger valve.

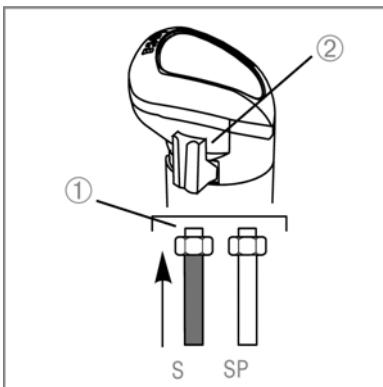

# System Components

For HI range, 8 and 10 gear positions (gear select button in the forward (2) air flows out the roadranger valve "SP" port.

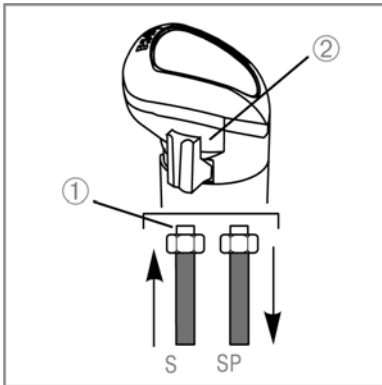

# System Components

---

## Range Actuator Valve (Old Design)

Constant air pressure is supplied from the air filter/regulator to the range actuator valve "S" port tee (1).

For LO range (1, 2, 3, 4, 5, and 6 gear positions) the "S" port (2) is open and the air is allowed to pass through the range actuator valve and out the LO range air line (3).

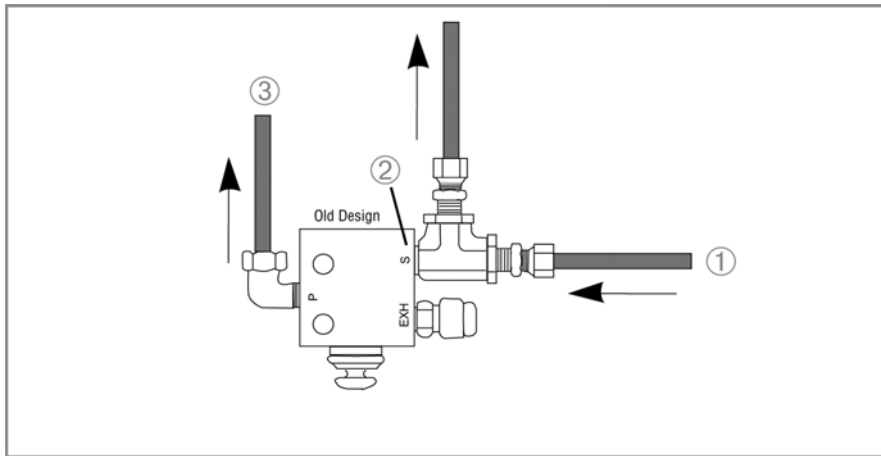

For HI range (7, 8, 9, and 10 gear positions) the "S" port (2) is closed and no air passes through the range actuator valve (3).

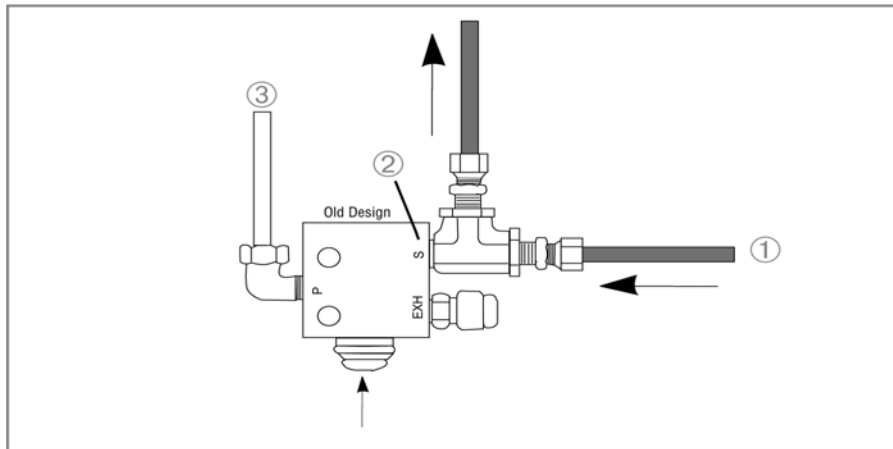

## Range Actuator Valve (Latest Design)

Constant air pressure is supplied from the air filter/regulator to the range actuator valve "S" port tee (1).

For LO range (1, 2, 3, 4, 5, and 6 gear positions) the "S" port is open and the air is allowed to pass through the range actuator valve and out the LO range air line (2).

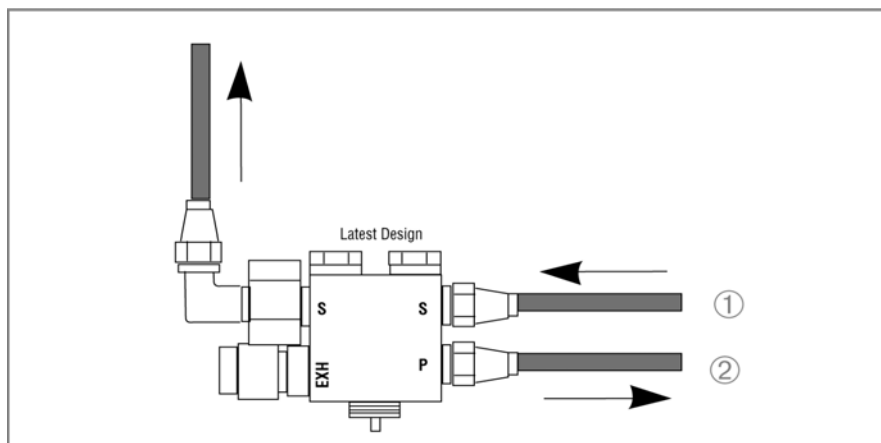

For HI range (7, 8, 9, and 10 gear positions) the "S" port is closed and no air passes through the range actuator valve (2).

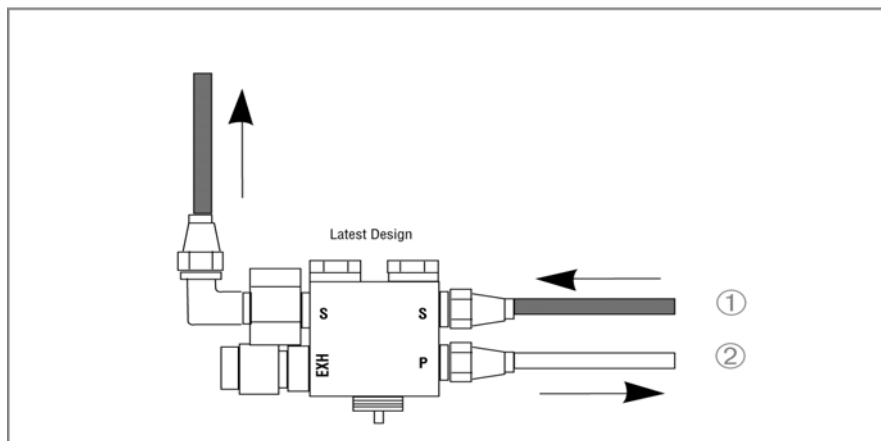

# System Components

---

## 19470 Poppet-Type Slave Valve

The poppet-type slave valve is a non-serviceable valve. Should this valve prove to be defective replace the complete assembly with A-5000. There are some preliminary checks to make before replacing the slave valve: check air fittings for restrictions, check torque of the four (4) mounting capscrews (8-12 lbs. ft.), if valve continues to leak replace.

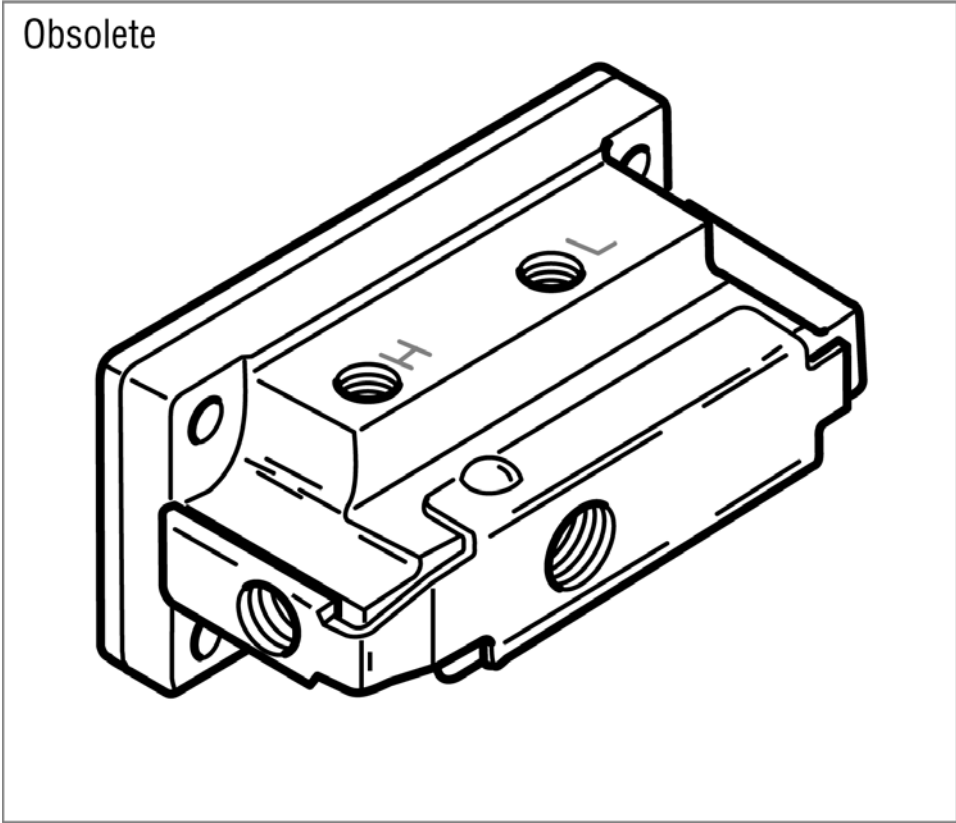

## A-4688 Slave Valve

**LO Range** - Air pressure is supplied to the end cap (1) from the selector/master/Roadranger valve (2). The piston is held forward since the surface area is larger on this end (3) than the surface area at the other end (4) and is exposed to constant air pressure. The constant air flows through the piston center passage (5) which is aligned with the side cap LO range port (6). In normal operation, exhaust occurs only for an instant as the range shift is made.

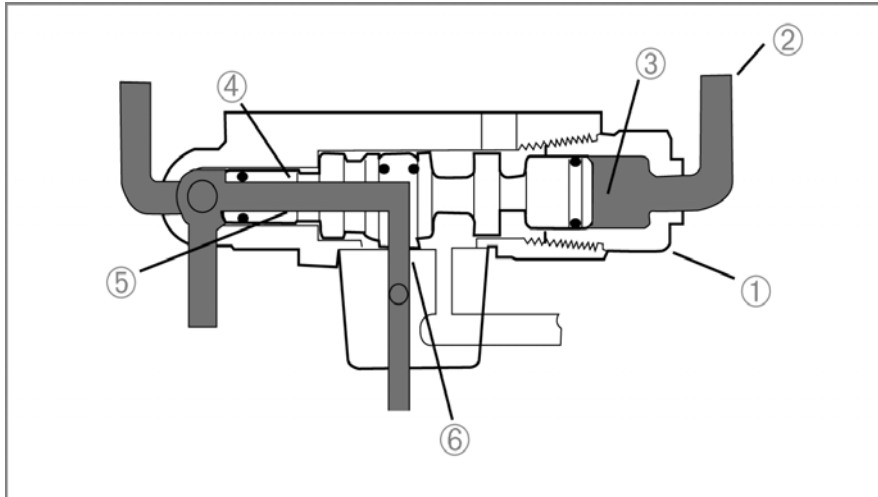

**HI Range** - No air pressure is supplied to the end cap (1) from the selector/master/Roadranger valve (2). The constant air pressure entering the supply port (3) moves the piston to the rear position (4). The constant air flows through the piston center passage (5) which is aligned with the side cap HI range port (6). In normal operation, exhaust occurs only for an instant as the range shift is made.

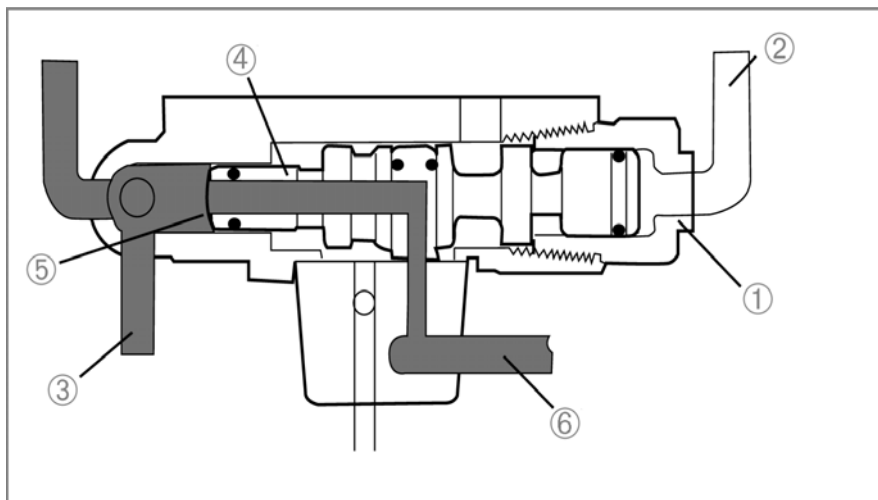

# System Components

## A-5000 Slave Valve

**LO Range** - Air pressure is supplied to the end cap (1) from the selector/master/Roadranger valve (2). The piston is held forward since the surface area is larger on this end (3) than the surface area at the other end (4) and is exposed to constant air pressure. The constant air flows through the piston center passage (5) which is aligned with the side cap LO range port (6). In normal operation, exhaust occurs only for an instant as the range shift is made.

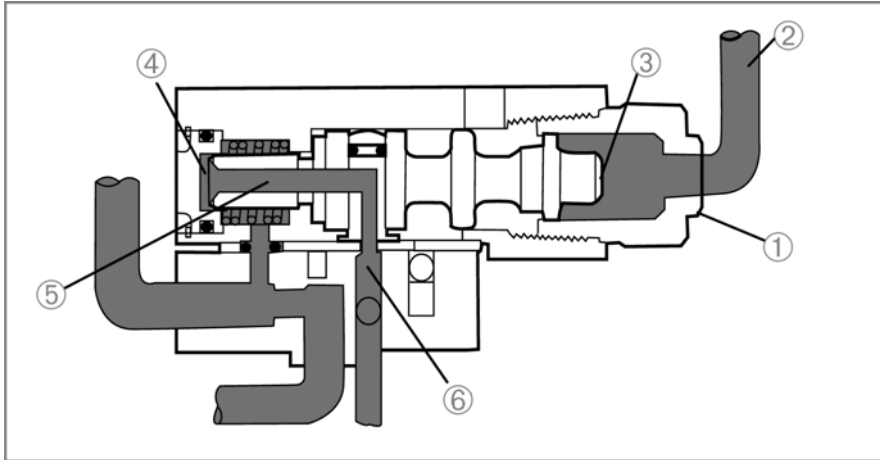

**HI Range** - No air pressure is supplied to the end cap (1) from the selector/master/Roadranger valve (2). The constant air pressure entering the supply port (3) moves the piston to the rear position (4). The constant air flows through the piston center passage (5) which is aligned with the side cap HI range port (6). In normal operation, exhaust occurs only for an instant as the range shift is made.

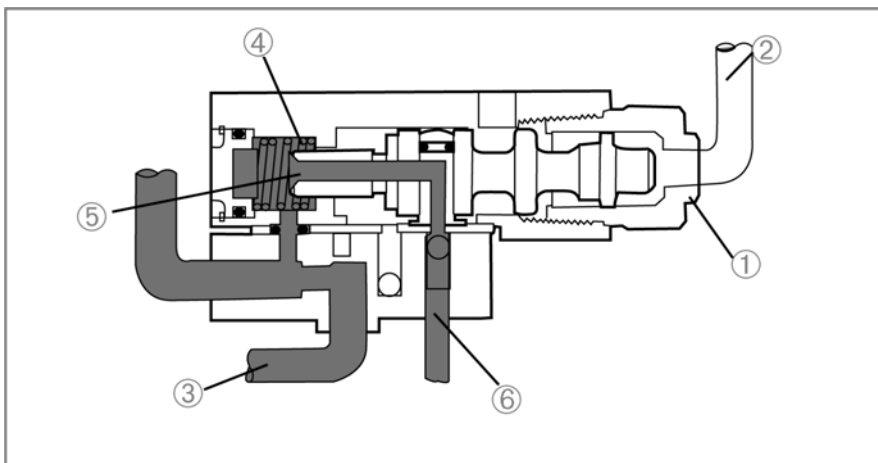

## Range Cylinder

**LO Range** - With the control valve lever down, air is supplied from the slave valve to the range cylinder LO range port (1). This air pressure forces the range cylinder piston to the rear (2), engaging the LO range gearing. Air pressure on the piston back, and in the HI range air hose (3), is exhausted out the slave valve.

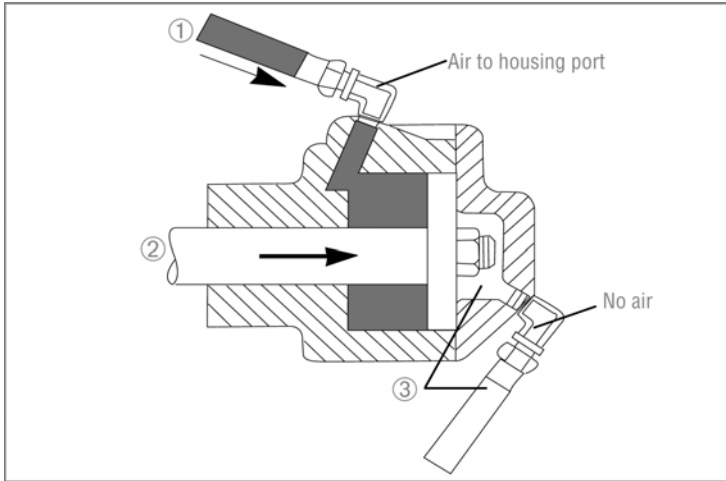

**HI Range** - With the control valve lever up, air is supplied from the slave valve to the range cylinder cover HI range port (1). This air pressure forces the range cylinder piston forward (2), engaging the HI range gearing. Air pressure on the piston front side and in the LO range air hose (3), during LO range operation, is exhausted out the slave valve.

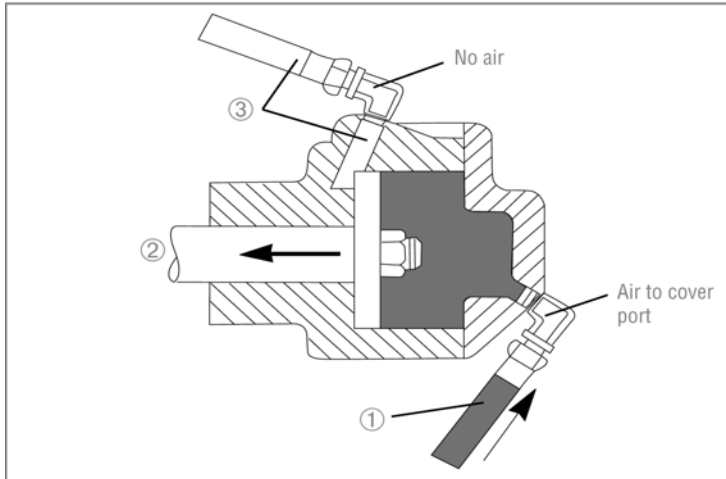



# System Components

## Range Cylinder for 610, 6610, 6609 and 8609

**LO Range** - With the control valve lever down, air is supplied from the slave valve to the range cylinder LO range port (1). This air pressure forces the range cylinder piston to the rear (2), engaging the LO range gearing. Air pressure on the piston back, and in the HI range air hose (3), is exhausted out the slave valve.

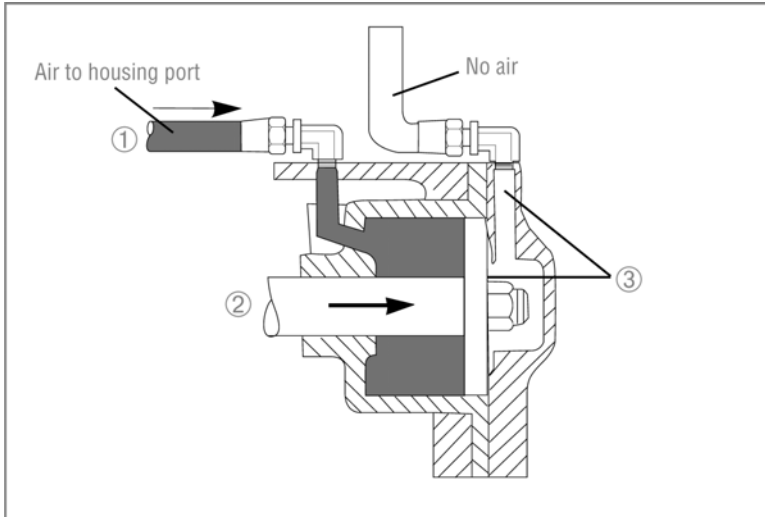

**HI Range** - With the control valve lever up, air is supplied from the slave valve to the range cylinder cover HI range port (1). This air pressure forces the range cylinder piston forward (2), engaging the HI range gearing. Air pressure on the piston front side and in the LO range air hose (3), during LO range operation, is exhausted out the slave valve.

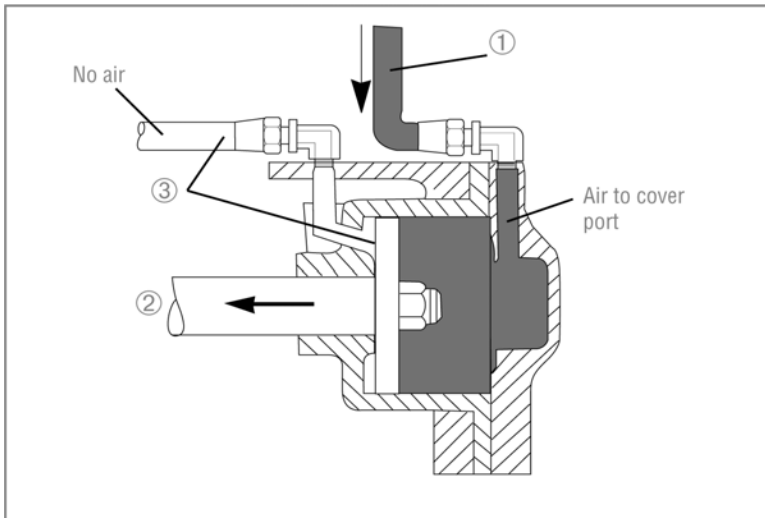

## Dash-Mounted Deep Reduction Cylinder

**Deep Reduction** - With the deep reduction lever in the "IN" position, no air is supplied to the cylinder cover center port (1). Constant air from the air filter/regulator assembly (2) moves the reduction piston rearward (3), engaging deep reduction gearing.

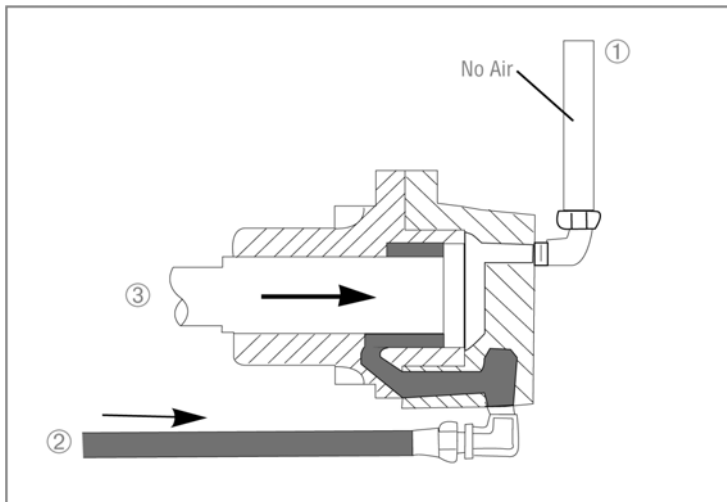

**LO Range or HI Range** - With the deep reduction lever in the "OUT" position, air is supplied to the cylinder cover center port (1), moving the reduction piston forward (2), disengaging deep reduction gearing.

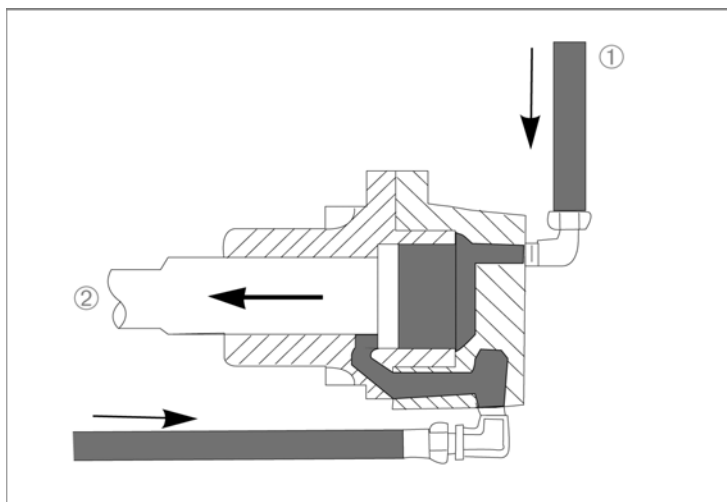

# System Components

---

## Deep Reduction Cylinder with Roadranger Valve

**Deep Reduction** - With the deep reduction button in the "forward" position, air is supplied to the deep reduction cylinder cover center port (1), moving the the reduction piston rearward, engaging deep reduction gearing (2).

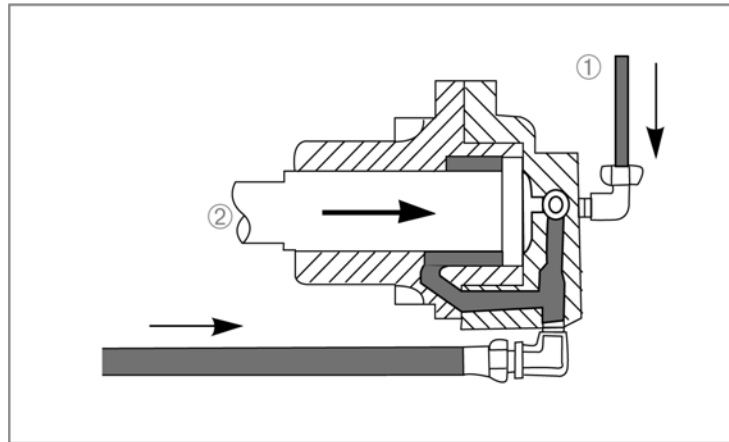

**LO or HI Range** - With the deep reduction lever in the "rearward" position, no air is supplied to the deep reduction cylinder cover center port (1). The constant air from the air filter/regulator assembly (2) moves the reduction piston forward, disengaging deep reduction gearing (3).

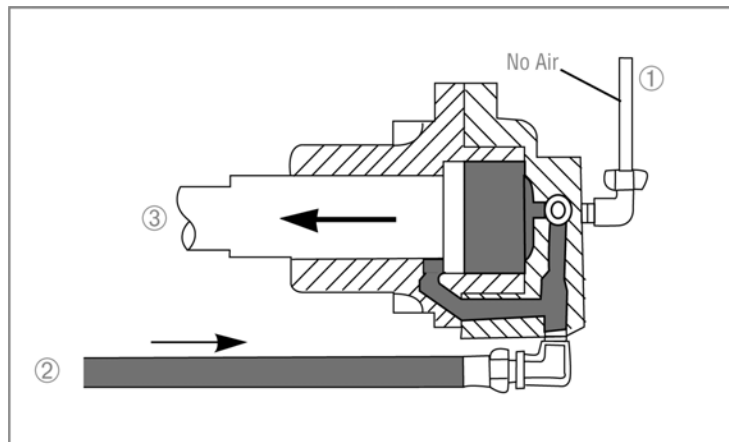

## Insert Valve

The insert valve is a self-contained 1-13/16" valve assembly located in the reduction cylinder cover. It cannot be disassembled except for the three (3) o-rings on the outer diameter. The o-rings provide a stationary seal and do not move in the cylinder.

Insert valve piston travel is only 1/32". When air is applied to the valve piston top side through the signal line, the piston moves down to cut off air supplied to the cylinder piston backside. This air is exhausted out the cover bottom port when constant air supplied from the regulator is directed to the cylinder piston front side, moving the yoke bar rearward to engage deep reduction gearing.

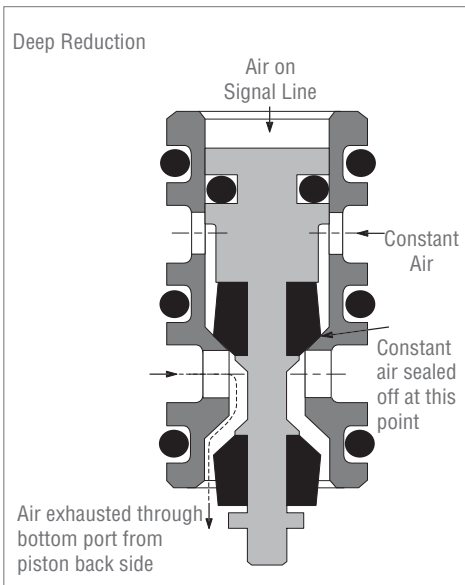

When no air is applied to the valve piston top side, constant air supplied from the air filter/regulator passes freely through the insert valve and to the cylinder piston backside, moving the yoke bar forward to disengage deep reduction gearing.

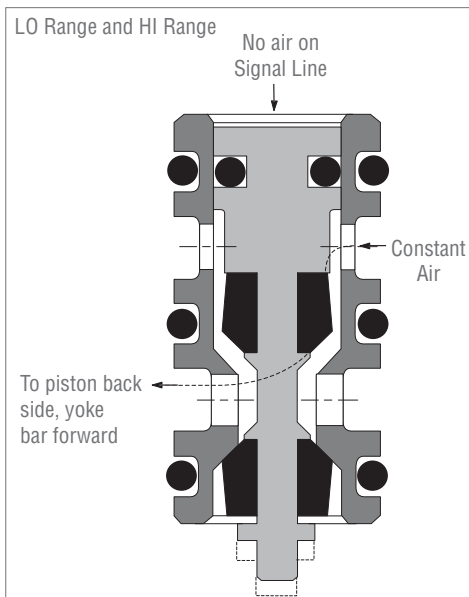

System Components

# System Components

## RTLO-xx610 Model Range Cylinder Assembly

**Note:** This is the Old design

**LO Range** - When the shift lever is moved laterally from 7th to 6th gear, air is supplied to the range cylinder housing port (1), moving the piston rearward, engaging LO range gearing (2).

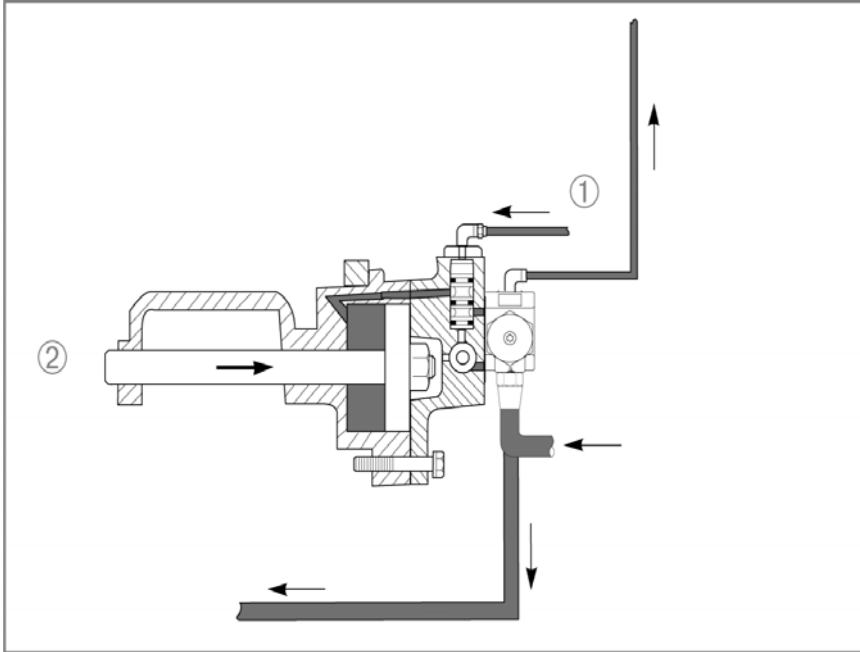

**HI Range** - When the shift lever is moved laterally from 6th to 7th gear, no air is supplied to the range cylinder housing port (1), moving the piston forward, engaging HI range gearing (2).

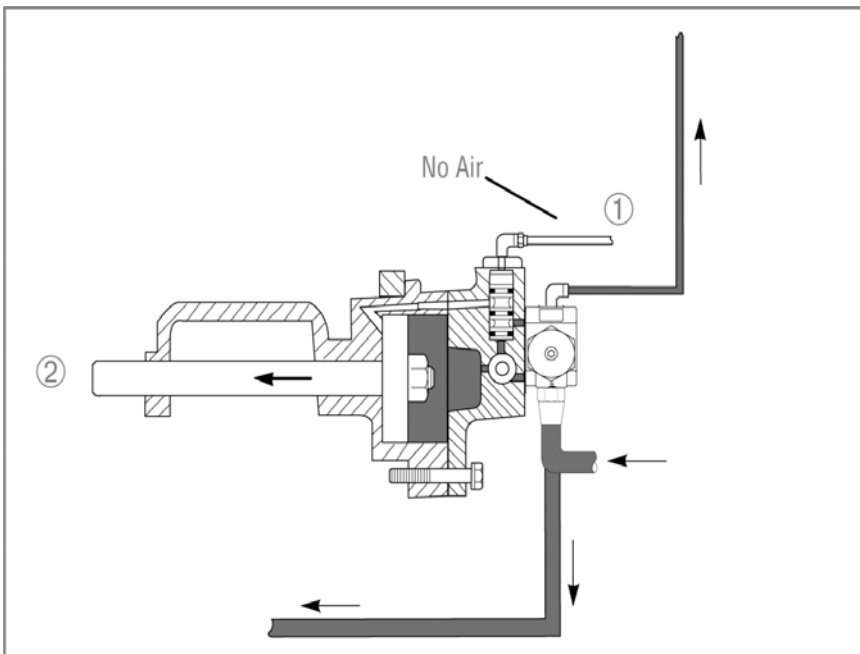

## Insert Valves

The insert valves are a self-contained 1-1/2" valve assembly located in the range cylinder cover. It cannot be disassembled except for the three (3) o-rings on the outer diameter. The o-rings provide a stationary seal and do not move in the cylinder.

Insert valve piston travel is only 1/16". When air is applied to the valve piston top side, one piston moves down sealing off the constant air supplied from the air filter/regulator, the other piston allows the constant air supplied from the air filter/regulator to pass freely through the insert valve, to the cylinder piston front side, moving the yoke bar rearward to engage the LO range gearing.

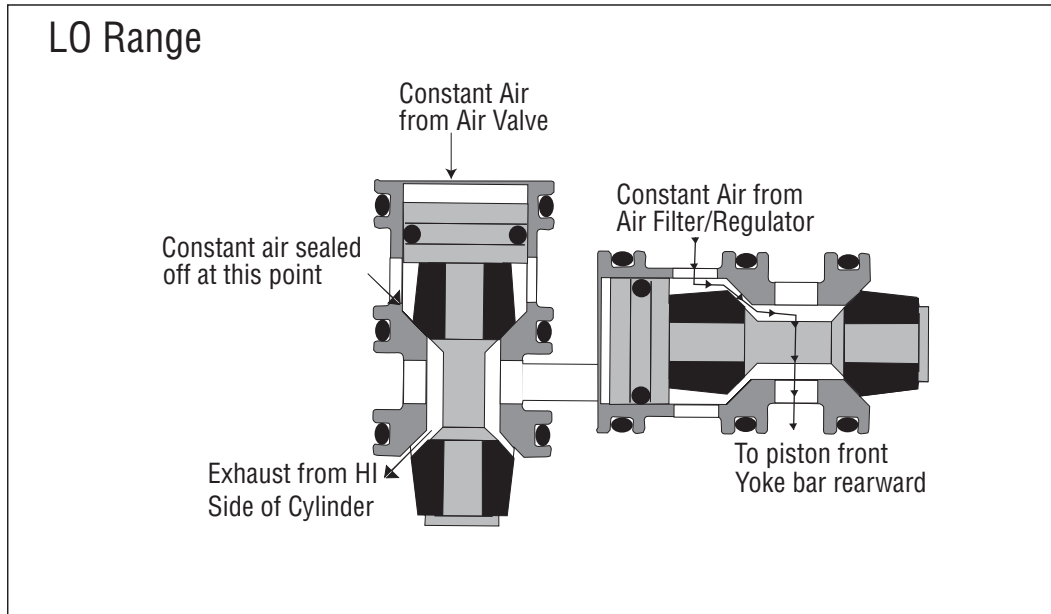

When no air is applied to the signal line, the piston moves up allowing the constant air supplied from the air filter/regulator to pass freely through one insert valve to the piston back side, moving the yoke bar forward to engage HI range gearing and sealing off the constant air from the air filter/regulator to allow the air from the piston front side to exhaust.

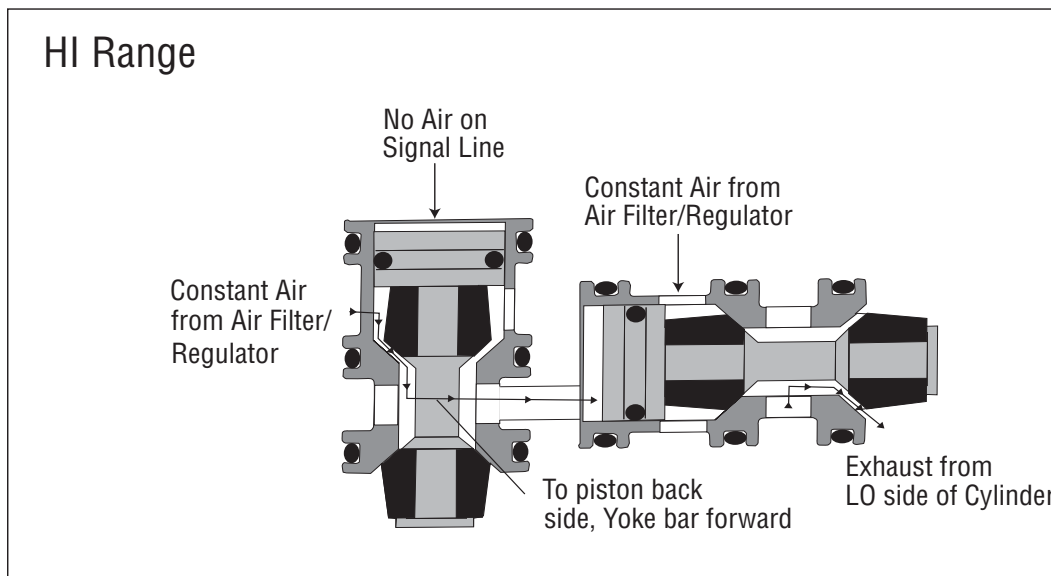

# System Components

## RTL-xx710 Model Range Cylinder Assembly

**LO Range** - When the shift lever is moved laterally from 7th to 6th gear, air is supplied to the range cylinder housing port (1), moving the the piston rearward, engaging LO range gearing (2).

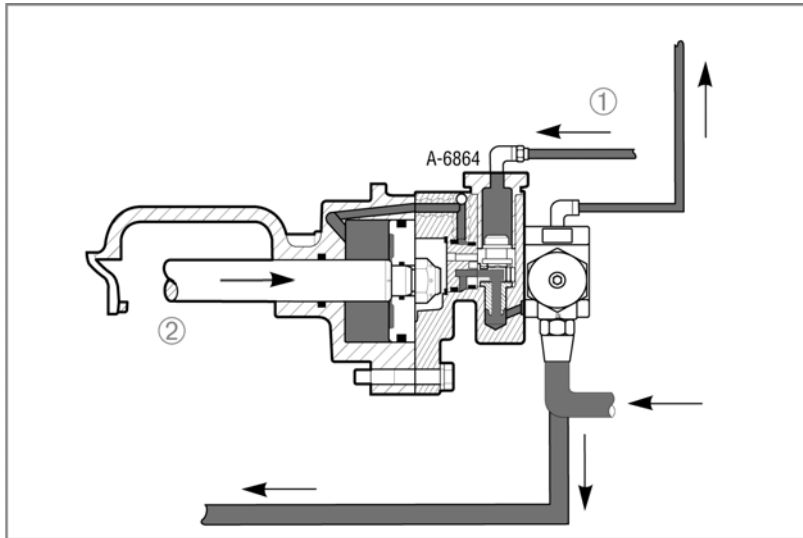

**HI Range** - When the shift lever is moved laterally from 6th to 7th gear, no air is supplied to the range cylinder housing port (1), moving the piston forward, engaging HI range gearing (2).

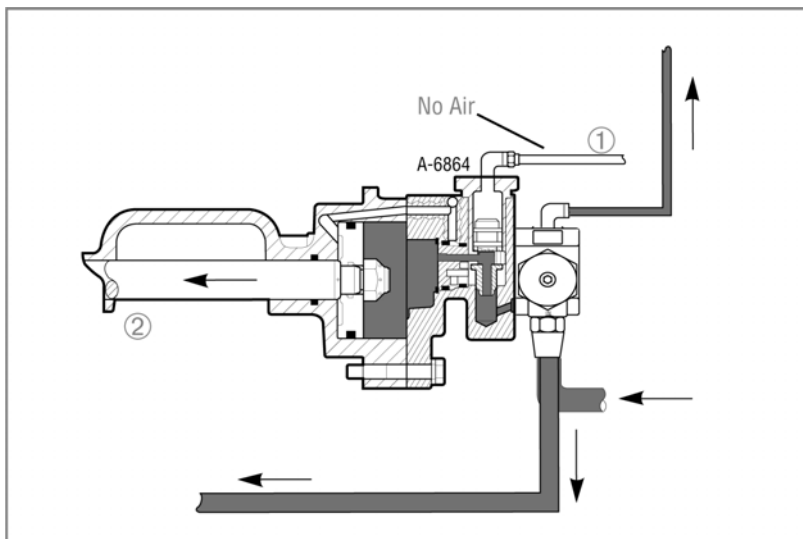

## Spool Valve

The spool valve components shown are part of a self-contained valve assembly, part number A-6864.

The spool valve piston travel is approximately 1/2". When filtered air is supplied from the 4303110 valve to the valve spool right side (1), constant air from the filter/regulator (2) flows through the valve spool and seal plate to the range cylinder piston front side moving the yoke bar rearwards. Air is exhausted from the range cylinder rear (3).

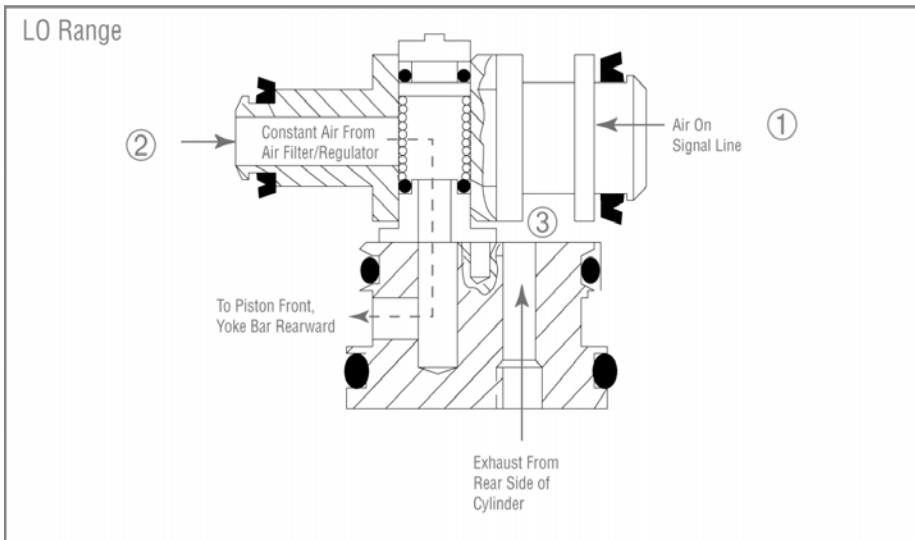

When no filtered air is supplied from the 4303110 valve to the valve spool right side (1), constant air from the filter/regulator (2) flows through the valve spool and seal plate to the range cylinder piston back side moving the yoke bar forward. Air is exhausted from the range cylinder front (3).

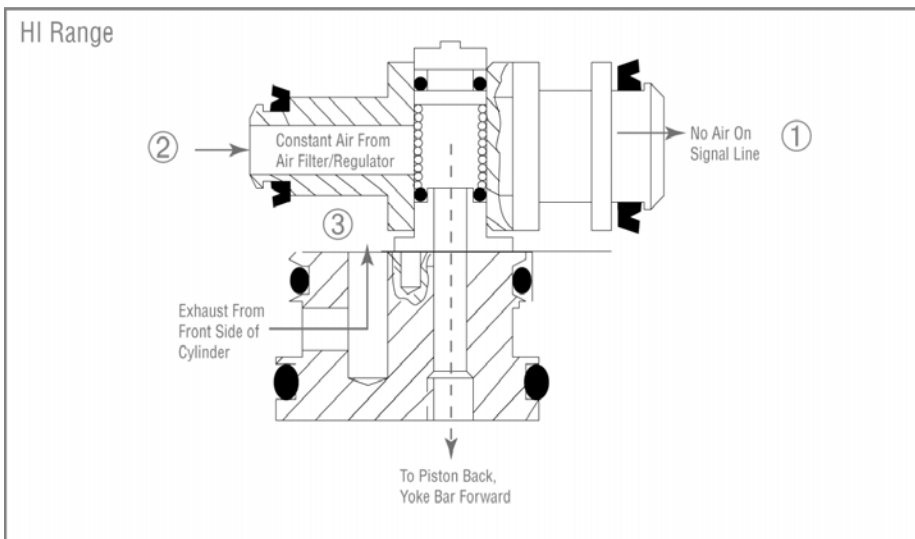

System Components



# System Components

## Intermediate Shift Cylinder Assembly 613 and 6613, 3-Position Selector Valve

**LO Range** - With the Selector valve button in the "LO" position, no air is supplied to the Intermediate cylinder cover center port (1). The constant air from the air filter/regulator assembly (2) moves the piston forward (3), disengaging underdrive/overdrive gearing.

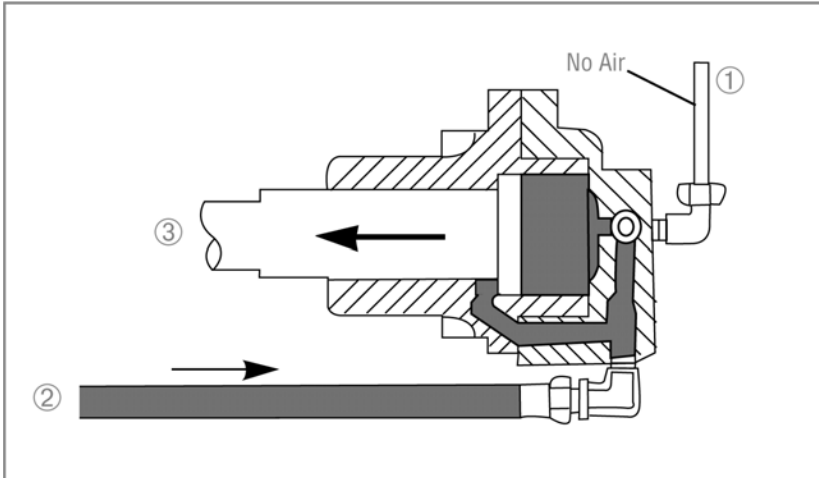

**Intermediate or Direct Range** - With the Selector valve button in the "INT" or "DIR" position, air is supplied to the Intermediate cylinder cover center port (1), moving the piston rearward, engaging underdrive/overdrive gearing (2).

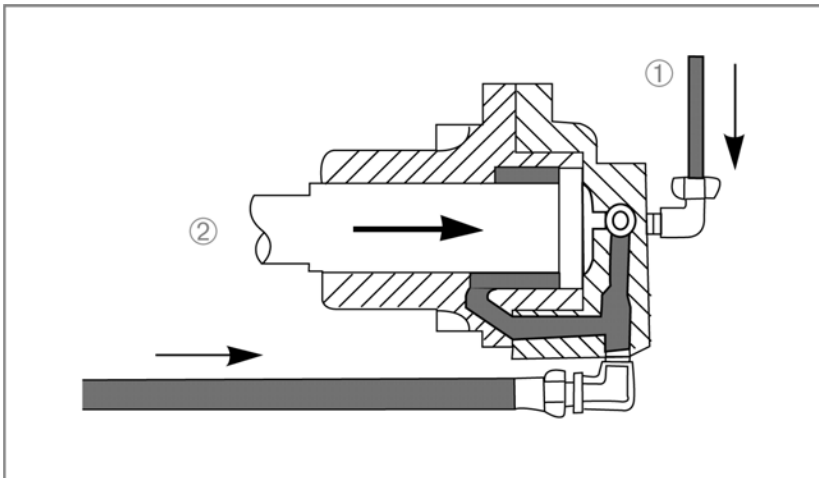

## Insert Valve

The insert valve is a self-contained 1-13/16" valve assembly located in the intermediate cylinder cover. It cannot be disassembled except for the three (3) O-rings on the outer diameter. The O-rings provide a stationary seal and do not move in the cylinder.

Insert valve piston travel is only 1/32". When no air is applied to the valve piston top side, constant air supplied from the air filter/regulator passes freely through the insert valve and to the cylinder piston backside, moving the yoke bar forward to disengage underdrive/overdrive gearing.

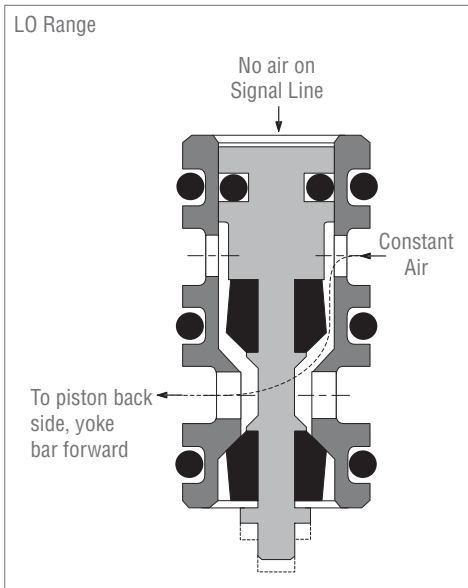

When air is applied to the valve piston top side through the signal line, the piston moves down to cut off air supplied to the cylinder piston backside. This air is exhausted out the cover bottom port when constant air supplied from the regulator is directed to the cylinder piston front side, moving the yoke bar rearward to engage intermediate or direct gearing.

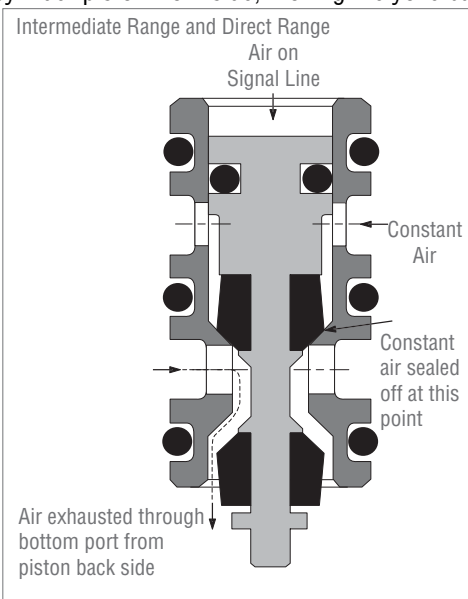

# System Components

## Intermediate Shift Cylinder Assembly 613 and 6613, A-5015 Roadranger Valve

**Deep Reduction** - With the Roadranger valve lever in the up position, air is supplied to the Intermediate cylinder cover port (1), moving the piston forward, engaging deep reduction gearing (2).

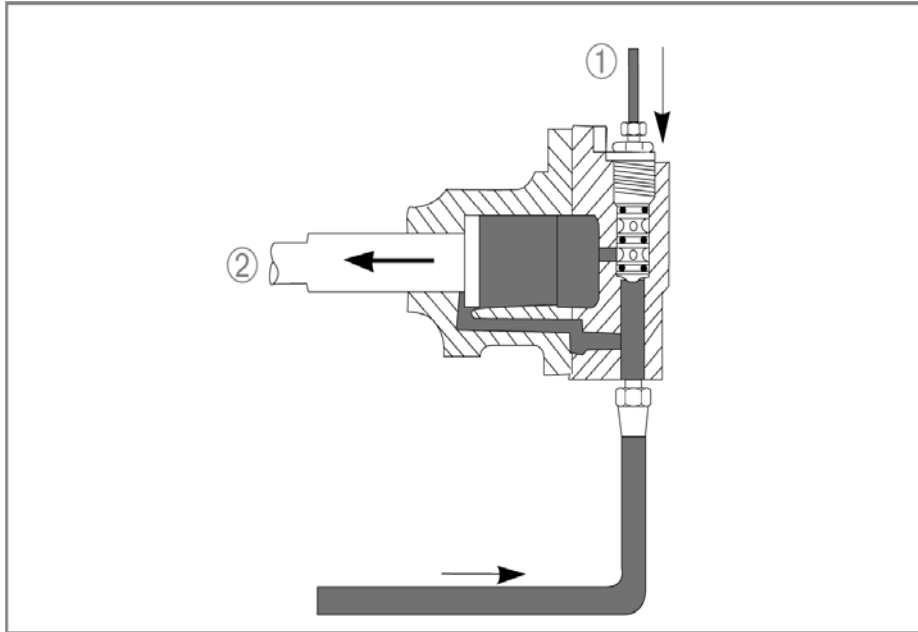

**LO or HI Range** - With the Roadranger valve lever in the down position, no air is supplied to the Intermediate cylinder cover port (1). The constant air from the air filter/regulator assembly (2) moves the piston rearward (3), disengaging deep reduction gearing.

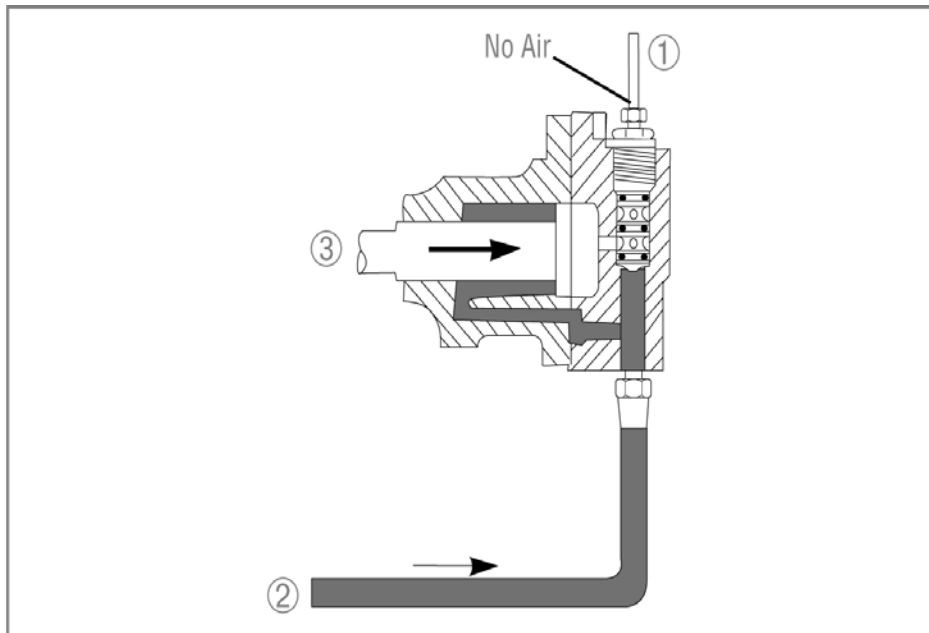

## Insert Valve

The insert valve is a self-contained 1-13/16" valve assembly located in the intermediate cylinder cover. It cannot be disassembled except for the three (3) O-rings on the outer diameter. The O-rings provide a stationary seal and do not move in the cylinder.

Insert valve piston travel is only 1/32". When air is applied to the valve piston top side through the signal line, constant air supplied from the air filter/regulator passes freely through the insert valve and to the cylinder piston backside, moving the yoke bar forward to engage deep reduction gearing.

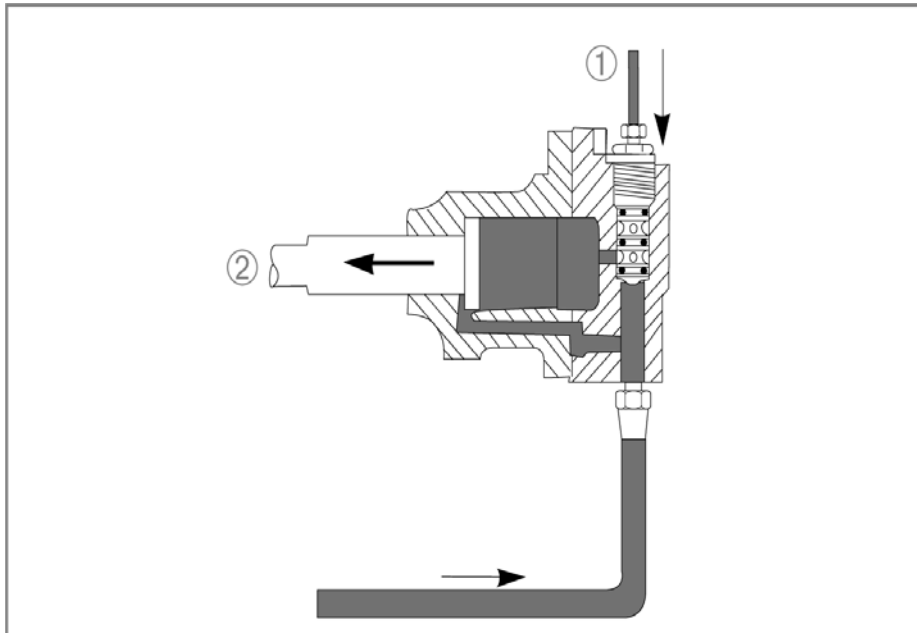

When no air is applied to the valve piston top side, the piston moves up to cut off air supplied to the cylinder piston backside. This air is exhausted out the cover back center bore, when constant air supplied from the cylinder is directed to the cylinder piston front side, the yoke bar moves rearward to disengage deep reduction gearing.

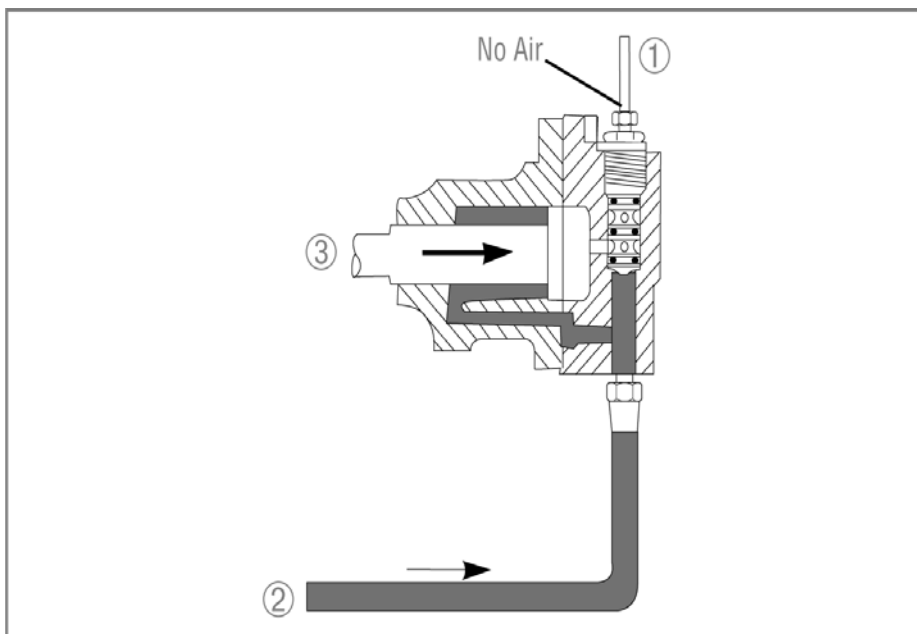

# System Components

## Combination Cylinder Assembly

The combination cylinder combines the range operation with the deep reduction operation. Each functions separately, but are contained in the same housing.

**Deep Reduction** - With the range lever in the "down" position, air is supplied to the LO range port (1), moving the range piston rearward to engage LO range gearing (2), and the deep reduction button is in the "forward" position. Air is supplied to the deep reduction cylinder cover center port (3), moving the reduction piston rearward (4), and engaging deep reduction gearing.

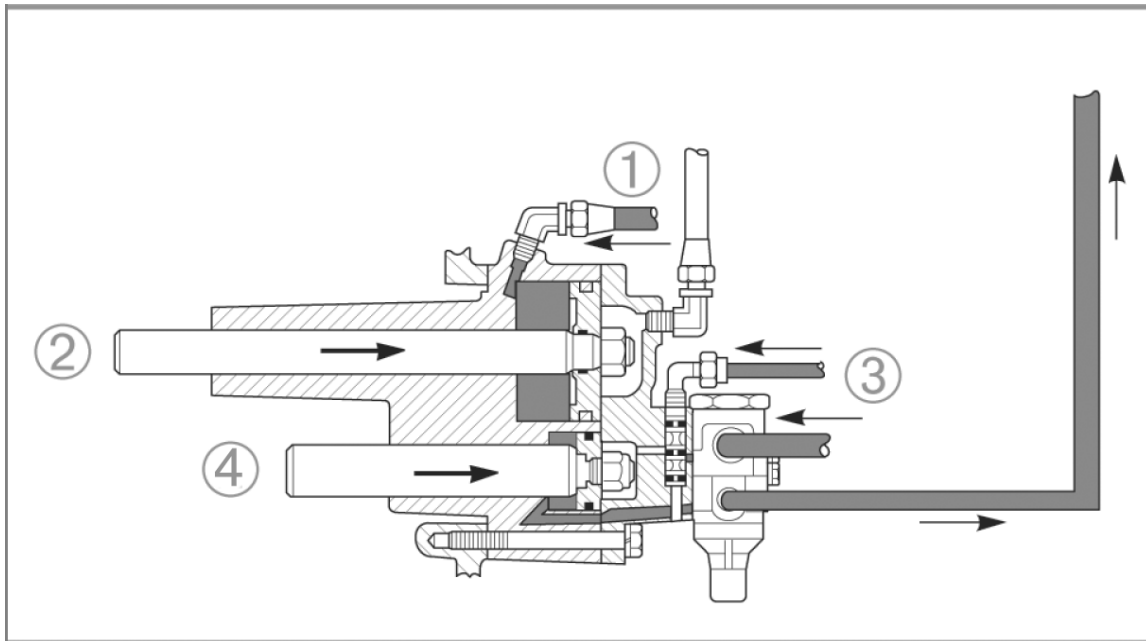

**LO Range** - With the range lever in the "down" position, air is supplied to the LO range port (1), moving the range piston rearward (2), engaging LO range gearing AND the deep reduction button is in the "rearward" position. No air is supplied to the deep reduction cylinder cover center port (3). The constant air from the air filter/regulator assembly moves the reduction piston forward (4), disengaging deep reduction gearing.

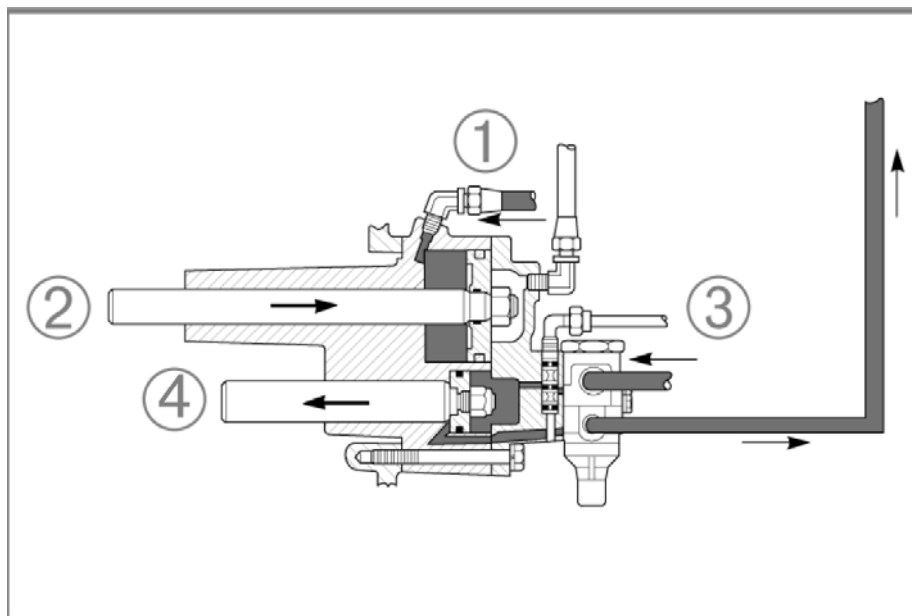

**HI Range** - With the range lever in the "up" position, air is supplied to the HI range port (1), moving the range piston forward (2), engaging HI range gearing AND the deep reduction button is in the "rearward" position. No air is supplied to the deep reduction cylinder cover center port (3). The constant air from the air filter/regulator assembly moves the reduction piston forward (4), disengaging deep reduction gearing.

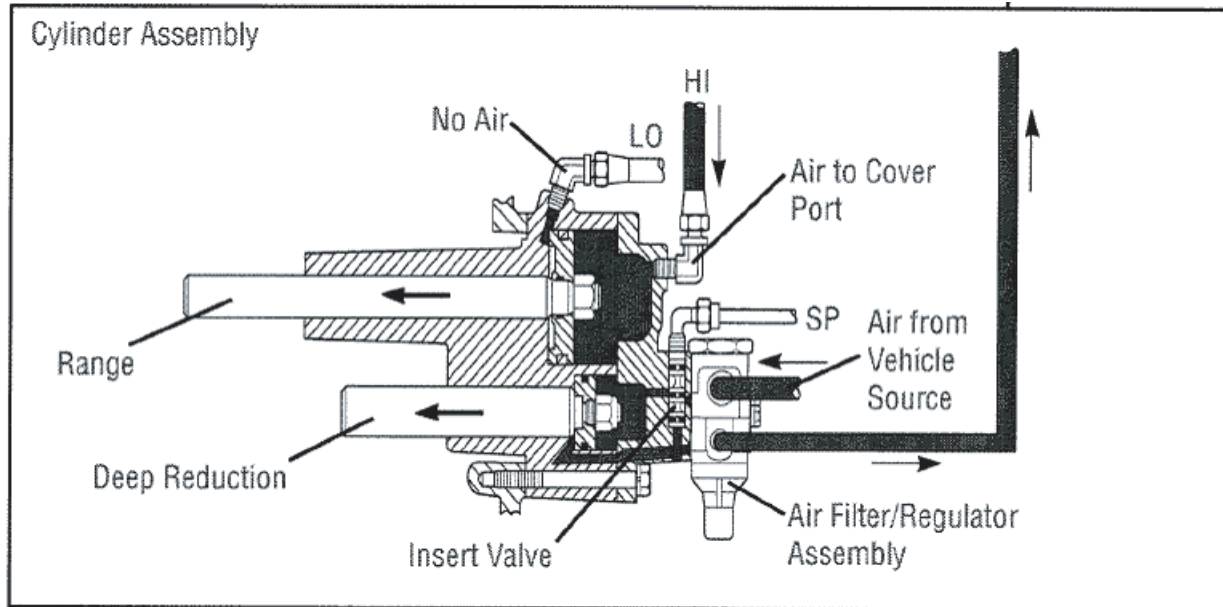

## Insert Valve

The insert valve is a self-contained 1-13/16" valve assembly located in the intermediate cylinder cover. It cannot be disassembled except for the three (3) O-rings on the outer diameter. The O-rings provide a stationary seal and do not move in the cylinder.

Insert valve piston travel is only 1/32". When air is applied to the valve piston top side through the signal line, the piston moves down to cut off air supplied to the cylinder piston backside. This air is exhausted out the cover bottom port when constant air, supplied from the regulator, is directed to the cylinder piston frontside, moving the yoke bar rearward to engage deep reduction gearing.

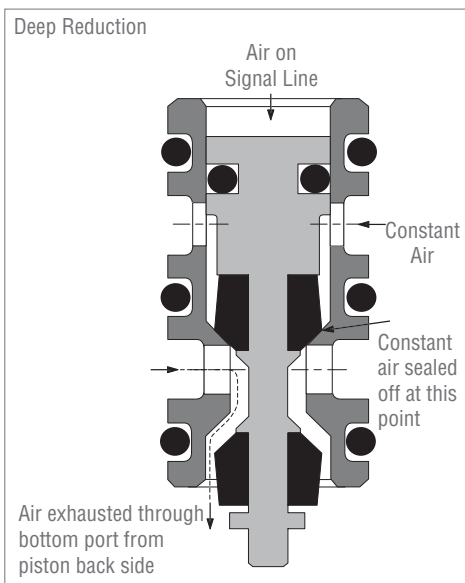

System Components

# System Components

When no air is applied to the valve piston top side, constant air supplied from the air filter/regulator passes freely through the insert valve and to the cylinder piston backside, moving the yoke bar forward to disengage deep reduction gearing.

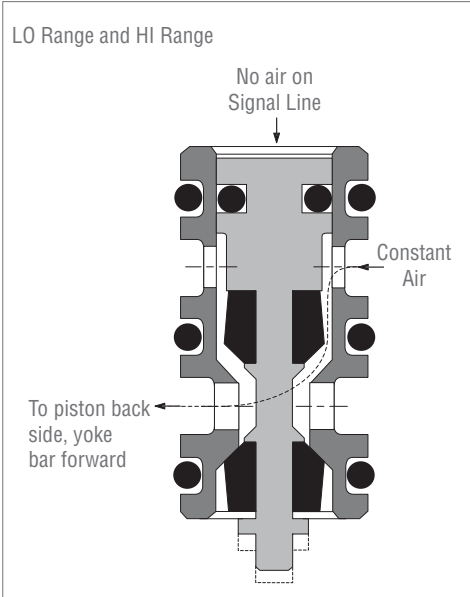

## Splitter Cylinder Assembly

**LO Range or Direct** - With the splitter button in the "rearward" position, no air is supplied to the splitter cylinder cover center port (1). The constant air from the air filter/regulator assembly (2) moves the splitter piston forward, disengaging underdrive/overdrive gearing (3).

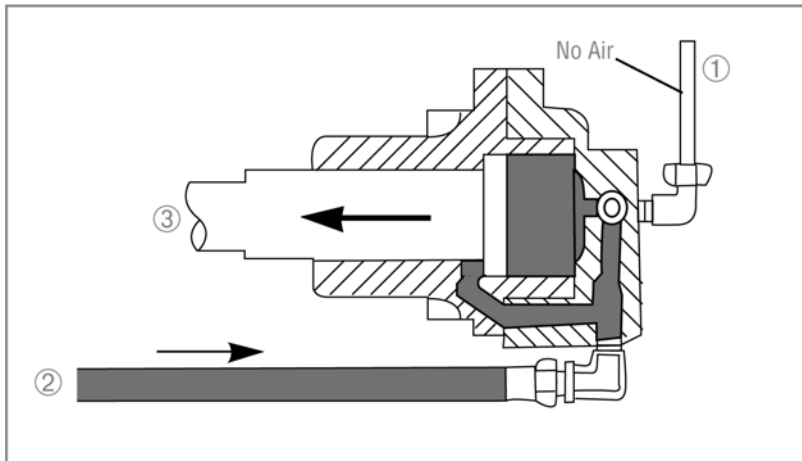

**Underdrive/Overdrive** - With the splitter button in the "forward" position, air is supplied to the splitter cylinder cover center port (1), moving the splitter piston rearward, engaging underdrive/overdrive gearing (2).

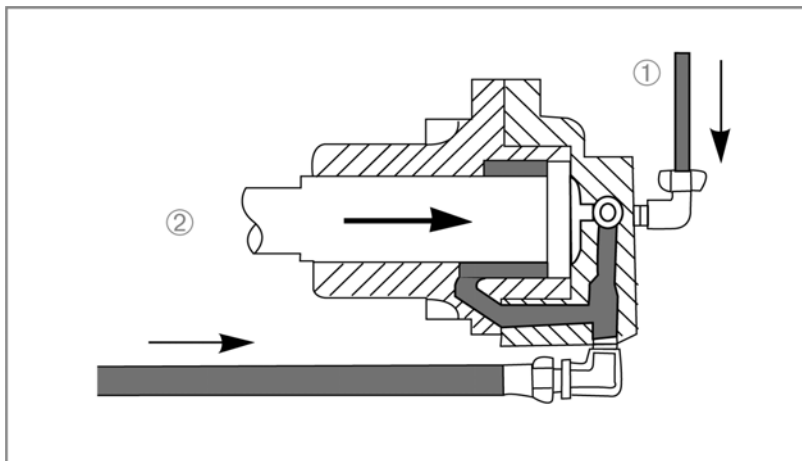



# System Components

## Insert Valve

The insert valve is a self-contained 1-13/16" valve assembly located in the intermediate cylinder cover. It cannot be disassembled except for the three (3) O-rings on the outer diameter. The O-rings provide a stationary seal and do not move in the cylinder.

Insert valve piston travel is only 1/32". When no air is applied to the valve piston top side, constant air supplied from the air filter/regulator passes freely through the insert valve and to the cylinder piston backside, moving the yoke bar forward to disengage underdrive/overdrive gearing.

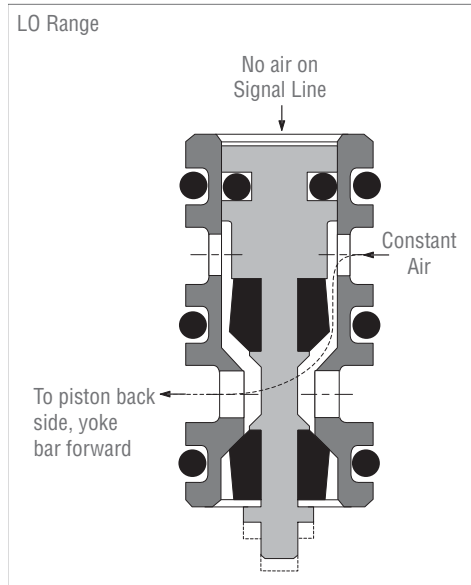

When air is applied to the valve piston top side through the signal line, the piston moves down to cut off air supplied to the cylinder piston backside. This air is exhausted out the cover bottom port when constant air supplied from the regulator is directed to the cylinder piston front side, moving the yoke bar rearward to engage underdrive/overdrive gearing.

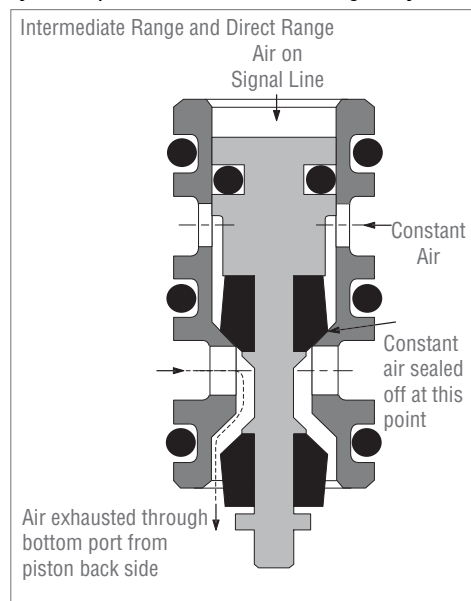

## RTLO-xx610 Model Splitter Cylinder Assembly (Old Design)

**Odd Numbered Gear Positions (1, 3, 5, 7, 9)** With the Roadranger valve button in the rearward position, no air is supplied to the splitter cylinder cover port (1), moving the piston rearward, disengaging splitter gearing (2).

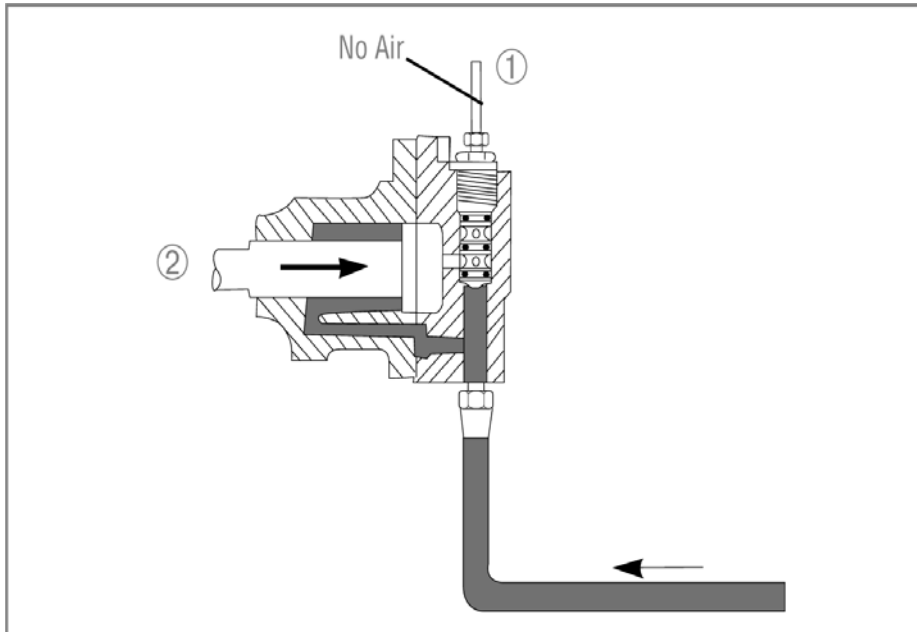

**Even Numbered Gear Positions (2, 4, 6, 8, 10)** With the Roadranger valve button in the forward position, air is supplied to the splitter cylinder cover port (1), moving the piston forward, engaging splitter gearing (2).

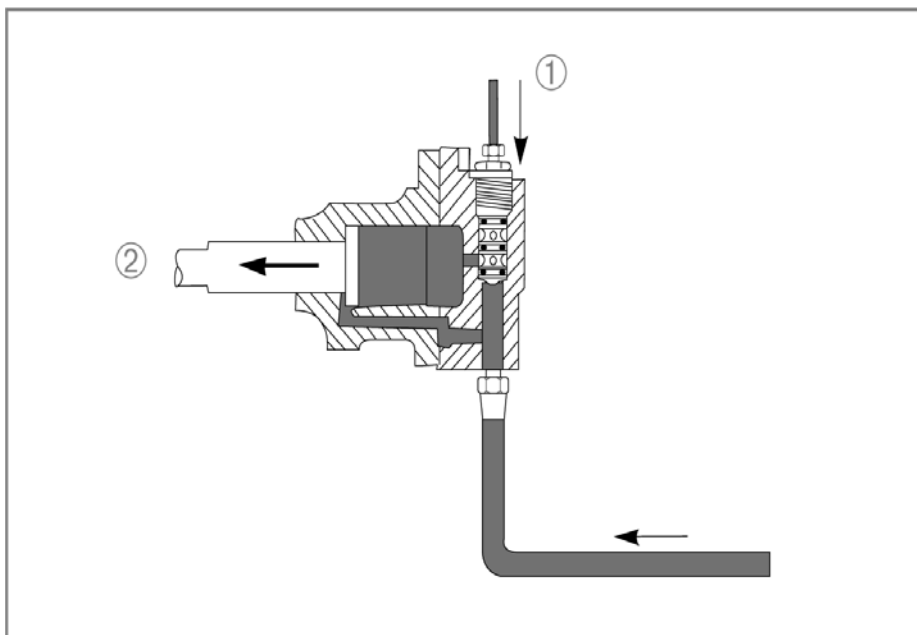

# System Components

## Insert Valve

The insert valve is a self-contained 1-13/16" valve assembly located in the splitter cylinder cover. It cannot be disassembled except for the three (3) O-rings on the outer diameter. The O-rings provide a stationary seal and do not move in the cylinder.

Insert valve piston travel is only 1/32". When no air is applied to the valve piston top side through the signal line, constant air supplied from the air filter/regulator moves the yoke bar rearward to engage the rear auxiliary drive gear (LO and HI range direct), while air is exhausted out the insert valve.

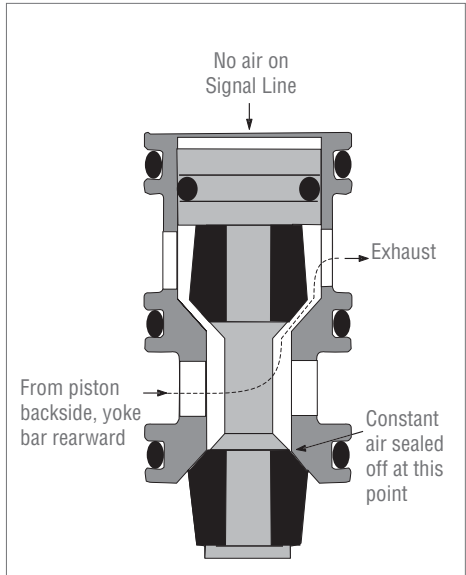

When air is applied to the valve piston top side, the piston moves down passing air through the insert valve bottom to the cylinder piston front and backside, moving the yoke bar forward to engage the front auxiliary drive gear (LO and HI range overdrive).

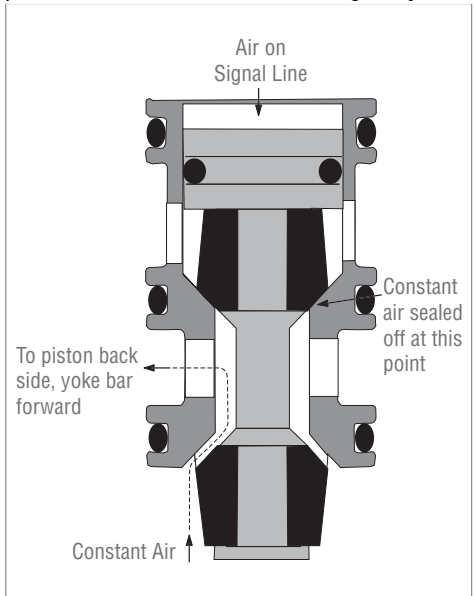

## RTLO-xx610 Model Splitter Cylinder Assembly (Latest Design)

**Odd Numbered Gear Positions (1, 3, 5, 7, 9)** With the Roadranger valve button in the rearward position, no air is supplied to the splitter cylinder cover port (1), moving the piston rearward, disengaging splitter gearing (2).

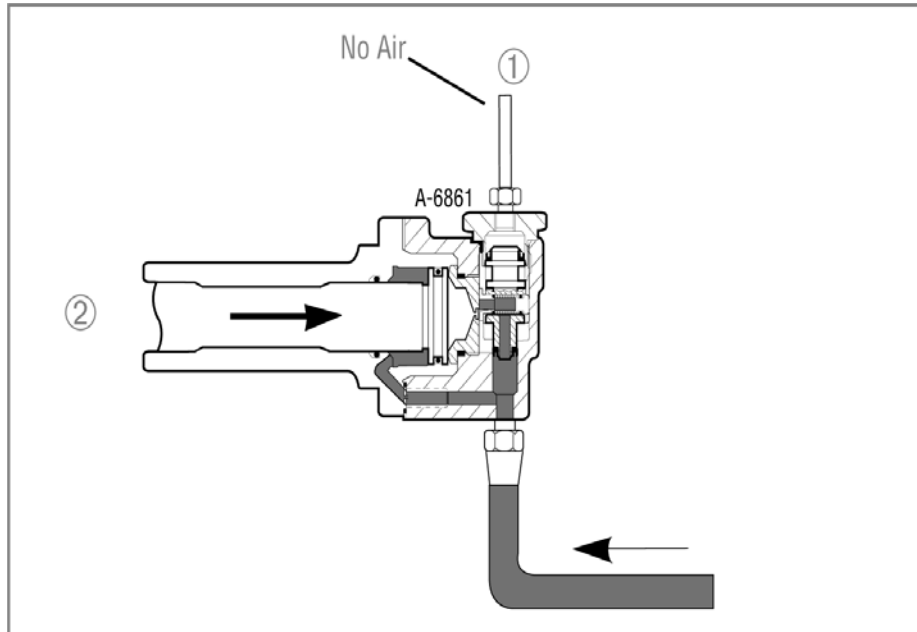

**Even Numbered Gear Positions (2, 4, 6, 8, 10)** With the Roadranger valve button in the forward position, air is supplied to the splitter cylinder cover port (1), moving the piston forward, engaging splitter gearing (2).

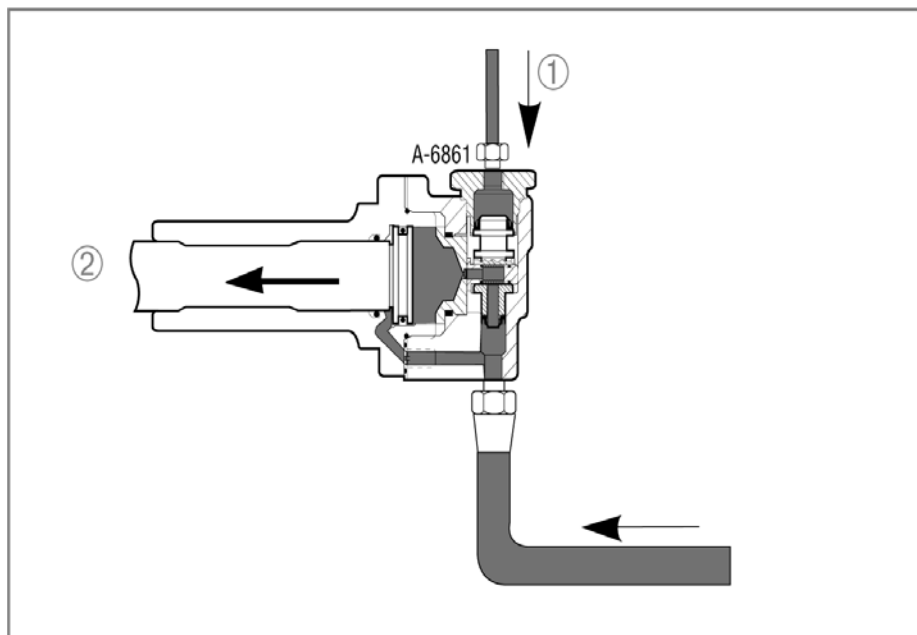

# System Components

## Spool Valve

The spool valve components shown are part of a self-contained valve assembly, part number A-6861.

The spool valve piston travel is approximately 1/2". When no air is supplied from the Roadranger valve to the valve spool left side (1), constant air from the filter/regulator (2) is supplied to the splitter cylinder piston front side moving the yoke bar rearward. Air is exhausted from the splitter cylinder rear (3) and from the breather situated on the valve assembly rear.

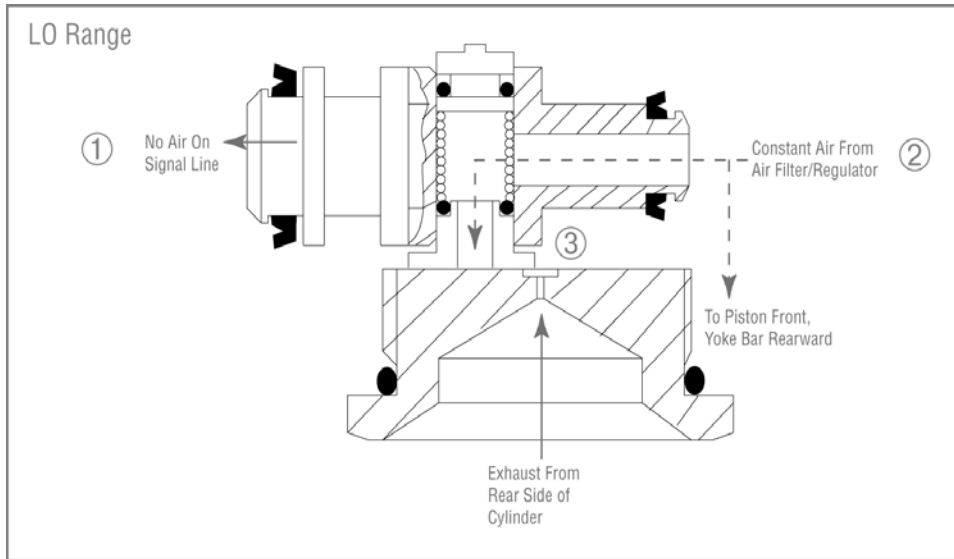

When air is supplied from the Roadranger valve to the valve spool left side (1), constant air from the filter/regulator (2) is supplied to the splitter cylinder piston rear side moving the yoke bar forward. Air is exhausted from the splitter cylinder front (3) and from the breather situated on the valve assembly rear.

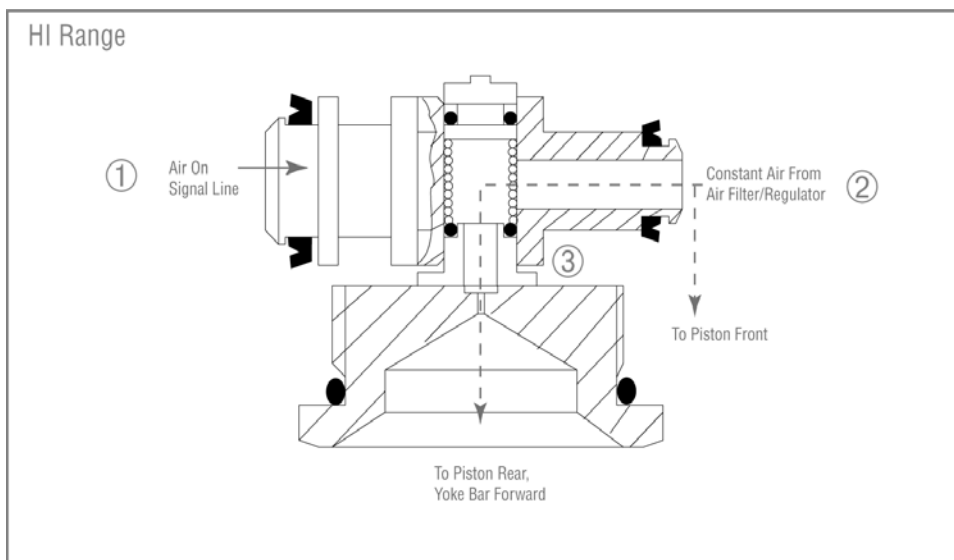

## RTL-xx710 Model Splitter Cylinder Assembly

**Odd Numbered Gear Positions (1, 3, 5, 7, 9)** With the Roadranger valve button in the forward position, air is supplied to the splitter cylinder cover port (1), moving the piston rearward, disengaging splitter gearing (2).

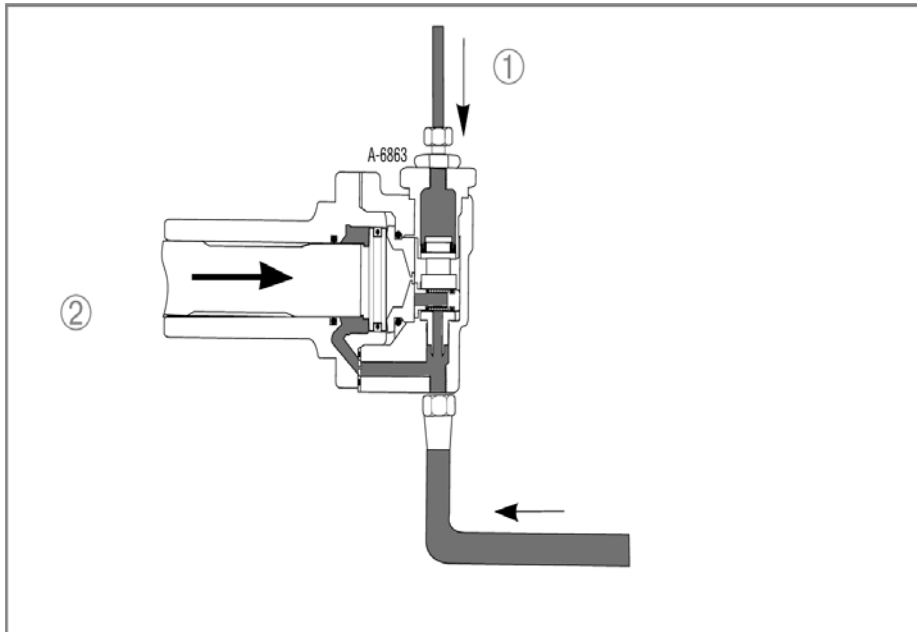

**Even Numbered Gear Positions (2, 4, 6, 8, 10)** With the Roadranger valve button in the rearward position, no air is supplied to the splitter cylinder cover port (1), moving the piston forward, engaging splitter gearing (2).

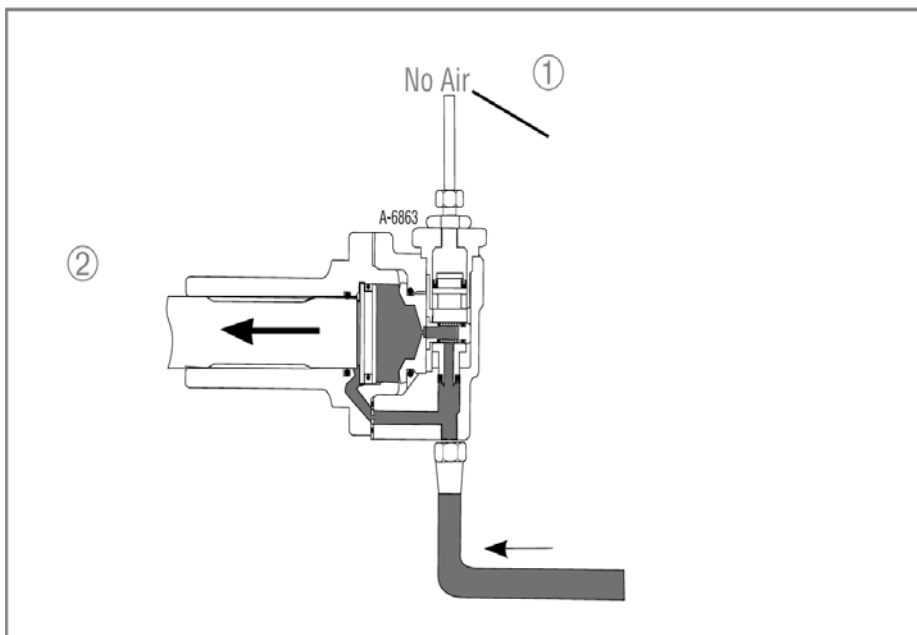

# System Components

## Spool Valve

The spool valve components shown are part of a self-contained valve assembly, part number A-6863.

The spool valve piston travel is approximately 1/2". When air is supplied from the Roadranger valve to the valve spool left side (1), constant air from the filter/regulator (2) is supplied to the splitter cylinder piston front side moving the yoke bar rearward. Air is exhausted from the splitter cylinder rear (3) and from the breather situated on the valve assembly rear.

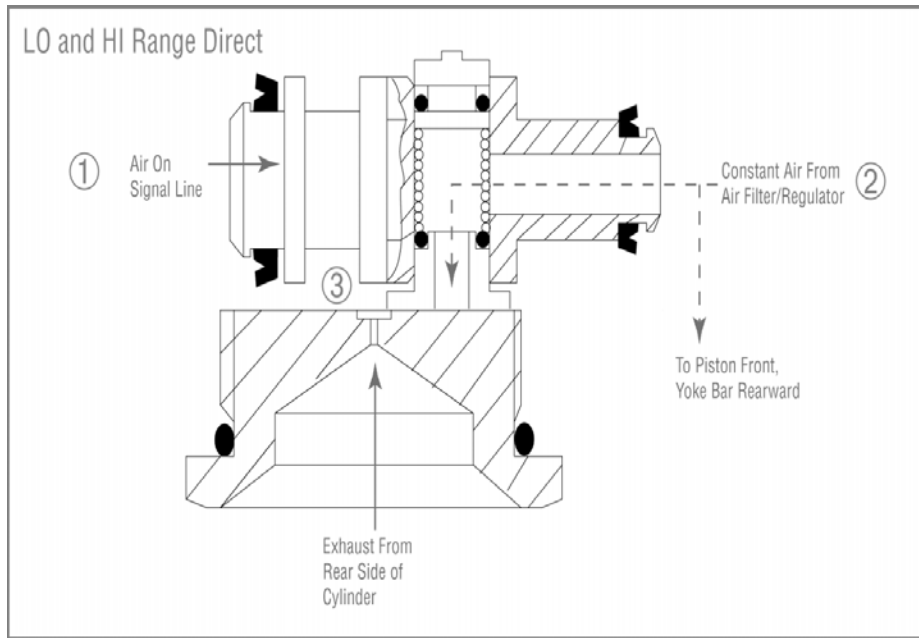

When no air is supplied from the Roadranger valve to the valve spool left side (1), constant air from the filter/regulator (2) is supplied to the splitter cylinder piston rear side moving the yoke bar forward. Air is exhausted from the splitter cylinder front (3) and from the breather situated on the valve assembly rear.

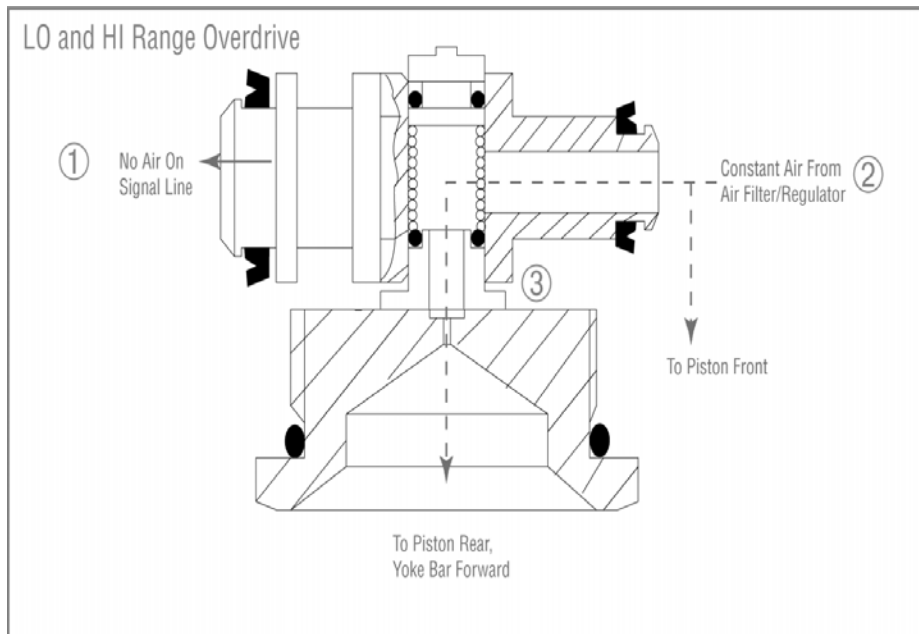

## RTLO-xx613 Model Splitter Cylinder Assembly

**LO Range or HI Range L** - With the splitter control button in the "rearward" position, no air is supplied to the splitter cylinder cover left port (1). The constant air from the air filter/regulator assembly (2) moves the splitter piston rearward, disengaging the front auxiliary gear (3).

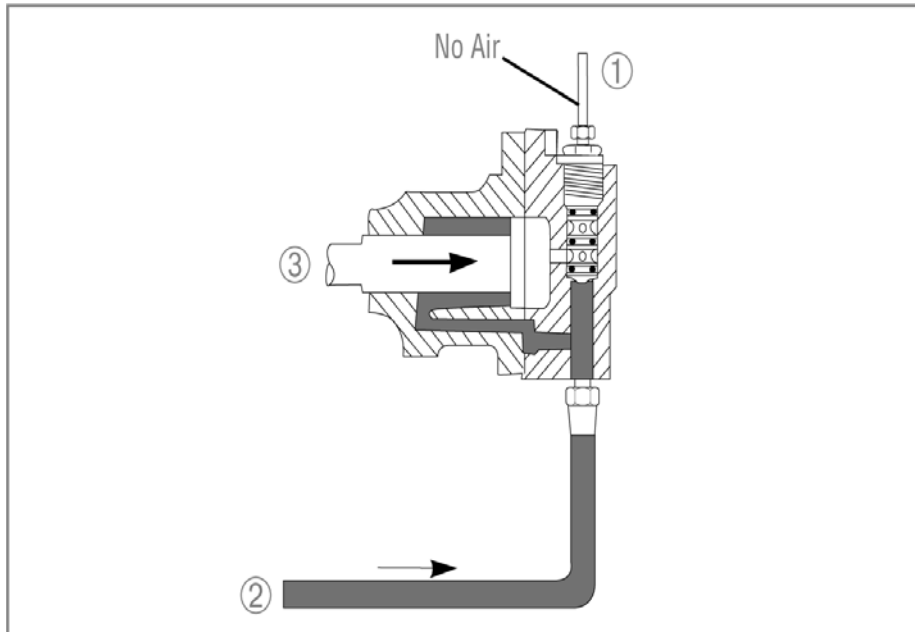

**HI Range H** - With the splitter control button in the "forward" position, air is supplied to the splitter cylinder cover left port (1), moving the splitter piston forward, engaging the front auxiliary drive gear (2).

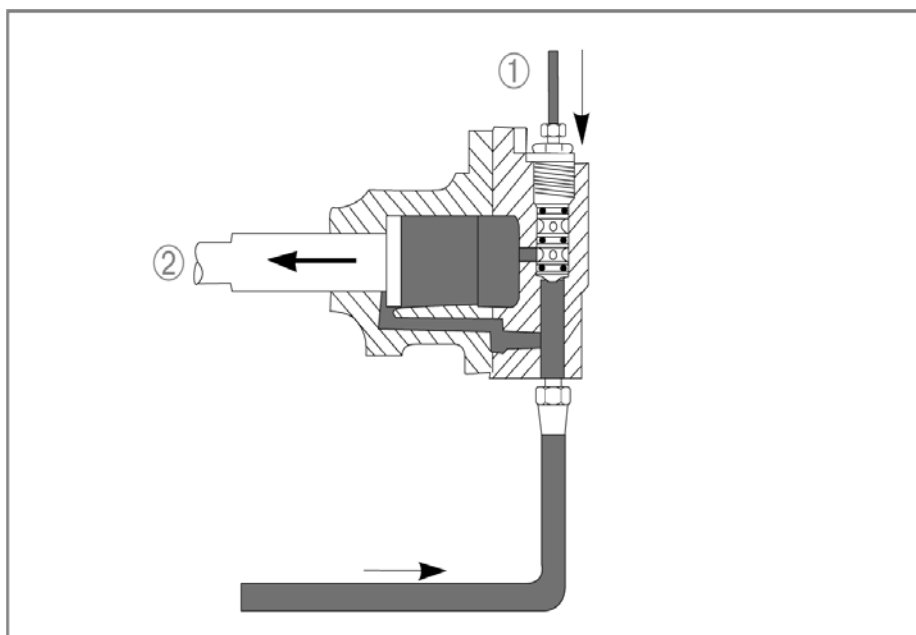



# System Components

## Insert Valve

The insert valve is a self-contained 1-13/16" valve assembly located in the intermediate shift cylinder cover. It cannot be disassembled except for the three (3) O-rings on the outer diameter. The O-rings provide a stationary seal and do not move in the cylinder.

Insert valve piston travel is only 1/32". When no air is applied to the valve piston top side through the signal line, constant air supplied from the air filter/regulator moves the yoke bar rearward to engage the rear auxiliary drive gear (LO and HI range L), while air is exhausted out the insert valve.

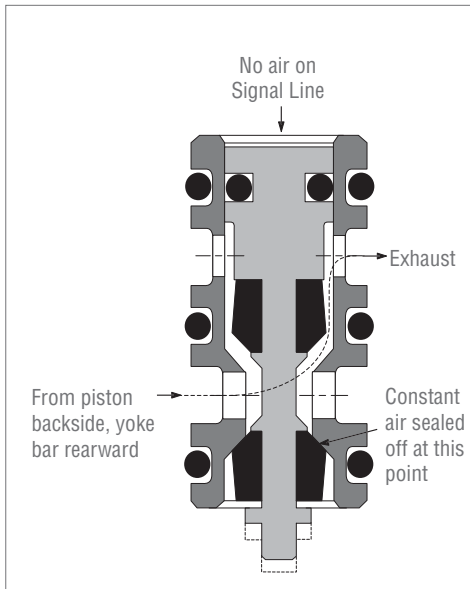

When air is applied to the valve piston top side, the piston moves down passing air through the insert valve bottom to the cylinder piston front and backside, moving the yoke bar forward to engage the front auxiliary drive gear (HI range H).

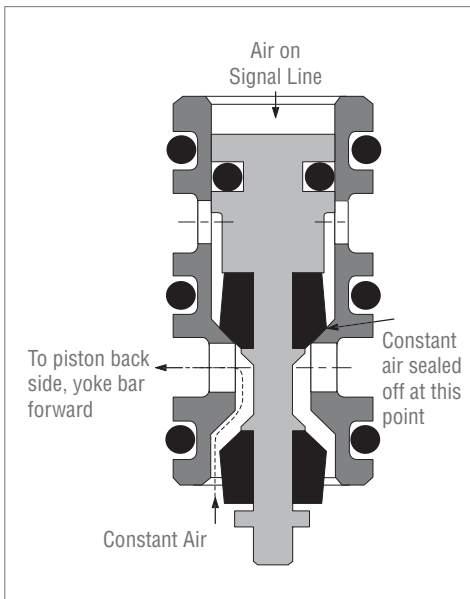

## RTLO-xx713 Model Splitter Cylinder Assembly

**LO Range or HI Range L** - With the splitter control button in the "rearward" position, no air is supplied to the splitter cylinder cover top port (1). The constant air from the air filter/regulator assembly (2) moves the splitter piston forward, disengaging the rear auxiliary drive gear (3).

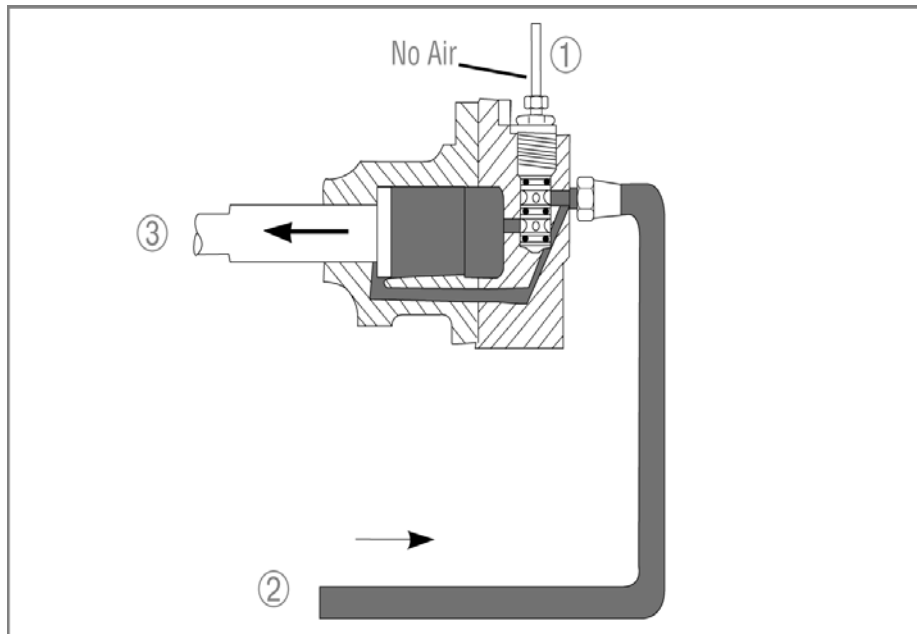

**HI Range H** - With the splitter control button in the "forward" position, air is supplied to the splitter cylinder cover top port (1), moving the splitter piston rearward, engaging the rear auxiliary drive gear (2).

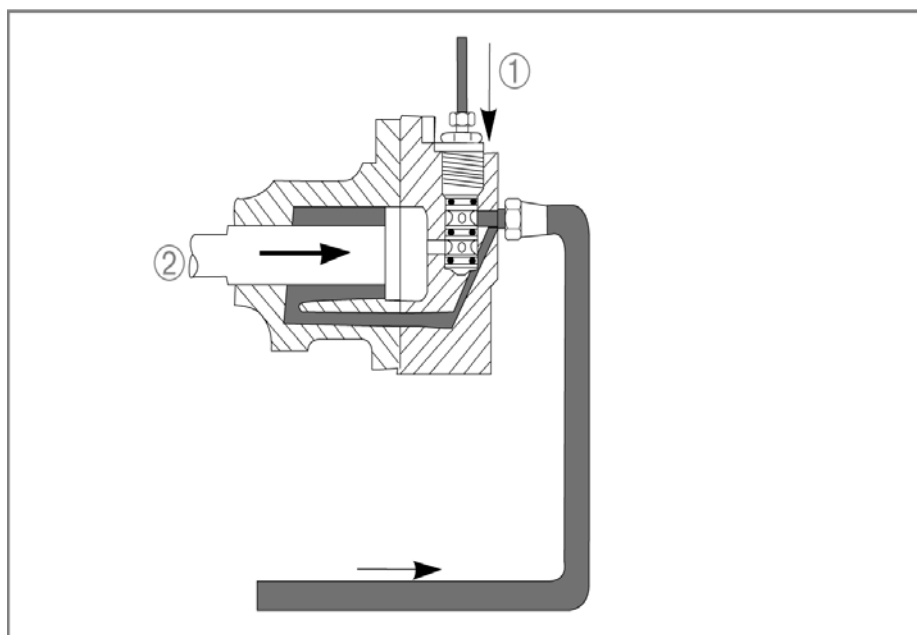

# System Components

## Insert Valve

The insert valve is a self-contained 1-13/16" valve assembly located in the intermediate shift cylinder cover. It cannot be disassembled except for the three (3) O-rings on the outer diameter. The O-rings provide a stationary seal and do not move in the cylinder.

Insert valve piston travel is only 1/32". When no air is applied to the valve piston top side, constant air supplied from the air filter/regulator passes freely through the insert valve and to the cylinder piston backside, moving the yoke bar forward to disengage the rear auxiliary drive gear (LO range and HI range L).

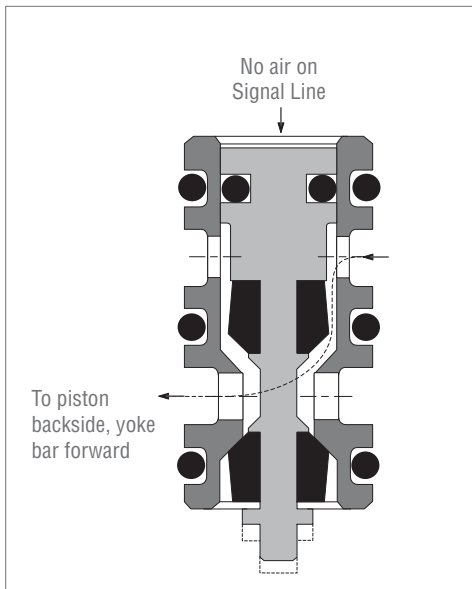

When air is applied to the valve piston top side through the signal line, the piston moves down to cut off air supplied to the cylinder piston backside. This air is exhausted out the cover bottom port as constant air supplied from the regulator is directed to the cylinder piston front side, moving the yoke bar rearward to engage the rear auxiliary drive gear (HI range H).

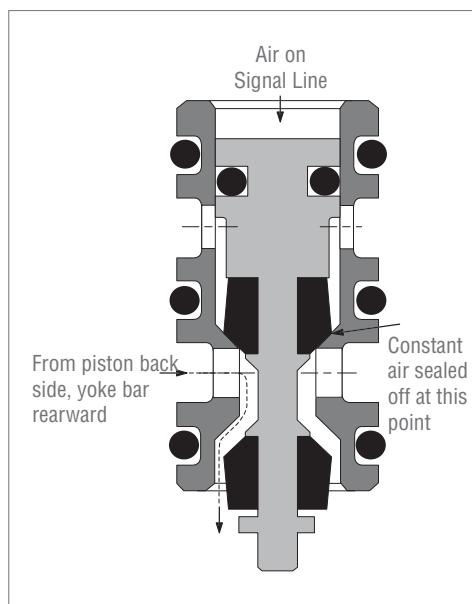

## RTLO-xx913 Model Splitter Cylinder Assembly

**LO Range or HI Range Low Split** - With the splitter control button in the "rearward" position, no air is supplied to the splitter cylinder cover top port (1). The constant air from the air filter/regulator assembly (2) moves the the splitter piston rearward, disengaging the rear auxiliary drive gear (3).

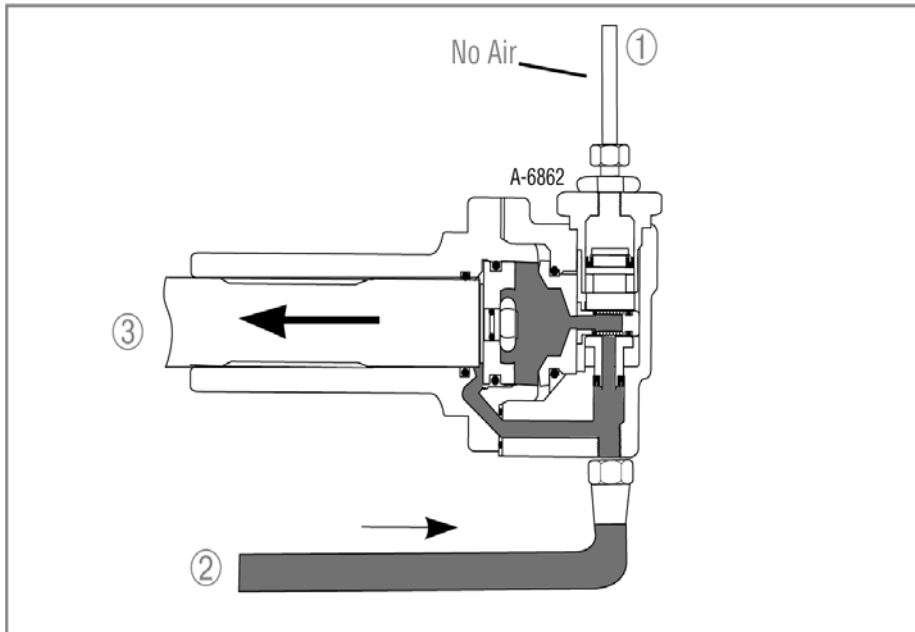

**HI Range High Split** - With the splitter control button in the "forward" position, air is supplied to the splitter cylinder cover top port (1), moving the the splitter piston forward, engaging the rear auxiliary drive gear (2).

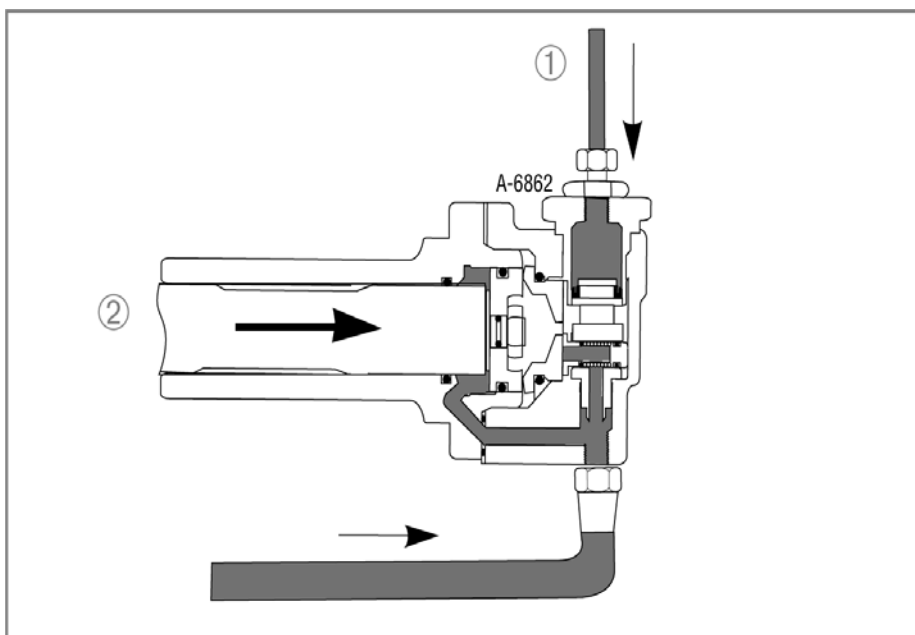

# System Components

## Spool Valve

The spool valve components shown are part of a self-contained valve assembly, part number A-6862.

The spool valve piston travel is approximately 1/2". When no air is supplied from the Roadranger valve to the valve spool left side (1), constant air from the filter/regulator (2) is supplied to the splitter cylinder piston rear side moving the yoke bar forward.

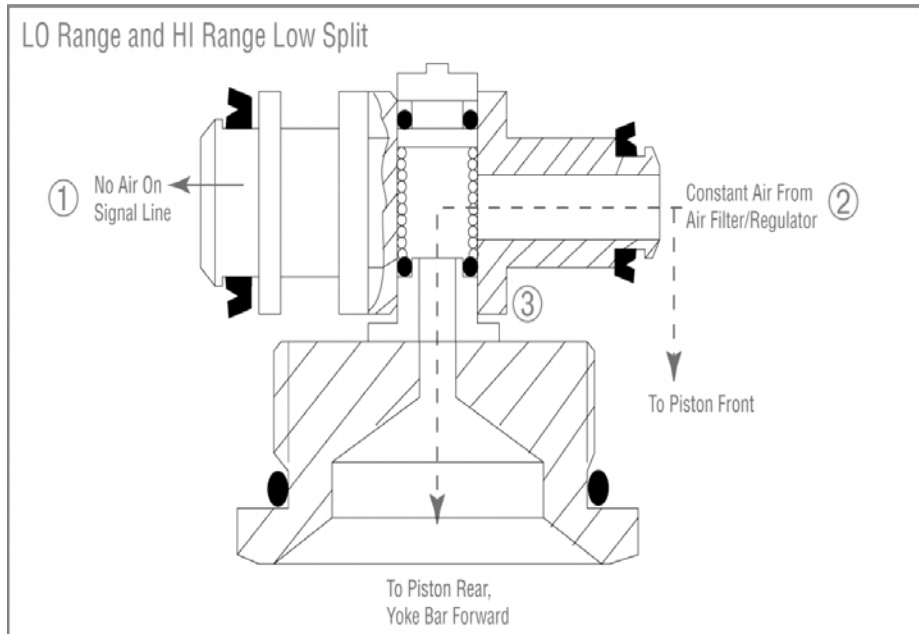

When air is supplied from the Roadranger valve to the valve spool left side (1), constant air from the filter/regulator (2) is supplied to the splitter cylinder piston front side moving the yoke bar rearward. Air is exhausted from the splitter cylinder rear (3) and from the breather situated on the valve assembly rear.

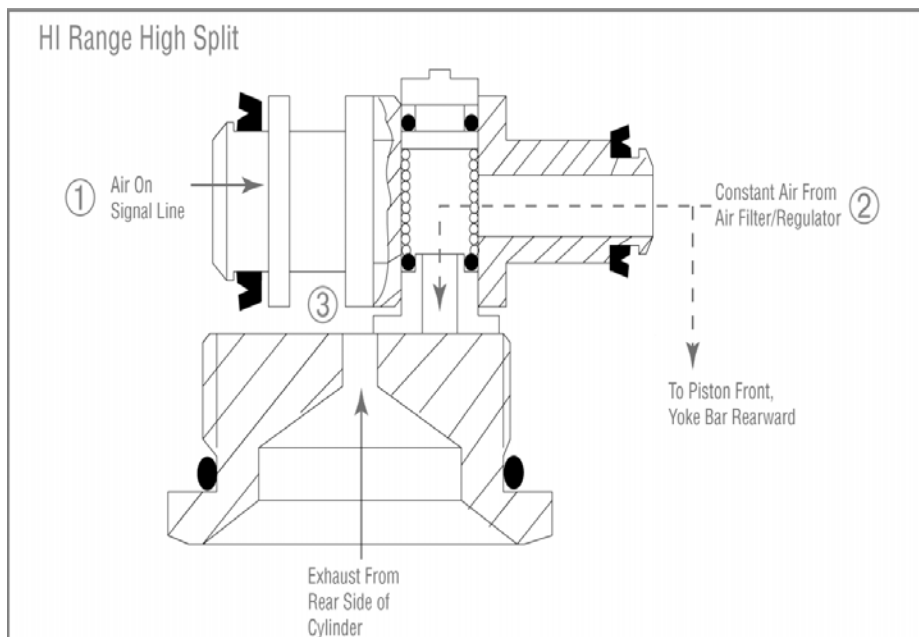

## RTO-15618 and RTLO-xx618 Model Splitter Cylinder Assembly

**LO or HI Range L** - With the splitter control button in the "rearward" position, no air is supplied to the splitter cylinder cover left port (1). The constant air from the air filter/regulator assembly (2) moves the splitter piston rearward, disengaging the front auxiliary drive gear (3).

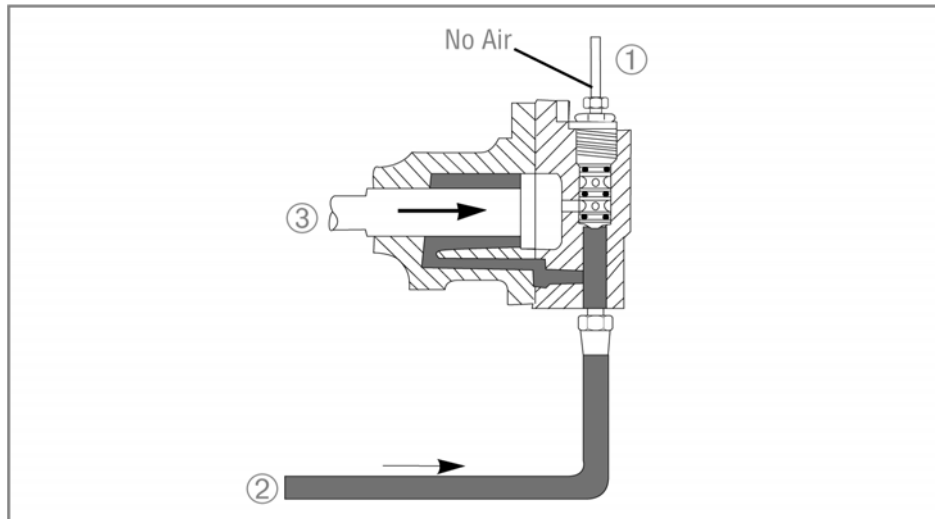

**LO or HI Range H** - With the splitter control button in the "forward" position, air is supplied to the splitter cylinder cover left port (1), moving the splitter piston forward, engaging the front auxiliary drive gear (2).

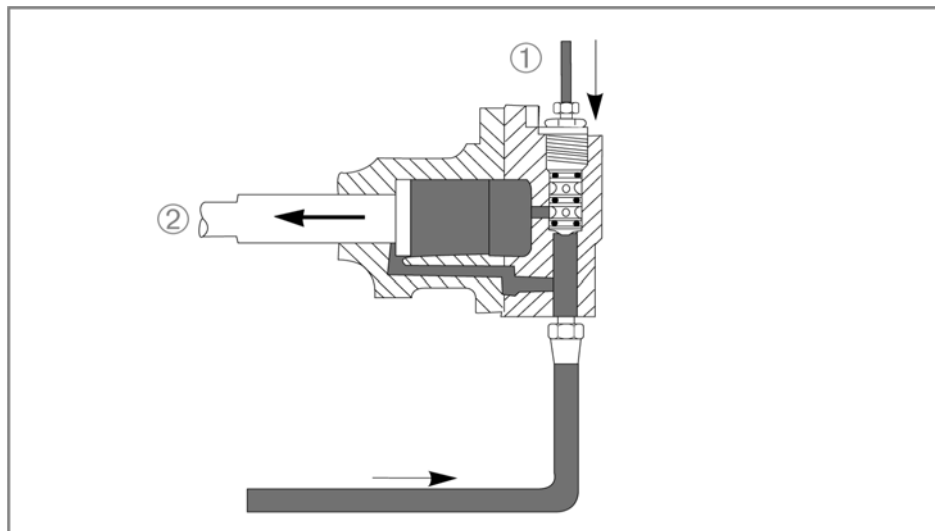

# System Components

## Insert Valve

The insert valve is a self-contained 1-13/16" valve assembly located in the intermediate shift cylinder cover. It cannot be disassembled except for the three (3) O-rings on the outer diameter. The O-rings provide a stationary seal and do not move in the cylinder.

Insert valve piston travel is only 1/32". When no air is applied to the valve piston top side through the signal line, constant air supplied from the air filter/regulator moves the yoke bar rearward to engage the rear auxiliary drive gear (LO and HI range L), while air is exhausted out the insert valve.

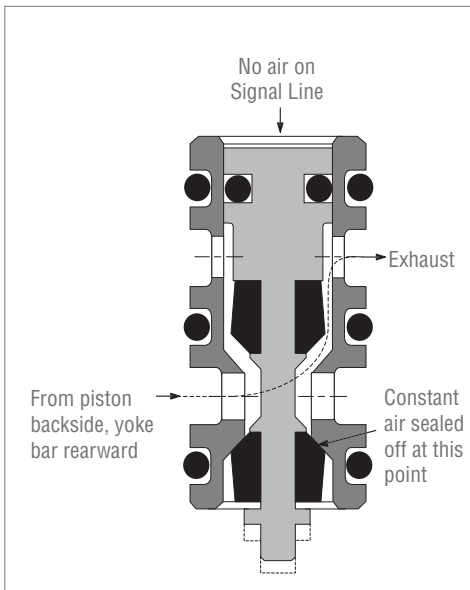

When air is applied to the valve piston top side, the piston moves down passing air through the insert valve bottom to the cylinder piston front and backside, moving the yoke bar forward to engage the front auxiliary drive gear (LO range and HI range H).

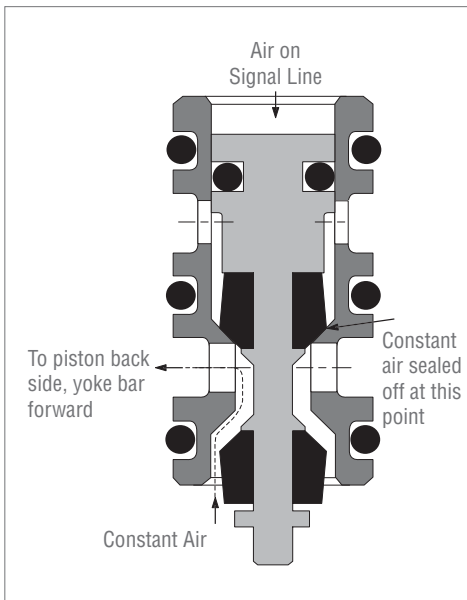

## RTLO-xx718 Model Splitter Cylinder Assembly

**LO Range or HI Range L** - With the splitter control button in the "rearward" position, no air is supplied to the splitter cylinder cover top port (1). The constant air from the air filter/regulator assembly (2) moves the the splitter piston forward, disengaging the rear auxiliary drive gear (3).

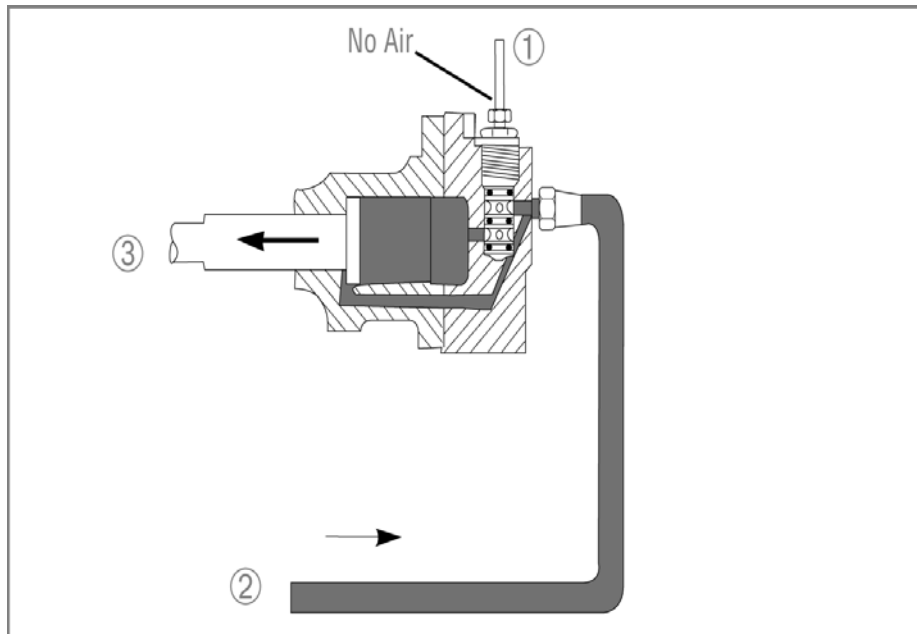

**LO Range or HI Range H** - With the splitter control button in the "forward" position, air is supplied to the splitter cylinder cover top port (1), moving the the splitter piston rearward, engaging the rear auxiliary drive gear (2).

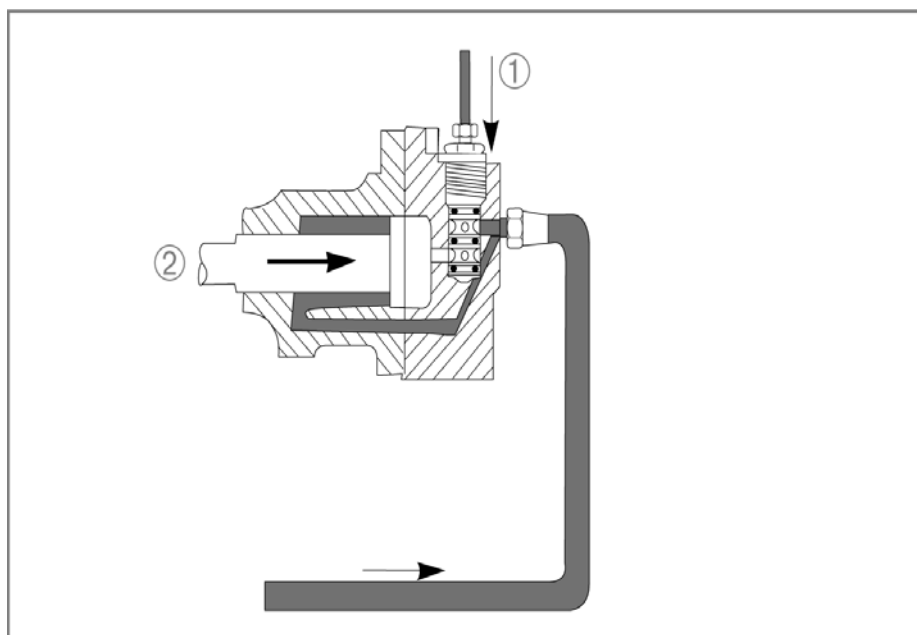



# System Components

## Insert Valve

The insert valve is a self-contained 1-13/16" valve assembly located in the intermediate shift cylinder cover. It cannot be disassembled except for the three (3) O-rings on the outer diameter. The O-rings provide a stationary seal and do not move in the cylinder.

Insert valve piston travel is only 1/32". When no air is applied to the valve piston top side, constant air supplied from the air filter/regulator passes freely through the insert valve and to the cylinder piston backside, moving the yoke bar forward to disengage the rear auxiliary drive gear (LO range and HI range L).

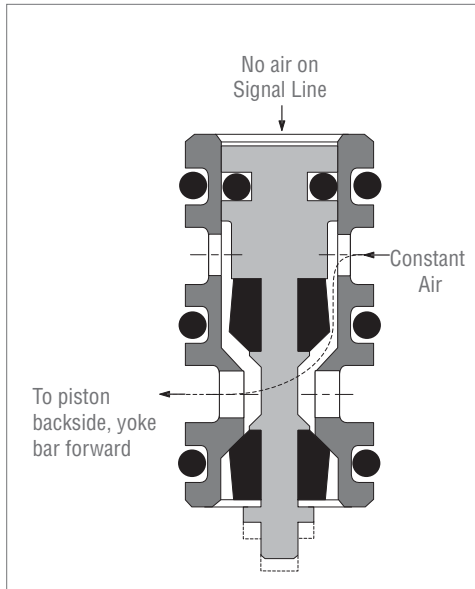

When air is applied to the valve piston top side through the signal line, the piston moves down to cut off air supplied to the cylinder piston backside. This air is exhausted out the cover bottom port as constant air supplied from the regulator is directed to the cylinder piston front side, moving the yoke bar rearward to engage the rear auxiliary drive gear (LO range and HI range H).

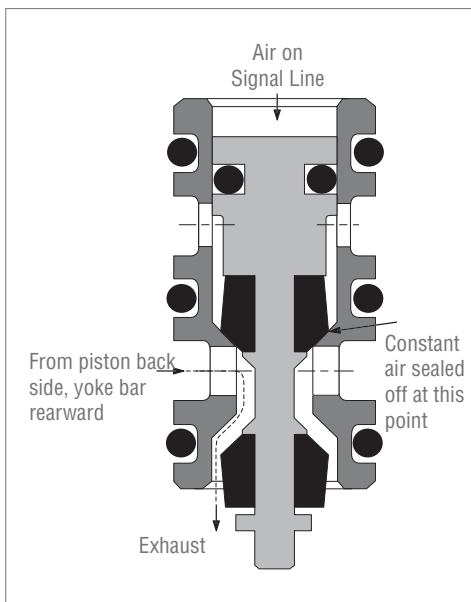

## RTLO-xx918 Model Splitter Cylinder Assembly

**LO Range or HI Range Low Split** - With the splitter control button in the "rearward" position, no air is supplied to the splitter cylinder cover top port (1). The constant air from the air filter/regulator assembly (2) moves the splitter piston forward, disengaging the rear auxiliary drive gear (3).

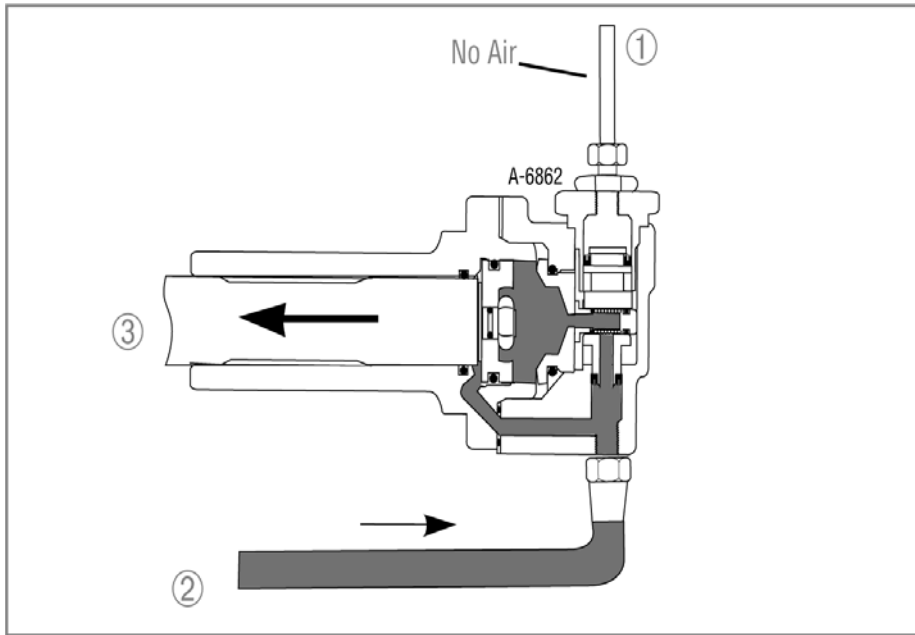

**LO Range or HI Range High Split** - With the splitter control button in the "forward" position, air is supplied to the splitter cylinder cover top port (1), moving the splitter piston rearward, engaging the rear auxiliary drive gear (2).

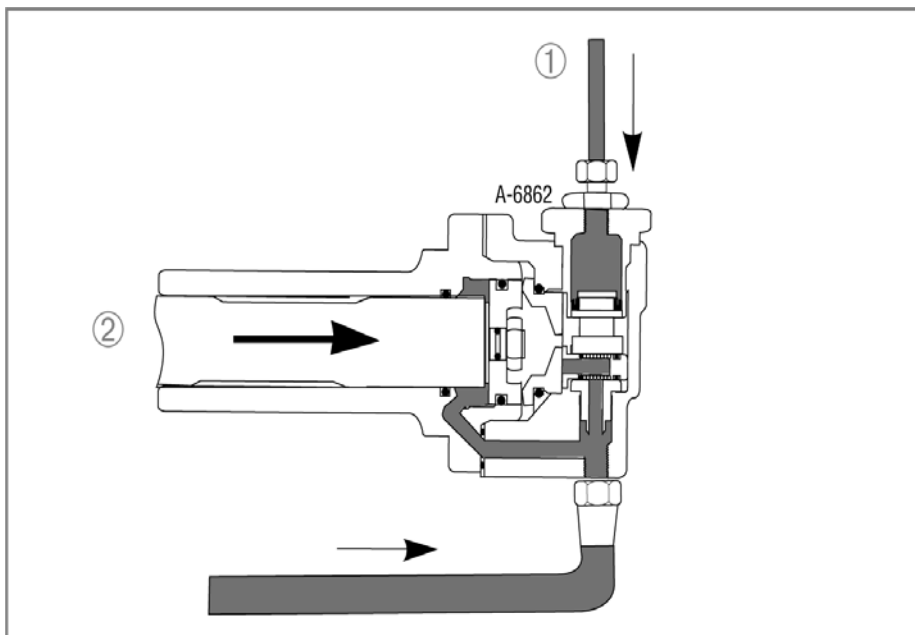

System Components

# System Components

## Spool Valve

The spool valve components shown are part of a self-contained valve assembly, part number A-6862.

The spool valve piston travel is approximately 1/2". When no air is supplied from the Roadranger valve to the valve spool left side (1), constant air from the filter/regulator (2) is supplied to the splitter cylinder piston rear side moving the yoke bar forward. Air is exhausted from the splitter cylinder front (3) and from the breather situated on the valve assembly rear.

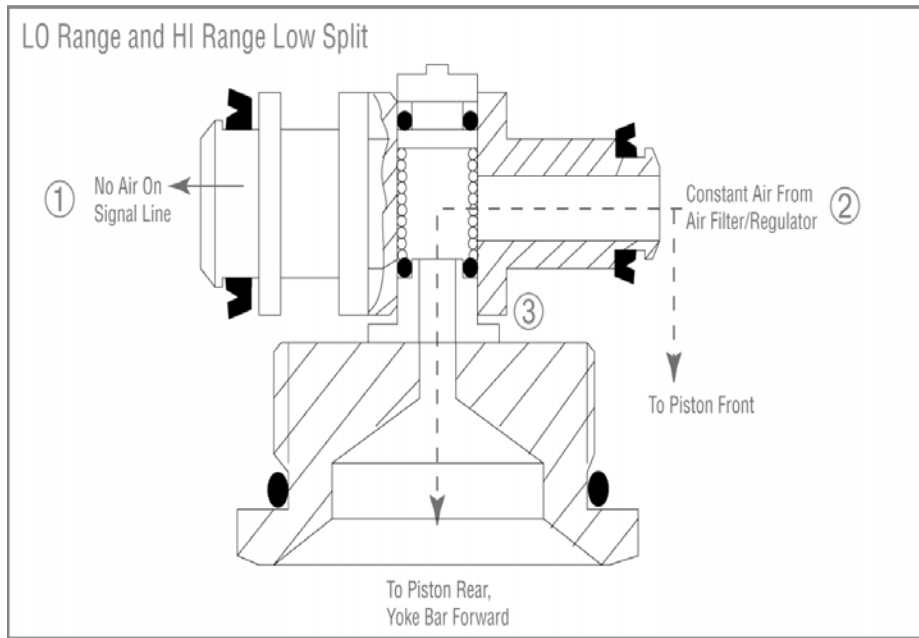

When air is supplied from the Roadranger valve to the valve spool left side (1), constant air from the filter/regulator (2) is supplied to the splitter cylinder piston front side moving the yoke bar rearward. Air is exhausted from the splitter cylinder rear (3) and from the breather situated on the valve assembly rear.

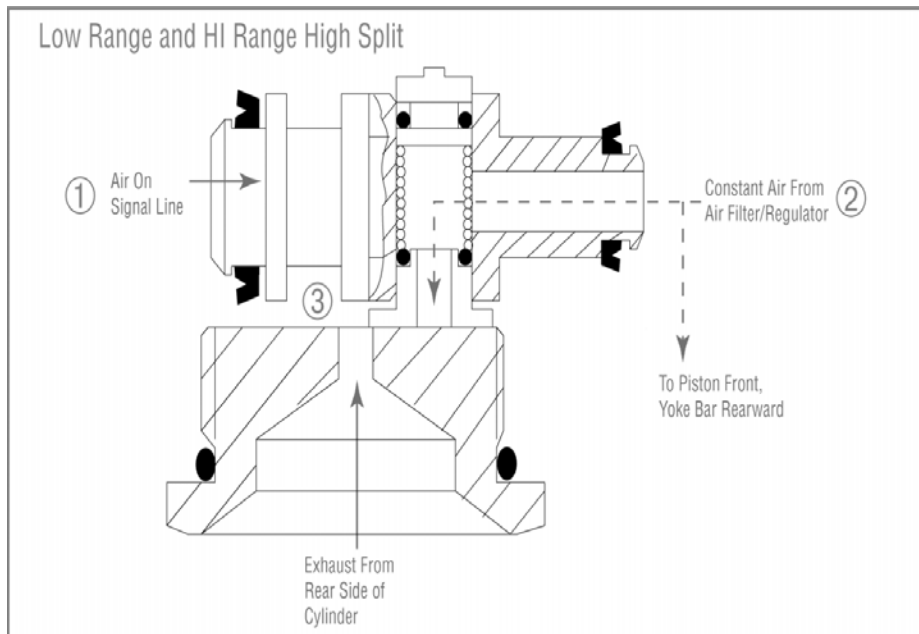

Basic Air System Drawings - 6610, 8609, and 6609

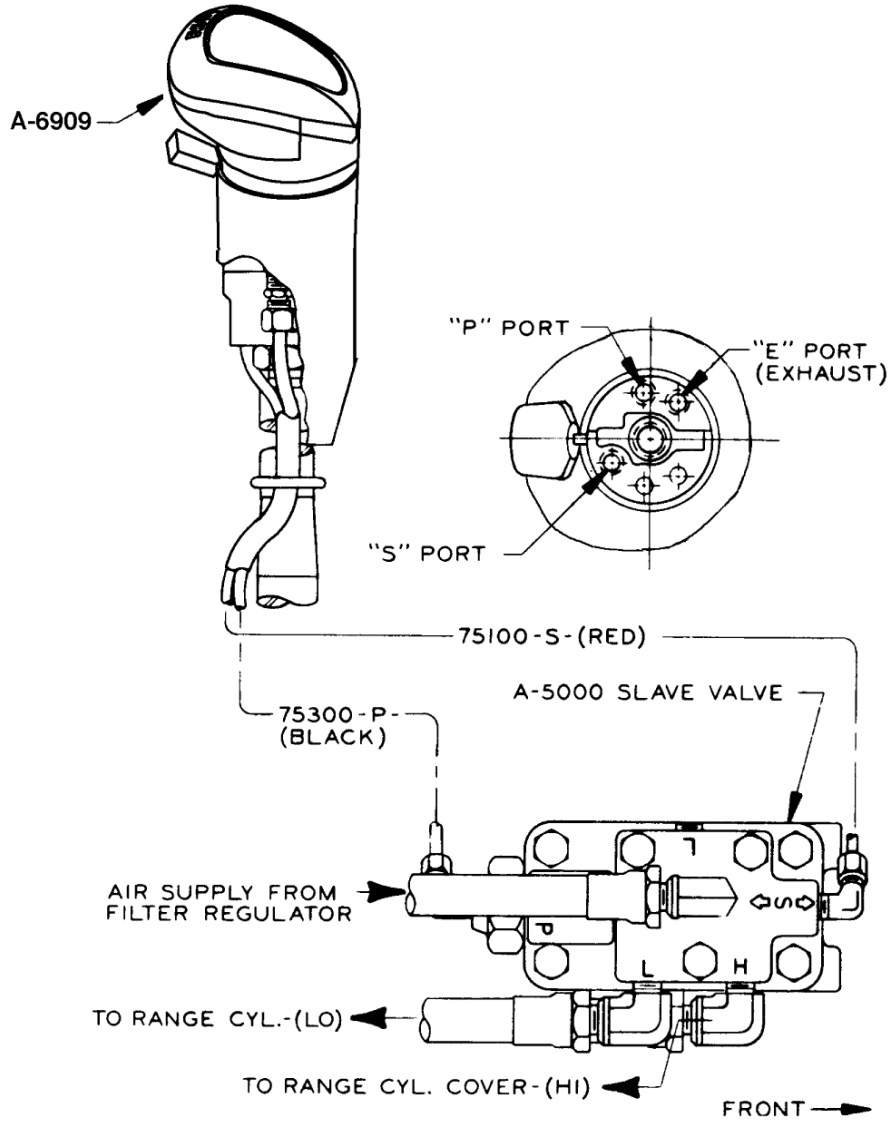

Engineering Reference Drawings

# Engineering Reference Drawings

## Basic Air System Drawings - 07L, 08, 08L, 09, and 10-Speed Models

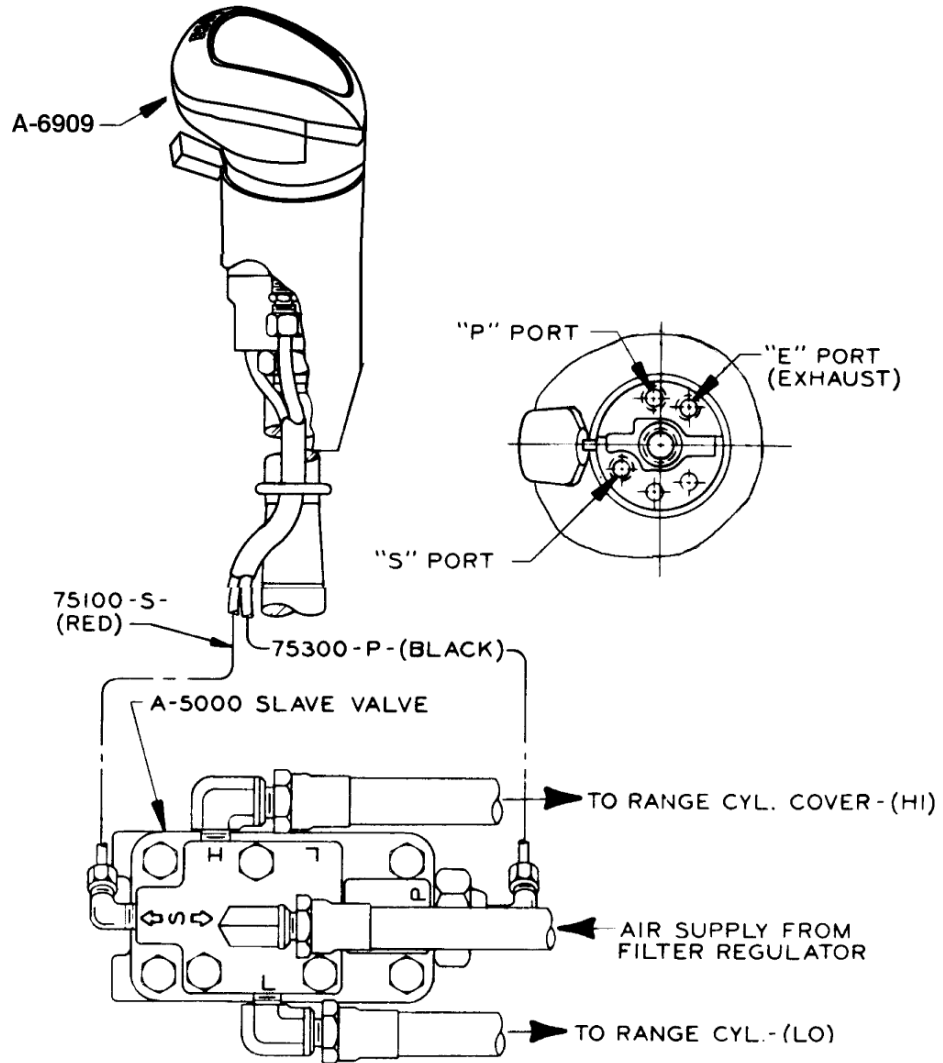

Basic Air System Drawings - 07LL, 08LL, and 15 Speed Models

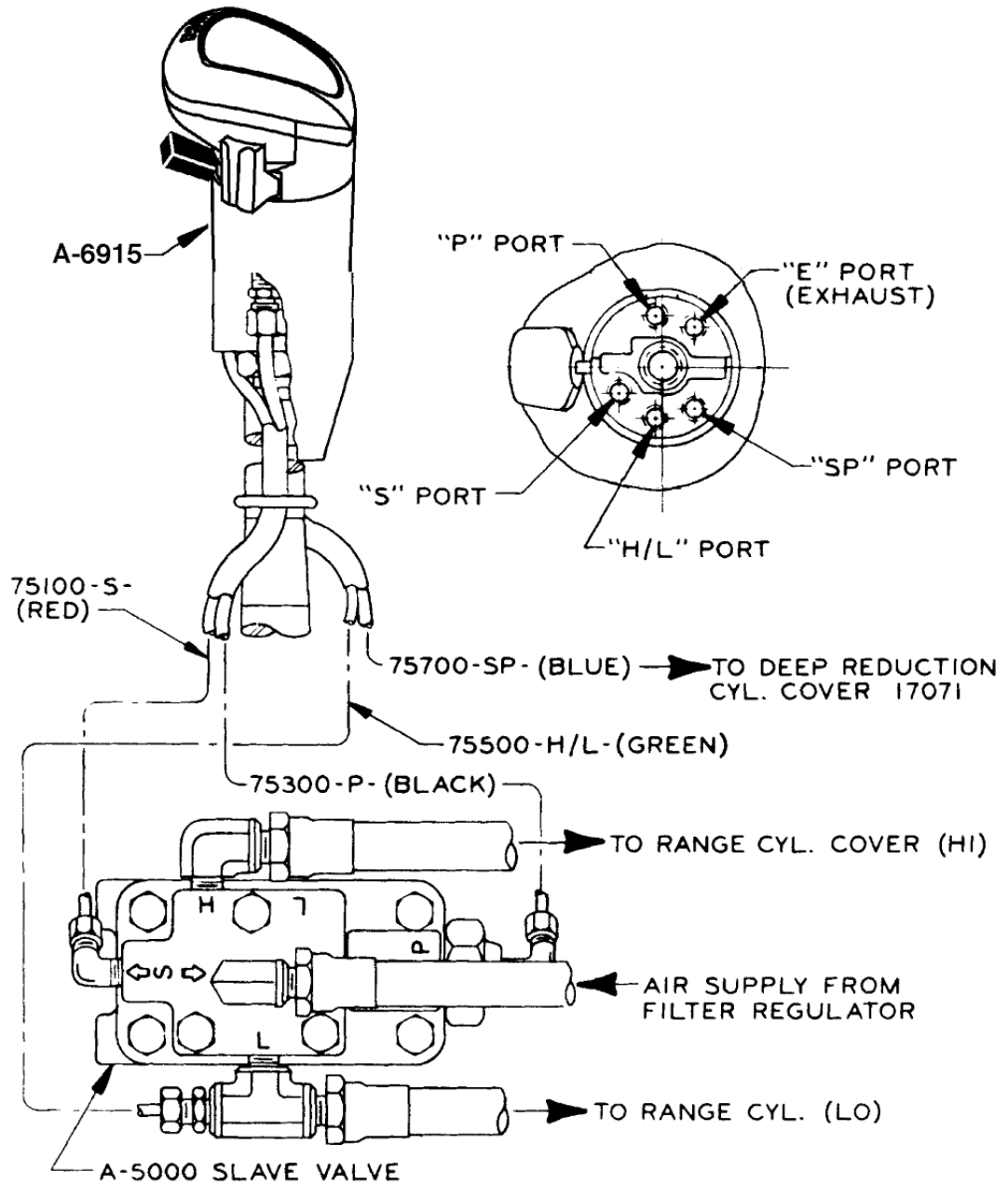

Engineering Reference Drawings

# Engineering Reference Drawings

## Basic Air System Drawings - 707LL, 7/908LL, 7/909LL, and 7/915 Speed Models

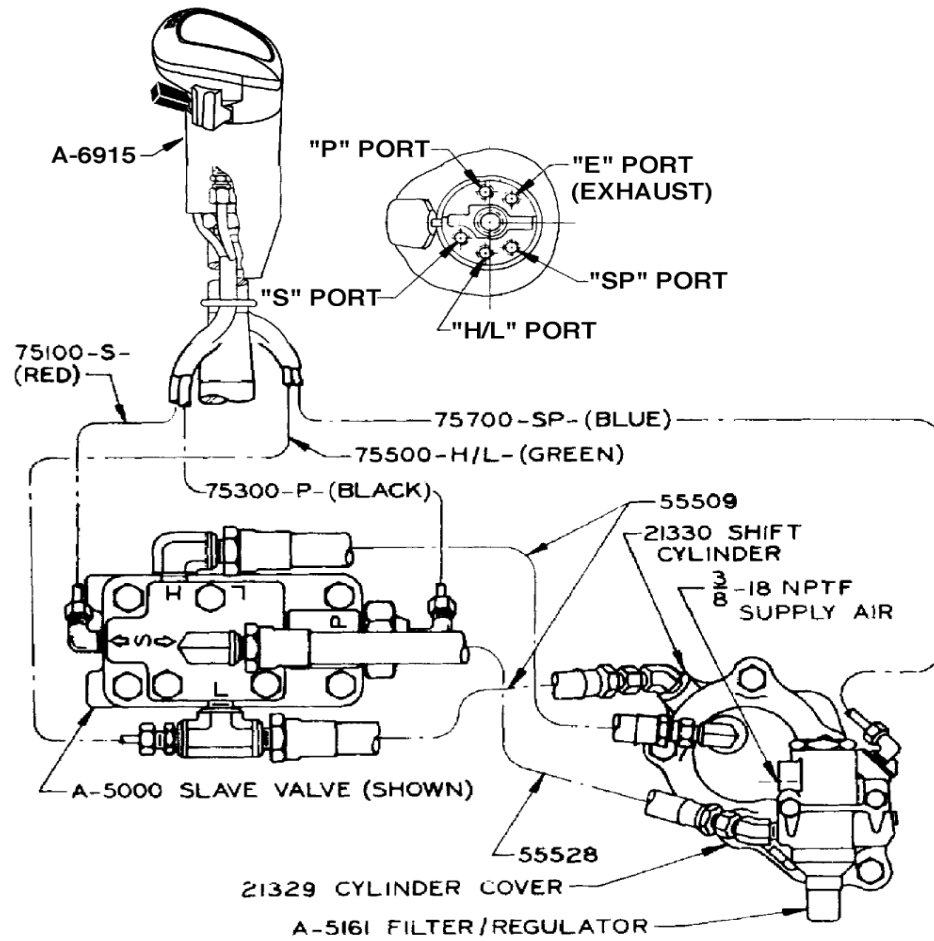

Basic Air System Drawings - 11613, 14613, and 15613 Speed Models

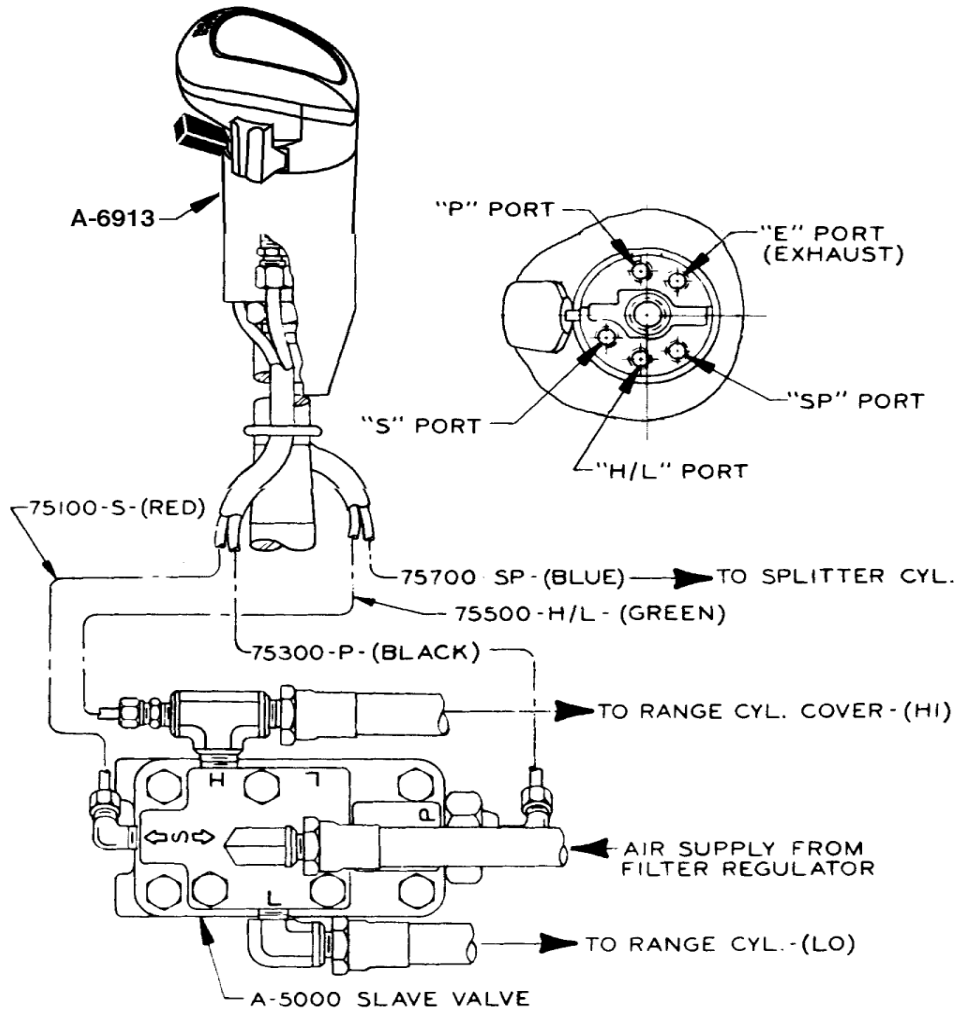

Engineering Reference Drawings



# Engineering Reference Drawings

## Basic Air System Drawings - 6613, and 7608LL Speed Models

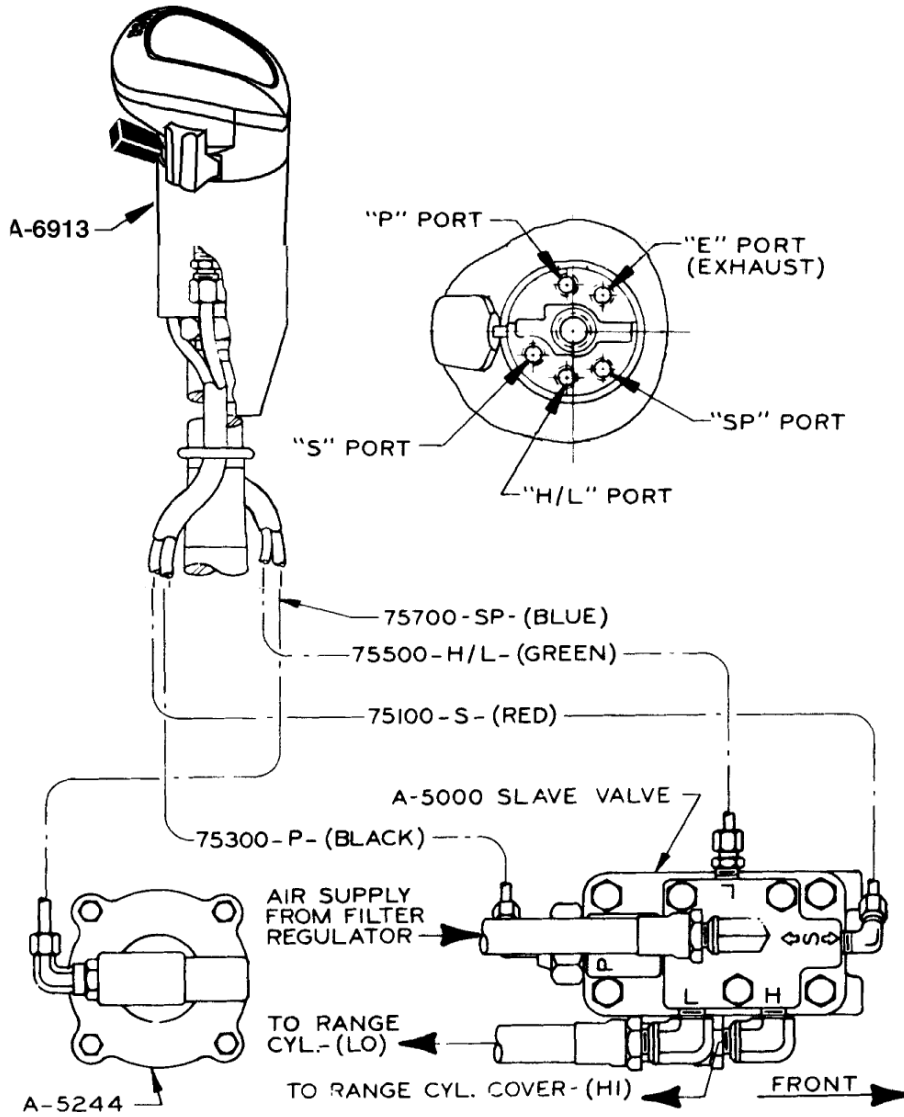

Basic Air System Drawings - 18 Speed Models Left-Hand Drive

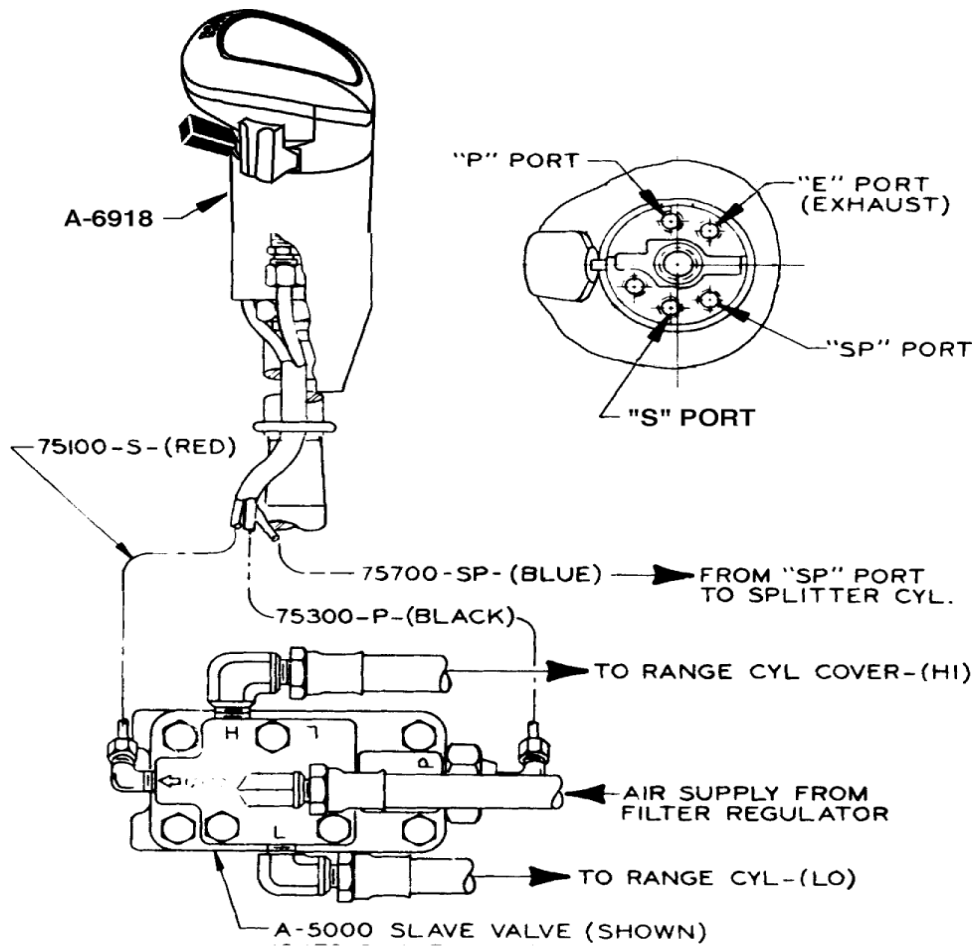

Engineering Reference Drawings

# Engineering Reference Drawings

## Basic Air System Drawings - 18 Speed Right-Hand Drive

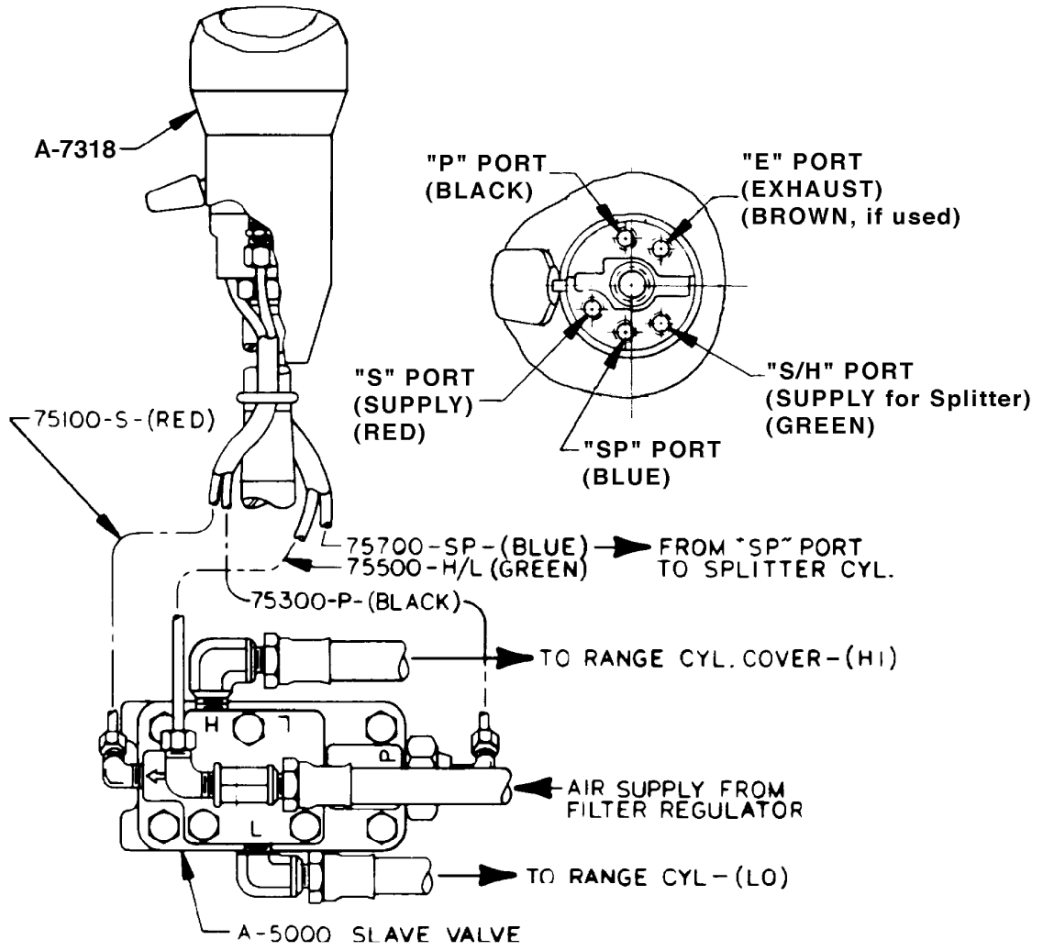



Copyright Eaton Corporation, 2012. Eaton hereby grant their customers, vendors, or distributors permission to freely copy, reproduce and/or distribute this document in printed format. It may be copied only in its entirety without any changes or modifications. THIS INFORMATION IS NOT INTENDED FOR SALE OR RESALE, AND THIS NOTICE MUST REMAIN ON ALL COPIES.

**Note:** Features and specifications listed in this document are subject to change without notice and represent the maximum capabilities of the software and products with all options installed. Although every attempt has been made to ensure the accuracy of information contained within, Eaton makes no representation about the completeness, correctness or accuracy and assumes no responsibility for any errors or omissions. Features and functionality may vary depending on selected options.

**For spec'ing or service assistance, call 1-800-826-HELP (4357) or visit [www.eaton.com/roadranger](http://www.eaton.com/roadranger). In Mexico, call 001-800-826-4357.**

Roadranger: Eaton and trusted partners providing the best products and services in the industry, ensuring more time on the road.

**Eaton Corporation**

Vehicle Group  
P.O. Box 4013  
Kalamazoo, MI 49003 USA  
800-826-HELP (4357)  
[www.eaton.com/roadranger](http://www.eaton.com/roadranger)

Printed in USA

For parts or service call us  
Pro Gear & Transmission, Inc.



**1 (877) 776-4600**

**(407) 872-1901**

**parts@eprogear.com**

**906 W. Gore St.**

**Orlando, FL 32805**

