

# Fuller Automated Transmissions TRSM0011

October 2007

RTLO-11118A-MT  
RTLO-9118A-MT



*Powering Business Worldwide*

BACKED BY  
**Roadranger**  
SUPPORT

For parts or service call us  
Pro Gear & Transmission, Inc.



**1 (877) 776-4600**

**(407) 872-1901**

**parts@eprogear.com**

**906 W. Gore St.**

**Orlando, FL 32805**



# **TABLE OF CONTENTS**

---

**FOREWORD**

**MODEL DESIGNATIONS AND SPECIFICATIONS**

**LUBRICATION**

**OPERATION**

**POWER FLOW**

**TIMING**

**TORQUE RECOMMENDATIONS**

**TOOL REFERENCE**

**LUBRICATION CHANGE PROCEDURE**

**HYDRAULIC SYSTEM FLUSH PROCEDURE**

**HOW TO CHANGE OIL SUMP PAN/STRAINER OIL FILTER**

**TRANSMISSION OIL FILTER CHANGE PROCEDURE**

**PREVENTIVE MAINTENANCE CHECKS**

**PRECAUTIONS**

DISASSEMBLY

INSPECTION

REASSEMBLY

**CHANGING INPUT SHAFT**

**AIR SYSTEM**

RANGE SHIFT AIR SYSTEM

SPLITTER SHIFT AIR SYSTEM

**AIR SYSTEM SCHEMATICS**

**DISASSEMBLY SHIFTING CONTROLS**

**DISASSEMBLY AND REASSEMBLY SHIFT BAR HOUSING**

**REMOVAL - OUTPUT YOKE, AUXILIARY SECTION AND TORQUE CONVERTER HOUSING**

**DISASSEMBLY - AUXILIARY SECTION**

**REASSEMBLY - AUXILIARY SECTION**

**DISASSEMBLY - FRONT SECTION**

**REASSEMBLY - FRONT SECTION**

**INSTALLATION - TORQUE CONVERTER HOUSING,**

**AUXILIARY SECTION AND OUTPUT YOKE**

**INSTALLATION - SHIFTING CONTROLS**

**SHIMMING CHART**

# FOREWORD

---

This manual is designed to provide detailed information necessary to service and repair the Fuller Transmissions listed on the cover.

As outlined in the Table of Contents, the manual is divided into 3 main sections:

- a. Technical information and reference
- b. Removal, disassembly, reassembly and installation

The format of the manual is designed to be followed in its entirety if complete disassembly and reassembly of the transmission is necessary. But if only one component of the transmission needs to be repaired, refer to the Table of Contents for the page numbers showing that component. For example, if you need to work on the Shifting Controls, you will find instructions for removal, disassembly and

reassembly on page 35. Instructions for installation are on page 111. Service Manuals, Illustrated Parts Lists, Drivers Instructions, and other forms of product service information for these and other Fuller Transmissions are available upon request. You may also obtain Service Bulletins, detailing information on product improvements, repair procedures and other service-related subjects by writing to the following address:

EATON CORPORATION  
TRANSMISSION DIVISION  
Technical Service Department  
P.O. Box 4013  
Kalamazoo, Michigan 49003  
(616) 342-3344

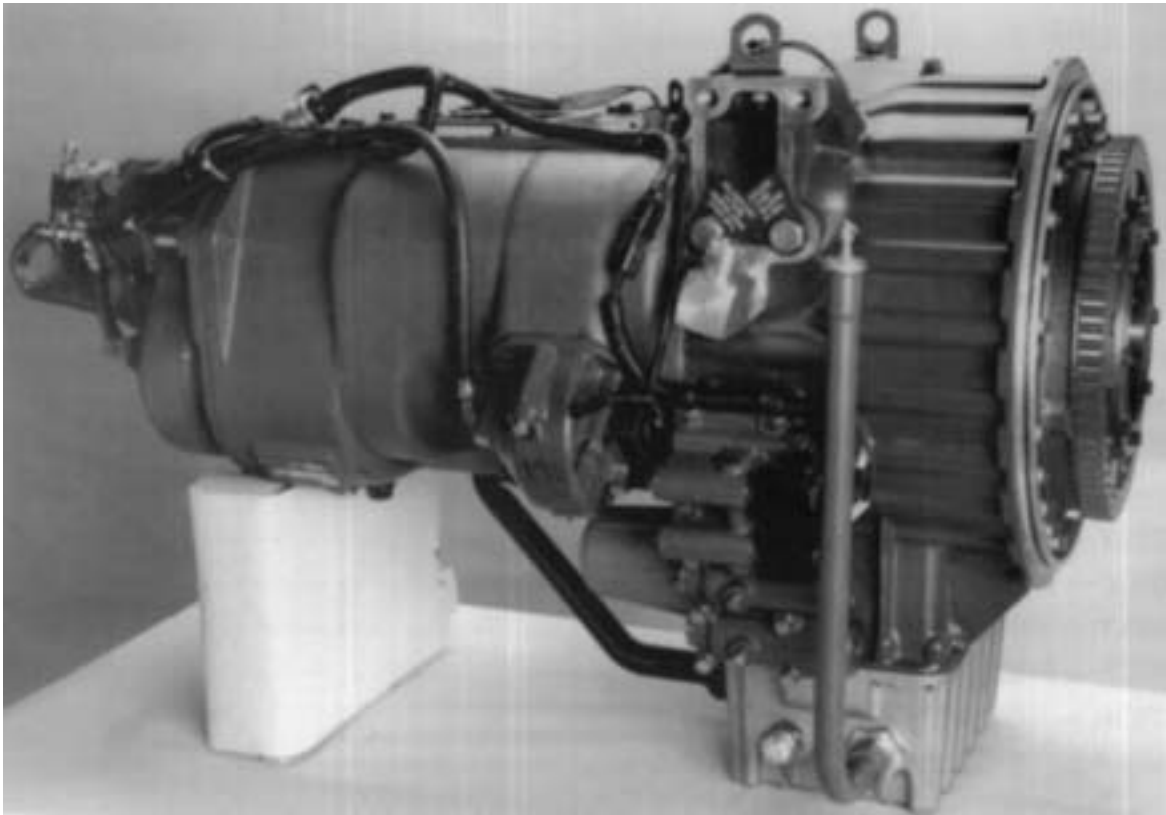

Every effort has been made to ensure the accuracy of all information in this brochure. **However, Eaton Transmission Division makes no expressed or implied warranty or representation based on the enclosed information.** Any errors or omissions may be reported to Training and Publications, Eaton Transmission Division, PO. Box 4013, Kalamazoo, MI 49003.

# MODEL DESIGNATIONS AND SPECIFICATIONS

## Nomenclature:

# RTLO-9118MT

### Letter Designations

Roadranger® \_\_\_\_\_  
 Twin Countershaft \_\_\_\_\_  
 Low Inertia Mainshaft \_\_\_\_\_  
 Overdrive \_\_\_\_\_

Torque Converter \_\_\_\_\_  
 Manual \_\_\_\_\_  
 Forward Speeds \_\_\_\_\_  
 Multi-Mesh Gearing \_\_\_\_\_  
 x 100 = Nominal Torque Capacity \_\_\_\_\_

**IMPORTANT:** All Fuller Transmissions are identified by model and serial number. This information is stamped on the transmission identification tag and affixed to the case. DO NOT REMOVE OR DESTROY THE TRANSMISSION IDENTIFICATION TAG.

## 18-Speed Transmission (On/Off Highway):

Model	No Spds.	Gear Ratios:											Relative Speed PTO Gear To Input R.P.M.		1 Length In. (mm)	2 Weight Lbs. (Kgs.)	3 Oil Cap. Pints (Liters)
		LO	1st	2nd	3rd	4th	5th	6th	7th	8th	Reverse	Right	Bottom				
RTLO-9118	18	DIR	14.71	10.20	7.34	5.26	3.78	2.70	1.94	1.39	1.00	3.89/14.71	.696	.696	950.6 (37.43)	1040 (471.9)	88 (41.6)
RTLO-1118	18	OD	12.45	8.62	6.21	4.45	3.20	2.28	1.64	1.18	.85	3.29/12.45			962.3 (37.89)	1071 (485.9)	88 (41.6)

### CHART NOTES:

1. Lengths measured from face of converter housing to front bottoming surface of companion flange or yoke.
2. Weight - Listed weights are with torque converter and include standard controls. Weight of standard controls is approximately 10 lbs. (4.5 kg.). All weights are approximate.
3. Oil Capacities are approximate, depending on inclination of engine and transmission. Always fill transmission with proper grade and type of lubricant to level of filler opening. See LUBRICATION.

# Proper Lubrication. . . the Key to long transmission life

Proper lubrication procedures are the key to a good all-around maintenance program. If the oil is not doing its job, or if the oil level is ignored, all the maintenance procedures in the world are not going to keep the transmission running or assure long transmission life.

Eaton®Fuller®Transmissions are designed so that the internal parts operate in an oil bath circulated by the motion of the gears and shafts.

Thus, all parts are amply lubricated if these procedures are closely followed:

1. Maintain oil level. Inspect regularly.
2. Change oil and filters regularly.
  - Use the correct grade and type of oil.
  - Buy oil from a reputable dealer.

Additives and friction modifiers are not recommended for use in Eaton Fuller Transmissions.

## Operating Temperatures

An external oil cooler is required on the converter enhanced transmission in order to maintain proper operating temperatures. Transmission oil temperature is sensed from the torque converter outlet port before the oil enters the cooler.

Normal operating temperature, when sensed from the torque converter outlet port, should be below 250°F; however, intermittent operating temperatures to 300°F do not harm the transmission. A dash light will signal high oil temperatures, 250°F or higher.

On vehicles equipped with two transmission oil temperature gauges, one gauge (required) senses torque converter oil as mentioned above, while the other gauge (optional) reads oil temperature from the transmission sump. The sump temperature represents oil that has circulated through the cooler. This temperature is normally below 225°F; however, intermittent sump temperatures to 250°F do not harm the transmission.

When the average temperature of the transmission oil exceeds the temperature limits as stated above, more frequent oil changes may be needed.

The following conditions in any combination can cause the recommended transmission oil temperatures to be exceeded: (1) operating the transmission in a “stall” condition while in the converter ratios; i.e., extended operation while in gear with the vehicle stopped or slowly moving, (2) high density of starts and stops at slow operating speed, (3) minimal cooler capacity and/or restricted air flow to the transmission oil cooler, (4) exhaust system too close to the transmission, (5) improper oil level/incorrect oil.

## Proper Lubrication Levels as Related to Transmission Operating Angles

If the transmission operating angle is more than 12°, improper lubrication can occur. A special kit may be required for sustained operation on grades greater than 12°.

Lubrication Change and Inspection	
<b>HIGHWAY USE</b>	
First 1,000 to 1,500 miles	Flush hydraulic system and change transmission oil filter on new units.
Every 2,500 miles	Inspect lubrication level. Check for leaks.
Every 50,000 miles or 1 year	Change transmission lubricant and filter.
<b>OFF-HIGHWAY USE</b>	
First 30 hours	Flush hydraulic system and change transmission oil filter on new units.
Every 40 hours	Inspect lubrication level. Check for leaks.
Every 500 hours	Change transmission lubricant and filter where severe dirt conditions exist.
Every 1,000 hours	Change transmission lubricant and filter. (Normal off-highway use.)

Recommended Lubricant		
Type	Grade (SAE)	Fahrenheit Ambient Temperature
Dexron II		Above 0°F

## Oil Dipstick



**WARNING**

Before working on a vehicle, place the transmission in neutral, set the parking brakes, and block the wheels.

## Maintaining Oil Level

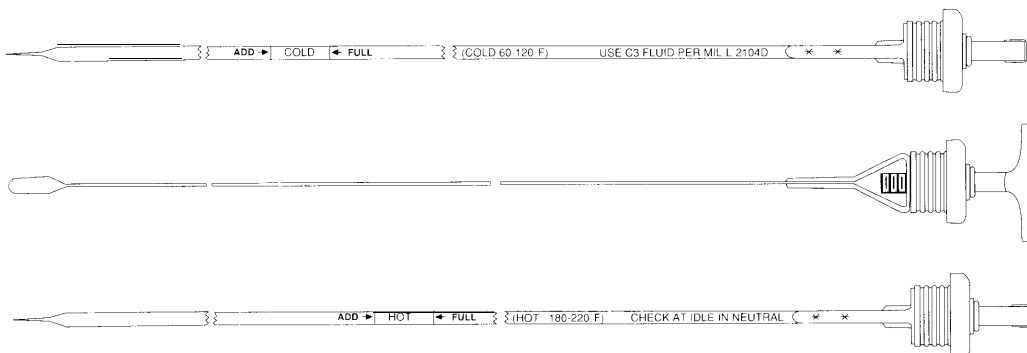

## Different Views of the Oil Dipstick

Make sure oil is within dipstick marks for the corresponding oil temperature. Oil should be checked at idle speed in the neutral position using the corresponding temperature band. Cold checks can be performed when the oil temperature is 60–120°F. The oil level should be within the dipstick “cold” band. Additional checks can be made with the transmission at operating temperature by using the “hot” band on the opposite side of the dipstick. The “hot” band temperature range is 180–220°F.

# OPERATION

## 18-Speed Transmission Shift Lever Patterns and Shifting Controls

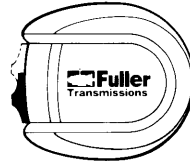
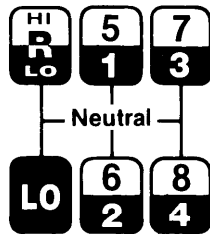

SHIFT LO-1-2-3-4 IN  
LO RANGE.

RANGE SHIFT . . .  
AND SHIFT 5-6-7-8 IN  
HI RANGE.

### OVERDRIVE

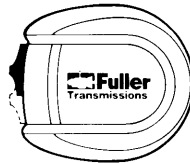
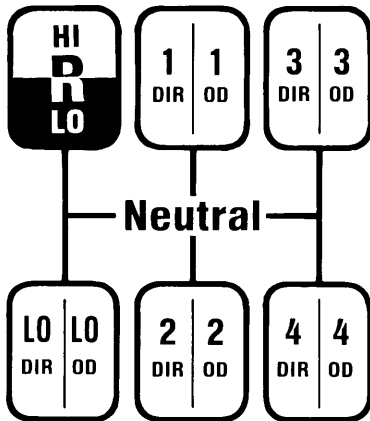

WHILE IN LO AND HI RANGE . . .  
Ratios can be split by  
moving the splitter  
Control Button to the  
forward position.

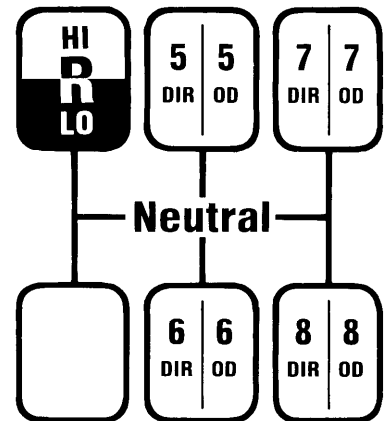

### ROAD RANGER VALVE (A-5013)

#### SPLITTER CONTROL BUTTON

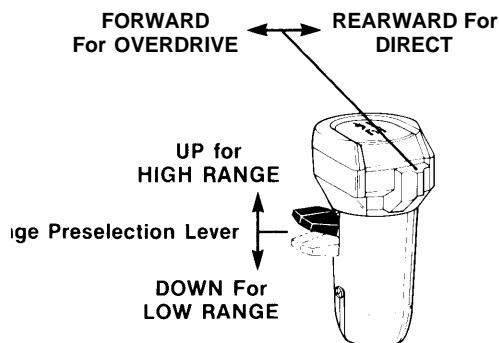



# POWER FLOW

The transmission must efficiently transfer the engines power. In terms of torque, to the vehicle's rear wheels. Knowledge of what takes place in the transmission during torque transfer is essential if troubleshooting or repair becomes necessary.

## Parts Identification

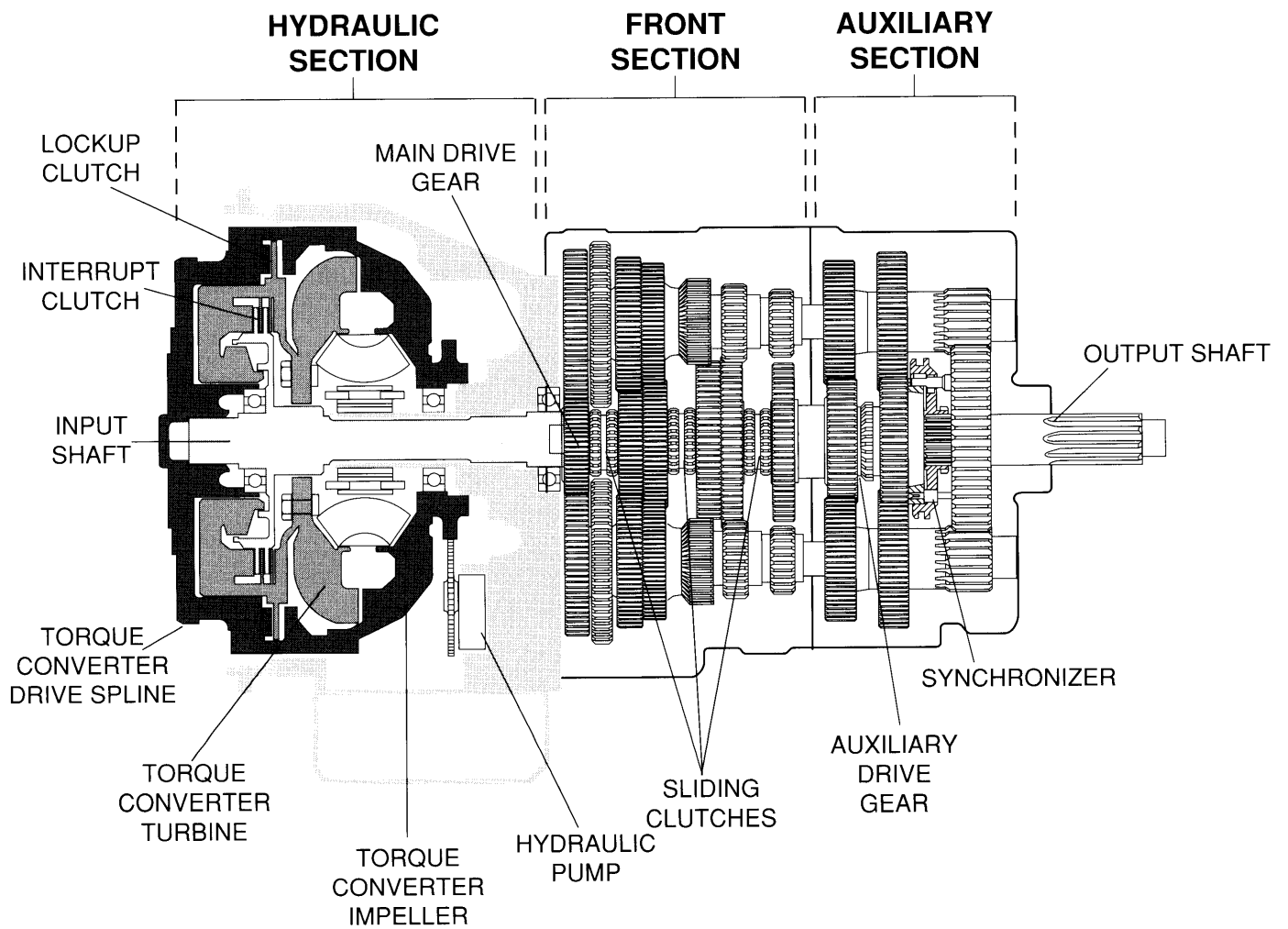

# POWER FLOW

---

## Torque Converter Mode

### Power Flow: LO Range (see figure A)

1. Power (torque) from the vehicle's engine is transferred to the torque converter's drive spline.
2. The impeller spins directing oil to the torque converter turbine.
3. The oil flow hits the turbine causing the turbine to rotate. The power is related to the speed difference between the impeller and the turbine.
4. The turbine is connected to the interrupt clutch housing. The interrupt clutch inner hub is splined directly to the transmission input shaft.
5. When the interrupt clutch is activated the housing and the inner hub are connected to complete the mechanical link and transfers power to the input shaft.
6. Input shaft splines engage the internal splines in the main drive gear hub.
7. Torque is split between the two countershaft drive gears.
8. Torque is delivered along both countershaft to mating countershaft gear of the "engaged" mainshaft gear (1st gear in this example.)
9. The internal clutching teeth in the engaged mainshaft gear hub, transfers torque to the mainshaft through the sliding clutch.
10. The mainshaft transfers torque directly to the auxiliary drive gear.
  1. The auxiliary drive gear splits torque between the two auxiliary countershaft drive gears.
  2. Torque is delivered along both countershaft to the "(engaged" LO range gear on the range mainshaft or output shaft.
  3. Torque is transferred to the output shaft through a sliding clutch.
  4. Torque is delivered to the driveline as LO RANGE 1st.

### Lockup Mode (see figure B)

1. Power (torque) from the vehicle's engine is transferred to the torque converter's drive spline.
2. The drive spline is connected to the lockup clutch.
3. The lockup clutch is splined directly to the interrupt clutch outer hub. When the lockup clutch is activated, the interrupt clutch is driven directly from the engine.
4. The interrupt clutch inner hub is splined directly to the transmission input shaft.
5. When the interrupt clutch is activated, the torque is transmitted directly from the engine to the input shaft from the lockup clutch. The losses from the slippage in the torque converter are eliminated in this manner.

### Auxiliary Section Power Flow: HI Range (see figure C)

6. Input shaft splines engage the internal splines in the main drive gear hub.
7. Torque is split between the two countershaft drive gears.
8. Torque is delivered along both countershaft to mating countershaft gear of the "engaged" mainshaft gear.
9. The internal clutching teeth in the engaged mainshaft gear hub transfers torque to the mainshaft through the sliding clutch.
10. The mainshaft transfers torque directly to the auxiliary drive gear.
11. The auxiliary drive gear transfers torque directly to the range mainshaft or output shaft through the "engaged" sliding clutch.
12. Torque is delivered through the output shaft to the driveline as HI RANGE 5th.

# POWER FLOW

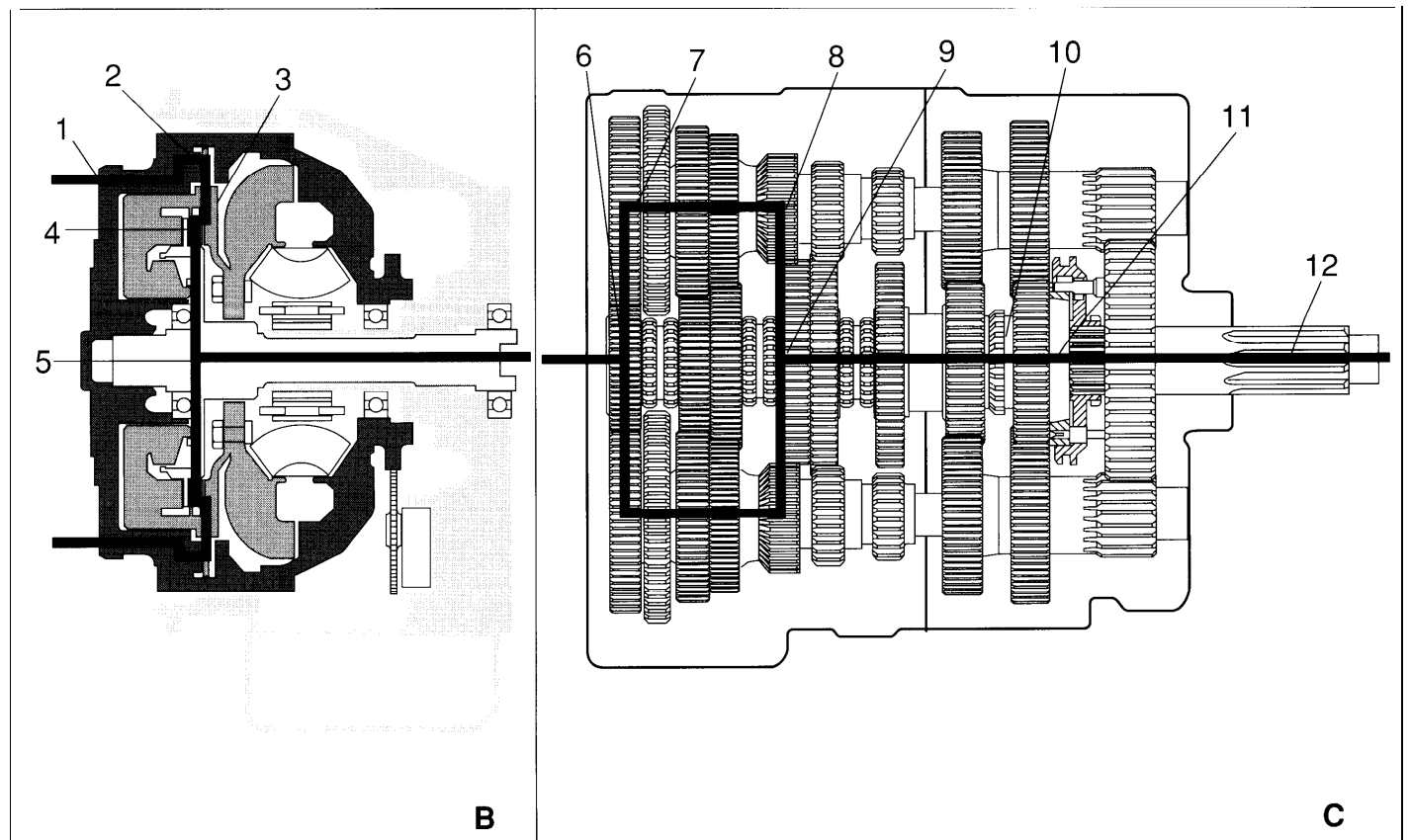
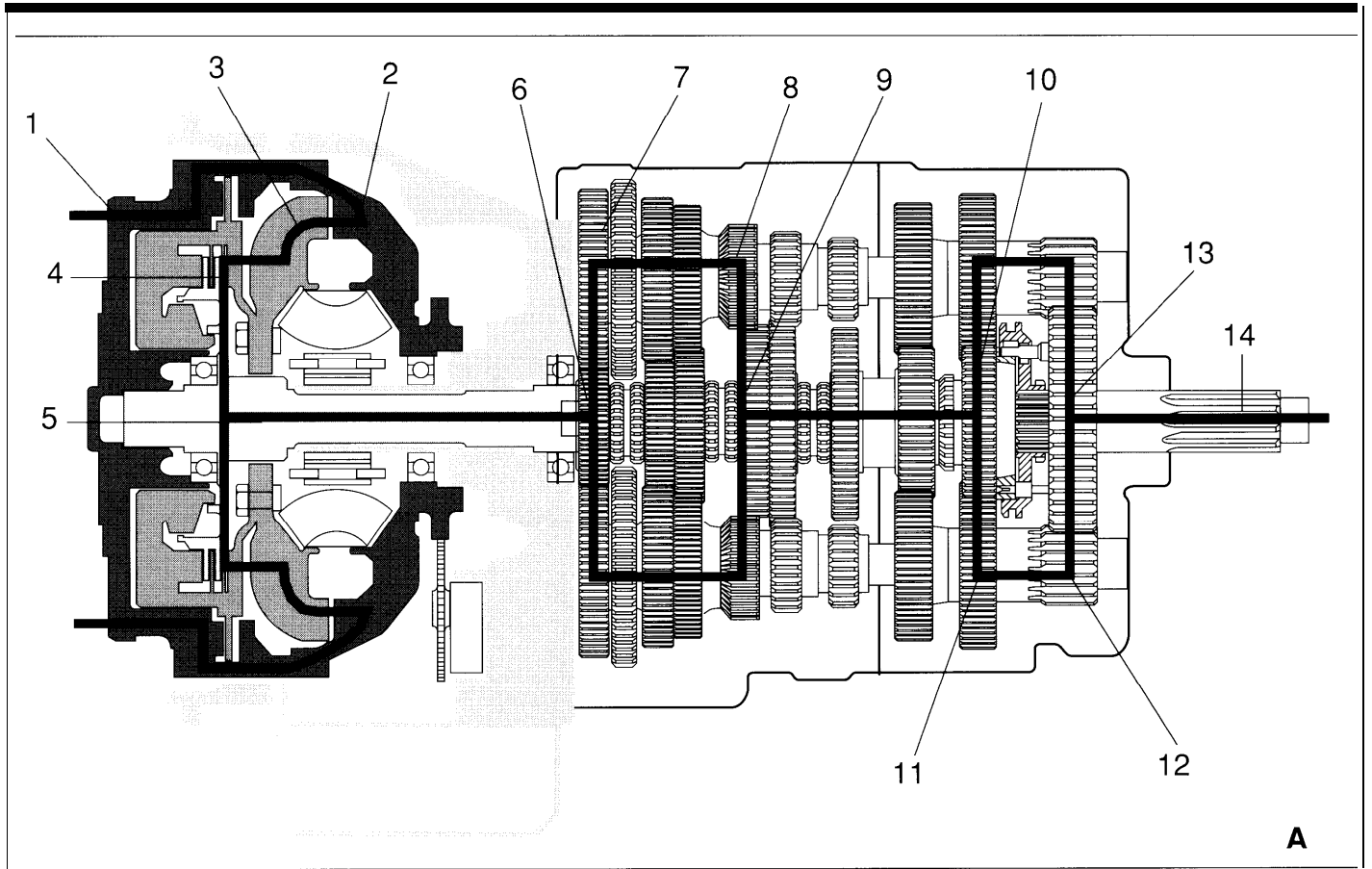

# POWER FLOW

The transmission must efficiently transfer the engine's power, in terms of torque, to the vehicle's rear wheels. Knowledge of what takes place in the transmission during torque transfer is essential when troubleshooting and making repairs.

## Front Section Power Flow (LO Range Direct)

1. Power (torque) from the vehicle's engine is transferred to the transmission's torque converter.
2. Splines of input shaft engage internal splines in hub of main drive gear.
3. Torque is split between the two countershaft drive gears.
4. Torque is delivered along both countershaft to mating countershaft gears of "engaged" mainshaft gear. The following cross section views illustrate a 1st/5th speed gear engagement.
5. Internal clutching teeth in hub of engaged mainshaft gear transfers torque to mainshaft through sliding clutch.
6. Mainshaft transfers torque directly to rear auxiliary drive gear.
7. The rear auxiliary drive gear splits torque between the two auxiliary countershaft drive gears.
8. Torque is delivered along both auxiliary countershaft to the "engaged" reduction gear on output shaft.
9. Torque is transferred to output shaft through sliding clutch.
10. Output shaft delivers torque to driveline.

### LO RANGE DIRECT

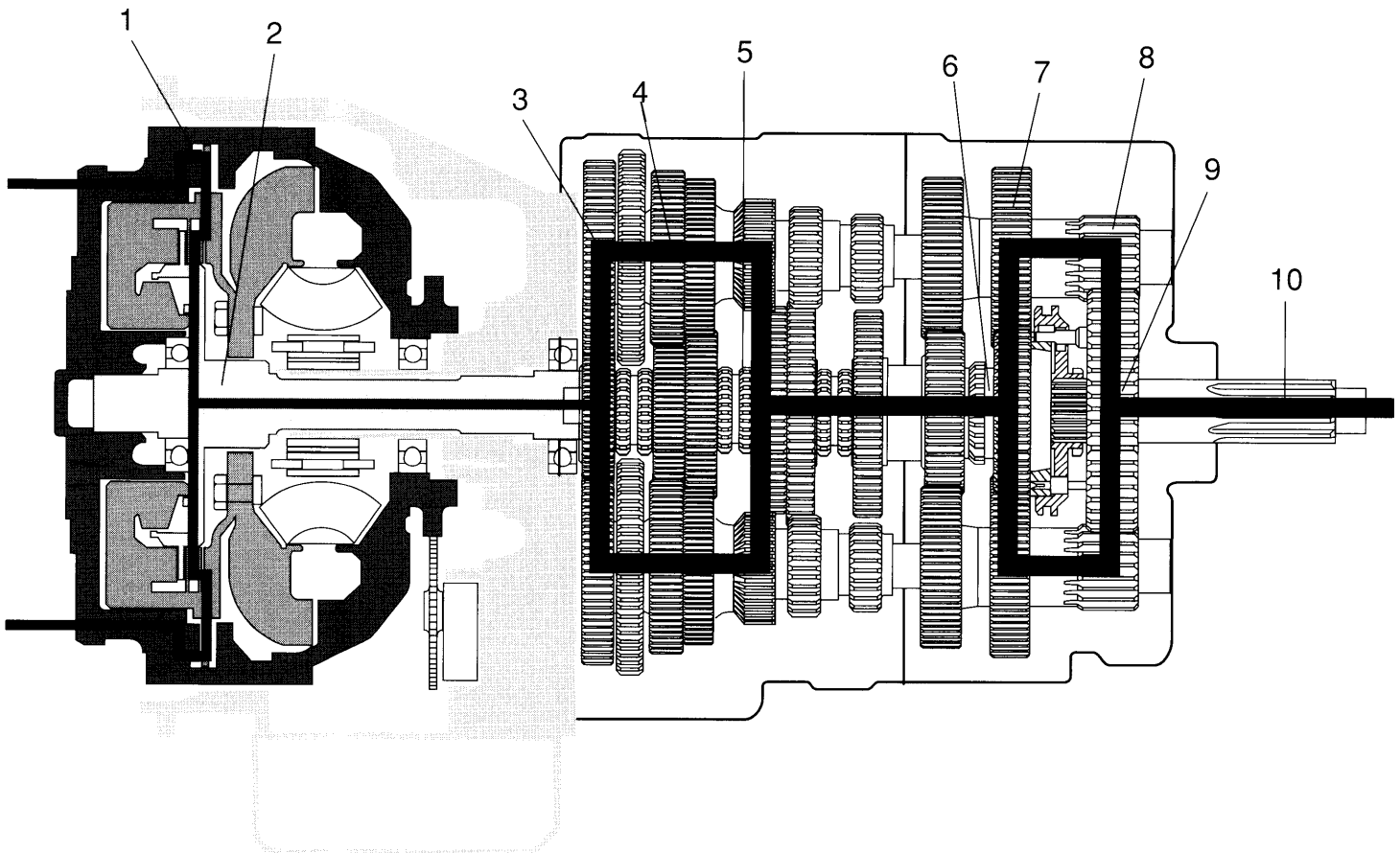

# POWER FLOW

## Auxiliary Section Power Flow: LO RANGE OVERDRIVE

7. The front auxiliary drive gear splits torque between the 9. Torque is transferred to the output shaft through sliding clutch.
8. Torque is delivered along both countershaft to 10. Torque is delivered to driveline as LO RANGE 1st gear OVERDRIVE.

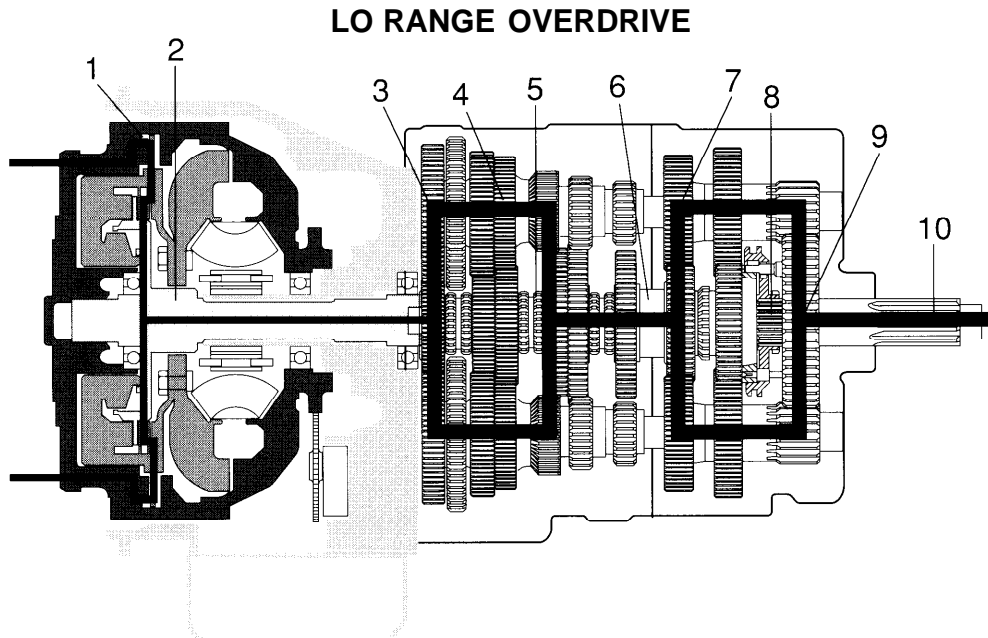

## Auxiliary Section Power Flow: HI RANGE DIRECT

7. The rear auxiliary drive gear transfers torque directly to the output shaft through '(engaged" sliding clutch.
8. Torque is delivered through the output shaft to driveline as HI RANGE 5th gear.

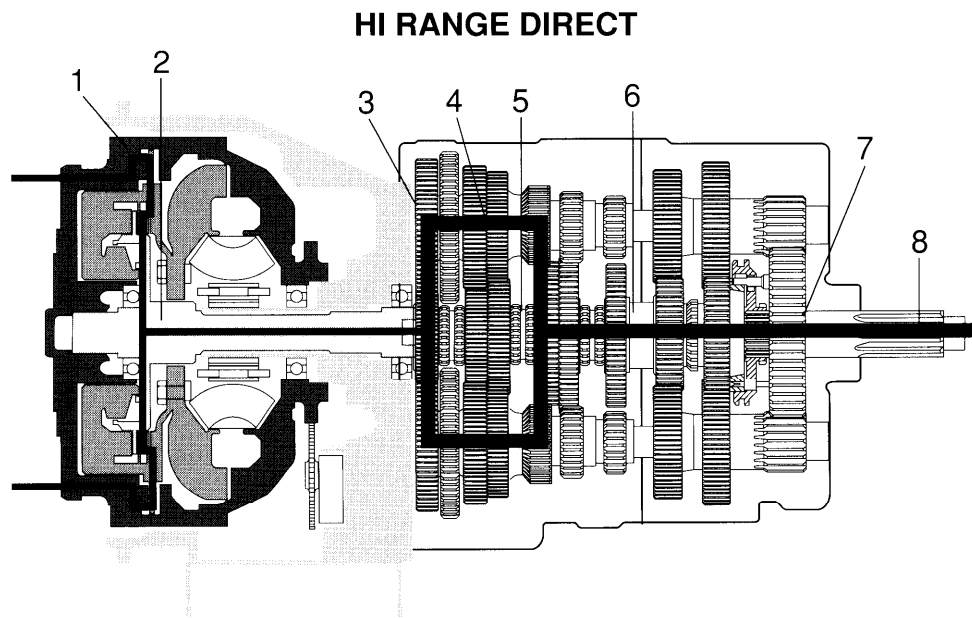

# POWER FLOW

## Auxiliary Section Power Flow: HI RANGE OVERDRIVE

7. The front auxiliary drive gear splits torque between the two auxiliary countershaft drive gears.
8. Torque is delivered along both auxiliary countershaft to mating countershaft gears of "engaged" rear auxiliary drive gear.
9. Torque is transferred to output shaft through the sliding clutch.
10. Output shaft delivers torque to driveline as HI Range 5th gear OVERDRIVE.

### HI RANGE OVERDRIVE

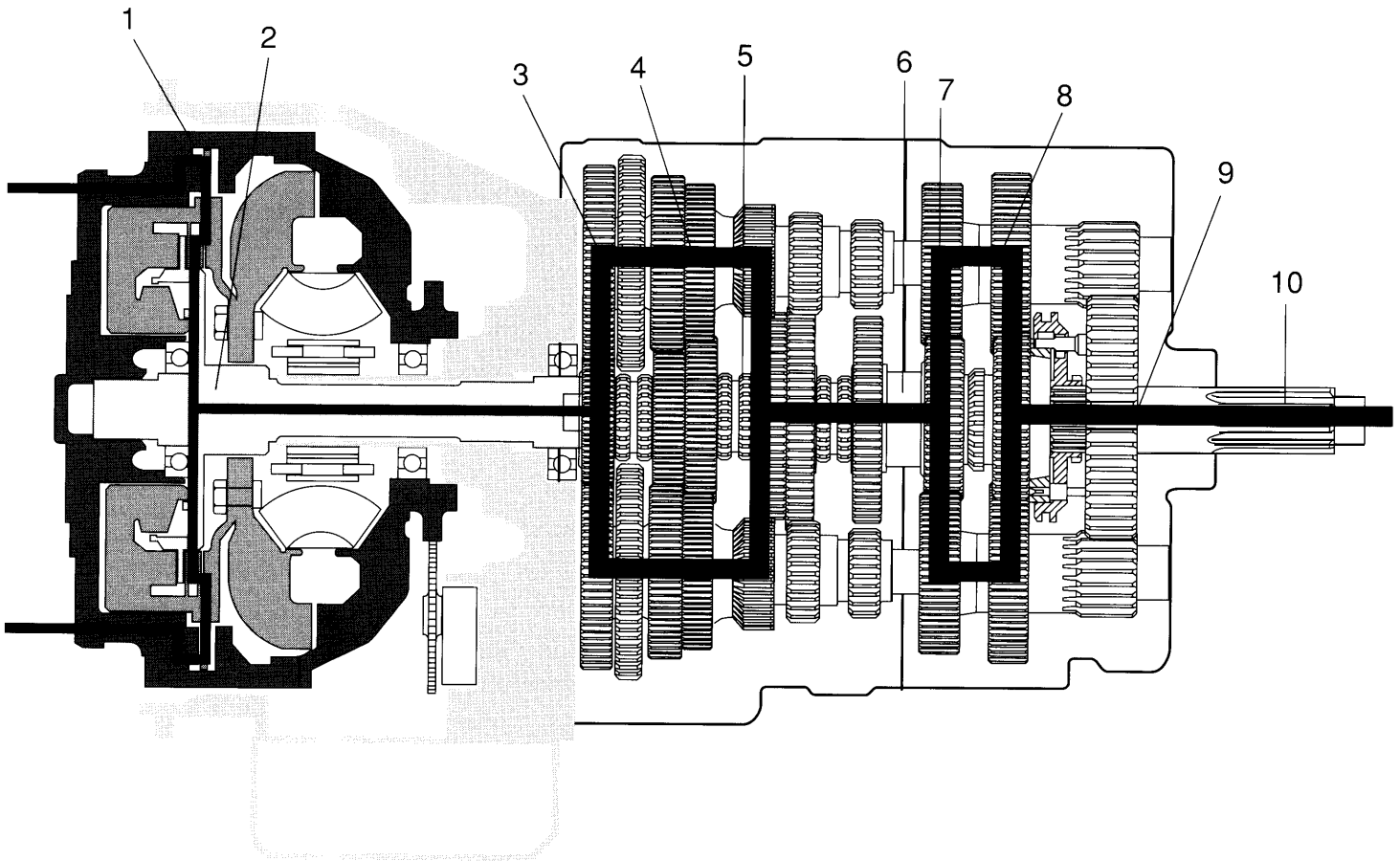

# TIMING

## Timing Procedures: All Models

It is essential that both countershaft assemblies of the front and auxiliary sections are "timed." This assures proper tooth contact is made between mainshaft gears seeking to center on the mainshaft during torque transfer and mating countershaft gears that distribute the load evenly. If not properly timed, serious damage to the transmission is likely to result from unequal tooth contact causing the mainshaft gears to climb out of equilibrium.

Timing is a simple procedure of marking the appropriate teeth of a gear set prior to installation and placing them in proper mesh while in the transmission. In the front section, it is necessary to time only the drive gear set. And depending on the model, only the LO range, deep reduction, or splitter gear set is timed in the auxiliary section.

### Front Section

#### A. Marking countershaft drive gear teeth.

1. Prior to placing each countershaft assembly into case, clearly mark the tooth located directly over the keyway of drive gear as shown. This tooth is stamped with an "O" to aid identification.

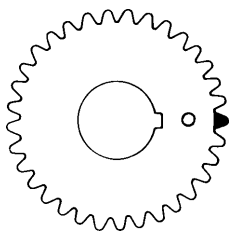

*Tooth on Countershaft directly over Keyway marked for timing*

Cut 7300 H11/86

#### B. Marking main drive gear teeth.

1. Mark *any* two adjacent teeth on the main drive gear.
2. Mark the two adjacent teeth located directly opposite the first set marked on the main drive gear. As shown below, there should be an equal number of unmarked gear teeth on each side between the marked sets.

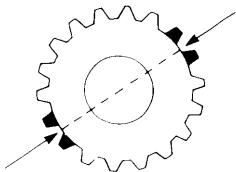

*Main drive gear teeth correctly marked for timing.*

Cut 7300G.11/86

- C. Meshing marked countershaft drive gear teeth with marked main drive gear teeth.  
(After placing the mainshaft assembly into case, the countershaft bearings are installed to complete installation of the countershaft assemblies.)
  1. When installing the bearings on left countershaft, mesh the marked tooth of countershaft drive gear with either set or two marked teeth on the main drive gear.
  2. Repeat the procedure when installing the bearings on right countershaft, making use of the remaining set of two marked teeth on the main drive gear to time assembly.

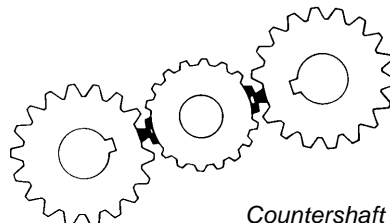

*Countershaft gear teeth meshed with drive gear teeth for correct timing.*

Cut 7300 F-1 1/86

### Auxiliary Section

- A. Timing the auxiliary countershaft and LO range gear.
  1. Mark *any* two adjacent teeth on the LO range gear of set to be timed. Then mark the two adjacent teeth located directly opposite the first set marked as shown in Illustration B.
  2. Prior to placing each auxiliary countershaft assembly into housing, mark the tooth stamped with an "O" on gear to mate with timed mainshaft gear as shown in Illustration A.
  3. Install the LO range gear on the out put shaft and into the auxiliary case.
  4. Seat the auxiliary countershaft bearings.
  5. Install the rear bearing cover and tighten to recommended torque.
  6. Place the auxiliary countershaft assemblies into position and mesh the marked teeth of the mating countershaft gears with the marked teeth of the LO range gear as shown in illustration C.

# TORQUE RECOMMENDATIONS

Correct torque application is extremely important to assure long transmission life and dependable performance. Over-tightening or under-tightening can result in a loose installation and, in many instances, eventually cause damage to transmission gears, shafts, and/or bearings. Use a torque wrench whenever possible to attain recommended lbs./ft. ratings. Do not torque capscrews dry.

## FRONT SECTION: ALL MODELS

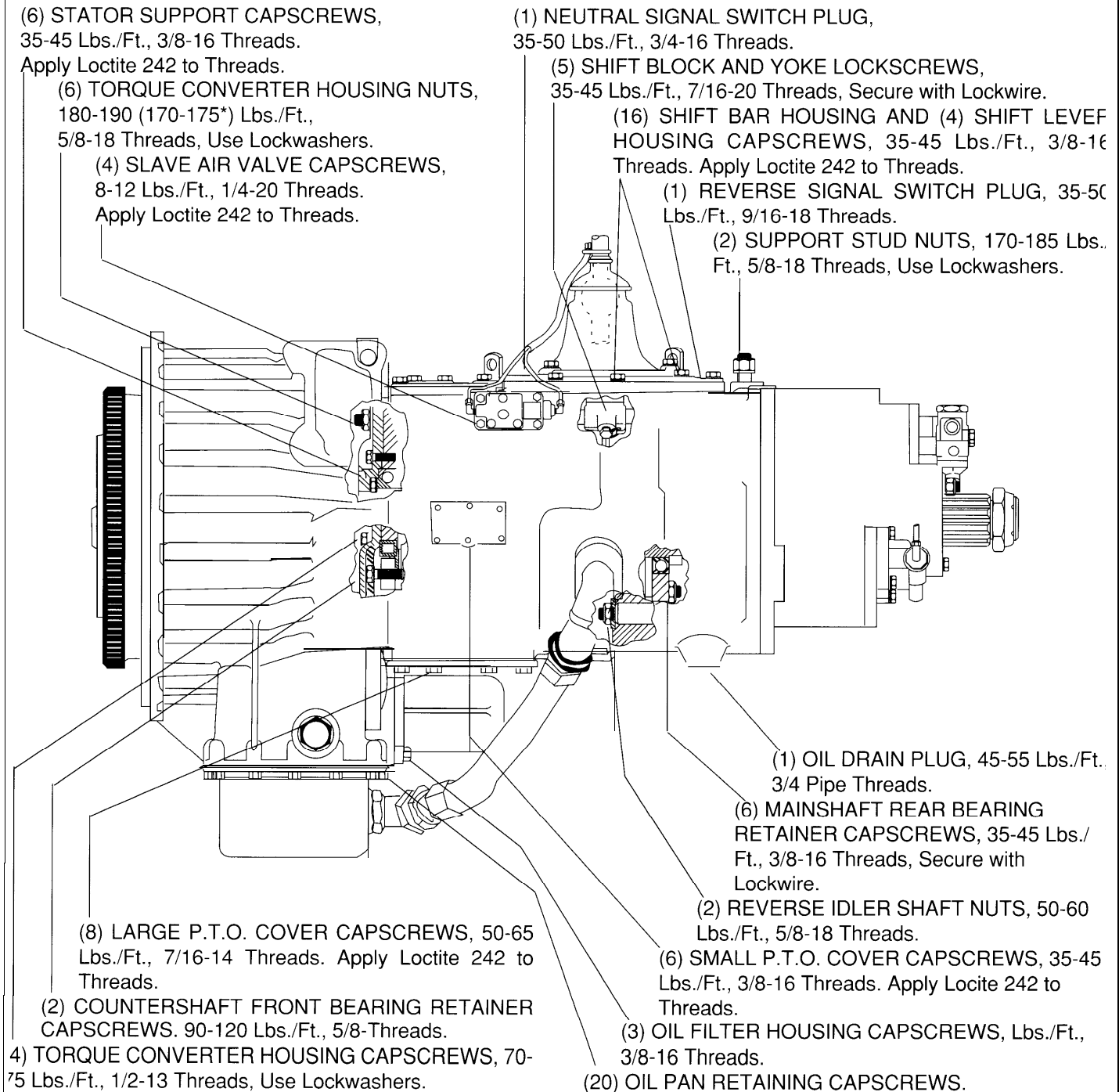



# TORQUE RECOMMENDATIONS

## AUXILIARY SECTIONS

2) AIR FILTER/REGULATOR MOUNTING  
CAPSCREWS 8-12 Lbs./Ft., 1/4-20 Threads.  
Apply Loctite 242 to Threads.

(1) RANGE CYLINDER SHIFT BAR NUT,  
70-85 Lbs./Ft., 5/8-18 Threads.

2) RANGE SHIFT YOKE CAPSCREWS,  
40-65 Lbs./Ft., 1/2-20 Threads,  
Secure with Lockwire.

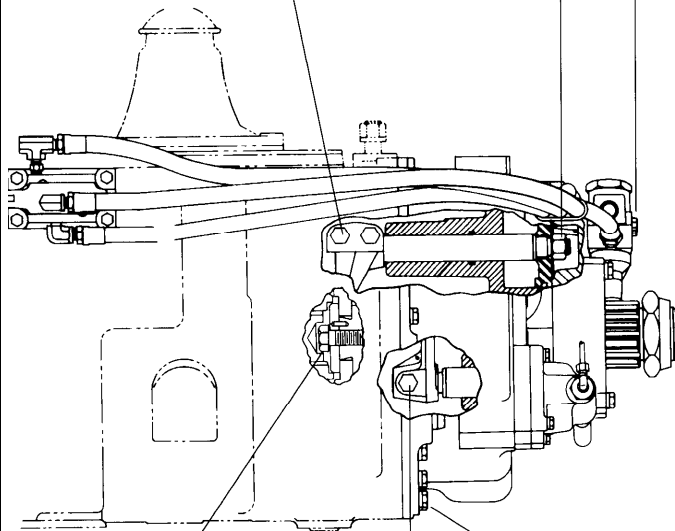

1) CAPSCREW REAR  
AUXILIARY RETAINING  
NUT, 90-120 Lbs./Ft.,  
5/8-18 Threads.

1) SPLITTER SHIFT YOKE LOCKSCREW,  
35-45 Lbs./Ft., 7/16-20 Threads,  
Secure with Lockwire.

(19) AUXILIARY HOUSING CAPSCREWS,  
35-45 Lbs./Ft., 3/8-16 Threads.  
Apply Loctite 242 to Threads.

(1) OUTPUT SHAFT NUT,  
450-500 Lbs./Ft.,  
2-16 Threads Oiled at  
Vehicle Installation.

(6) MAINSHAFT REAR BEARING COVER  
CAPSCREWS, 35-45 Lbs./Ft., 3/8-16 Threads.  
Apply Loctite 242 to Threads.

(4) RANGE CYLINDER MOUNTING CAPSCREWS,  
35-45 Lbs./Ft., 3/8-16 Threads,  
Apply Loctite 242 to Threads.

(4) RANGE CYLINDER COVER CAPSCREWS,  
35-45 Lbs./Ft., 3/8-16 Threads.  
Apply Loctite 242 to Threads.

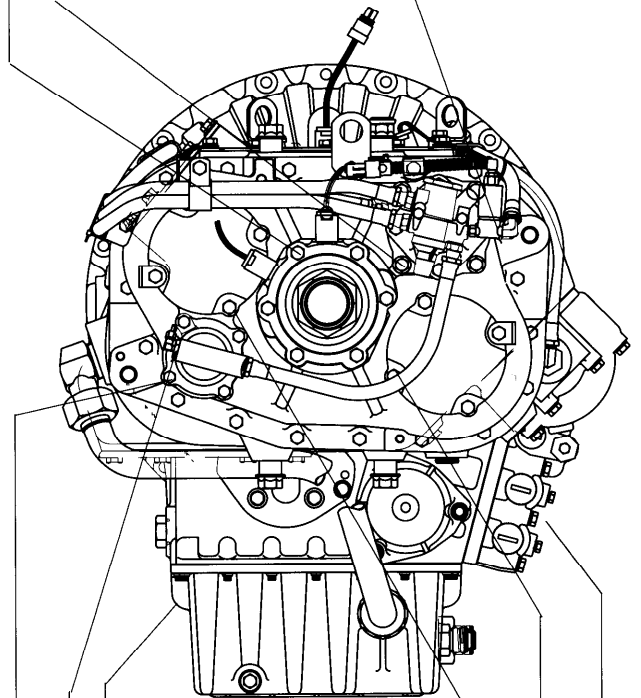

OIL PAN RETAINING  
CAPSCREWS  
14/20 Lbs./Ft., 5/16-18 Threads.

(1) RETAINING NUT/PLUG,  
40-50 Lbs./Ft., 5/8-18 Threads.

(4) SPLITTER CYLINDER COVER  
CAPSCREWS, 20-25 Lbs./Ft.,  
5/16-18 Threads.  
Apply Loctite 242 to Threads.

(8) COUNTERSHAFT REAR BEARING  
COVER CAPSCREWS, 35-45 Lbs./Ft.,  
3/8-16 Threads.  
Apply Loctite 242 to Threads.

(1) SPEEDOMETER HOUSING PLUG,  
35-50 Lbs./Ft., 13/16-20 Threads.  
Apply Loctite 242 to Threads.

HYDRAULIC VALVE CAPSCREWS  
26-32 Lbs./Ft., 3/8-16 Threads.

# TOOL REFERENCE

---

Some repair procedures pictured in this manual show the use of specialized tools. Their actual use is recommended as they make transmission repair easier, faster, and prevent costly damage to critical parts.

But for the most part, ordinary mechanic's tools such as socket wrenches, screwdrivers, etc., and other standard shop items such as a press, mauls and soft bars are all that is needed to successfully disassemble and reassemble any Fuller Transmission.

The specialized tools listed below can be obtained from a tool supplier or made from dimensions as required by the individual user. Detailed Fuller Transmission Tool Prints are available upon request by writing.

Eaton Corporation  
Transmission Dept.  
Technical Service Dept.  
P.O. Box 4013  
Kalamazoo, Michigan 49003

<b>PAGE</b>	<b>TOOL</b>	<b>HOW OBTAINED</b>
<b>45</b>	<b>Countershaft Retaining Strap</b>	<b>Made from Fuller Transmission Print T-64553</b>
<b>45</b>	<b>Auxiliary Section Hanger Bracket</b>	<b>Made from Fuller Transmission Print T-22823</b>
<b>55</b>	<b>Jaw Puller and Bearing Separator</b>	<b>Tool Supplier</b>
<b>72</b>	<b>Snap Ring Pliers</b>	<b>Tool Supplier</b>
<b>75</b>	<b>Impact Puller (1/2-13 Threaded End)</b>	<b>Tool Supplier</b>
<b>91</b>	<b>Countershaft Support Tool</b>	<b>Made from Fuller Transmission Print T-22247</b>
<b>109</b>	<b>Torque Wrench, 1000 Lbs./Ft. Capacity</b>	<b>Tool Supplier</b>

# Lubrication Change Procedure

## Draining Oil

Drain transmission while oil is warm. To drain oil, remove the two (2) drain plugs at the case bottom and oil pan. Clean the drain plugs and flush cooler circuit before re-installing.

## Refilling

The operational level should always be within the appropriate temperature bands on the dipstick. The exact amount of oil depends on the transmission inclination and model. Insufficient oil damages the pump and other components, and can affect the function and reduce the life of the transmission.

**DO NOT OVERFILL!** This causes overheating and loss of fuel economy.

When adding oil, types and brands of oil should not be mixed because of possible incompatibility.

Use clean oil and clean containers when filling transmission. Containers that have been used for anti-freeze or water should not be used for transmission oil.

1. Remove the dipstick and slowly add seven (7) gallons of the prescribed oil through the fill tube.
2. Place the transmission in neutral position and apply the parking brakes. Start the engine and let it idle for five (5) minutes, (this allows oil to fill the converter, main case, and cooling system), add oil as needed to obtain a level at the proper temperature range. Total oil quantity needed at this time should be approximately 10 gallons; this varies depending on the cooling system.
3. Increase the engine idle slowly to 1500 RPM for five (5) minutes. Now recheck the oil level at normal idle speed in neutral, again adding oil to obtain a level at the proper temperature range.
4. Replace the dipstick and tighten securely,

# Hydraulic System Flush Procedure

A complete hydraulic circuit flush should be completed when:

- first 1,000 to 1,500 miles for highway use or  
30 hours for off-highway use
- a catastrophic failure has occurred.

Assumption: The transmission is at ambient (65°F+/-20) temperature.

1. Begin draining the transmission from the two drain locations;
    - 1 ) At the transmission main case drain plug (rear@ bottom).
    - 2) At the converter housing oil pan drain plug.
  2. Disconnect the transmission cooler supply line between the transmission outlet and the oil cooler (not between the cooler and the transmission oil pan).
  3. With 80 PSI clean, dry air from a hose and nozzle, use a rubber stopper or clean rag to seal the air hose to the converter outlet hose.
  4. Apply air to the converter outlet for approximately two minutes to backflush oil into the transmission oil pan.
  5. Disconnect oil lines and dipstick tube from the sump pan.
  6. Remove and clean the sump pan.
  7. Remove the oil strainer/tube from the torque converter housing.
  8. Remove the oil strainer from the tube and clean.
  9. Assemble the oil strainer on the tube.
  10. Position a new gasket and install the oil strainer/tube.
- ⚠ CAUTION** Use the proper tool to tighten the retaining capscrews on the sump pan, damage can occur.
11. Install the sump pan. Tighten the retaining capscrews to 14 to 20 Lb.ft of torque.
  12. Connect oil lines and dipstick tube.
  13. Connect the hose between the transmission and cooler. Tighten to vehicle manufacturer's specifications.
  14. Install the transmission converter housing oil pan drain plug and tighten to 14 to 20 Lb.ft of torque.
  15. Install the transmission main case drain plug (rear @ bottom) and tighten to 45 to 50 Lb.ft of torque.
  16. Remove the transmission dipstick and slowly pour 7 gallons of Dexron® II fluid into the transmission.
  17. Apply the vehicle parking brakes and place the transmission lever in neutral. Start the engine and let it idle for five minutes. Check the dipstick periodically while the engine is idling, adding oil as needed, to obtain a level that is in the cold band on the dipstick. Total quantity added at this time should be approximately 10 gallons.
  18. With the transmission still in neutral, increase the engine idle speed to 1500 RPM and retain at this speed for five minutes. Now check the oil level at normal engine idle speed in neutral, again adding oil as required for a level 1 1/2" below the "add-hot" mark on the dipstick. Total oil quantity added at this time should be approximately 11 gallons.

## Transmission temperature (°F)

180 to 220—Oil level between the "add-hot" and "full-hot" marks.

Below 100—Oil level at the cold fill mark.

# How to Change Oil Sump Pan/Strainer Oil Filter

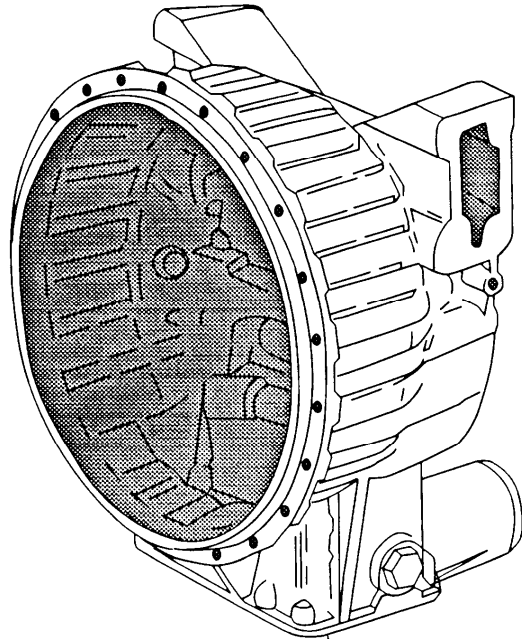

**NOTE:** To prevent oil leakage and loosening, use Fuller thread sealant/adhesive #71205 on all capscrews.

1. Install a new gasket.

2. Using the 2 screws, install the oil filter transfer tube. Tighten the screws to 14-20 Lb<sub>r</sub>.ft of torque.

3. Check the strainer for contaminants. If needed, wash the strainer in clean solvent.

5. Install the return hose/tube.

4. Position the oil sump pan. Install the retaining capscrews in oil sump pan. Tighten the capscrews to 14-20 Lb<sub>r</sub>.ft of torque.

## Transmission Oil Filter Change Procedure

Transmission oil must be drained before proceeding.

1. Remove the retaining capscrews.
2. Remove the filter housing.
3. Replace the oil filter and housing O-ring gasket.
4. Position the filter housing on the transmission.
5. Install the capscrews and tighten to 26 to 32 Lb.ft of torque.

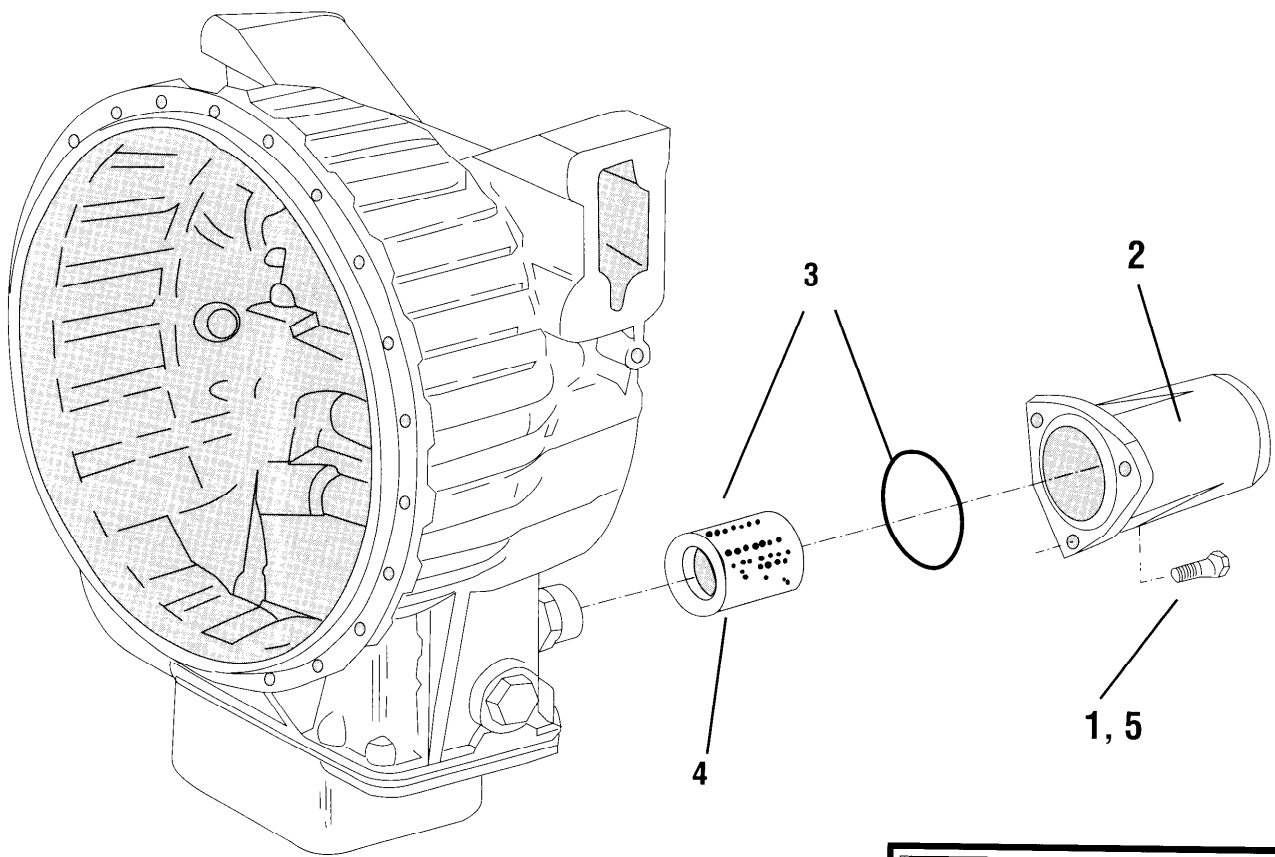

**NOTE:** To prevent oil leakage and loosening, use Fuller thread sealant/adhesive #71 205 on all capscrews.

**Note:** Item numbers refer to the illustration

## Preventive Maintenance Checks

### 1 — Lubricant and Filter

- Change at specified service intervals.
- Use only the types and grades recommended.
- Check lubrication lines and cooling circuit for leaks.
- Use only genuine Eaton® Fuller® filter elements, when servicing filter.

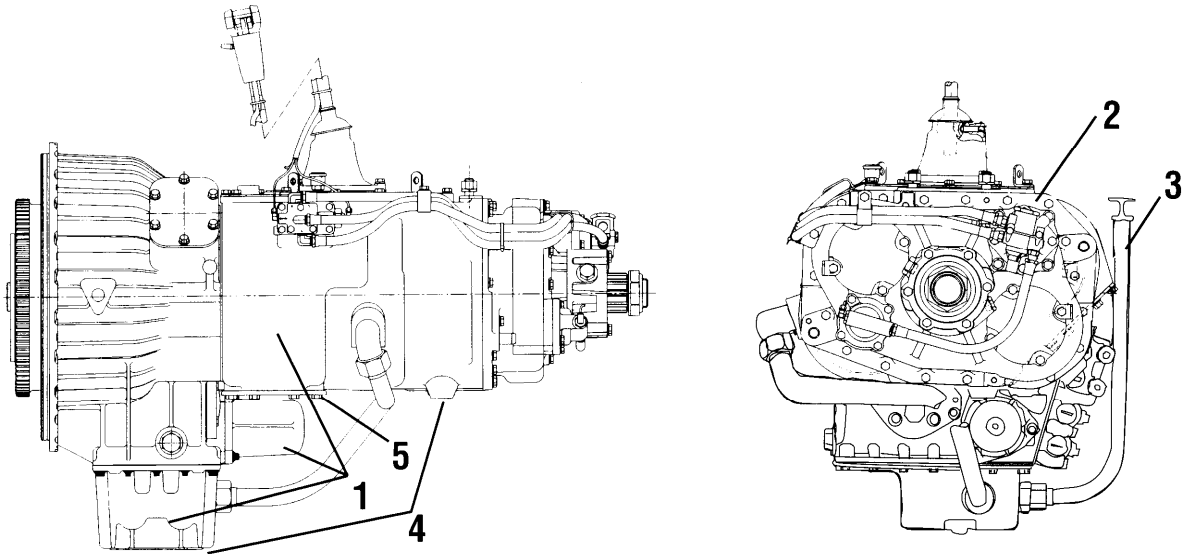

### 2 — Air System

- Annually replace the filter regulator element. If excessive contamination is present, service vehicle air/dryer system. The “MT” 18-Speed requires clean, dry air for proper operation. Check vehicle air dryer system regularly for proper operation.

### 3 — Dipstick

- Monitor oil level.
- Add oil if necessary.
- Tighten dipstick securely.

### 4 — Drain Plugs

- Tighten the drain plugs securely. Tighten the main case drain plug to 45-50 Lb<sub>f</sub>.ft of torque. Tighten oil pan plugs to 14-20 Lb<sub>f</sub>.ft of torque.

### 5 — Capscrews and Gaskets

- Check all capscrews, especially those on the PTO covers and rear bearing covers for looseness which can cause oil leakage. Tighten capscrews to 35-45 Lb<sub>f</sub>.ft of torque,
- Check PTO opening, oil sump pan/strainer, and rear bearing covers for oil leakage due to faulty gaskets.

# PRECAUTIONS

---

## Disassembly

It is assumed in the detailed disassembly instructions that the lubricant has been drained from transmission, the necessary linkage and air lines disconnected and the transmission has been removed from vehicle chassis. Removal of the gear shift lever housing assembly (or remote control assembly) is included in the detailed instructions (Disassembly and Reassembly—Shifting Controls); however, this assembly **MUST** be detached from shift bar housing before transmission can be removed.

FOLLOW CLOSELY EACH PROCEDURE IN THE DETAILED INSTRUCTIONS, MAKING USE OF THE TEXT, ILLUSTRATIONS AND PHOTOGRAPHS PROVIDED.

- 1. BEARINGS** - Carefully wash and relubricate all reusable bearings as removed and protectively wrap until ready for use. Remove bearings planned to be reused with pullers designed for this purpose.
- 2. ASSEMBLIES** - When disassembling the various assemblies, such as the mainshaft, countershaft, and shift bar housing, lay all parts on a clean bench in the same sequence as removed. This procedure will simplify reassembly and reduce the possibility of losing parts.
- 3. SNAP RINGS** - Remove snap rings with pliers designed for this purpose. Snap rings removed in this manner can be reused, if they are not sprung or loose.
- 4. INPUT SHAFT** - The input shaft can be removed from transmission without removing the countershafts, mainshaft, or main drive gear. Special procedures are required and provided in this manual.
- 5. CLEANLINESS** - Provide a clean place to work. It is important that no dirt or foreign material enters the unit during repairs. Dirt is an abrasive and can damage bearings. It is always good practice to clean the outside of the unit before starting the planned disassembly.
- 6. WHEN USING TOOLS TO MOVE PARTS** - Always apply force to shafts, housings, etc, with restraint. Movement of some parts is restricted. Never apply force to the part being driven after it stops solidly. The use of soft hammers, bars and mauls for all disassembly work is recommended.

## Inspection

Before reassembling the transmission, check each part carefully for abnormal or excessive wear and damage to determine reuse or replacement. When replacement is necessary, use only genuine Fuller Transmission parts to assure continued performance and extended life from your unit.

Since the cost of a new part is generally a small fraction of the total cost of downtime and labor, avoid reusing a questionable part which could lead to additional repairs and expense soon after initial reassembly. To aid in determining the reuse or replacement of any transmission part, consideration should also be given to the unit's history, mileage, application, etc.

Recommended inspection procedures are provided in the following checklist.

### A. BEARINGS

1. Wash all bearings in clean solvent. Check balls, rollers and raceways for pitting, discoloration, and spalled areas. Replace bearings that are pitted, discolored, or spalled.
2. Lubricate bearings that are not pitted, discolored, or spalled and check for axial and radial clearances.
3. Replace bearings with excessive clearances.
4. Check bearing fits. Bearing inner races should be tight to shaft; outer races slightly tight to slightly loose in case bore. If bearing spins freely in bore, however, case should be replaced.

### B. GEARS

1. Check gear teeth for frosting and pitting. Frosting of gear tooth faces present no threat of transmission failure. Often in continued operation of the unit, frosted gears will "heal" and not progress to the pitting stage. And in most cases, gears with light to moderate pitted teeth have considerable gear life remaining and can be reused. But gears with advanced stage pitting should be replaced.
2. Check for gears with clutching teeth abnormally worn, tapered, or reduced in length from clashing in shifting. Replace gears found in any of these conditions.



# PRECAUTIONS

---

## Inspection (cont'd.)

3. Check axial clearance of gears. Where excessive clearance is found, check gear snap ring, washer, spacer, and gear hub for excessive wear. Maintain .005" to .012" axial clearance between mainshaft gears.

## C. SPLINES

1. Check splines on all shafts for abnormal wear. If sliding clutch gears, companion flange, have worn into the sides of the splines, replace the specific shaft affected.

## D. TOLERANCE WASHERS

1. Check surfaces of all tolerance washers. Washers scored or reduced in thickness should be replaced.

## E. REVERSE IDLER GEAR ASSEMBLIES

1. Check for excessive wear from action of roller bearings.

## F. GRAY IRON PARTS

1. Check all gray iron parts for cracks and breaks. Replace or repair parts found to be damaged.

## G. SHIFT BAR HOUSING ASSEMBLY

1. Check for wear on shift yokes and blocks at pads and lever slot. Replace excessively worn parts.
2. Check yokes for correct alignment. Replace sprung yokes.
3. Check lock screws in yokes and blocks. Tighten and rewire those found loose.
4. If housing has been disassembled, check neutral notches of shift bars for wear from interlock balls.

## H. GEAR SHIFT LEVER HOUSING ASSEMBLY

1. Check spring tension on shift lever. Replace tension spring and washer if lever moves too freely.
2. If housing is disassembled, check spade pin and corresponding slot in lever for wear. Replace both parts if excessively worn.

## I. BEARING COVERS

1. Check covers for wear from thrust of adjacent bearing. Replace covers damaged from thrust of bearing outer race.
2. Check bores of covers for wear. Replace those worn oversize.

## J. SLIDING CLUTCHES

1. Check all shift yokes and yoke slots in sliding clutches for extreme wear or discoloration from heat.
2. Check engaging teeth of sliding clutches for partial engagement pattern.

## K. SYNCHRONIZER ASSEMBLY

1. Check synchronizer for burrs, uneven and excessive wear at contact surface, and metal particles.
2. Check blocker pins for excessive wear or looseness.
3. Check synchronizer contact surfaces on the auxiliary drive and low range gears for excessive wear.

## L. O-RINGS

1. Check all O-rings for cracks or distortion. Replace if worn.

# PRECAUTIONS

---

## Reassembly

Make sure that interiors of case and housings are clean. It is important that dirt and other foreign materials be kept out of the transmission during reassembly. Dirt is an abrasive and can damage polished surfaces of bearings and washers. Use certain precautions, as listed below, during reassembly.

1. **GASKETS** - Use new gaskets throughout the transmission as it is being rebuilt. Make sure all gaskets are installed. An omission of any gasket can result in oil leakage or misalignment of bearing covers.
2. **CAPSCREWS** - To prevent oil leakage, use Loctite 242 thread sealant on all capscrews. For torque ratings, see TORQUE RECOMMENDATIONS.
3. **O-RINGS** - Lubricate all O-rings with silicone lubricant.
4. **ASSEMBLY** - Refer to the illustrations provided in the detailed disassembly instructions as a guide to reassembly.
5. **INITIAL LUBRICATION** - Coat all limit washers and splines of shafts with Lubriplate during reassembly to prevent scoring and galling of such parts.
6. **AXIAL CLEARANCES** - Maintain original axial clearances of .005" to .012" for mainshaft gears.
7. **BEARINGS** - Use of flanged-end bearing drivers is recommended for the installation of bearings. These special drivers apply equal force to both bearing races, preventing damage to balls/rollers and races while maintaining correct bearing alignment with bore and shaft. Avoid using a tubular or sleeve-type driver, whenever possible, as force is applied to only one of the bearing races. See TOOL REFERENCE.
8. **UNIVERSAL JOINT COMPANION FLANGE OR YOKE** - Pull the companion flange or yoke tightly into place with the output shaft nut, using 450-500 foot-pounds of torque. Make sure the speedometer drive gear or a replacement spacer of the same width has been installed. Failure to pull the companion flange or yoke tightly into place will permit the output shaft to move axially with resultant damage to the rear bearing.

**IMPORTANT: REFER TO THE APPROPRIATE ILLUSTRATED PARTS LIST (SPECIFIED BY MODEL SERIES) TO ENSURE THAT PROPER PARTS ARE USED DURING REASSEMBLY OF THE TRANSMISSION.**

# CHANGING INPUT SHAFT

## Special Procedure

In some cases, it may become necessary to replace the input shaft due to excessive wear on the splines. Except for removal of the shift bar housing assembly, the input shaft can be removed without further disassembly of the transmission. Removal of the torque converter housing is required.

**NOTE:** The following illustration and instructions pertain to changing the input shaft ONLY. To change the main drive gear, complete disassembly of the front section is required.

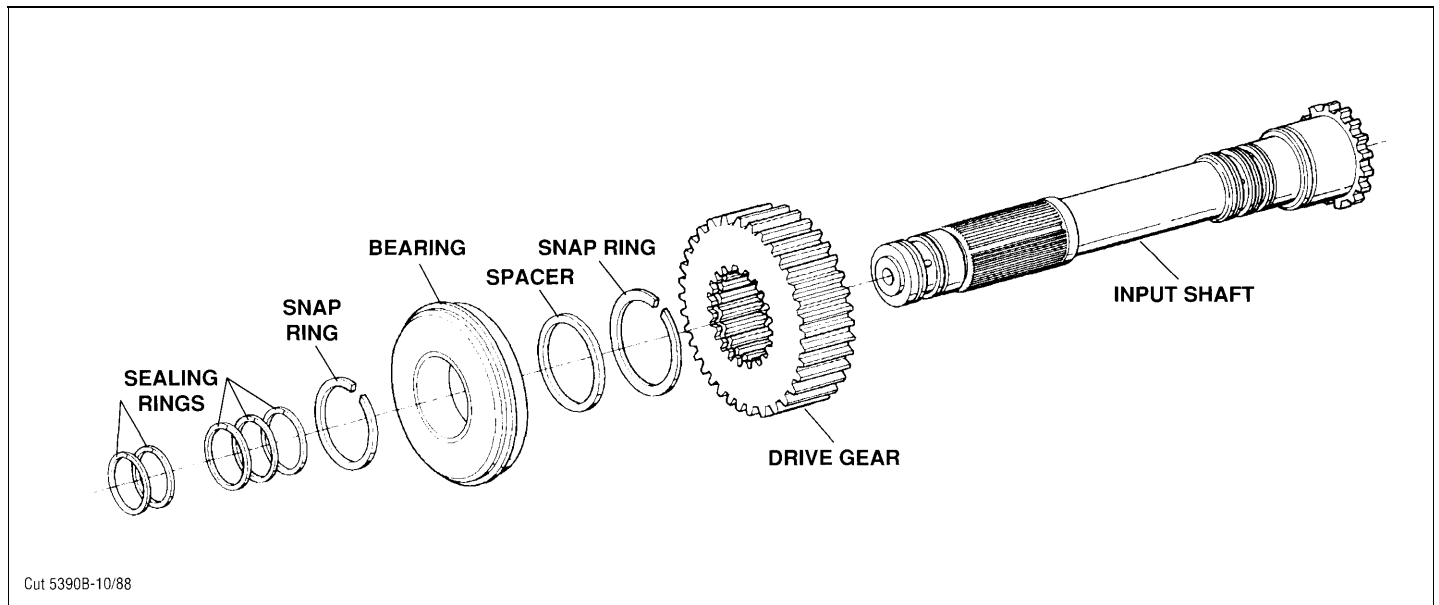

## Disassembly

1. Remove the gear shift lever housing assembly (or remote control assembly) from shift bar housing, and the shift bar housing assembly from transmission case.
2. Remove the bearing retaining snap ring from groove in shaft.
3. Push down on input shaft to cock bearing in bore. Drive input shaft toward rear of transmission, through bearing as far as possible. Pull input shaft forward to expose snap ring of bearing.
4. Use pry bars to complete removal of bearing.
5. Remove drive gear spacer and snap ring.
6. Pull input shaft forward and out of drive gear and case.

## Reassembly

1. If necessary, install bushing in pocket of input shaft.
2. Install new input shaft into splines of main drive gear, just far enough to expose snap ring groove in I.D. of drive gear.
3. Install snap ring in snap ring groove inside drive gear.
4. Install drive gear spacer on input shaft.
5. Install drive gear bearing on input shaft and into case bore.
6. Install bearing retainer snap ring.
7. To facilitate proper reinstallation of the shift bar housing assembly on case, make sure mainshaft sliding clutches are placed in the neutral position.
8. Reinstall the shift bar housing assembly, the front bearing cover and all other parts and assemblies previously removed, making sure to replace the gaskets used.

# AIR SYSTEM

---

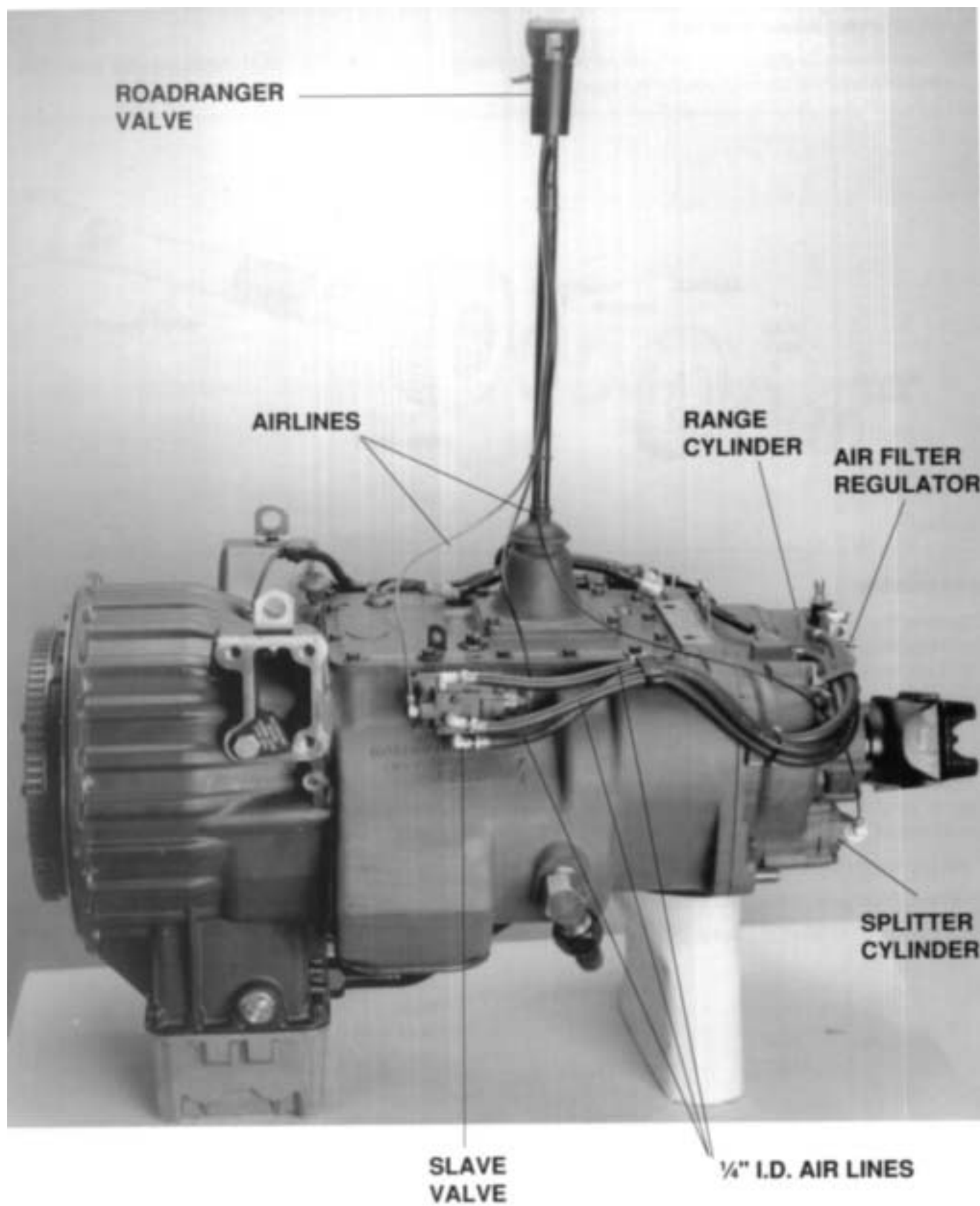

# AIR SYSTEM

## RANGE SHIFT AIR SYSTEM

### Operation

The Range Shift Air System consists of the air filter/regulator, slave valve, a Range Control Valve or Master Control Valve, range cylinder, fittings and connecting air lines. See Air System Schematics.

CONSTANT AIR from the air filter/regulator is supplied to the "S" or Supply Port of slave valve and passed through to the INLET or "S" Port of control valve.

WHILE IN LO RANGE, the control valve is OPEN and AIR is returned to slave valve at the "P" or End Port. This signals the valve to supply AIR in line between the LO Range or "L" Port of slave valve and the LO Range Port of range cylinder housing. AIR received at this port moves the range piston to the rear and causes the auxiliary LO RANGE gear to become engaged.

WHILE IN HI RANGE, the control valve is CLOSED and NO AIR is returned to the slave valve. This signals the slave valve to supply AIR in line between the HI Range or "H" Port of valve and the HI Range Port of range cylinder cover. AIR received at this port moves the range piston forward to engage the auxiliary drive gear with sliding clutch and bypass the LO RANGE gear set.

Range shifts can be made ONLY when the gear shift lever is in, or passing through, neutral. Thus, the range desired can be PRESELECTED while the shift lever is in a gear position. As the lever is moved through neutral, the actuating plunger in the shift bar housing releases the slave valve, allowing it to move to the selected range position.

### Trouble Shooting

If the transmission fails to make a range shift or shifts too slowly, the fault may be in the Range Shift Air System or actuating components of the shift bar housing assembly.

To locate the trouble, the following checks should be made with normal vehicle air pressure applied to the system, but with the engine off.

**⚠ WARNING** NEVER WORK UNDER A VEHICLE WHILE ENGINE IS RUNNING as personal injury may result from the sudden and unintended movement of vehicle under power. Always place transmission in the neutral position.

#### 1. INCORRECT AIR LINE HOOK-UPS (See Air System Schematics)

With the gear shift lever in neutral, move the control that provides range selection UP and DOWN.

- A. If the air lines are crossed between control valve and slave valve, there will be CONSTANT AIR flowing from the exhaust port of control valve WHILE IN HI RANGE.

- B. If the air lines are crossed between the slave valve and range cylinder, the transmission gearing will not correspond with the range selection. A LO RANGE selection will result in a HI RANGE engagement and vice versa.

#### 2. AIR LEAKS

With the gear shift lever in neutral, coat all air lines and fittings with soapy water and check for leaks, moving the control that provides range selection UP and DOWN.

- A. If there is a steady leak from the exhaust port of control valve, O-rings and/or related parts of the control valve are defective.
- B. If there is a steady leak from breather of slave valve: an O-ring in valve is defective, or there is a leak past O-rings of range cylinder piston.
- C. If transmission fails to shift into LO RANGE or is slow to make the range shift and the case is pressurized, see Check No. 7 of this section.
- D. Tighten all loose connections and replace defective O-rings and parts.

#### 3. AIR FILTER/REGULATOR (See illustration, Page 26.)

With the gear shift lever in neutral, check the breather of air filter/regulator assembly. There should be NO AIR leaking from this port. The complete assembly should be replaced if a steady leak is found.

Cut off the vehicle air supply to the air filter/regulator assembly, disconnect the air line at fitting in Supply OUTLET and install an air gage in opened port. Bring the vehicle air pressure to normal. Regulated air pressure should be 57.5 to 62.5 Psi.

**DO NOT ADJUST SCREW AT BOTTOM OF REGULATOR TO OBTAIN CORRECT READINGS.** The air regulator has been PREADJUSTED within the correct operating limits. Any deviation from these limits, especially with regulators that have been in operation for some time, is likely to be caused by dirt or worn parts. If replacement or cleaning of the filter element does nothing to correct the air pressure readings, replace the complete assembly, as the air regulator is nonserviceable.

#### 4. RANGE VALVE (See Page 27.)

With the gear shift lever in neutral, select HI RANGE and disconnect the air line at the OUTLET or "P" Port of control valve.

# AIR SYSTEM

A. When LO RANGE is selected, a steady blast of air will flow from opened port. Select HI RANGE to shut off air flow. This indicates the control valve is operating properly. Reconnect air line.

B. If control valve does not operate properly, check for restrictions and air leaks. Leaks indicate defective or worn O-rings.

## 5. HI RANGE OPERATION

With the gear shift lever in neutral, select LO RANGE and disconnect the 1/4" I.D. air line at the port of range cylinder cover. Make sure this line leads from the HI Range or "H" Port of slave valve.

A. When HI RANGE is selected, a steady blast of air should flow from disconnected line. Select LO RANGE to shut off air flow.

B. Move the shift lever to a gear position and select HI RANGE. There should be NO AIR flowing from disconnected line. Return the gear shift lever to the neutral position. There should now be a steady flow of air from disconnected line. Select LO RANGE to shut off air flow and reconnect air line.

C. If the air system does not operate accordingly, the slave valve or actuating components of the shift bar housing assembly are defective.

### IMPORTANT: RANGE PRESELECTION

The plunger pin, located in case bore between the slave valve and actuating plunger of shift bar housing, prevents the slave valve from operating while the shift lever is in a gear position. When the lever is moved to or through the neutral position, the pin is released and the slave valve becomes operational.

## 6. LO RANGE OPERATION

With the gear shift lever in neutral, select HI RANGE and disconnect the 1/4" I.D. air line at the fitting on range cylinder housing. Make sure this line leads from the LO Range or "L" Port of slave valve.

A. When LO RANGE is selected, a steady blast of air should flow from disconnected line. Select HI RANGE to shut off air flow.

B. Move the shift lever to a gear position and select LO RANGE. There should be NO AIR flowing from disconnected line. Return the gear shift lever to the neutral position. There should now be a steady flow of air from disconnected line. Select HI RANGE to shut off air flow and reconnect air line.

C. If the air system does not operate accordingly, the slave valve or actuating components of the shift bar housing assembly are defective.

## 7. RANGE CYLINDER (Refer to the following illustration.)

If any of the seals in the range cylinder assembly are defective, the range shift will be affected.

A. Leak at either O-ring A results in complete failure to make a range shift; steady flow of air from breather of slave valve in both ranges.

B. Leak at gasket B results in a steady flow of air to atmosphere while in HI RANGE.

C. Leak at O-ring C results in a slow shift to LO RANGE; pressurizing of transmission case.

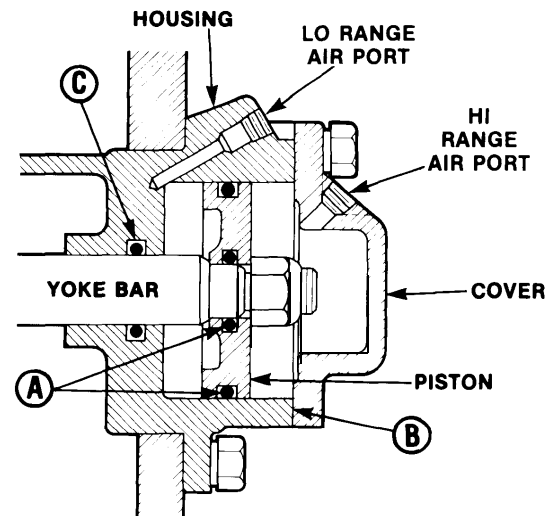

Cut 7420-5/87

Range Cylinder Assembly—All Models

# AIR SYSTEM

## AIR FILTER/REGULATOR ASSEMBLY

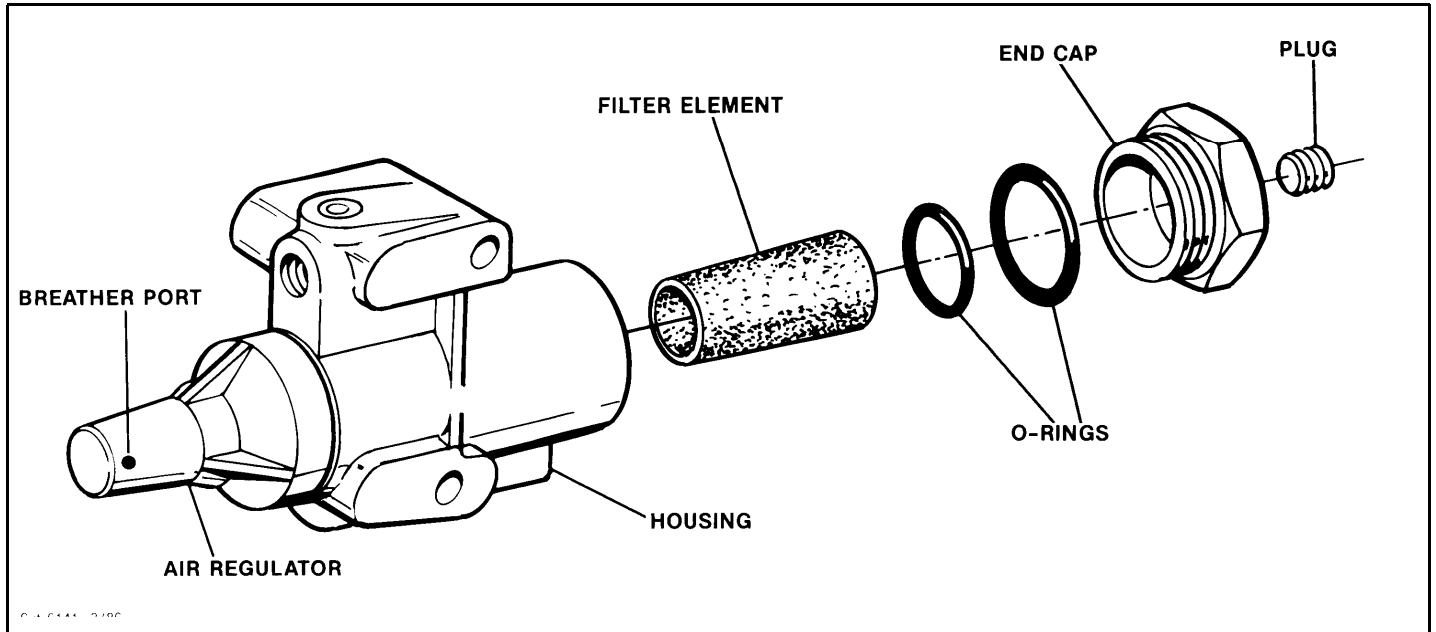

The air filter contains a replaceable filter element which can be removed by turning out the end cap. This element should be cleaned at each oil change, or more often under high humidity conditions. Replace if necessary.

## SLAVE VALVES

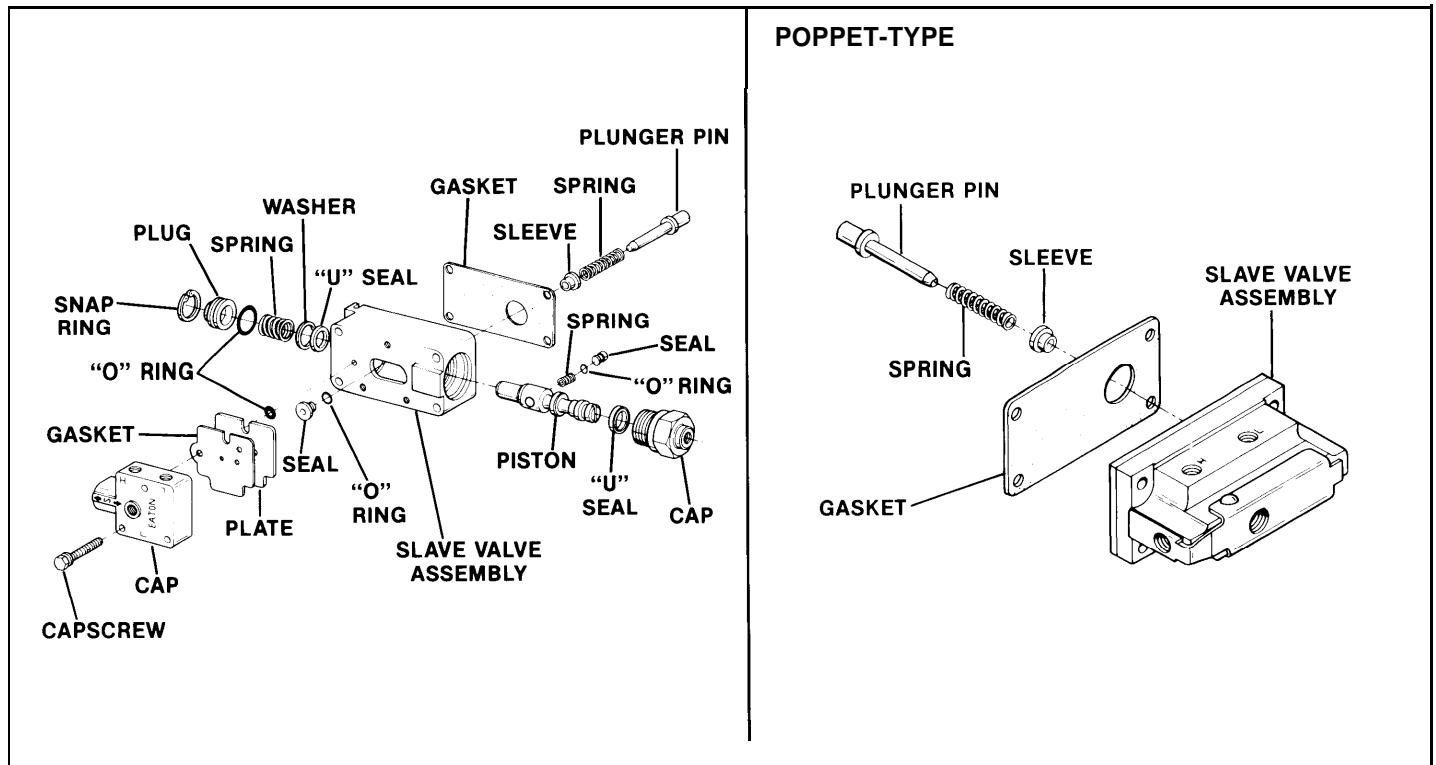

Refer to the drawing for disassembly and reassembly of the piston-type slave valve assemblies. **Should the poppet-type slave valve assembly prove to be defective, replace the complete assembly, as it is non-serviceable.** The actuating components used with these valve assemblies are non-interchangeable. Failure to use the correct plunger pin, spring, and alignment sleeve during installation on the transmission will cause hard shifting in LO Range gears.

# AIR SYSTEM

## ROADRANGER VALVE A-5013

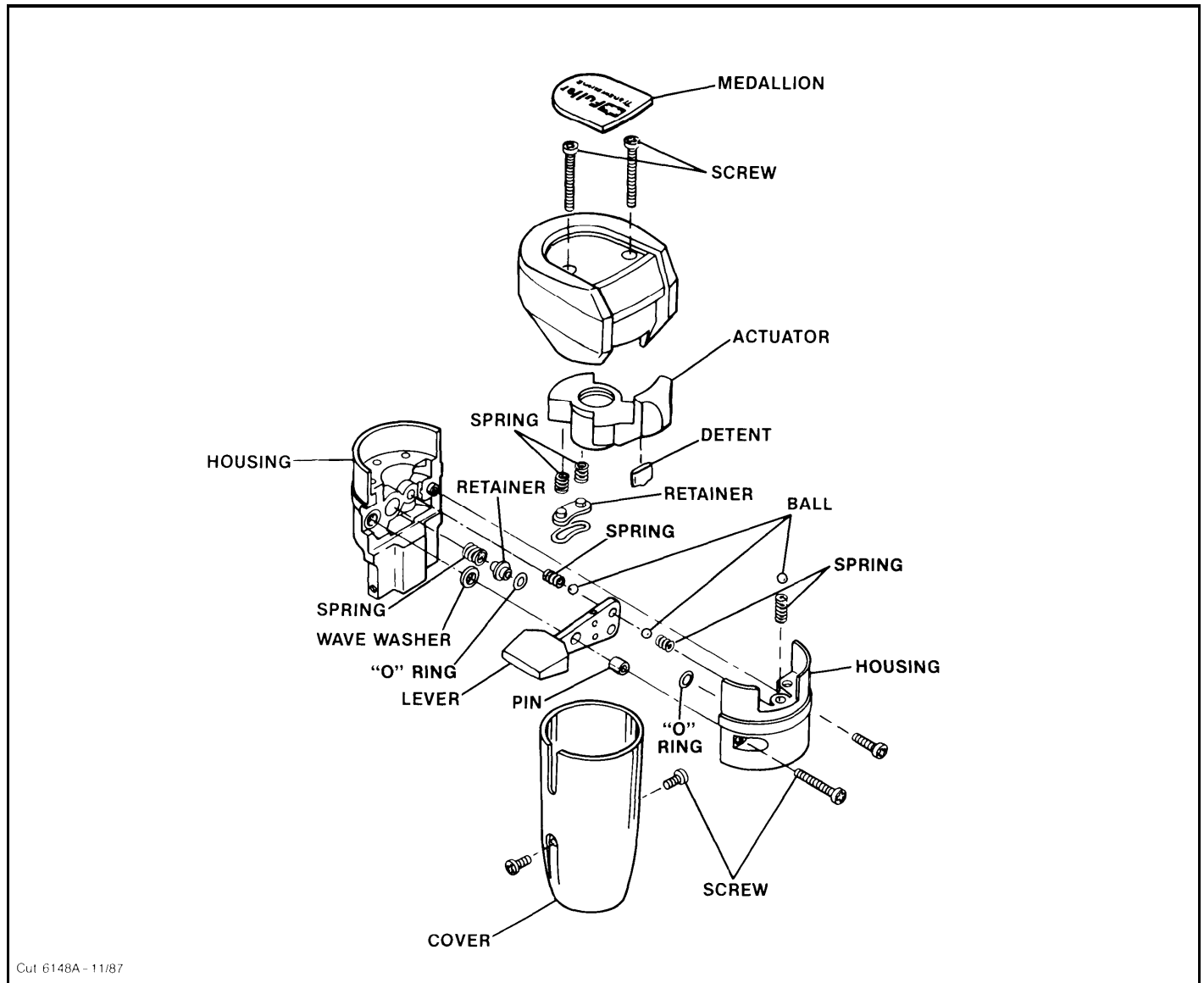

### Removal and Disassembly

1. Remove two screws holding bottom cover to valve and slide cover down gearshift lever to expose air line fittings. Disconnect air lines.
2. Loosen jam nut and turn control valve from gear shift lever.
3. Pry medallion from recess in top cover.
4. Turn out the two screws to remove the top cover from valve housing.
5. Turn out the two screws in side of valve housing to separate the housing.
6. Remove the Range Preelection Lever from left housing and the position balls and guide from lever.

7. If necessary, remove the spring and O-ring from bores in left housing.
8. If necessary, remove the springs, O-ring and sleeve from bores in right housing.

### Reassembly and Installation

1. Refer to the drawing for proper reassembly. Use a VERY SMALL amount of silicone lubricant on the O-rings to avoid clogging ports. A small amount of grease on the position springs and balls will help to hold them in place during reassembly
2. Install control valve on gear shift lever and tighten jam nut.
3. Attach air lines and install bottom cover.



# AIR SYSTEM

## SPLITTER SHIFT AIR SYSTEM:

### Operation

In addition to the various components of the Range Shift Air System, the Splitter Shift Air System utilizes a splitter cylinder and the Roadranger Valve A-5013. See Air System Schematics.

CONSTANT AIR from the air filter/regulator assembly is supplied to the splitter cylinder at the port on right side of cylinder cover. The Insert valve installed in cover (see Page 30) provides the proper air flow needed to move the splitter piston in the cylinder (rearward to engage rear auxiliary drive gear for operation in direct; forward to engage the front auxiliary drive gear for operation in overdrive).

WHILE IN HI OR LO RANGE, AIR needed to make the splitter selection and complete the shift is supplied to the Roadranger valve from the fitting at the "S" Port of slave valve. When the overdrive selection is made, the AIR passes through the Roadranger valve and is supplied to the Left Port of cylinder cover.

With Splitter Control Button in the "DIRECT"/REARWARD position, the "SP" Port of the Roadranger valve is CLOSED and NO AIR is supplied to the Left Port of the Splitter cylinder cover.

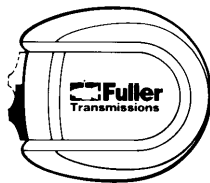

Button REARWARD  
("SP" Port CLOSED)

While in HI or LO Range the button can be moved FORWARD to operate in 'OVERDRIVE. The "SP" Port of valve is OPENED when overdrive is selected, supplying AIR to the Left Port of the Splitter cylinder cover.

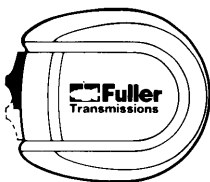

Button FORWARD  
("SP" Port OPENED)

### Trouble Shooting

If the transmission fails to shift or shifts too slowly to or from the "split" position, the fault may be in the Splitter Shift Air System or related components of the Range Shift Air System.

To locate the trouble, the following checks should be made with normal vehicle air pressure supplied to the system, but with the engine off.

**WARNING** NEVER WORK UNDER A VEHICLE WHILE ENGINE IS RUNNING as personal injury may result from the sudden and unintended movement of vehicle under power. Always place transmission in the neutral position

**NOTE:** It is assumed that correct PSI readings were obtained from the air filter/regulator and all air lines have been checked for leaks.

#### 1. Air Supply (See Air System Schematics.)

With the gear shift lever in neutral, select HI or LO RANGE and loosen the connection at the "S" Port of the Roadranger Valve until it can be determined that AIR is supplied to valve. Reconnect air line.

If there is NO AIR, check for a restriction in the air line between the Roadranger valve and slave valve. Make sure this line is connected to fitting at the supply Port of slave valve.

#### 2. Roadranger Valve (See Page 27 and Air System Schematics.)

With the gear shift lever in neutral, disconnect the air line at the Left Port of splitter cylinder cover, making sure this line leads from the "SP" Port of the Roadranger Valve.

- WHILE IN HI or LO RANGE, move the Splitter Control Button FORWARD. There should be AIR flowing from disconnected line. Move the button REARWARD to shut off air flow and reconnect air line.
- If the preceding conditions do not exist, the Roadranger valve is defective, or there is a restriction in the air lines.

#### 3. Splitter Cylinder. (Refer to the following illustration.)

If any of the seals in the splitter cylinder assembly are defective, the splitter shift will be affected. The degree of air lost will govern the degree of failure, from slow shifting to complete shift failure.

- Leak at O-ring A results in a slow shift to engage rear auxiliary drive gear pressurizing of transmission case; auxiliary gearing can be disengaged.

# AIR SYSTEM

- B. Leak at O-ring B results in slow shifting or complete failure to engage and disengage front or rear auxiliary drive gearing; steady flow of air from exhaust port of Roadranger valve and/or cylinder cover when Splitter Control Button is in the REARWARD position.
- C. Leak at gasket C results in a slow shift to disengage rear auxiliary drive gear; steady flow of air to atmosphere.

## 4. Insert Valve (See Page 30.)

Any constant flow of air from exhaust port of cylinder cover usually indicates a faulty insert valve. Exhaust should occur ONLY BRIEFLY when Splitter Control Button is moved REARWARD WHILE IN LO and HI RANGE.

A faulty insert valve, leaking at the O-rings of valve O.D. or from inner seals results in constant air leak and shift failure. Two indications of defective O-rings or seals are:

- A. CONSTANT AIR flowing from exhaust port of cylinder cover.
- B. CONSTANT AIR flowing from Exhaust Port "E" of control valve WHILE SPLITTER CONTROL BUTTON IS REARWARD OR FORWARD (providing the control valve is operating properly).

The three O-rings in position on valve O.D. can be replaced. However, if an inner seal is damaged, the complete assembly MUST be replaced.

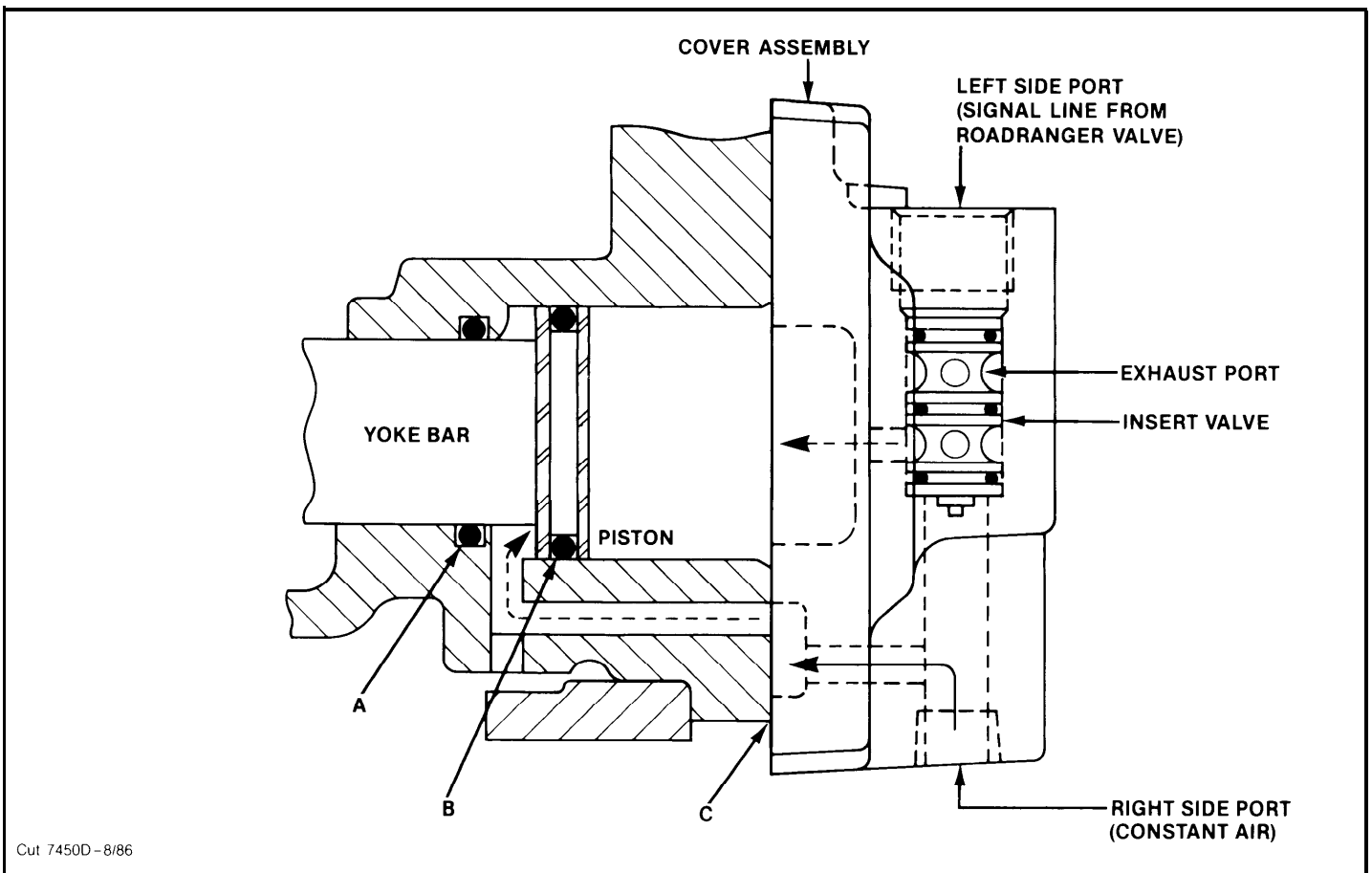

# AIR SYSTEM

## INSERT VALVE: (EQUIPPED WITH ROADRANGER VALVE A-5013)

The insert valve is a self-contained 1-3/16" valve assembly located in the splitter cylinder cover. It CAN-

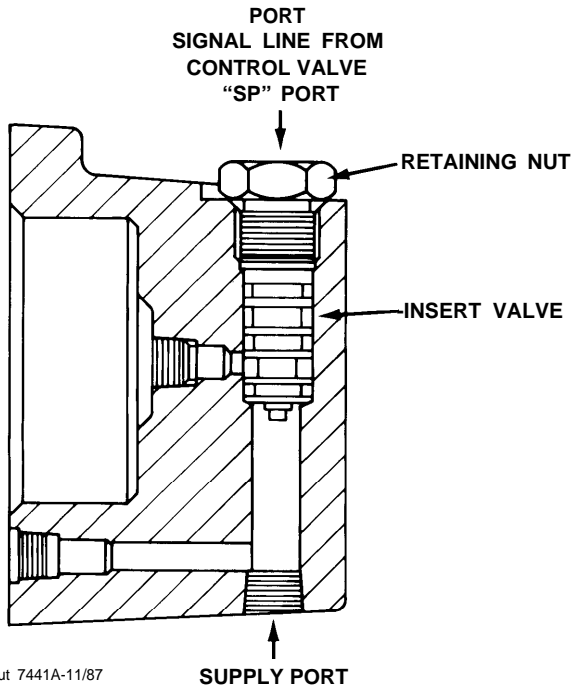

NOT be disassembled except for the three O-rings on outer diameter. The O-rings provide a stationary seal and do not move in cylinder.

When installing the insert valve in bottom edge of cover, apply Fuller #71206 silicone lubricant or its equivalent to O-rings and cylinder walls. Install valve in bore with flat surface to the outside. When installing the special valve retaining nut, apply Fuller #71204 adhesive/sealant or its equivalent to threads and tighten. See TORQUE RECOMMENDATIONS.

Travel of the small insert valve piston is only 3/16". As shown in the illustrations below, when NO AIR is applied to the top side of valve piston, CONSTANT AIR supplied from the regulator passes to the FRONTSIDE of cylinder piston, moving the yoke bar backward to engage the REAR AUXILIARY DRIVE GEAR (LO RANGE DIRECT AND HI RANGE DIRECT). The piston moves up to cut off air to the back side of the cylinder piston. This air is exhausted out the cylinder cover as the piston moves rearward.

When AIR is applied to top side of valve piston, through signal line, the piston moves down passing air through the bottom of insert valve to the front and backside of the cylinder piston, moving the yoke bar FORWARD engaging the FRONT AUXILIARY DRIVE GEAR (LO RANGE OVERDRIVE AND HI RANGE OVERDRIVE).

### LOW RANGE AND HIGH RANGE DIRECT

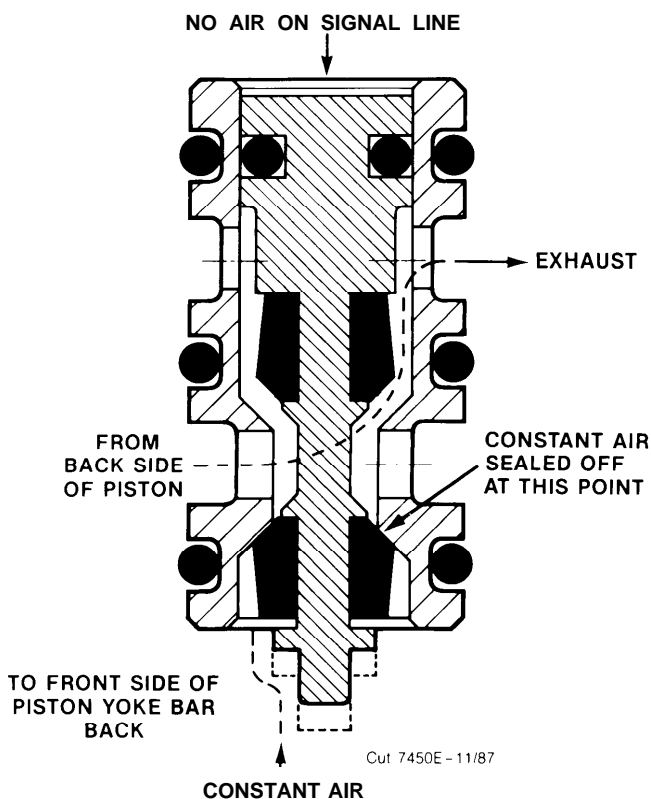

### OVERDRIVE

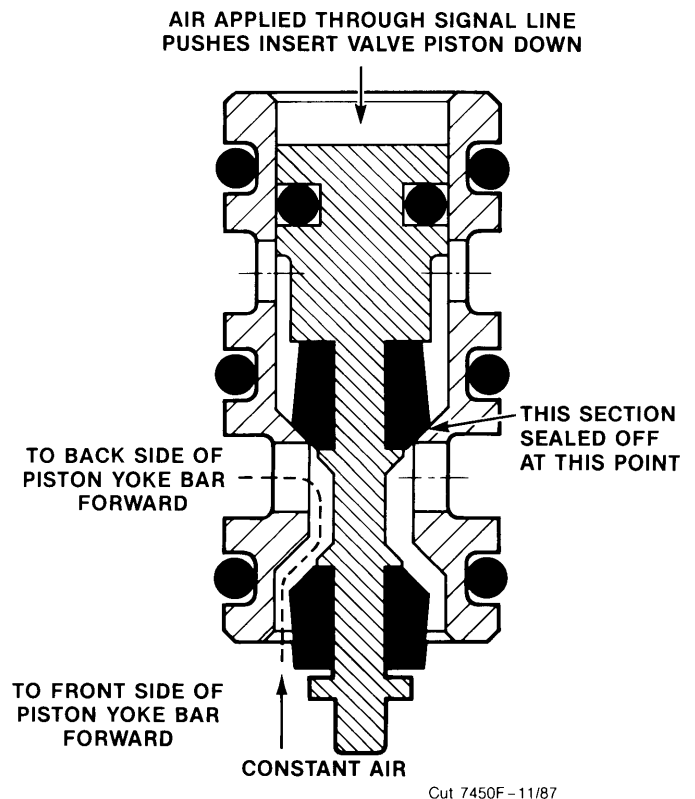

## RTO-15618 and RTLO-XX618 Models

### LO Range L

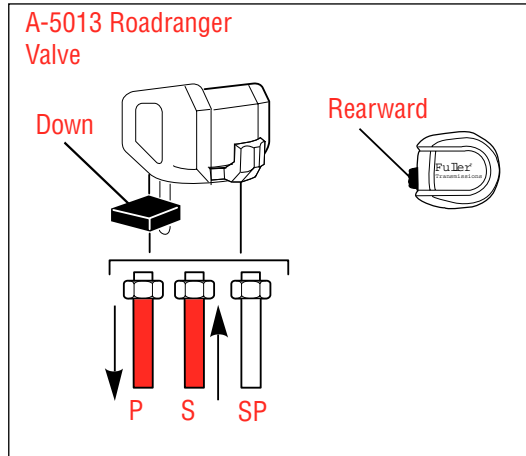

### Slave Valve Identification

A-5000 Valve

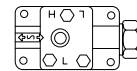

19470 Valve

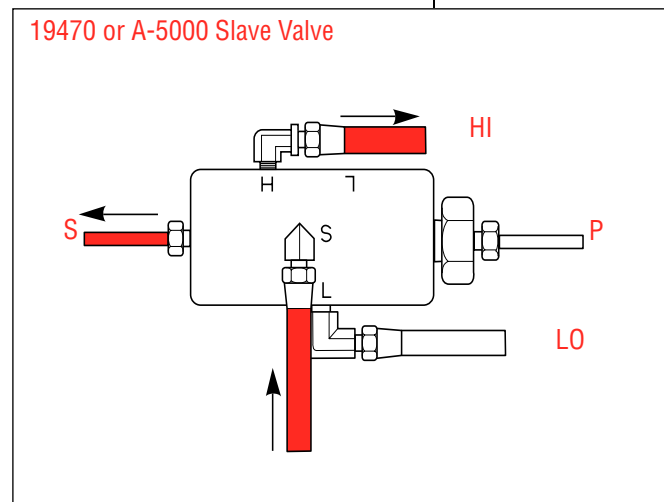
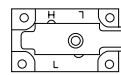

## Schematic

For all questions concerning removal and replacement, refer to Eaton Service and Parts Literature.

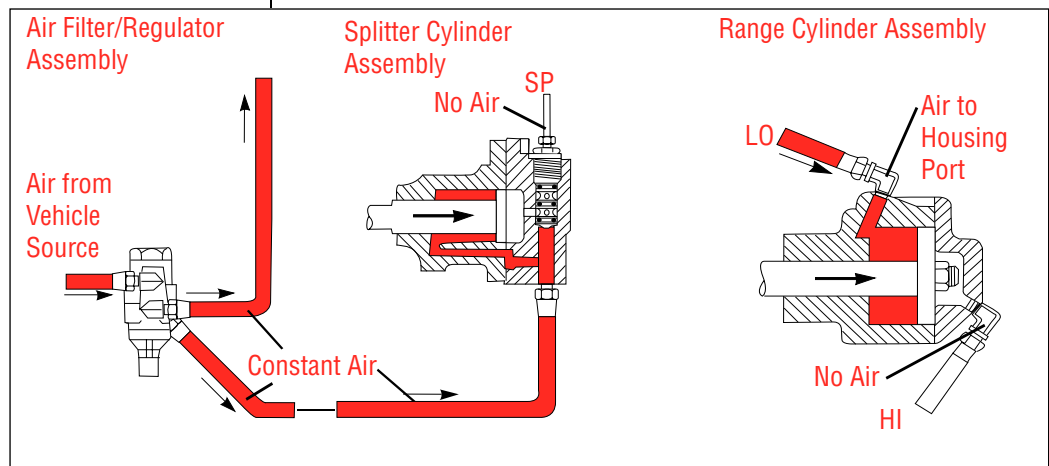

## RT0-15618 and RTLO-XX618 Models

### LO Range H

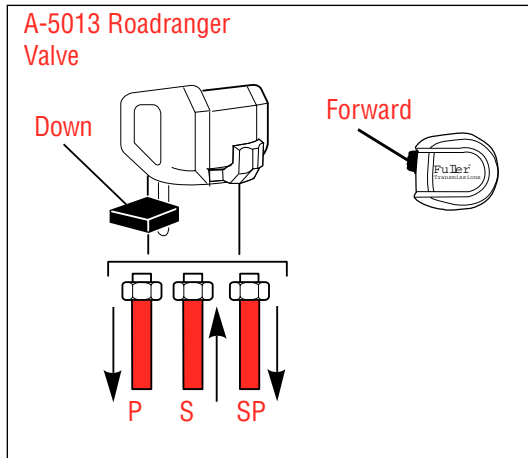

### Slave Valve Identification

A-5000 Valve

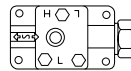

19470 Valve

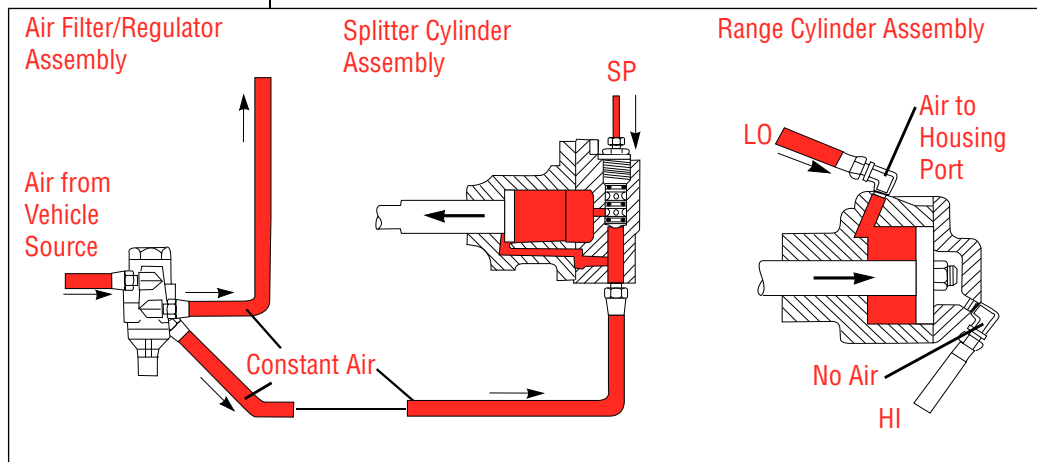
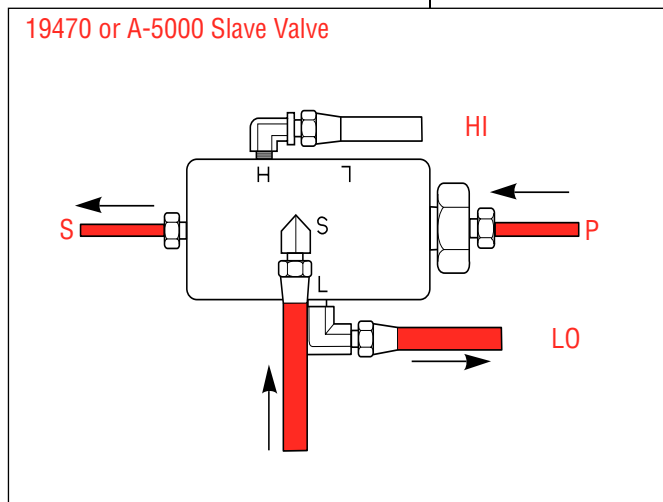
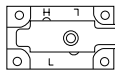

## Schematic

For all questions concerning removal and replacement, refer to Eaton Service and Parts Literature.

## RT0-15618 and RTLO-XX618 Models

HI Range L

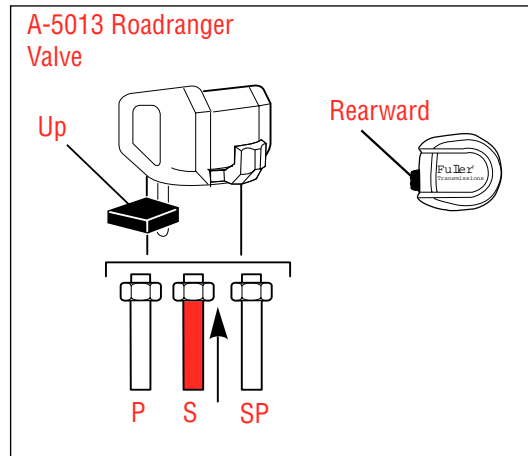

### Slave Valve Identification

A-5000 Valve

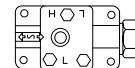

19470 Valve

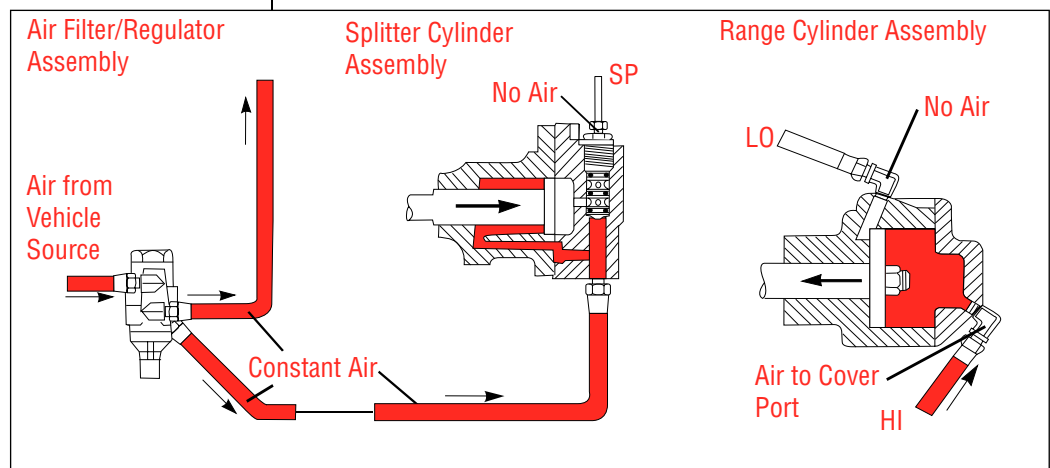
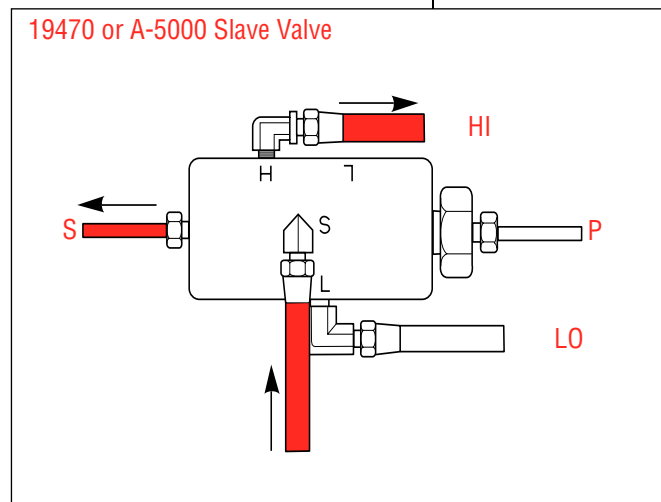
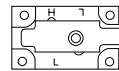

## Schematic

For all questions concerning removal and replacement, refer to Eaton Service and Parts Literature.

# RT0-15618 and RTLO-XX618 Models

## HI Range H

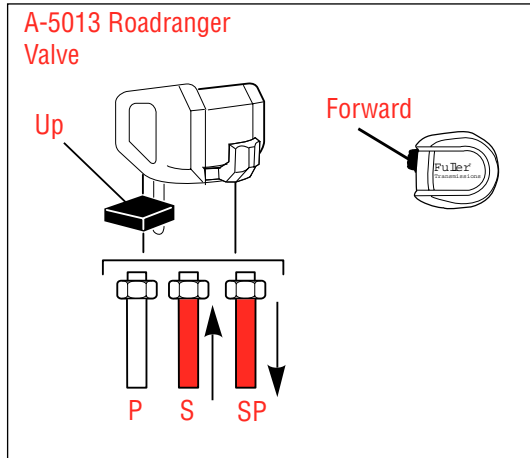

### Slave Valve Identification

A-5000 Valve

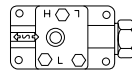

19470 Valve

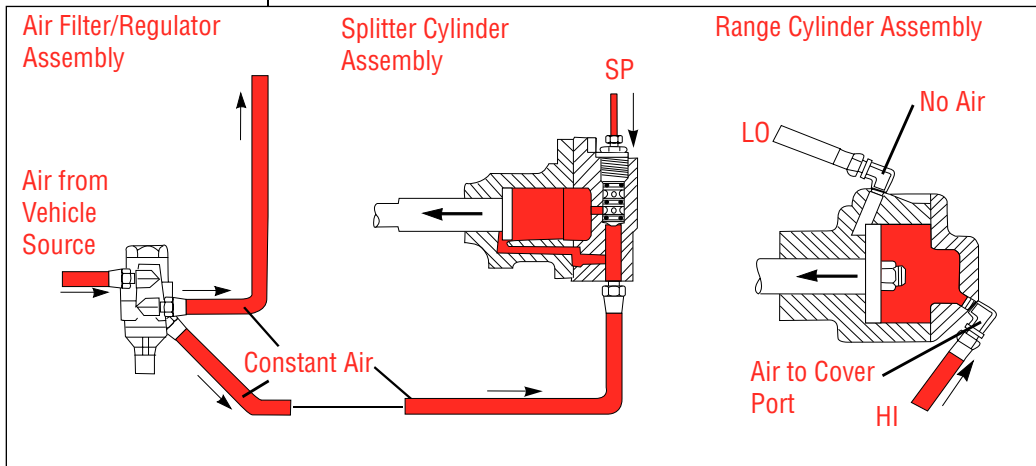
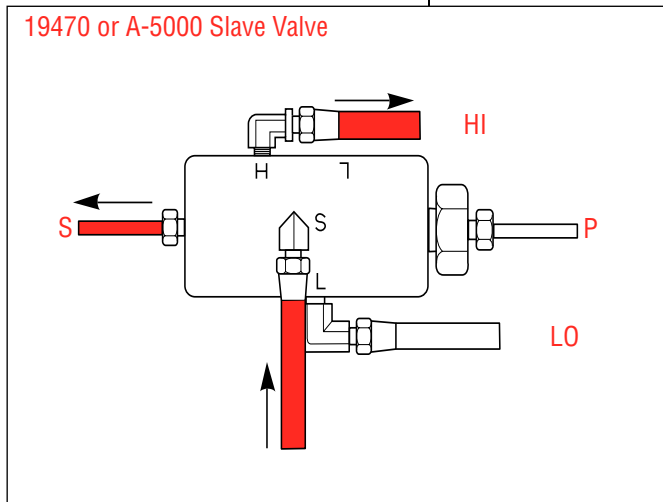
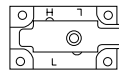

## Schematic

For all questions concerning removal and replacement, refer to Eaton Service and Parts Literature.

# DISASSEMBLY SHIFTING CONTROLS

## AIR SYSTEM

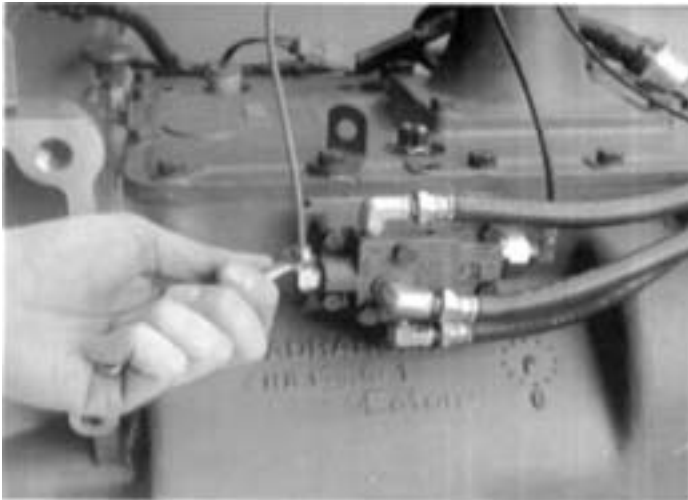

### A. Removal of Air Controls

1. Disconnect the two air lines at the "S" or Supply Port and "P" or End Port of the slave valve on the transmission case. Disconnect the three 1/4" rubber lines from the slave valve.

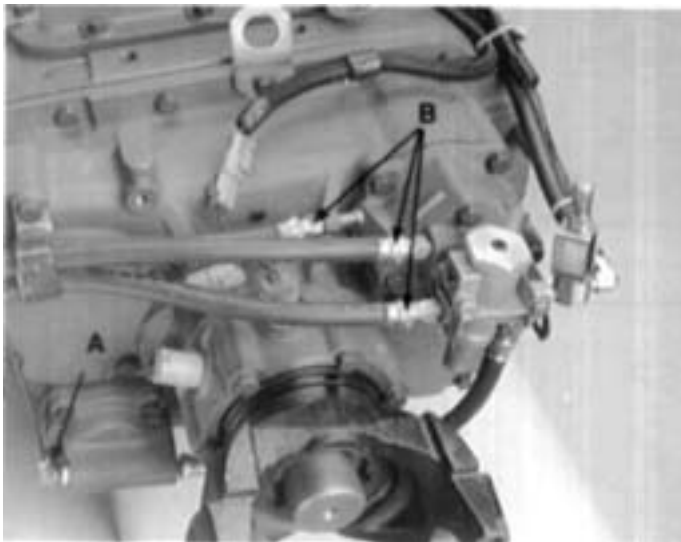

2. Remove the air line at the splitter cylinder cover (A). Then remove the three (3) 1/4 rubber lines at the range cylinder (B).

**NOTE:** If equipped with a shift lever the gear shift lever housing assembly can now be removed from shift bar housing by removing the four capscrews from the tower.

**NOTE:** The Roadranger valve mounted in the cab can be removed as shown.

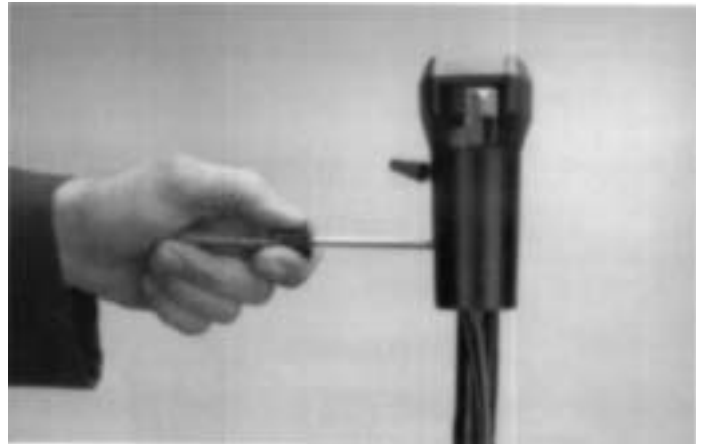

3. Turn out the two mounting screws in the Roadranger valve cover.



4. Slide the cover down to expose the valve ports and disconnect the three air lines.



5. Loosen the jam nut and turn the valve and nut from gear shift lever. Remove the valve cover, air lines, sheathing and O-rings from lever.



# DISASSEMBLY SHIFTING CONTROLS

---



6. Remove retaining capscrews on the shift bar housing which hold wiring harness clamps (left). Disconnect input speed sensor and engine speed sensor at wiring harness connectors (right).



7. Disconnect the 1/4" air hose at the inertia brake solenoid also disconnect the remaining air hose to the splitter cylinder (left). Remove the air hose at the inertia brake housing also disconnect the hydraulic valve wiring harness connector (right).

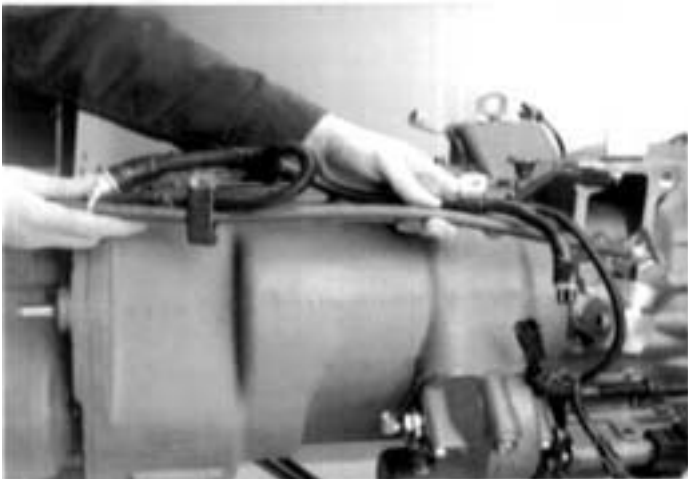

8. Remove the wiring harness and inertia brake air hose from the transmission.

## B. Removal of Air Filter/Regulator Assembly



Turn out the two cap screws and remove the air filter/regulator assembly.

**NOTE:** For disassembly and reassembly of Air Filter/Regulator Assembly, see Page 26.

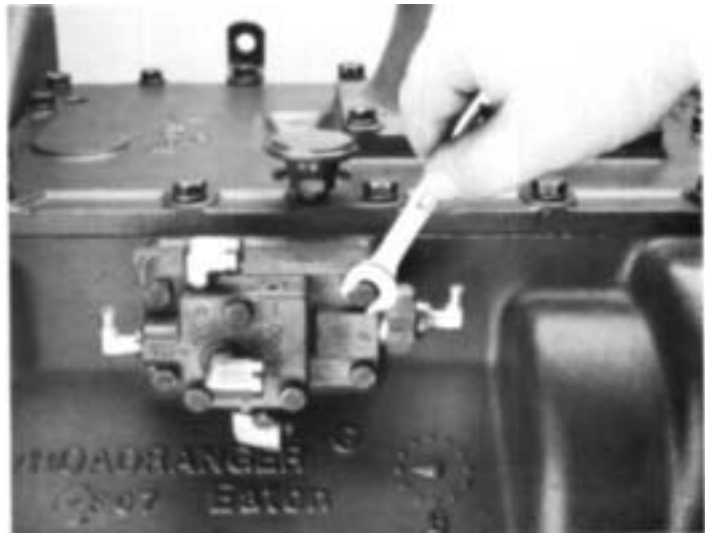

Turn out the four retaining cap screws and remove slave valve from transmission case.

# DISASSEMBLY SHIFTING CONTROLS

---

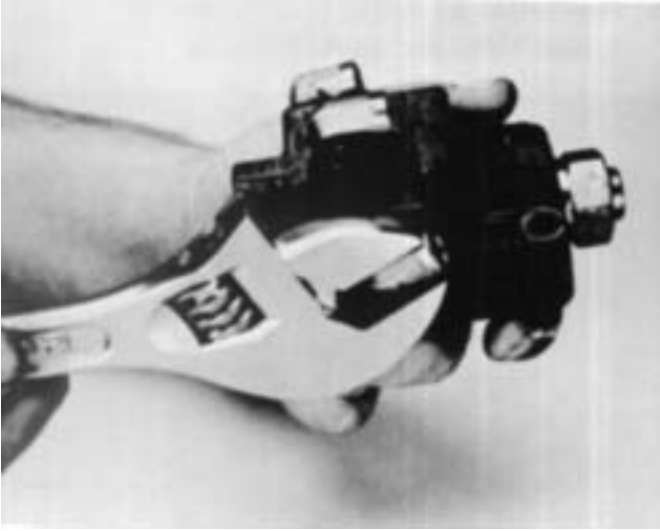

3. If necessary, remove the air line fittings from slave valve.

**NOTE:** For disassembly and reassembly of piston-type Slave Valve Assembly, see Page 26.

# DISASSEMBLY AND REASSEMBLY SHIFT BAR HOUSING

## SHIFT BAR HOUSING ASSEMBLY

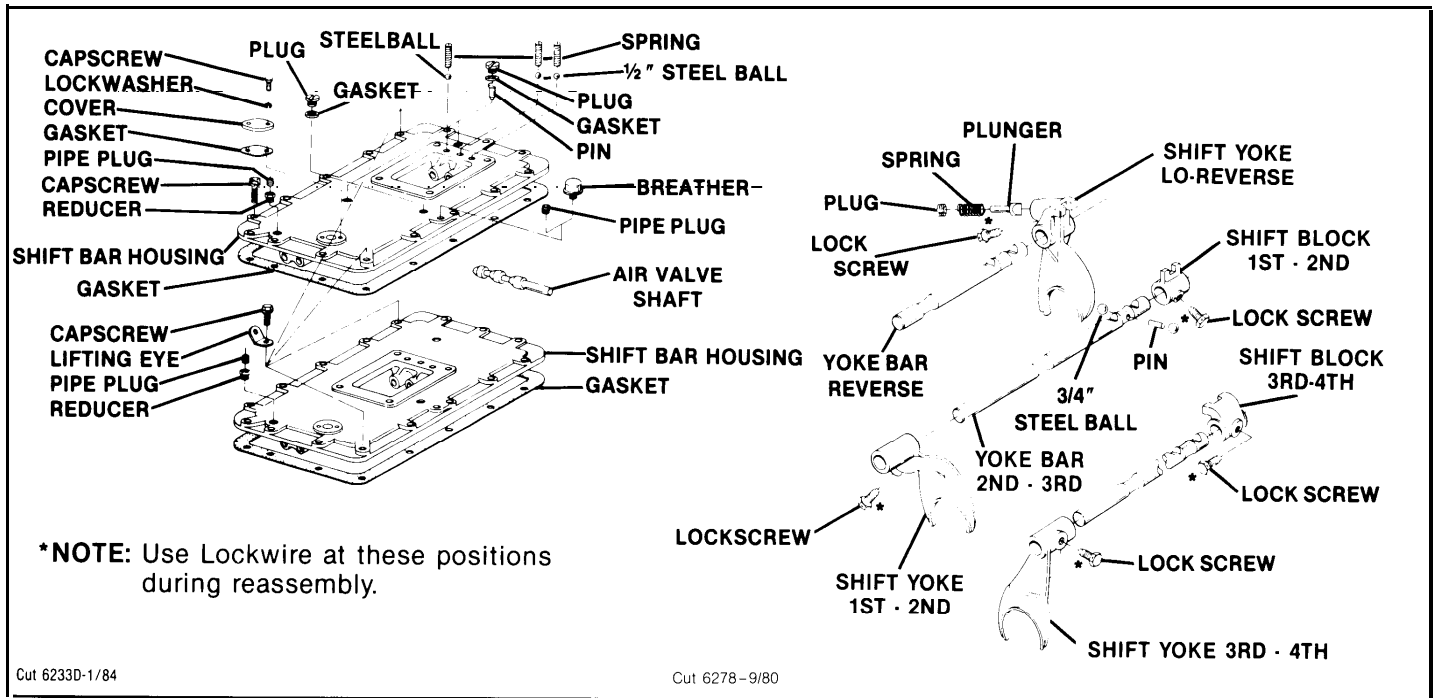

### A. Removal and Disassembly of the Shift Bar Housing Assembly

For models equipped with an Oil Pump and/or Cooler Assemblies, make sure to disconnect the lube line at the fitting on the shift bar housing before doing the following instructions.



1. Turn out the retaining capscrews. Jar the top to break the gasket seal and lift the shift bar housing from the transmission case. Remove the gasket.

**NOTE:** During disassembly, lay all parts on a clean bench in order of removal from the housing to make reassembly easier. Shift bars not being removed must be kept in the neutral position or the interlocking parts will lock the bars.



2. Tilt the assembly and remove the three sets of tension springs and balls from the housing bores.

# DISASSEMBLY AND REASSEMBLY SHIFT BAR HOUSING

---

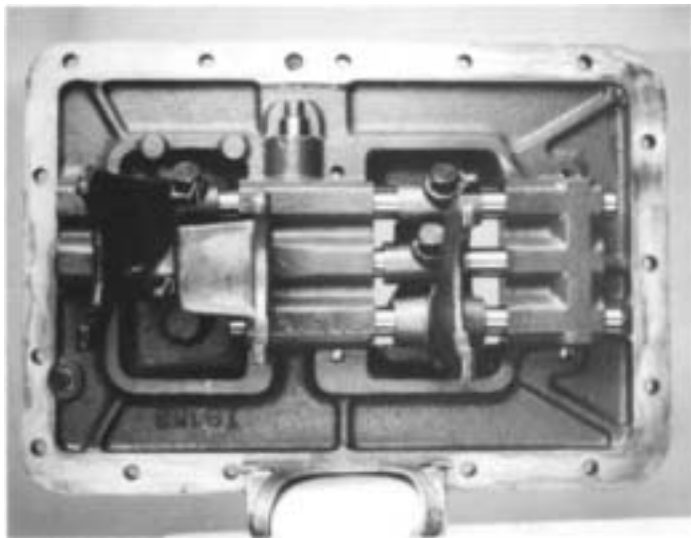

3. Secure the assembly in a vise with the plunger-side up. (The front of the housing will be to the left.) For models so equipped, cut the lockwire and turn out the retaining capscrews to remove the oil trough from the housing.

**NOTE:** Start with the upper shift bar, move all bars to the right and out the rear boss bore. Cut the lockwire and remove the lockscrews from each bar just before their removal.

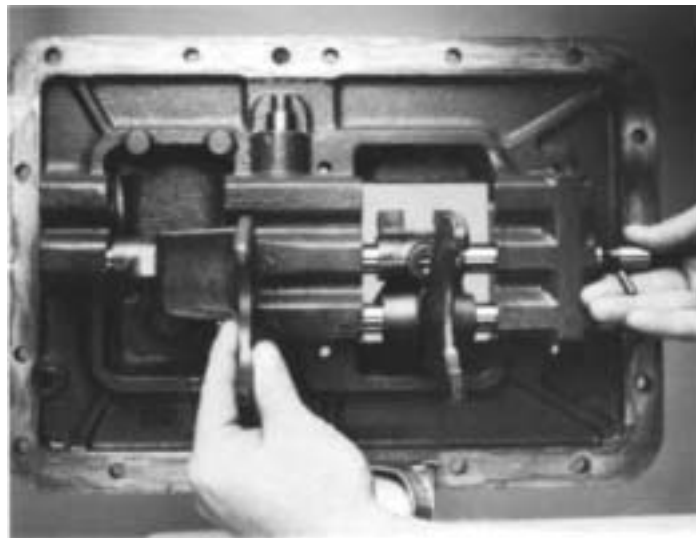

5. Move the 1st-2nd speed shift bar to the housing rear, removing the yoke and block from the bar. As the neutral notch in the bar clears the rear boss, remove the small interlock pin from the bore.

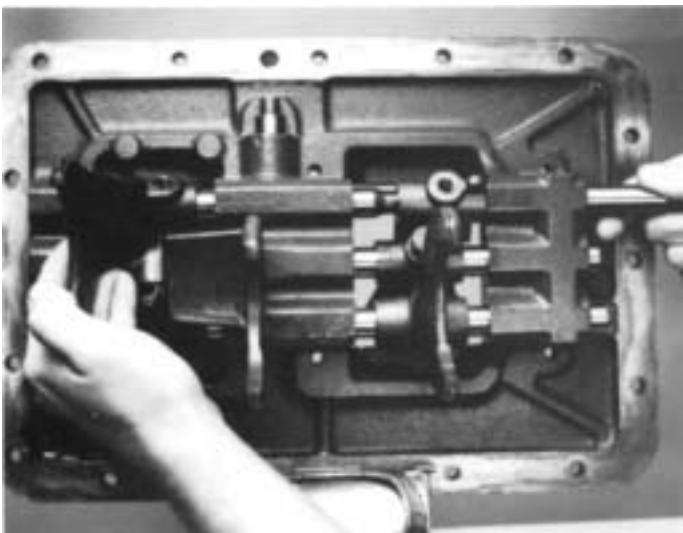

4. Move the 3rd-4th speed shift bar to the housing rear, removing the yoke and block from the bar.

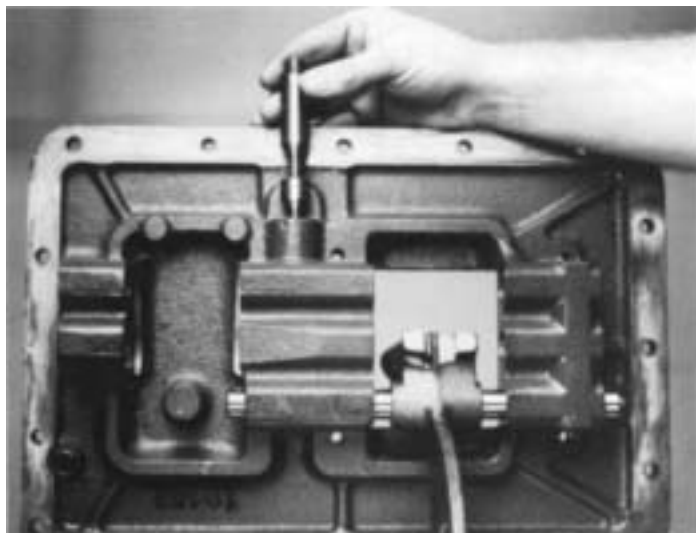

6. Remove the actuating plunger from the center boss bore.

# DISASSEMBLY AND REASSEMBLY SHIFT BAR HOUSING

## B. Reassembly of the Shift Bar Housing Assembly.

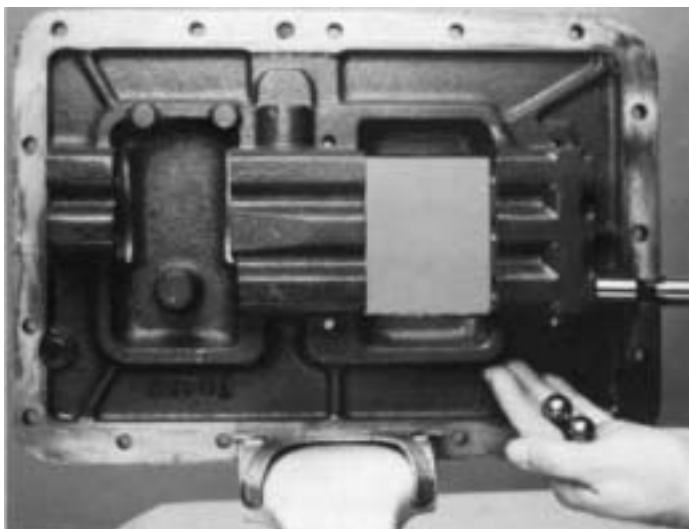

7. Move the short LO-Reverse speed shift bar to the housing rear, remove the yoke from the bar. As the shift bar is removed from the housing, two 3/4 interlock balls will drop from the rear boss bottom bore.



8. If necessary, remove the plug, spring, and reverse-stop plunger from the LO-Reverse speed shift yoke bore.



1. If previously removed, install the reverse-stop plunger in the LO-Reverse shift yoke, making sure the plunger is fully seated in the yoke slot bore.



2. Install the spring in the yoke bore and on the plunger shank.

# DISASSEMBLY AND REASSEMBLY SHIFT BAR HOUSING

---



3. Install the plug and tighten to compress the spring (left). Back the plug out 1 - 1 1/2 turns and stake the plug through the small hole in the yoke (right.)

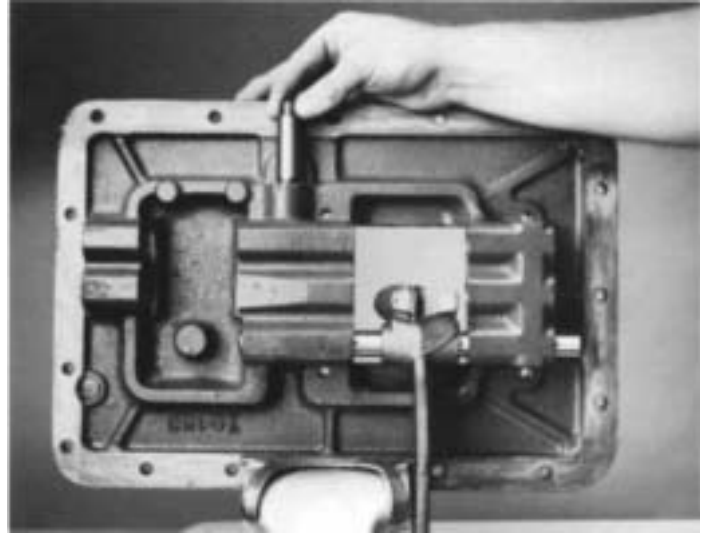

5. While holding the plunger shank, install the actuating plunger in the center boss bore.

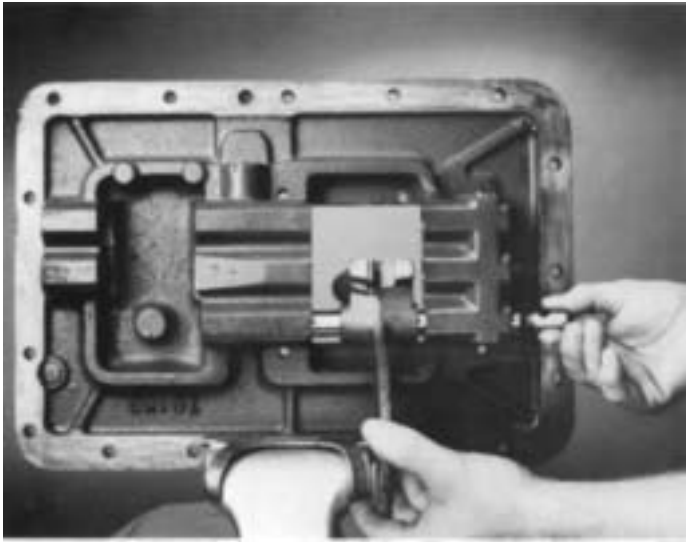

4. Secure the shift bar housing in a vise. Hold the notched-end of the short LO-Reverse speed shift bar, install the bar in the lower bore of the shift bar housing bosses. Install the yoke lock screw, tighten and wire securely.

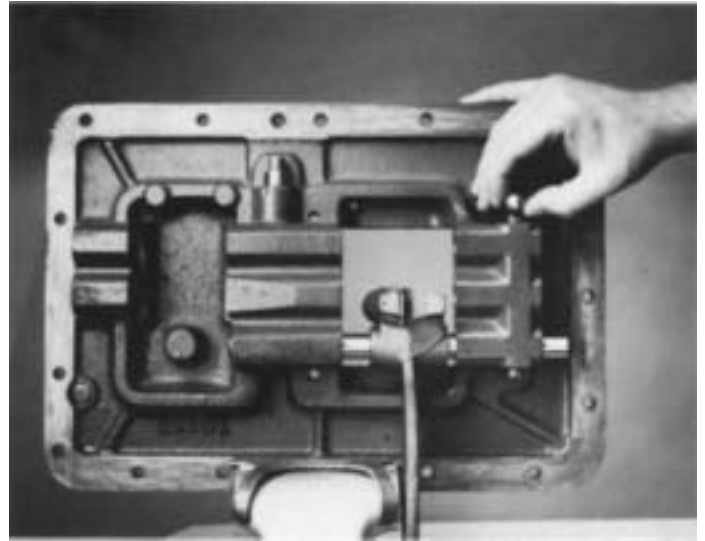

6. Install one 3/4" interlock ball in the rear boss top bore. This ball rides between LO-Reverse and 1st-2nd speed shift bars.

**NOTE:** Start with the lower shift bore of the rear boss and move to the left (front of the housing). Keep bars in the neutral position during installation. DO NOT EXCEED the recommended torque ratings for the yoke lock screws as over-tightening may distort the shift bars.

# DISASSEMBLY AND REASSEMBLY SHIFT BAR HOUSING

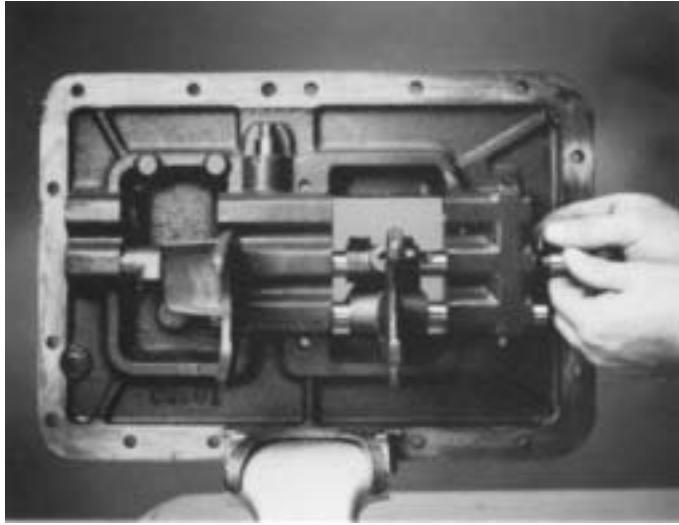

7. While holding the notched-end of the bar, install the 1st-2nd speed shift bar in the housing boss middle bore. Position the shift block on the bar between the center and rear bosses, and the yoke on the bar between the front and center bosses, long hub to the housing front. Just before inserting the notched-end of the rear boss bar, install the small interlock pin VERTICALLY in the neutral notch bore. Install the block and yoke lock screws, tighten, and lockwire securely.

**NOTE:** It is necessary that the interlock pin remain in a vertical position during reassembly as rotation of the bar causes the pin to jam in the tension spring bores.

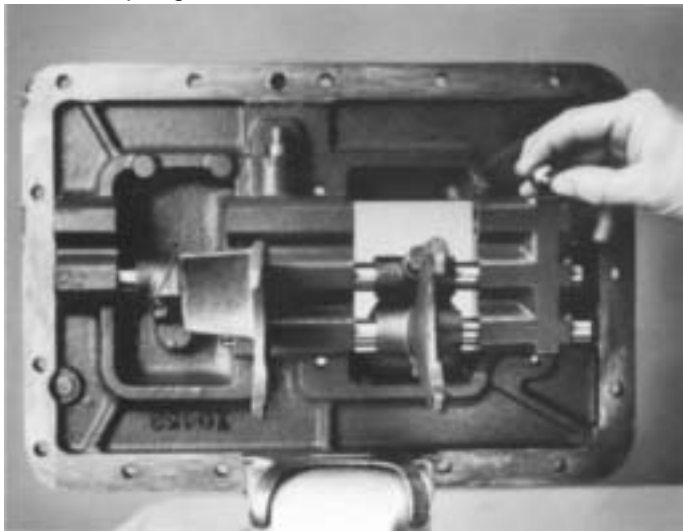

8. Install the other  $\frac{3}{4}$ Ø interlock ball in the rear boss top bore. This ball rides between the 1st-2nd and the 3rd-4th speed shift bars.

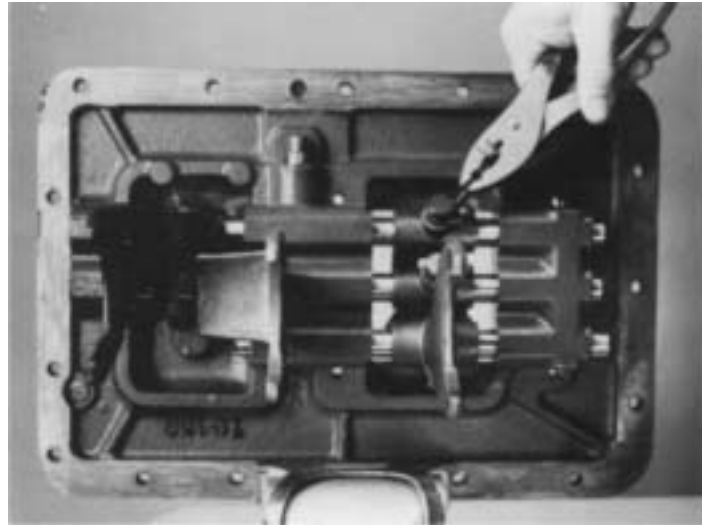

9. While holding notched-end of the bar, install the 3rd-4th speed shift bar in the housing boss upper bore, position the shift block on the bar between the front and center bosses, long hub to the housing rear. Install the block and yoke lock screws, tighten, and lockwire securely.
10. For models so equipped, install the oil trough on the housing. Tighten the capscrews and lockwire securely.

# DISASSEMBLY AND REASSEMBLY SHIFT BAR HOUSING

---

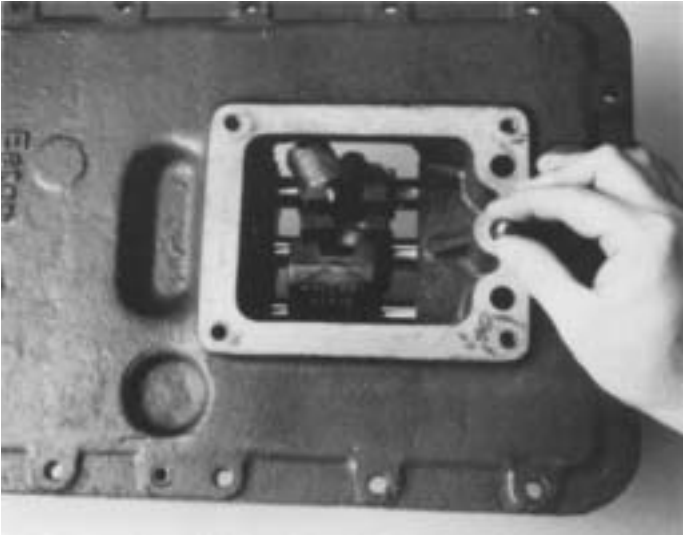

**11.** Remove the assembly from the vise. Install the three tension balls, one in each bore on the housing top.

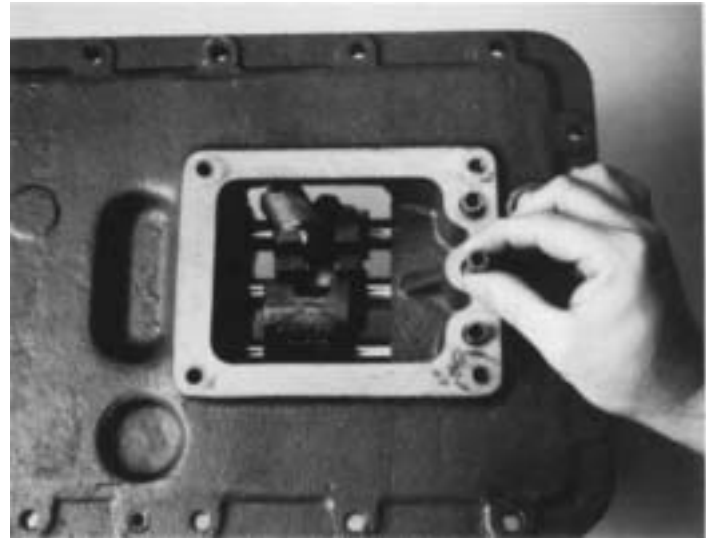

**12.** Install the three tension springs, one over each ball in the housing bores.



# REMOVAL - OUTPUT YOKE, AUXILIARY SECTION, AND TORQUE CONVERTER HOUSING

## A. Removal of the Output Yoke

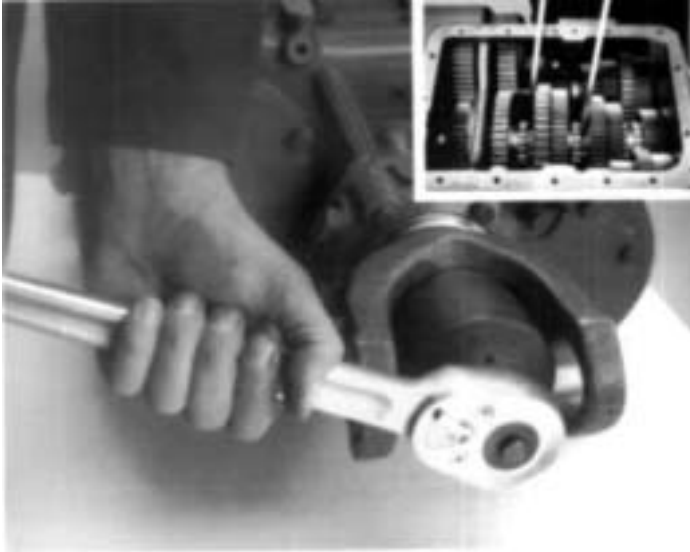

1. Lock transmission by engaging two mainshaft gears with the mainshaft sliding clutches (inset.) Use a large breaker bar to turn the output shaft nut from the output shaft.



2. Pull yoke straight to the rear and off the output shaft.

## B. Removal of the Auxiliary Section

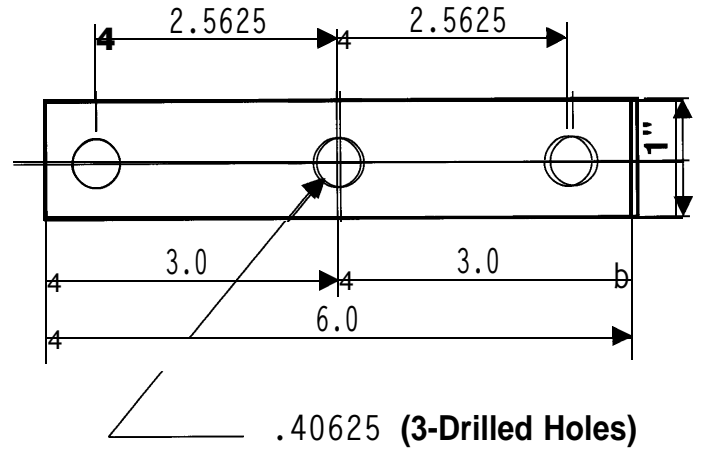

Bar Stock - 3/8" x 1"  
Tool Print T-65853

1. Place the transmission in the vertical position. Put blocks under the torque converter housing to prevent damage to the torque converter. Removal can also be completed in the horizontal position.



2. Remove the four capscrews and the auxiliary countershaft rear bearing cover, gasket, and rear bearing shim.

# REMOVAL - OUTPUT YOKE, AUXILIARY SECTION, AND TORQUE CONVERTER HOUSING

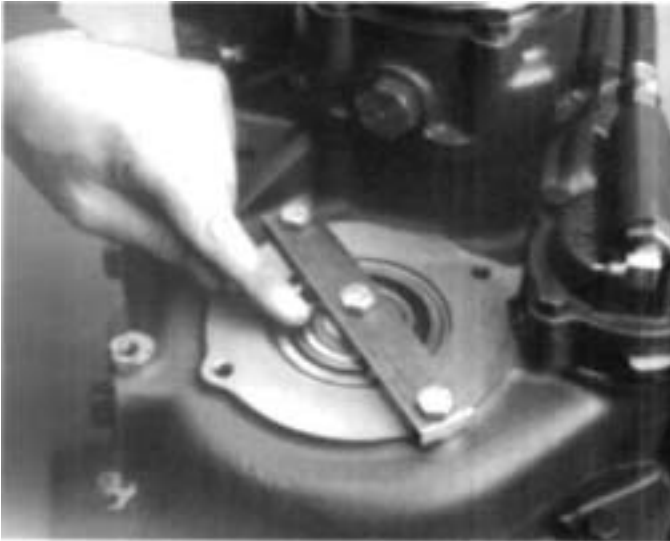

**CAUTION** Auxiliary Countershaft Retaining Straps may be installed to hold countershaft in place. Auxiliary can be removed without straps, use caution.

3. Install an Auxiliary Countershaft Retaining Strap with 3- 3/8" x 1" clean capscrews. Place a flat washer under the strap to prevent damage to the rear auxiliary countershaft bearing.

**WARNING** Do not use an air gun. Tighten by hand until the capscrews are snug.

4. Repeat Steps 2 and 3 for the remaining auxiliary countershaft.



5. Remove the nineteen capscrews that hold the auxiliary section to the transmission case.

**NOTE:** There are three lengths of capscrews, note their location.



6. Insert three capscrews in the tapped holes of housing flange. Tighten evenly to move auxiliary section to the rear and just far enough from front section to break gasket seal.

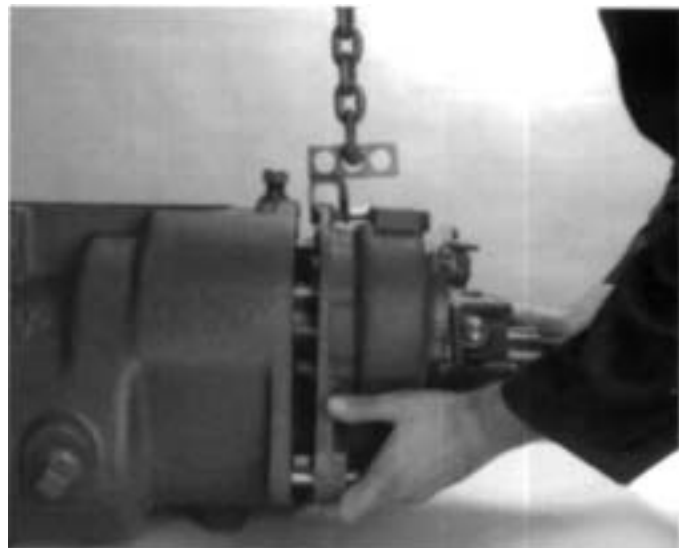

7. Remove capscrews and attach a chain hoist to auxiliary section. Move the assembly to the rear until free of front section and remove gasket.

# REMOVAL - OUTPUT YOKE, AUXILIARY SECTION, AND TORQUE CONVERTER HOUSING



8. The auxiliary section can also be removed with the transmission set in the vertical position. Remove the retaining capscrews from the housing flange and lift the assembly from the front section. Remove the gasket.

## C. Removal Torque Converter

**NOTE:** The transmission rear must be blocked so the two aligning pins on the transmission rear case are not damaged. If the auxiliary section is not being removed the transmission can be placed vertically on a stand using an output flange or half round yoke affixed to a large plate.

**CAUTION** Care must be taken when placing the transmission in the vertical position. Always use safety chains on transmission. Assure that transmission is stable in vertical position before removing the safety chains.



Remove the retaining capscrews from the convertor pilot.



Use the two (2) threaded capscrew holes to separate the converter pilot from the torque converter (Left). Remove the converter pilot from the torque converter (Right).

# REMOVAL - OUTPUT YOKE, AUXILIARY SECTION, AND TORQUE CONVERTER HOUSING

---



3. If required the pilot o-ring or hydraulic seals can be serviced at this time.



5. Install 2 lifting eyes into the converter pilot capscrew holes, attach lifting chain and remove converter straight up from the converter housing.

**NOTE:** Torque converter assembly is Non-Servicable. Do not attempt to disassemble. It will be returned for service and replaced as a complete assembly.

## D. Removal of the Hydraulic Valve

**NOTE:** If not previously removed the transmission dip stick and tube can be removed from the oil pan at this time.

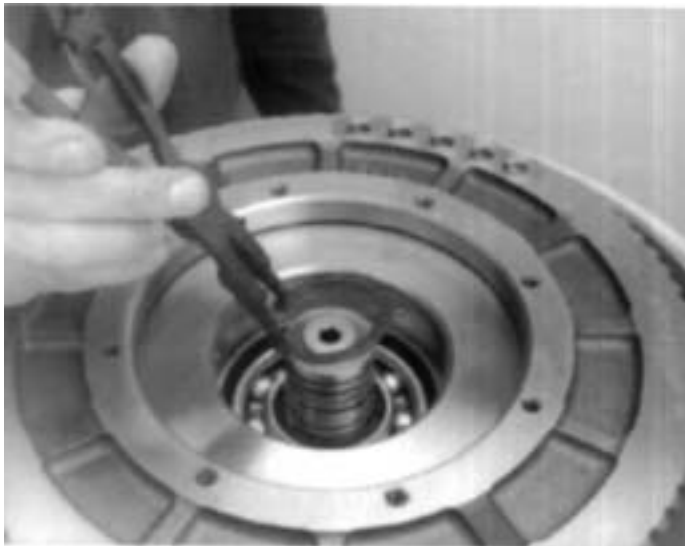

4. Remove the torque converter snap ring from the input shaft.

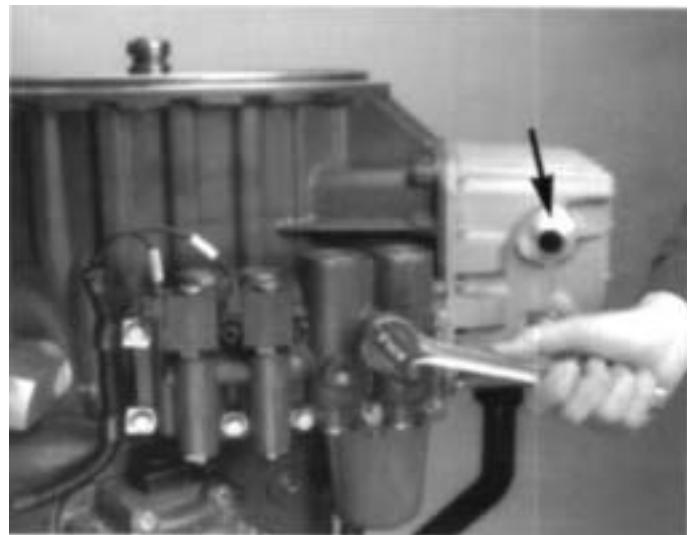

6. Loosen and remove the ten (10) retaining cap screws from the hydraulic valve assembly. Note the location of the two (2) allen head cap screws for reassembly.

# REMOVAL - OUTPUT YOKE, AUXILIARY SECTION, AND TORQUE CONVERTER HOUSING



2. Remove the hydraulic valve assembly from the torque converter housing. (Left) Separate the 2 gaskets and mounting plate from the hydraulic valve. (Right)



3. If necessary the electronic solenoids can be removed from the hydraulic valve at this time.

**NOTE:** The hydraulic valve is a **NON-SERVICABLE** assembly. **DO NOT DISASSEMBLE**, it will be returned for service.

## E. Removal of oil pan, oil pick-up and screen and oil filter assembly.

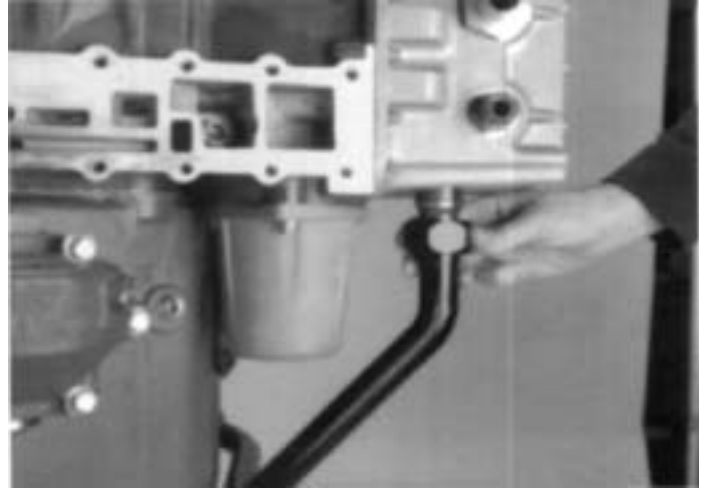

1. Disconnect and remove the oil sump return line from the oil pan.

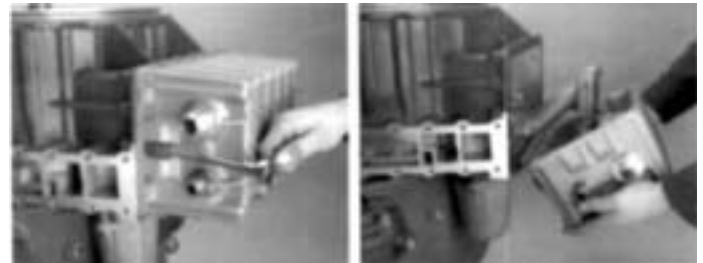

2. Loosen and remove the retaining cap screws from the oil pan (Left). Remove the oil pan from the bottom of the torque converter housing (Right).



3. Remove the two (2) retaining capscrews from the oil pick-up. Remove the pick-up and screen and oil pan gasket from the torque converter housing.

# REMOVAL - OUTPUT YOKE, AUXILIARY SECTION, AND TORQUE CONVERTER HOUSING



4. Loosen and remove the three retaining capscrews from the oil filter housing. Change the oil filter as recommended. Service the sealing ring if required.

## F. Removal of the torque converter housing



1. Loosen and remove the six (6) retaining capscrews from the stator support.

**NOTE:** The stator support may be set in place a soft face mallet or pry bar may be required to loosen the stator support. The stator support is a **NON-SERVICABLE** assembly.



2. Remove the stator support and gasket



3. Remove the four (4) retaining capscrews and six (6) retaining nuts from the torque converter housings.

# REMOVAL - OUTPUT YOKE, AUXILIARY SECTION, AND TORQUE CONVERTER HOUSING

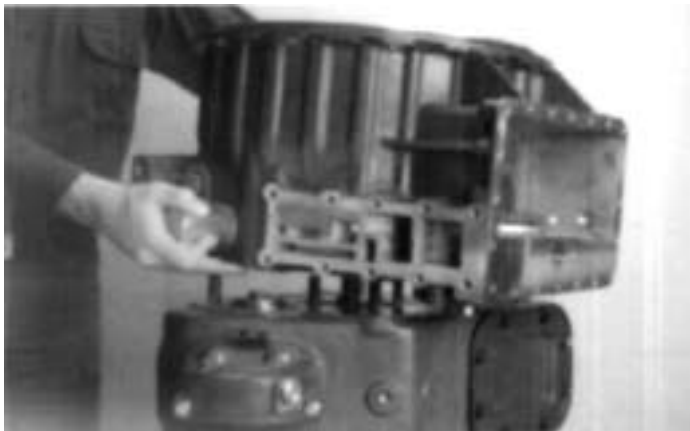

4. Jar the torque converter housing to break the seal remove the torqueconverter housing and gasket from the transmission case.



5. Block the oil pump drive gear to loosen retaining nut from oil pump shaft.



6. Remove the oil pump drive gear and retaining nut from the torque converter housing.



7. Loosen and remove the two (2) retaining capscrews from the oil pump assembly (Left). Remove the oil pump from the torque converter housing (Right).

**NOTE:** The oil pump is a **NON-SERVICABLE** assembly and should be returned for service. The two (2) oil pump o-rings can be serviced at this time if necessary.

## G. Removal of the Inertia Brake



1. Loosen the six (6) retaining capscrews form the Inertia Brake Housing.



2. Remove the retaining capscrews from the assembly and remove from the transmission case.

# REMOVAL - OUTPUT YOKE, AUXILIARY SECTION, AND TORQUE CONVERTER HOUSING

## H. Removal of Hydraulic Pressure Valves



1. The pressure relief valve is located in the torque converter housing oil pan sump area.

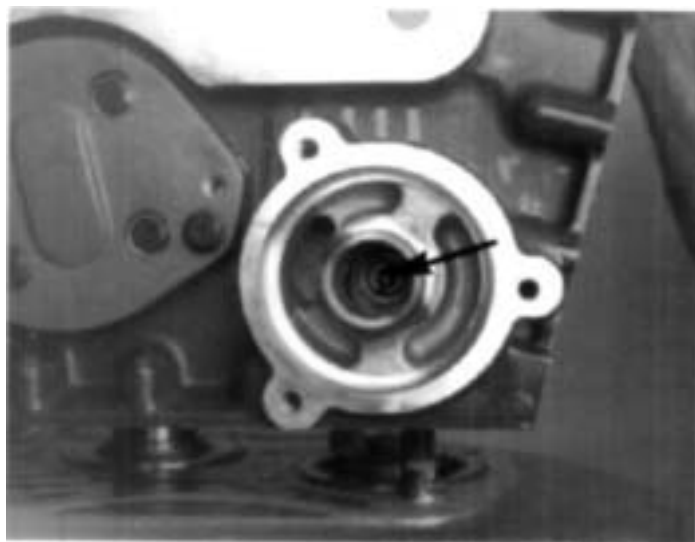

2. To service the pressure relief valve, reach into the oil filter mounting adapter and remove the valve. The valve is NON-SERVICEABLE. Replacement is required.

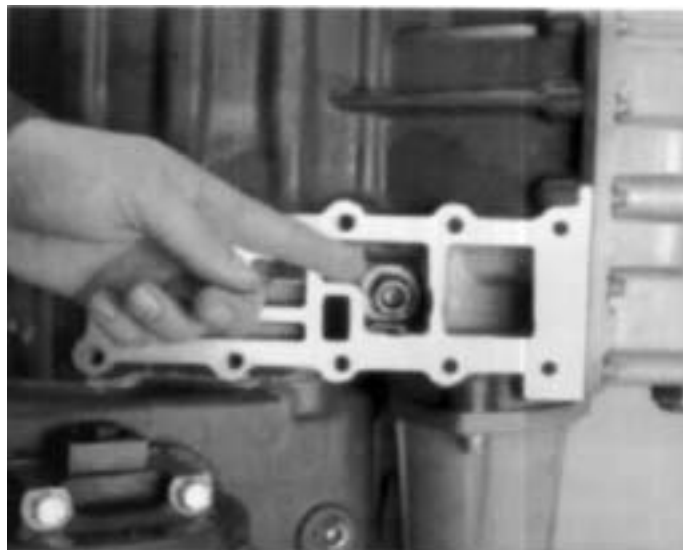

3. The filter by-pass valve is located inside the hydraulic valve main lube passage. Service of the valve is thru the main lube passage, the valve is **NON-SERVICEABLE** and replacement is required.



# DISASSEMBLY - AUXILIARY SECTION

## SPLITTER CYLINDER ASSEMBLY

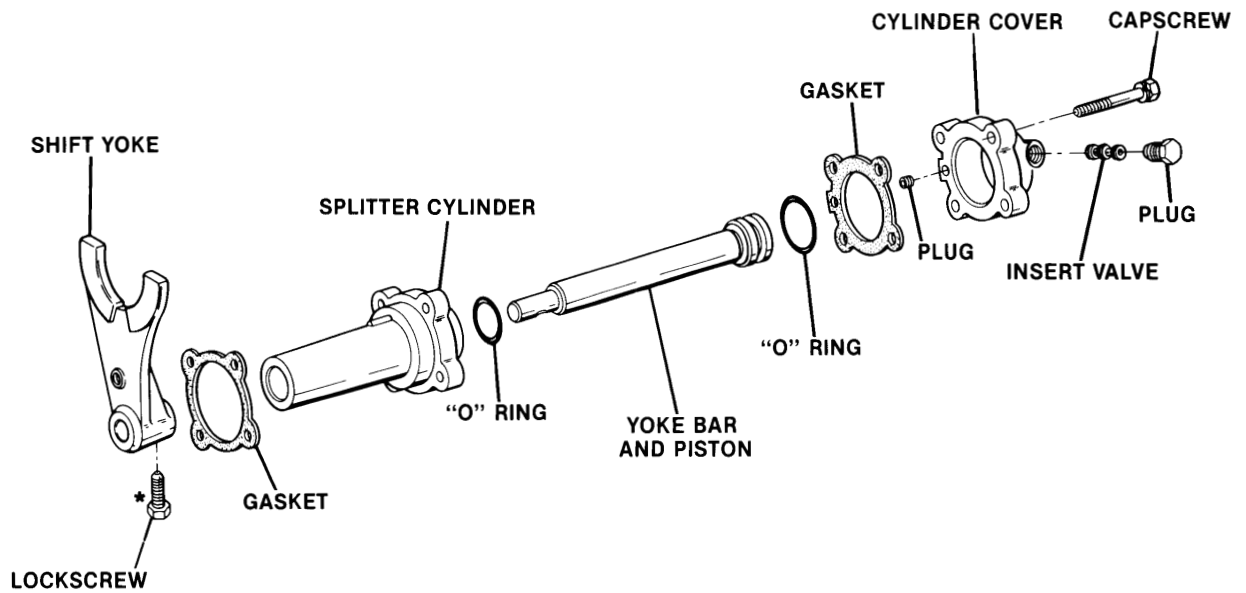

Cut 6441 - 3/87

\*Note: Use lock wire at this position

### A. Removal and Disassembly Rear Auxiliary Drive Gear and Yoke



1. Cut the lockwire on the splitter yoke retaining bolt and loosen the bolt.



2. Remove the retaining bolt, splitter yoke and sliding clutch assembly from the auxiliary section.

# DISASSEMBLY - AUXILIARY SECTION

## AUXILIARY MAINSHAFT ASSEMBLY

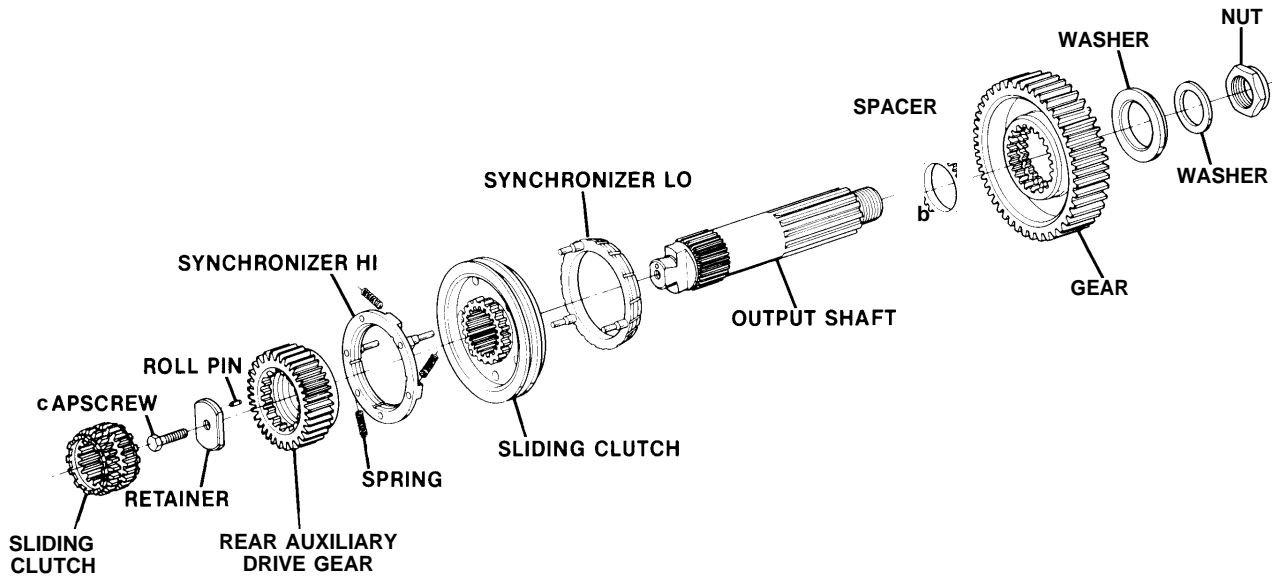

Cut 6593 L-4/87

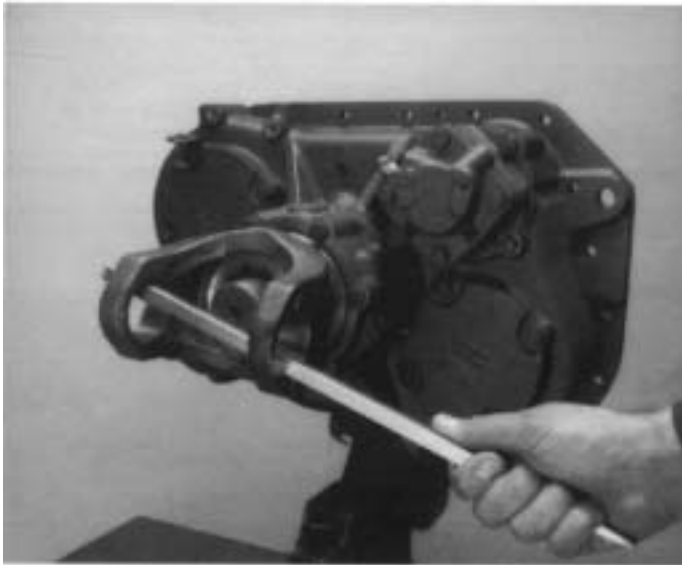

3. Temporarily install an output yoke on the output shaft and secure it by placing a bar through the yoke.



4. Break loose the 15/16 $\bar{n}$  retaining capscrew on the front of the output shaft.

# DISASSEMBLY - AUXILIARY SECTION

## AUXILIARY COUNTERSHAFT ASSEMBLY

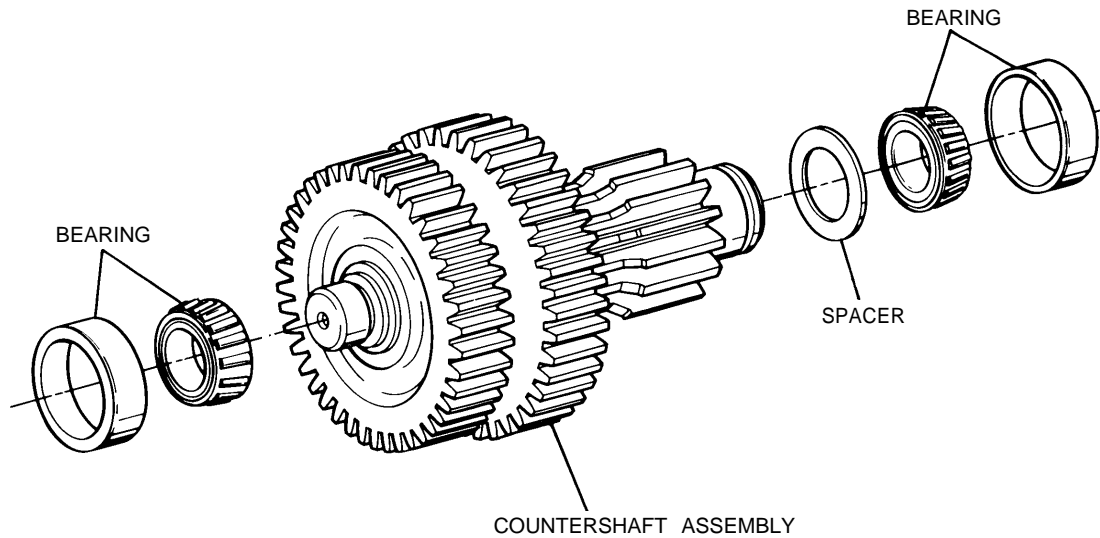

Cut 6503M - 11/91

## B. Removal of the Auxiliary Countershaft Assemblies

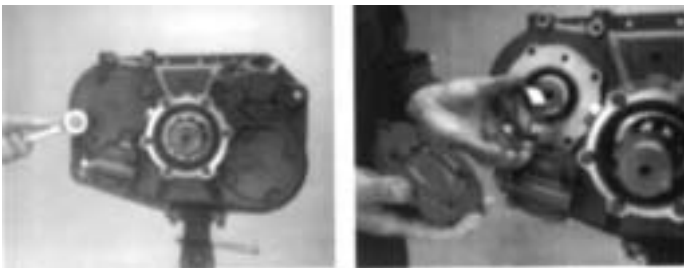

1. Secure the auxiliary housing in a vise. Remove the auxiliary countershaft retaining straps or rear bearing covers, shim and rear bearing race.

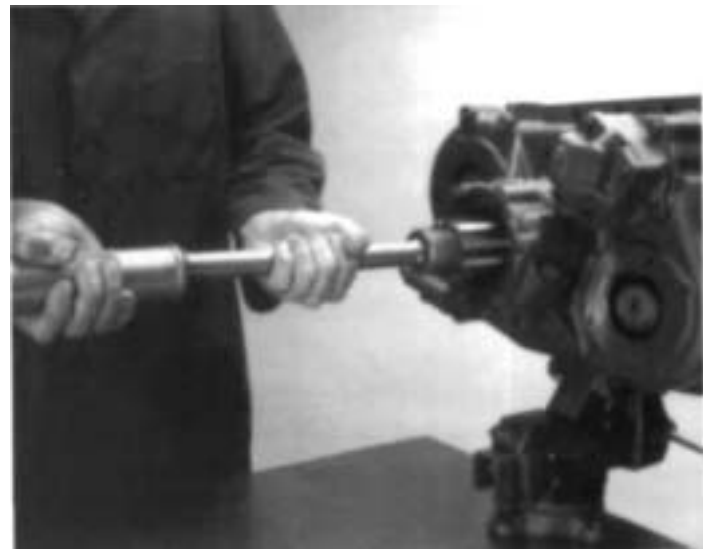

**WARNING** The countershaft will fall loose in the auxiliary section, but will not fall out of auxiliary section.

2. Use a soft bar and maul to partially drive the output shaft forward.

# DISASSEMBLY - AUXILIARY SECTION

---

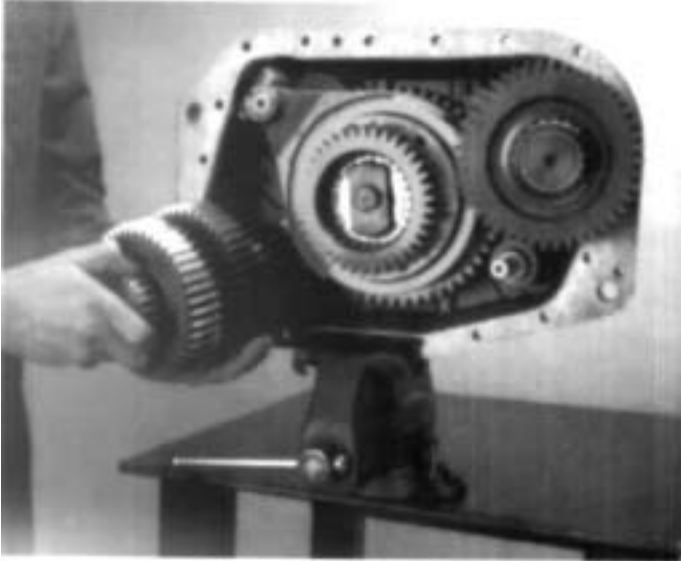

3. Remove the auxiliary countershaft from the auxiliary section case.

## C. Removal Rear Auxiliary Drive Gear Assembly

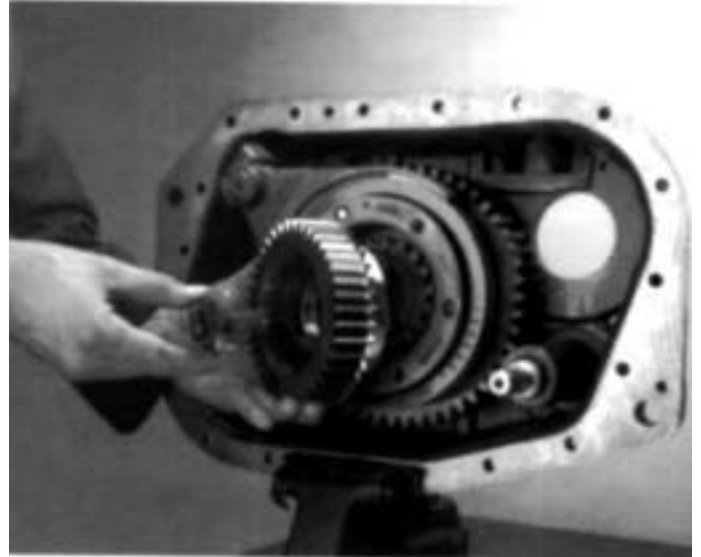

1. Remove the 15/16" retaining capscrew, retainer and auxiliary drive gear from the auxiliary section.



4. If necessary, secure the countershaft assemblies in a vise and remove both the front and rear bearings with a bearing separator and jaw pullers.

# DISASSEMBLY - AUXILIARY SECTION

## RANGE CYLINDER ASSEMBLY

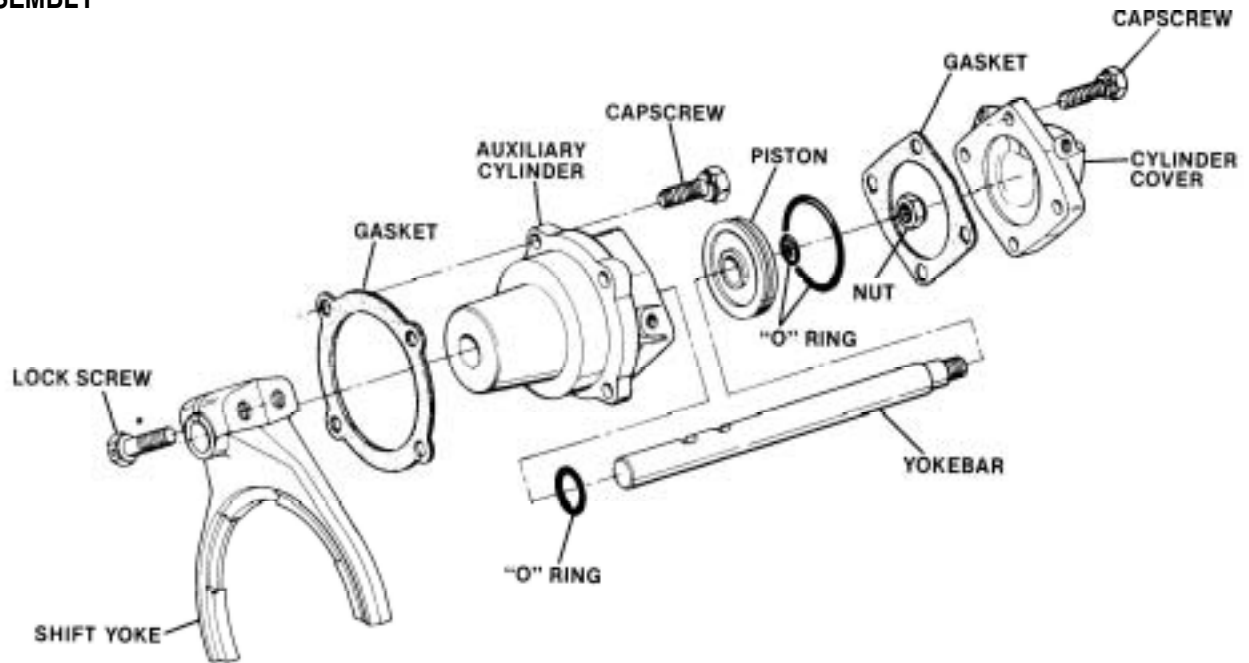

Cut 6427-5/83

\*Note: Use lockwire at this position

### D. Removal and Disassembly of Range Cylinder Assembly.

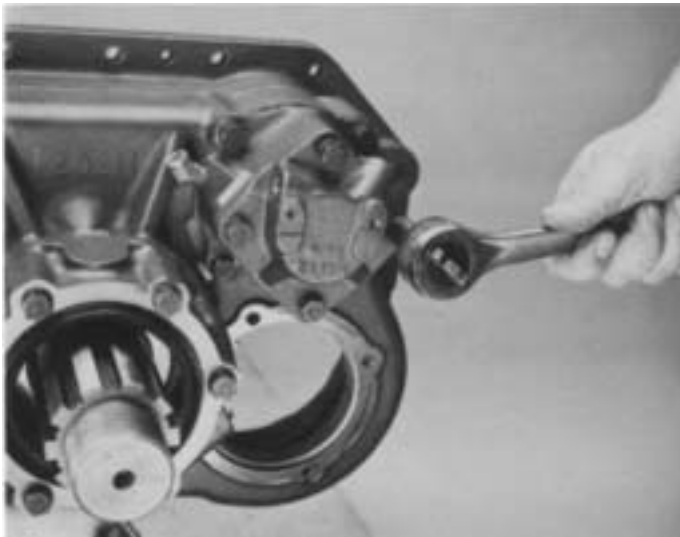

1. Remove the capscrews, range cylinder cover, and gasket.

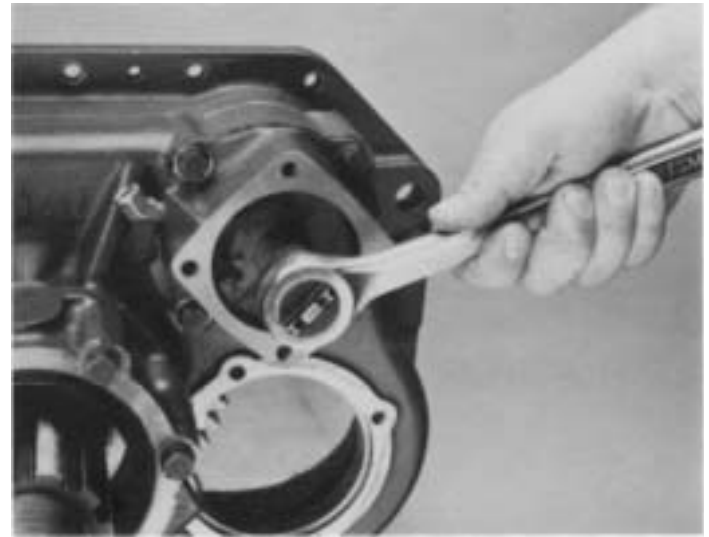

2. Remove nut from yoke bar.

# **DISASSEMBLY-AUXILIARY SECTION**

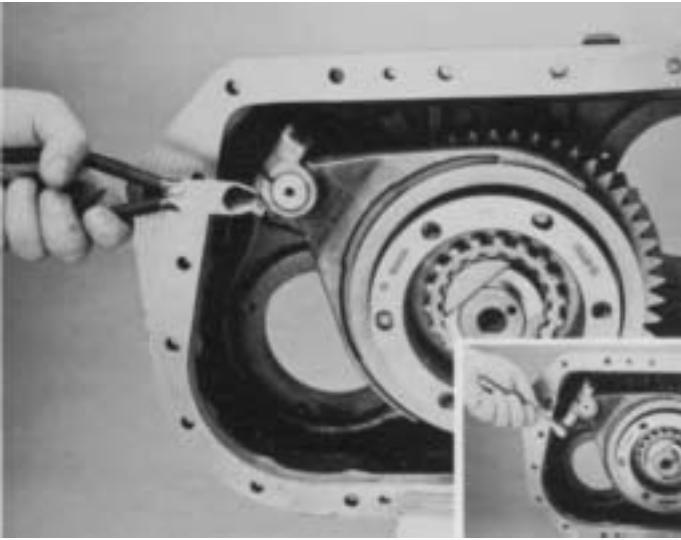

3. Cut the lockwire. Remove the two 3/4" yoke lock-screws (inset).

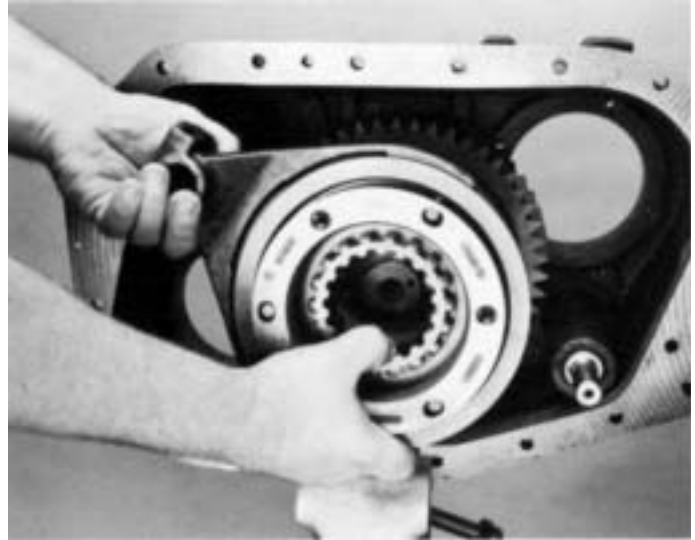

5. Remove the shift yoke and synchronizer assembly from output shaft.

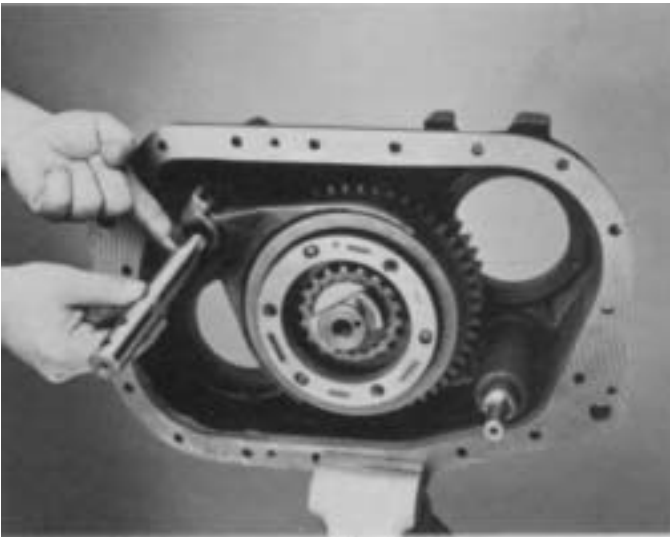

4. Pull the yoke bar from the cylinder housing bore.

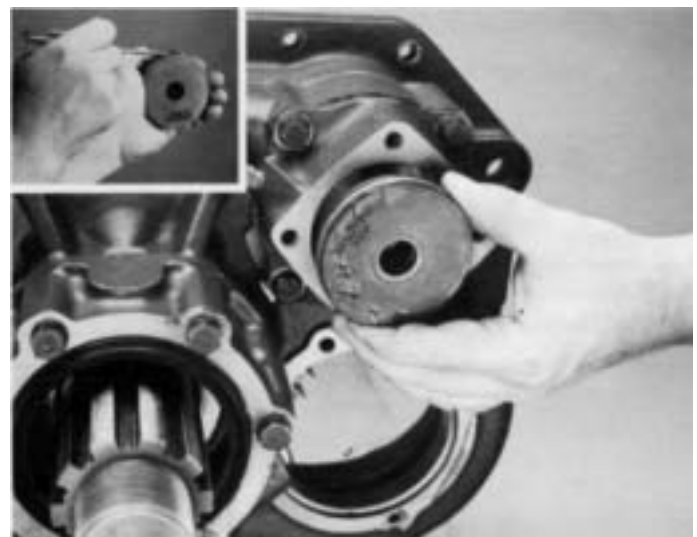

6. Remove the range piston from the cylinder bore. If necessary, remove the O-rings from the position I.D. and O.D. (inset).

# DISASSEMBLY-AUXILIARY SECTION

---

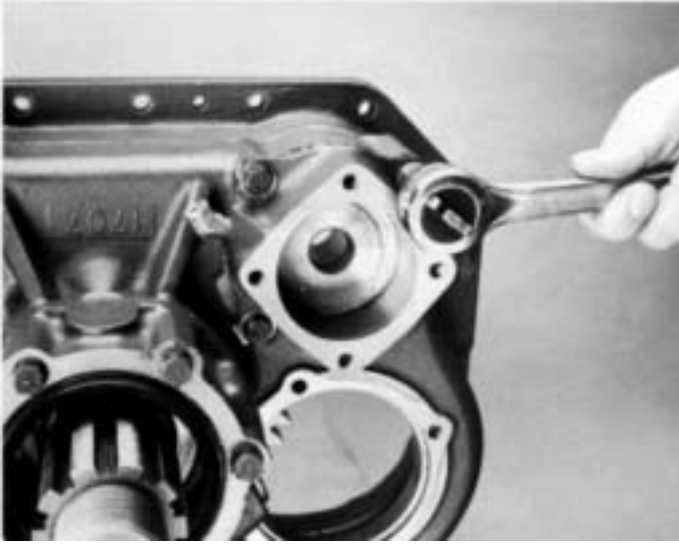

7. Remove capscrews and range cylinder housing.

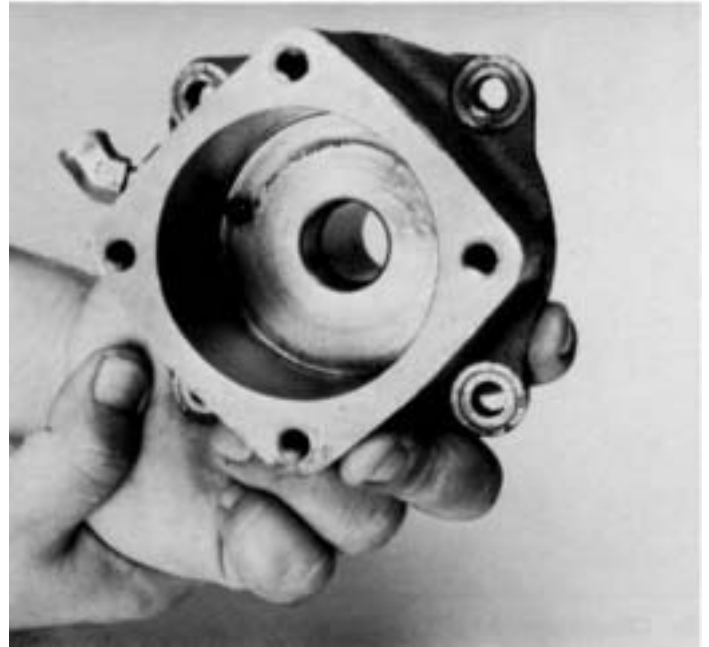

8. If necessary, remove the small O-ring from the range cylinder housing bore.

# DISASSEMBLY-AUXILIARY SECTION

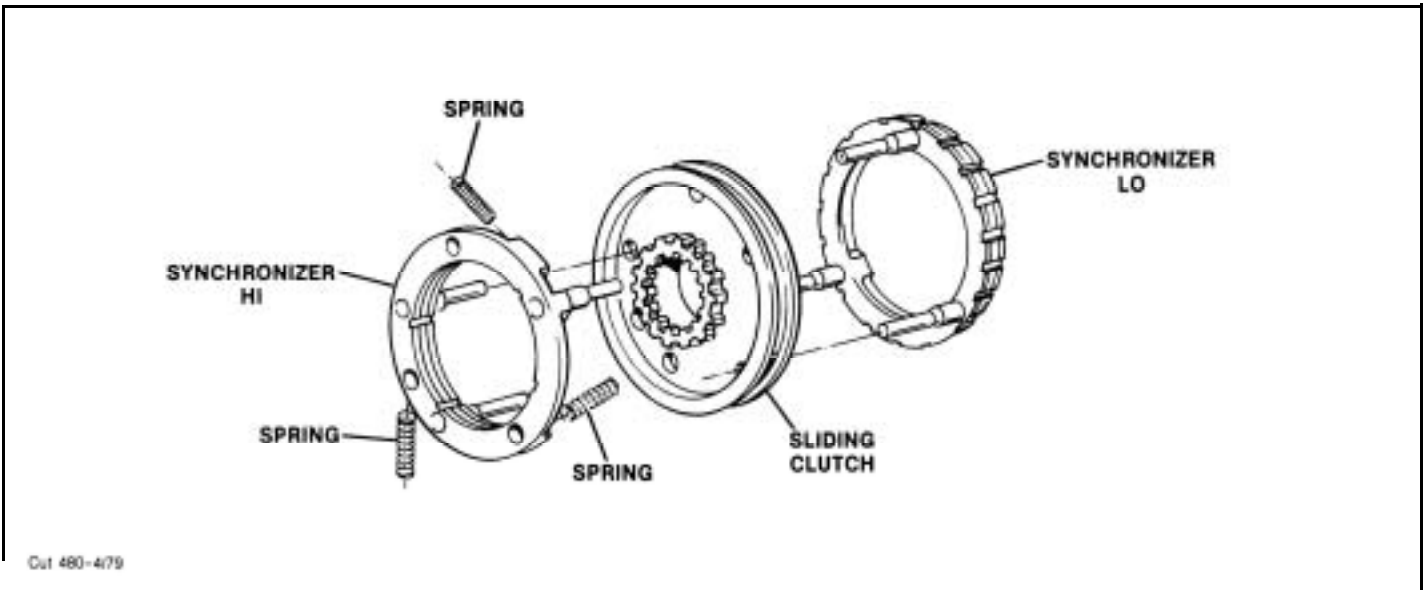

## E. Disassembly Synchronizer Assembly

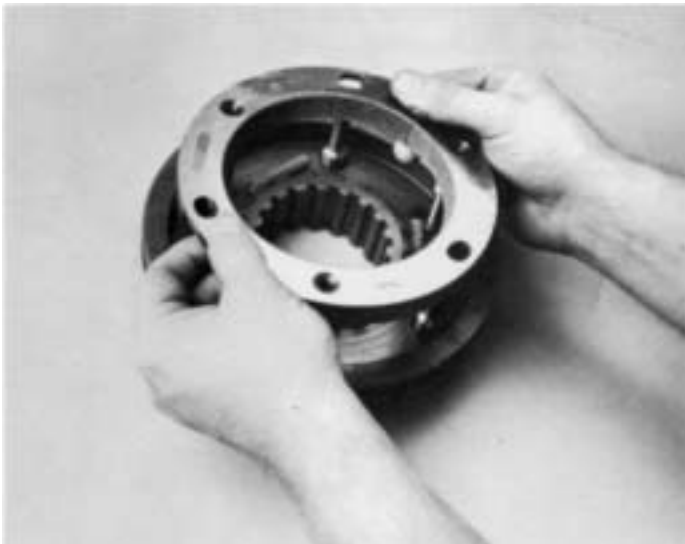

1. Place the larger LO range synchronizer ring on the bench. Cover the assembly with a shop rag to prevent losing the three springs released from the high range synchronizer at the pin locations. Pull the HI range synchronizer from the blocker pins.

2. Remove the sliding clutch from the synchronizer ring LO range pins.



# DISASSEMBLY-AUXILIARY SECTION

## F. Removal and Disassembly Output Shaft and Rear Bearing Assemblies.



1. Use a soft bar and maul to drive the output shaft forward and through the rear bearing assembly.



2. Remove the bearing inner spacer from the output shaft.



3. Use the front face of the reduction gear as a base, press the output shaft through the bearing and gear. This frees the bearing, LO range gear, and the splined washer.



4. Remove the stepped washer, LO range gear, and splined washer from the shaft.

# DISASSEMBLY - AUXILIARY SECTION

---

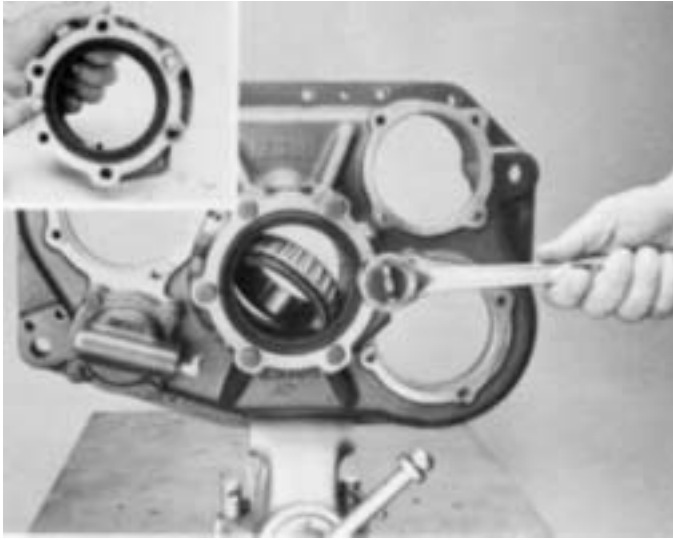

5. Remove the rear bearing retaining cap screws, rear bearing cover, and gasket from the auxiliary housing. The rear bearing cone drops from the housing bore when the cover is removed. If necessary, remove the oil seal from the cover (inset).



6. Remove the two bearing cups and spacer from the bearing bore.

## G. Removal Splitter Cover

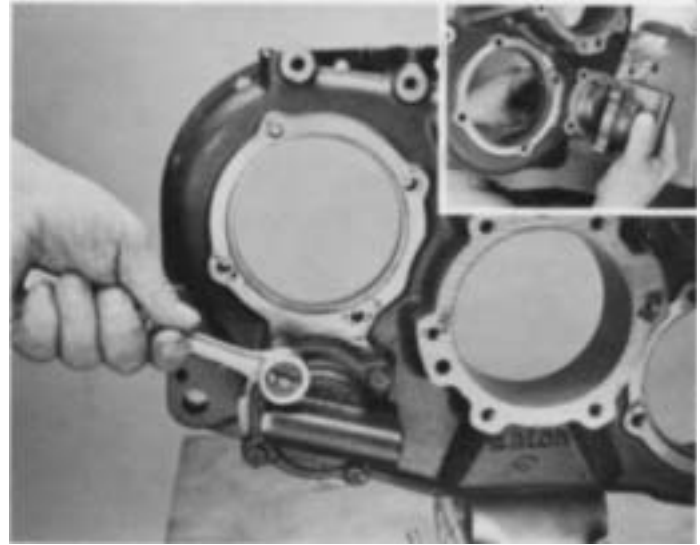

1. Remove the cap screws from the splitter cylinder cover and remove the splitter cylinder cover and gasket from the auxiliary section case.

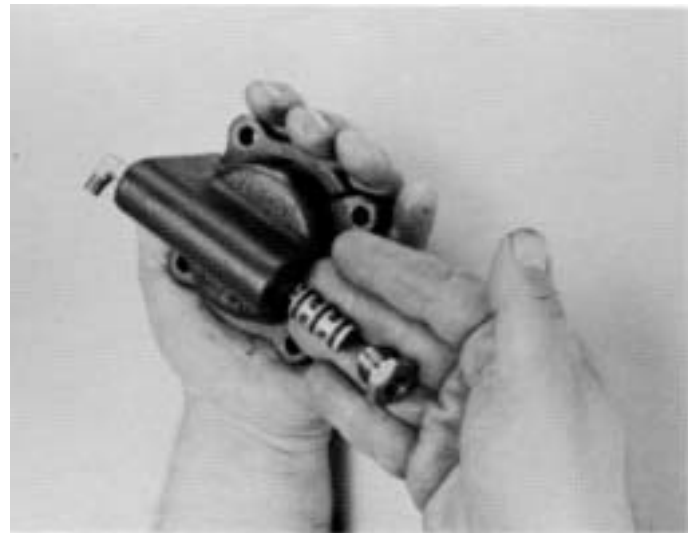

2. If necessary, turn out the insert valve retaining nut and remove insert valve from bore.

# DISASSEMBLY - AUXILIARY SECTION

---



3. Pull the yoke bar from cylinder housing. If necessary, remove the O-ring from piston O.D. (inset).

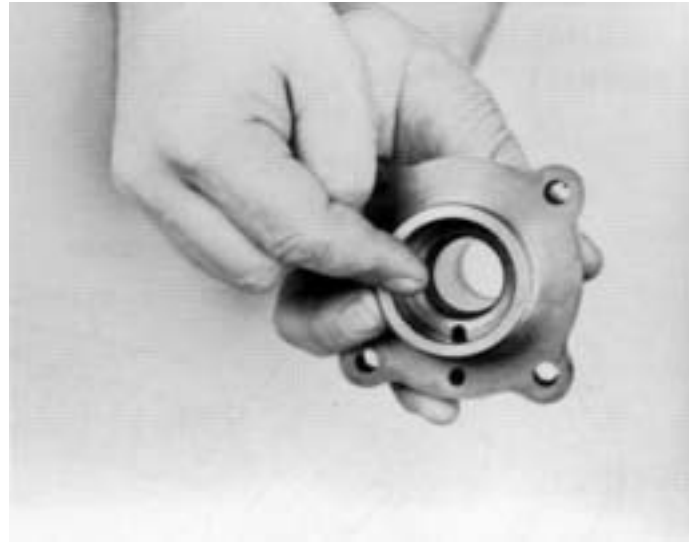

4. If necessary, remove the small O-ring from the cylinder housing bore.

# REASSEMBLY-AUXILIARY SECTION

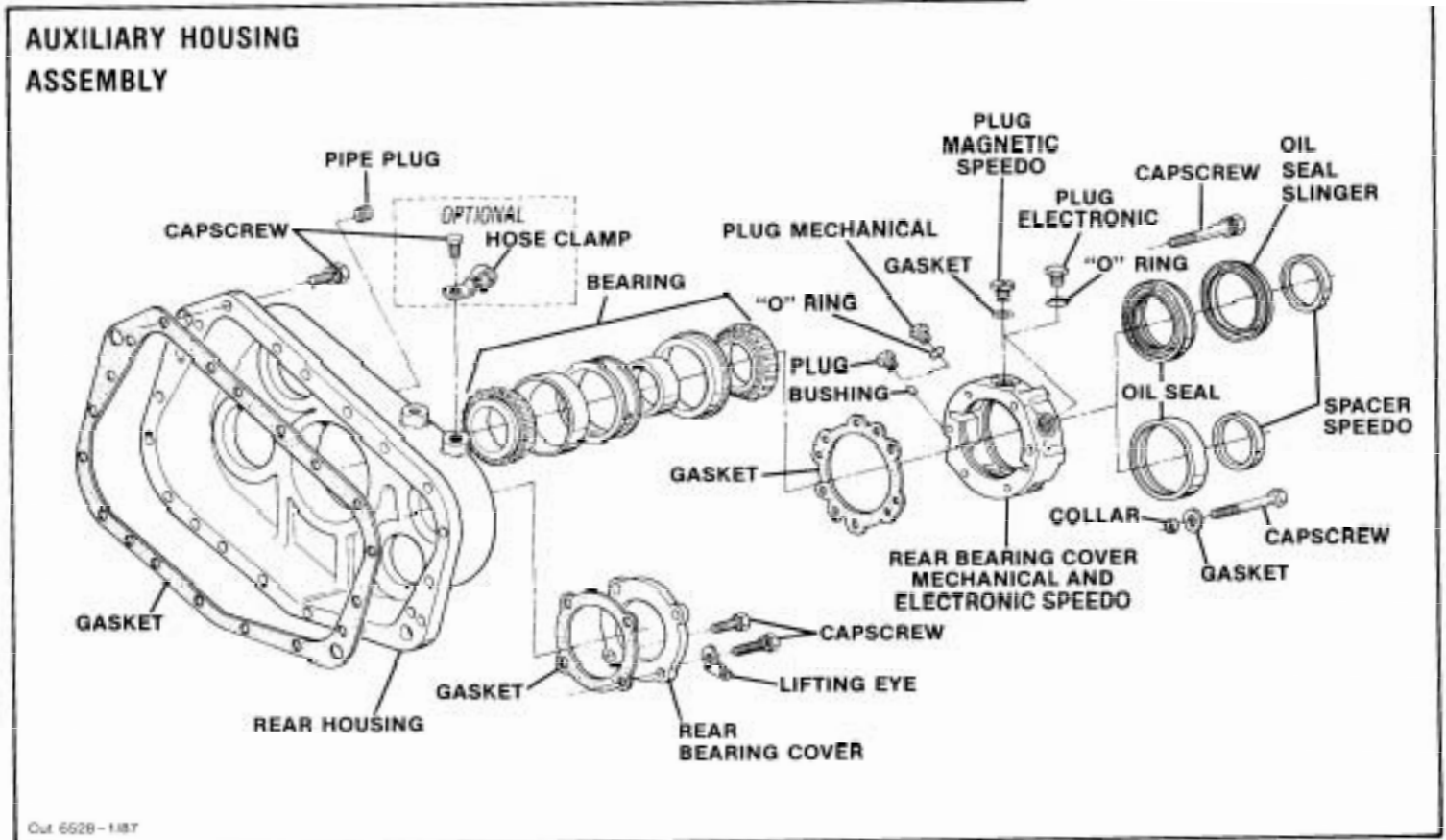

## A. Reassembly and Installation of

**NOTE:** Make sure magnetic plugs preinstalled in auxiliary housing.

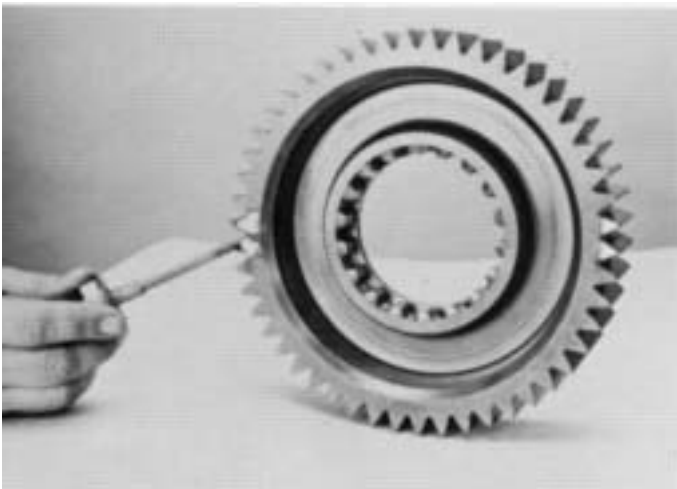

1. **IMPORTANT:** Mark timing teeth on the LO Range gear. A highly visible color of toolmaker's dye is recommended.
  - a. Mark any two adjacent gear teeth on LO Range gear, front side.
  - b. Then mark the two adjacent teeth which are directly opposite the first set marked. There should be the same number of teeth between the markings on each side of the gear.



2. Placed splined washer on output shaft shoulder facing up as shown.

# REASSEMBLY-AUXILIARY SECTION

---



3. Install the LO Range gear on the output shaft, clutching teeth engaged with the splines down to engage the washer splines.



5. Using a heat lamp or hot plate and oil heat the output shaft rear bearing and install on output shaft. Seat the bearing securely on shaft. Bearing can also be installed using the appropriate driver.

**NOTE:** DO NOT HEAT BEARING ABOVE 275°F (136°C).



4. Install the LO Range gear rear washer on output shaft and against gear, with chamfer side facing up.



6. Install the bearing inner spacer on the output shaft.

# **REASSEMBLY - AUXILIARY SECTION**



7. Place the auxiliary housing on a flat bench and install the 2 bearing cups and spacer in the rear bearing bore, the cup with a lip seats next to the rear of the auxiliary case.



2. Install the three springs in bores in HI range synchronizer ring.

## **B. Reassembly Synchronizer Assembly**



1. Place the larger LO range synchronizer ring face down on bench with pins up. Place the sliding clutch, recessed side up, on pins of LO range synchronizer.

**NOTE:** Pins on LO range synchronizer must line up with chamfered holes on bottom of sliding clutch.

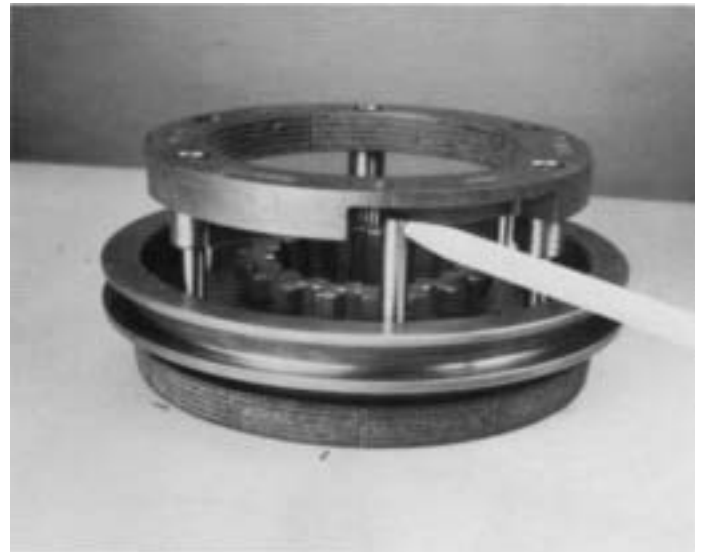

3. Place the HI range synchronizer ring over pins of LO speed synchronizer ring, seating springs against pins.

# REASSEMBLY - AUXILIARY SECTION

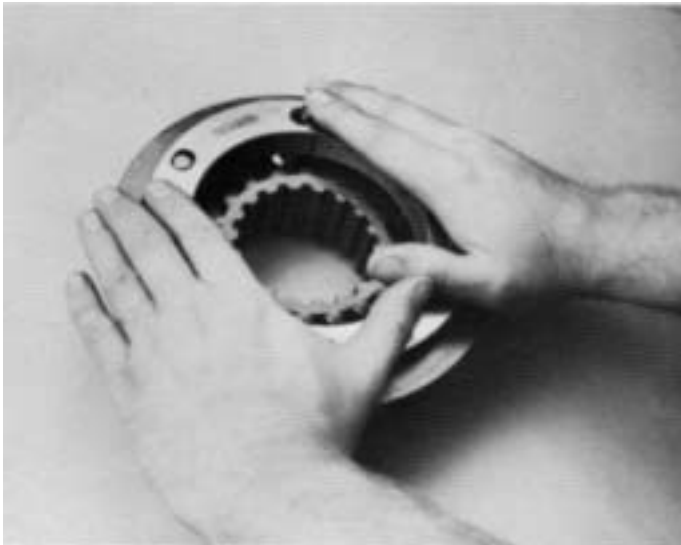

4. Apply downward pressure to the HI range synchronizer ring WHILE TWISTING COUNTER-CLOCKWISE to compress the springs and fully seat ring on blocker pins of LO range synchronizer. It is suggested that a shop towel be placed over the synchronizer to prevent injury to your hands.



5. Install synchronizer assembly to front of output shaft assembly.

## C. Installation of Auxiliary Driver Gear.



1. Place auxiliary drive gear, retainer and 15/16" cap screw on output shaft assembly. Secure cap screw on shaft till tight, recommended torque will be applied during final assembly (pg. 67)

## D. Reassembly of Auxiliary Countershaft Assemblies and Timing.

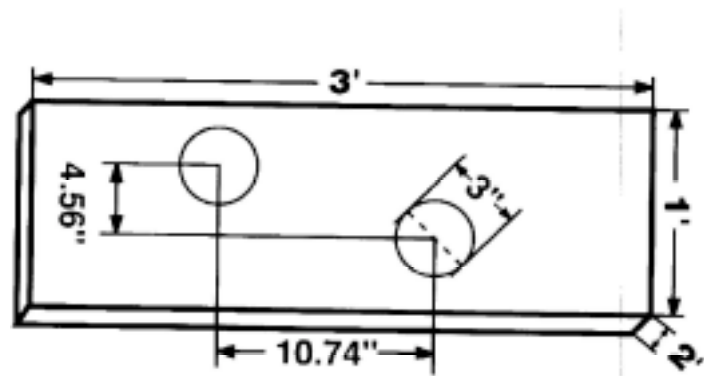

To make reassembly of the auxiliary section easier, you can make this auxiliary section fixture out of a section of 2 x 12.

# REASSEMBLY - AUXILIARY SECTION

---

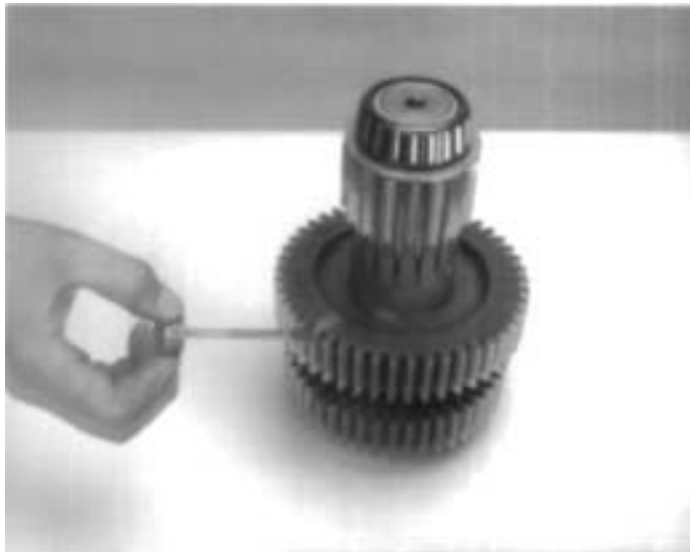

**NOTE:** Auxiliary countershaft bearings will be installed at this time if replacement was required.

1. Mark each countershaft for correct timing. Locate the "O" stamped on the countershaft and mark the tooth with highly visible toolmakers dye or paint.



2. Place the countershaft in fixture or on a flat surface for reassembly. Locate output shaft assembly between countershaft, timing of the auxiliary will be checked at this time. The single marked tooth of each countershaft must align with the two teeth marked on each side of the LO range gear.



3. Install the range yoke into the synchronizer sliding clutch slot, offset side facing down.



4. Place the auxiliary housing over countershaft assemblies and output shaft assemblies.



# REASSEMBLY - AUXILIARY SECTION



5. Heat the rear output shaft bearing cone and install the bearing on the shaft taper side down.

**NOTE:** Do not heat the bearing above 275°F (136°C).

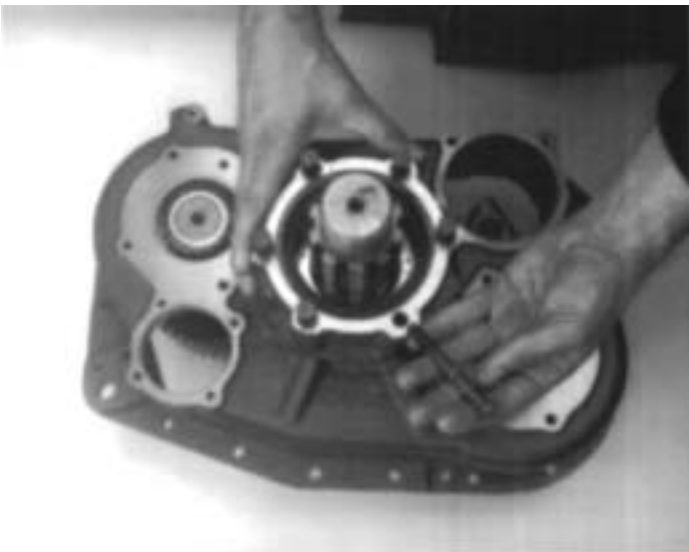

6. Install the rear bearing cover on the auxiliary housing. The nylon collar and brass washer are installed in the chamfered hole on the lower right side of the cover.

**NOTE:** Because the collar becomes distorted when compressed, DO NOT REUSE OLD NYLON COLLAR.

## E. Reassembly Range Cylinder

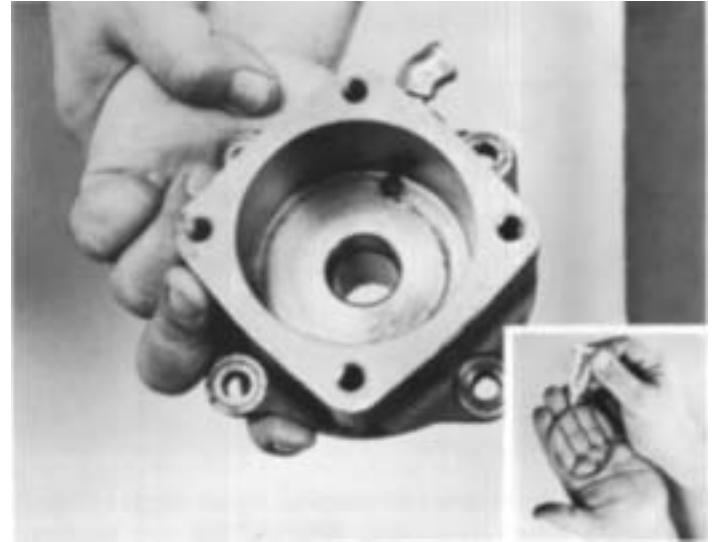

1. Install O-ring in slot of small bore in cylinder. Apply silicone to all O-rings (inset).



2. If previously removed, install the O-rings in the I.D. and O.D. of the range position.

# REASSEMBLY - AUXILIARY SECTION

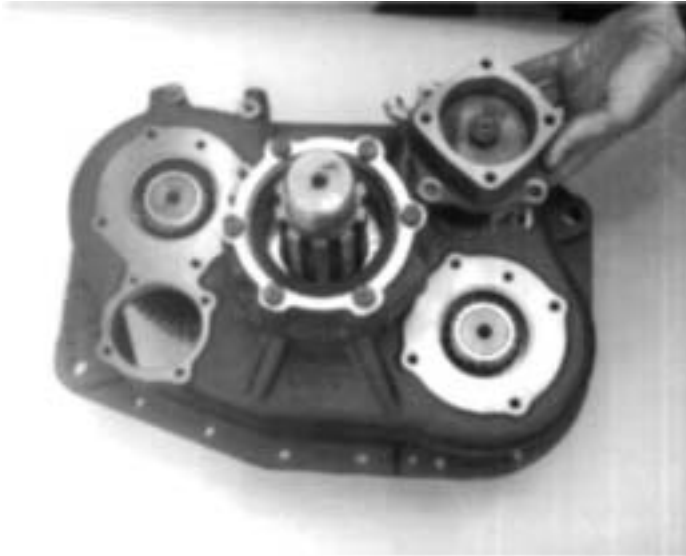

3. Position new gasket on housing. Install range cylinder, piston yoke, piston and retaining nut into housing. Tighten retaining nut to recommended torque. Install 4 capscrews into range cylinder housing and tighten to recommended torque.



4. Place range cylinder cover and new gasket on range cylinder, install 4 capscrews and tighten to recommended torque.

## F. Reassembly and Installation of Splitter Cylinder Assembly

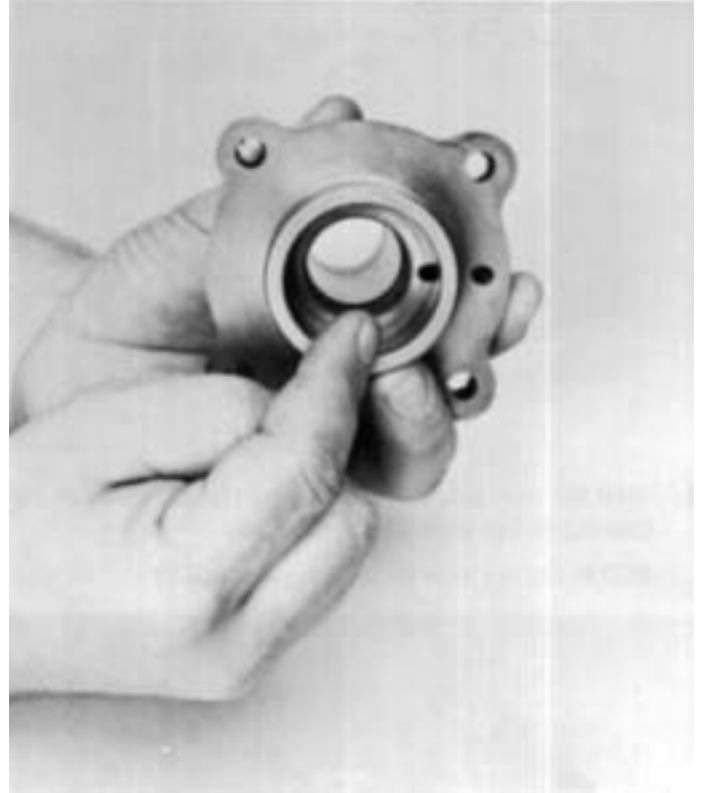

1. If previously removed, install the small O-ring in the cylinder housing bore.



2. If removed, install the O-ring on the piston O.D. (left). Insert the yoke bar in the cylinder housing bore (right).

# REASSEMBLY - AUXILIARY SECTION



3. If previously removed, install the insert valve, flat end the outside, and the valve retaining nut in the bottom bore of the cylinder cover. Tighten to recommended torque ratings.

**NOTE:** Prior to installation of the insert valve, make sure the three O-rings on the valve O.D. are not defective. Replace, if necessary.

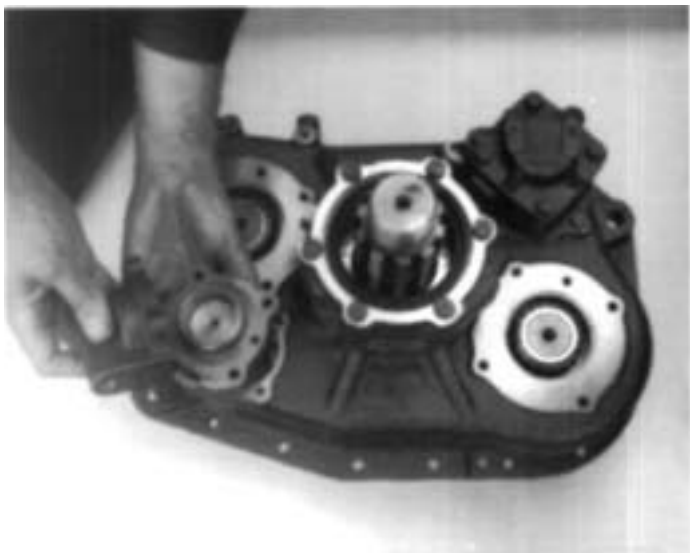

4. Place the new splitter cylinder gasket, splitter cylinder assembly, new splitter cylinder cover gasket and splitter cylinder cover onto the auxiliary housing. Install 4 capscrews into the assembly and tighten to recommended torque.

## G. Reassembly of Auxiliary Rear Bearing Assembly



1. Place the rear bearing cone over the bearing and into the rear bore. Align the .125 shim over the cone and install the rear bearing cover with four (4) capscrews tighten only till snug (right). Retaining straps may also be used at this time they are required for horizontal installation. Complete assembly by installing remaining rear bearing cover (left).

## H. Installation of Range Yoke Capscrews and Recommended Torque of Auxiliary Drive Gear Nut

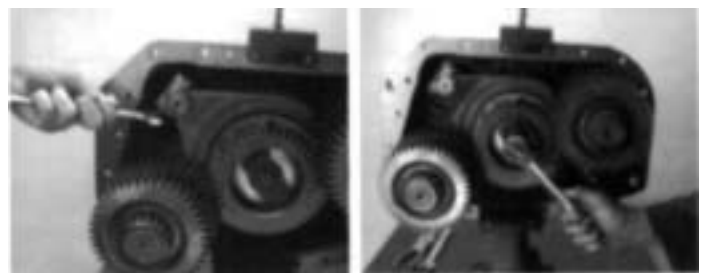

1. Install the 2 capscrews into the range yoke and tighten to recommended torque (right). Tighten auxiliary drive gear retaining nut to recommended torque (left).

# REASSEMBLY - AUXILIARY SECTION

---

## 1. Installation of Splitter Sliding Clutch and Yoke



1. Place splitter shift yoke into splitter sliding clutch slot. Install assembly onto auxiliary section engaging the sliding clutch teeth into the auxiliary drive gear clutching teeth and splitter yoke onto yoke bar align lockscrew tighten to recommended torque and lockwire.

# DISASSEMBLY - FRONT SECTION

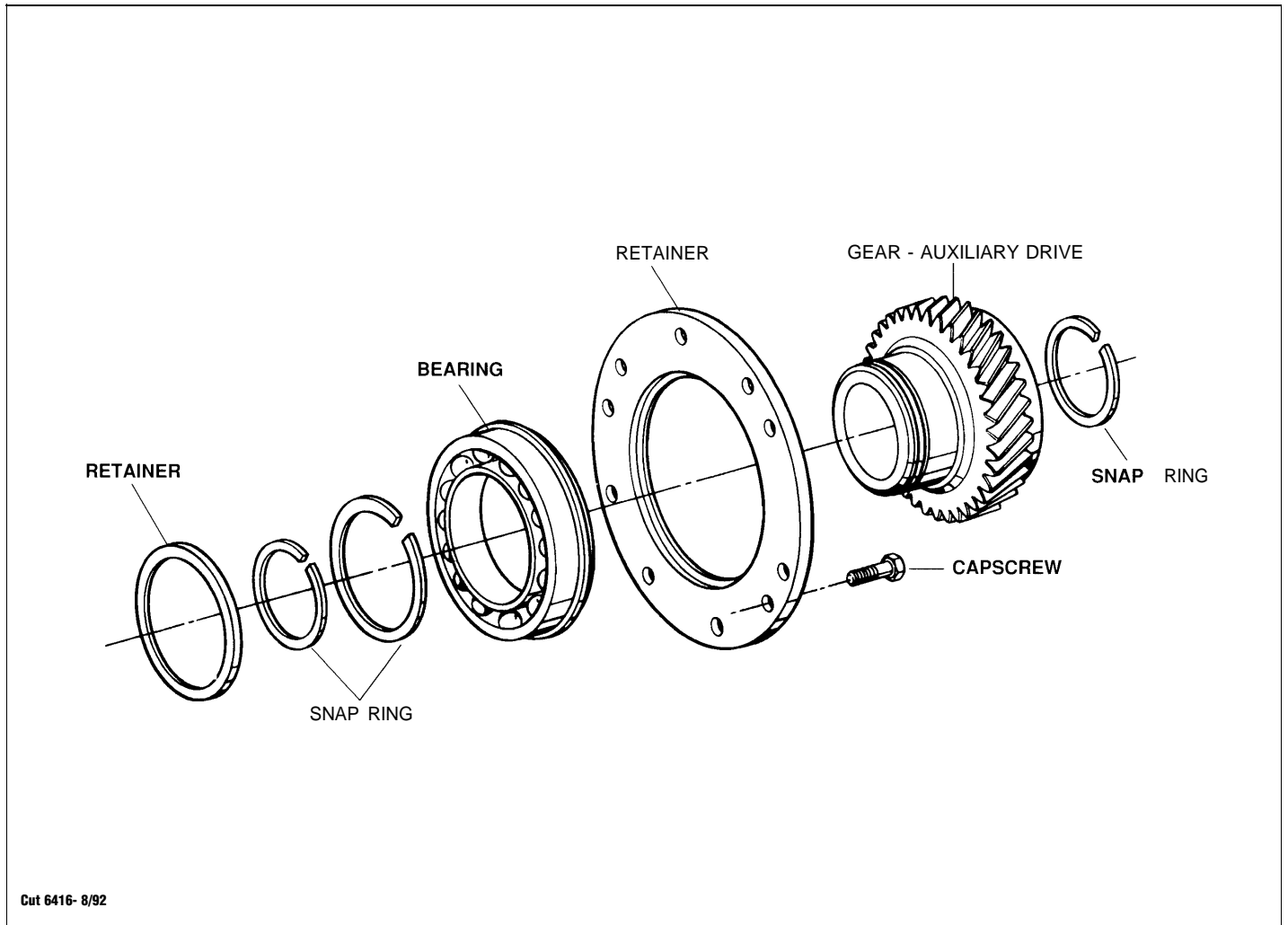

## A. Removal Front Auxiliary Drive Gear

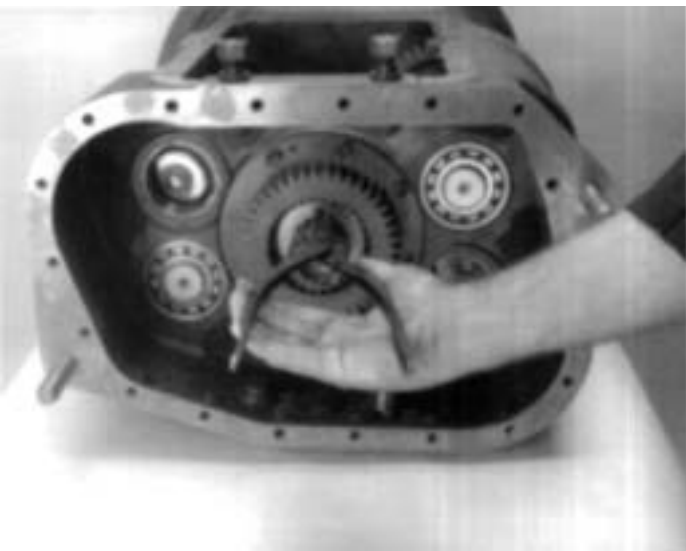

1. Remove snap ring from mainshaft rear groove.

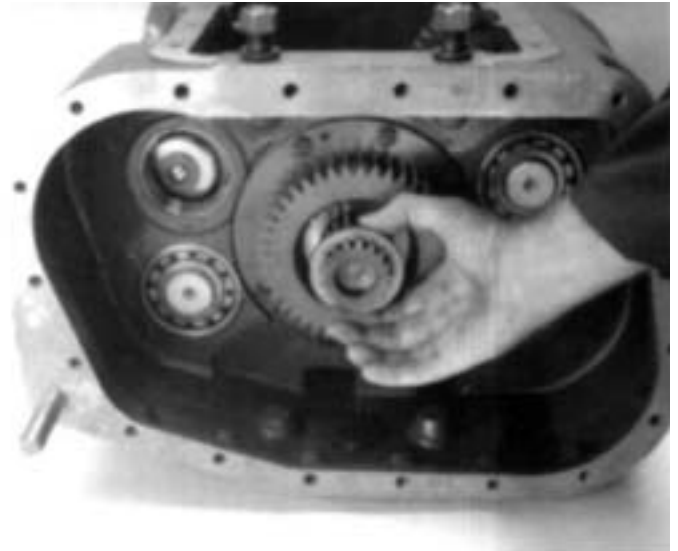

2. Remove the splined washer from inside front auxiliary drive gear assembly.

# DISASSEMBLY - FRONT SECTION

---

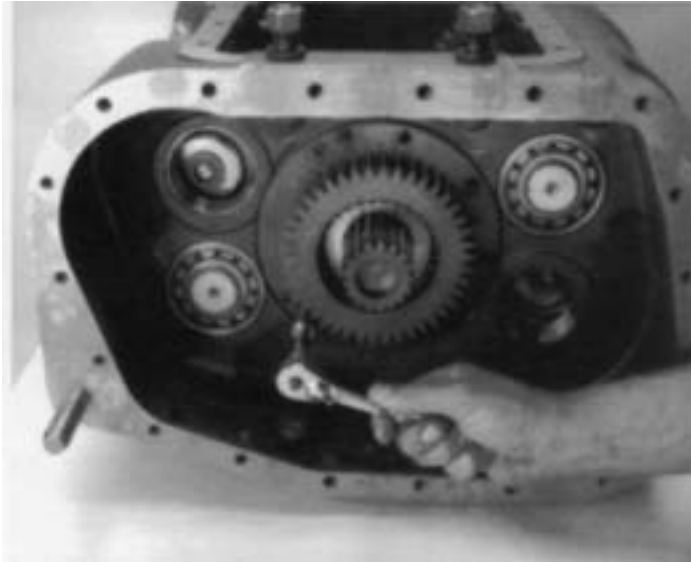

3. Remove six capscrews from the auxiliary bearing retainer ring. Insert three puller screws in the specially tapped holes of retainer ring. Tighten screws evenly to pull the front auxiliary drive gear assembly from case bore.

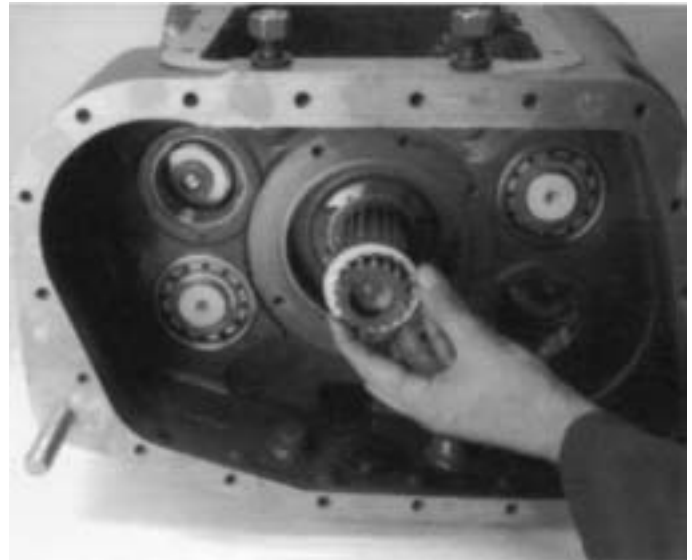

5. Remove the spline d washer from the mainshaft also remove the front auxiliary drive gear retaining snap ring from the mainshaft.

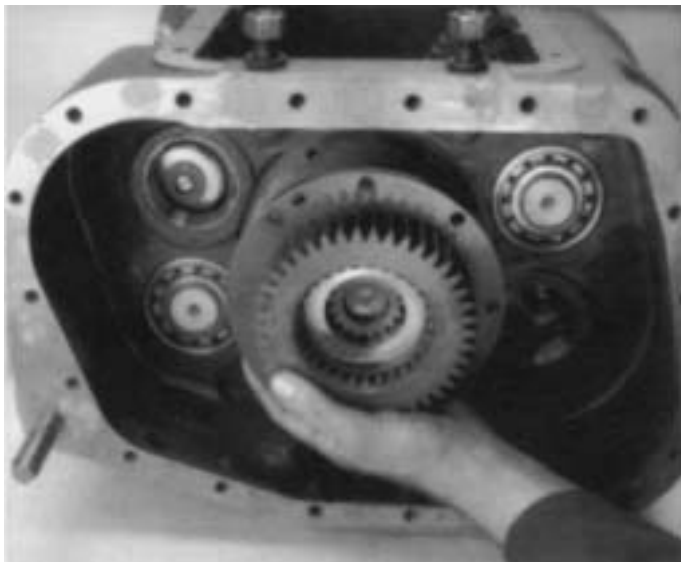

4. Remove front auxiliary drive gear from mainshaft.

# DISASSEMBLY-FRONT SECTION

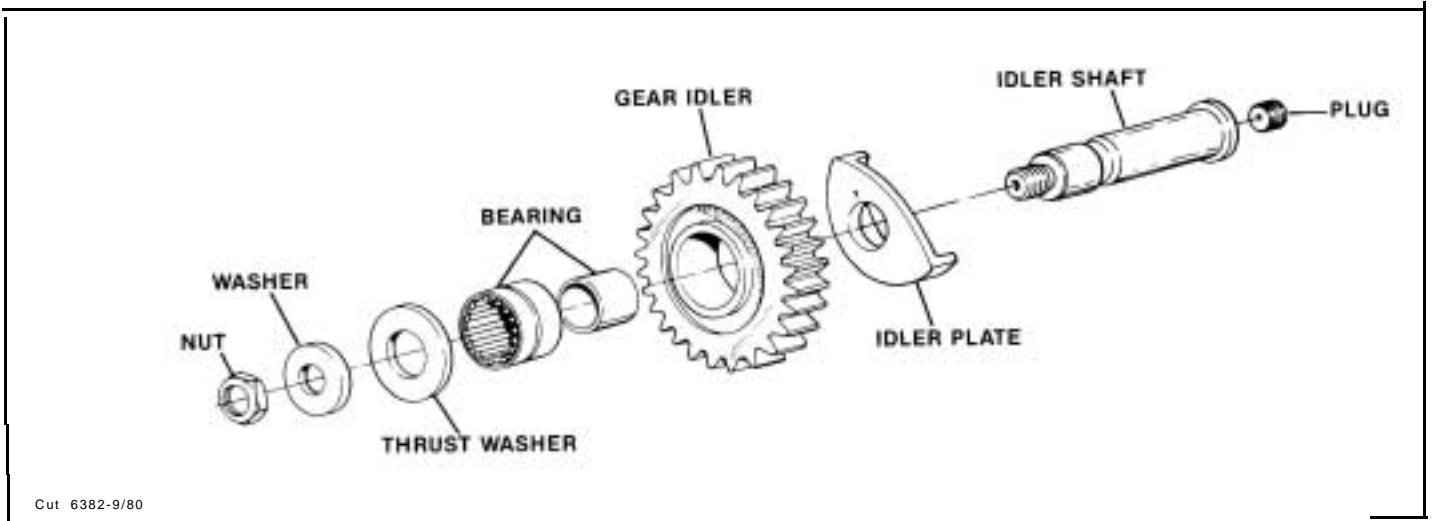

## B. Removal and Disassembly of Left Reverse Idler Gear Assembly



1. Move the mainshaft reverse gear as far to the rear as possible and remove the snap ring from I.D. of gear.

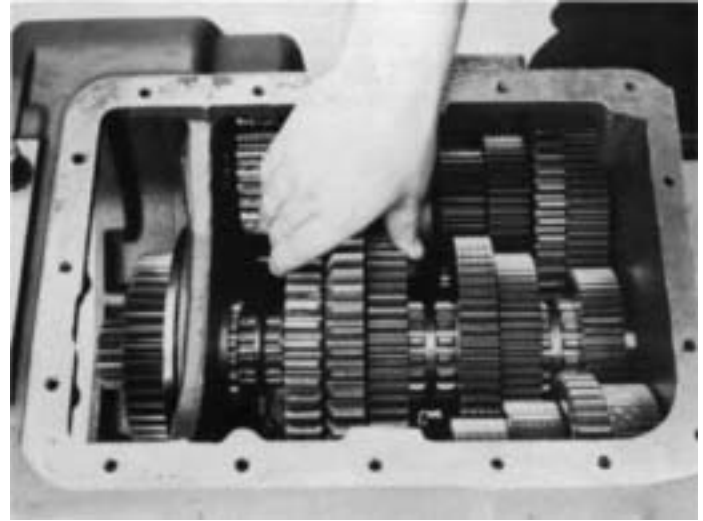

2. Move the reverse gear forward and against the LO speed gear, engaging the splines of mainshaft sliding clutch.

# DISASSEMBLY - FRONT SECTION

---

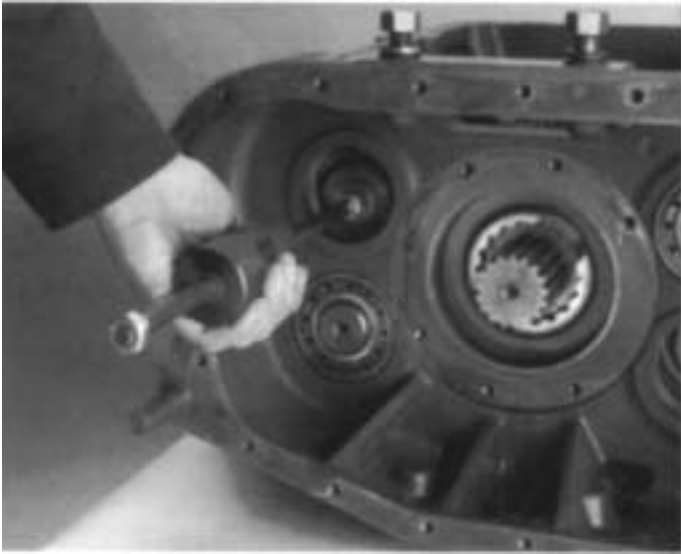

3. Using inside jaw pullers or impact puller, remove the auxiliary countershaft front bearing race from left reverse idler gear bore. If necessary, repeat the procedure for removing the auxiliary countershaft front bearing race from right reverse idler gear bore.

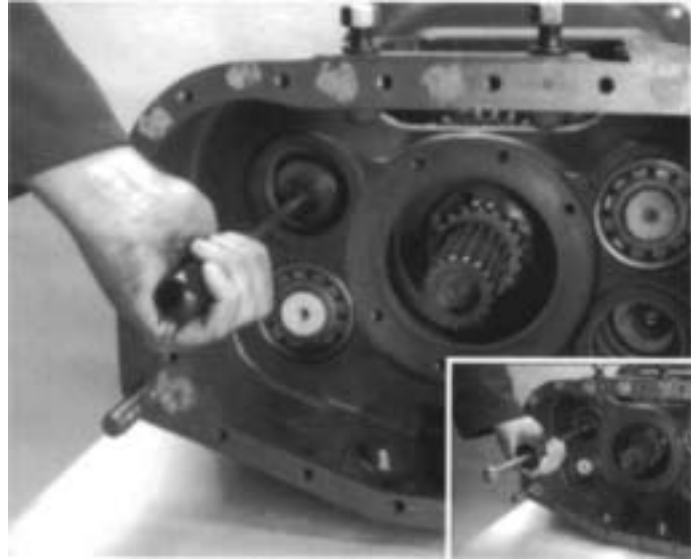

5. Remove the pipe plug from rear of idler shaft and use an impact puller, 1/2"-13 threaded end, to remove shaft from case bore (inset).

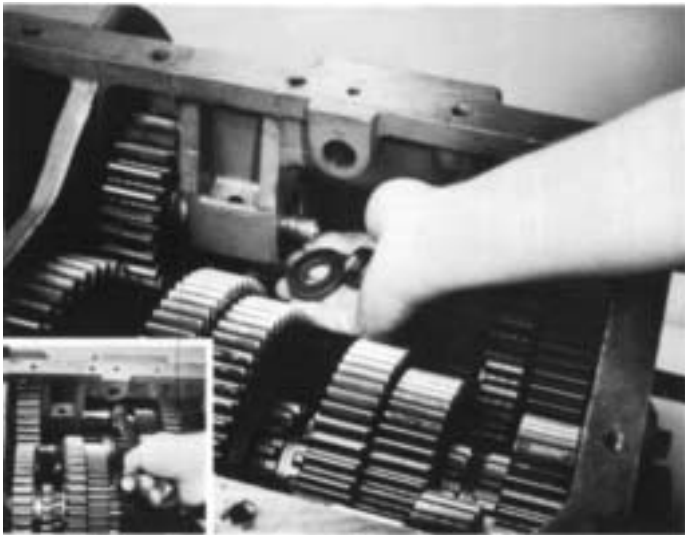

4. Loosen the nut on the idler shaft, (inset). Remove the stop nut and washer from front of idler shaft.

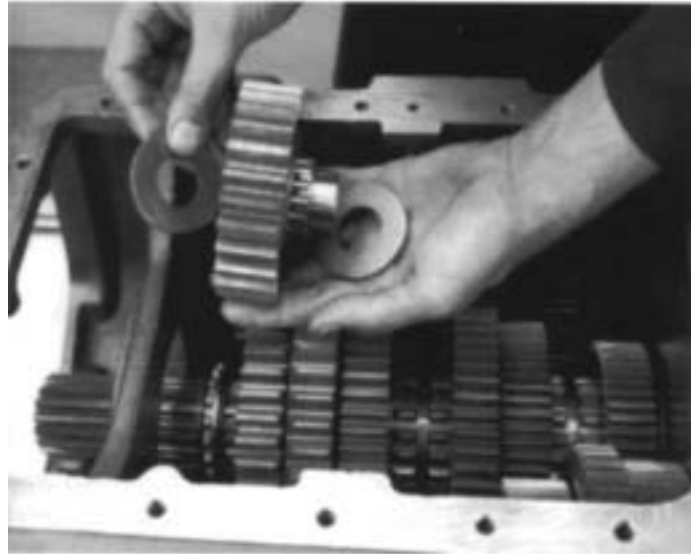

6. As the idler shaft and idler plate are moved to the rear, remove the thrust washer, and gear from case. If necessary, remove the inner race from bearing and remove needle bearing from idler gear.



# DISASSEMBLY-FRONT SECTION

## C. Removal of Countershaft Bearings

**NOTE:** In the following instructions, the front and rear bearings from BOTH countershafts are removed. For removal of the mainshaft assembly from case, it is necessary to remove the bearings from right countershaft ONLY.

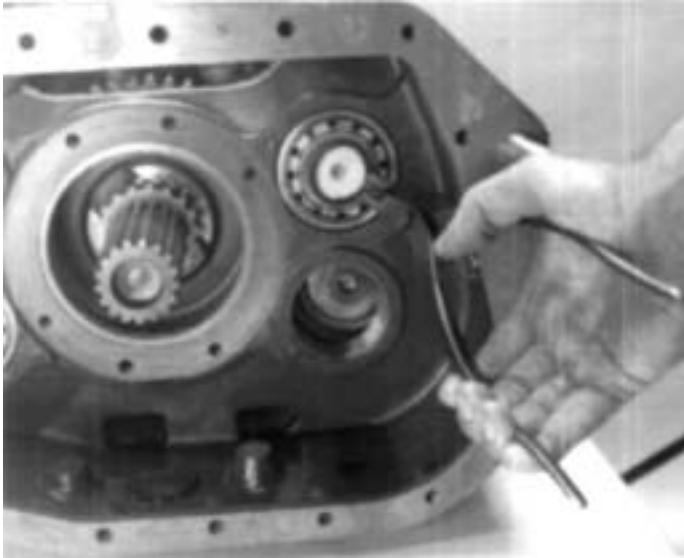

1. Remove snap ring from each countershaft rear groove.



2. From inside the case, use a soft bar and maul to drive the countershaft rear bearings to the rear and from case bores.

**NOTE:** This procedure will damage the bearings and should not be attempted unless replacement of the bearings is planned.

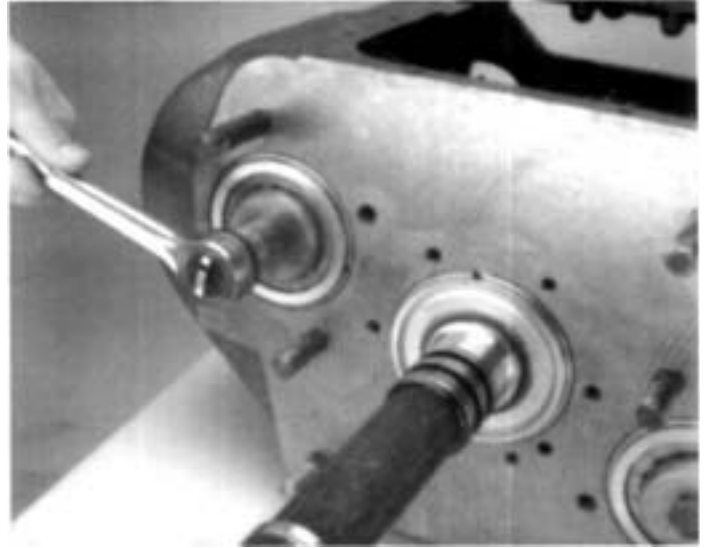

3. Loosen and remove capscrew from retaining plate on upper countershaft front.



4. Use a soft bar and maul to drive each countershaft to the rear as far as possible. This partially unseats the front bearings.

**NOTE:** The soft bar should have a flattened end that is large enough so damage to the countershaft end does not occur.

# DISASSEMBLY - FRONT SECTION

---

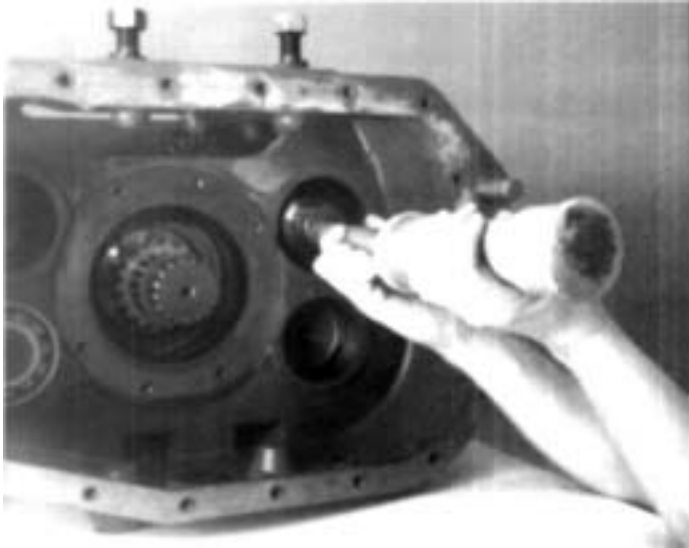

5. From the rear of the countershaft drive the shaft forward to unseat the front bearing from the front case bore to expose the bearing snap ring.



6. Use a bearing puller or pry bars to remove the countershaft front bearings.

**NOTE:** The front roller bearing inner race will remain pressed on the front countershaft.

# DISASSEMBLY-FRONT SECTION

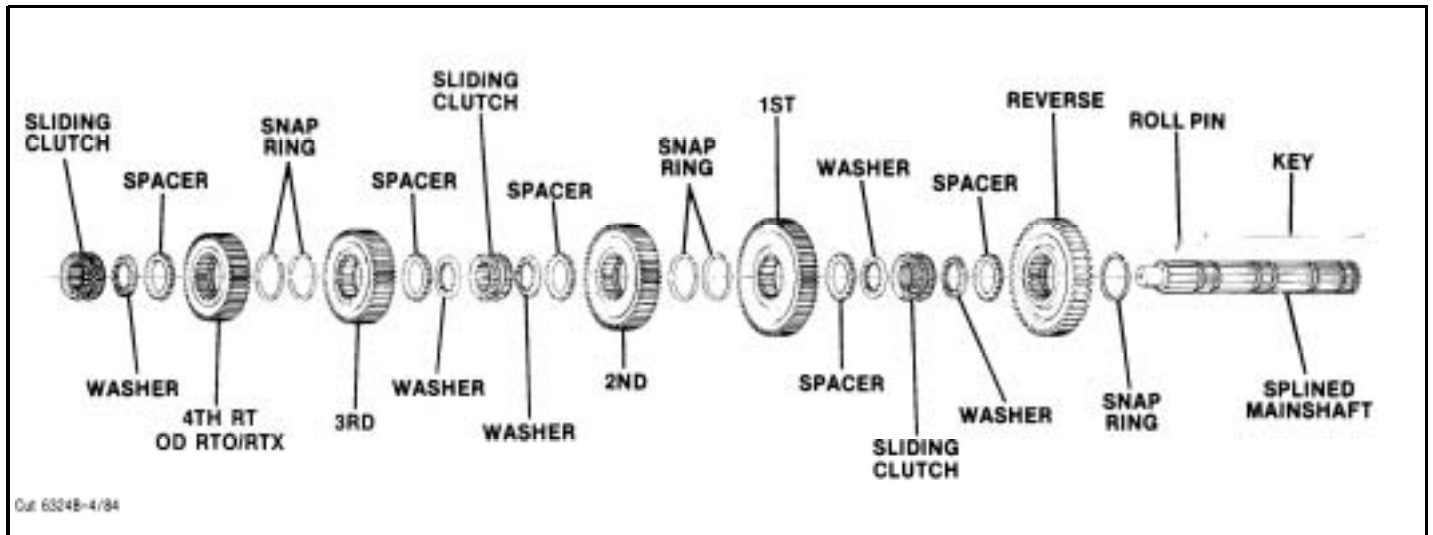

## D. Removal and Disassembly of Mainshaft Assembly

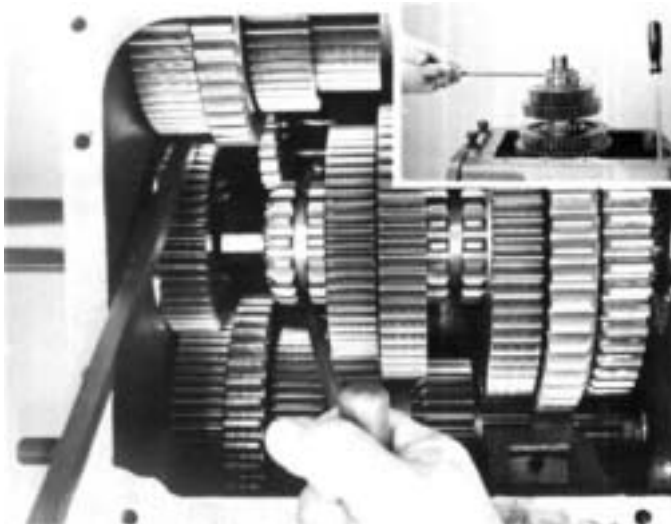

1. Block the right countershaft assembly against case wall and pull the mainshaft assembly to the rear to free pilot from input shaft pocket. Tilt front of mainshaft up and lift the assembly from case (inset). Use caution as the reverse gear is free and can fall from shaft.

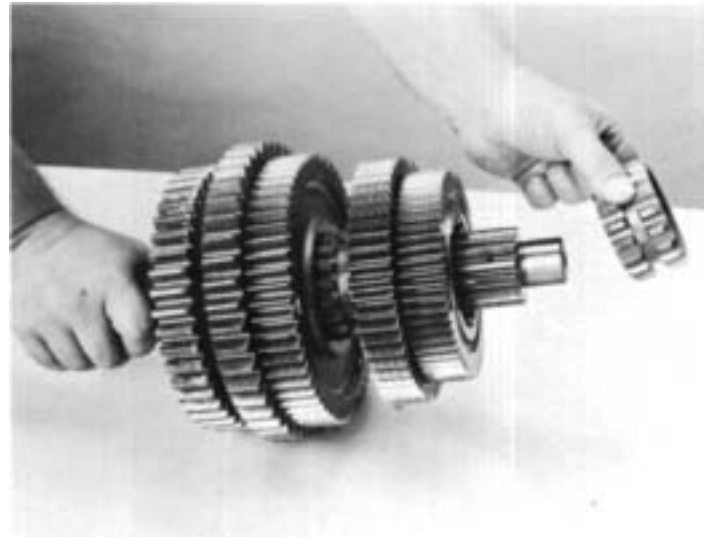

2. Remove the 3rd-4th speed sliding clutch from mainshaft front.

# DISASSEMBLY-FRONT SECTION

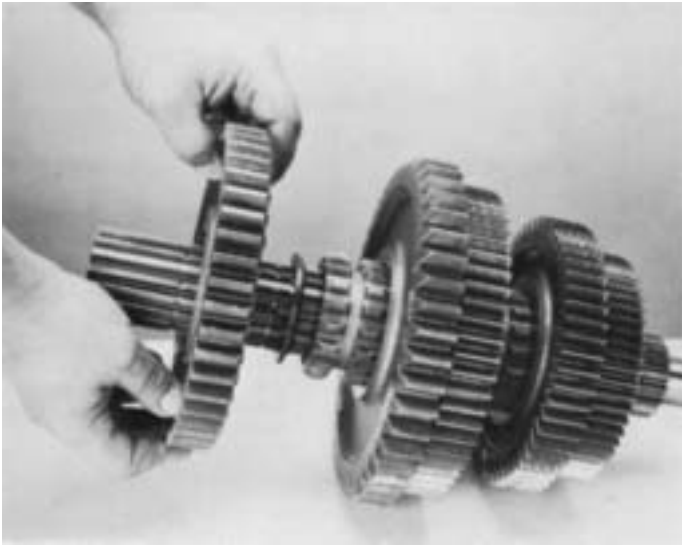

3. Remove the reverse gear and spacer from mainshaft rear.

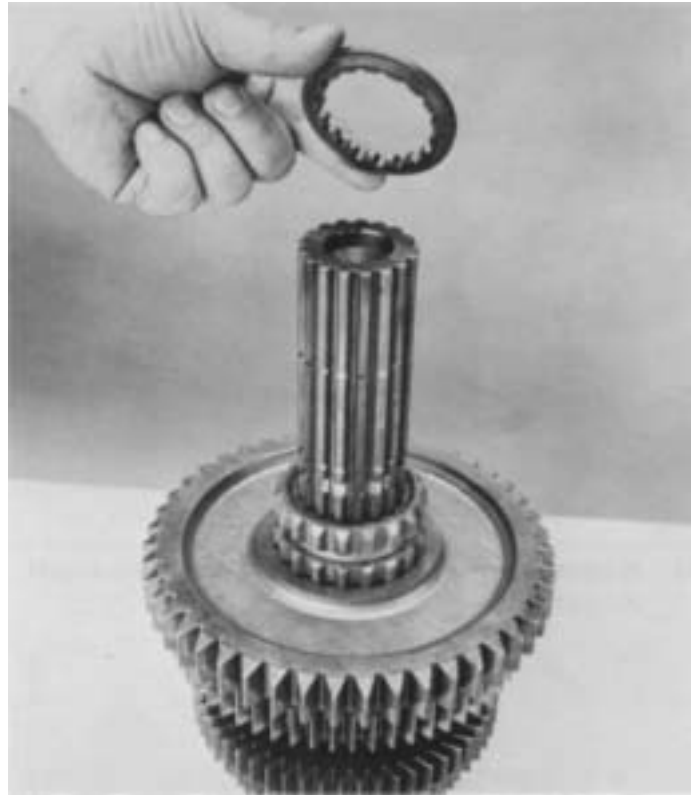

5. Turn the reverse gear limit washer to align its splines with those of the mainshaft and remove washer.

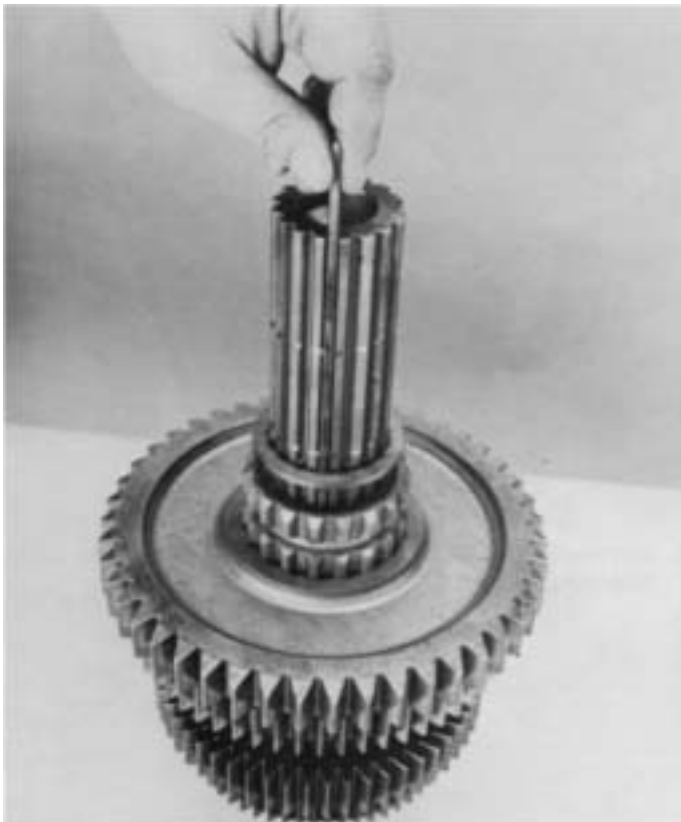

4. From mainshaft rear, pull the key from mainshaft key way.

**NOTE:** When removing limit washers, spacers and gears, note their location on mainshaft to facilitate reassembly. Keep the internal-splined washers and external-splined spacers with the gear from which they were removed. There is **ONLY** one limit washer and one spacer belonging to each gear.

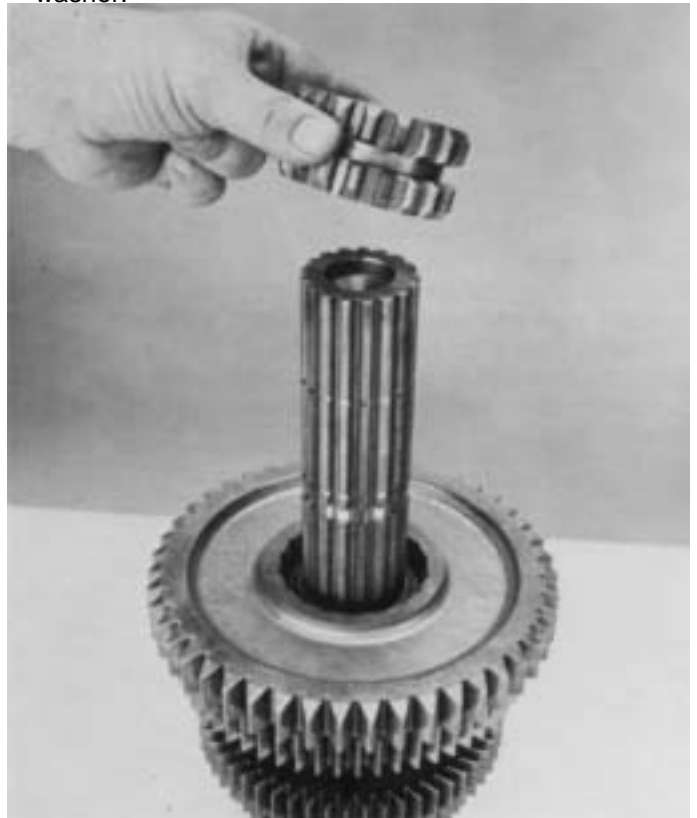

6. Remove the LO-Reverse speed sliding clutch from mainshaft.

# DISASSEMBLY-FRONT SECTION

---

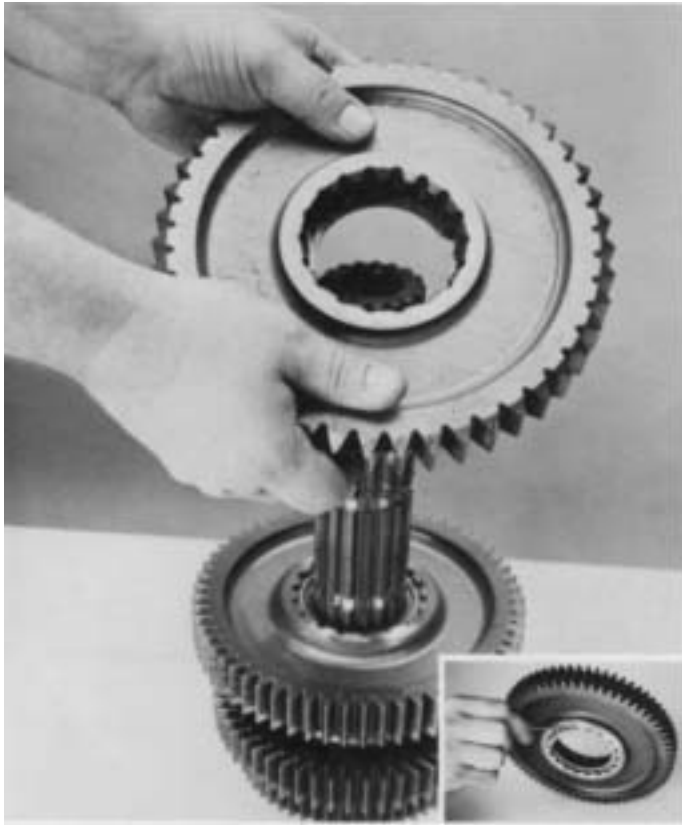

7. Using a small screwdriver, turn the limit washer in hub of LO speed gear to align its splines with those of the mainshaft. Pull the LO speed gear from rear of mainshaft to remove limit washer, spacer, and gear. If necessary, remove the snap ring from I.D. of gear (inset).

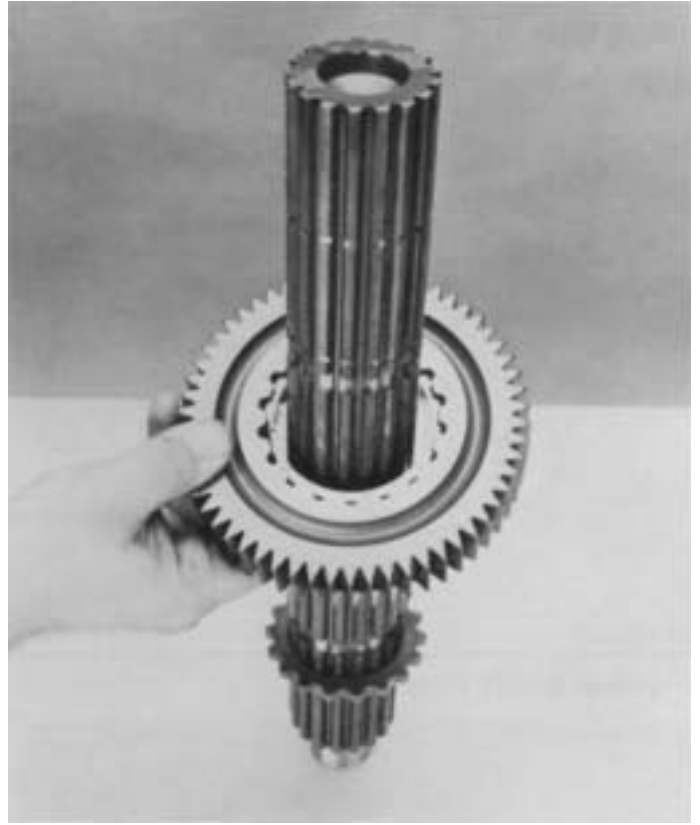

8. Remove each remaining gear, limit washer, spacer, and sliding clutch from mainshaft in the same manner previously detailed. And, if necessary, remove the snap ring from I.D. of each gear.

# DISASSEMBLY - FRONT SECTION

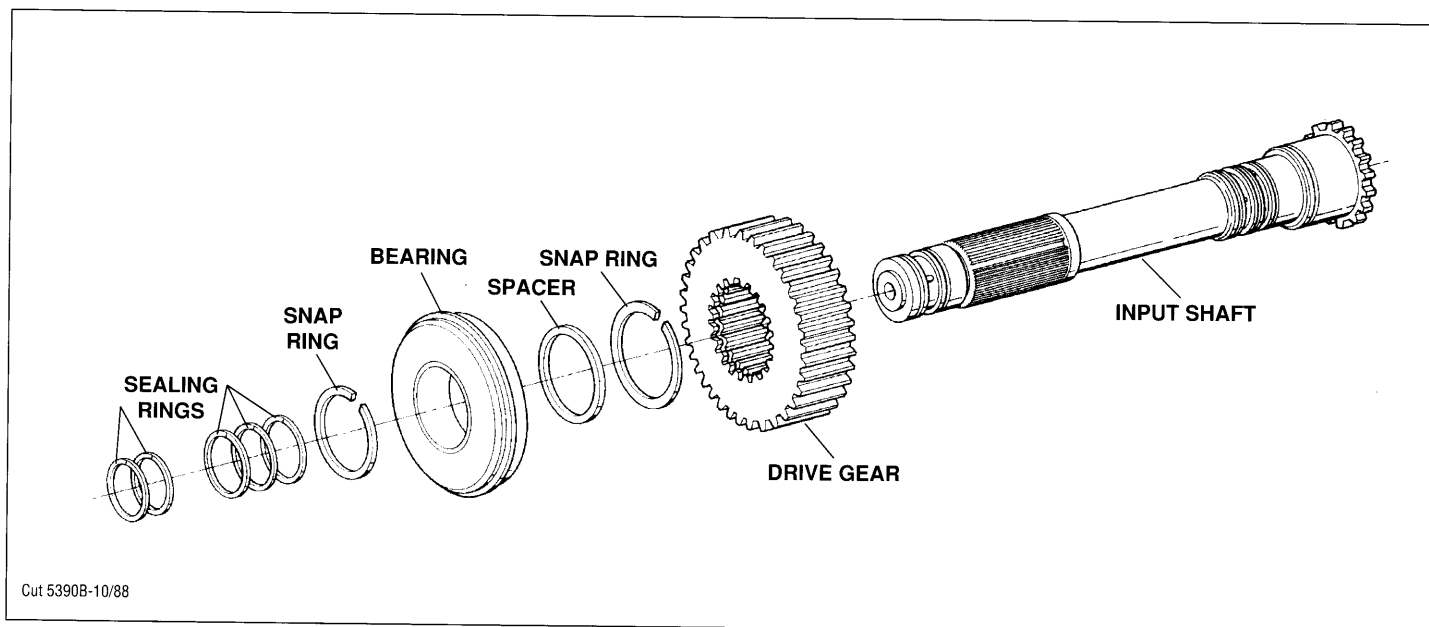

## E. Input Shaft Removal



1. Remove the input bearing snap ring from shaft.

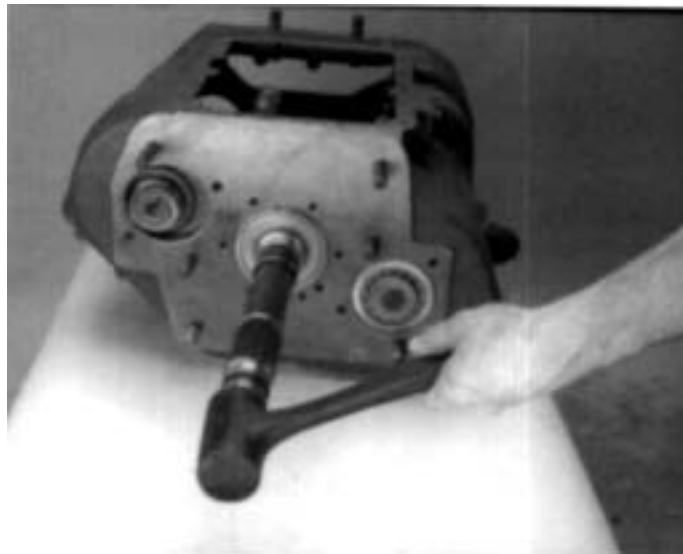

2. Use a soft mallet to drive the input shaft toward the rear of the transmission. Pull the shaft forward and repeat as necessary.

# DISASSEMBLY - FRONT SECTION

---

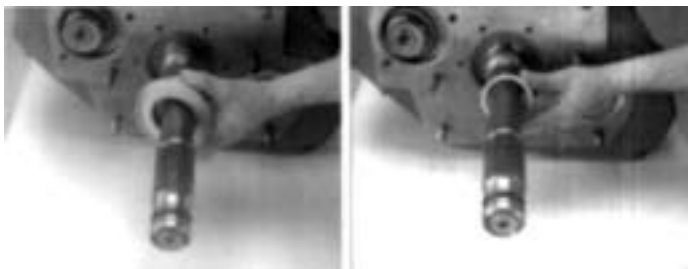

3. Use pry bars to complete the input shaft bearing removal (left). Remove spacer from input shaft (right).

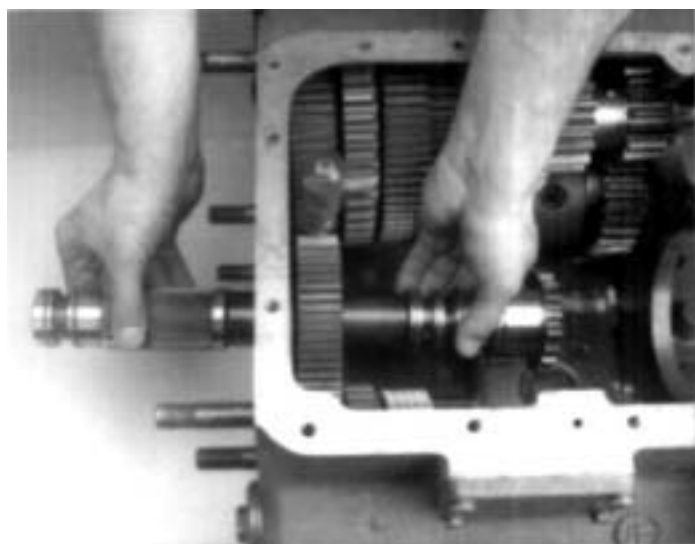

4. Push input shaft through the drive gear and remove the input shaft from case.

**NOTE:** The input shaft is a NON-SERVICABLE assembly excluding the sealing rings and should be replaced if damaged.

**NOTE:** Input shaft can be serviced without removing the main shaft. Remove the snap ring and input shaft bearing remove the internal snap ring from the drive gear and remove the input shaft.



5. Inspect the input shaft bushing for wear and replace if necessary.
6. The main drive gear can be removed from the case this time.

# DISASSEMBLY - FRONT SECTION

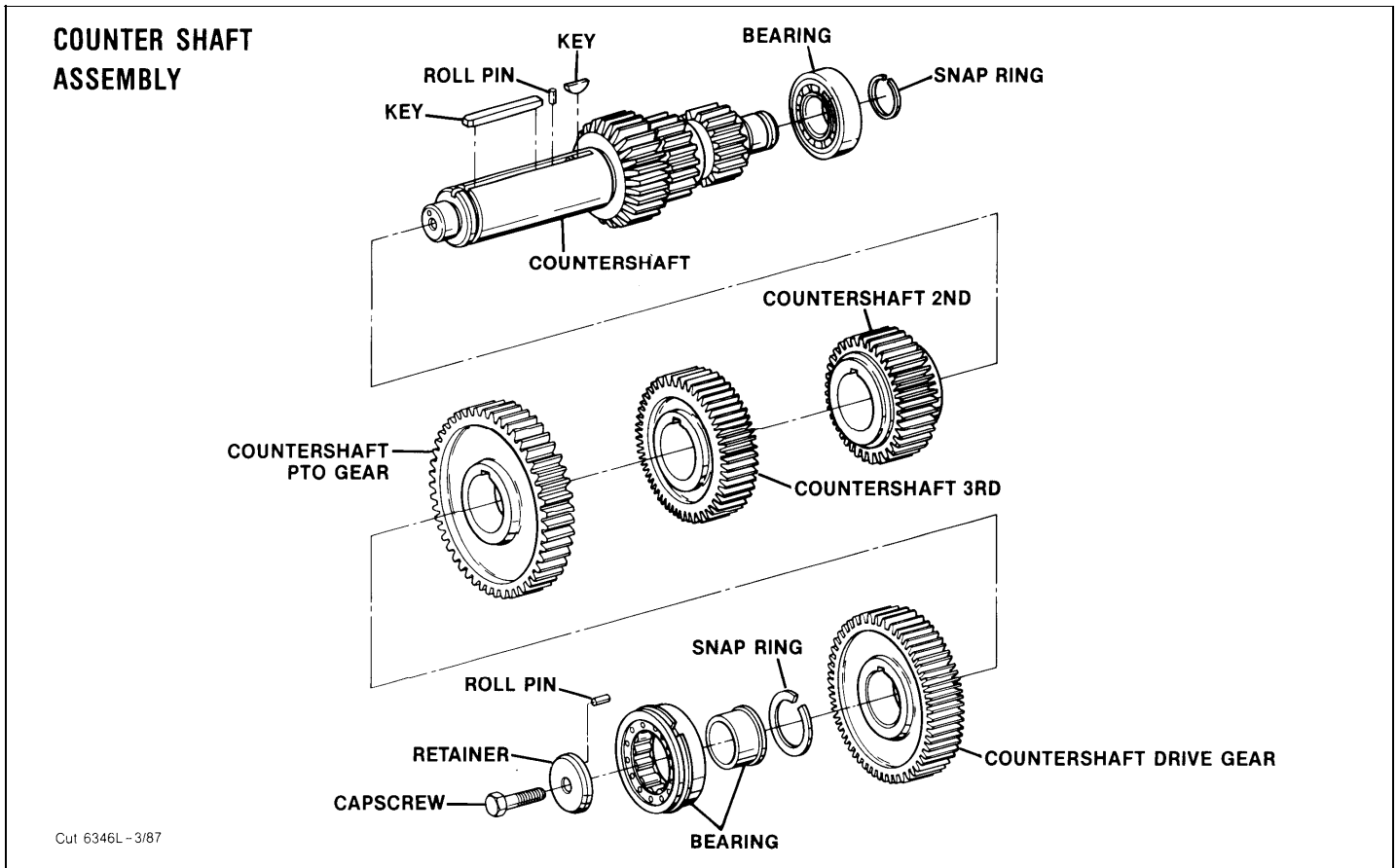

## F. Removal and Disassembly of Countershaft Assemblies

**NOTE:** Except for the PTO gears, the left and right countershaft assemblies are identical and disassembled in the same manner.

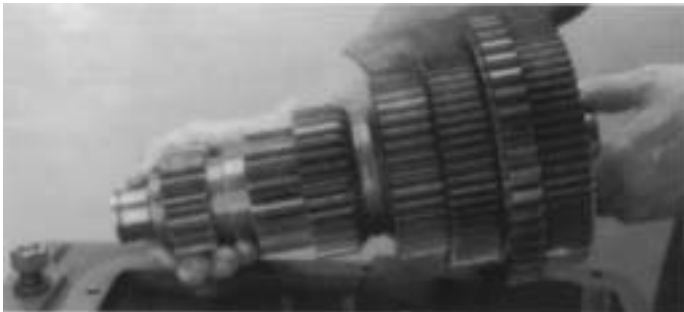

1. Move the right countershaft assembly to the rear as far as possible so front of shaft can be removed from case bore and moved to the center of the case. Lift the assembly from case and repeat the procedure for left countershaft assembly.

**NOTE:** The left and right reverse idler gear assemblies are identical and disassembled in the same manner. If removal and disassembly of this assembly is necessary, refer to Part B of this section.

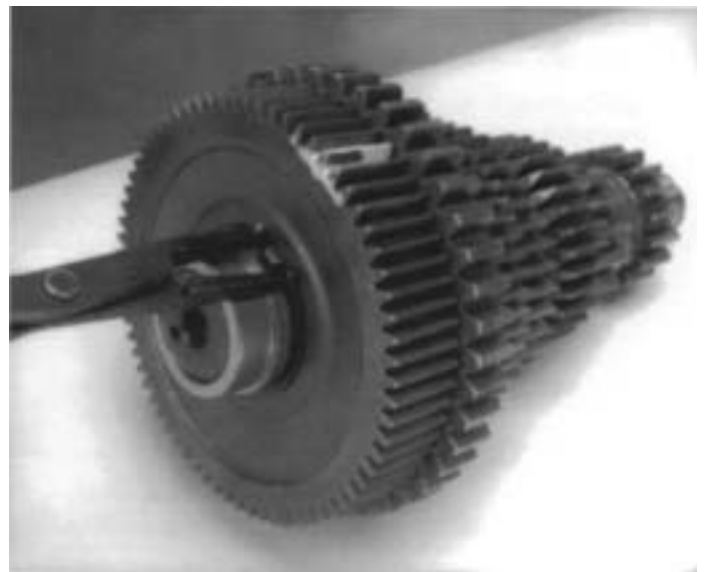

2. Remove the drive gear retaining snap ring from front of each countershaft.



# DISASSEMBLY - FRONT SECTION

---



3. Use the rear face of 3rd speed gear as a base, press the drive gear, PTO gear, and 3rd speed gear from each countershaft. This removes the front bearing inner race from the countershaft.

**IMPORTANT: NEVER USE THE PTO GEAR AS A PRESSING BASE.** The narrow face width of this gear makes it very susceptible to breakage.



4. Disassembly is complete at this point due to the welded countershaft design. Replacement of reverse, low first and 2nd speed gears will be completed as an assembly gears are not available separately.

## **G. Removal and Disassembly of Right Reverse Idler Gear Assembly**

**NOTE:** To remove the right reverse idler gear assembly see section B. The right and left reverse idler gear assemblies are disassembled in the same manner.

# DISASSEMBLY - FRONT SECTION

---

## H. Disassembly Auxiliary Drive Gear Assembly

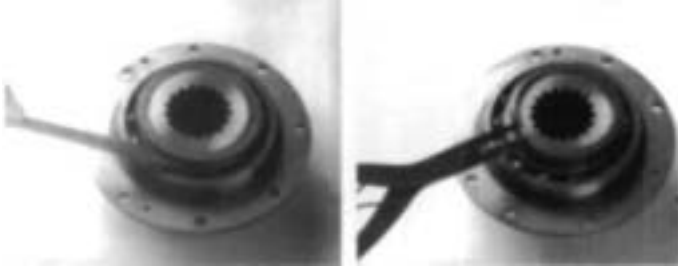

1. Remove the retaining ring from the front of the auxiliary drive gear (left) remove the snap ring from the auxiliary drive gear hub (right).



3. If necessary, remove the O-rings from hub O.D. of front auxiliary drive gear.



2. Using the rear face of retainer ring as a base, Dress the drive gear through bearing.

# REASSEMBLY - FRONT SECTION

## A. Reassembly of Auxiliary Drive Gear Assembly

NOTE: If previously removed, install the O-rings on extended front hub of front auxiliary drive gear.

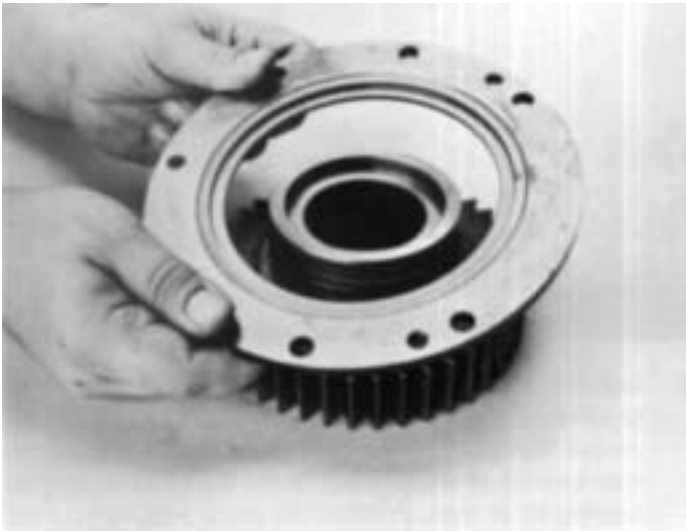

1. Install the retainer ring on front auxiliary drive gear, snap ring groove facing front hub and away from gear teeth.



2. Start the front auxiliary drive gear bearing on front hub, bearing snap ring facing groove in retainer ring. Use both hands, press the bearing on gear with snap ring in groove of retainer ring (inset).

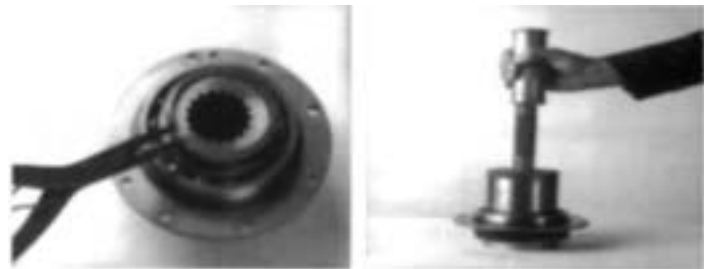

3. Install the snap ring into its groove (left) place the outer retainer ring and seat with the proper driver (right).

# REASSEMBLY - FRONT SECTION

## CASE ASSEMBLIES

**NOTE:** Before starting reassembly, make sure the three magnetic discs are solidly in place at bottom of case. These can be secured to disc mounting surfaces with Scotch Grip Rubber Adhesive or equivalent adhesive.

### C. Reassembly and Installation of Right Reverse Idler Gear Assembly

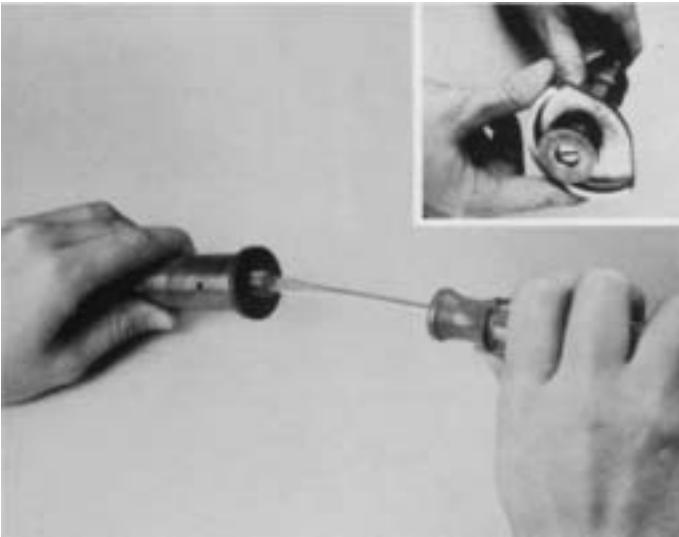

1. If previously removed, thread pipe plug in rear of reverse idler shaft and tighten. Install the thrust washer to the end of the idler shaft.

**NOTE:** If previously removed, replace the needle bearing into bore of reverse idler gear.

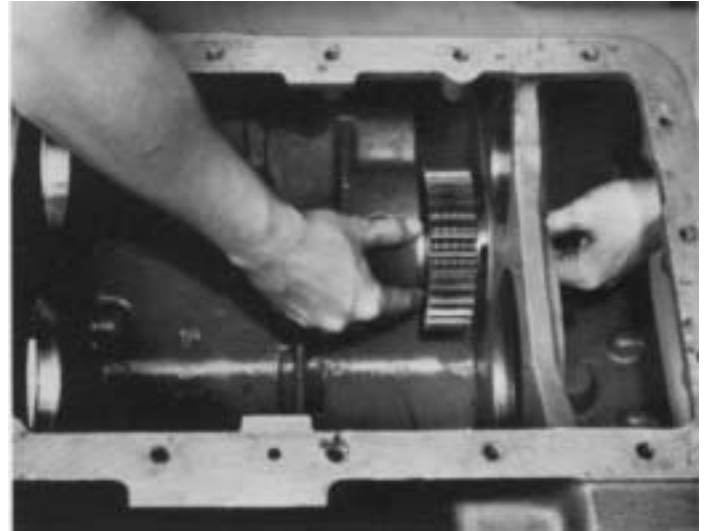

2. Install the bearing inner race on idler shaft and insert shaft into case bore, threaded-end of shaft to the front. As the idler shaft is moved forward, install the reverse idler gear on shaft, long hub to the front and seating on bearing inner race. Position the thrust washer on shaft between the gear and support boss in case and continue with movement of idler shaft forward into bore of Support boss.

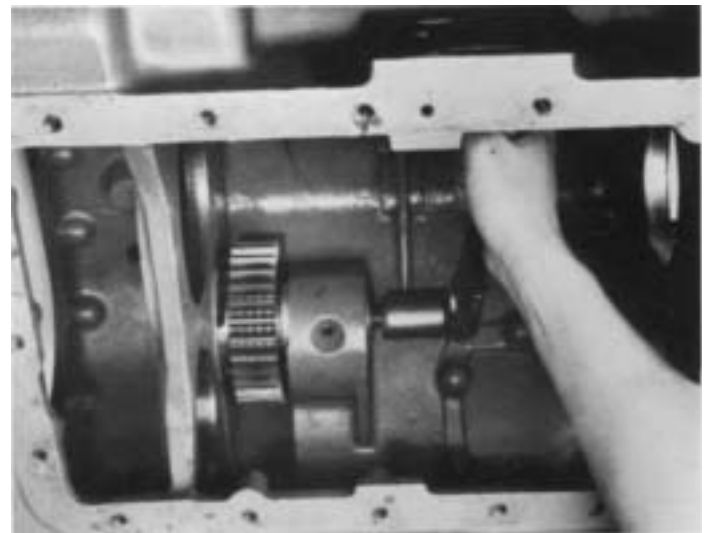

3. Making sure that the reverse idler shaft is seated in bore of support boss and forward as far as possible, install the washer and stop nut on front of shaft. Tighten nut to recommended torque rating.

# REASSEMBLY - FRONT SECTION

---

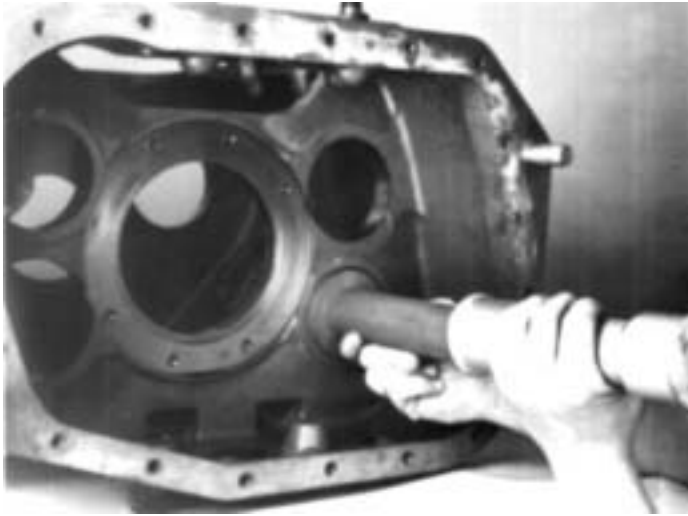

4. Install the OUTER RACE of auxiliary countershaft front bearing into case bore.

NOTE: The bearing INNER RACE is installed on front of auxiliary countershaft and never with outer race.

## C. Reassembly of Countershaft Assemblies

NOTE: Except for the PTO gears, the left and right countershaft assemblies are identical and reassembled in the same manner.

NOTE: Reverse low, 1st and 2nd speed gears are part of the shaft and are not serviceable.



1. Press the 3rd speed gear on the countershaft, long hub of gear to countershaft front.

# REASSEMBLY - FRONT SECTION

---



2. Start the PTO gear onto countershaft, bullet-nose side of teeth facing up and toward rear of shaft. Align key-way of drive gear with key in countershaft and press BOTH gears onto shaft, long hub of drive gear against PTO gear.

**NOTE:** The left countershaft assembly has a 47-tooth PTO gear; the right countershaft assembly has a 45-tooth PTO gear.

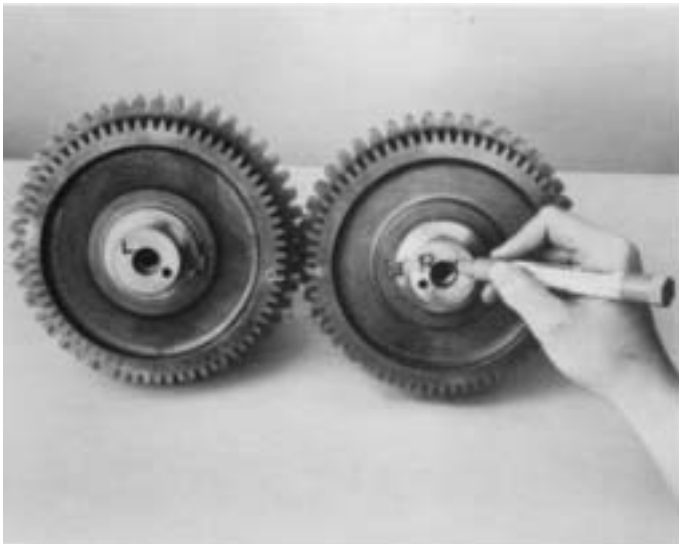

3. To avoid confusion during installation, mark the end of left countershaft with an "L", the end of right countershaft with an "R".

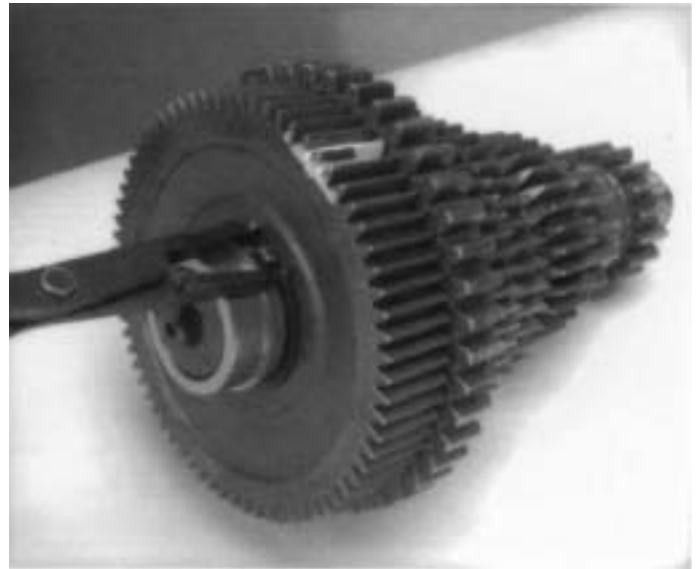

4. Install the drive gear retaining snap ring in groove on front of each countershaft.



5. Use a flanged-end driver to install bearing inner race on countershaft, shoulder of race against shoulder of countershaft.

# REASSEMBLY - FRONT SECTION

---

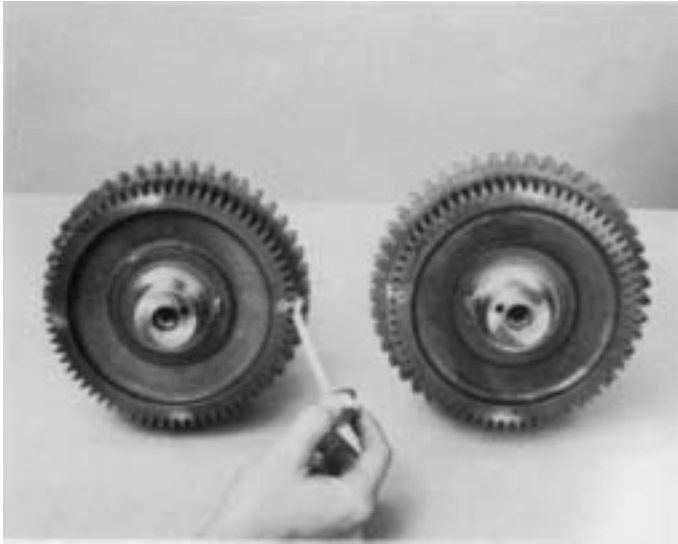

**IMPORTANT:** Mark the countershaft drive gear for timing purposes. On the drive gear of each countershaft assembly, mark the tooth aligned with keyway of gear and stamped with an "O" for easy identification. A highly visible color of toolmakers' dye is recommended for making timing marks.

## E. Partial Installation of Countershaft Assemblies

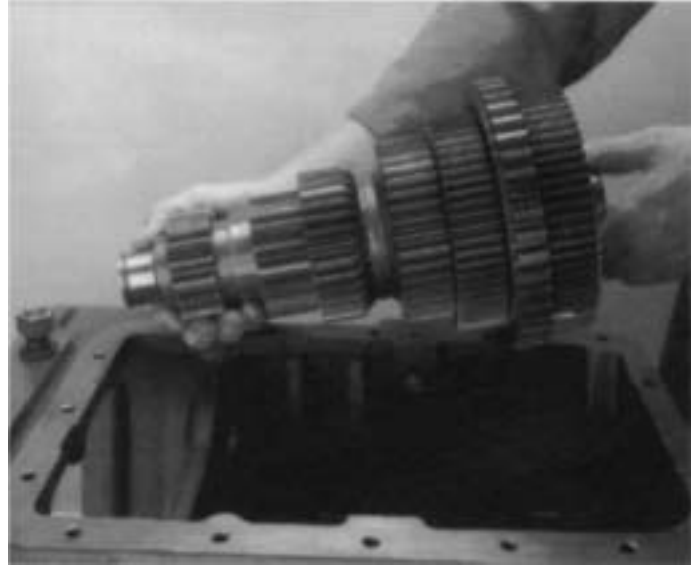

1. Place the left countershaft assembly into position in case, making sure that the "L"-marked assembly has the larger 47-tooth PTO gear. Place the right countershaft assembly into position in case, making sure that the "R"-marked assembly has the smaller 45-tooth PTO gear.

# REASSEMBLY-FRONT SECTION

## F. Bearing Installation of Left Countershaft Assembly



1. Move the left countershaft assembly to the rear and insert countershaft support tool or blocking to center shaft in rear case bore.



3. Center the front of left countershaft in bearing and move the assembly forward.



2. Use a flanged-end bearing driver to start the bearing in case bore.

NOTE: The inner race of roller-type front bearing is pressed on front of countershaft.



4. Use a flanged-end bearing driver to completely seat front bearing or bearing outer race in case bore.



# REASSEMBLY - FRONT SECTION

## F. Reassembly, Installation and Timing of Main Drive Gear Assembly

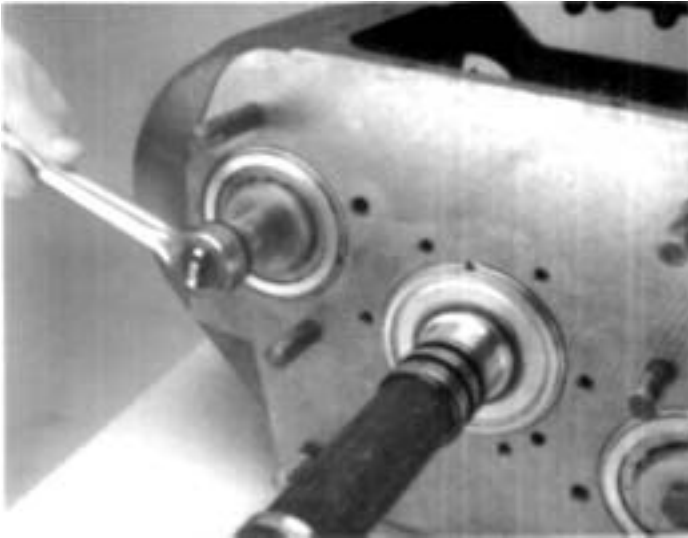

5. Position the retainer plate on front of left countershaft, roll pin in hole at end of shaft, and secure with capscrew tightening to recommended torque.

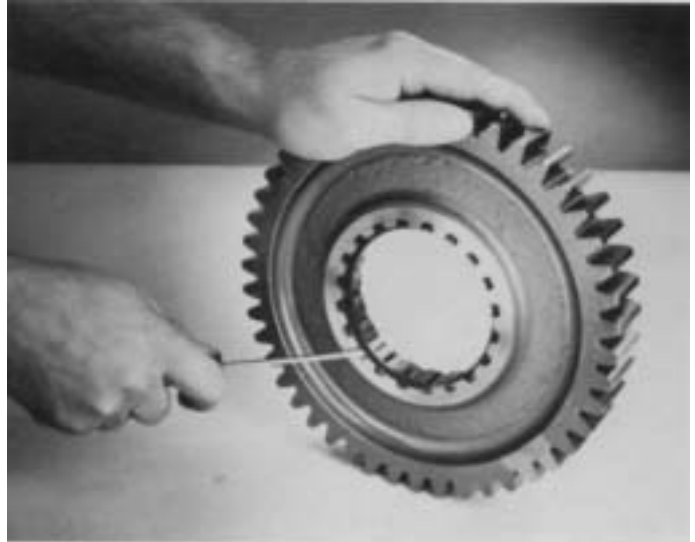

1. Install the snap ring in I.D. of main drive gear.

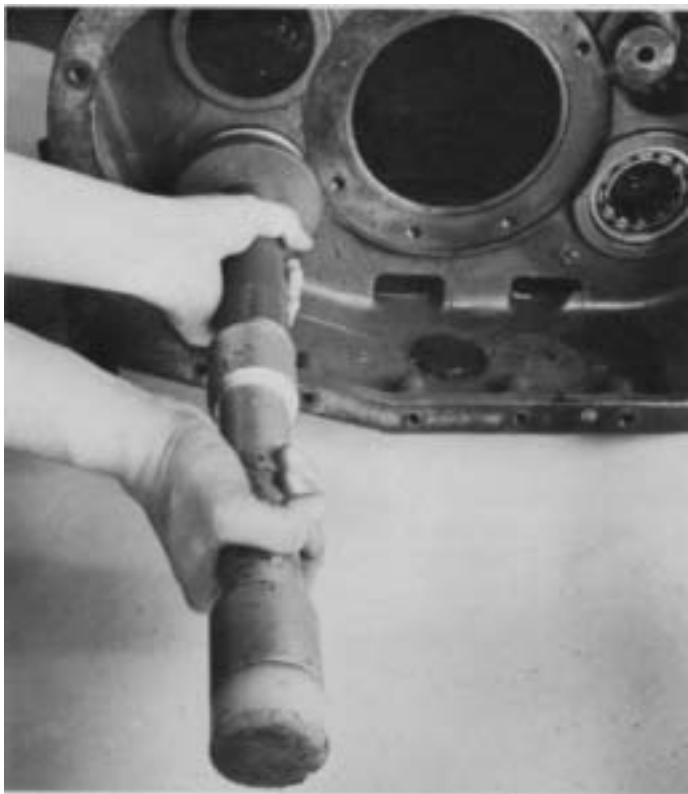

6. Remove countershaft support tool or blocking from rear case bore and install the left countershaft rear bearing with larger I.D. lead chamfer to the front of shaft and install the snap ring in groove at rear of left countershaft.



2. Mark the main drive gear for timing purposes. Mark any two adjacent teeth on drive gear and repeat the procedure for the two adjacent teeth directly opposite the first set marked. A highly visible color of toolmakers' dye is recommended for making timing marks.

# REASSEMBLY - FRONT SECTION



3. Mesh the marked tooth of left countershaft drive gear with either set of two marked teeth on main drive gear. Slide the input shaft through the main drive gear (inset).

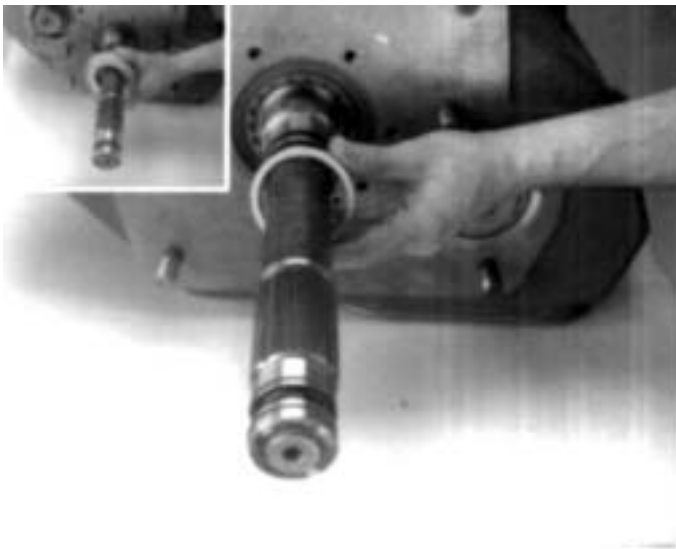

4. Install drive gear spacer. Install the bearing on the input shaft with external snap ring to the outside (inset). Set input shaft bearing into the bore of the case front.



5. Place two lifting eyes with capscrews over bearing snap ring to temporary secure bearing in transmission bore.

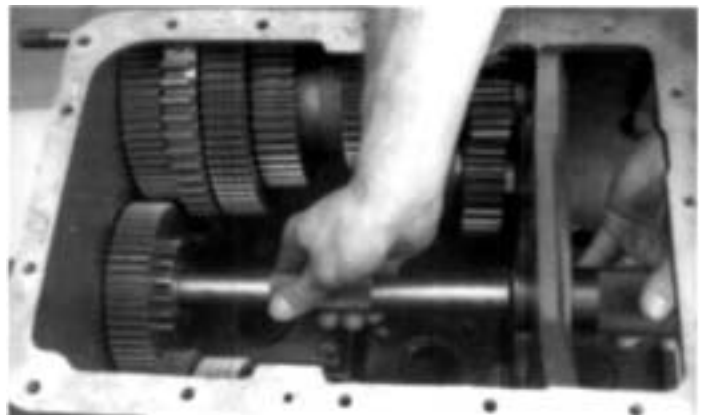

6. Use a soft bar and maul to drive the input shaft through bearing. Remove front bearing cover.



7. Install bearing retainer snap ring to secure input shaft in case bore. Remove the two capscrew and lifting eyes.

# REASSEMBLY - FRONT SECTION

## H. Reassembly and Partial Installation of Mainshaft Assembly

1. If previously removed, install the corresponding snap rings in I.D. of mainshaft gears.

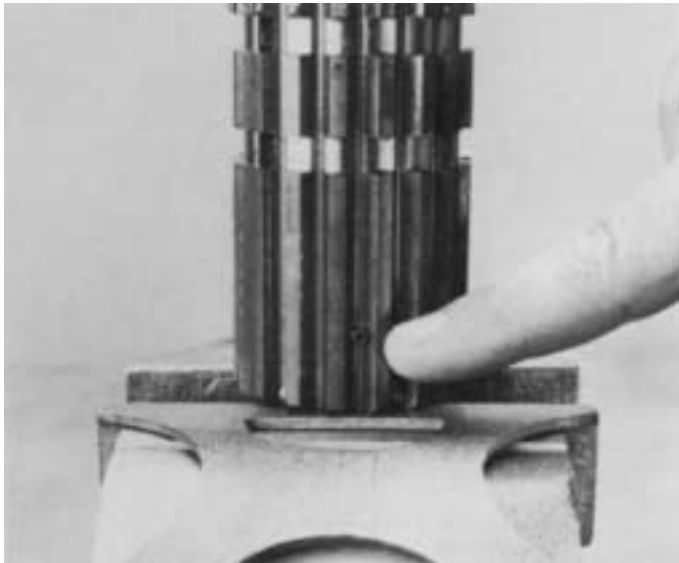

2. Secure the mainshaft in a vise equipped with brass jaws or wood blocks, pilot-end of shaft down. If previously removed, install the roll pin in keyway.

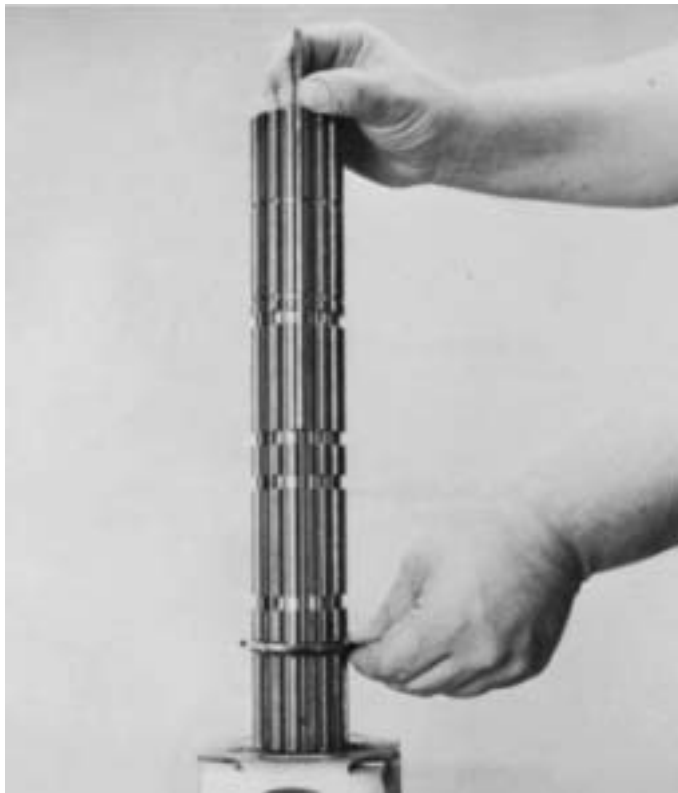

3. Install the 3rd speed gear limit washer on mainshaft, flat side of washer up. Rotate washer in the 1st or bottom groove of mainshaft to align the splines of washer with those of the mainshaft. Install the key in mainshaft keyway to lock washer in place.



4. Install the spacer on shaft against washer.



5. Install the 3rd speed gear on mainshaft, clutching teeth down and engaged with external splines of spacer.

**NOTE:** Gear limit washers are internally splined and locked to mainshaft by the key. Gear spacers are externally splined to engage with clutching teeth in gear hubs. There is one limit washer and one spacer for each gear in the mainshaft assembly.

# REASSEMBLY—FRONT SECTION

## Setting Correct Axial Clearances For Mainshaft Gears

Axial Clearance (End-Play) Limits Are:  
 .005" -.012" for all mainshaft gears

Washers are used to obtain the correct limits; six thicknesses are available as follows:

LIMITS (INCH)	COLOR CODE
.248 -.250	WHITE
.253 -.255	GREEN
.258 -.260	ORANGE
.263 -.265	PURPLE
.268 -.270	YELLOW
.273 -.275	BLACK
	"PLUS RED"

**\*NOTE:** New style tolerance washers come in a full range of tolerances as corresponding colors listed above "plus red." (Example: "Orange plus red" limit washer has an inch limit thickness of .258-.260.)

Refer to Illustrated Parts Lists for washer part numbers.

Always use the .248 -.250 tolerance washer ("White" or "white plus red") in the reverse, LO and 2nd speed gear positions as shown at right.

**IMPORTANT: REFER TO THE APPROPRIATE ILLUSTRATED PARTS LIST (SPECIFIED BY MODEL SERIES) TO ENSURE THAT PROPER PARTS ARE USED DURING REASSEMBLY OF THE TRANSMISSION.**

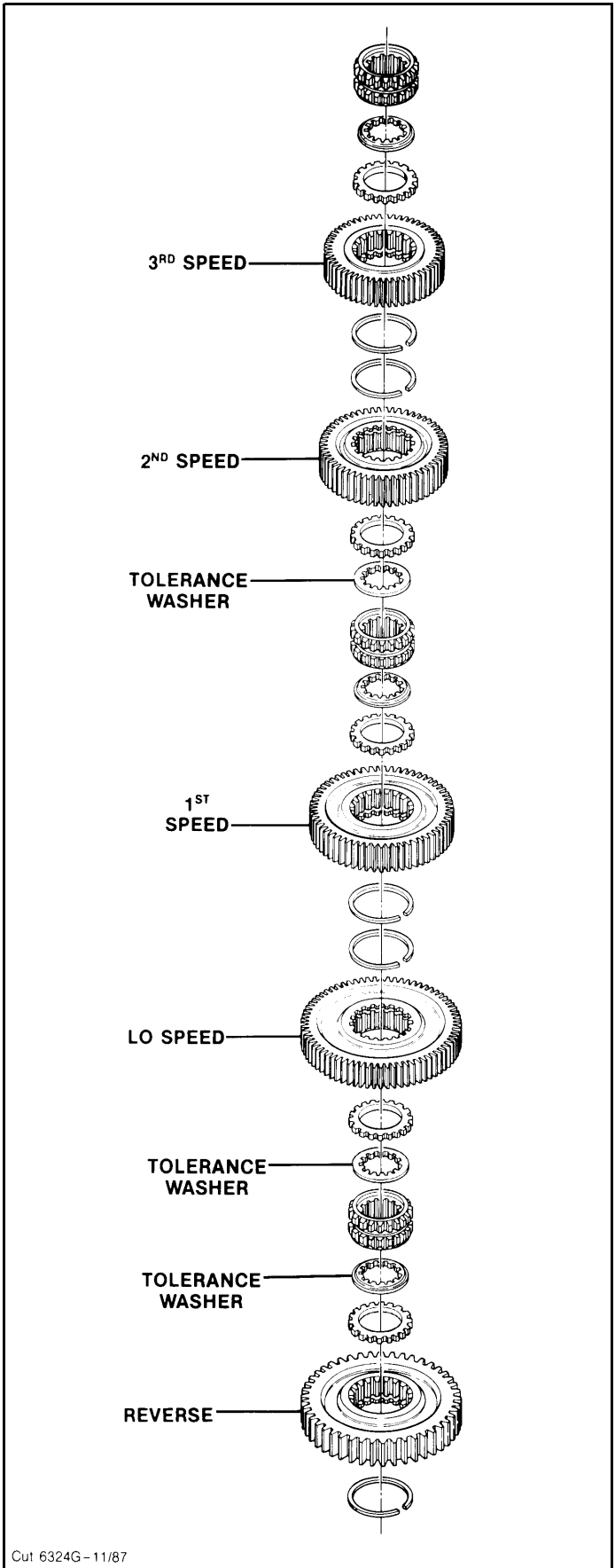

# REASSEMBLY-FRONT SECTION

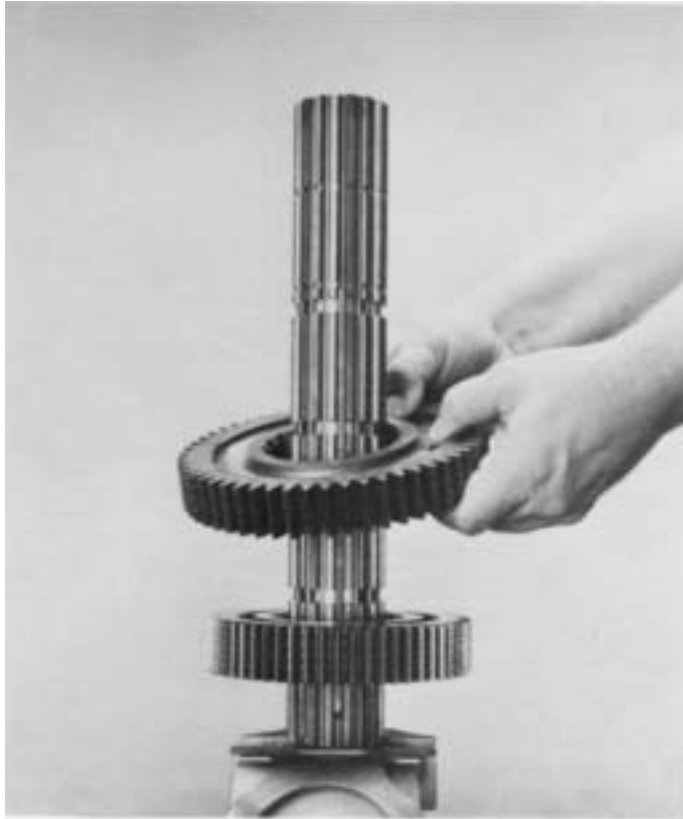

6. Install the 2nd speed gear on shaft against 3rd speed gear, clutching teeth up.

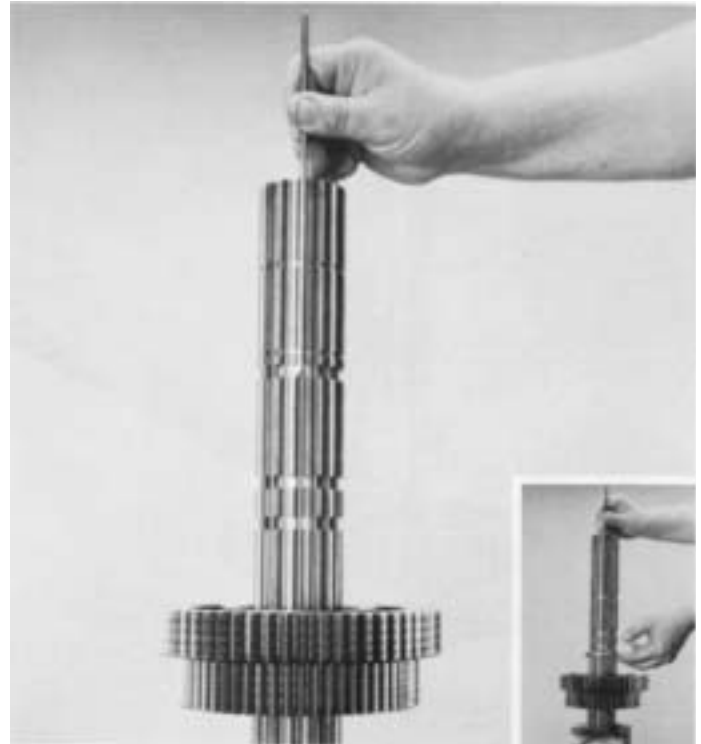

8. Remove the key from keyway and install the 2nd speed gear limit washer on mainshaft, flat side of washer down and against spacer. Rotate washer in the 2nd groove of mainshaft to align the splines of washer with those of the mainshaft and reinsert key in keyway to lock washer in place (inset).

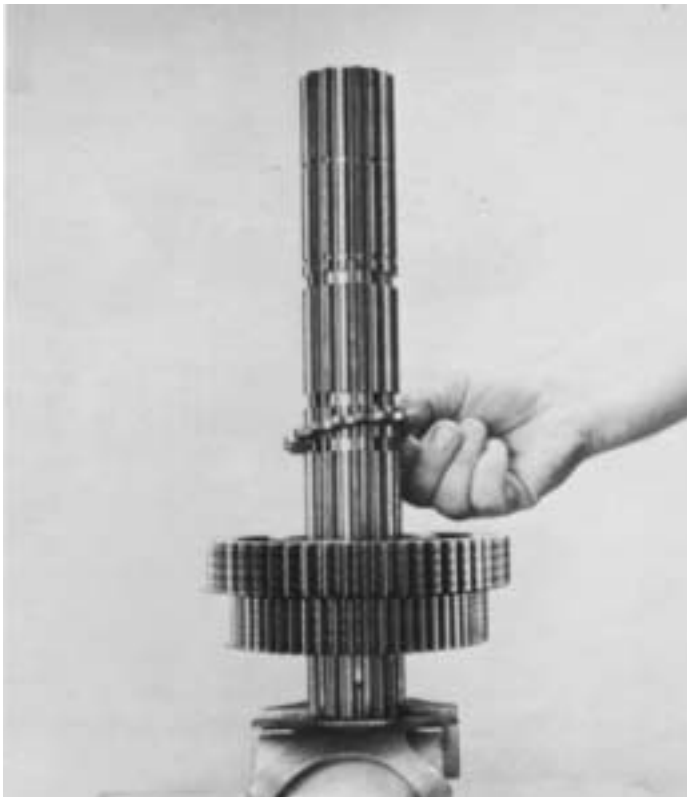

7. Install the spacer in 2nd speed gear, engaging the external splines of spacer with clutching teeth of gear.

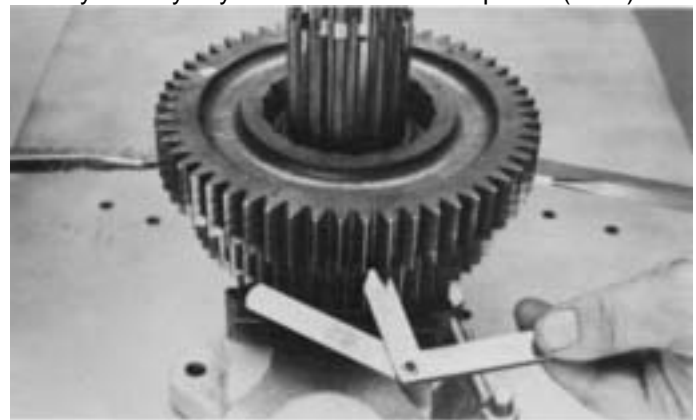

9. Insert two large screwdrivers between the 2nd and 3rd speed gears to check axial clearances. Apply slight downward pressure on screwdriver handles to spread gears evenly. Making sure the gear hubs are parallel, insert a feeler gage between hubs. Correct axial clearance is less than the minimum .005" to .012". If the clearance is less than the minimum .005" tolerance, the limit washer in the 2nd speed gear should be replaced by a thinner limit washer. This will increase the axial clearance between the gears. If the clearance checked is greater than the maximum .012" tolerance, a thicker limit washer should be installed in the 2nd speed gear. This would decrease the axial clearance between the gears.

# REASSEMBLY-FRONT SECTION

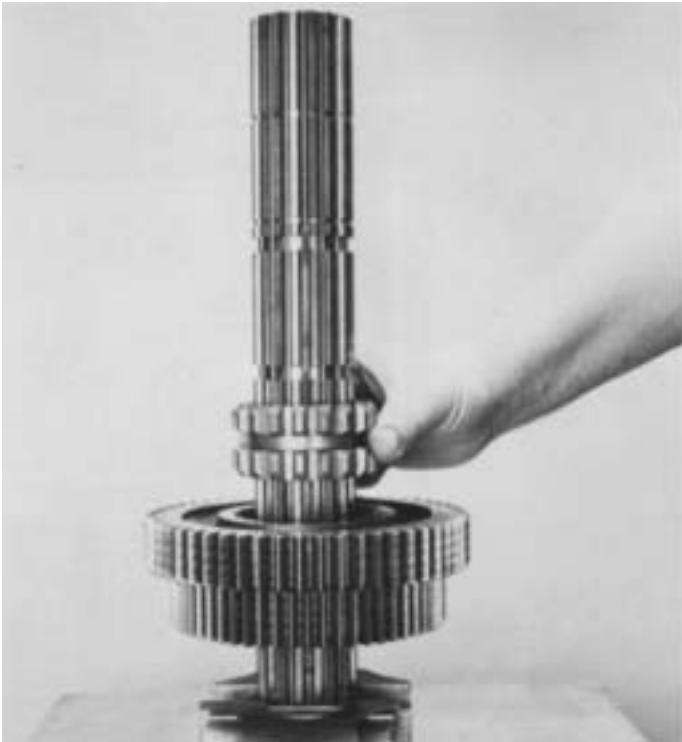

10. Install the 1st-2nd speed sliding clutch, aligning the missing internal spline of sliding clutch with key in mainshaft.

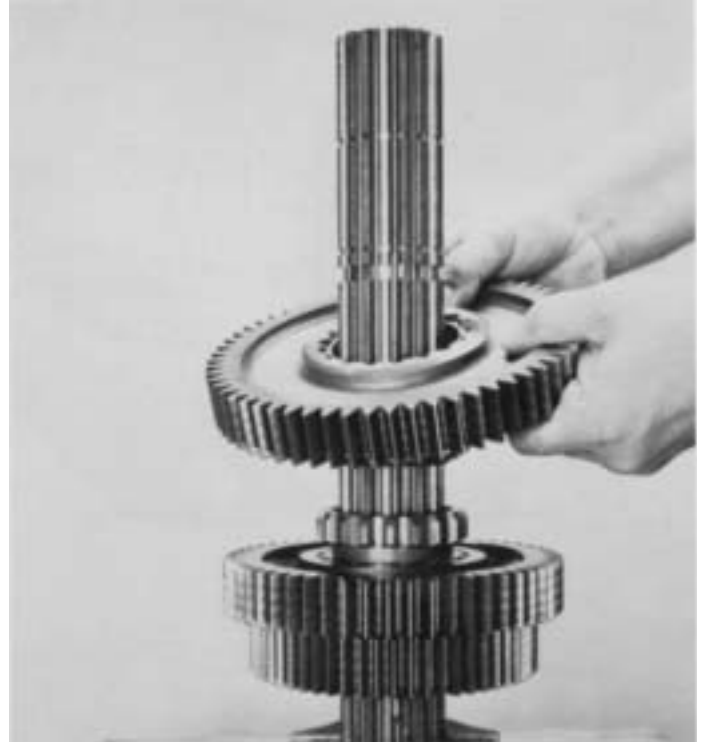

12. Install spacer and 1st speed gear on the mainshaft, clutching teeth down and engaged with external splines of spacer.

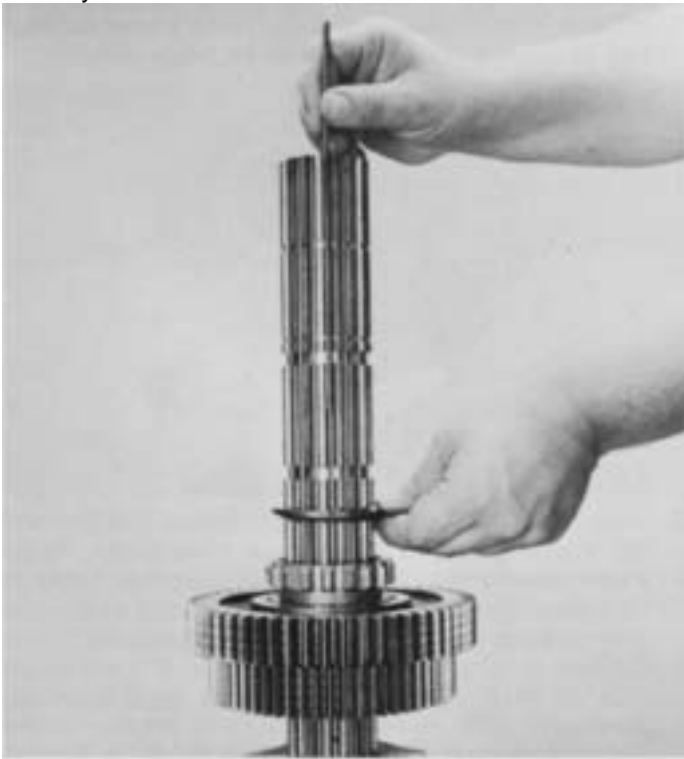

11. Remove the key from keyway and install the 1st speed gear limit washer on mainshaft, flat side of washer up. Rotate washer in the 2nd groove of mainshaft to align the splines of washer with those of the mainshaft and reinsert key in keyway to lock washer in place.

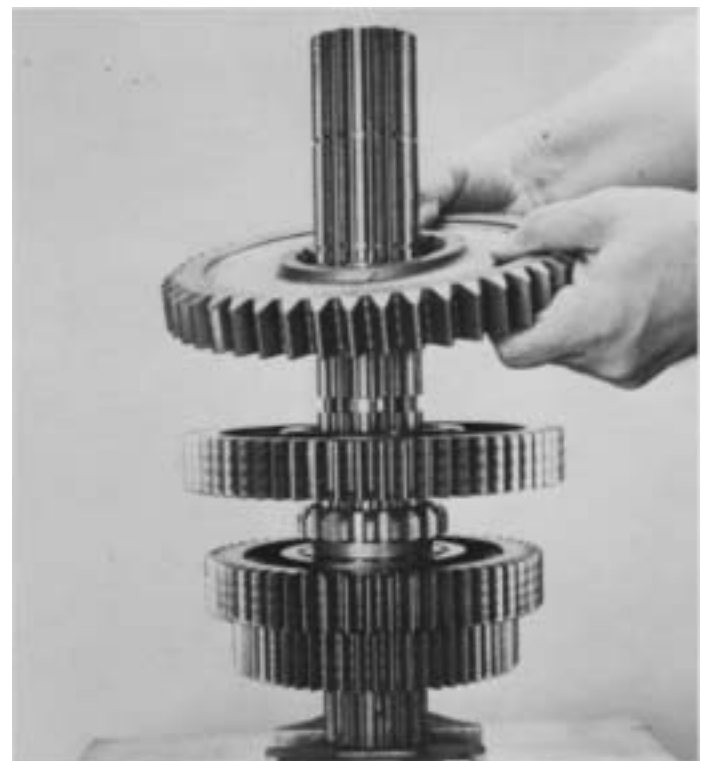

13. Install the LO speed gear on shaft against 1st speed gear, clutching teeth up.

# REASSEMBLY-FRONT SECTION

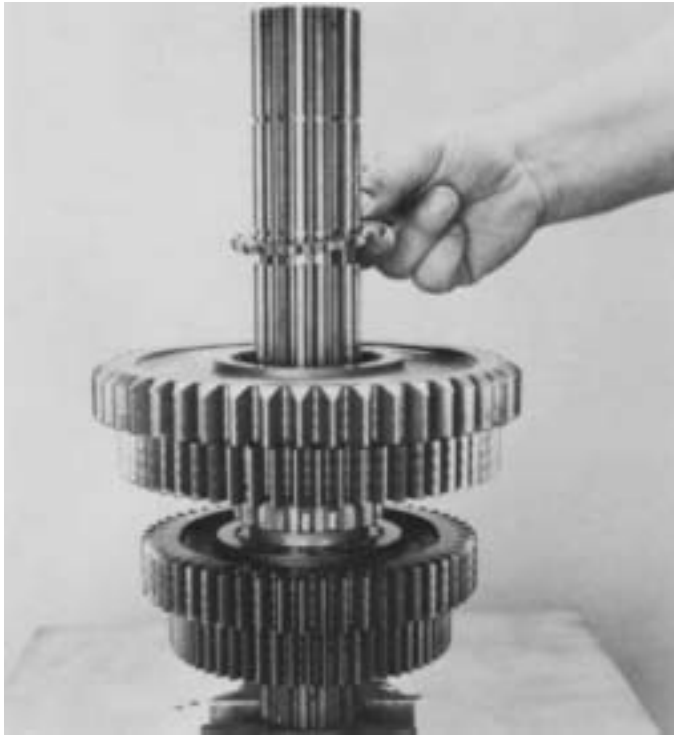

14. Install the spacer in LO speed gear, engaging the external splines of spacer with clutching teeth of

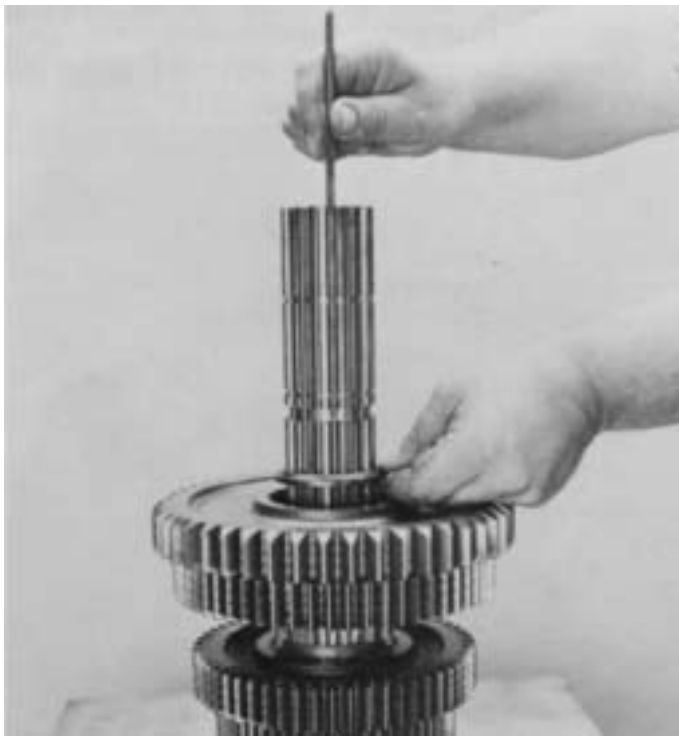

15. Remove the key from keyway and install the LO speed gear limit washer on mainshaft, flat side of washer down and against spacer. Rotate washer in the 4th groove of mainshaft to align the splines of washer with those of the mainshaft and reinsert key in keyway to lock washer in place.

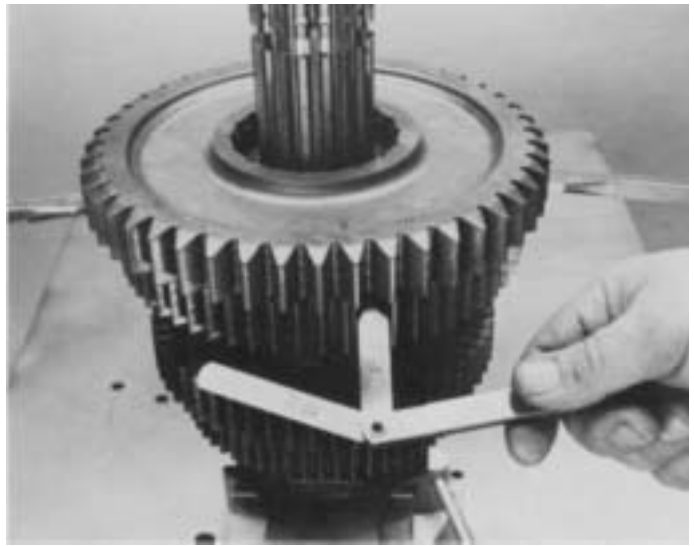

16. Check axial clearances and make adjustments, if necessary, between the LO and 1st speed gears as described in No. 9 of this section.

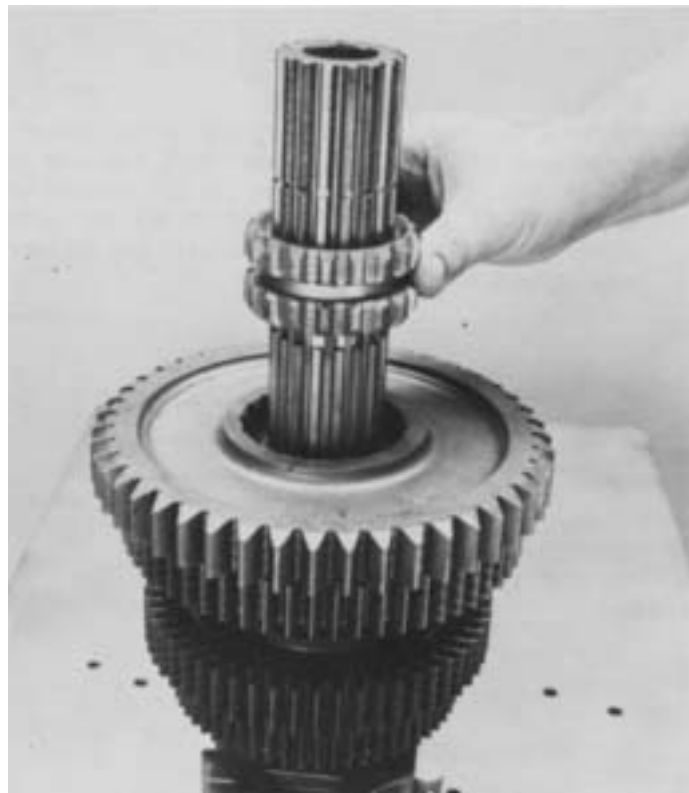

17. Install the LO-Reverse speed sliding clutch, aligning the missing internal spline of sliding clutch with key in mainshaft.

# REASSEMBLY-FRONT SECTION

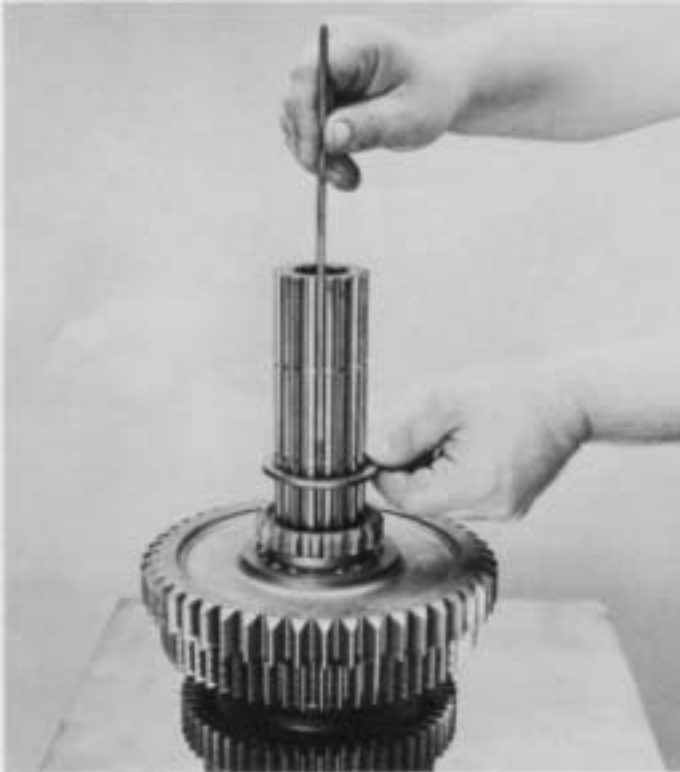

18. Remove the key from keyway and install the reverse gear limit washer on mainshaft, flat side of washer up. Rotate washer in the 5th groove of mainshaft to align the splines of washer with those of the mainshaft and reinsert key in keyway to lock washer in place.

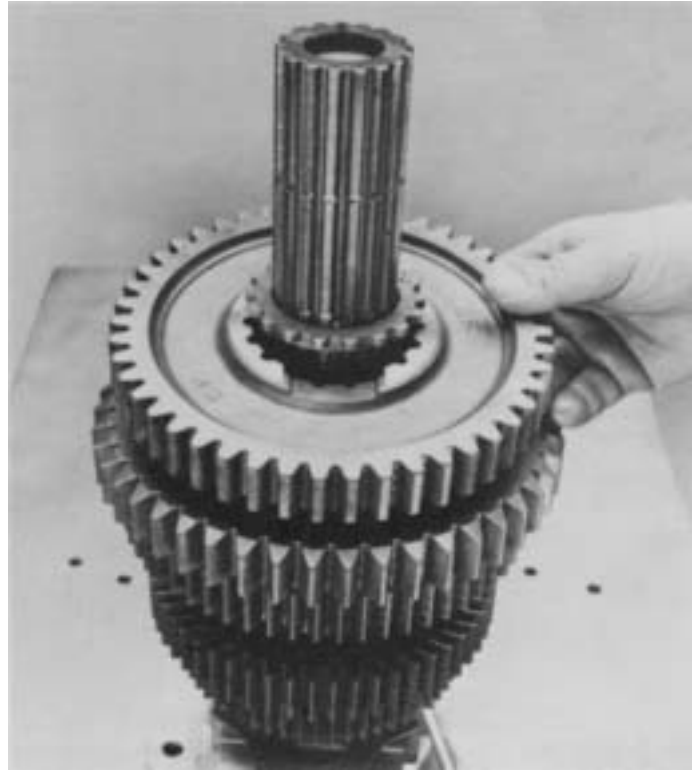

20. Install reverse gear on mainshaft. Engage the clutching teeth of gear with splines of spacer and sliding clutch and move the reverse gear against the LO speed gear.

**NOTE:** DO NOT REPLACE REVERSE GEAR INTERNAL SNAP RING AT THIS STEP

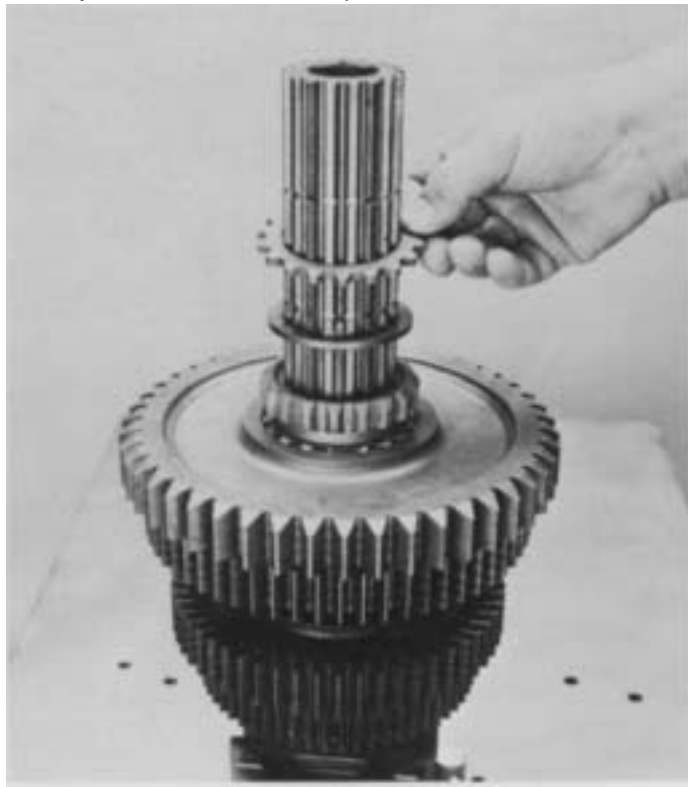

19. Install the spacer on shaft against washer.



21. Remove the mainshaft assembly from vise. Align the missing internal spline of 3rd-4th speed sliding clutch with key in mainshaft and install on front of shaft, engaging the external splines of sliding clutch with clutching teeth of 3rd speed gear.



# REASSEMBLY-FRONT SECTION

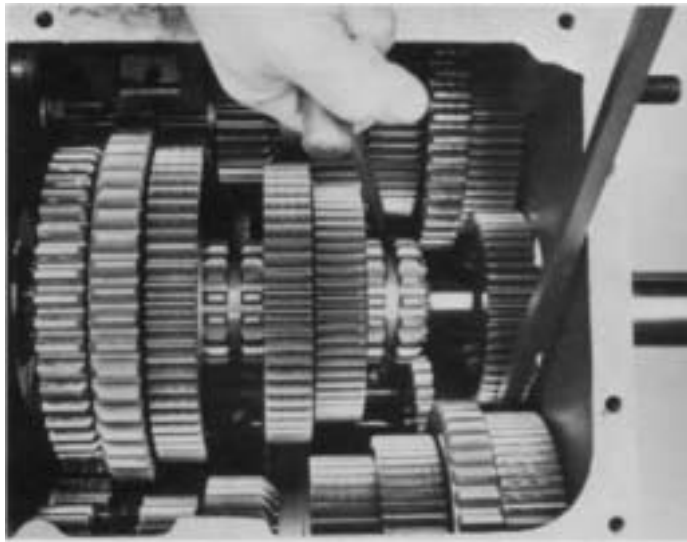

22. Block the right countershaft assembly against case wall and lower the mainshaft assembly into position with the reverse gear held against LO speed gear and rear of shaft moved into case bore.

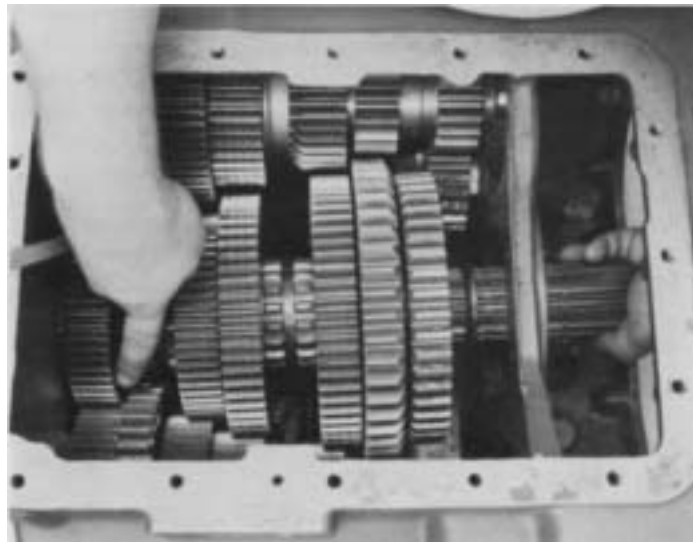

24. With the reverse gear remaining against LO speed gear, mesh the corresponding forward speed gears of left countershaft assembly. Check to make sure that marked tooth on left countershaft drive gear has remained in mesh with marked set of teeth on main drive gear.

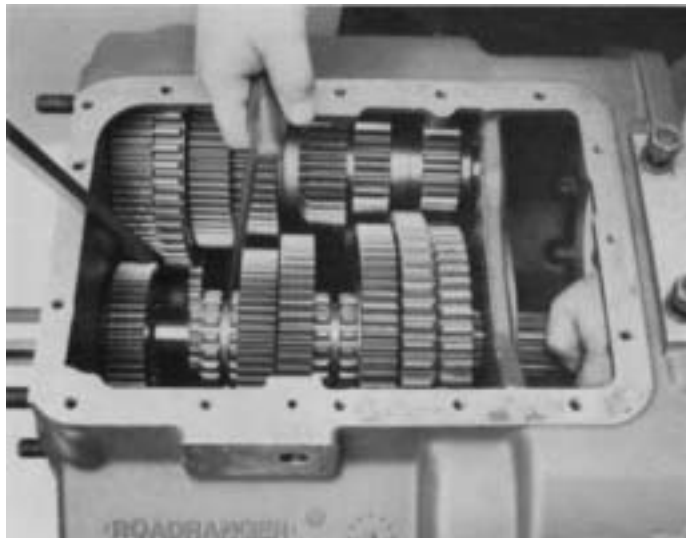

23. Move the pilot-end of mainshaft into pocket bushing of input shaft.

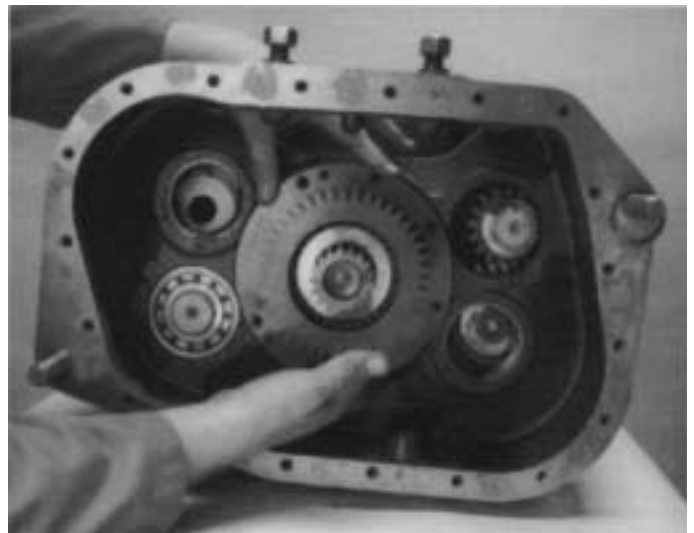

25. Center rear of mainshaft in case bore and install the auxiliary drive gear assembly on shaft, partially seating the bearing in bore. DO NOT COMPLETE INSTALLATION AT THIS TIME.

# REASSEMBLY - FRONT SECTION

## H. Bearing Installation and Timing of Right Countershaft Assembly

**IMPORTANT:** The left countershaft assembly **MUST** remain in time with main drive gear when timing right countershaft assembly.

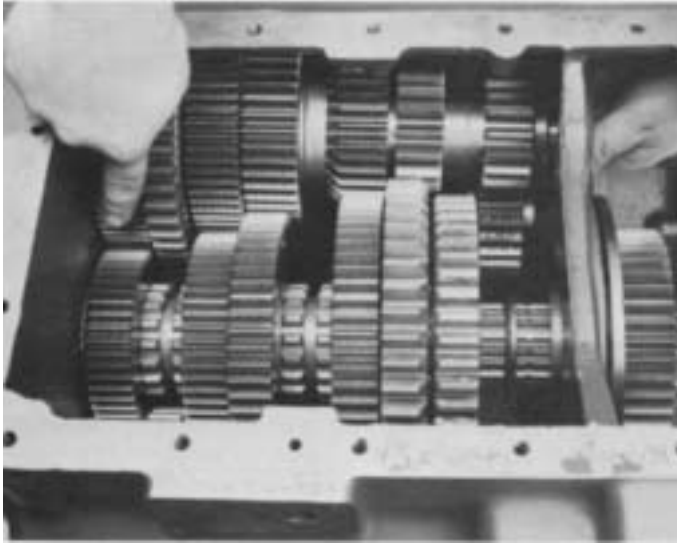

1. Remove blocking from right countershaft assembly and place it parallel to mainshaft assembly. Mesh the marked tooth of right countershaft drive gear with remaining set of two marked teeth on main drive gear.

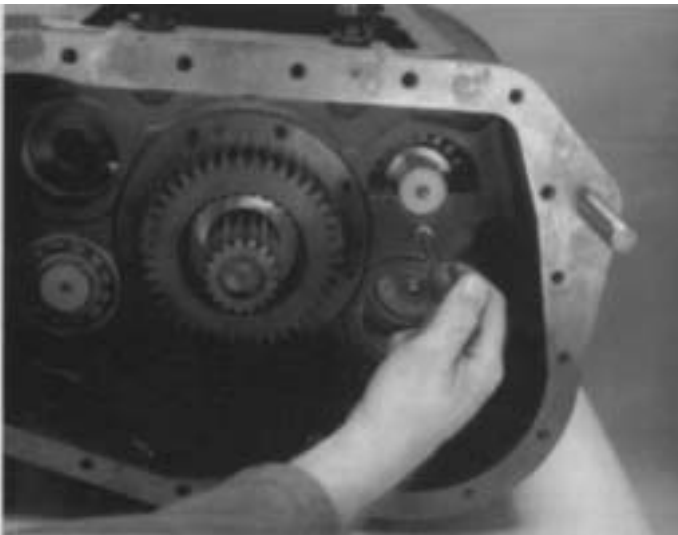

2. Insert countershaft support tool or blocking in rear bearing bore.

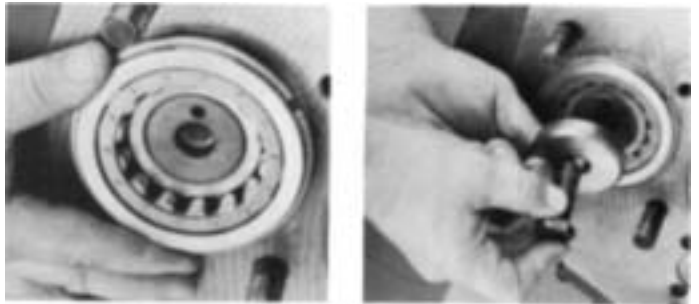

3. Position the front countershaft bearing in front bearing bore. Use the proper bearing driver to set the bearing in bore (left). Install retainer washer and cap screw. Make sure to match roll pin in retainer with inner bearing hole (right).

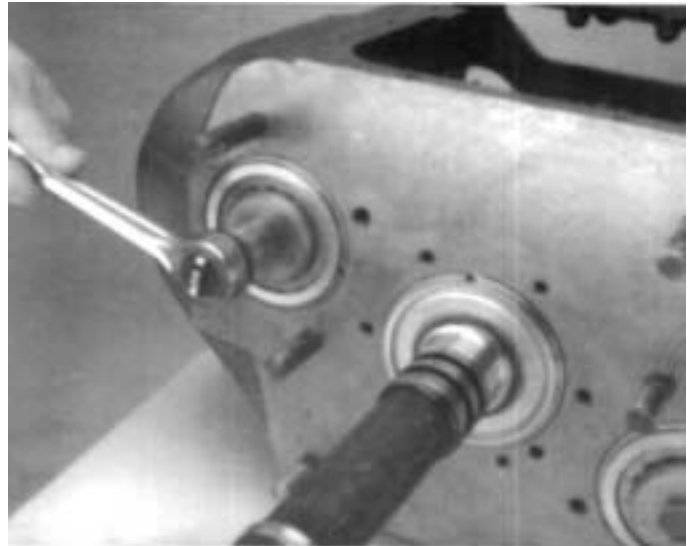

4. Tighten cap screw to the recommended torque.

# REASSEMBLY - FRONT SECTION

---



5. Position the countershaft rear bearing in rear bearing bore. Use the proper bearing driver to seat bearing in bore.

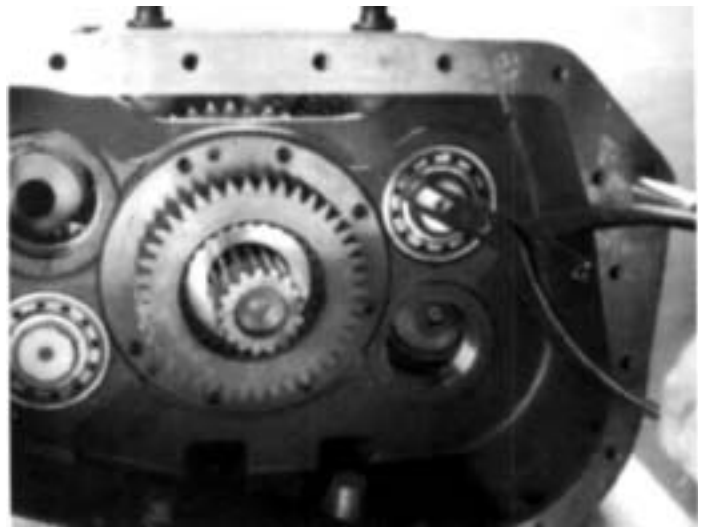

6. With bearing installation complete, install the snap ring in right countershaft rear groove.
7. Move the reverse gear to the rear on mainshaft and use a screwdriver to engage sliding clutches with all forward speed gears. A sliding clutch that will not engage with a gear indicates the gear set is not in proper mesh. The bearings of the right countershaft would then need to be removed and the drive gear set retimed.

NOTE: Do not engage sliding clutches with more than one gear at the same time. This will lock the gearing and prevent the mainshaft and countershaft assemblies from rotating.

# REASSEMBLY - FRONT SECTION

## 1. Reassembly and Installation of Left Reverse Idler Gear Assembly

**NOTE:** Since the left and right reverse idler gear assemblies are identical, reassembly and installation of the left reverse idler gear assembly should be performed at this time as described in Part C of this section.

## J. Completed Installation of Mainshaft and Auxiliary Drive Gear Assemblies



3. Install the snap ring in hub of reverse gear and move the reverse gear forward on mainshaft and into proper position in case.



1. Move the reverse gear to the rear as far as possible, meshing teeth of gear with those of the reverse idler gears.



4. Install snap ring on mainshaft snap ring groove.

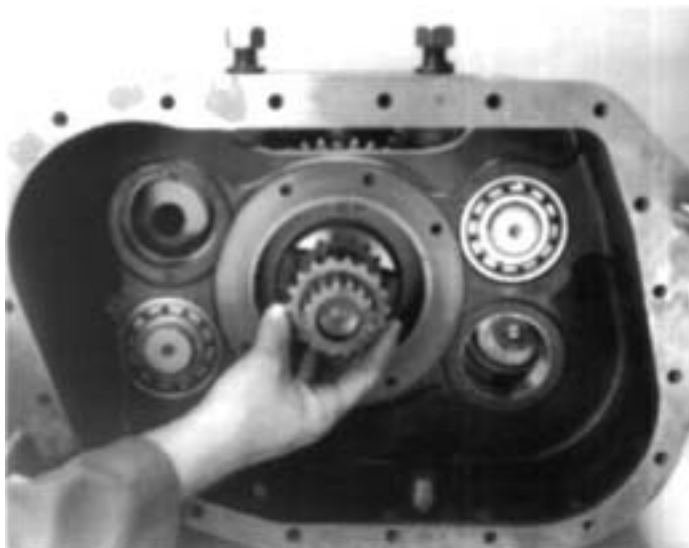

2. Align the external splines of spacer with clutching teeth of reverse gear and move spacer forward on the mainshaft and into reverse gear.



5. Install splined washer on mainshaft splines behind reverse gear.

# REASSEMBLY - FRONT SECTION

---



6. Reinstall the front auxiliary drive gear assembly on rear of mainshaft. Use a flanged-end driver and maul to set bearing in case bore.



8. Install splined washer on mainshaft splines behind auxiliary drive gear.

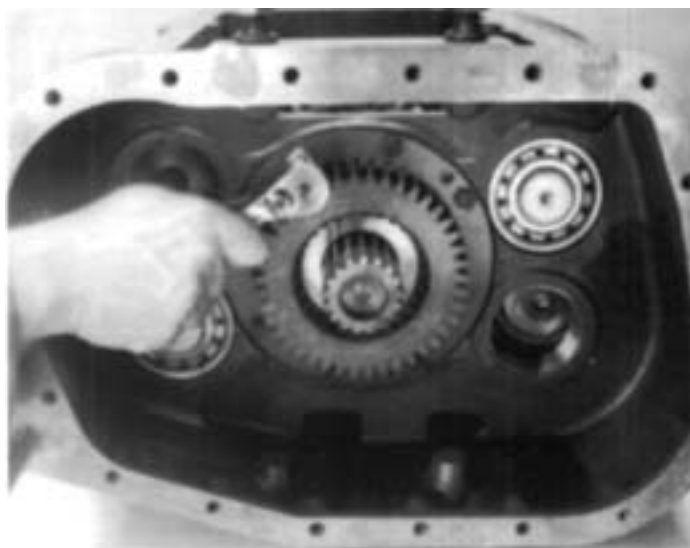

7. Align the six capscrew holes in retainer with the tapped holes in case and install capscrews. Tighten to recommended torque ratings and lockwire the capscrews in groups of three.

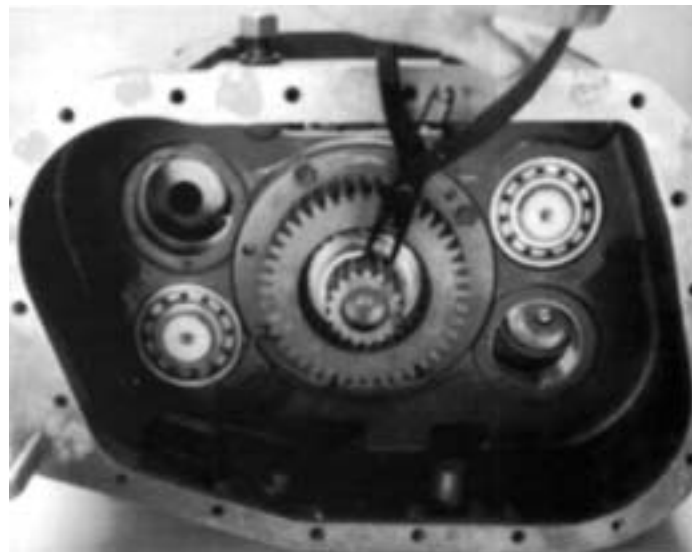

9. Install the snap ring in groove at end of mainshaft.

# INSTALLATION - TORQUE CONVERTER HOUSING OUTPUT YOKE, AUXILIARY SECTION AND SHIMMING PROCEDURE

## A. Installation of Torque Converter Housing

**Note:** The transmission rear must be blocked so the two aligning pins on the transmission rear case are not damaged. If the auxiliary section has been installed the transmission can be placed vertically on a stand using an output flange or half round yoke affixed to a large plate.

**CAUTION** Care must be taken when placing the transmission in the vertical position. Always use safety chains on the transmission. Assure that the transmission is stable in the vertical position before removing the safety chains.



2. Place the oil pump on the torque converter housing opening (left). Install the two retaining cap screws and properly torque the cap screws (right).

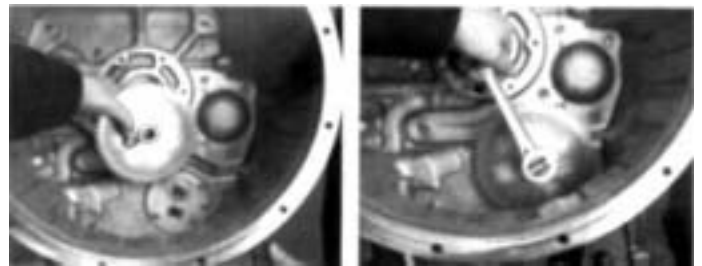

3. Install the oil pump drive gear on the pump shaft and thread retaining locknut in place (left). Block the oil pump drive gear and tighten lock nut to proper torque.

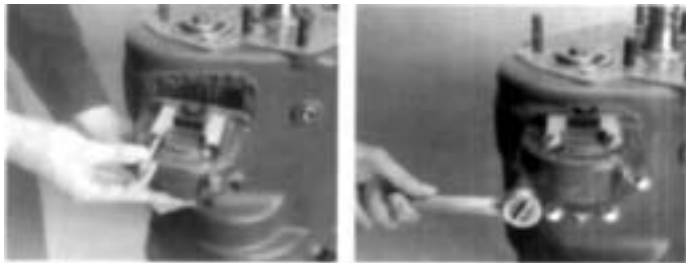

1. Place the inertia brake, gasket and six (6) retaining cap screws on the transmission case (left). Tighten the six (6) retaining cap screws to required torque specifications.

## C. Installation of the Torque Converter Housing

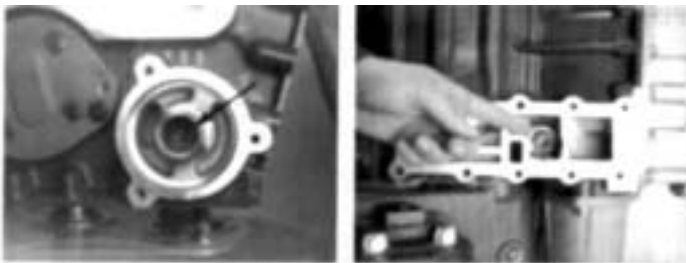

1. If the pressure relief valve was replaced check for proper seating and secure the valve (left). After replacing the filter by-pass valve the valve should be properly seated and secured (right).



4. Place the torque converter housing gasket and torque converter housing onto the front of the main case (left). Install the four (4) retaining cap screws and six (6) retaining nuts and properly torque each retainer (right).



5. Install the shaft support and gasket over the input shaft down into the torque converter housing (left). Install the six (6) retaining cap screws and properly torque cap screws.

# INSTALLATION - TORQUE CONVERTER HOUSING OUTPUT YOKE, AUXILIARY SECTION AND SHIMMING PROCEDURE

## D. Installation of Oil Pan, Pick Up and Screen and Oil Filter Assembly



1. Install the oil filter o-ring seal, oil filter and oil filter housing onto the torque converter housing and tighten three (3) retaining capscrews to required torque.



2. Place the oil pan gasket on the mounting surface and install the pick-up screen assembly in place with the three (3) retaining capscrews.



3. Place the oil pan over pick-up and screen onto the torque converter housing (left). Secure the oil pan to the torque converter housing with the retaining capscrews (right).

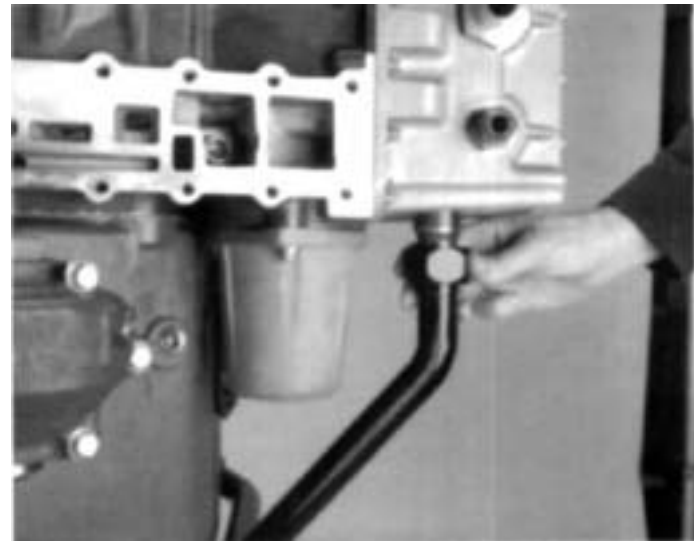

4. Install the oil sump return tube to the oil pan. Check the fittings at the oil pan and transmission for proper torque.

## E. Installation of the Hydraulic Valve



1. If the electronic solenoids were removed place them back on the hydraulic valve and secure them with their retaining nuts (left). Place the two (2) gaskets and mounting plate on hydraulic valve (right).

**NOTE:** Gaskets to hydraulic valve are marked for proper installation. The mounting plate should be checked for proper alignment.

# INSTALLATION - TORQUE CONVERTER HOUSING OUTPUT YOKE, AUXILIARY SECTION AND SHIMMING PROCEDURE



2. Install the hydraulic valve on the torque converter housing and align mounting holes (left). Install the ten (10) retaining cap screws into the hydraulic valve. Note two (2) of the retaining cap screws are allen head cap screws check their location (right).

**NOTE:** The transmission dipstick tube can be reinstalled on the transmission at this time.

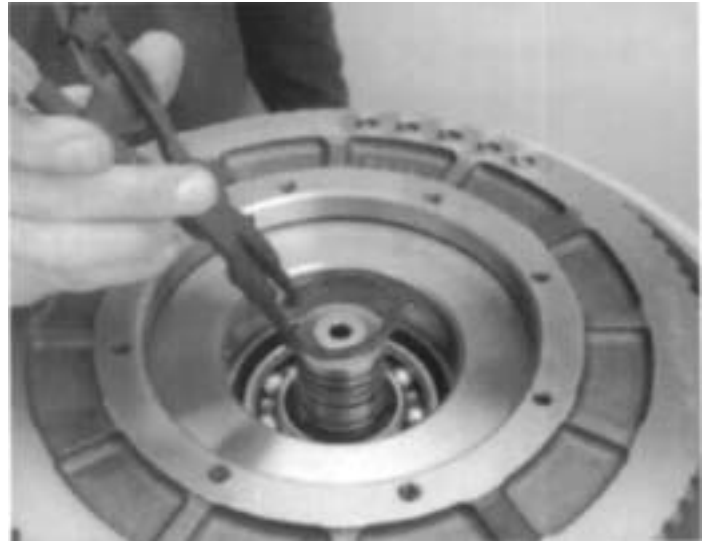

## F. Installation of the Torque Converter

2. After the torque converter is properly seated exposing the snap ring groove install the snap ring.



1. Install two (2) lifting eyes into the converter pilot cap screw holes. Attach a lifting chain to lifting eyes lower torque onto the input shaft into the torque converter housing.

**NOTE:** The torque converter may not seat itself completely on the shaft. Care must be taken during installation. Do not force the torque converter onto the input shaft as damage to internal splines will occur.

The splines on the input shaft must match those internal to the torque converter interrupt clutch splines. Not matching these splines will not allow the torque converter to properly slide onto the input shaft.



3. Install the torque converter pilot into the torque converter and properly seat the converter pilot (left). Install the eight (8) retaining cap screws into the converter pilot and properly torque the cap screws (right).



# INSTALLATION - CLUTCH HOUSING, OUTPUT YOKE, AUXILIARY SECTION AND SHIMMING PROCEDURE

---

## G. Installation of Output Yoke

**NOTE:** Replacement of seal and slinger must be completed prior to yoke or flange installation.

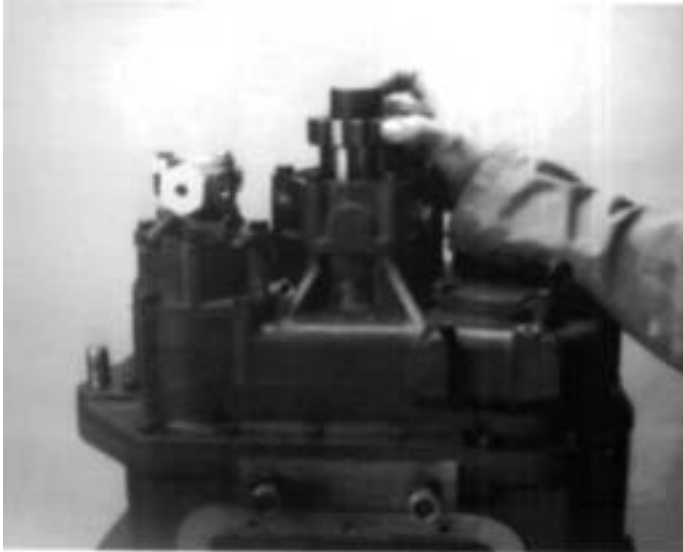

1. Install speedometer gear or spacer on output shaft.



3. Install washer and output nut onto the output shaft.

**NOTE:** It will be necessary to temporarily lock the transmission in two gears by moving sliding into gear for final torque procedure.



2. Place output yoke or flange onto the output shaft.



4. Complete installation process by torquing the output shaft nut to recommended torque.

# INSTALLATION - CLUTCH HOUSING, OUTPUT YOKE, AUXILIARY SECTION AND SHIMMING PROCEDURE

## H. Installation of the Auxiliary Section and Shimming Procedure

1. Tighten the middle bolt on each countershaft strap until the countershaft are snug. Shift the reduction sliding clutch into reduction. Attach a chain hoist to the output shaft.

**NOTE:** The front box sliding clutches must be in the neutral position.



2. With the transmission set in the vertical position, block under the torque converter housing to prevent damage to the torque converter, position the new gasket on the transmission case. Lower the auxiliary assembly on the front case rear.

**IMPORTANT:** Shift the reduction sliding clutch into deep reduction before installing the auxiliary.



3. Install the retaining cap screws in the housing flange and tighten to the recommended torque.



4. Remove the countershaft straps. Make sure a 0.125 countershaft rear bearing shim is installed. Be sure the countershaft rear bearing races are seated in the bearing bores.



5. Install two clean 3/8" x 1" capscrews without washers directly across from each other in each bearing cover. Tapped holes in auxiliary case must be free of thread adhesive.

# INSTALLATION - CLUTCH HOUSING, OUTPUT YOKE, AUXILIARY SECTION AND SHIMMING PROCEDURE



6. Tighten the capscrews to 7 in./lbs. of torque DO NOT INSTALL THE COUNTERSHAFT REAR BEARING COVER GASKET.



8. Remove the countershaft rear bearing covers and gauging shims.



7. Rotate the output shaft six times in the clockwise direction, then six times counterclockwise to seat the countershaft rear bearings. Use a feeler gauge, as close to one capscrew location as possible, and measure the gap between the countershaft rear bearing cover and the auxiliary case. Record the measurement. Using the average measurement, refer to page 115 in this Service Manual. Select the numbers in the left column that compare to the average measurement recorded from the countershaft rear bearing cover. Follow the column to the right to identify the proper shim to be used in the countershaft shim bores. Duplicate this procedure for the other countershaft rear bearing cover.



9. After the correct shim has been selected, place the shim on the rear countershaft bearing race, install the countershaft rear bearing cover and gasket. Check for proper shim alignment if misaligned rear bearing cover may be damaged when proper torque is applied. Position a new gasket on each countershaft rear bearing cover mounting surface and install both rear bearing covers. Install and tighten the capscrews to the recommended torque.

# INSTALLATION - SHIFTING CONTROLS

---

## A. Installation Shift Bar Housing



1. Place all three mainshaft sliding clutches in the neutral position. Install shift bar housing gasket in position.



2. With all three shift yokes in the neutral position, install the shift bar housing assembly on case, fitting the shift yokes into the slots of the corresponding sliding clutches.



3. Install the thirteen cap screws in shift bar housing and tighten to recommended torque rating.

**NOTE:** There are two sizes of cap screws. The 1 1/2" cap screws are used with lifting eyes.

# INSTALLATION - SHIFTING CONTROLS

## C. Installation of Slave Valve

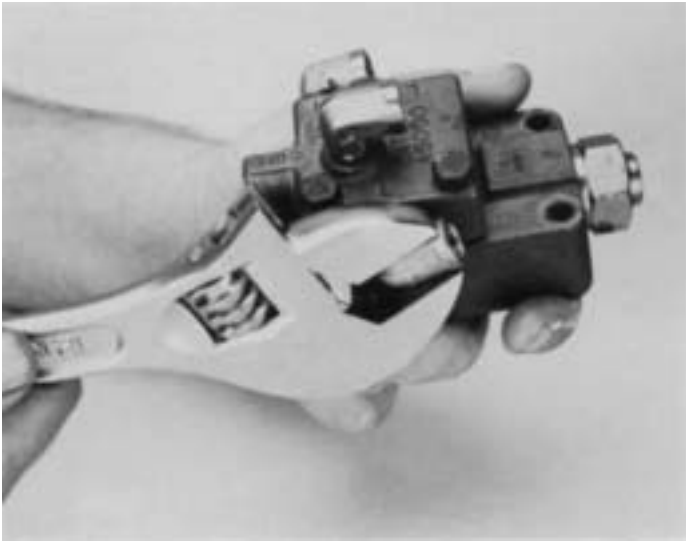

1. If previously removed, install the air line fittings on slave valve.



3. Install the hat-type alignment sleeve in bore of slave valve.



2. Install the spring on shank of actuating pin and insert in bore of transmission case.

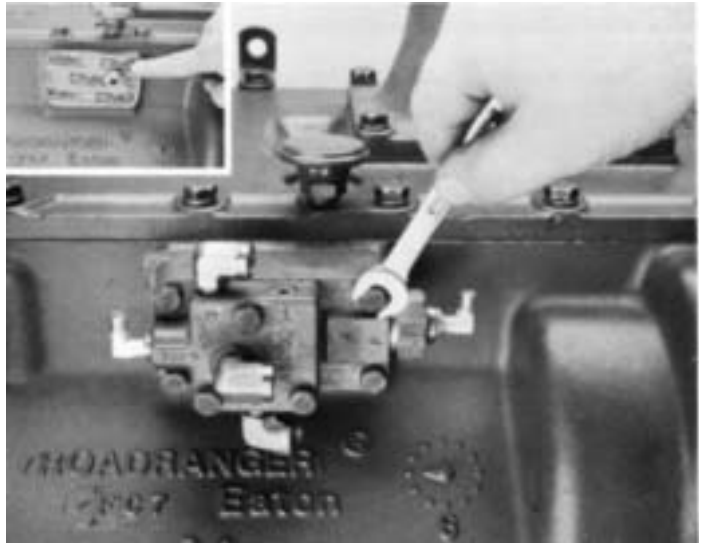

4. Position gasket on valve mounting surface (inset) and install the slave valve on case, inserting the end of actuating pin into alignment sleeve. Secure the valve to case with four cap screws tighten evenly to recommended torque rating.

# INSTALLATION - SHIFTING CONTROLS

---



1. Place the inertial brake air hose and wiring harness on the transmission.



2. Install the two cap screws into the air filter regulator and tighten to proper torque.



3. Connect the 1/4 air line from the inertia brake to the air filter regulator at solenoid. Also connect the two (2) air lines from the slave valve to the range cylinder, LO range connects to the front of the cylinder and HI range connects to the rear (left). Connect the 1/4 air line to the TCB-6 air fitting also connect the hydraulic valve wiring harness at connector (right).

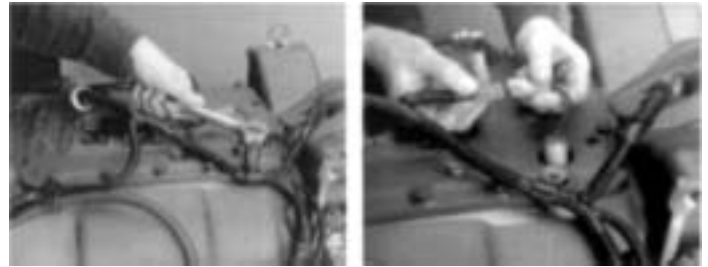

4. Connect the wiring harness clamps to the shift bar housing cap screws (left). Connect the input speed sensor and engine speed sensor at each connector as shown.



5. Install the Roadranger valve cover and slide three airlines through cover. Install the jam nut on the shift lever. Thread the Roadranger valve on shift lever and secure by tightening jam nut against valve.

# INSTALLATION - SHIFTING CONTROLS

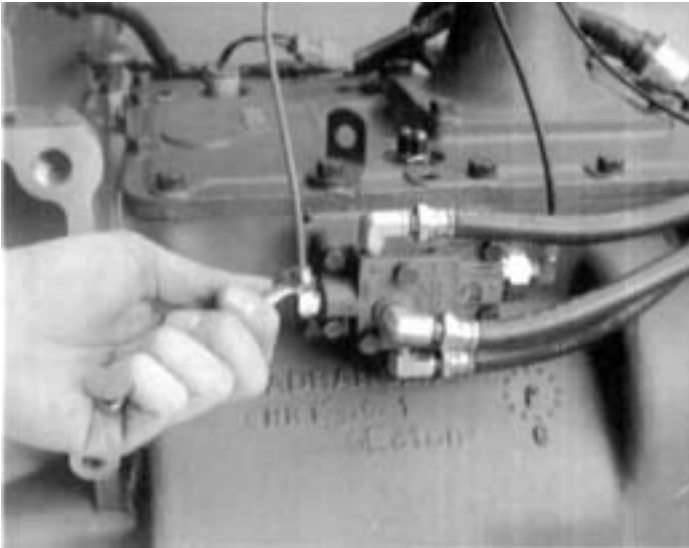

6. Connect the red air line to the "S" or Supply Port and the black air line to the "P" or End Port of the slave valve. Tighten fittings securely.

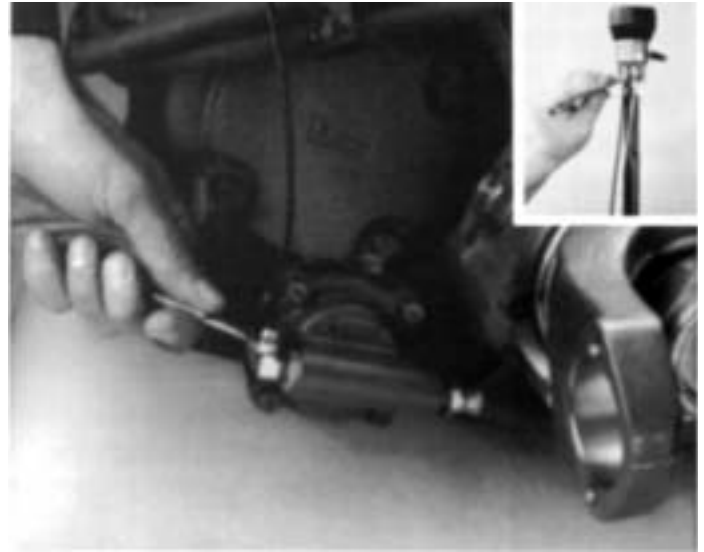

8. Connect the blue air line to the splitter cylinder cover. Tighten fittings securely.



7. Connect the red air line to the "S" or Supply Port and the black air line to the "P" Port and the blue line to the "SP" on the roadranger valve.



9. Position valve cover on Roadranger valve and secure by tightening the two mounting screws in cover.

# SHIMMING CHART

Average the feeler gauge measurement and match the measurement to the "Feeler Gauge Average Gap" in the left column. Follow the column to the right to identify the "Shim Thickness", "Part Number", and "Color Code" to be used.

FEELER GAUGE AVERAGE GAP	SHIM THICKNESS	STANDARD SHIM PART NUMBER	OIL PUMP SHIM PART NUMBER	COLOR CODE
.088-.089	.042-.043	21454	21474	BROWN
.085-.0875	.045-.046	21455	21475	TAN
.082-.0845	.048-.049	21456	21476	ORANGE
.079-.0815	.051-.052	21457	21477	YELLOW
.076-.0785	.054-.055	21458	21478	GREEN
.073-.0755	.057-.058	21459	21479	LIGHT BLUE
.070-.0725	.060-.061	21460	21480	LAVENDER
.067-.0695	.063-.064	21461	21481	WHITE
.064-.0665	.066-.067	21684	21686	BLACK
.061-.0635	.069-.070	21685	21687	SILVER
.058-.0605	.072-.074	21452+21452	21472+21472	RED + RED
.055-.0575	.075-.077	21452+21453	21472+21473	RED + PINK
.052-.0545	.078+.080	21452+21454	21472+21474	RED + BROWN
.049-.0515	.081-.083	21452+21455	21474+21475	RED + TAN
.046-.0485	.084-.086	21452+21456	21472+21476	RED + ORANGE
.043-.0455	.087-.089	21452+21457	21472+21477	RED + YELLOW
.040-.0425	.090-.092	21452+21458	21472+21478	RED + GREEN
.038-.0395	.093-.095	21452+21459	21472+21479	RED + LT. BLUE

If the transmission is equipped with an auxiliary countershaft oil pump use the fourth column to identify the oil pump shim.



Copyright Eaton Corporation, 2012. Eaton hereby grant their customers, vendors, or distributors permission to freely copy, reproduce and/or distribute this document in printed format. It may be copied only in its entirety without any changes or modifications. THIS INFORMATION IS NOT INTENDED FOR SALE OR RESALE, AND THIS NOTICE MUST REMAIN ON ALL COPIES.

**Note:** Features and specifications listed in this document are subject to change without notice and represent the maximum capabilities of the software and products with all options installed. Although every attempt has been made to ensure the accuracy of information contained within, Eaton makes no representation about the completeness, correctness or accuracy and assumes no responsibility for any errors or omissions. Features and functionality may vary depending on selected options.

**For spec'ing or service assistance, call 1-800-826-HELP (4357) or visit [www.eaton.com/roadranger](http://www.eaton.com/roadranger). In Mexico, call 001-800-826-4357.**

Roadranger: Eaton and trusted partners providing the best products and services in the industry, ensuring more time on the road.

**Eaton Corporation**

Vehicle Group  
P.O. Box 4013  
Kalamazoo, MI 49003 USA  
800-826-HELP (4357)  
[www.eaton.com/roadranger](http://www.eaton.com/roadranger)

Printed in USA

For parts or service call us  
Pro Gear & Transmission, Inc.



**1 (877) 776-4600**

**(407) 872-1901**

**parts@eprogear.com**

**906 W. Gore St.**

**Orlando, FL 32805**

