

Eaton Gen III Automated Transmissions TRSM0930 EN-US

May 2013

UltraShift®
AutoShift®
UltraShift® PLUS Linehaul Active Shifting (LAS)
UltraShift® PLUS Linehaul Small Step Efficiency (LSE)
UltraShift® PLUS Multipurpose Extreme Performance (MXP)
UltraShift® PLUS Multipurpose High Performance (MHP)
UltraShift® PLUS Vocational Active Shifting (VAS)
UltraShift® PLUS Vocational Construction Series (VCS)
UltraShift® PLUS Vocational High Performance (VHP)
UltraShift® PLUS Vocational Multipurpose Series (VMS)
UltraShift® PLUS Vocational Extreme Performance (VXP)
UltraShift® PLUS Passenger Vehicle (PV)



Powering Business Worldwide

BACKED BY
Roadranger
SUPPORT

Model:

F-5405B-DM3	RTO-14910B-DM3	FO-18E310C-LAS	FO-14E309ALL-VMS
F-6405B-DM3	RTO-14910C-AS3	FOM-14E310C-LAS	FO-16E309ALL-VMS
F-14E316B-LSE	RTO-16910B-AS3	FOM-15E310C-LAS	FO-17E309ALL-VMS
F-15E316B-LSE	RTO-16910B-DM3	FOM-16E310C-LAS	FO-14E313B-MHP
F-17E316B-LSE	RTO-16910C-AS3	FM-14E310B-LAS	FO-16E313B-MHP
FM-15E316B-LSE	RTO-18910B-AS3	FM-15E310B-LAS	FO-18E313B-MHP
FM-14D310B-LST	FO-10E310C-VAS	EO-11E406B-PV	FO-20E313B-MHP
FM-15D310B-LST	FO-12E310C-VAS	FOM-15E310C-VAS	FO-14E318B-MXP
FO-16D313E-LEP	FO-14E310C-VAS	FOM-16E310C-VAS	FO-16E318B-MXP
FO-5406B-DM3	FO-16E310C-VAS	FO-10E308LL-VCS	FO-18E318B-MXP
FO-6406A-AW3	FOM-14E310C-VAS	FO-11E308LL-VCS	FO-20E318B-MXP
FO-6406B-AW3	F-5505B-DM3	FO-12E308LL-VCS	FO-22E318B-MXP
FO-8406A-AW3	F-6505B-DM3	FO-14E308LL-VCS	FO-14E318B-VXP
FOM-16D313E-LEP	RTLO-18918A-AS3	FO-16E308LL-VCS	FO-16E318B-VXP
RTLO-14918A-AS3	RTLO-20918A-AS3	FO-17E308LL-VCS	FO-18E318B-VXP
RTLO-16913L-DM3	RTLO-22918A-AS3	FO-16E313A-VHP	FO-20E318B-VXP
RTLO-16918A-AS3	RTLLOM-16913L-DM3	FO-18E313A-VHP	FO-22E318B-VXP
RTO-10910B-DM3	RTO-10910B-AS3	FO-20E313A-VHP	FO-22E318B-VXP
RTO-12910B-AS3	RTOM-16910B-DM3	FO-10E309ALL-VMS	EO-11E406B-PVER
RTO-12910B-DM3	FO-14E310C-LAS	FO-11E309ALL-VMS	EO-11E406B-PVHR
RTO-14910B-AS3	FO-16E310C-LAS	FO-12E309ALL-VMS	EO-11E406B-PV

Table of Contents

General Information

Warnings & Cautions	1
How to use this Manual	2
Transmission Overview	3
Serial Tag Information and Model Nomenclature	15
Clutch Greasing Guidelines	19
Grease Interval Count Reset	19
ServiceRanger Procedure	20
Operator Triggered Procedure	22

Service Procedure

Thread-In ECA Speed Sensor	23
Electronic Clutch Actuator (ECA)	27
Low Capacity Inertia Brake	31
Release Yoke and Cross-shaft(s)	35
Cobra Lever	41
Shift Control	45
Medium-Duty Transmission Harness	49
Heavy-Duty Transmission Harness	53
Medium-Duty Transmission Electronic Control Unit (TE-CU)	57
Heavy-Duty Transmission Electronic Control Unit (TECU) 61	61
Electric Shifter	65
Medium-Duty Inertia Brake	69
Air Filter Regulator	75
Heavy-Duty Inertia Brake	79
Combination Valves (Range and Deep Reduction)	83
Range Valve	87
Splitter Valve	91
Directional Output Shaft Speed Sensor	95
Park Actuator Assembly	99
Park Pawl Position Sensor	103
Medium-Duty Output Shaft Speed Sensor	107
Heavy-Duty Output Shaft Speed Sensor	111
Main Shaft Speed Sensor	115
Medium-Duty Input Shaft Speed Sensor	119
Heavy-Duty Input Shaft Speed Sensor	123
Rail Select Sensor	127
Gear Select Sensor	131
Lubricant Filter (AW3 Models Only)	135

Appendix

Operation and Basic Troubleshooting	139
Inspection Procedures	140
Lubrication Specifications	141
UltraShift DM3 and AutoShift AS3	141
Buy From a Reputable Dealer	141
Transmission Operating Angles	141
Operating Temperatures with Oil Coolers	141
UltraShift™ ASW Models	141
Buy From a Reputable Dealer	142
Synthetic Dextron III ATF	142
CD-50	142
Maintenance and Lubricant Change Intervals	142
Checking Wet Clutch Lubricant	142
Proper Wet Clutch Lubricant Level	142
Checking Gearbox Lubricant	142
Cooler	142
Proper Gearbox Lubricant Level	142
Drain the Transmission Gearbox and Wet Clutch Housing	143
Change Wet Clutch Filters	143
Fill the Transmission	143
Clutch Calibration	143
Maintenance and Lubricant Change Intervals	144
Checking Wet Clutch Lubricant	144
Proper Wet Clutch Lubricant Level	144
Checking Gearbox Lubricant	144
Cooler	144
Proper Gearbox Lubricant Level	144
Drain the Transmission Gearbox and Wet Clutch Housing	145
Change Wet Clutch Filters	145
Fill the Transmission	145
Clutch Calibration	145
Tool Specifications	146
General Tools	146
Torque Specifications	147
Torque Overview	149
Grade Sensor Calibration	152
ServiceRanger Procedure	152
Operator-Triggered Procedure	154

Warnings & Cautions

 **Warning:** Follow the specified procedures in the indicated order to avoid personal injury.

Note: Additional relevant information not covered in the service procedure.

 **Warning:** Before starting a vehicle:

- Ensure adequate fuel level.
- Sit in the driver's seat.
- Place shift lever in neutral.
- Set the parking brake.

 **Warning:** Before working on a vehicle or leaving the cab with engine running:

- Ensure ignition is off while hands are within the clutch housing area.
- Place shift lever in neutral.
- Set the parking brake.
- Block the wheels.

 **Warning:** When parking the vehicle or leaving the cab:

- Place shift lever in neutral.
- Set the parking brake.

 **Caution:** Follow the specified procedures in the indicated order to avoid equipment malfunction or damage.

 **Caution:** Do not release the parking brake or attempt to select a gear until the air pressure is at the correct level.

 **Caution:** To avoid damage to the transmission during towing:

- Place shift lever in neutral.
- Lift the drive wheels off of the ground or disconnect the driveline.

 **Caution:** Do not operate the vehicle if alternator lamp is lit or if gauges indicate low voltage.

For parts or service call us
Pro Gear & Transmission, Inc.



1 (877) 776-4600

(407) 872-1901

parts@eprogear.com

906 W. Gore St.

Orlando, FL 32805



How to use this Manual

This publication is divided into three sections General Information, Service Repair Procedures and the Appendix.

General Information

This section contains the basic chapters like “Transmission Overview,” “How to Use This Manual” and “Serial Tag and Model Nomenclature.”

Service Repair Procedures

A “Components Identification” diagram is included at the beginning of each procedure for disassembly, assembly, removal and installation. Below the “Components Identification” diagram is a numerical listing for each part with the part name.

Appendix

This section contains information like: “Operation,” “Lubrication Specifications,” “Inspection” (in base box manuals), “Powerflow” (in base box manuals), “Air System Operation” and “Troubleshooting” (in base box manuals), “Basic Troubleshooting” (in base box manuals), “Tool Specifications,” “Torque Specifications,” and the “Torque Overview.”

The service procedures in this manual are for transmission automation components only. To find the information you need, simply locate the procedure in the “Table of Contents,” turn to the page specified and follow the procedure. If you are unsure of a components’ name, you can reference the “Transmission Overview” pages.

To service the mechanical portion of the transmission system, refer to the specific transmission service manual.

Transmission Overview

Heavy-Duty 8LL / VCS & 9ALL / VMS

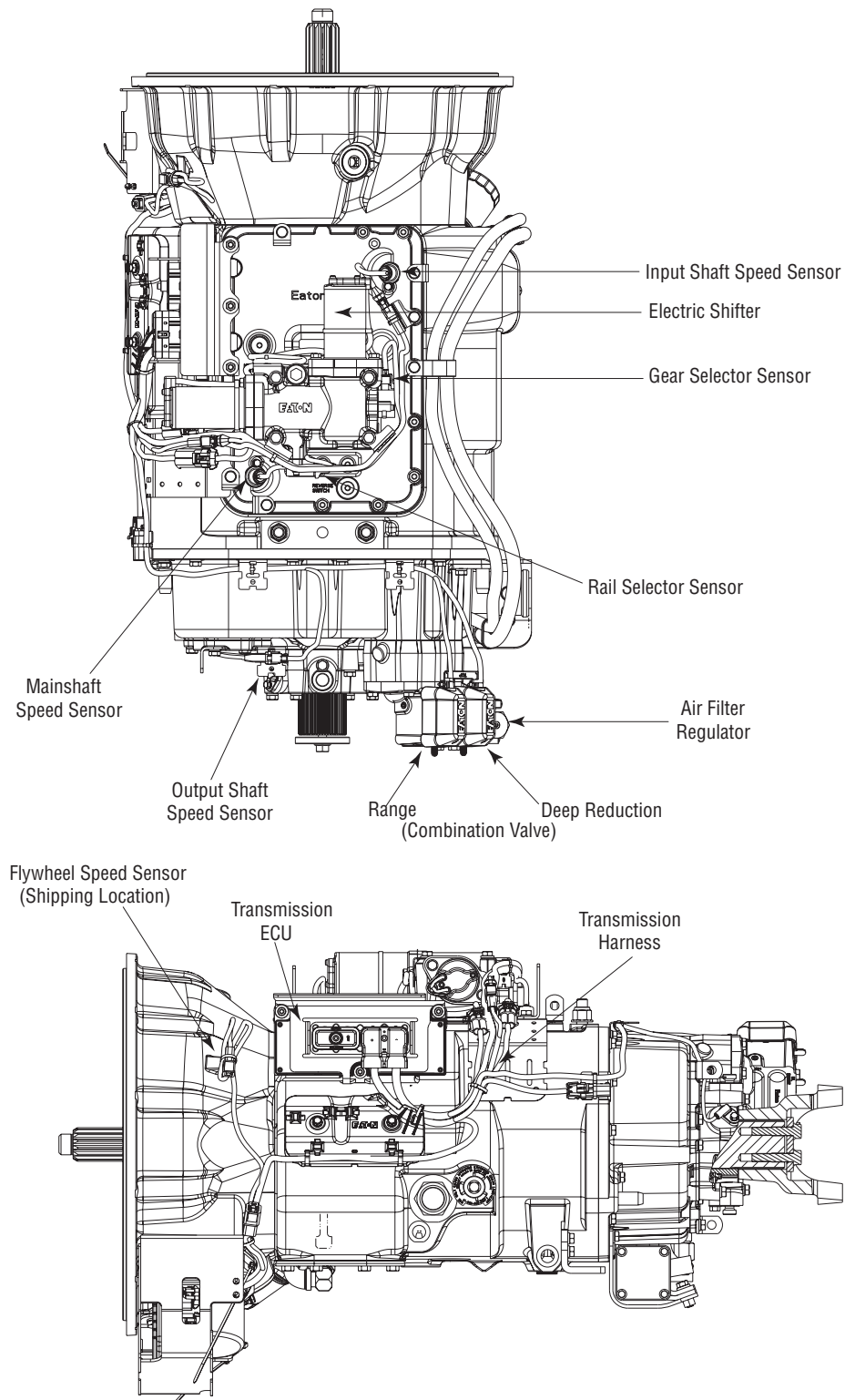

Heavy-Duty 8LL / VCS & 9ALL / VMS

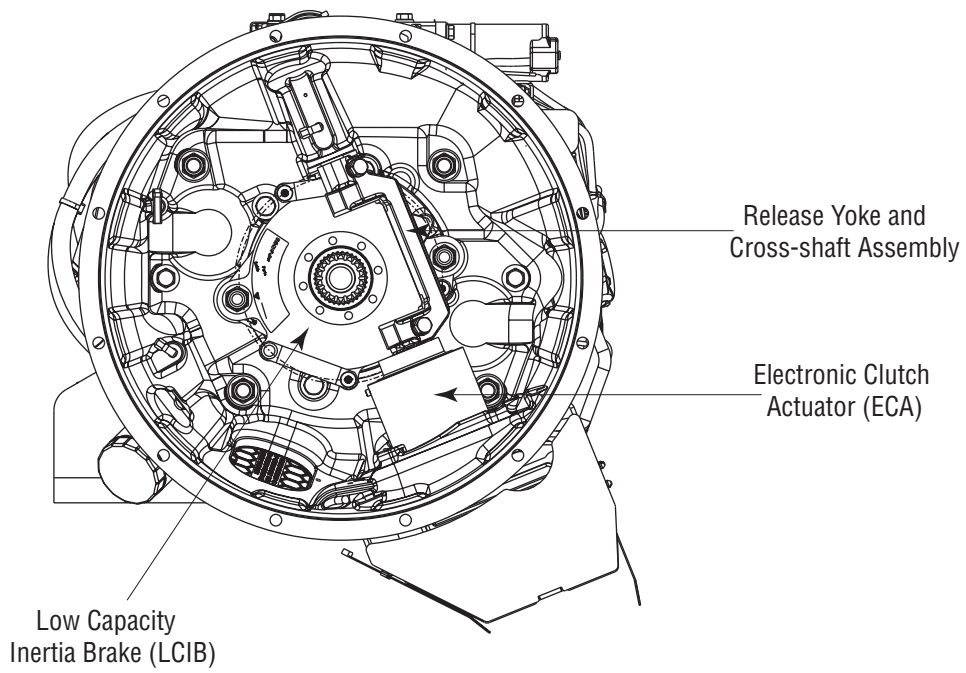

Heavy-Duty 10-Speed LAS/VAS

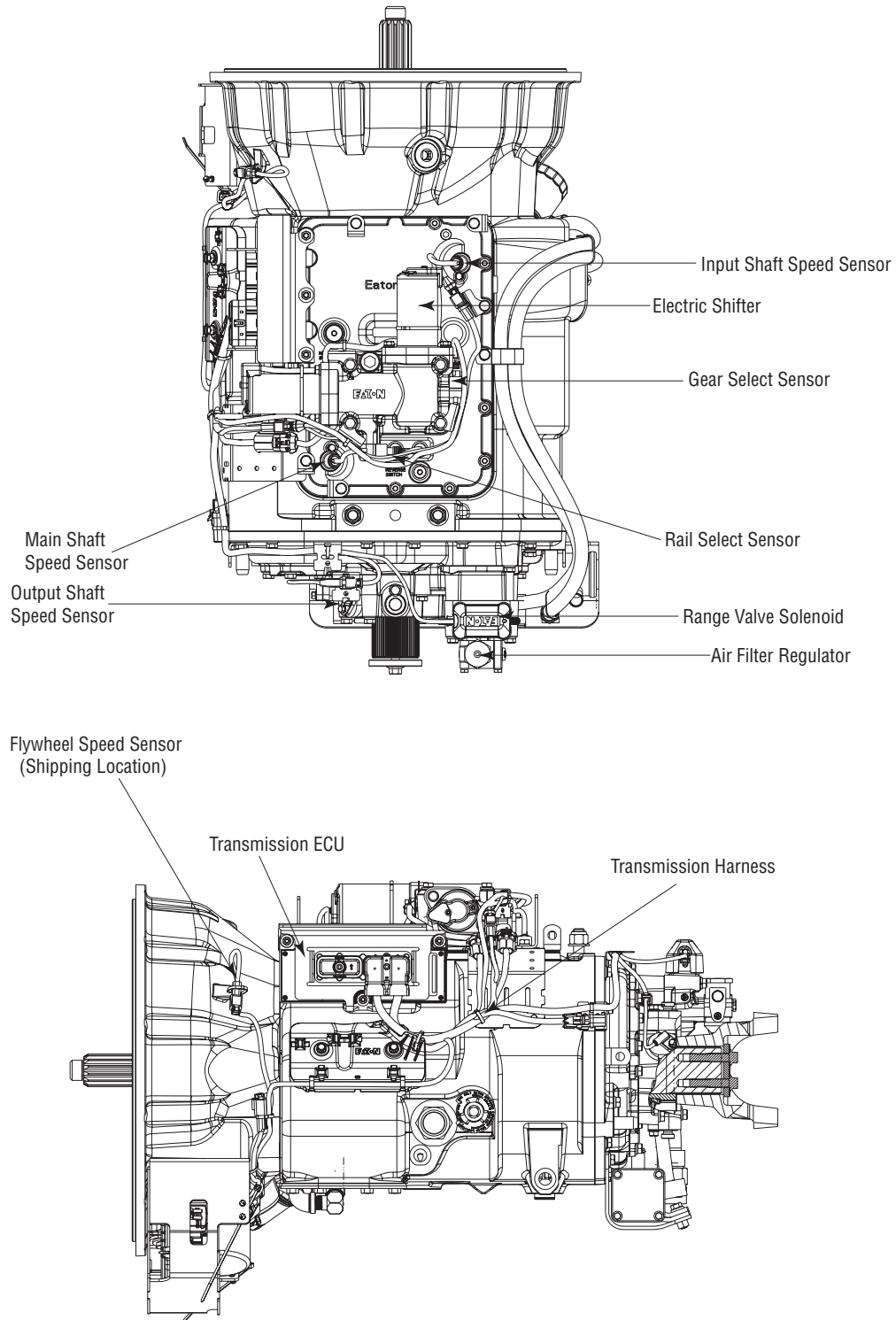

Heavy-Duty 10-Speed LAS/VAS

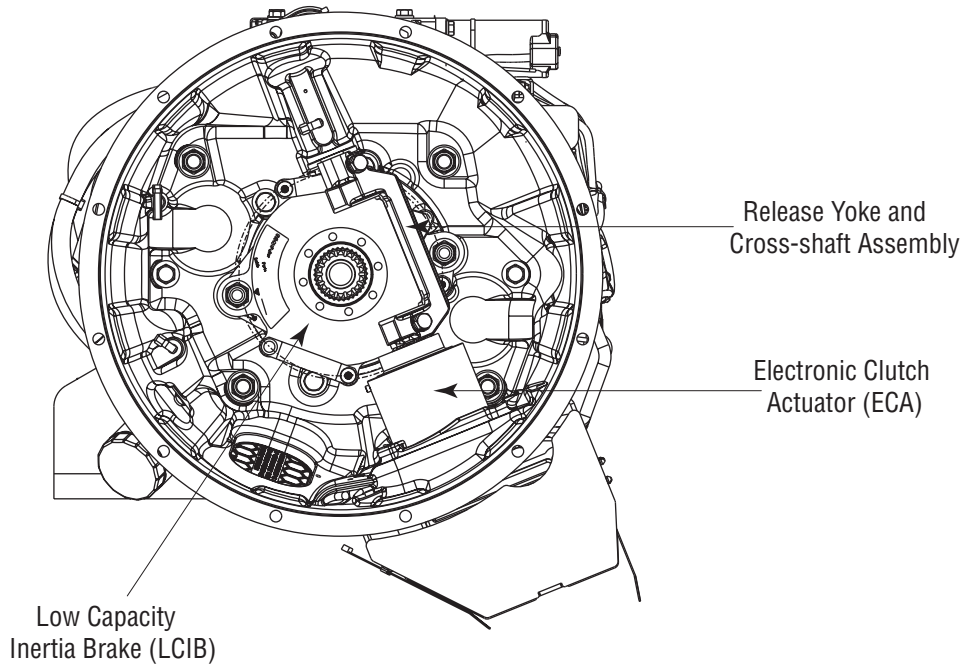

Heavy-Duty 13-Speed MHP/VHP, 16-Speed LSE & 18-Speed VXP/MXP

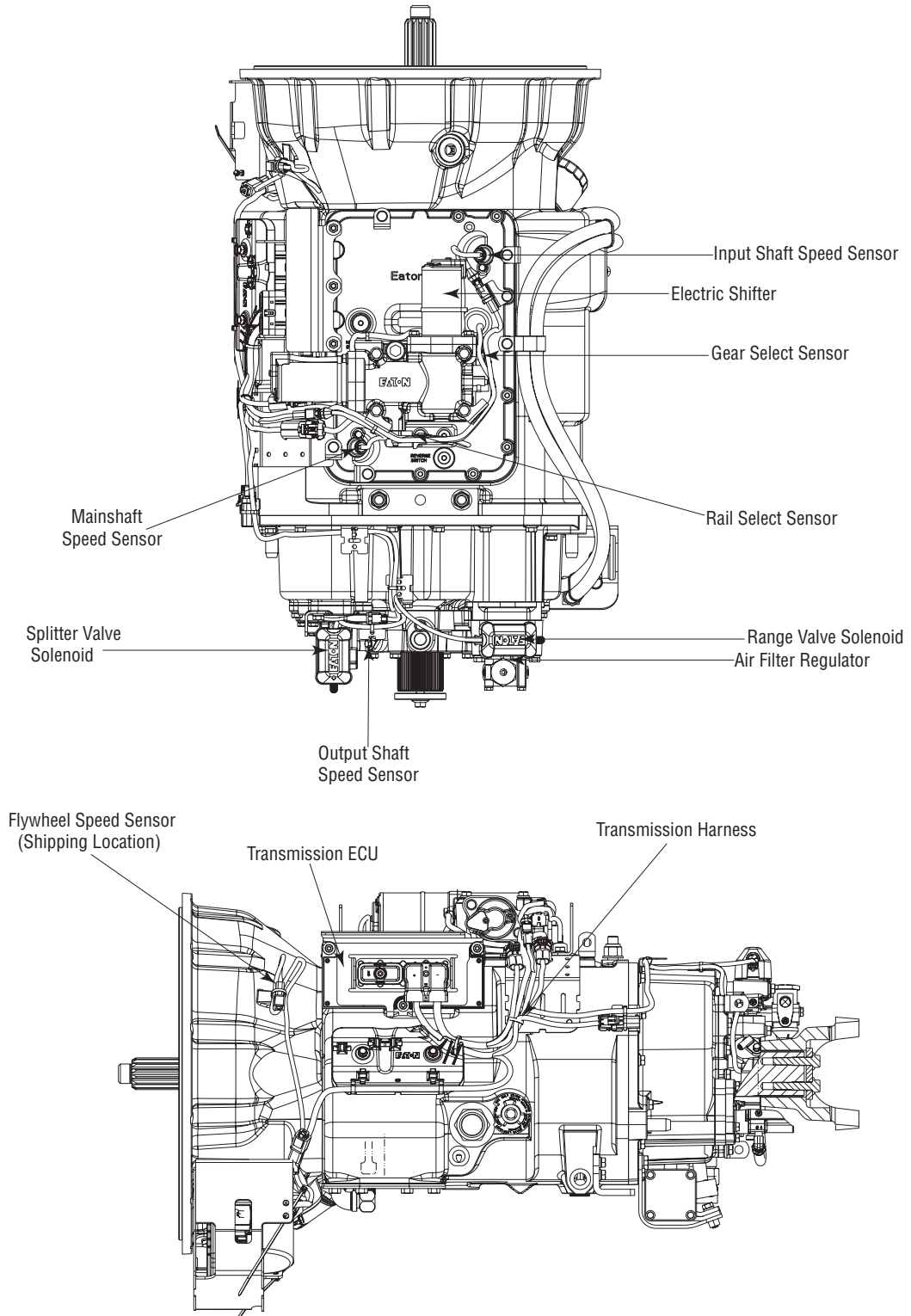

**Heavy-Duty 13-Speed MHP/VHP, 16-Speed LSE
& 18-Speed VXP/MXP**

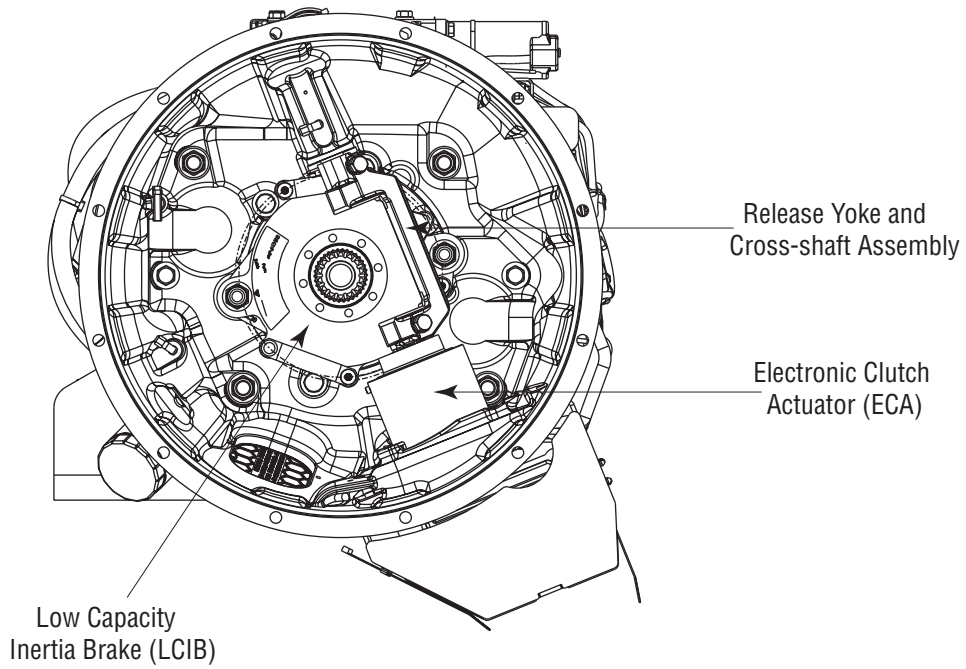

Heavy-Duty 13-Speed DM3 & 18-Speed AS3

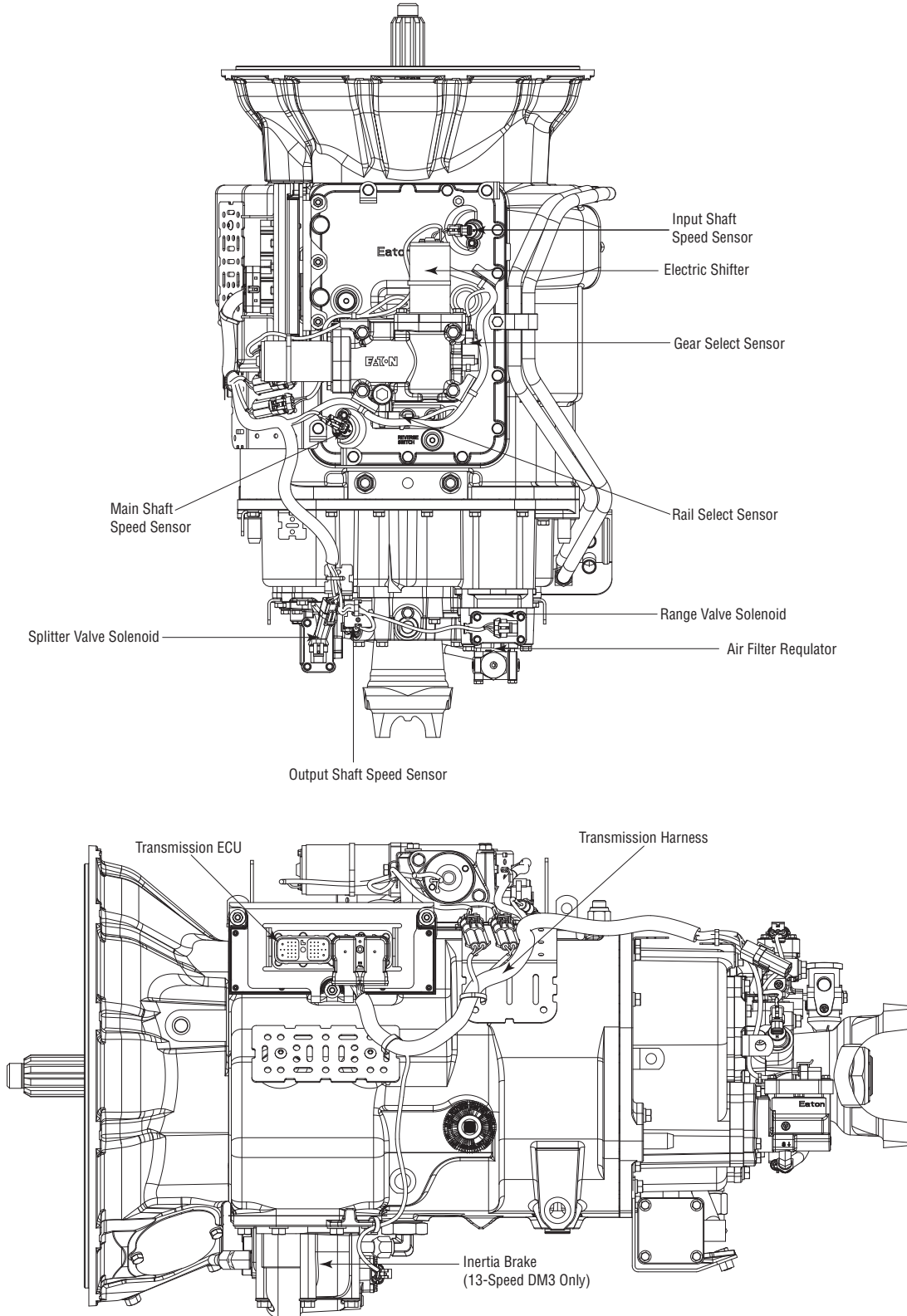

Heavy-Duty 10-Speed AS3 & DM3

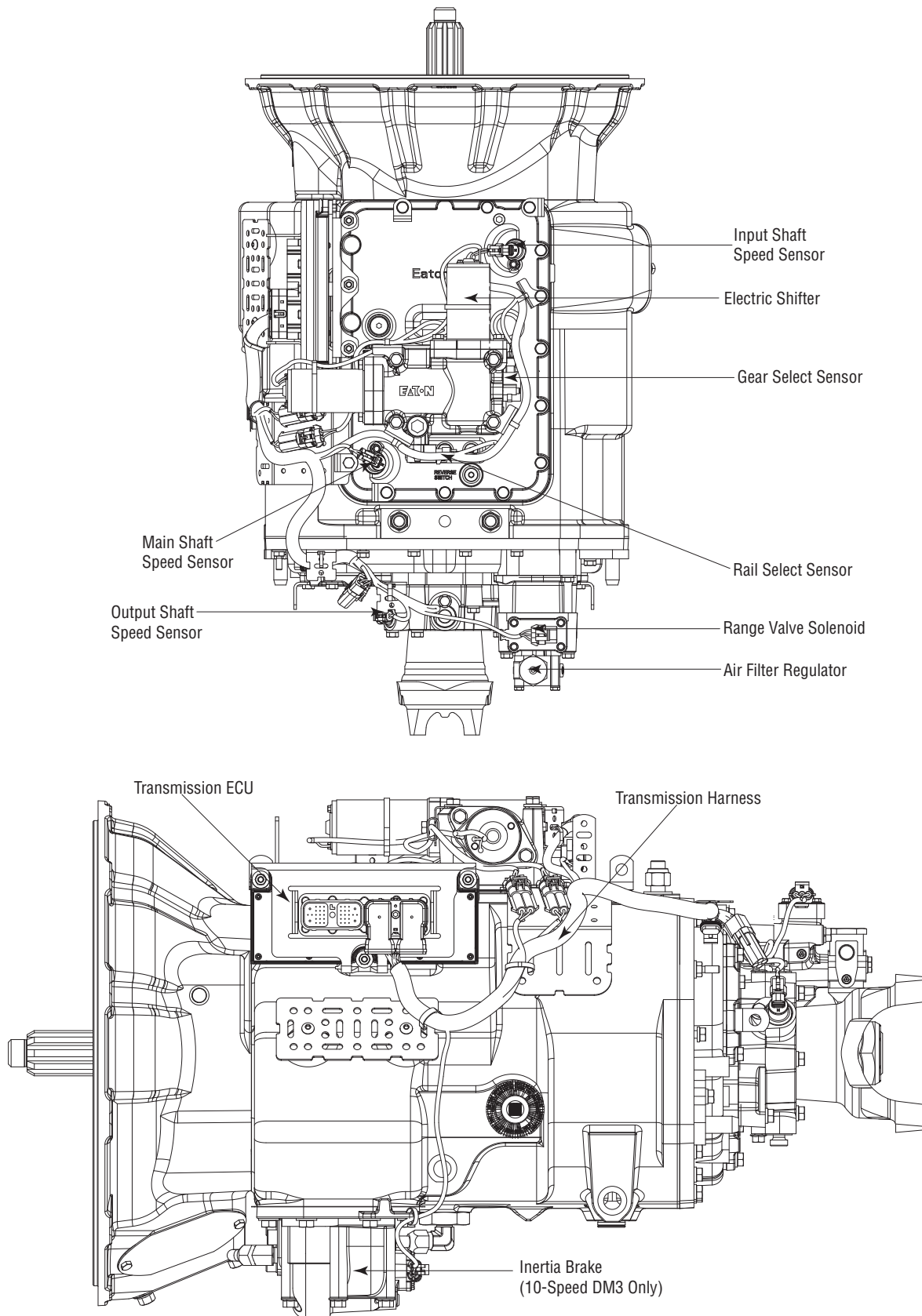

Medium-Duty 6 & 5-Speed DM3

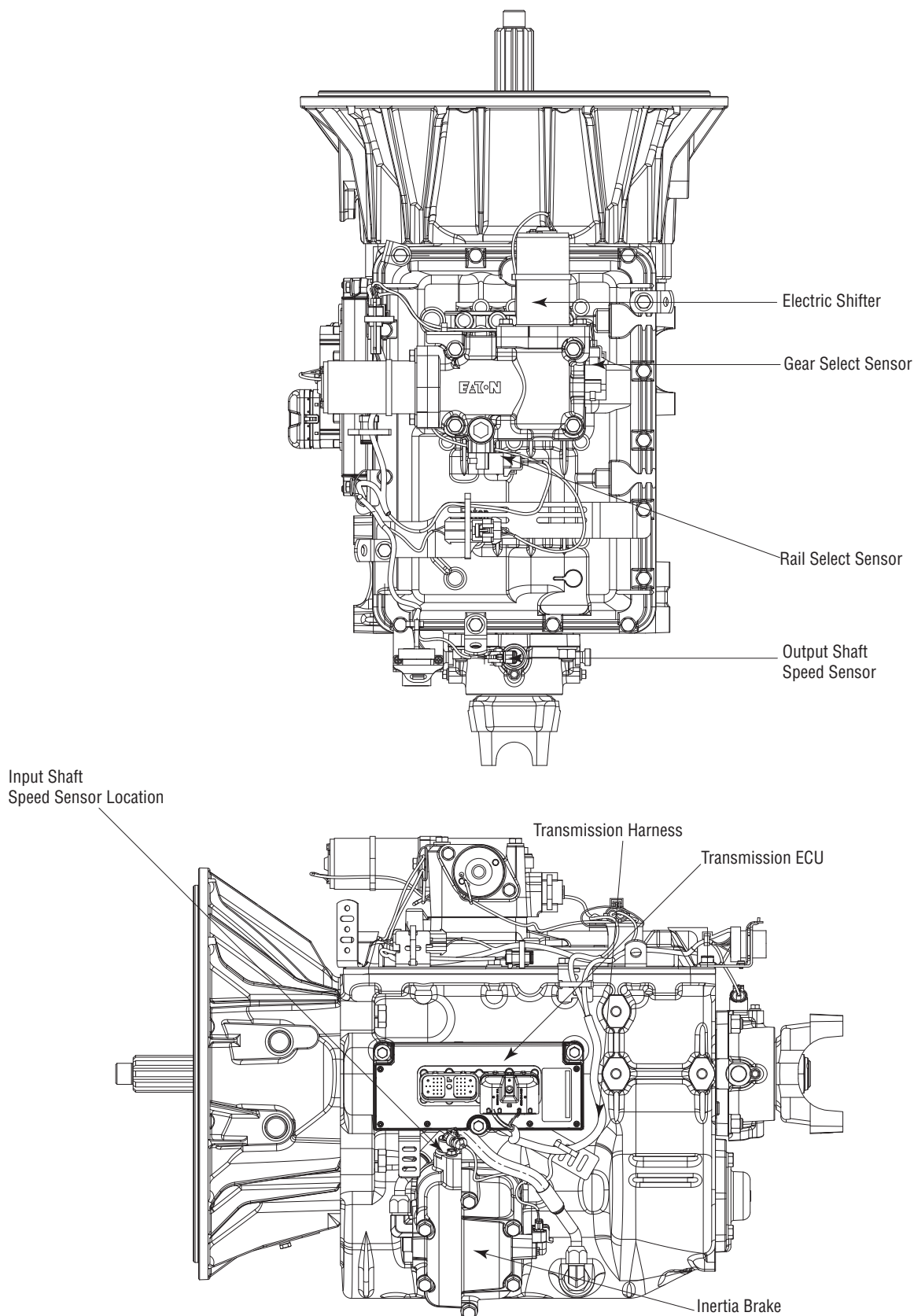

Medium-Duty 6-Speed AW3

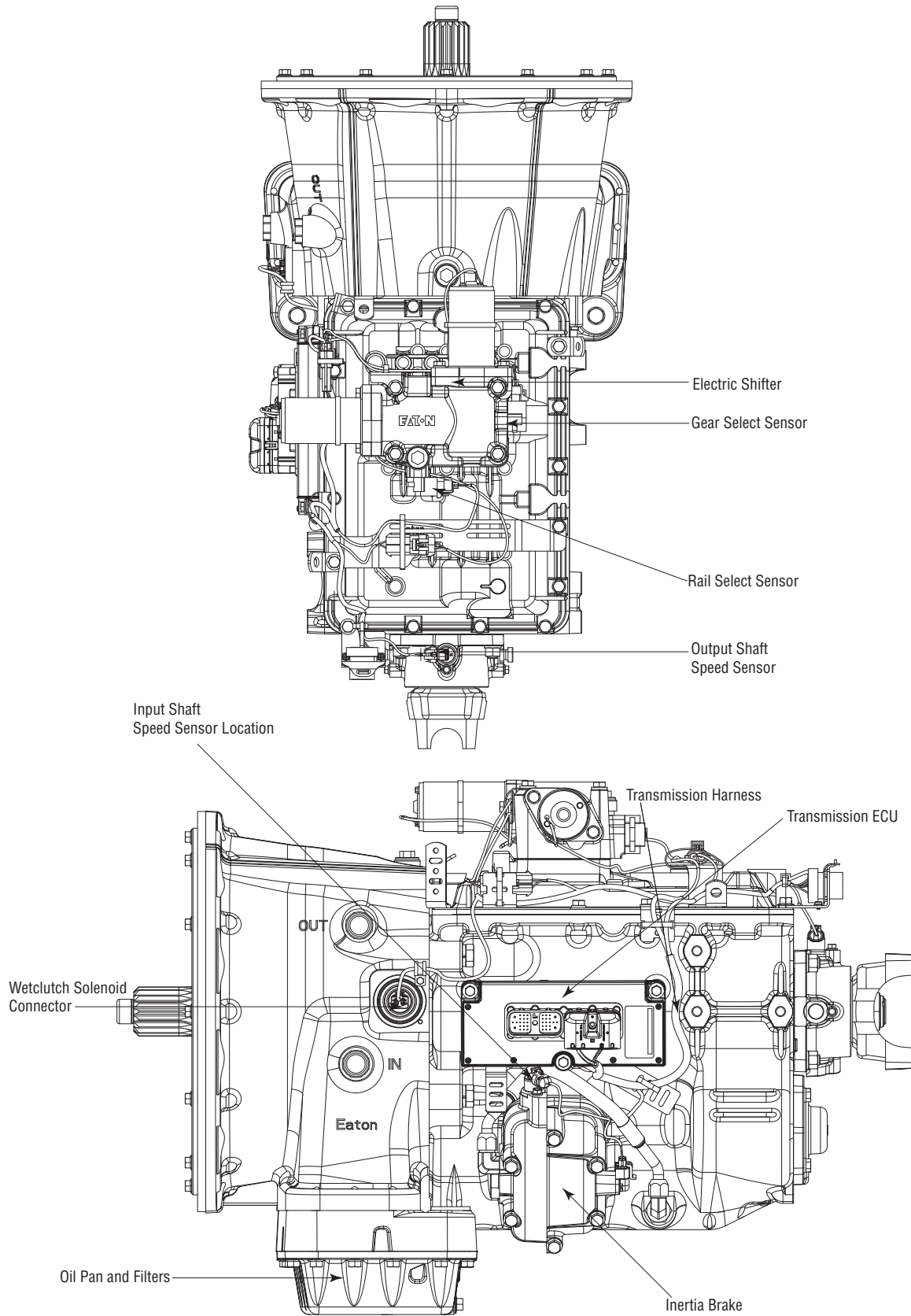

Medium-Duty 6-Speed PV

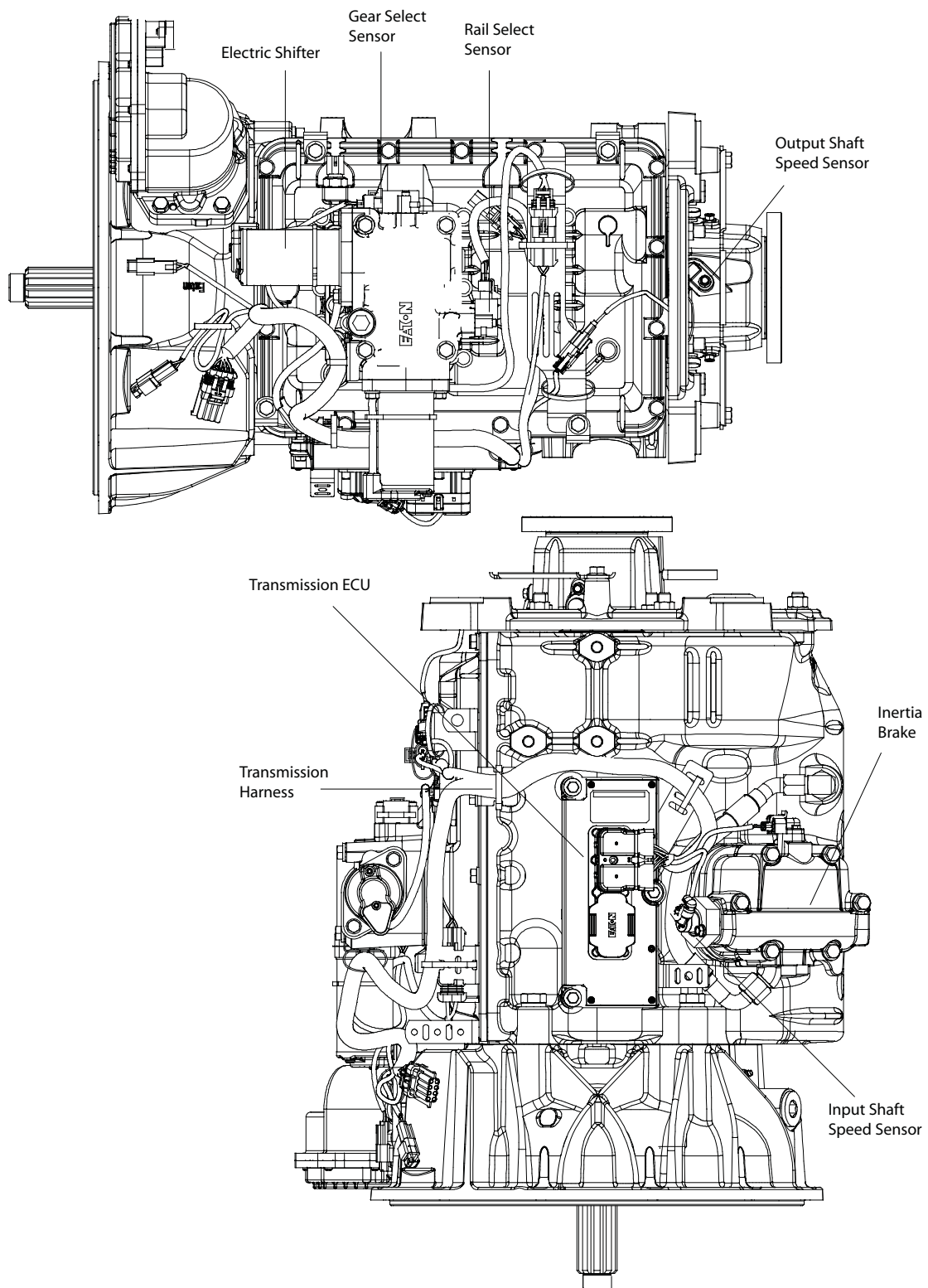

Medium-Duty 6-Speed PV

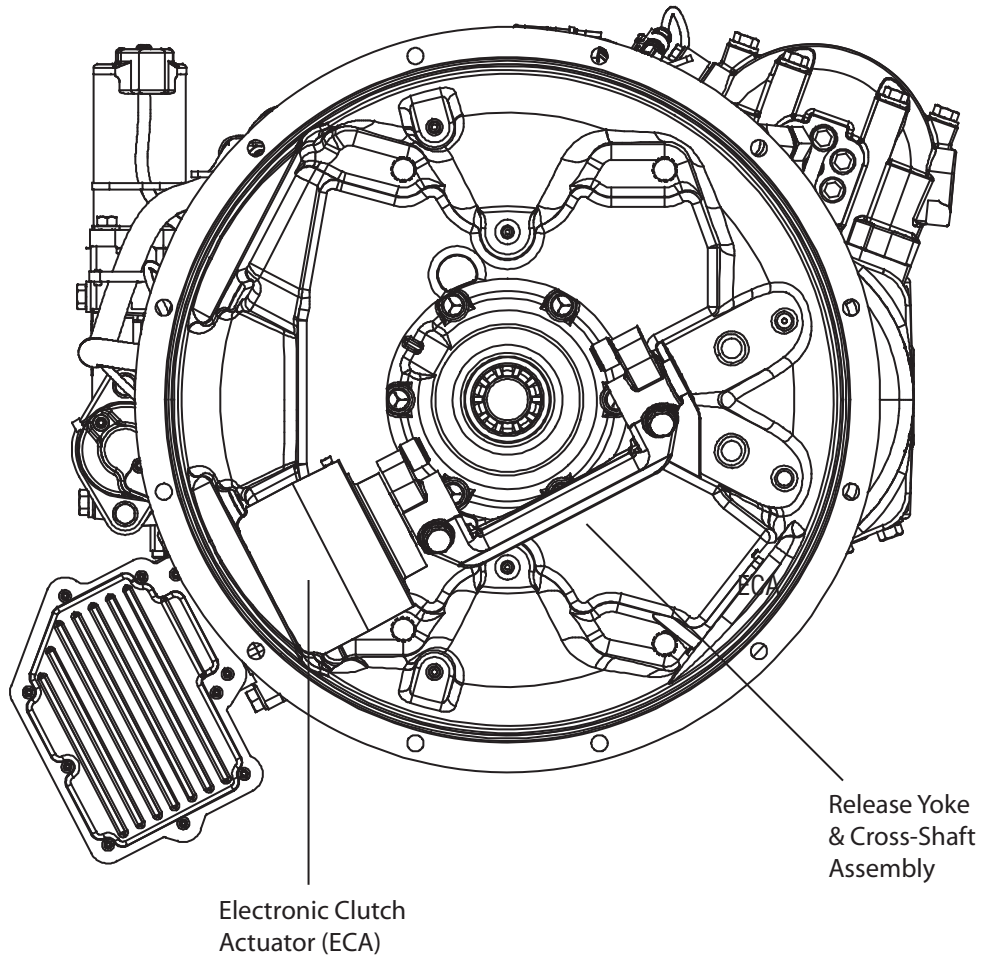

Serial Tag Information and Model Nomenclature

Transmission model designation and other transmission identification information are stamped on the serial tag. To identify the transmission model and serial number, locate the tag on the transmission and then locate the numbers as shown. The figure below shows the tag location for these transmissions.

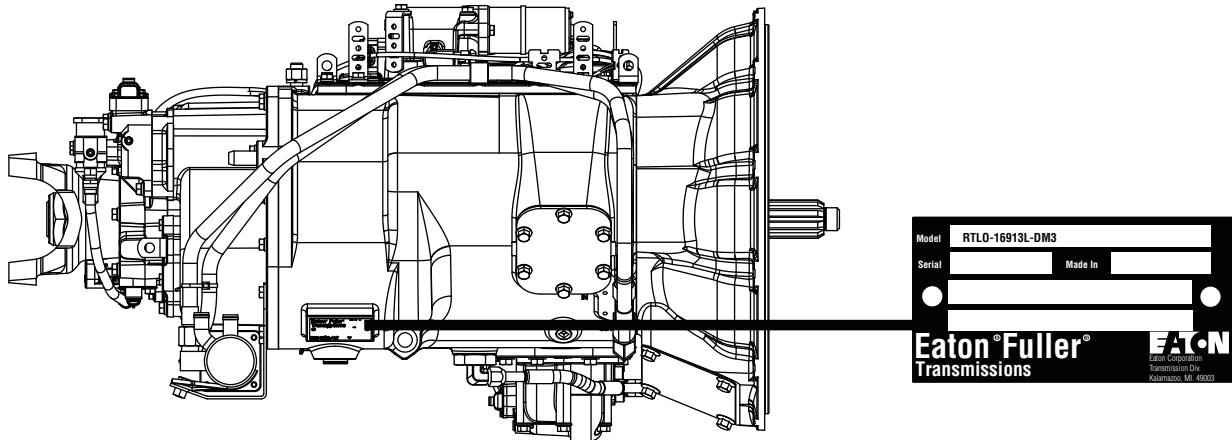

When calling for service assistance or parts, have the model and serial numbers handy.

Do not remove or destroy the transmission identification tag!

Serial Number

The serial number is the sequential identification number of the transmission. Before calling for service assistance, write the number down as it may be needed.

Bill of Material or Customer Number

This number may be located below the model and serial numbers. It is a reference number used by Eaton®.

Model Number

The model number gives basic information about the transmission and is explained below. Use this number when calling for service assistance or replacement parts.

Transmission Tag

5-Speed

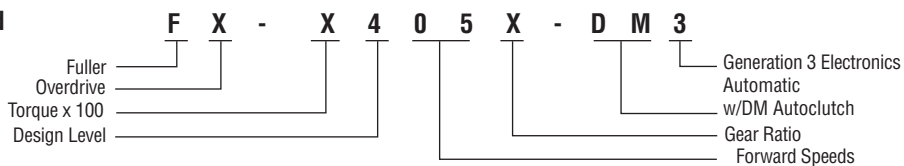

6-Speed

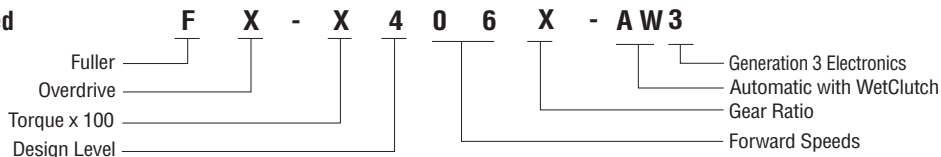

6-Speed

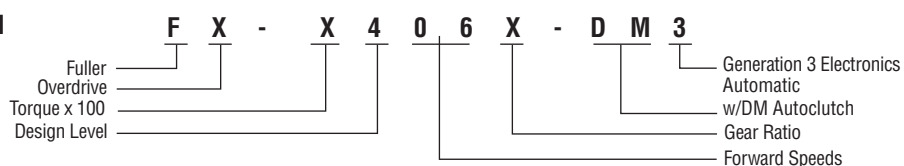

10-Speed

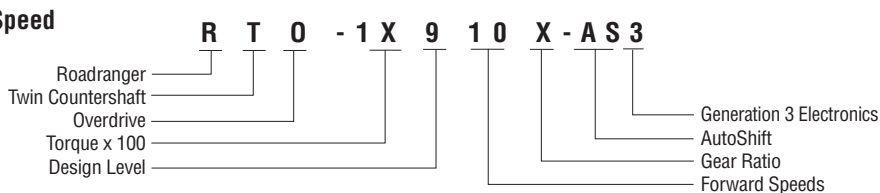

10-Speed

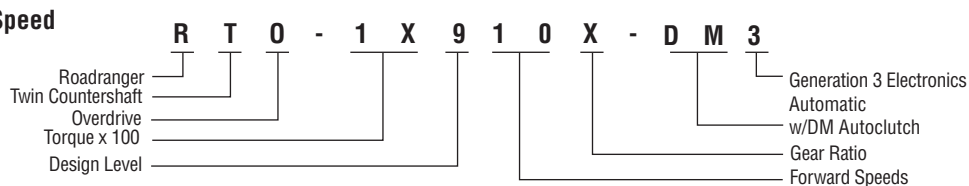

13-Speed

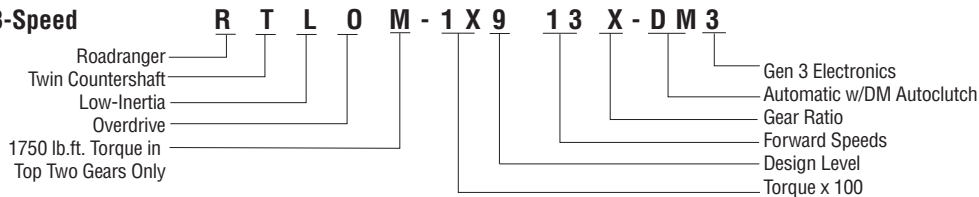

18-Speed

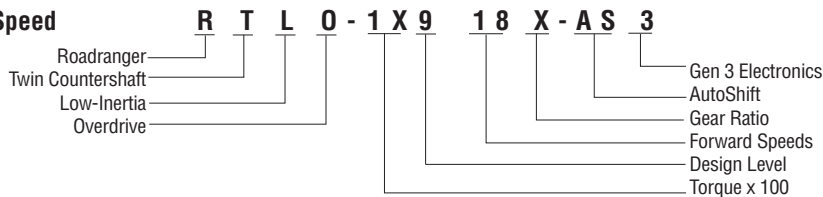

6-Speed

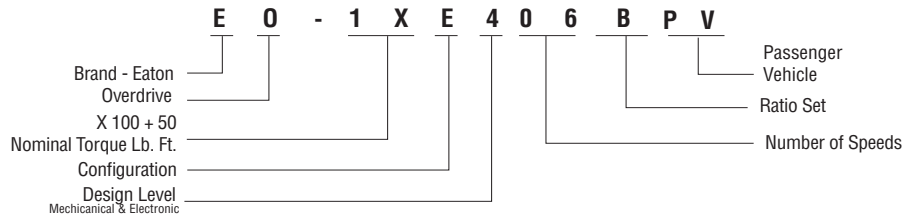

10-Speed

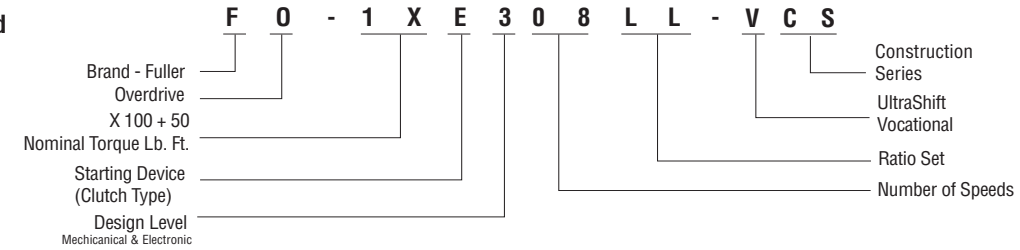

10-Speed

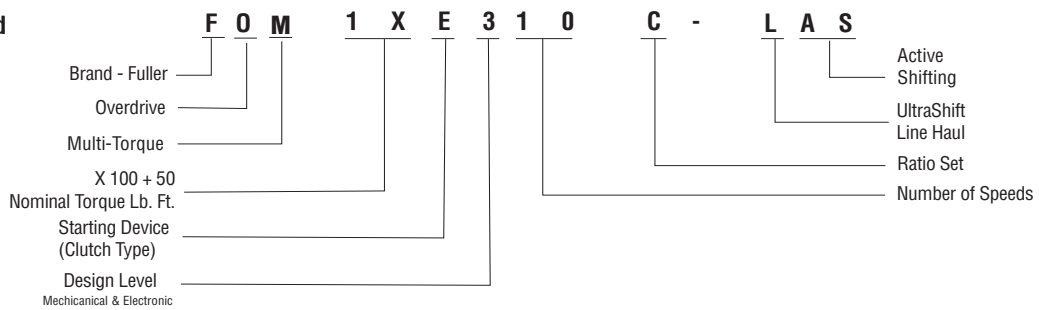

10-Speed

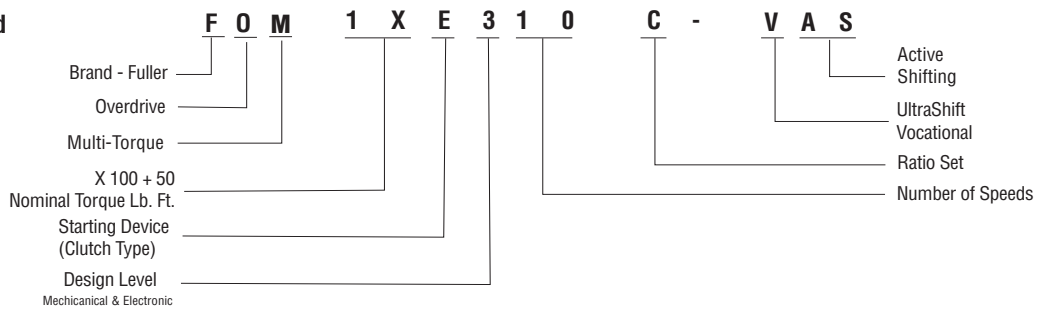

11-Speed

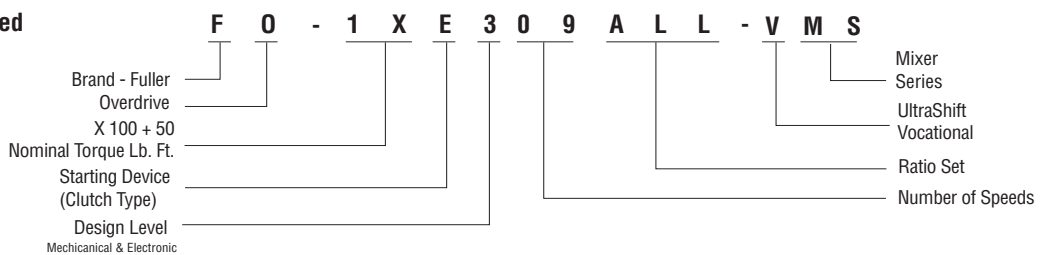

13-Speed

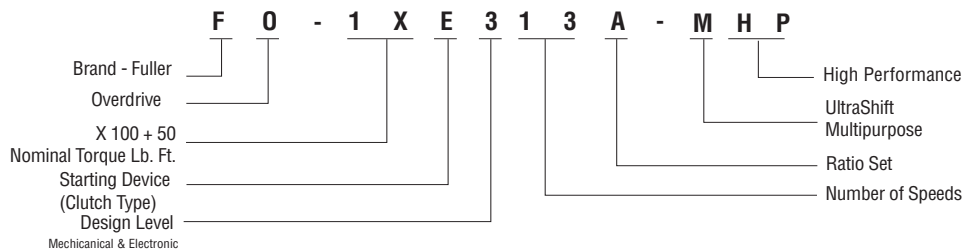

13-Speed

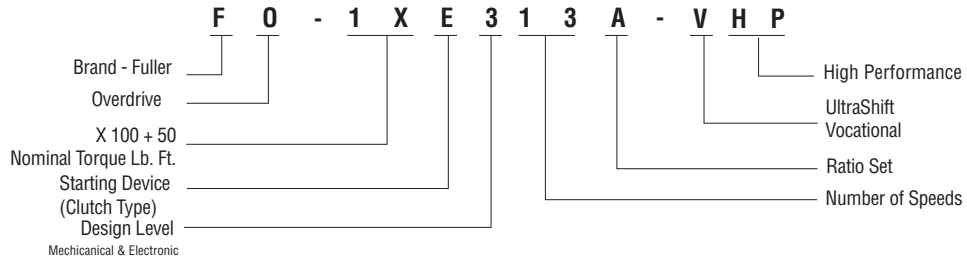

16-Speed

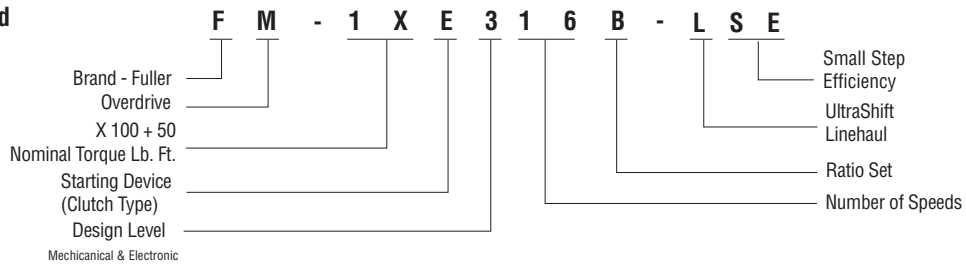

18-Speed

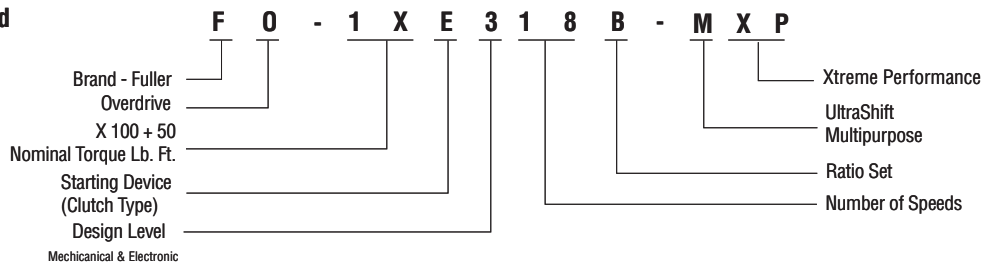

Clutch Greasing Guidelines



Caution: It is highly important to follow proper clutch lube intervals as specified in *Lubrication Manual* TCMT0021. Failure to do so may result in clutch failure and unnecessary repairs.

The heavy-duty ECA clutch housing has 2 grease fittings on the lower right side. The upper port is marked “CS” for the upper cross-shaft assembly, while the lower port is marked “RB” for the release bearing.



For more detailed cross-shaft greasing information refer to the Release Yoke and Cross-shaft Installation section of this manual. Refer to *Clutch Service Manual* CLSM0200, for release bearing greasing information.

Grease Interval Count Reset

The Heavy-Duty UltraShift *PLUS* has an optional prognostic feature that notifies the operator when the Clutch Release Bearing needs greasing. This feature can be enabled or disabled via ServiceRanger.

At the appropriate grease interval and shortly after each engine start, “GI” will momentarily appear in the gear display, along with an audible tone. This will continue to occur at each engine start until clutch service has been completed.

Note: “GI” stands for grease interval and may be misread as “G1” on gear display.

The operator can choose to follow this automated lube schedule or the published lube guidelines in the *Lubrication Manual* TCMT0021. When enabled, it is highly important to reset the grease interval count every time the Release Bearing is greased.

The grease interval count can be reset via ServiceRanger or Operator-Triggered Special Function.

ServiceRanger Procedure

Operator Triggered Procedure

- 1** From the off position, turn ignition to on without cranking the engine.



- 2** Select low mode on the shift device.

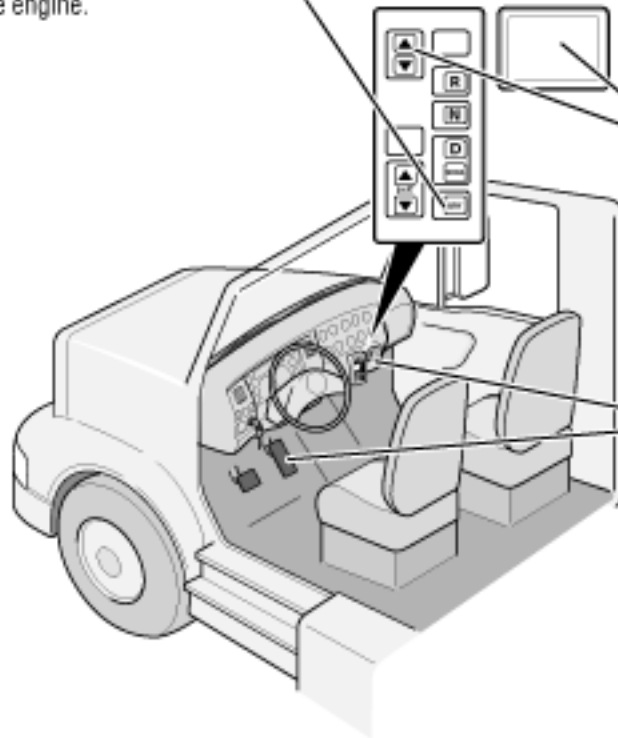

- 3** Press the manual up-shift button until the gear display shows "3".



- 4** Press Accelerator to the floor. Gear display will show a down arrow.



- 5** Release the accelerator. Gear display will show a "0".



- 6** Select neutral and turn ignition to off in order to save the reset.

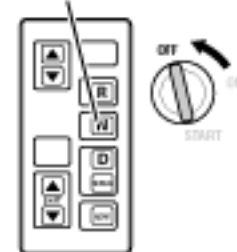

Thread-In ECA Speed Sensor

Special Instructions

None

Special Tools

Basic hand tools

Component Identification

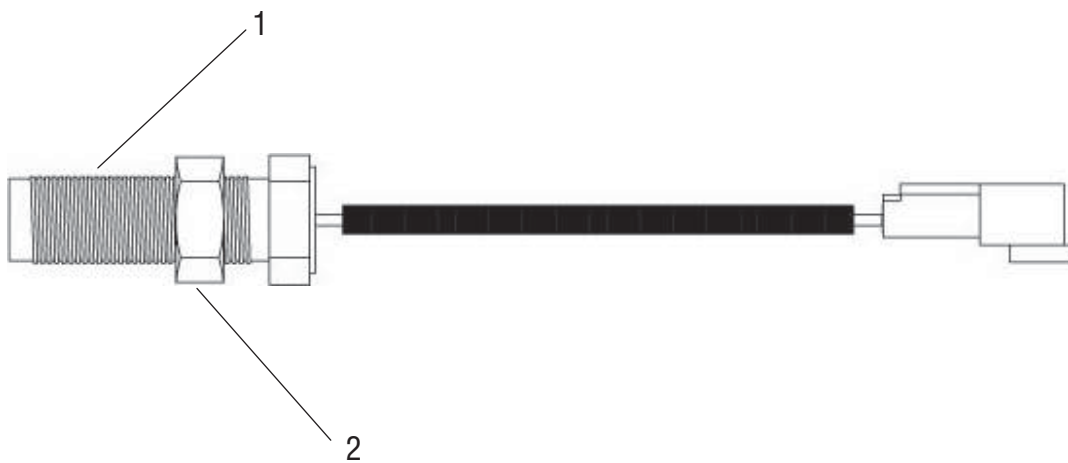

- 1. Sensor
- 2. Jam Nut

Procedure - Removal

1. Disconnect ECA Speed Sensor Connector.



2. Loosen jam nut on ECA.



3. Rotate sensor counterclockwise to remove it.



Procedure - Installation

1. Thread Speed Sensor into the Engine Bell Housing until it touches the flywheel.



2. After the sensor touches the flywheel, rotate it counterclockwise 1/2 to 1 full turn.



3. Hold the sensor in place and tighten the 3/4"-16 jam nut to 15 lb-ft. (20.3 Nm).



4. Apply included material to low-voltage 4-way harness connector terminals.

Note: Apply just enough material to cover the end of the terminal.

Note: Use only Eaton lubricant part number 5564527. (Nye Lubricants NYOGEL 760G. For MSDS safety or other information see www.nyelubricants.com).

5. Connect Engine Speed Sensor Connector to the mating connector on the transmission and fasten harness, if needed.

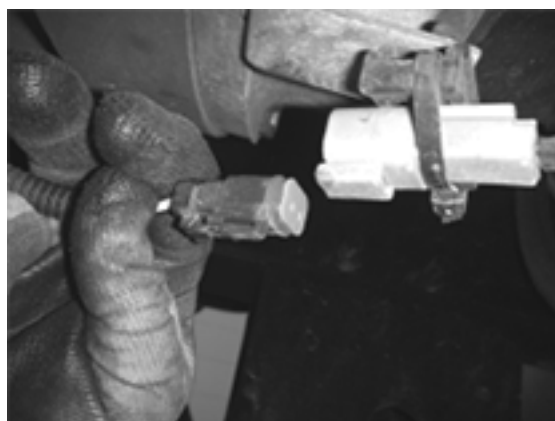

Electronic Clutch Actuator (ECA)

Special Instructions

If vehicle is equipped with an 8-bolt PTO, removal may be required prior to removing the ECA. Follow PTO manufacturer's guidelines for removal.

Special Tools

Basic hand tools

Component Identification

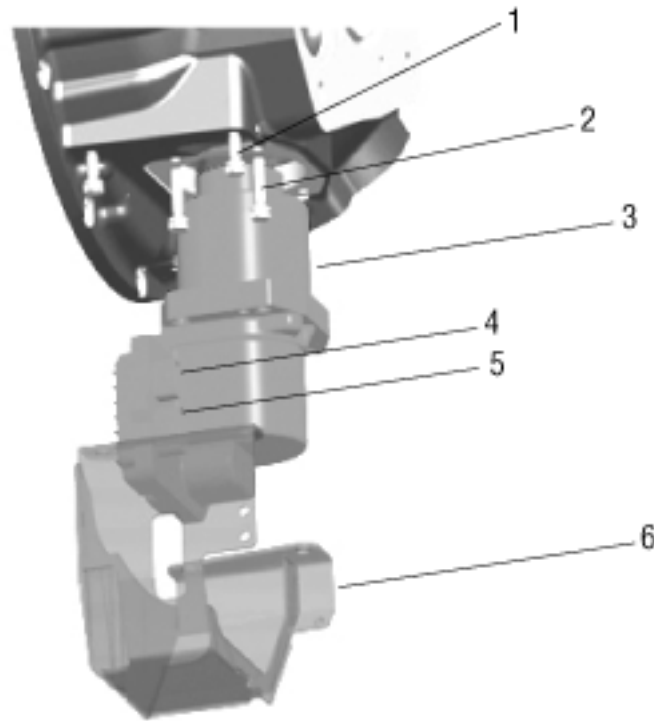

1. Bracket Cap Screw
2. ECA Cap Screw
3. ECA
4. 8-Way Connector
5. 3-Way Connector
6. ECA Shield (Optional)

Procedure - Removal



Warning: Ensure the Hand Hole Cover is closed when removing the ECA.

1. Disconnect the negative battery cable.
2. Disconnect the 8-way and 3-way connectors from the ECA.

Note: Some models do not use a shield.

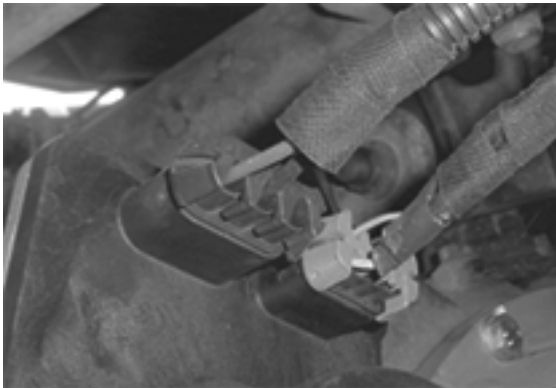

3. Remove the 4 cap screws from the ECA shield and remove shield.

Note: Medium-duty models are mounted with 3 cap screws and 1 lock nut.

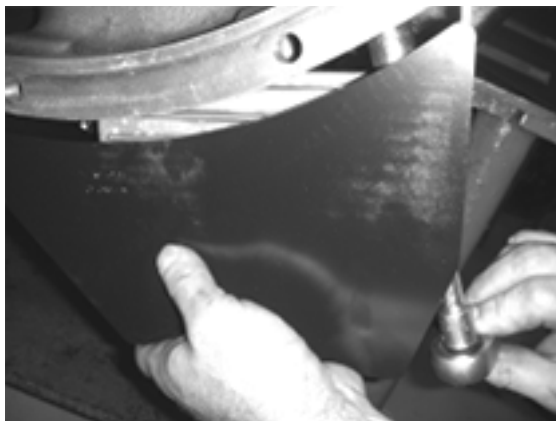

4. Remove the 4 cap screws from the ECA mounting flange.



5. Remove the ECA.

Note: The ECA has an alignment pin that requires the unit to be rotated to exit the clutch housing bore.

Note: If ECA will not slide from the clutch housing after all the fasteners are removed, use the available pusher holes found on both sides of the ECA casting. Place the included jackscrews into the holes. Turn each jackscrew until it touches. Next, turn the upper jackscrew 1 turn; then rotate to the lower jackscrew and rotate it 1 turn. Continue until the ECA is fully displaced from the bore.



Procedure - Installation

1. Install the ECA into the clutch housing bore. Align it with the lower cross-shaft.

Note: The ECA will have to be rotated to align with the slot in the Clutch Housing.

Note: Ensure you rotate the Release Yoke as close to the Case Dowel in the Clutch Housing prior to mating with the cross-shaft. This allows the Release Yoke to clear the Release Bearing during installation.



2. Install the 4 cap screws from the ECA Mounting Flange. Tighten them to 35-45 lb-ft. (47-61 Nm).

Note: Medium-duty models are mounted with 3 cap screws and 1 lock nut. Tighten to 35-45 lb-ft. (47-61 Nm).

Note: The cap screws for the ECA are longer than the ECA Bracket cap screws.

Note: Ensure the ECA does not bind on the cross-shaft by snugging all cap screws before tightening to the specified torque.



3. If applicable, install the 4 cap screws for the ECA shield. Tighten them to 35-45 lb-ft. (47-61 Nm).

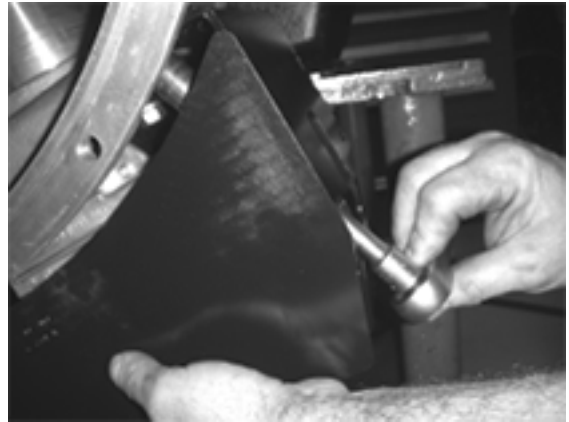

4. Apply NyoGel to terminals and reconnect the 8-way and 3-way connectors to the ECA.

Note: Apply just enough material to cover the end of the terminal.

Note: Use only Eaton lubricant part number 5564527 (Nye Lubricants NYOGEL 760G. For MSDS safety or other information see www.nyelubricants.com.)

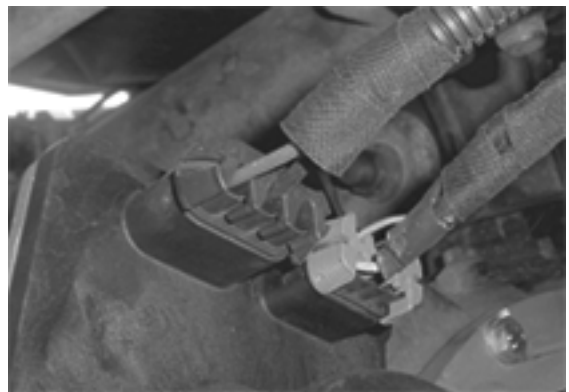

5. Reconnect the negative 12-volt battery cable.
6. If previously removed, install the 8-bolt PTO after ECA installation. Follow the PTO manufacturer's guidelines for installation instructions.

Low Capacity Inertia Brake

Special Instructions

None

Special Tools

Basic hand tools

Component Identification

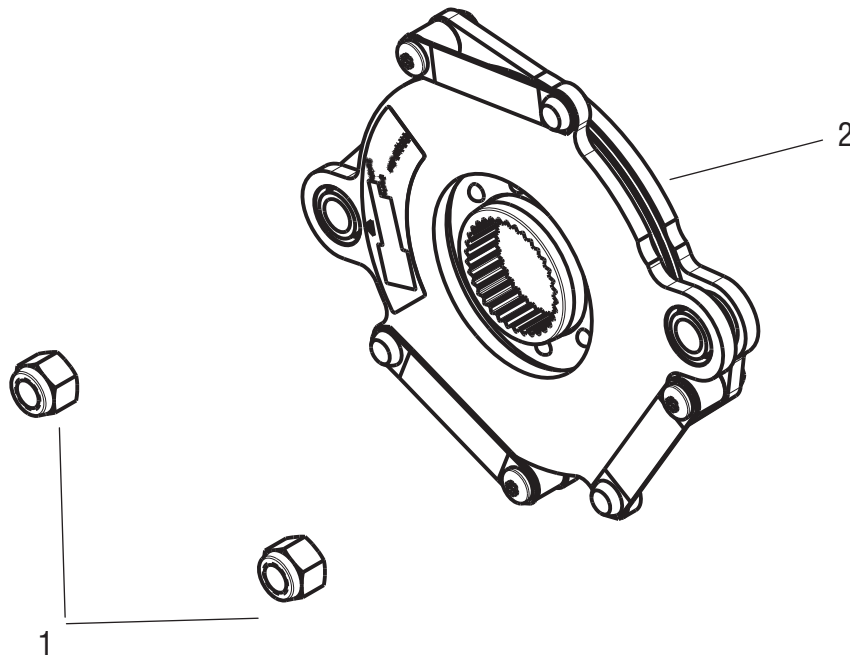

1. Mounting Nut
2. Low Capacity Inertia Brake (LCIB)

Procedure - Removal

Note: The Transmission and ECA must be removed prior to removing the LCIB.

1. Remove the 2 mounting nuts with a breaker bar and socket.



2. Remove the LCIB by hand by sliding off of the splined Input Shaft.



Procedure - Installation

1. Slide the LCIB onto the splined Input Shaft while centering the holes onto the retaining studs.



2. Install the 2 retaining nuts and torque nuts to 140-150 lb-ft. (190-203 Nm).

Note: The LCIB can only be installed one way. The label is toward the right side of the vehicle and facing the flywheel.



Release Yoke and Cross-shaft(s)

Special Instructions

None

Special Tools

Basic hand tools

Component Identification

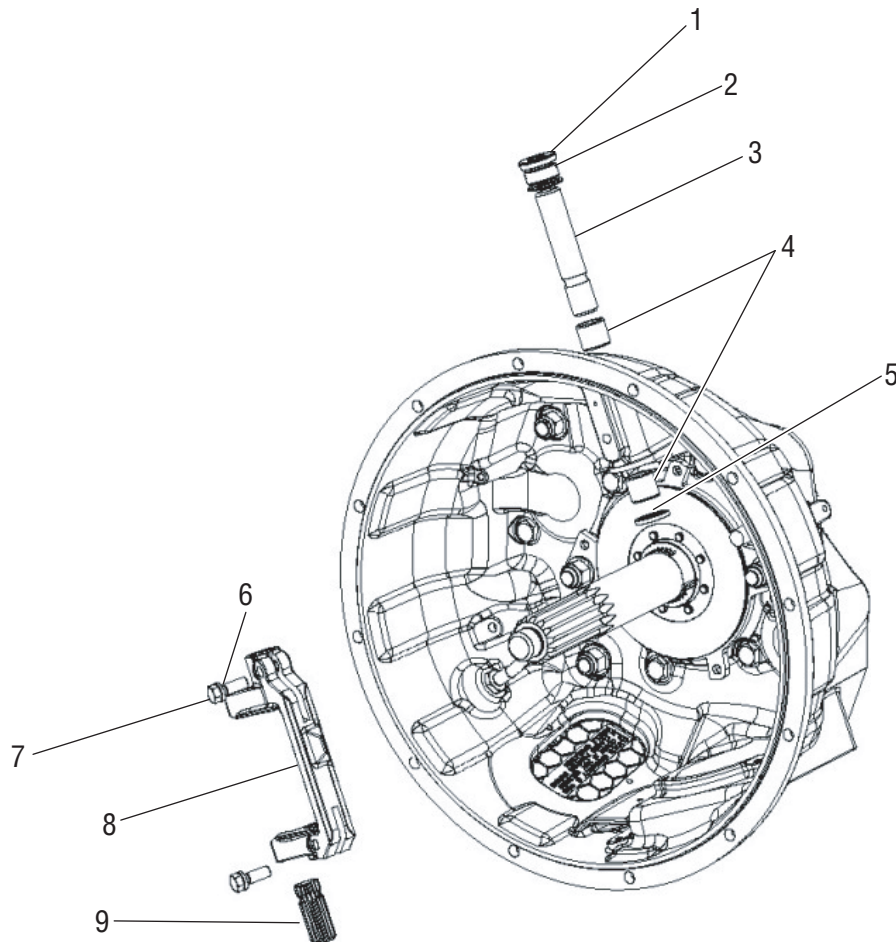

1. Plug
2. O-ring
3. Upper Cross-shaft
4. Bushing
5. Seal
6. Lock Washer
7. Mounting Screw
8. Release Yoke
9. Lower Cross-shaft

Procedure - Removal

Note: The Transmission and ECA must be removed prior to removing the Release Yoke and Cross-shaft(s).

1. Remove the upper and lower Cross-Shaft Mounting cap screws and lock washers from the Release Yoke.



2. Remove the lower Cross-Shaft and Release Yoke.



3. Remove the upper Cross-Shaft.



4. If necessary, remove the Cross-Shaft Plug with o-ring.



5. If necessary, remove the upper Cross-Shaft Seal assembly.



6. If necessary, remove the 2 upper Cross-Shaft bushings.



Procedure - Installation

1. If previously removed, install the 2 upper Cross-shaft bushings.

Note: Make sure to apply grease to the bushings.



2. If previously removed, install the upper Cross-shaft grease seal.

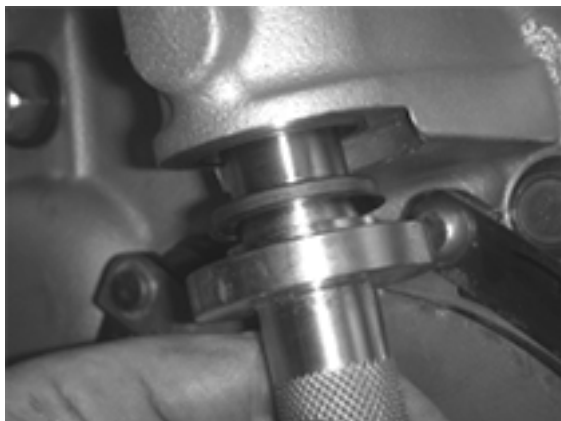

3. If previously removed, install the o-ring onto the Cross-shaft plug and then install the Cross-shaft plug into the transmission housing and torque to 34-48 lb-ft. (46-65 Nm).



4. Install the upper Cross-shaft into the bore.



5. Slide yoke onto upper Cross-shaft assembly and install 1 cap screw and lock washer by hand.



8. Grease upper Cross-shaft assembly until grease purges from the bleed hole in the upper Cross-shaft boss.

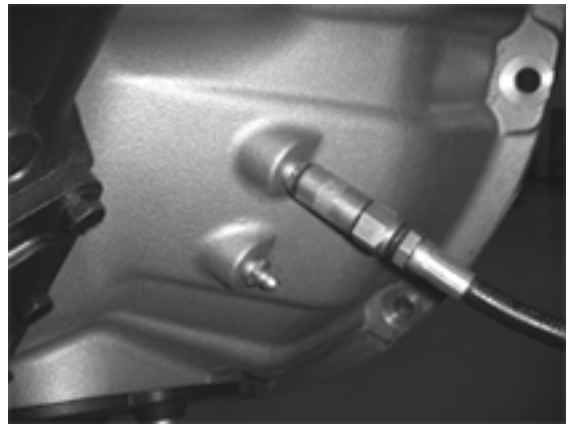

6. Install lower Cross-shaft assembly and install 1 cap screw and lock washer by hand.



7. Tighten the 2 Yoke cap screws to 35-45 lb-ft. (47-61 Nm).



Cobra Lever

Special Instructions

None

Special Tools

Basic hand tools

Component Identification

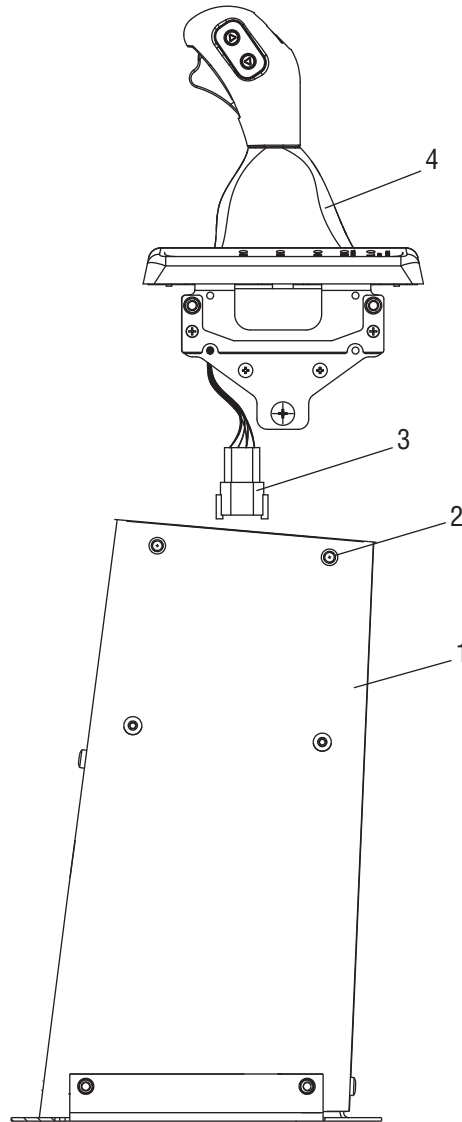

- 1. Tower
- 2. Screw
- 3. 8-Way Cobra Lever Harness Connector

Procedure - Removal

1. Using a Phillips screwdriver, remove the 4 screws from the Cobra Lever housing.



2. Disconnect the 8-way Cobra Lever Harness connector and remove the Cobra Lever from the housing.



Procedure - Installation

1. Connect the 8-way Cobra Lever Harness connector and place the Cobra Lever into the tower.

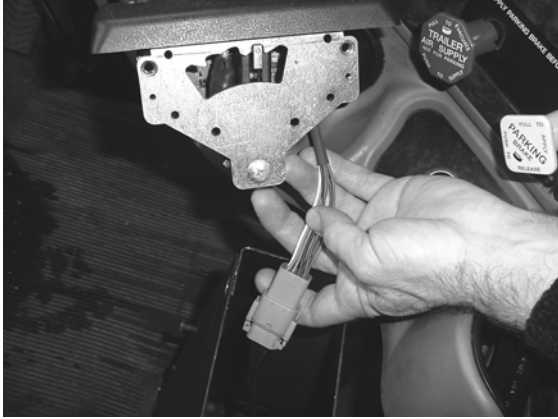

2. Using a Phillips screwdriver install the 4 screws into the Cobra Lever housing.



Shift Control

Special Instructions

The exact location varies depending on vehicle manufacturer.

Special Tools

Basic hand tools

Component Identification

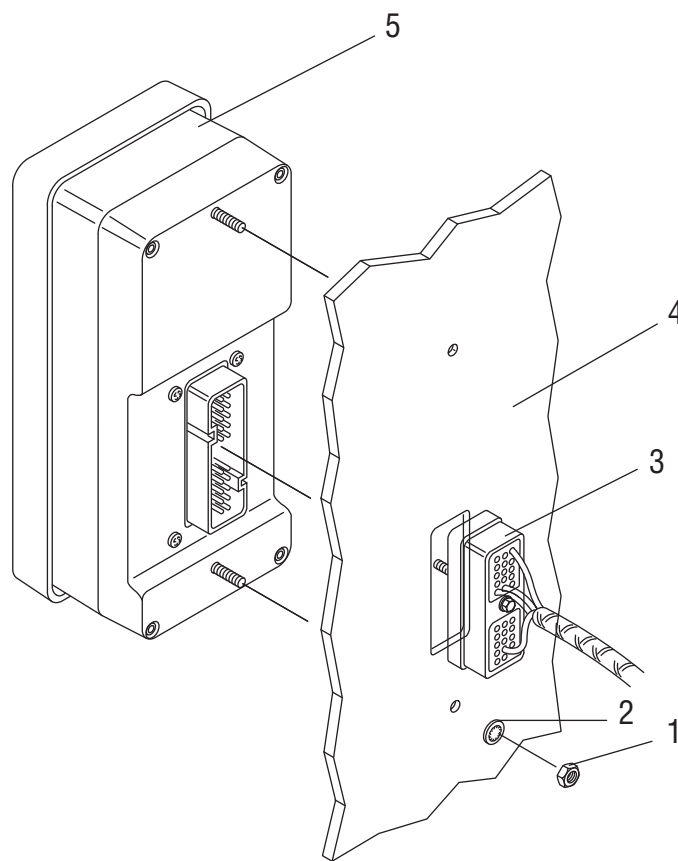

1. Nut
2. Washer
3. Push Button Shift Control 30-Way Connector
4. Backing Plate
5. Push Button Shift Control

Procedure - Removal

1. Using a 1/4" socket, loosen the retaining bolt and disconnect the 30-way connector from the back of the Shift Control.



2. Using a 11/32" wrench, remove the 2 nuts and lock washers from the back of the Shift Control and remove the Shift Control.

Note: Shift Control location and use varies with each truck.

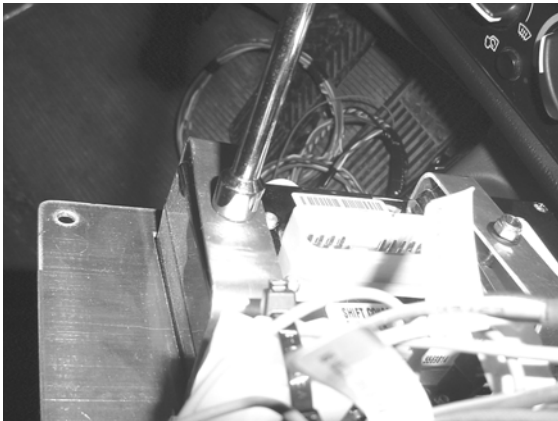

Procedure - Installation

1. Install the Shift Control in the mounting location. Then, using a 11/32" wrench, install the 2 lock washers and nuts and tighten to 14-16 lb-in. (18–21 Nm).

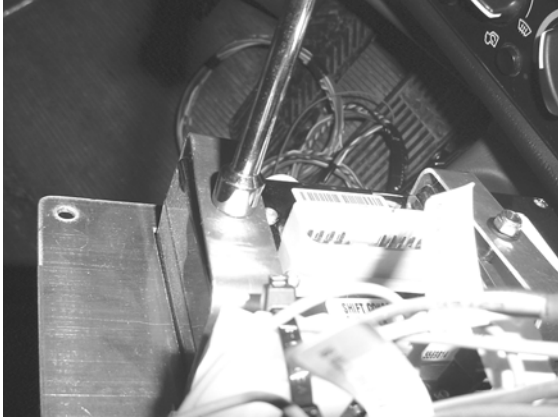

2. Using a 1/4" wrench, reconnect the 30-way connector to the back of the Shift Control and tighten to 10 +/- 3 lb-in. [13.5 +/- 4 Nm]



Medium-Duty Transmission Harness

Special Instructions

None

Special Tools

Basic hand tools

Component Identification

Medium-Duty

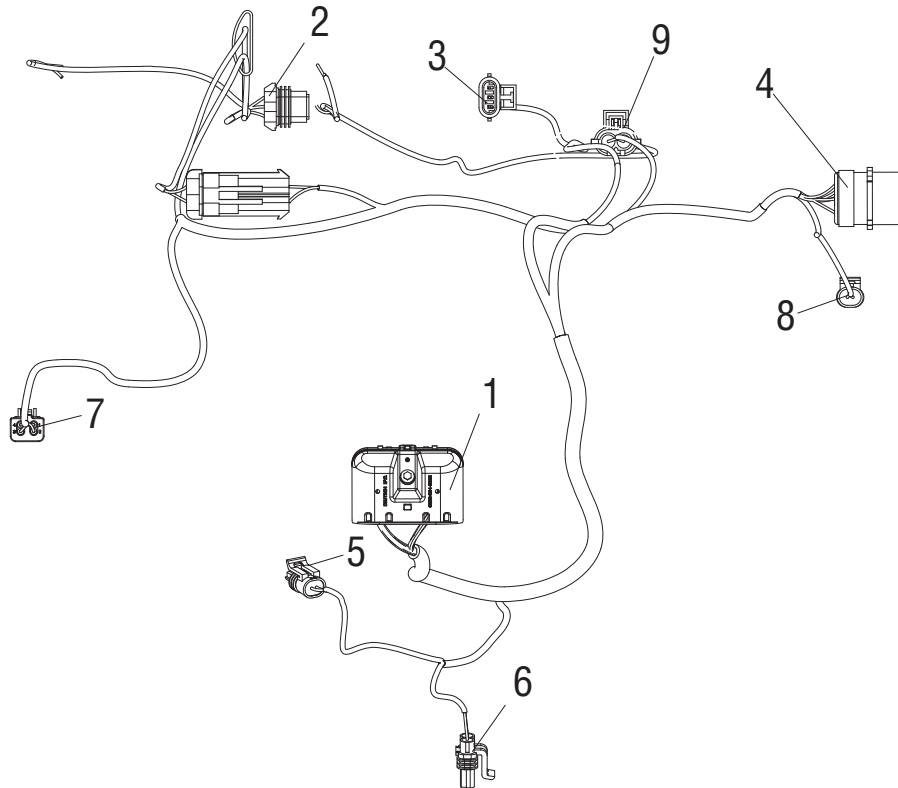

1. Transmission ECU 38-way Connector
2. Gear Sensor Connector
3. Rail Sensor Connector
4. Future position of 4-way Transmission Diagnostic Connector
5. Input Shaft Speed Sensor Connector
6. Inertia Brake Connector
7. Wet Clutch Solenoid Connector (AW3 only)
8. Output Shaft Speed Sensor Connector
9. Electric Shifter Connector

Procedure - Removal



Caution: The battery negative must be disconnected prior to unhooking the Transmission ECU (TECU) 38-way Connectors.



Caution: Do not allow contamination into the TECU or connectors.

1. Using a 5/32" hex wrench, disconnect the Transmission Harness 38-way Connector.





2. Disconnect the following harness connectors:
 - Inertia Brake Coil (if equipped)
 - Input Shaft Speed Sensor
 - Gear Select Sensor and Rail Select Sensor
 - Wet clutch solenoid (AW3 only)
 - Output Shaft Speed Sensor (location may vary)
 - 4-way Transmission Diagnostic connector
 - Electric Shifter

Procedure - Installation

 **Caution:** Do not allow contamination into the TECU Connectors.

 **Caution:** Do not over tighten tie-downs.

 **Caution:** Leave a service loop in the Transmission Harness.

 **Caution:** Do not put sharp bends in the Transmission Harness.

 **Caution:** The battery negative must be disconnected while installing the TECU connectors.

1. Reconnect the following harness connectors:
 - Gear Select and Rail Select Sensor
 - Input Shaft Speed Sensor
 - Inertia Brake Coil
 - Output Shaft Speed Sensor
 - 4-way Transmission Diagnostic connector
 - Electric Shifter
 - Wet clutch solenoid (AW3 only)
2. Using a 5/32" hex wrench, reconnect the Transmission Harness 38-way Connector and tighten to 22–28 lb-in. (29–37 Nm).

 **Caution:** Do not exceed the torque on the Transmission Harness or Vehicle Harness Connector or bolt failure will occur.



Heavy-Duty Transmission Harness

Special Instructions

None

Special Tools

Basic hand tools

Component Identification

Heavy-Duty

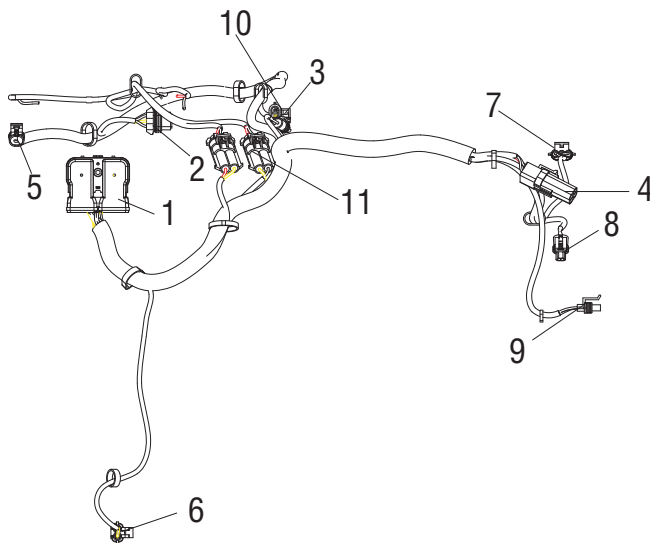

1. Transmission ECU 38-way Connector
2. Gear Sensor Connector
3. Rail Sensor Connector
4. 4-way Transmission Diagnostic Connector
5. Input Shaft Speed Sensor Connector
6. Inertia Brake Connector (DM3 models)
7. Range Solenoid Connector
8. Output Shaft Speed Sensor Connector
9. Splitter Solenoid Connector (13-,18-speeds only)
10. Mainshaft Speed Sensor Connector
11. Electric Shifter Connector

LAS/VAS Models

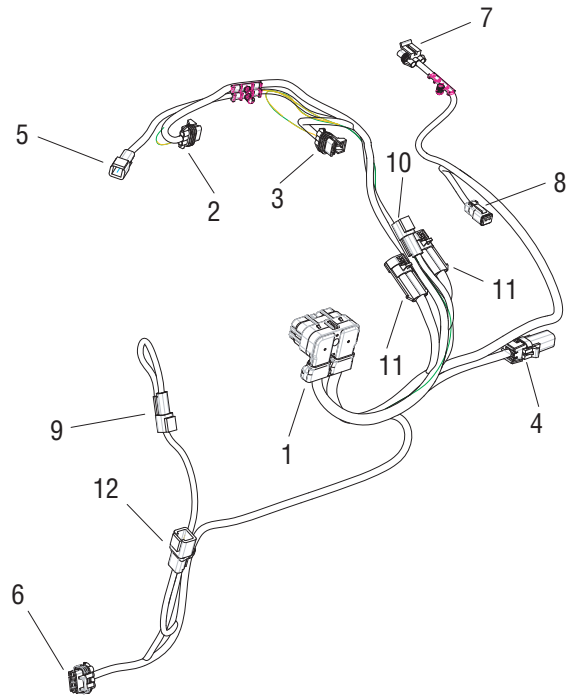

1. ECU 38-way Connector
2. Gear Sensor Connector
3. Rail Sensor Connector
4. 4-way Diagnostic Connector
5. Input Shaft Speed Sensor Connector
6. ECA 8-way Connector
7. Range Solenoid Connector
8. Output Shaft Speed Sensor Connector
9. Engine Speed Sensor Connector
10. Mainshaft Speed Sensor
11. Electric Shifter Connector
12. Terminating Resistor Connector

VMS and VCS Models

LSE, MHP/VHP and MXP/VXP Models

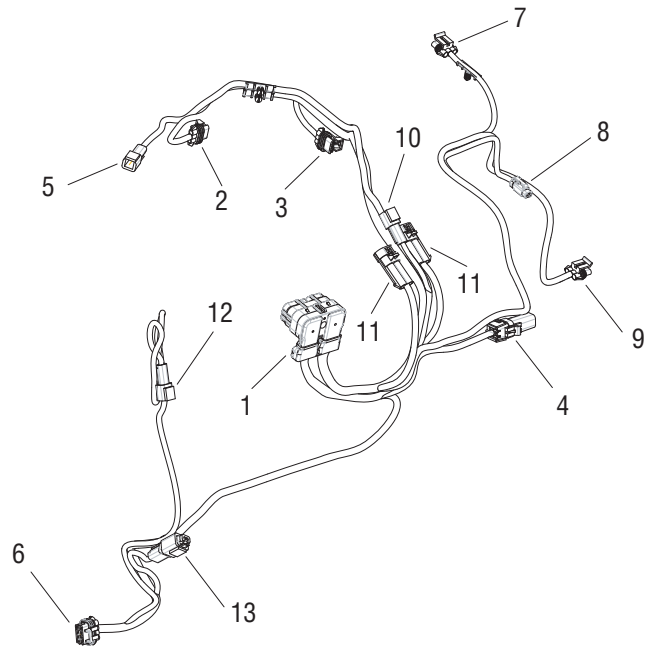
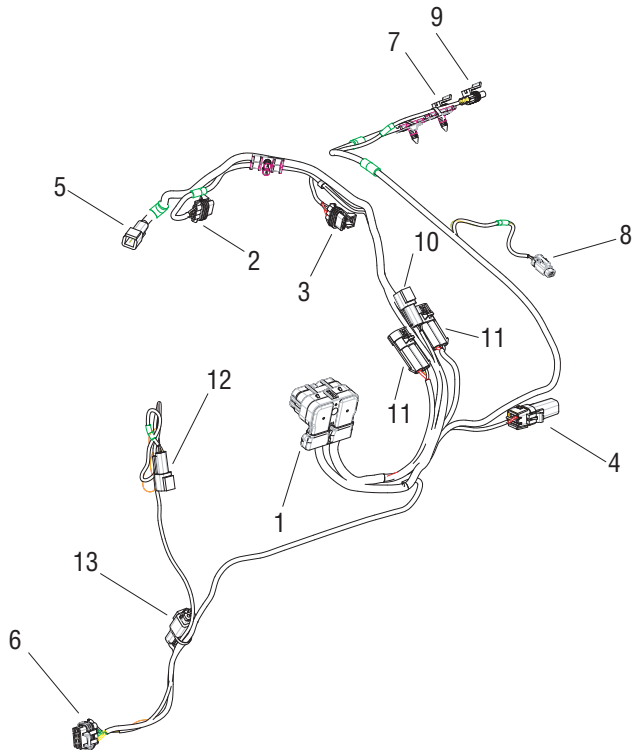

- 1. ECU 38-way Connector
- 2. Gear Sensor Connector
- 3. Rail Sensor Connector
- 4. 4-way Diagnostic Connector
- 5. Input Shaft Speed Sensor Connector
- 6. ECA 8-way Connector
- 7. Range Solenoid Connector
- 8. Output Shaft Speed Sensor Connector
- 9. Reduction Solenoid Connector
- 10. Mainshaft Speed Sensor
- 11. Electric Shifter Connector
- 12. Engine Speed Sensor Connector
- 13. Terminating Resistor Connector

- 1. ECU 38-way Connector
- 2. Gear Sensor Connector
- 3. Rail Sensor Connector
- 4. 4-Way Diagnostic Connector
- 5. Input Shaft Speed Sensor Connector
- 6. ECA 8-way Connector
- 7. Range Solenoid Connector
- 8. Output Shaft Speed Sensor Connector
- 9. Splitter Solenoid Connector
- 10. Mainshaft Speed Sensor
- 11. Electric Shifter Connector
- 12. Engine Speed Sensor Connector
- 13. Terminating Resistor Connector

Procedure - Removal



Caution: The battery negative must be disconnected prior to unhooking the TECU 38-way connectors.



Caution: Do not allow contamination into the TECU or connectors.

1. Disconnect the following connectors:
 - Using a 5/32" hex wrench, unscrew and disconnect the Transmission Harness 38-way Connector and Vehicle Interface 38-way Connector.

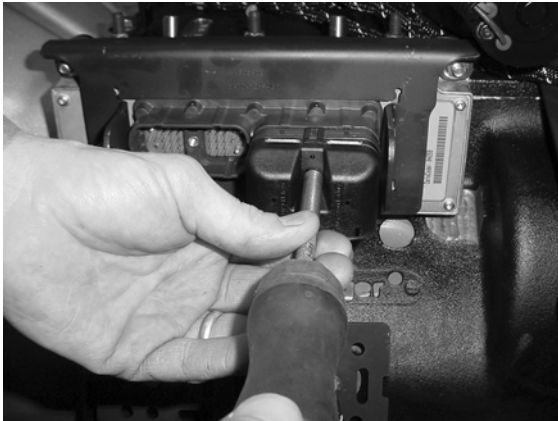

2. Disconnect the following harness connectors:
 - Inertia Brake Coil (if equipped)
 - Input Shaft Speed Sensor
 - Main Shaft Speed Sensor
 - Gear Select Sensor and Rail Select Sensor
 - Output Shaft Speed Sensor
 - Range and Splitter Valve Solenoids
 - 4-way Transmission Diagnostic connector
 - Electric Shifter

Procedure - Installation



Caution: Do not allow contamination into the TECU connectors.



Caution: Do not over tighten tie-raps.



Caution: You need to leave a service loop in the Transmission Harness.



Caution: Do not put sharp bends in the Transmission Harness.



Caution: The battery negative must be disconnected, while installing the TECU connectors.

1. Reconnect the following harness connectors:

- Gear Select and Rail Select Sensor
- Main Shaft Speed Sensor
- Input Shaft Speed Sensor
- Inertia Brake Coil (if equipped)
- Output Shaft Speed Sensor
- 4-way Transmission Diagnostic Connector
- Electric Shifter
- Range and Splitter Valve Solenoids

2. Using a 5/32" hex wrench, reconnect the Transmission Harness 38-way Connector and tighten to 25 +/- 3 lb-in. (2.82 +/- 0.33 Nm).



Caution: Do not exceed the torque on the Transmission Harness or Vehicle Harness Connector or bolt failure will occur.

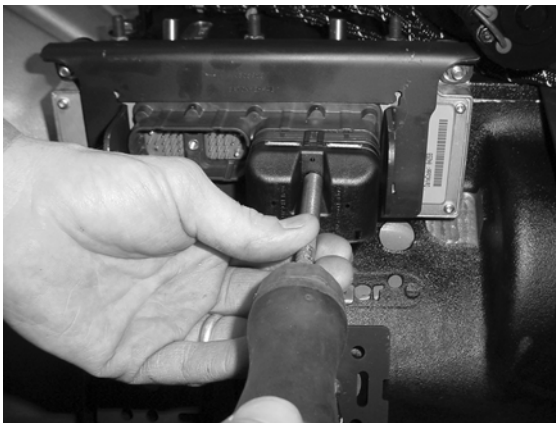

Medium-Duty Transmission Electronic Control Unit (TECU)

Special Instructions

None

Special Tools

Basic hand tools

Component Identification

Medium-Duty

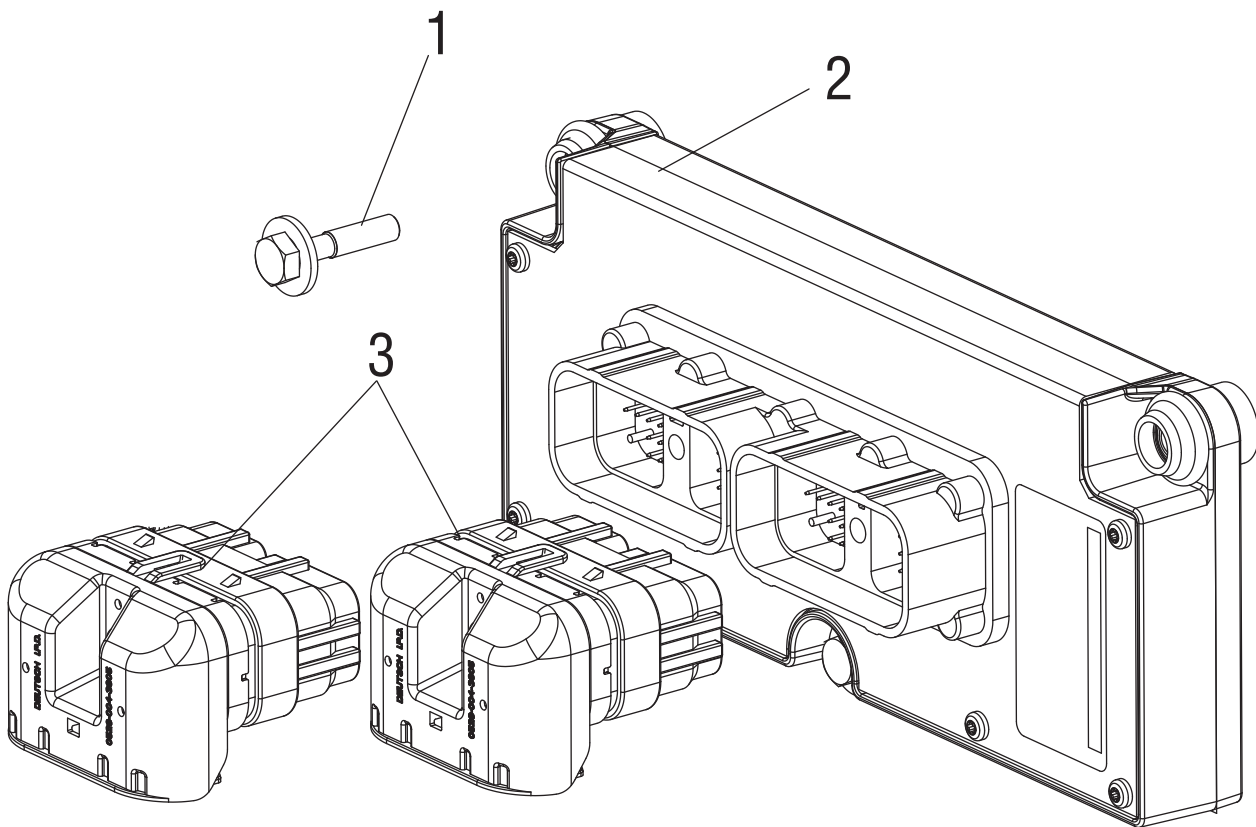

1. Cap Screw
2. Transmission ECU (TECU)
3. 38-way Connectors
4. Cap Screw (Located inside 38-way connectors)

Procedure - Removal



Caution: The battery negative must be disconnected prior to unhooking the Transmission ECU (TECU) 38-way connectors.



Caution: Do not allow contamination into the TECU or connectors.

1. Connect ServiceRanger to vehicle and record current configuration settings before removing the TECU from the transmission. (Refer to "ServiceRanger User Guide" TCMT-0071 for more information.)
2. Disconnect the following connectors:
 - Using a 5/32" hex wrench, unscrew and disconnect the Transmission Harness 38-way Connector and Vehicle Interface 38-way Connector.



3. Using a 7/16" socket, remove the 3 mounting bolts.

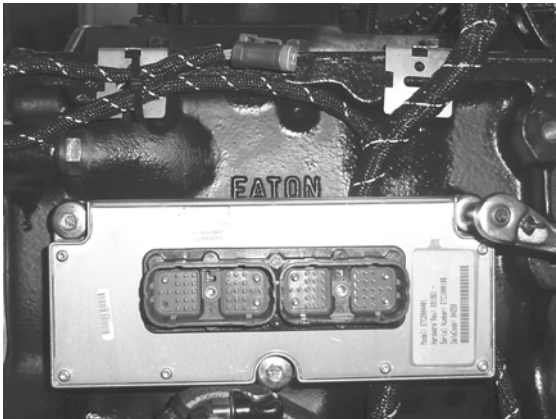

4. Remove the Transmission Controller assembly from the locating studs.

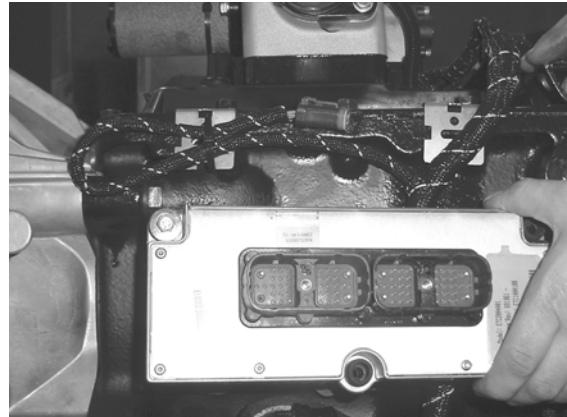

Procedure - Installation

Caution: Battery negative must remain disconnected until the TECU 38-way connectors are installed.

Caution: Do not allow contamination into the TECU or connectors.

1. Position the Transmission Controller on the locating studs.

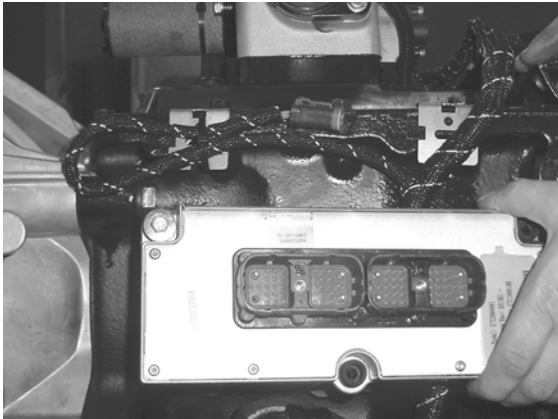

2. Using a 7/16" socket, install the 3 Transmission Controller mounting bolts and tighten to 7-9 lb-ft. (9.5-12.2 Nm).



3. Reconnect the following connectors:

Caution: Do not exceed the torque on the Transmission Harness or Vehicle Harness Connector or bolt failure will occur.

- Using a 5/32" wrench, reconnect the Transmission Harness 38-way Connector and tighten to 25 +/- 3 lb-in. (2.82 +/- 0.33 Nm).
- Using a 5/32" wrench, reconnect the Vehicle Interface 38-way Connector and tighten to 25 +/- 3 lb-in. (2.82 +/- 0.33 Nm).
- Reconnect the negative battery cable.



4. To operate properly, the system must be calibrated as follows:



Important: The Electric Shifter must be calibrated before the vehicle is placed in operation.

- Turn ignition switch on. Allow the transmission to power up.
- Turn ignition off and wait 2 minutes.

Note: UltraShift AW3- Perform clutch calibration: "Clutch Calibration" on page 143.

5. Connect ServiceRanger to vehicle and compare recorded configuration settings (step 1 in removal process) to the replacement TECU. Update and save all configurations that are different. (Refer to "ServiceRanger User Guide" TCMT-0071 for more information.)

Heavy-Duty Transmission Electronic Control Unit (TECU)

Special Instructions

None

Special Tools

Basic hand tools

Component Identification

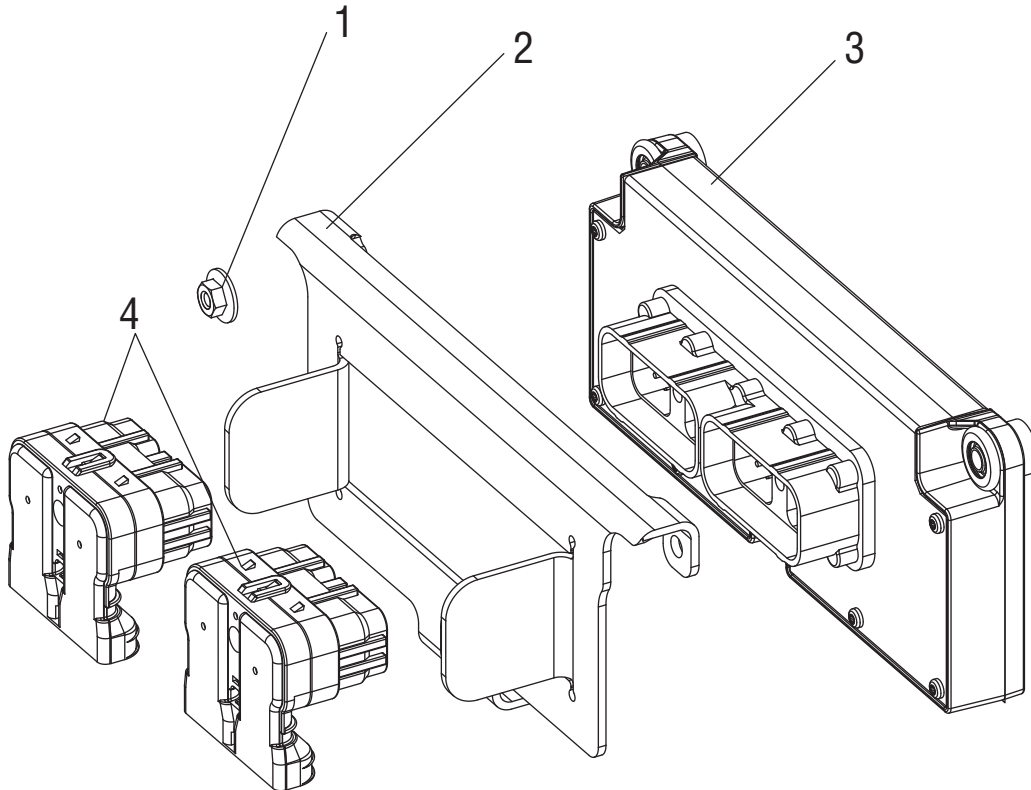

1. Nut
2. Bracket
3. Transmission ECU (TECU)
4. 38-Way Connectors
5. Cap Screw (Located inside 38-way connectors)

Procedure - Removal



Caution: The battery negative must be disconnected prior to unhooking the Transmission ECU (TECU) 38-way connectors.



Caution: Do not allow contamination into the TECU or connectors.

1. Connect ServiceRanger to vehicle and record current configuration settings before removing the TECU from the transmission. (Refer to "ServiceRanger User Guide" TCMT-0071 for more information.)
2. Disconnect the following connectors:
 - Using a 5/32" hex wrench, unscrew and disconnect the Transmission Harness 38-way Connector and Vehicle Interface 38-way Connector.

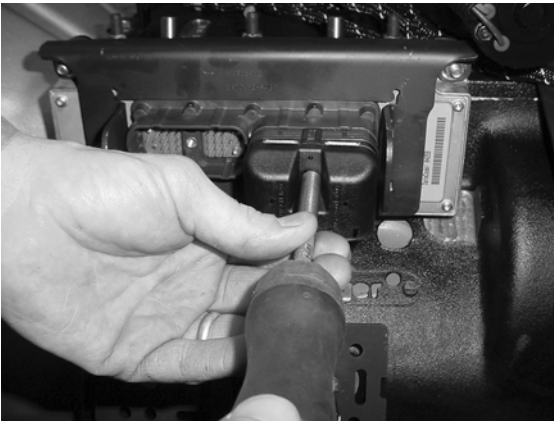

3. Using a 7/16" socket, remove the 3 mounting nuts.



4. Remove the Transmission Controller Retaining Bracket.

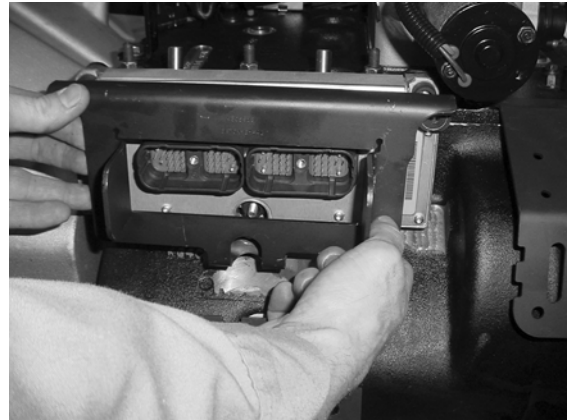

5. Remove the Transmission Controller assembly from the locating studs.



Procedure - Installation

Caution: Battery negative must remain disconnected until the TECU 38-Way connectors are installed.

Caution: Do not allow contamination into the TECU or connectors.

1. Position the Transmission Controller on the locating studs.



2. Place the Transmission Controller retaining bracket over the TECU.

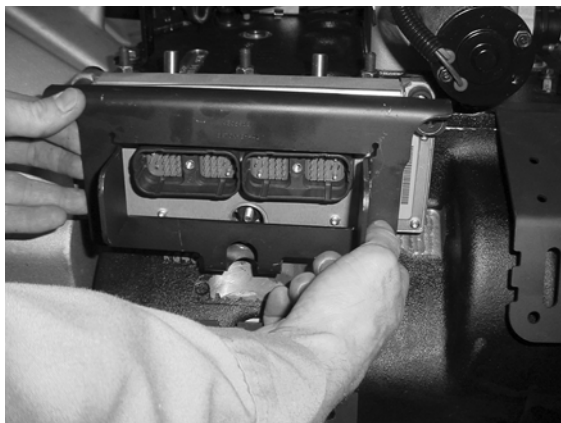

3. Using a 7/16" socket, install the 3 Transmission Controller mounting nuts and tighten to 7-9 lb-ft. (9.5-12.2 Nm).



4. Reconnect the following connectors:

Caution: Do not exceed the torque on the Transmission Harness or Vehicle Harness Connector or bolt failure will occur.

- Using a 5/32" wrench, reconnect the Transmission Harness 38-way Connector and tighten to 25 +/- 3 lb-in. (2.82 +/- 0.33 Nm).
- Using a 5/32" wrench, reconnect the Vehicle Interface 38-way Connector and tighten to 25 +/- 3 lb-in. (2.82 +/- 0.33 Nm).
- Reconnect the negative battery cable.

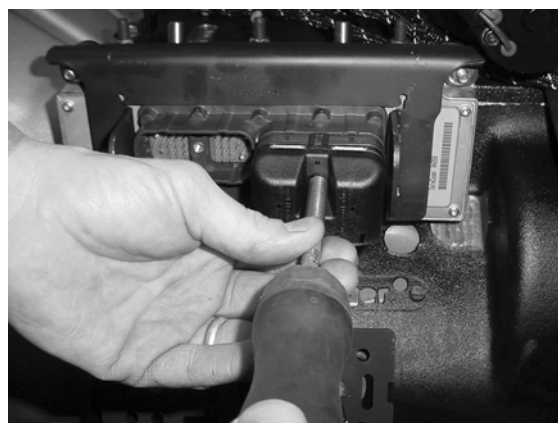

5. Connect ServiceRanger to vehicle and compare recorded configuration settings (step 1 in removal process) to the replacement TECU. Update and save all configurations that are different. (Refer to “ServiceRanger User Guide” TCMT0071 for more information.)
6. To operate properly, the system must be calibrated as follows:



Important: The Electric Shifter must be calibrated before the vehicle is placed in operation.

- a. Turn ignition switch on. Allow transmission to power up.
- b. Turn ignition off. Wait 2 minutes.

Electric Shifter

Special Instructions

None

Special Tools

Basic hand tools

Component Identification

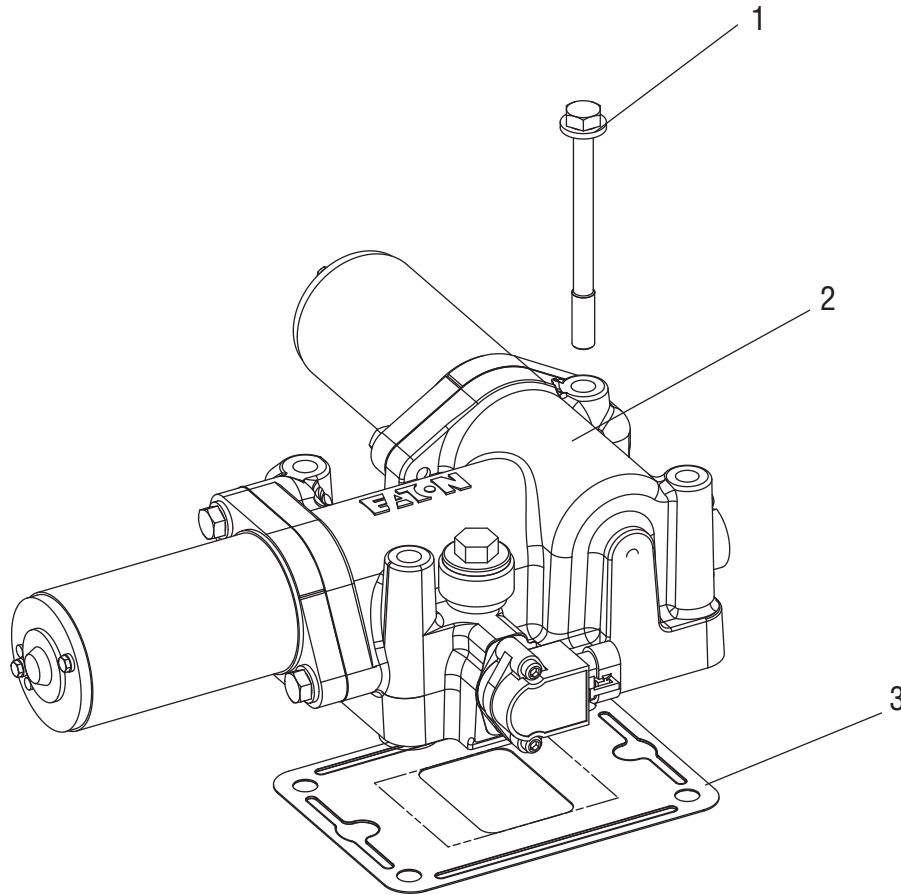

- 1. Cap Screw
- 2. Electric Shifter
- 3. Gasket

Procedure - Removal

1. Remove nylon cable ties from motor wires. Disconnect Transmission Harness from the Rail Select Sensor and the Gear Select Sensor.



2. Disconnect the Rail Select and Gear Select Motors from the Transmission ECU (TECU).

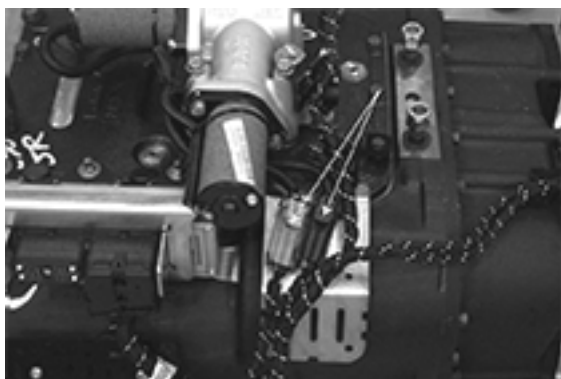

3. Using a 9/16" socket, remove the 4 mounting cap screws.

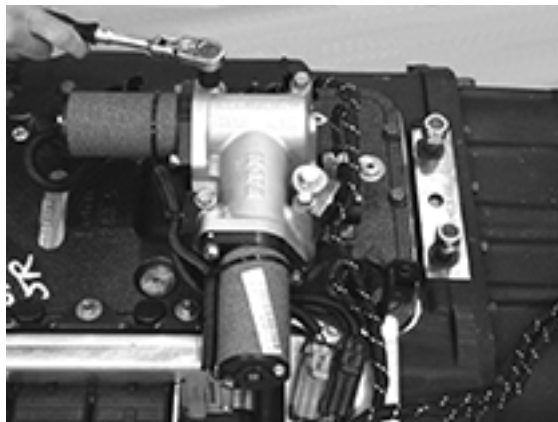

4. Remove X-Y Shifter and gasket.



Warning: Possible Pinch Point - Ensure battery is disconnected before removing X-Y Shifter.

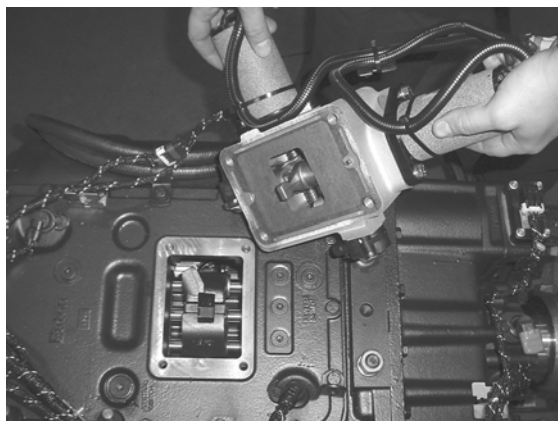

Procedure - Installation

1. Ensure Shift Blocks are in the neutral position, then move Shift Finger to the center (neutral) location.

Note: If the Shift Finger is not properly aligned, the X-Y Shifter will not fit properly at its mounting location.

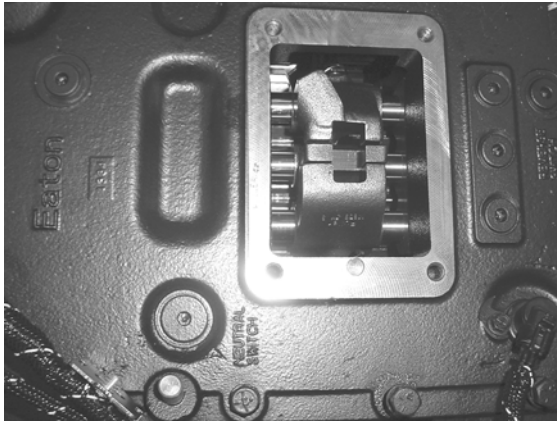

2. Clean and remove old gasket material from Shift Bar Housing. Then, install new gasket on the Shift Bar Housing.

Note: Apply Eaton sealant part number 71205 or equivalent to the mounting cap screws before installing.

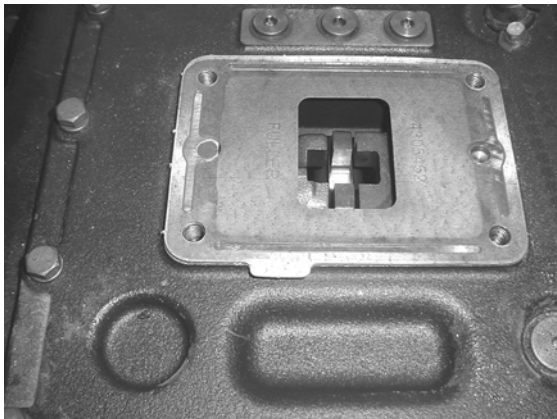

3. The dowel pin on the X-Y Shifter must be aligned with hole in the Shift Bar Housing (used only on 10-, 13- and 18-Speed models).

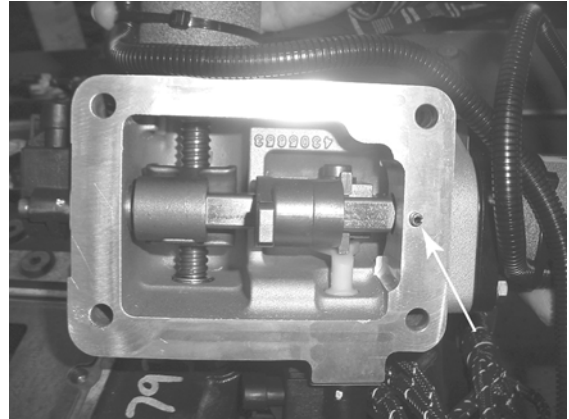

4. Position X-Y Shifter on the Shift Bar Housing. Using a 9/16" socket, install mounting cap screws and tighten in a cross pattern as follows:
 - 5- and 6-Speed (aluminum housing)- Tighten to 20-25 lb-ft. (27-34 Nm).
 - 10- 13- and 18-Speed (cast iron housing) - Tighten to 34-45 lb-ft. (45-60 Nm).

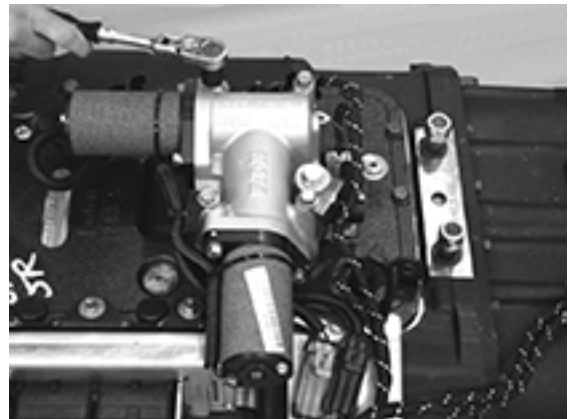

5. Reconnect the Rail Select Sensor and Gear Select Sensor.



6. Reconnect the Transmission Harness to the Rail Select and Gear Select motors. Using nylon ties, secure motor wires to the transmission in their previous position.

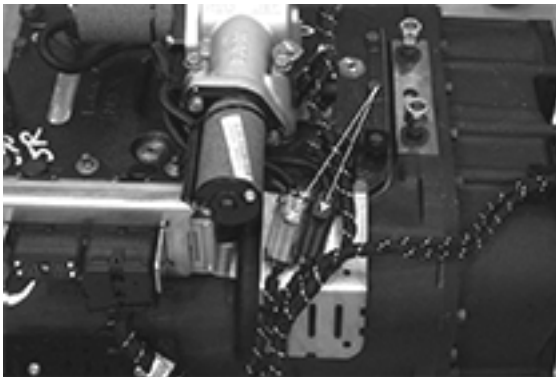

7. To operate properly, the system must be calibrated as follows:



Important: X-Y Shifter must be calibrated before the vehicle is placed into operation.

- Turn ignition switch on. Allow the transmission to power up.
- Turn ignition switch off. Wait 2 minutes.

Medium-Duty Inertia Brake

Special Instructions

None

Special Tools

Basic hand tools

Component Identification

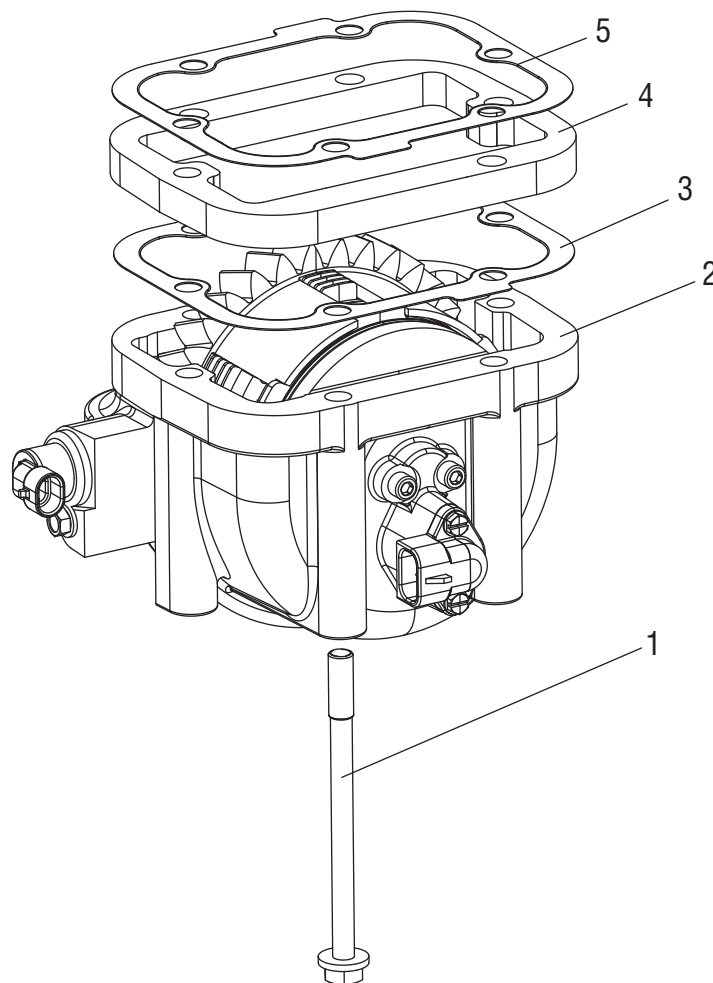

1. Cap Screw
2. Inertia Brake
3. Gasket
4. Spacer (Used on all Medium-Duty ratios except the "N")
5. Gasket (Used on all Medium-Duty ratios except the "N")

Procedure - Removal

1. Drain the lubrication from transmission and disconnect the Transmission Harness from the Input Shaft Speed Sensor and Inertia Brake Coil.

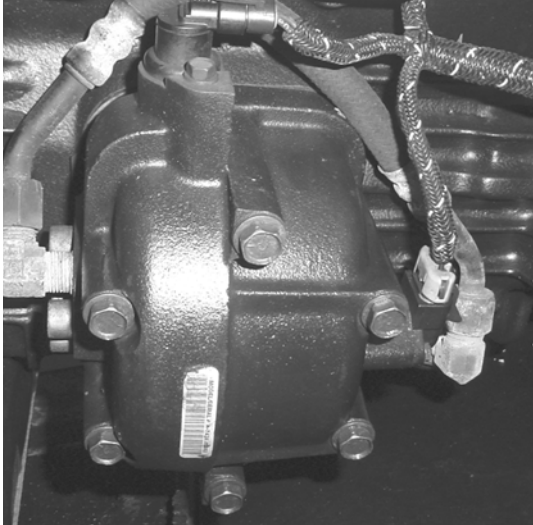

2. Using a 3/8" wrench, remove Input Shaft Speed Sensor.

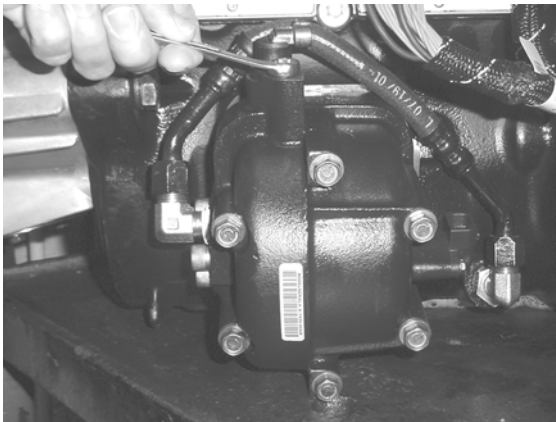

3. Using a 7/8" wrench, remove the lubricant supply line from the transmission.

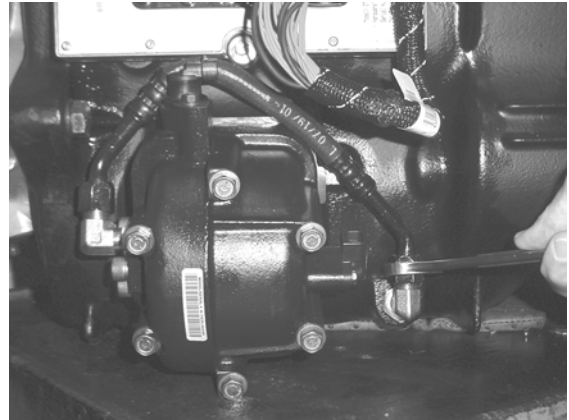

4. Using a 9/16" wrench, remove the 6 mounting bolts from the Inertia Brake.



Caution: The Inertia Brake is heavy. Be prepared to handle the weight of the Inertia Brake when mounting bolts are removed.

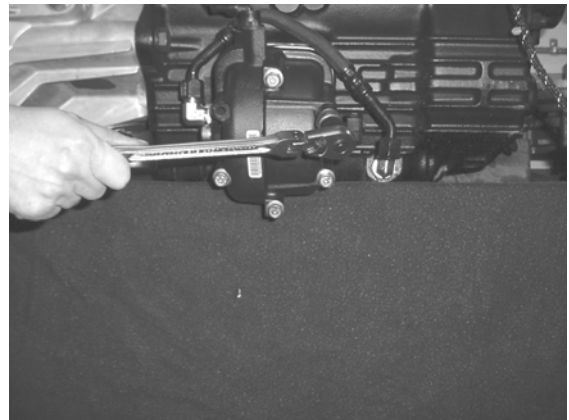

5. Remove the Inertia Brake, gaskets and spacer (depending on model) from the transmission.

Note: The Inertia Brake will contain some lubricant.

Note: The spacer and extra gasket are used on all transmission ratios except the N.

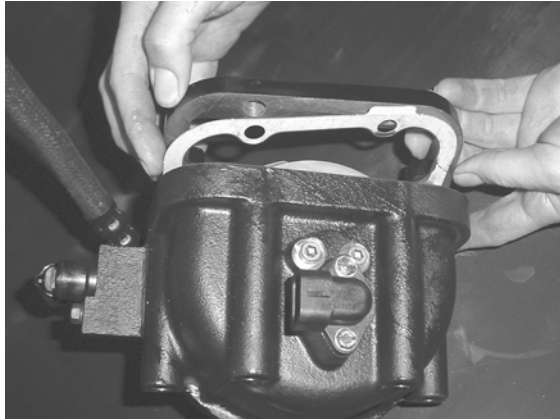

Procedure - Installation



Warning: The Inertia Brake is heavy. Be prepared to handle weight of the Inertia Brake until mounting bolts are installed.

1. Install Inertia Brake, gaskets and spacer (depending on model) being careful to align the Inertia Brake gear with the drive gear.

Note: The spacer and extra gasket are used on all transmission ratios except N.

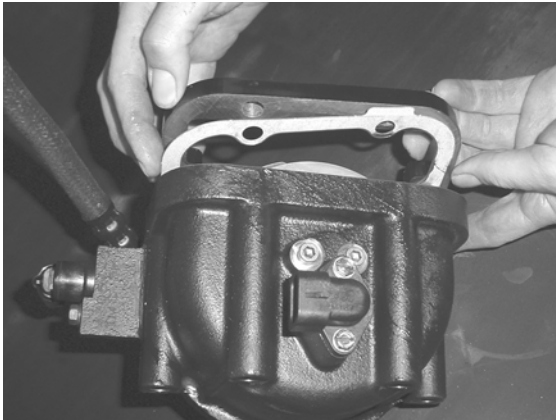

2. Using a 9/16" socket, install the 6 mounting bolts. Tighten mounting bolts to 35-45 lb-ft. (47-60 Nm) using a cross pattern.

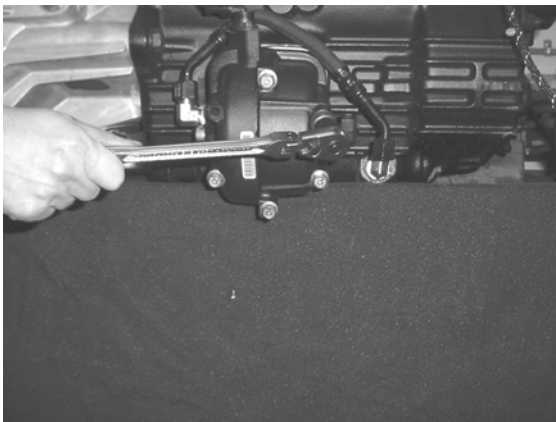

3. Using a 7/8" wrench, reconnect Inertia Brake lubricant supply line to the transmission and tighten to 20-22 lb-ft. (27-29 Nm).

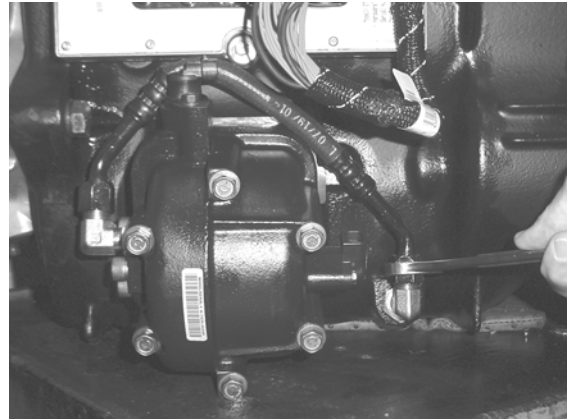

4. Using a 3/8" wrench, install Input Shaft Speed Sensor and tighten to 8-12 lb-ft. (11-16 Nm).



5. Reconnect the Transmission Harness to Input Shaft Speed Sensor and Inertia Brake Coil.

Note: Fill transmission with lubricant See “Lubrication Specifications” on page 141.



Air Filter Regulator

Special Instructions

The Air Filter Regulator has 2 o-rings located between the Air Filter/Regulator and the Range or Combination Cylinder Cover.

Special Tools

Basic hand tools

Component Identification

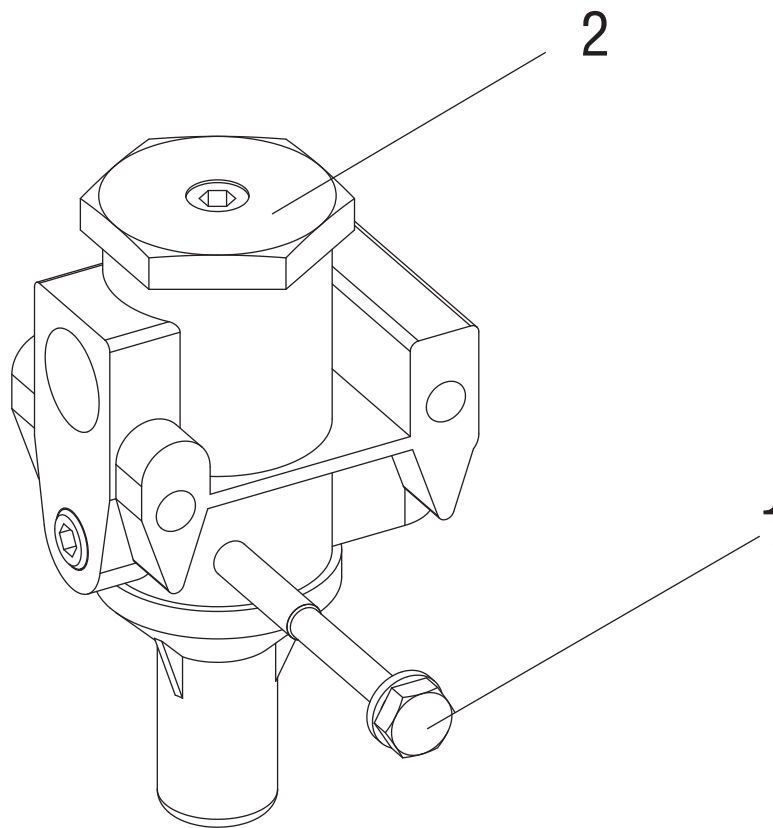

1. Air Filter Regulator
2. Cap Screw

Procedure - Removal

1. Relieve system air pressure by draining all air tanks on the vehicle. Then, remove the vehicle air supply line from the Air Filter Regulator.

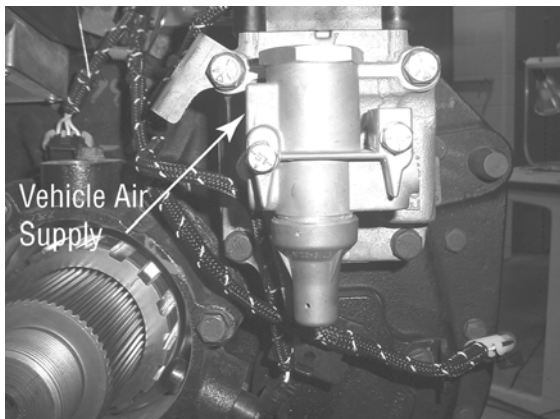

2. Using a 7/16" socket, remove the 2 mounting cap screws.

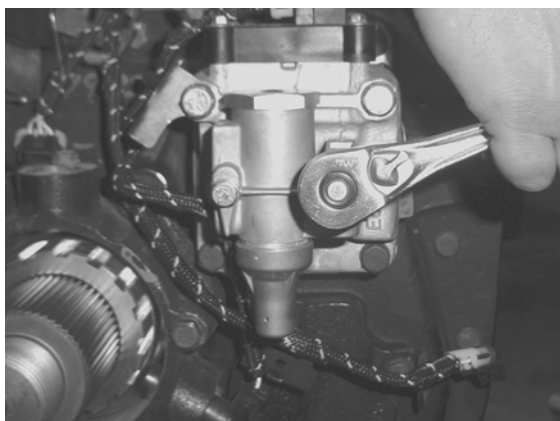

3. Remove the Air Filter Regulator assembly.

Note: Be careful not to let the o-rings drop out of the Range or Combination Cylinder Cover when removing the Air Filter Regulator.

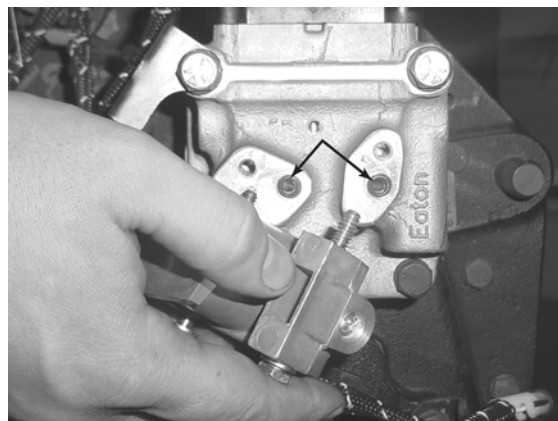

Procedure - Installation



Important: Lubricate o-rings with Eaton Fuller silicone 71214 or Equivalent.

1. If removed, press the two o-rings into the recesses in the Range or Combination Cylinder Cover.

Note: Apply Eaton Fuller sealant 71205 or equivalent to the two (2) mounting cap screws.

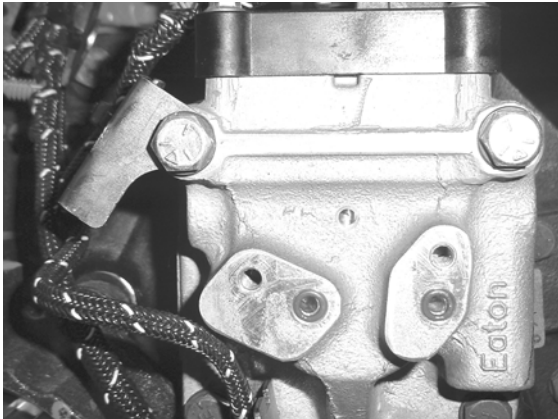

2. Using a 7/16" socket, install the 2 mounting cap screws and tighten to 8-12 lb-ft. (11-16 Nm).

Note: Hold the Air Filter Regulator flush with the Range Cylinder Cover until in place to prevent the o-rings from dropping out.

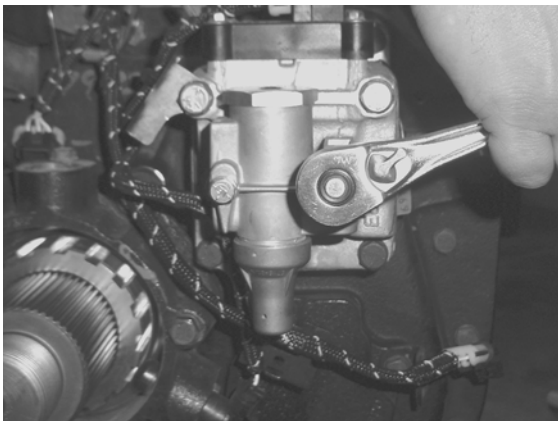

3. Reinstall the vehicle air supply line to the Air Filter Regulator and close all air tank drains.

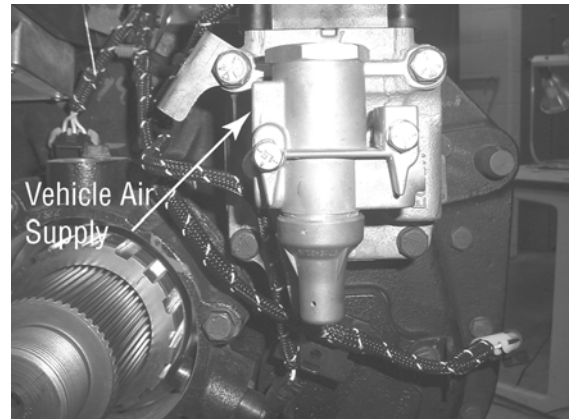

Heavy-Duty Inertia Brake

Special Instructions

None

Special Tools

Basic hand tools

Component Identification

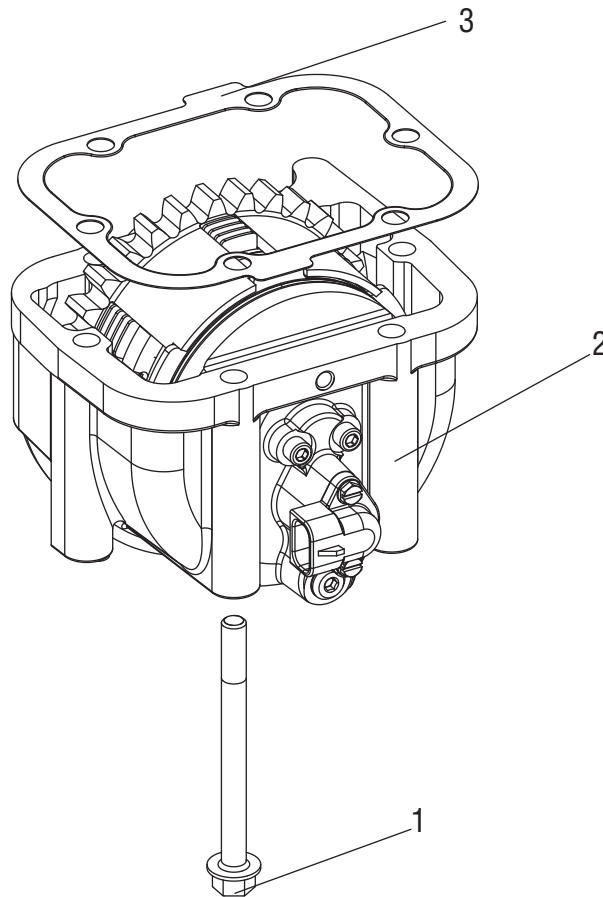

- 1. Cap Screw
- 2. Inertia Brake
- 3. Gasket

Procedure - Removal

1. Drain the lubricant from the transmission and disconnect the Transmission Harness from the Inertia Brake Coil.



2. Using a 7/8" wrench, disconnect the Inertia Brake lubricant supply line from the transmission.

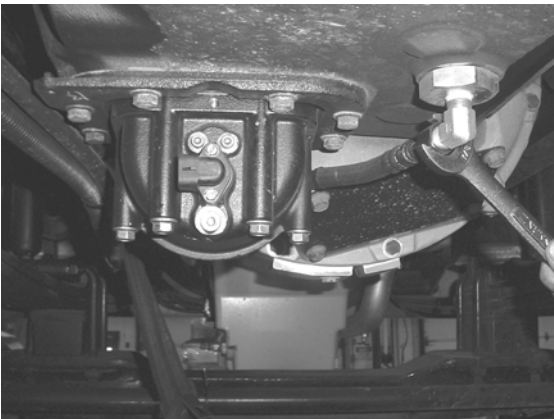

3. Using a 9/16" socket, remove the 6 mounting bolts from the Inertia Brake.



Caution: The Inertia Brake is heavy. Be prepared to handle the weight of the Inertia Brake when the mounting bolts are removed.

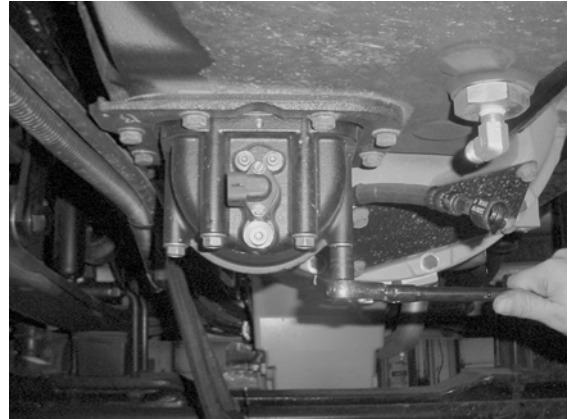

4. Remove the Inertia Brake and gasket from the transmission.



Procedure - Installation



Warning: The Inertia Brake is heavy. Be prepared to handle the weight of the Inertia Brake until the mounting bolts are installed.

1. Clean and remove all old gasket material. Then, install the Inertia Brake and new gasket, being careful to align the Inertia Brake gear with the drive gear.



2. Using a 9/16" socket, install the 6 mounting bolts. Tighten mounting bolts to 35-45 lb-ft. (47-60 Nm) using a cross pattern.

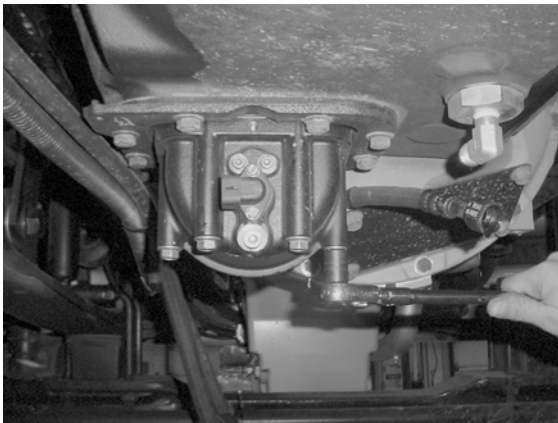

3. Using a 7/8" wrench, reconnect the Inertia Brake lubricant supply line to the transmission and tighten to 20-22 lb-ft. (27-29 Nm).



4. Reconnect the Transmission Harness to the Inertia Brake Coil.

Note: Fill the transmission with lubricant. See "Lubrication Specifications" on page 141..

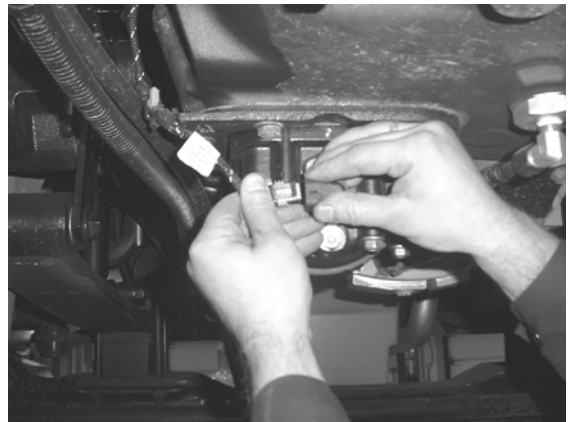

Combination Valves (Range and Deep Reduction)

Special Instructions

Torques given below are in lb-in.

Special Tools

Basic hand tools

Component Identification

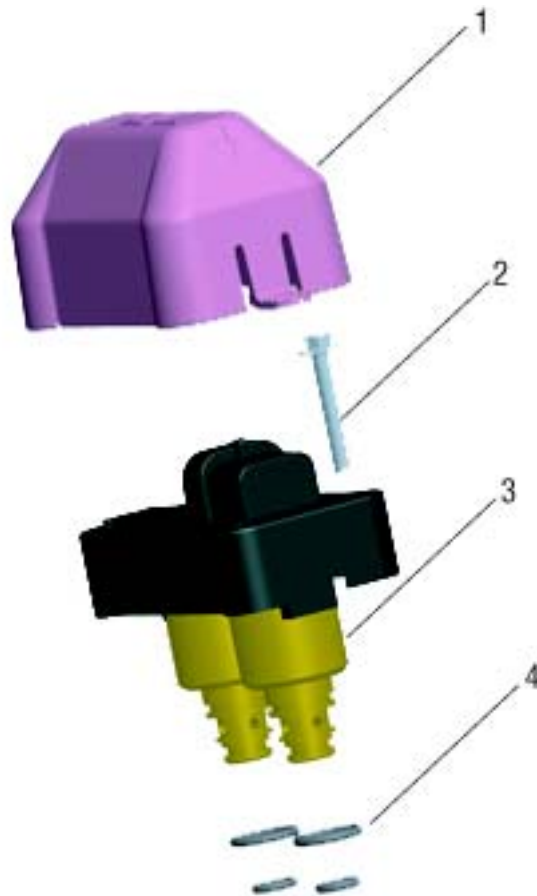

- 1. Protective Cover (Optional)
- 2. Cap Screw
- 3. Valve
- 4. O-rings

Procedure - Removal

Note: Follow same procedure for the removal of Deep Reduction or Range Valve.

1. If equipped, remove Protective Cover by pulling up on the Release Tab.

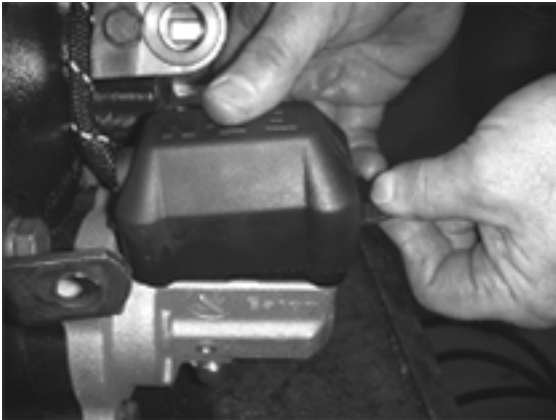

2. Relieve system air pressure by draining air tanks on the vehicle. When air pressure has been relieved, disconnect the Transmission Harness from the Valve.

Note: The harness should be removed from the Valve tie-down prior to removing the cap screws.



3. Using a 5/16" socket, remove the 4 mounting cap screws from the valve.

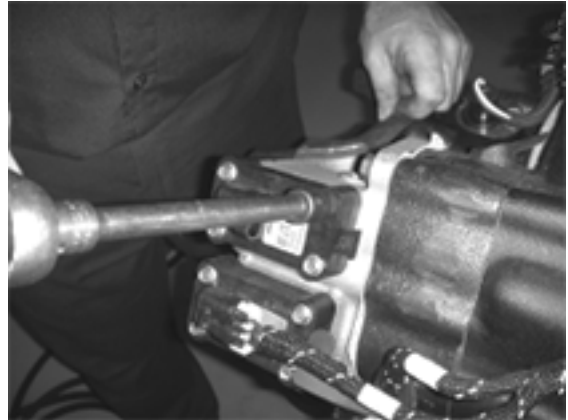

4. Lift and remove the valve from the housing.



Caution: Do not use a hammer to loosen the valve in the housing or it could be damaged.



Procedure - Installation

 **Important:** Lubricate o-rings with Eaton Fuller silicone 71214 or equivalent.

 **Important:** The valve is keyed to fit its mounting location. Take care to align the key in the valve with the notch in the housing.

Note: Follow same procedure for installing the Deep Reduction Valve or Range Valve.

1. Install and push the valve down into the housing.



2. Using a 5/16" socket, install the valve mounting cap screws and tighten to 21-27 lb-in. (2.3-3.0 Nm) using a cross pattern.

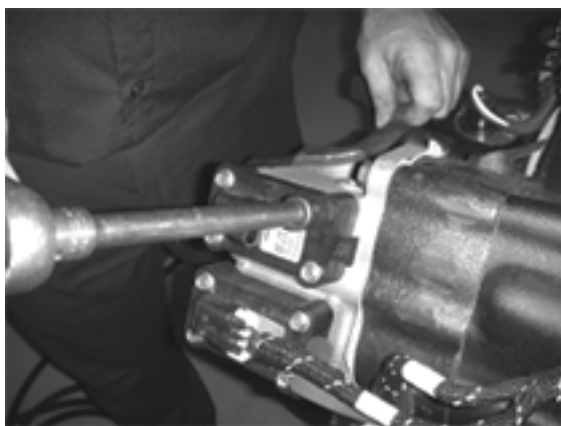

3. Reconnect the Transmission Harness to the valve and close all air tanks drains.

Note: Install the Range Harness back into the tie-down on the valve.

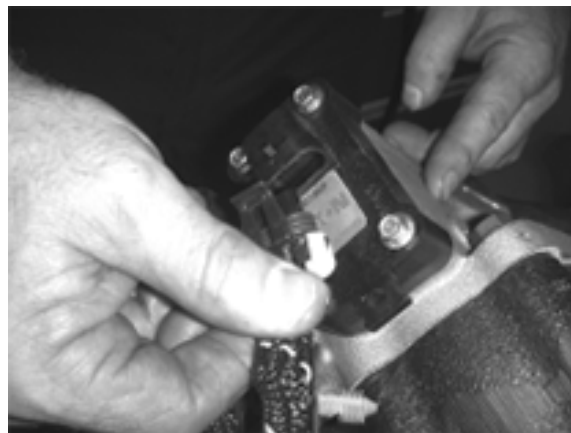

4. If equipped, install the Protective Cover. Push the cover down by hand until it snaps into place.



Range Valve

Special Instructions

The Range Valve may be difficult to remove from the Transmission Housing because of the o-rings.

Special Tools

Basic hand tools

Component Identification

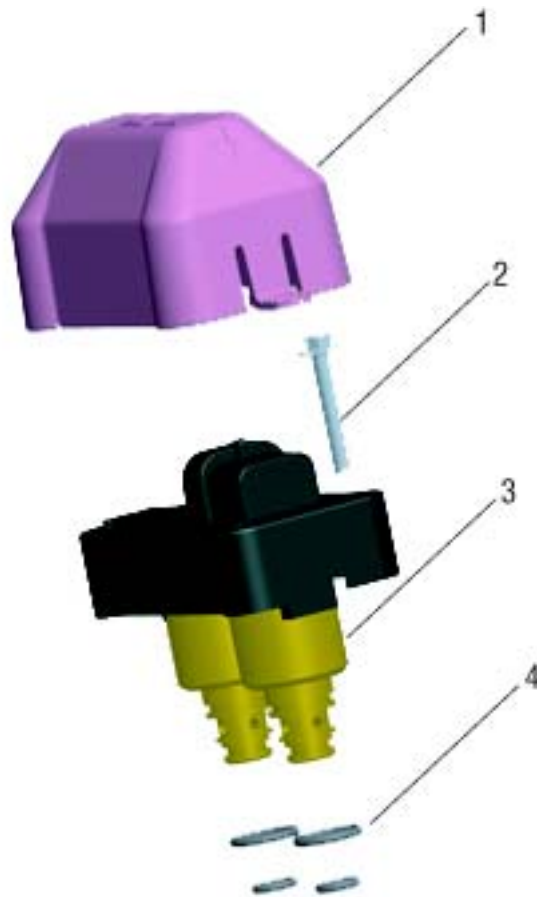

1. Protective Cover (Optional)
2. Cap Screw
3. Valve
4. O-rings

Procedure - Removal

1. If equipped, remove the Protective Cover by pulling up on the Release Tab.

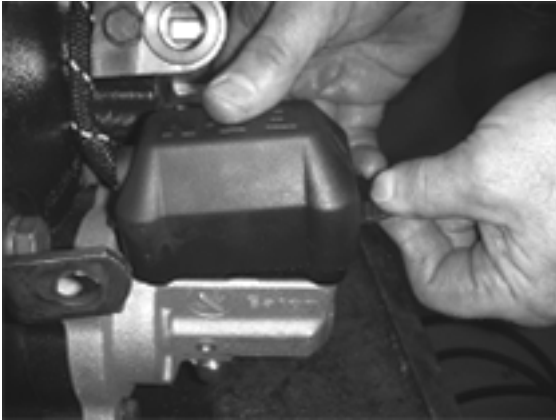

2. Relieve system air pressure by draining air tanks on the vehicle. When air pressure has been relieved, disconnect the Transmission Harness from the Range Valve.

Note: The harness should be removed from the Range Valve tie-down prior to removing the cap screws.

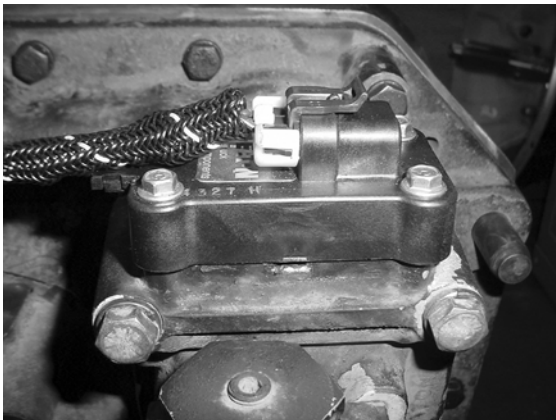

3. Using a 5/16" socket, remove the 4 mounting cap screws from the Range Valve.

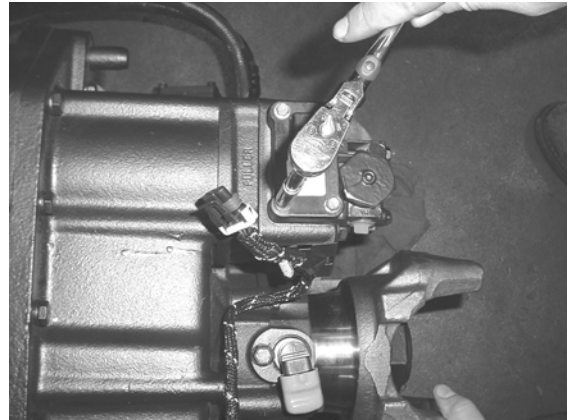

4. Lift and remove the Range Valve from the housing.



Caution: Do not use a hammer to loosen the Range Valve in the housing or it could be damaged.



Procedure - Installation

⚠ Important: Lubricate o-rings with Eaton Fuller silicone 71214 or equivalent.

⚠ Important: The valve is keyed to fit its mounting location. Take care to align the key with the notch in the housing.

1. Install and push the Range Valve down into the housing.



2. Using a 5/16" socket, install the 4 Range Valve mounting cap screws and tighten to 21-27 lb-in. (2.3-3.0 Nm) using a cross pattern.

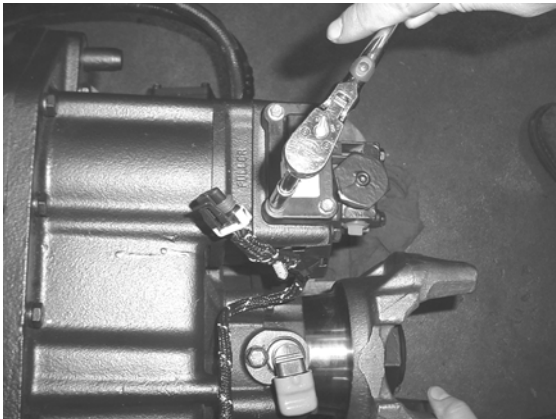

3. Reconnect the Transmission Harness to the Range Valve and close all air tanks drains.

Note: Install the Range Harness back into the tie-down on the Range Valve.

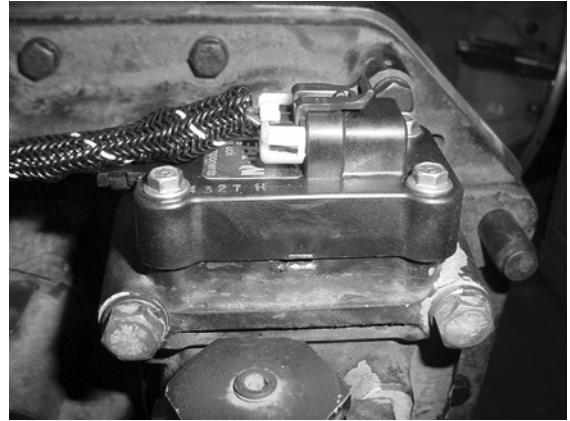

4. If equipped, install the Protective Cover. Push the cover down by hand until it snaps into place.

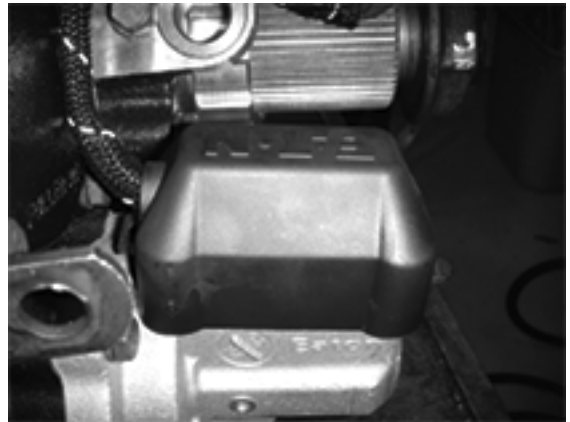

Splitter Valve

Special Instructions

The Splitter Valve may be difficult to remove from the housing because of the o-rings.

Special Tools

Basic hand tools

Component Identification

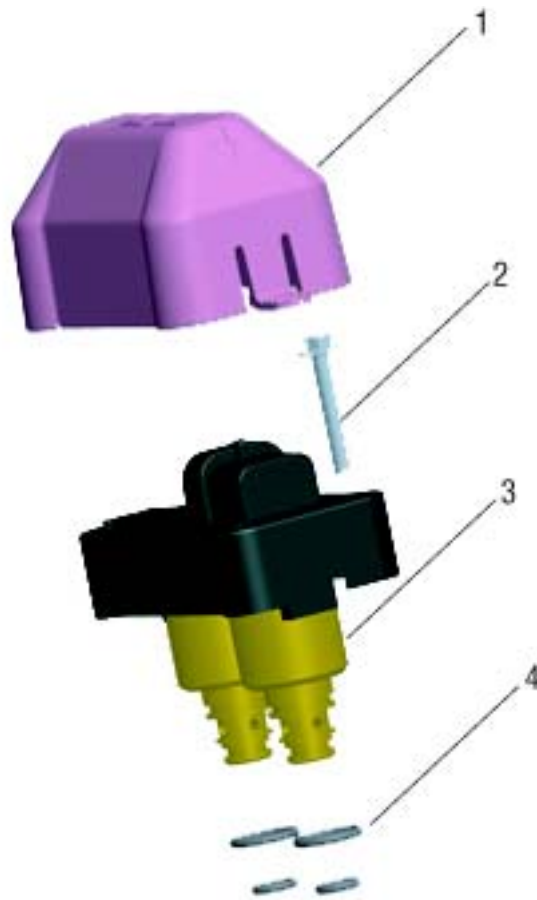

1. Protective Cover (Optional)
2. Cap Screw
3. Valve
4. O-rings

Procedure - Removal

1. If equipped, remove Protective Cover by pulling up on the Release Tab.

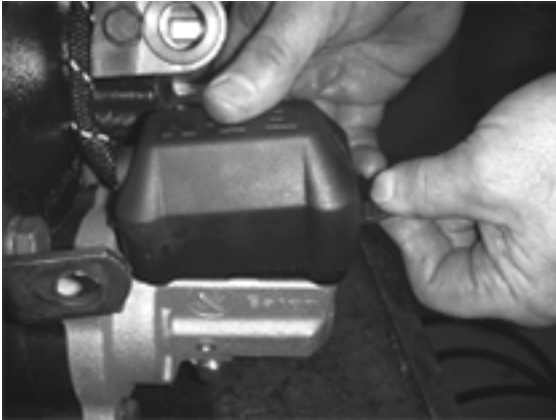

2. Relieve system air pressure by draining the air tanks on the vehicle. When air pressure is relieved, disconnect the Transmission Harness from the Splitter Valve assembly.

Note: The harness should be removed from the Splitter Valve tie-down, prior to removing the cap screws.

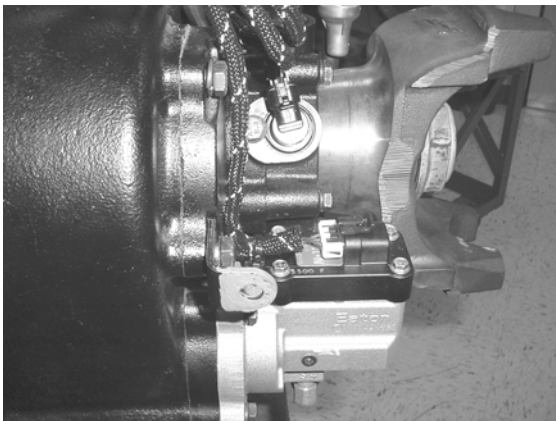

3. Using a 5/16" wrench, remove the 4 mounting cap screws from the Splitter Valve.

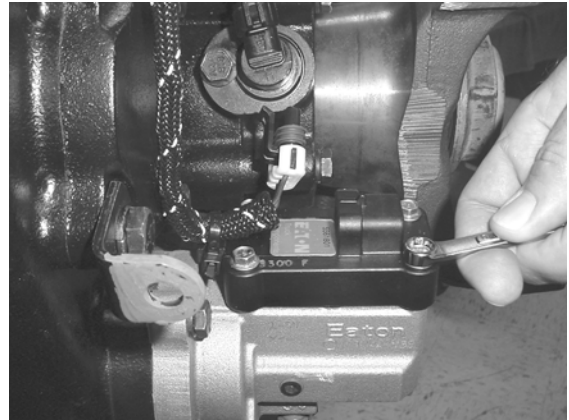

4. Lift and remove the Splitter Valve from the housing.



Caution: Do not use a hammer to loosen the Splitter Valve in the housing or it could be damaged.

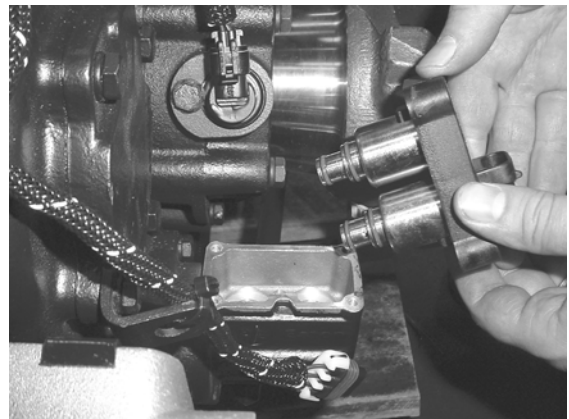

Procedure - Installation

 **Important:** Lubricate o-rings with Eaton Fuller silicone 71214 or equivalent.

 **Important:** The valve is keyed to fit its mounting location. Take care to align the key with the notch in the housing.

1. Install and push the Splitter Valve down into the housing.

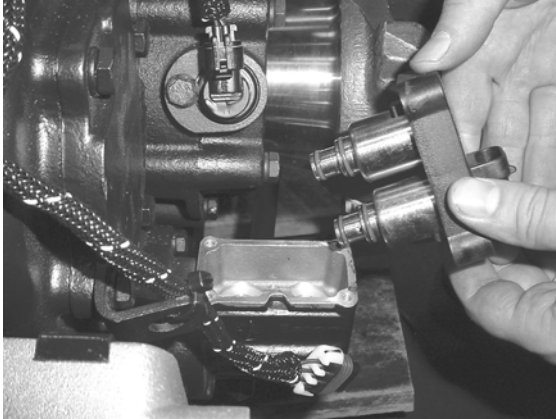

2. Using a 5/16" wrench, install the 4 mounting cap screws and tighten to 21-27 lb-in. (2.3-3.0 Nm) using a cross pattern.

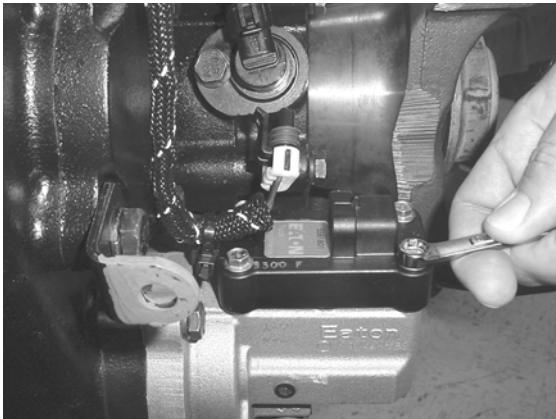

3. Reconnect the Transmission Harness to the Splitter Valve and close all air tank drains.

Note: Install the Splitter Harness back into the tie-down on the Splitter Valve.

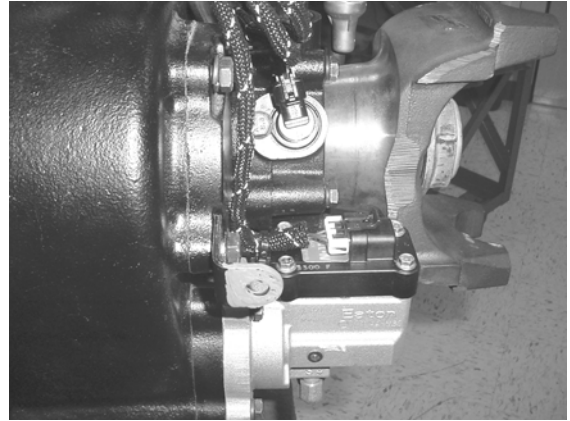

4. If equipped, install the Protective Cover. Push the cover down by hand until it snaps into place.



Directional Output Shaft Speed Sensor

Special Instructions

The Directional Output Shaft Speed Sensor is used on the Fuller® UltraShift® *PLUS* model transmissions. The Output Shaft Speed Sensor location may vary depending on OEM design specifications. The sensor will be located at 10 o'clock on the Output Shaft Housing in heavy-duty models and 12 o'clock on the Output Shaft Housing in medium-duty models.

Special Tools

Basic hand tools

Component Identification

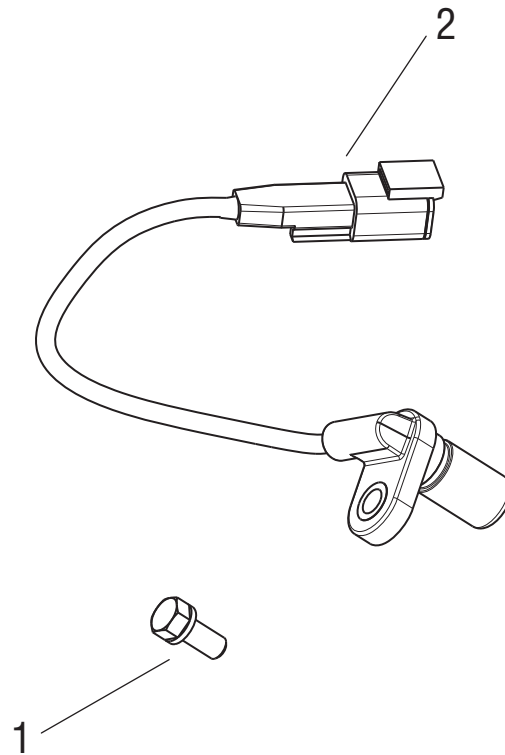

- 1. Cap Screw
- 2. Sensor with Harness

Procedure - Removal

1. Disconnect the Transmission Harness from the Output Shaft Speed Sensor Pigtail Connector.



3. Remove the Speed Sensor from the Transmission Rear Bearing Cover.

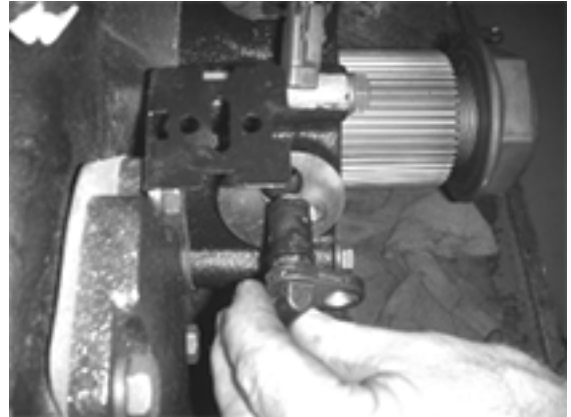

2. Remove the Sensor Retaining Bolt.



Procedure - Installation



Important: Lubricate Sensor with Eaton lubricant 5564527.

1. Using a smooth, twisting motion, fully insert the Output Shaft Speed Sensor in the transmission housing opening.

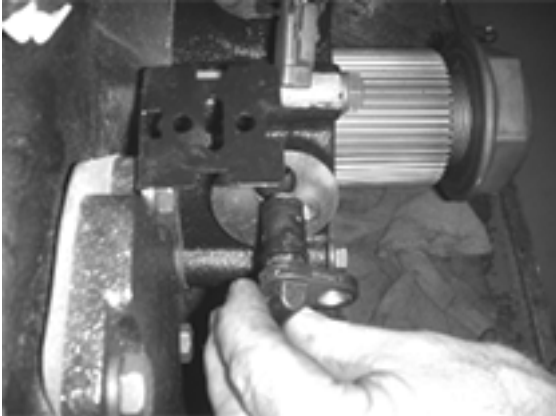

2. Install the Retaining Bolt and tighten to 8-10 lb-ft. (11-13 Nm).

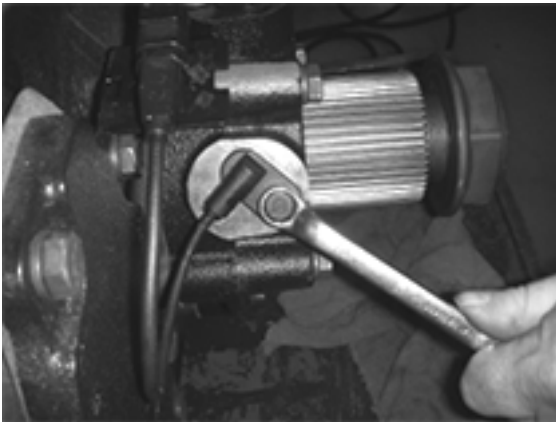

3. Apply included material to the Sensor Connector terminals.

Note: Apply just enough material to cover the end of the terminal.

Note: Use only Eaton lubricant 5564527. (Nye Lubricants NYOGEL 760G - For MSDS safety or other information see www.nyelubricants.com)

4. Reconnect the Transmission Harness to the Output Shaft Speed Sensor and install the tie-down.

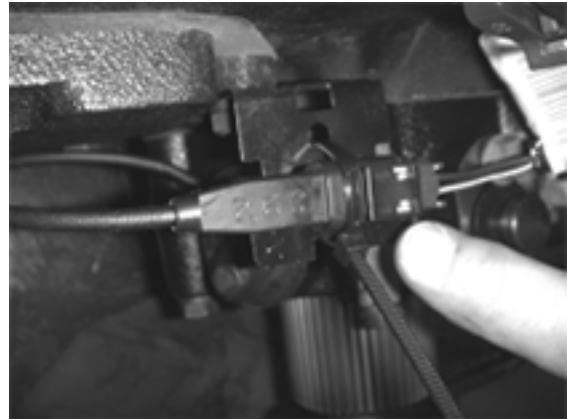

Park Actuator Assembly

Special Instructions

None

Special Tools

Basic hand tools

Component Identification

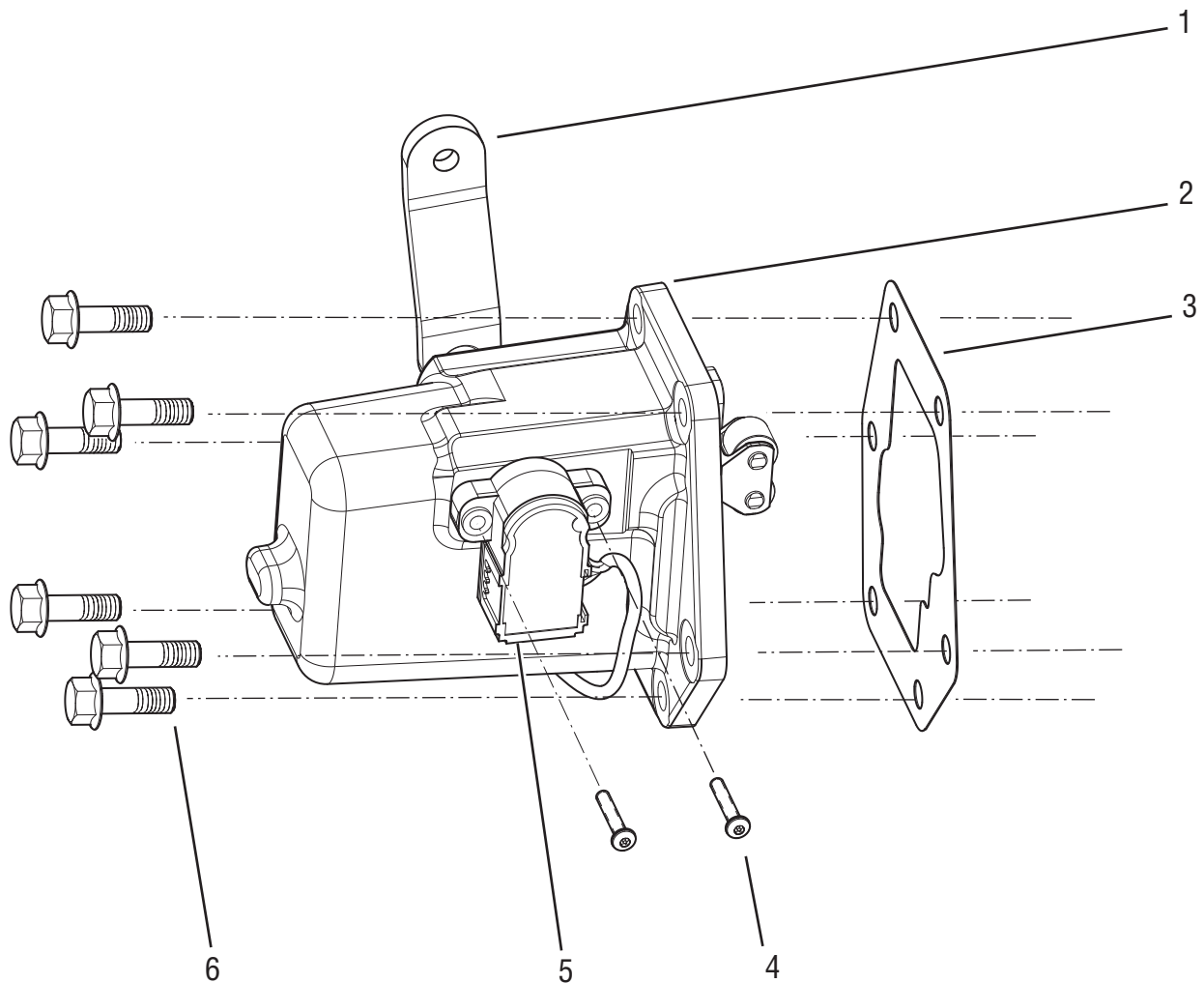

1. Shift Lever connection for OEM supplied Shift Cable
2. Park Actuator Assembly
3. Actuator Gasket
4. Sensor Fasteners (2)
5. Park Sensor
6. Actuator Fasteners (6)

Procedure - Removal

1. Remove Shift Cable from Actuator lever.
2. Unplug park sensor from vehicle harness.
3. Remove (6) actuator fasteners.
4. Remove actuator.

Procedure - Installation

1. Clean old gasket from transmission case and actuator housing.
2. Install new actuator gasket.
3. Install (6) actuator fasteners and torque to 30 - 35 lb-in.
4. Plug sensor into vehicle harness.
5. Re-attach the shift cable per OEM guidelines.
6. Calibrate sensor.

Park Pawl Position Sensor

Special Instructions

None

Special Tools

Basic hand tools

Component Identification

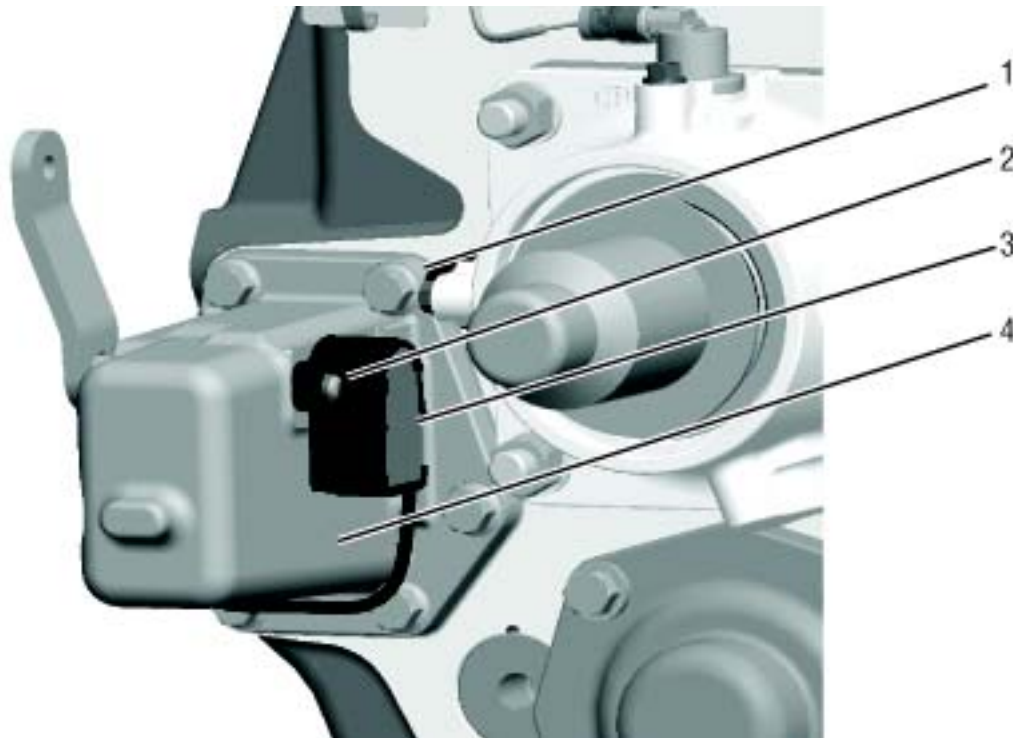

1. Actuator Fasteners (6)
2. Sensor Fasteners (2)
3. Park Sensor
4. Park Actuator Assembly

Procedure - Removal

1. Unplug Park Pawl Position Sensor from vehicle harness.
2. Remove the 2 sensor fasteners.
3. Remove Park Pawl Position Sensor.

Procedure - Installation

1. Install new sensor, aligning tab with groove in rod and rotating to mounting hole location.
2. Install 2 sensor fasteners and torque to 11-12 lb-in.
3. Plug Park Pawl Position Sensor into vehicle harness.
4. Calibrate.

Final Check

Park Sensor Calibration

Note: Sensors should be calibrated from the factory. This procedure should only be used if it is discovered that the calibrated and actual position sensor values do not correlate.

Note: Parking Brake must be set for this procedure to be performed.

1. Turn ignition off and wait for the XY calibration to complete.
2. Turn ignition on, but do not start the engine.
3. Depress accelerator fully and depress the brake pedal.
4. Key ignition off and on 3 times while maintaining the throttle and brake application.
5. Monitor the display; it should start to scroll CAL.
6. Release the throttle and brake.
7. The display will now guide you through the calibration procedure.
8. The display will show a (1) in both digits of the display. The right digit will be flashing.

Medium-Duty Output Shaft Speed Sensor

Special Instructions

The Output Shaft Speed Sensor location may vary depending on OEM design specifications. The sensor will be located at 10 o'clock on the Output Shaft Housing on the heavy-duty model and at 12 o'clock on the Output Shaft Housing for medium-duty model.

Special Tools

Basic hand tools

Component Identification

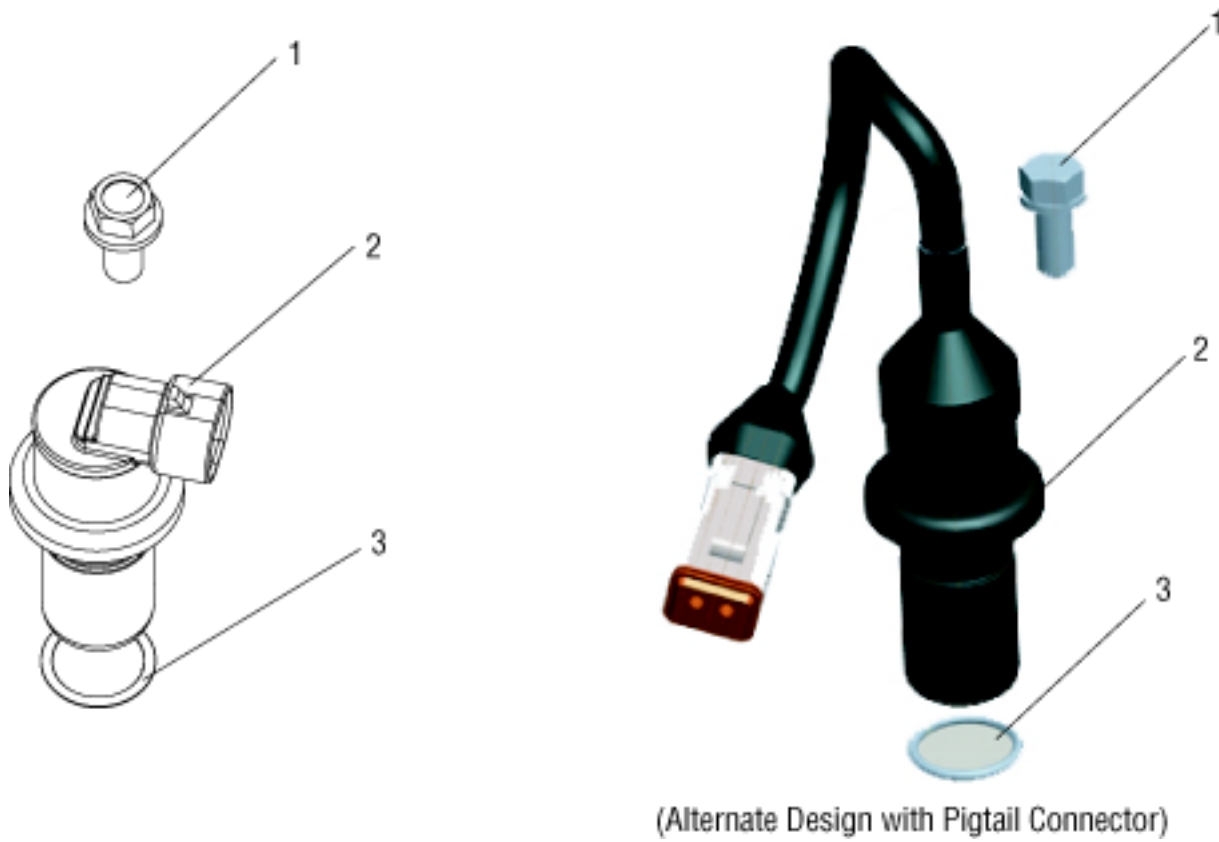

1. Cap Screw
2. Sensor
3. O-ring

Procedure - Removal

1. Disconnect the Transmission Harness from the Output Shaft Speed Sensor or Pigtail Connector, if equipped.

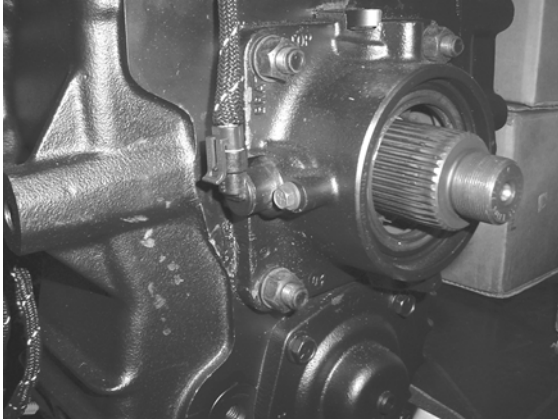

3. Remove the Output Shaft Speed Sensor, with o-ring, from the transmission housing.

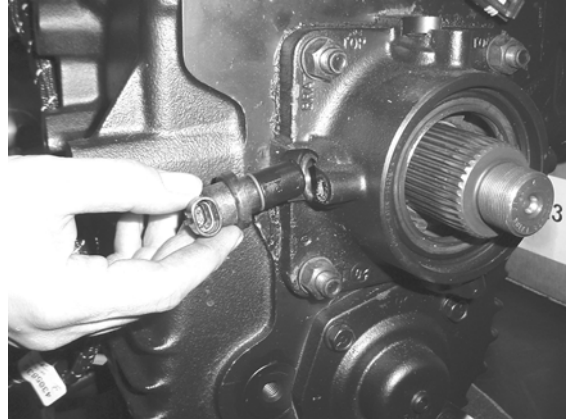

2. Using a 3/8" socket, remove the sensor retaining bolt.

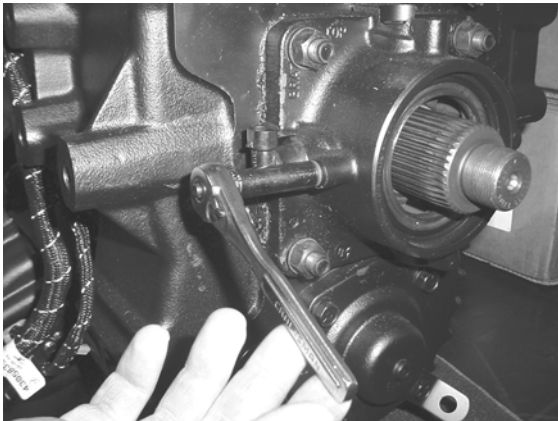

Procedure - Installation



Important: Clean the mounting surface on the housing and remove any burrs or sharp edges.



Important: Lubricate the o-ring with Eaton Fuller silicone 71214 or equivalent.

1. Using a smooth, twisting motion, fully insert the Output Shaft Speed Sensor in the transmission housing opening.

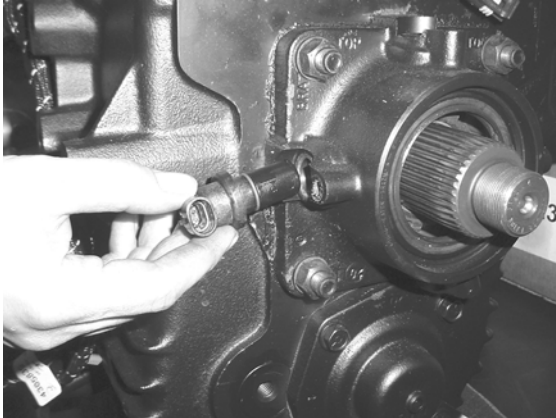

2. Using a 3/8" socket, install the retaining bolt and tighten to 8-10 lb-ft. (11-13 Nm).

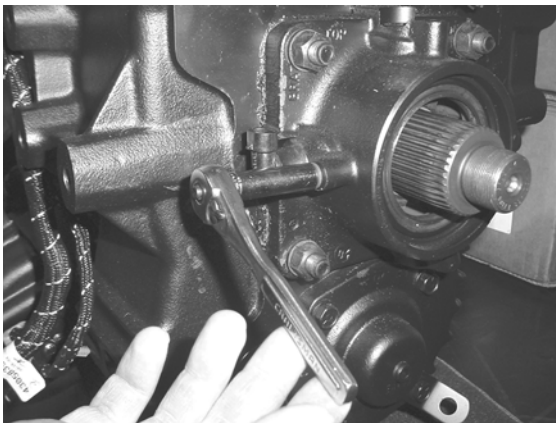

3. Reconnect the Transmission Harness to the Output Shaft Speed Sensor or Pigtail Connector, if equipped.

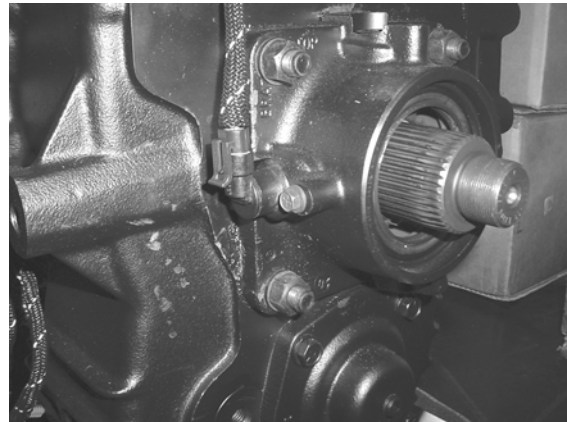

Heavy-Duty Output Shaft Speed Sensor

Special Instructions

The Output Shaft Speed Sensor location may vary depending on OEM design specifications. The sensor will be located at 10 o'clock on the Output Shaft Housing in the heavy-duty model and 12 o'clock on the Output Shaft Housing for medium-duty model.

Component Identification

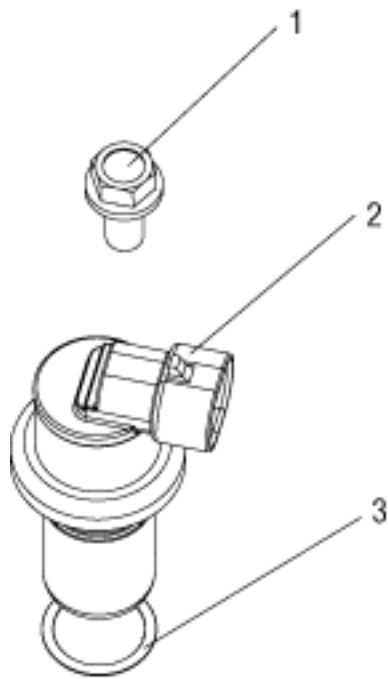

Special Tools

Basic hand tools



(Alternate Design with Pigtail Connector)

1. Cap Screw
2. Sensor
3. O-ring

Procedure - Removal

1. Disconnect the Transmission Harness from the Output Shaft Speed Sensor or Pigtail Connector, if equipped.

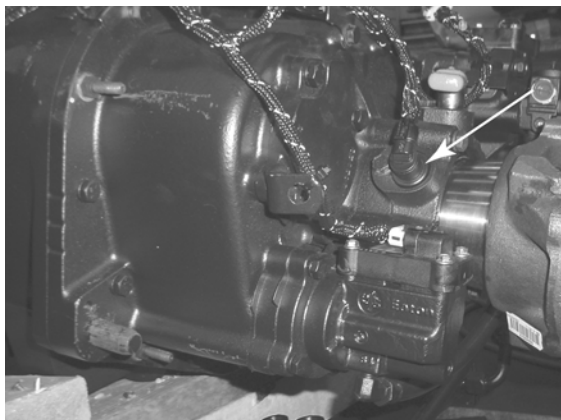

3. Remove the Output Shaft Speed Sensor, with o-ring, from the transmission housing.

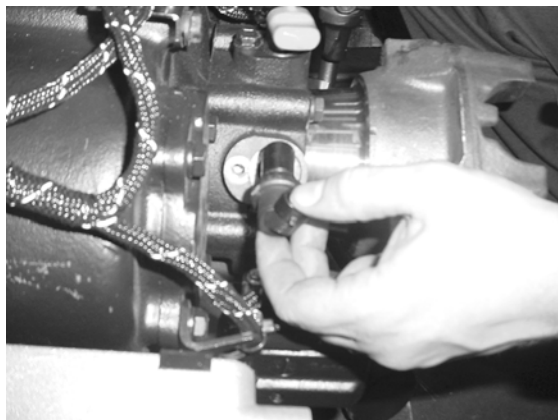

2. Using a 13 mm socket, remove the sensor retaining bolt.



Procedure - Installation

 **Important:** Clean the mounting surface on the housing and remove any burrs or sharp edges.

 **Important:** Lubricate the o-ring with Eaton Fuller silicone 71214 or equivalent.

1. Using a smooth, twisting motion, fully insert the Output Shaft Speed Sensor in the transmission housing opening.



2. Using a 13 mm socket, install the retaining bolt and tighten to 15-19 lb-ft. (20-25 Nm).

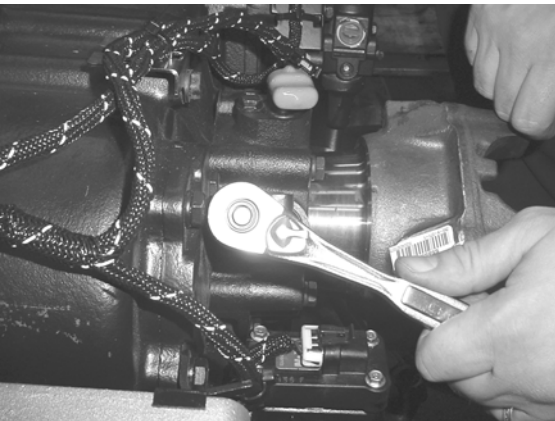

3. Reconnect the Transmission Harness to the Output Shaft Speed Sensor or Pigtail Connector, if equipped.

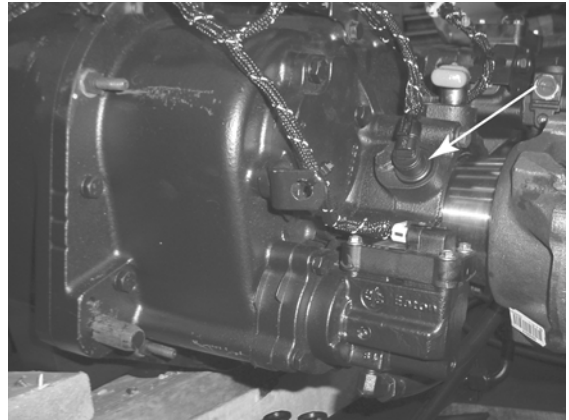

Main Shaft Speed Sensor

Special Instructions

None

Special Tools

Basic hand tools

Component Identification

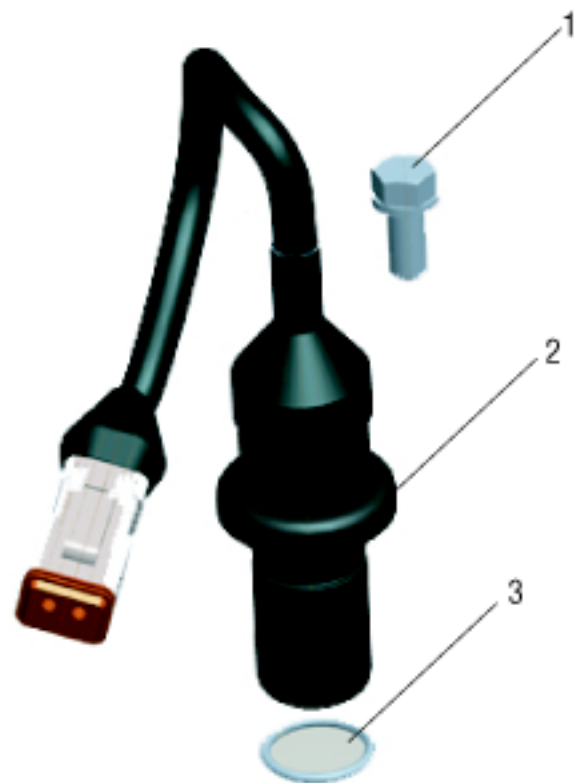
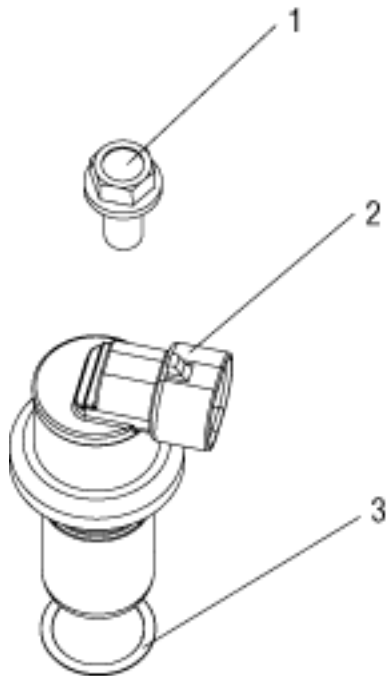

(Alternate Design with Pigtail Connector)

- 1. Cap Screw
- 2. Sensor
- 3. O-ring

Procedure - Removal

1. Disconnect the Transmission Harness from the Main Shaft Speed Sensor or Pigtail Connector, if equipped.
3. Remove the Main Shaft Speed Sensor, with o-ring, from the transmission housing.

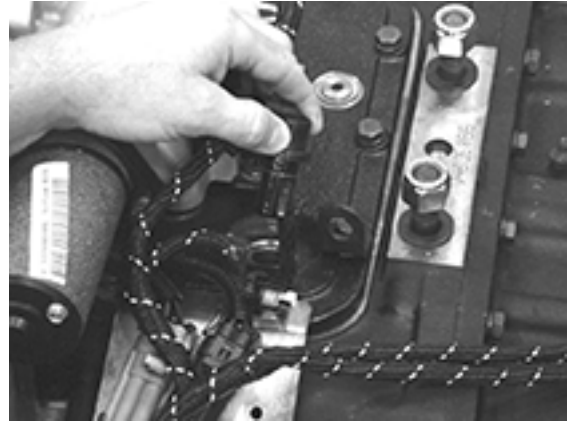
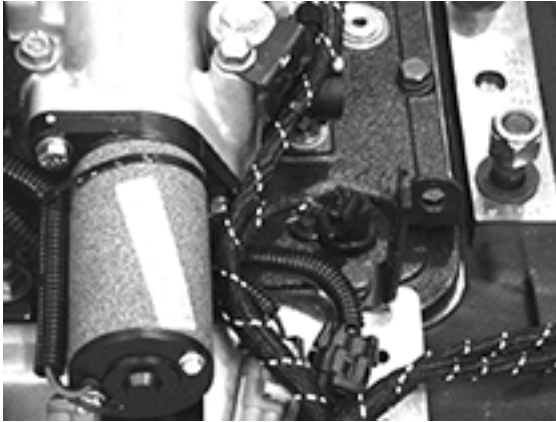

2. Using a 3/8" socket, remove the sensor retaining bolt.

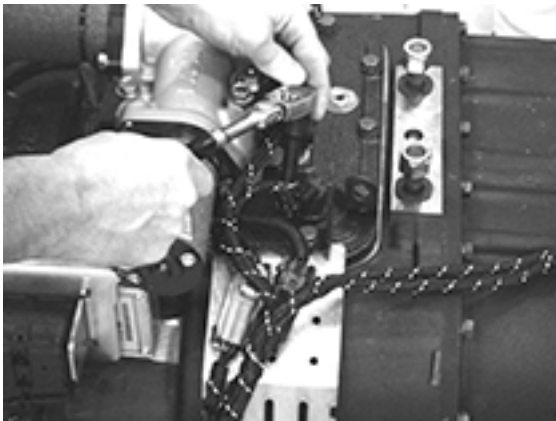

Procedure - Installation

 **Important:** Clean the mounting surface on the housing and remove any burrs or sharp edges.

 **Important:** Lubricate the o-ring with Eaton Fuller silicone 71214 or equivalent.

1. Using a smooth, twisting motion, fully insert the Main Shaft Speed Sensor in the transmission housing opening.

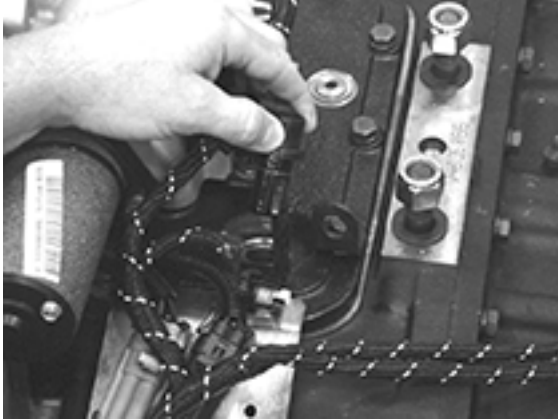

2. Using a 3/8" socket, install the retaining bolt and tighten to 8-10 lb-ft. (11-13 Nm).

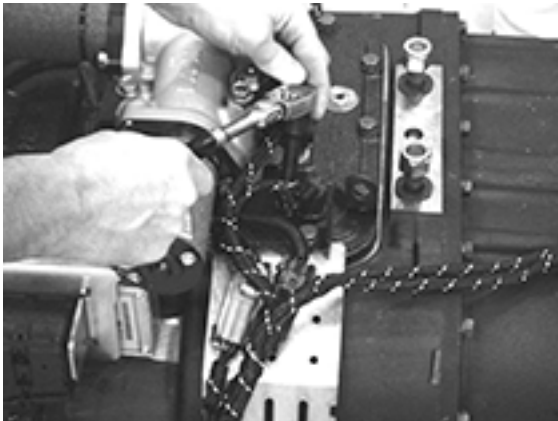

3. Reconnect the Transmission Harness to the Main Shaft Speed Sensor or Pigtail Connector, if equipped.

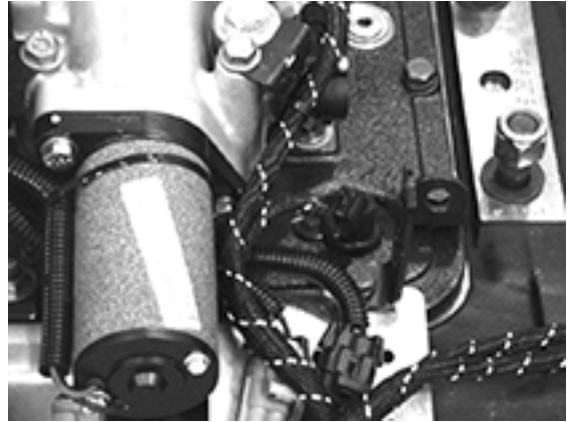

Medium-Duty Input Shaft Speed Sensor

Special Instructions

Input Shaft Speed Sensor location varies as follows:

- Medium-Duty: Top of Inertia Brake
- Heavy-Duty: Right front of Shift Bar Housing

Special Tools

Basic hand tools

Component Identification

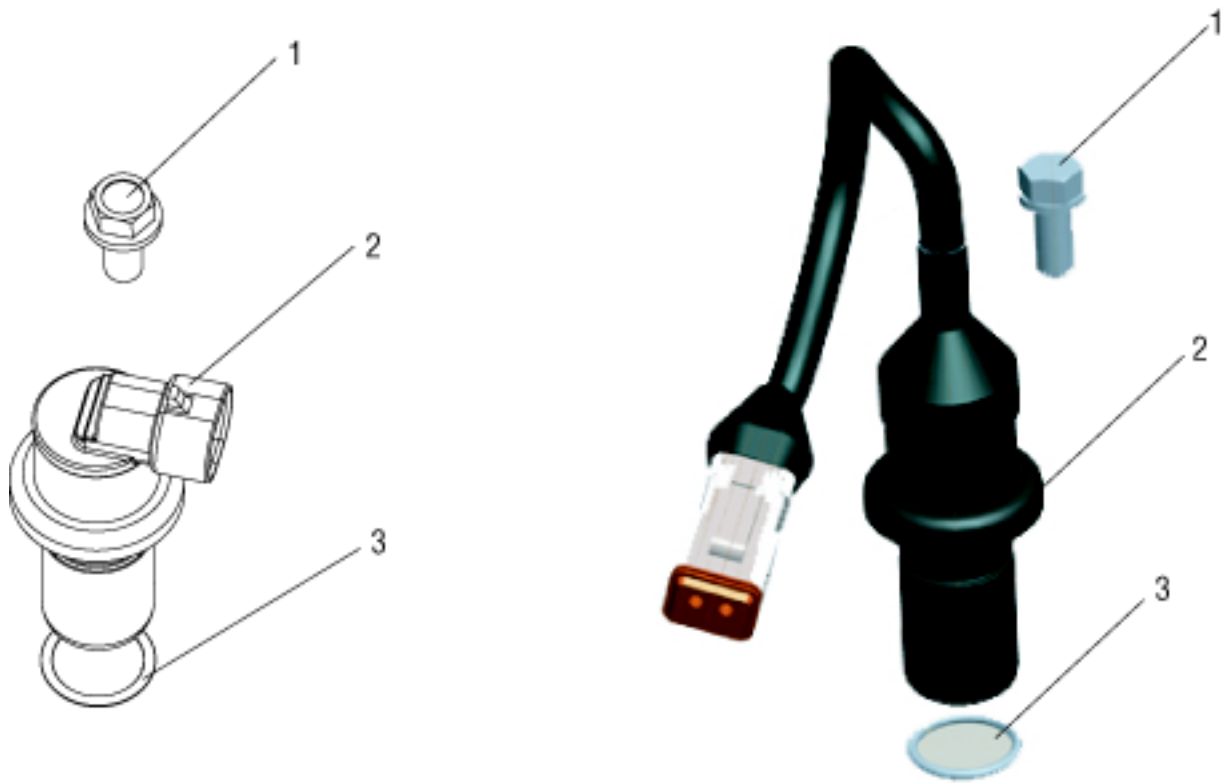

(Alternate Design with Pigtail Connector)

1. Cap Screw
2. Sensor
3. O-ring

Procedure - Removal

1. Disconnect the Transmission Harness from the Input Shaft Speed Sensor.

Note: Drain the lubricant before removing the sensor.

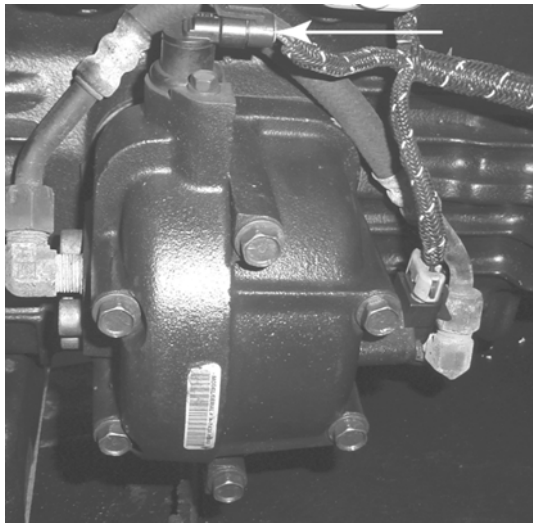

3. Remove the Input Shaft Speed Sensor, with o-ring, from the transmission housing.

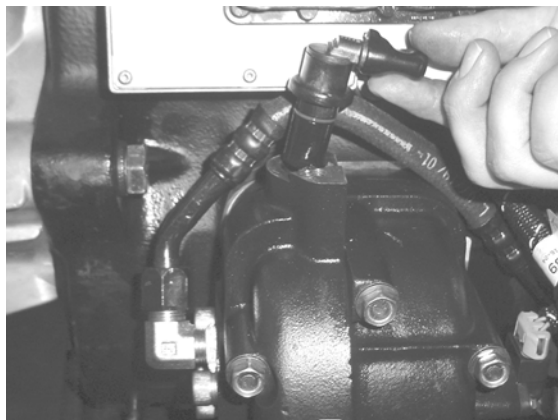

2. Using a 3/8" wrench, remove the sensor retaining bolt.



Procedure - Installation

 **Important:** Clean the mounting surface on the housing and remove any burrs or sharp edges.

 **Important:** Lubricate the o-ring with Eaton Fuller silicone 71214 or equivalent.

1. Using a smooth, twisting motion, fully insert the Input Shaft Speed Sensor in the Inertia Brake opening.

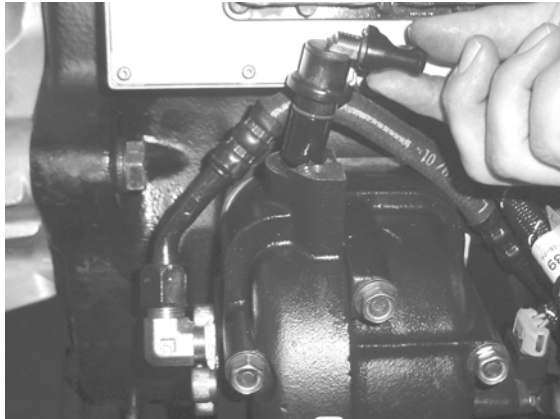

2. Using a 3/8" wrench, install the sensor retaining bolt and tighten to 8-10 lb-ft. (11-13 Nm).



3. Reconnect the Transmission Harness to the Input Shaft Speed Sensor.

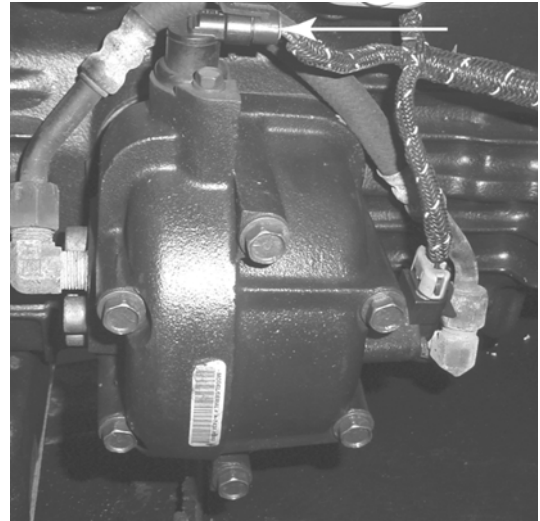

4. Fill the transmission with lubricant. See "Lubrication Specifications" on page 141.

Heavy-Duty Input Shaft Speed Sensor

Special Instructions

Input Shaft Speed Sensor location varies as follows:

- Medium-Duty: Top of Inertia Brake
- Heavy-Duty: Right front of Shift Bar Housing

Component Identification

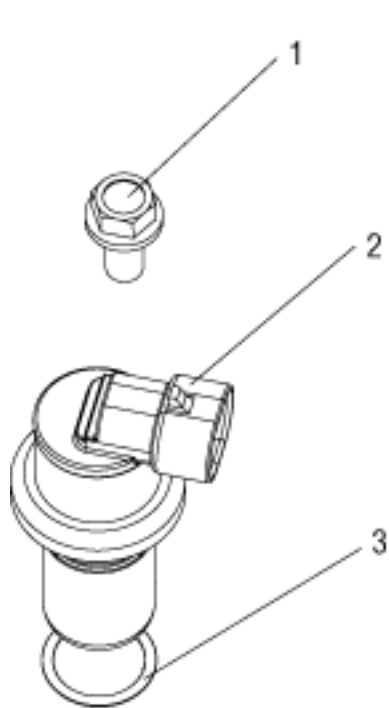

Special Tools

Basic hand tools



(Alternate Design with Pigtail Connector)

1. Cap Screw
2. Sensor
3. O-ring

Procedure - Removal

1. Disconnect the Transmission Harness from the Input Shaft Speed Sensor or Pigtail Connector, if equipped.
3. Remove the Input Shaft Speed Sensor, with o-ring, from the transmission housing.

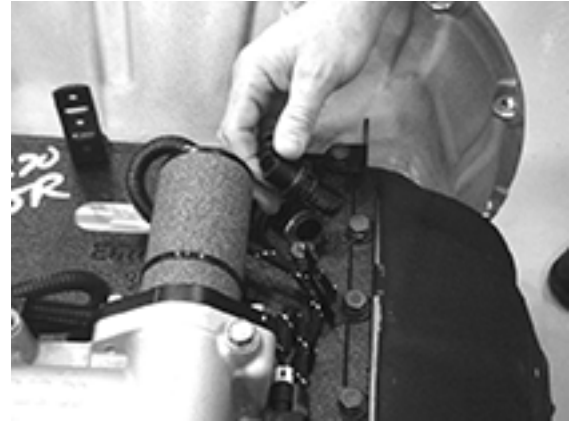
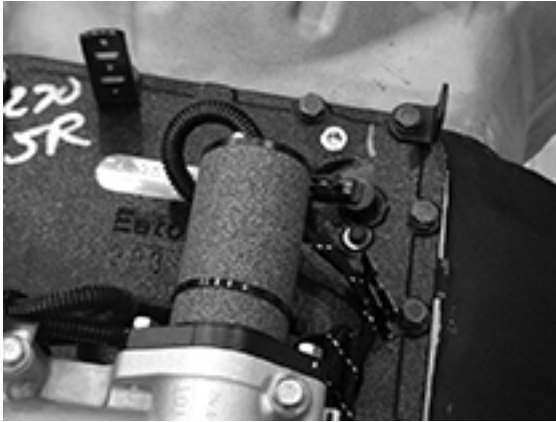

2. Using a 3/8" socket, remove the sensor retaining bolt.

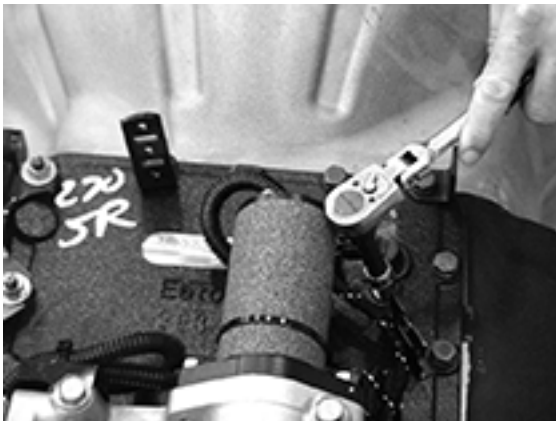

Procedure - Installation

 **Important:** Clean the mounting surface on the housing and remove any burrs or sharp edges.

 **Important:** Lubricate the o-ring with Eaton Fuller silicone 71214 or equivalent.

1. Using a smooth, twisting motion, fully insert the Input Shaft Speed Sensor in the transmission housing opening.



2. Using a 3/8" socket, install the retaining bolt and tighten to 8-10 lb-ft. (11-13 Nm).

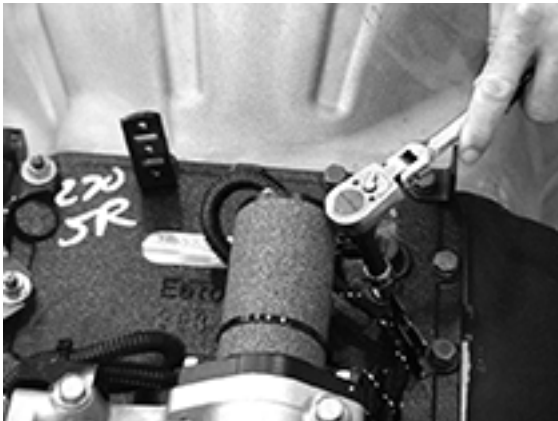

3. Reconnect the Transmission Harness to the Input Shaft Speed Sensor or Pigtail Connector, if equipped.



Rail Select Sensor

Special Instructions

None

Special Tools

Basic hand tools

Component Identification

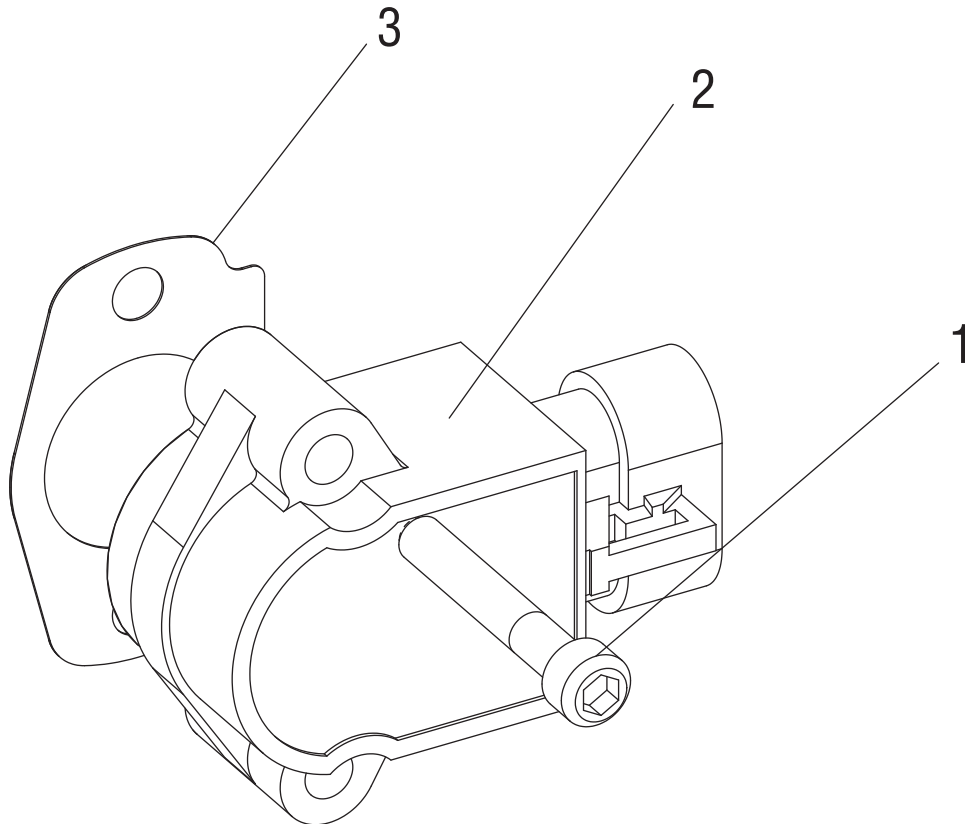

- 1. Cap Screw
- 2. Sensor
- 3. Gasket

Procedure - Removal

1. Disconnect the Transmission Harness from the Rail Select Sensor.

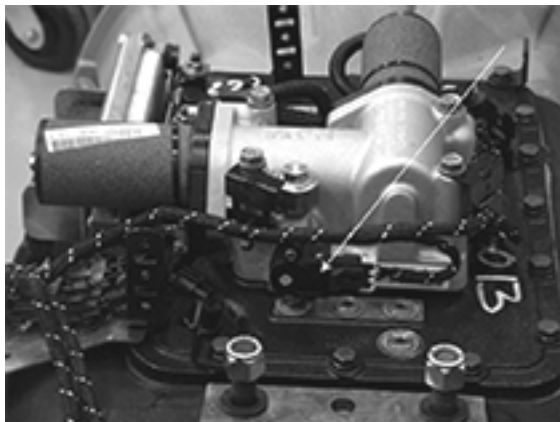

3. Remove the Rail Select Sensor and gasket from the housing.

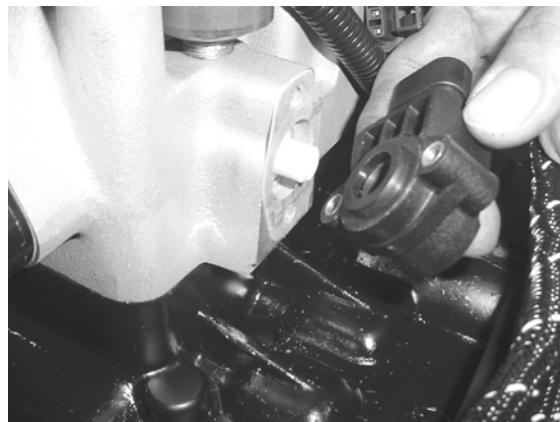

2. Using a 5/32" hex key wrench, remove the 2 sensor hex key mounting screws.



Caution: Carefully allow the sensor to rotate to a relaxed position, or the sensor can snap when the hex key mounting screws are removed.

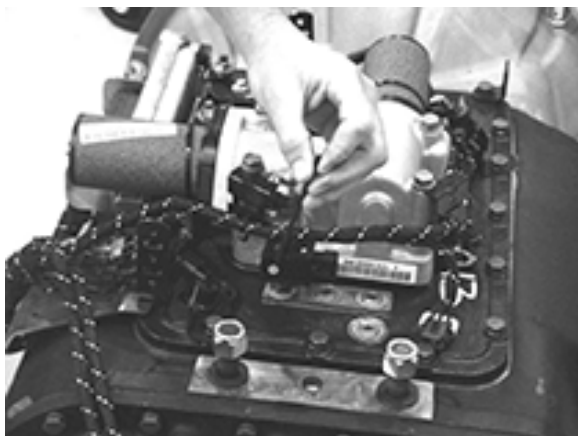

Procedure - Installation

1. Align sensor tabs with the slot in the Electric Shifter rail. Then, insert the Rail Select Sensor, with gasket, into its mounting location.

Note: Install the sensor, so connector opening faces right side of the transmission. (As viewed from the rear of the transmission)

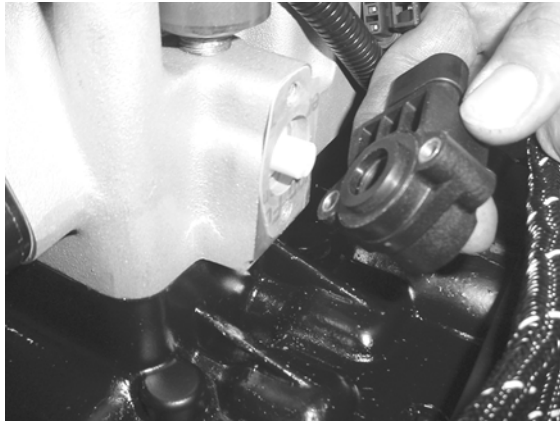

2. Using a 5/32" hex key wrench, install the 2 hex key mounting screws and tighten to 21-27 lb-in. (2.3-3.0 Nm).



Caution: Carefully hold sensor in position while installing the hex key mounting screws, or sensor can snap.



3. Reconnect the Transmission Harness to the Rail Select Sensor.

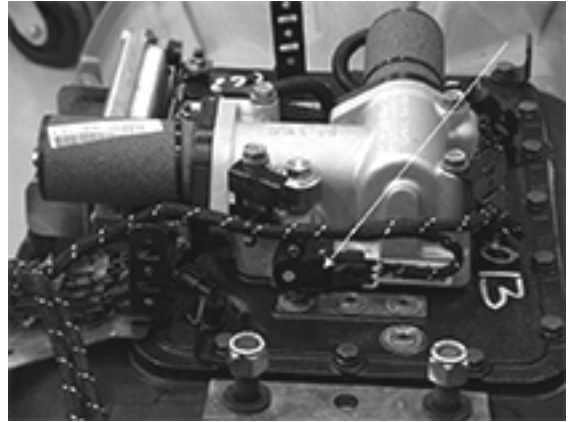

Gear Select Sensor

Special Instructions

None

Special Tools

Basic hand tools

Component Identification

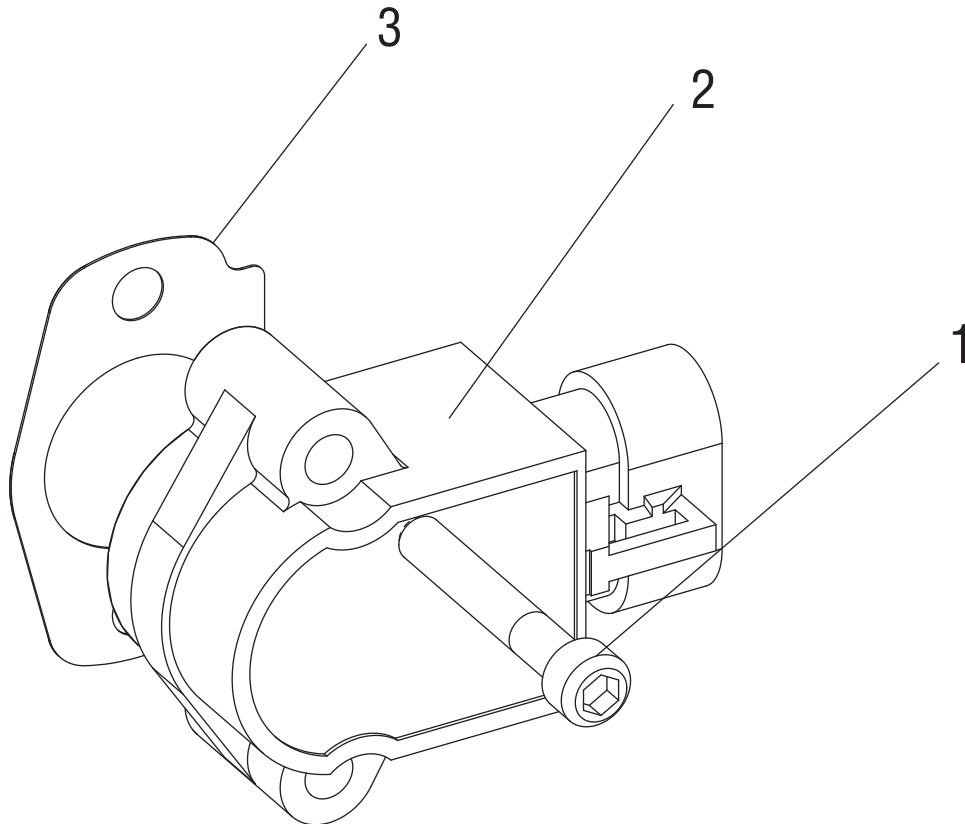

- 1. Cap Screw
- 2. Sensor
- 3. Gasket

Procedure - Removal

1. Disconnect the Transmission Harness from the Gear Select Sensor.

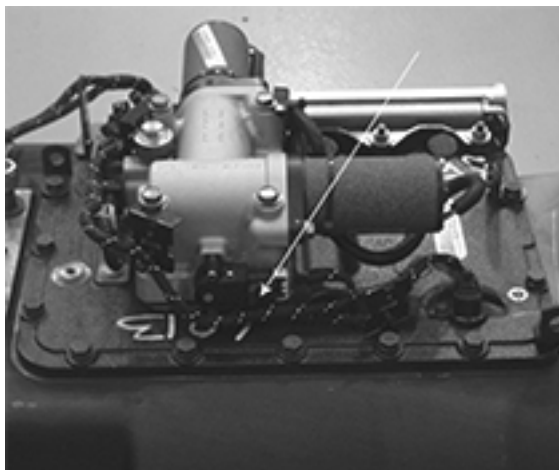

3. Remove the Gear Select Sensor and gasket from the housing.

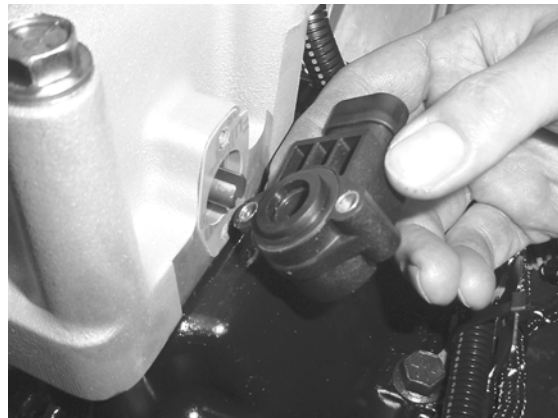

2. Using a 5/32" hex key wrench, remove the two (2) sensor hex key mounting screws.



Caution: Carefully allow sensor to rotate to a relaxed position, or sensor can snap when the hex key mounting screws are removed.

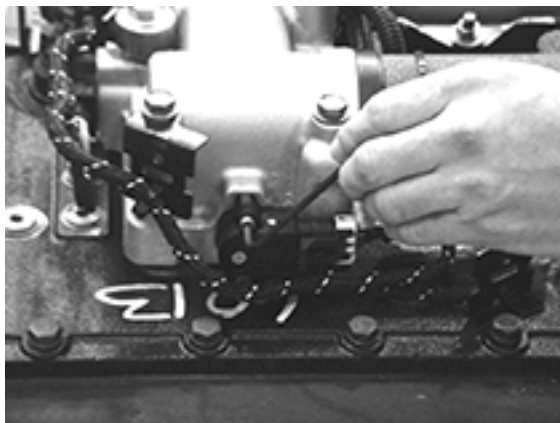

Procedure - Installation

1. Align the sensor tabs with the slots in the Electric Shifter Rail. Then, insert Gear Select Sensor, with gasket, into its mounting location.

Note: Install sensor so the connector opening faces the front of the transmission.

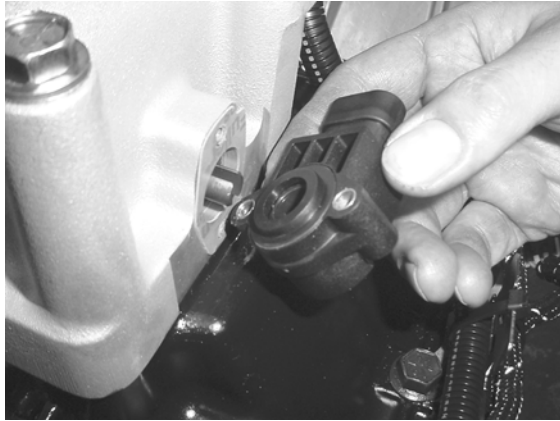

2. Using a 5/32" hex key wrench, install the hex key mounting screws and tighten to 21-27 lb-in. (2.3-3.0 Nm).



Caution: Carefully hold sensor in position while installing hex key mounting screws, or sensor can snap.

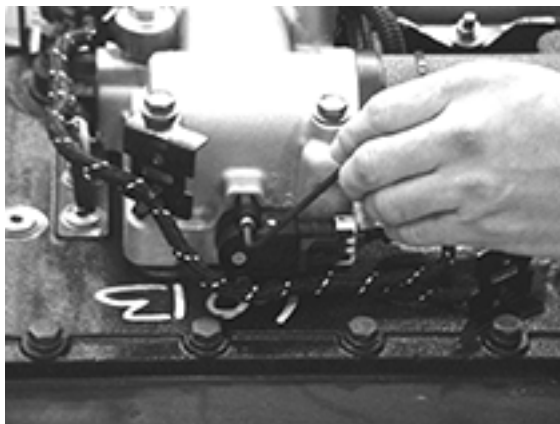

3. Reconnect the Transmission Harness to the Gear Select Sensor.

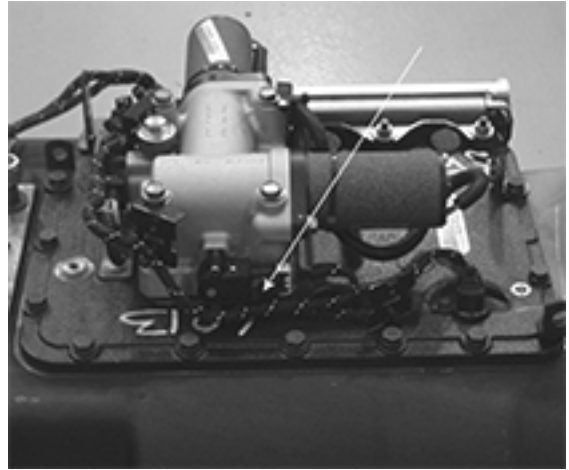

Lubricant Filter (AW3 Models Only)

Special Instructions

Transmission filters should be changed during regular lubrication intervals.

Inspection of the transmission filter should be conducted during preventative maintenance checks for damage or corrosion. Replace as necessary.

Special Tools

Basic hand tools

Component Identification

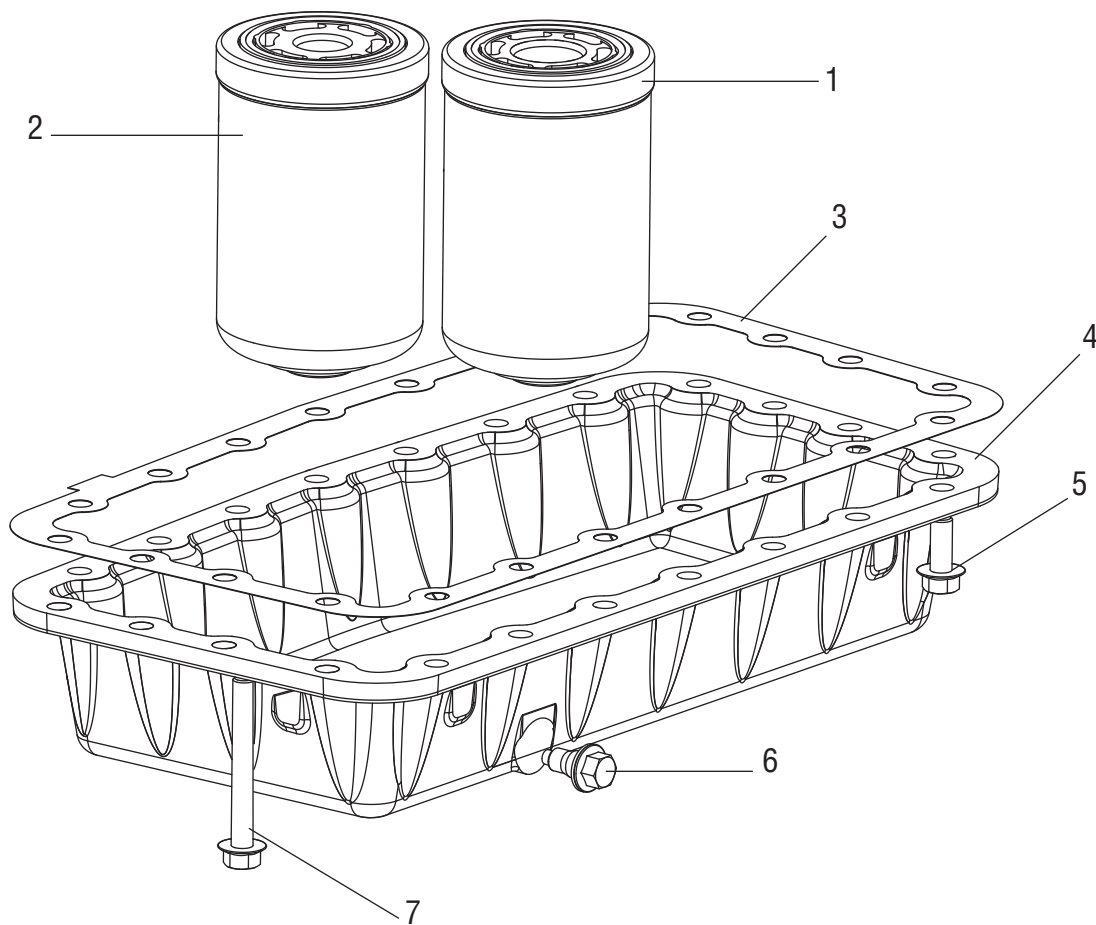

1. High Pressure Oil Filter (Large opening)
2. Low Pressure Oil Filter (Small opening)
3. Gasket
4. Oil Pan
5. Short Cap Screw
6. Long Cap Screw
7. Drain Plug

Procedure - Removal

1. Remove Drain Plug and drain fluid from the wet clutch portion of the transmission.



Warning: Fluid may be hot.

Note: Clean filter seal mating surfaces on the transmission.

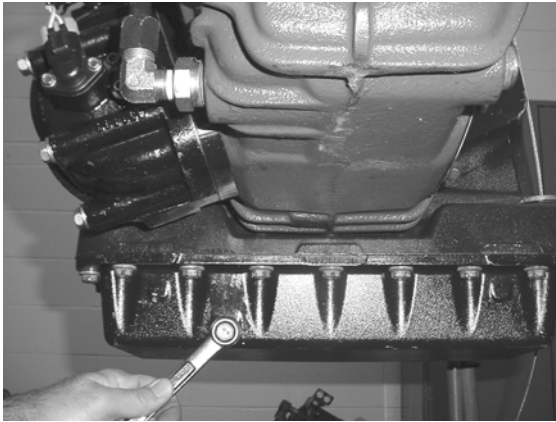

2. Using a 15mm socket, remove the Oil Pan Mounting bolts. Record location of the long and short bolts.



3. Remove the wet clutch oil pan and gasket.

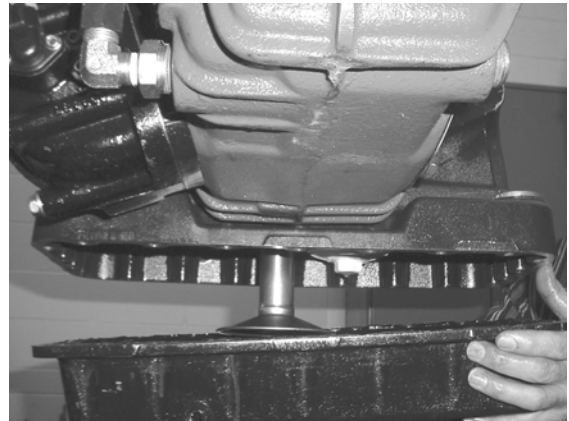

4. Using a 1/2" drive at the filter base, remove the 2 wet clutch filters. Make sure filter seals are removed.

Note: The filters will contain fluid when they are removed.

Note: Clean and remove all old gasket material from the mating surfaces of the clutch housing and oil pan.



Procedure - Installation

1. Install the high-pressure filter with a 1/2" drive and tighten to 25-30 lb-ft. (34-41 Nm).

Note: Lubricate each filter seal ring with synthetic Dexron III prior to installation.

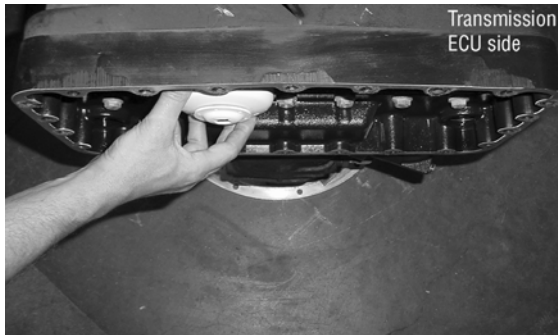

2. Install the low-pressure filter by hand and turn until the seal touches. Then, tighten with a 1/2" drive 3/4 to 1 full turn.

Note: High and low pressure filters are not interchangeable.



3. Install new gasket and wet clutch oil pan.

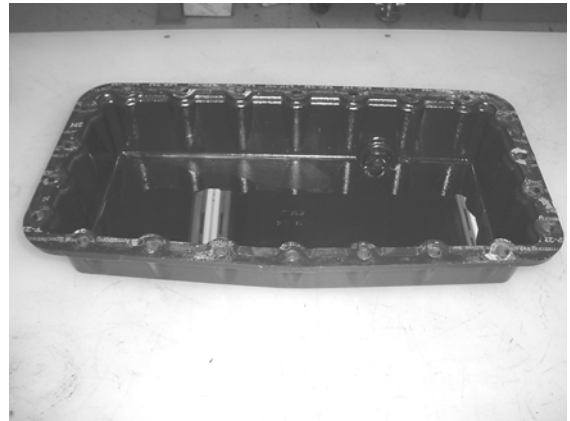

4. Using 15mm socket, install the mounting bolts and tighten to 30-35 lb-ft. (41-47 Nm) using a cross pattern.



Caution: Make sure to put long and short bolts back in their proper location to avoid damaging the transmission. Short bolts are used in the back of the oil pan.

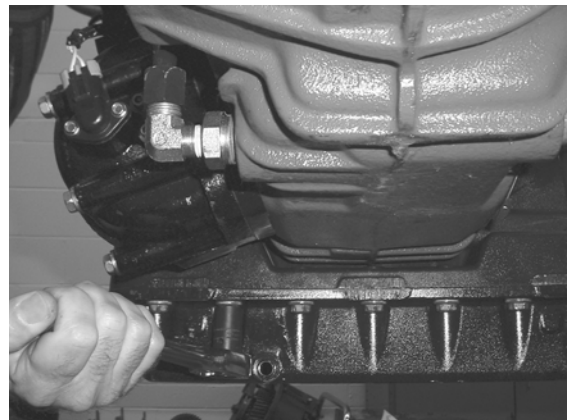

5. Install oil pan drain plug and tighten to 34-48 lb-ft. (46-64 Nm).

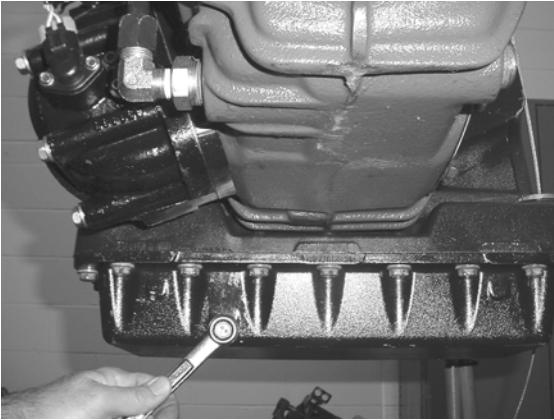

6. Fill the wet clutch portion with proper fluid, see "Lubrication Specifications" on page 141.

Operation and Basic Troubleshooting

Operation

For more detailed information on transmission operation and shifting, go to the Roadranger Literature Center (www.roadranger.com) and look for the “Driver’s Manual” on your transmission model.

- Generation 3 UltraShift Driver Instructions - TRDR0940
- Generation 3 AutoShift Driver Instructions - TRDR0930
- Driver Instructions for Fuller® UltraShift® PLUS models - TRDR1110

Basic Troubleshooting

For all Basic Troubleshooting questions refer to the appropriate service manual covering the base box procedures. These manuals can be found on Roadranger.com under the Literature Center.

Air System Operation and Troubleshooting

For all air system operation and troubleshooting questions refer to the “Eaton Gen III Automated Transmissions Troubleshooting Guide” TRTS0930, which is found on Roadranger.com under the Literature Center.

Inspection Procedures

For all inspection procedures on assembly and disassembly refer to the service manual covering the base box procedures. These manuals can be found in the Literature Center Roadranger.com.

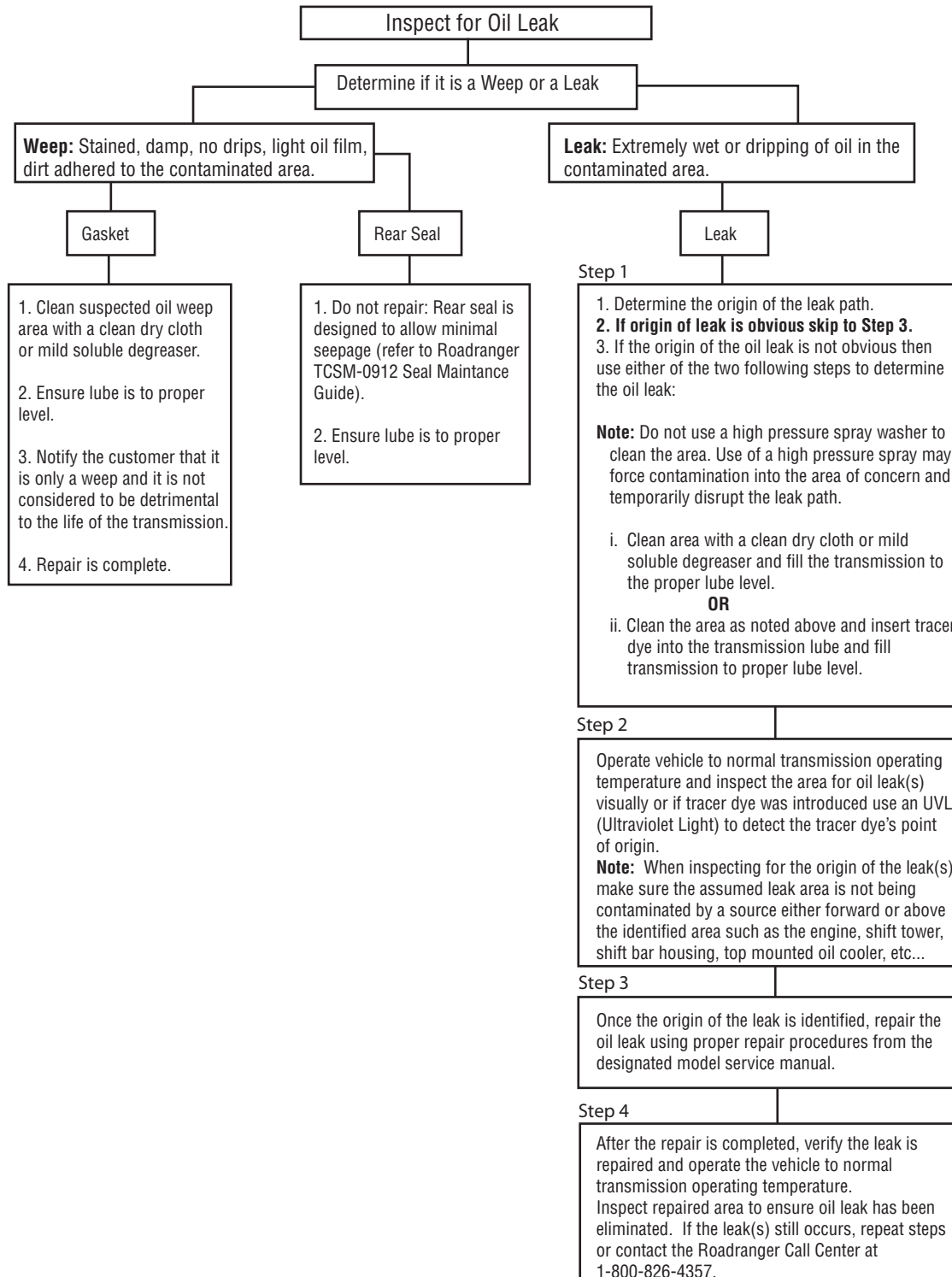

Lubrication Specifications

UltraShift DM3 and AutoShift AS3



Caution: Do not introduce additives and friction modifiers.



Caution: Never mix standard oils and synthetic transmission oils in the same transmission. When switching between types of lubricants, all areas of each affected component must be thoroughly drained.



Caution: Do not mix lubricants of different grades.

Note: For a list of Eaton Approved Synthetic Lubricants, see TCMT0021 or call 1-800-826-HELP (4357).

Note: The use of lubricants not meeting these requirements will affect warranty coverage.

Note: For lubrication change and inspection intervals see TCMT0021.

Note: Please refer to CLSM0200 for clutch lubrication and service guidelines.

Buy From a Reputable Dealer

For a complete list of approved and reputable dealers, write to: Eaton Corporation, Worldwide Marketing Services, P.O. Box 4013, Kalamazoo, MI 49003

Transmission Operating Angles

If the transmission operating angle is more than 12°, improper lubrication will occur. The operating angle is the transmission mounting angle in the chassis plus the percent of upgrade (expressed in degrees). For operating angles over 12°, the transmission must be equipped with an oil pump or cooler kit to insure proper lubrication.

Transmission filters should be changed during regular lubrication intervals. Inspection of the transmission filter should be conducted during preventative maintenance checks for damage or corrosion. Replace as necessary.

Operating Temperatures with Oil Coolers

Transmissions must not be operated at temperatures above 250°F (121°C). Operation at temperatures above this limit causes loaded gear tooth temperatures to exceed 350°F (177°C) which will ultimately destroy the heat treatment of the gears. If the elevated temperature is associated with an operating condition that will recur, a cooler should be added, or the capacity of the existing cooling system increased.

The following conditions, in any combination, can cause operating temperatures of over 250°F (120°C):

- Operating consistently at high loads/slow speeds
- High ambient temperatures
- Restricted air flow around the transmission
- Exhaust system too close to the transmission
- High horsepower operation
- Engine retarders

External oil coolers are available to reduce operating temperatures when the above conditions are encountered. Eaton oil cooler systems must meet a minimum requirement of 3/4" ID cooler lines and 8 GPM system flow at 1500 RPM. The end user is ultimately responsible for maintaining transmission lube temperatures below 250°F (121°C).

UltraShift™ ASW Models



Caution: Do not introduce additives and friction modifiers.



Caution: Never mix engine oils and synthetic transmission oils in the same transmission. When switching between types of lubricants, all areas of each affected component must be thoroughly drained.



Caution: Do not mix lubricants of different grades.

Note: For a list of Eaton-approved synthetic lubricants, see TCMT0021 or call 1-800-826-HELP (4357).

Note: The use of lubricants not meeting these requirements will affect warranty coverage.

Note: For lubrication change and inspection intervals, see TCMT0021.

Buy From a Reputable Dealer

For a complete list of approved and reputable dealers, write to: Eaton Corporation, Worldwide Marketing Services, P.O. Box 4013, Kalamazoo, MI 49003

Synthetic Dextron III ATF

Synthetic Dextron III ATF must be used in the wet clutch portion of the transmission.

CD-50

CD-50 must be used in the gearbox portion of the transmission.

Maintenance and Lubricant Change Intervals

Transmission inspections and lubricant changes are outlined below.

For a list of Eaton Roadranger-approved lubricants, order publication TCMT0020.

Lubricant Inspection and Change Interval (On-highway)

Interval	Description
First 1,000 to 1,500 miles	Inspect oil levels. Check for leaks.
Every 2,500 miles	Inspect lubricant level. Perform Transmission Inspection.
Every 5 years or 500,000 miles, whichever occurs first	Change wet clutch oil and filters.

Checking Wet Clutch Lubricant

The wet clutch portion is checked using a dipstick located in the engine compartment.

Proper Wet Clutch Lubricant Level

Wet clutch lubricant level should be checked when idling in neutral for at least 2 minutes, with the transmission temperature between 60° F and 120° F (15.5° C and 48.8° C). Proper level is obtained when the lubricant is between the cold Add mark and the cold Full marks on the dipstick. Due to thermal expansion of the lubricant, it is not recommended to check the level when the transmission is above 120° F (48.8° C).



Checking Gearbox Lubricant

The gearbox portion is checked at the lubricant fill plug located on the right side of the gear case.

Cooler

A Transmission Clutch Cooler must be used with the Eaton UltraShift AW3 transmission. The cooler sizing must meet the requirements specified in TRIG0930.

Proper Gearbox Lubricant Level

The gearbox lubricant is at the proper level when it is even with bottom of the fill hole. When you remove the plug to check the lubricant level, lubricant should seep out. Do not use your finger to feel for the lubricant. Even if you can touch the lubricant, it may not be at the proper level. In a transmission, 1 inch of lubricant level equals about 1 gallon of lubricant.

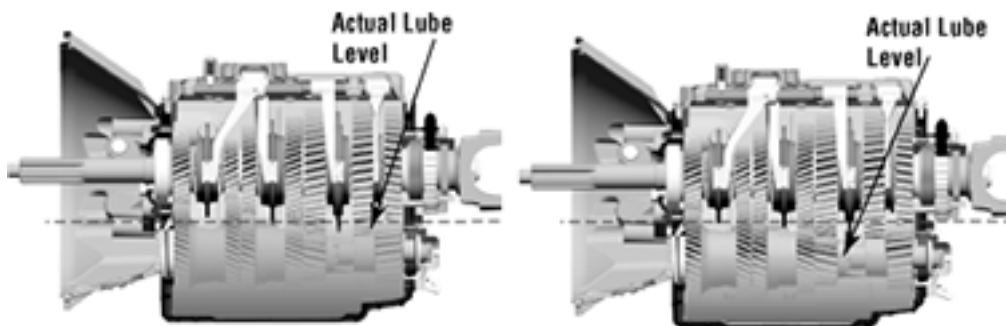

Drain the Transmission Gearbox and Wet Clutch Housing

1. Locate drain plugs at the bottom of the transmission gear case and clutch housing oil pan.
2. Place a drain pan under each drain plug.
3. Remove both drain plugs. Allow the lubricants to drain completely.
4. Disconnect both cooler lines at the wet clutch housing.
5. Pressurize one line with 20 PSI until all lubricant is forced out of the cooler.
6. Reconnect both cooler lines.

Change Wet Clutch Filters

Change the lubricant filters when the transmission lubricant is changed. Detailed information can be found on removal and replacement of the oil filters in this service manual.

Transmission filters should be changed during regular lubrication intervals. Inspection of the transmission filter should be conducted during preventative maintenance checks for damage or corrosion. Replace as necessary.

Fill the Transmission

1. Install the Transmission Gearbox Drain Plug and tighten to 45-55 lb-ft. (60-73 Nm). Sealant is not required on the drain plug threads.
2. Install the Clutch Housing Oil Pan Drain Plug and torque to 34-48 lb-ft. (45-64 Nm). Sealant is not required on the drain plug thread.
3. Fill the Transmission Gearbox with the recommended lubricant until it seeps out of the fill hole.
4. Install the fill plug and torque to 25-35 lb-ft. (33-47 N•m).
5. Slowly fill the clutch through the dipstick tube with an initial fill of 18 pints (8.5 liters) of the recommended lubricant.
6. Place the transmission in neutral position apply the parking brakes. Start the engine and let idle for 5 minutes. This allows oil to fill the wet clutch system and cooling system. Add oil as needed to obtain a level at the proper temperature range. Total oil quantity at this time varies depending on the cooling system capacity.

7. Increase the engine idle slowly to 1500 RPM for 2 minutes. Now, recheck the oil level at normal idle speed in neutral, again adding oil to obtain a level at the proper temperature range.
8. Install the dipstick and tighten securely.

Clutch Calibration

The ASW system automatically provides for clutch wear. The system will initiate a clutch calibration once per vehicle power up, when certain vehicle conditions are right. Of these conditions, the most important ones include:

- When the engine is running at idle speed.
- During normal operating temperature.
- When the vehicle is stopped.
- When neutral is selected on the Shift Control.

During calibration, the clutch is partially engaged until the engine begins to slightly lug down. It will then disengage the clutch and repeat this process several times. The calibration process usually takes as little as 30 seconds, but can take as long as 2 minutes. The calibration will be aborted when any position other than neutral is selected on the Shift Control.

If the vehicle is not engaging smoothly from a stop, it is possible the clutch needs to be re-calibrated. If it was not calibrated during the current power up, stop the vehicle with the engine idling at normal operating temperature and place the Shift Control in neutral. Wait 2 minutes. If the calibration is being performed, you should hear the engine slightly lug down and then return to its no-load condition several times.

If calibration does not occur, a power down or power up will initiate a calibration.

Maintenance and Lubricant Change Intervals

Transmission inspections and lubricant changes are outlined below.

For a list of Eaton Roadranger-approved lubricants, order publication TCMT-0020.

Lubricant Inspection and Change Interval (On-highway)

Interval	Description
First 1,000 to 1,500 miles	Inspect oil levels. Check for leaks.
Every 2,500 miles	Inspect lubricant level. Perform Transmission Inspection.
Every 5 years or 500,000 miles, whichever occurs first	Change wet clutch oil and filters.

Checking Wet Clutch Lubricant

The wet clutch portion is checked using a dipstick located in the engine compartment.

Proper Wet Clutch Lubricant Level

Wet clutch lubricant level should be checked when idling in neutral, with the transmission temperature between 60° F and 120° F (15.5° C and 48.8° C) and when the vehicle has been idling in neutral for at least 2 minutes. Proper lubricant level is obtained when the lubricant is between the cold Add mark and the cold Full marks on the dipstick. Due to thermal expansion of the lubricant, it is not recommended to check the level when the transmission is above 120° F (48.8° C).

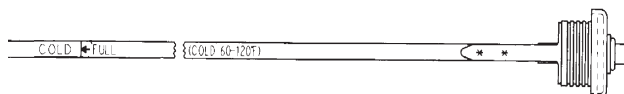

Checking Gearbox Lubricant

The gearbox portion is checked at the lubricant fill plug located on the right side of the gear case.

Cooler

A Transmission Clutch Cooler must be used with the Eaton UltraShift AW3 transmission. The cooler sizing must meet the requirements specified in this TRIG0930

Proper Gearbox Lubricant Level

The gearbox lubricant is at the proper level when it is even with bottom of the fill hole. When you remove the plug to check lubricant level, lubricant should seep out. Do not use your finger to feel for the lubricant. Even if you can touch the lubricant, it may not be at the proper level. In a transmission, 1 inch of lubricant level equals about 1 gallon of lubricant.

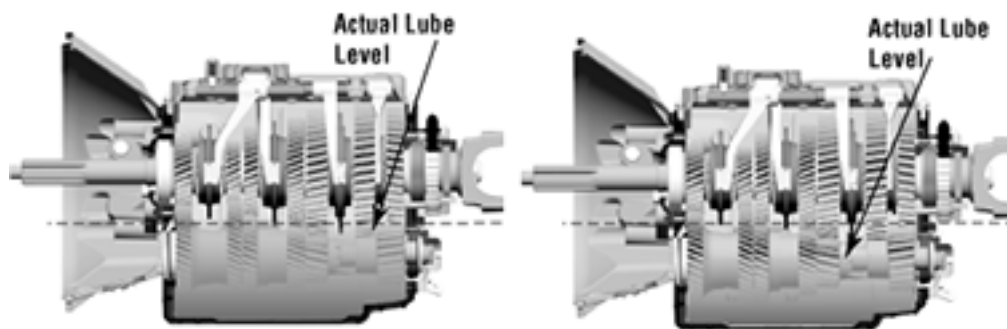

Drain the Transmission Gearbox and Wet Clutch Housing

1. Locate drain plugs at the bottom of the transmission gear case and the clutch housing oil pan.
2. Place a drain pan under each drain plug.
3. Remove both drain plugs and allow the lubricants to drain completely.
4. Disconnect both cooler lines at the wet clutch housing.
5. Pressurize 1 line with 20 PSI until all lubricant is forced out of the cooler.
6. Reconnect both cooler lines.

Change Wet Clutch Filters

Change the lubricant filters when the transmission lubricant is changed. Detailed information can be found on removal and replacement of the oil filters in this service manual.

Transmission filters should be changed during regular lube intervals. Inspection of the transmission filter should be conducted during preventative maintenance checks for damage or corrosion. Replace as necessary.

Fill the Transmission

1. Install the transmission gearbox drain plug and tighten to 45-55 lb-ft. (60-73 Nm). Sealant is not required on the drain plug threads.
2. Install the Clutch Housing Oil Pan Drain Plug and torque to 34-48 lb-ft. (45-64 Nm). Sealant is not required on the drain plug thread.
3. Fill the transmission gearbox with the recommended lubricant until the lubricant seeps out of the fill hole.
4. Install the fill plug and torque to 25-35 lb-ft. (33-47 Nm).
5. Slowly fill the clutch through the dipstick tube with an initial fill of 18 pints (8.5 liters) of the recommended lubricant.
6. Place the transmission in neutral position apply the parking brakes. Start the engine and let idle for 5 minutes. This allows oil to fill the wet clutch system and cooling system. Add oil as needed to obtain a level at the proper temperature range. Total oil quantity at this time varies depending on the cooling system capacity.

7. Increase the engine idle slowly to 1500 RPM for 2 minutes. Now, recheck the oil level at normal idle speed in neutral, again adding oil to obtain a level at the proper temperature range.
8. Install the dipstick and tighten securely.

Clutch Calibration

The ASW system automatically provides for clutch wear. The system will initiate a clutch calibration once per vehicle power up, when certain vehicle conditions are right. Of these conditions, the most important ones include:

- When the engine is running at idle speed.
- During normal operating temperature.
- When the vehicle is stopped.
- When neutral is selected on the Shift Control.

During calibration, the clutch is partially engaged until the engine begins to slightly lug down. It will then disengage the clutch and repeat this process several times. The calibration process usually takes as little as 30 seconds, but can take as long as 2 minutes. Calibration will be aborted when any position other than neutral is selected on the Shift Control.

If the vehicle is not engaging smoothly from a stop, it is possible that the clutch needs to be recalibrated. If it was not calibrated during the current power up, stop the vehicle with the engine idling at its normal operating temperature and place the Shift Control in neutral. Wait 2 minutes. If calibration is being performed, you should hear the engine slightly lug down and then return to its no-load condition several times.

If calibration does not occur a power down and power up will initiate a calibration.

Tool Specifications

General Tools

The following general tools are available from several tool manufacturers such as Snap-On, OTC and many others.

TOOL	PURPOSE
0-100 lb-ft. (0-135 Nm) 1/2" (12.7 mm) drive Torque Wrench	General torquing of fasteners (Typically 15-80 lb-ft. (20-108 Nm))
0-600 lb-ft. (0-810 Nm) 3/4" or 1" (19 mm or 25.4 mm) drive Torque Wrench	Torquing of Output Nut
0-50 lb. in. (0-5.62 Nm) 3/8" (9.52 mm) drive Torque Wrench	General torquing of fasteners
2 3/4" (70 mm) or Socket - Standard Depth	To remove the Output Yoke/Flange Nut
Large Brass Drift 3/4" x 12" (19 mm x 304.8 mm)	Used to protect shafts and bearings during removal
Large Dead Blow Hammer or Maul 32 ounces	To provide force for shaft and bearing removal
2 Air Pressure Gauges 0-150 PSI (0-10.34 BAR)	To troubleshoot and verify correct operation of air system
3/8" Drive Deepwell socket set 3/8" - 1" (9.5 mm - 25.4 mm)	To remove/install cap screws and nuts
3/8" Drive Shallow socket set 3/8" - 1" (9.5 mm - 25.4 mm)	To remove/install cap screws and nuts
Snap Ring Pliers - Large Standard External	To remove the snap rings at the auxiliary drive gear, input shaft bearing and countershaft bearings
Feeler Gauges	To set mainshaft washer endplay and auxiliary tapered bearing endplay
Open-end wrench set 3/8" - 1" (9.52 mm -25.4 mm)	To remove certain airline connections

Torque Specifications

Correct torque application is extremely important to ensure long transmission life and dependable performance.

Over-tightening or under-tightening can result in a loose installation and, in many instances, eventually cause damage to transmission gears, shafts or bearings. Use of a thread sealer and locking compound is recommended for all cap screws. Do not torque cap screws dry.

Description	Torque Value lb-ft. [N•m]	Thread size	Additional Comments
Transmission-to-Engine Cap Screws	Refer to OEM for specification		
Clutch-to-Flywheel Cap Screws			
7/16 x 2.25 x 14	40 - 50 lb-ft. [54 - 68 Nm]	7/16 x 2.25 x 14	
3/8 x 2.25 x 16	30 - 35 lb-ft. [41 - 47 N•m]	3/8 x 2.25 x 16	
M10 x 1-3/8	26 - 35 lb-ft. [35 - 47 N•m]	M10 x 1-3/8	
M10 x 1-3/4	26 - 35 lb-ft. [35 - 47 N•m]	M10 x 1-3/4	
6 (Small PTO Cover Cap Screws)	20 - 25 lb-ft. [27 - 34 N•m]	3/8"-16	Apply Loctite 242 to threads.
8 (Large PTO Cover Cap Screws)	50 - 65 lb-ft. [68 - 88 N•m]	7/16"-14	Apply Loctite 242 to threads.
4 Electric Shifter Cap Screws	30 - 45 lb-ft. [48 - 61 N•m] cast and 20 - 25 lb-ft. [27 - 34 N•m] aluminum	3/8" - 16	Apply Loctite 242 to threads.
1 Reverse Switch	20 - 25 lb-ft. [27 - 34 N•m]	9/16"-18	
1 Neutral Switch/Cap	20 - 25 lb-ft. [27 - 34 N•m]	3/4"-16	
3 ECU Cap Screws (Medium-Duty)	7 - 9 lb-ft. (9.5 - 12.2 N•m)	1/4" - 20	Apply Loctite 242 to threads.
3 ECU Nuts (Heavy-Duty)	7 - 9 lb-ft. [9.5 - 12.2 N•m]	.250 - 20 UNC	
2 Transmission ECU 38-Way Connectors Cap Screws	25 +/- 3 lb-in. [2.82 +/- .33 N•m]	M5 x 0.8	

Description	Torque Value lb-ft. [N•m]	Thread size	Additional Comments
3 ECU Bracket Nuts (Heavy-Duty)	20 - 25 lb-ft. [27 - 34 N•m]	.3125 - 18 UNC	
3 ECU Bracket Studs (Heavy-Duty)	35 - 45 lb-ft. [48 - 61 N•m]	.375 - 16 UNC	
2 Harness Bracket Cap Screws	20-25 lb-ft. [27-34 N•m]	.3125 - 18 UNC	
1 Push Button Shift Controller 30-Way Connector Cap Screw	10 +/- 3 lb-in. [1.1 +/- 0.33 N•m]		
2 Push Button Shift Controller Backing Plate Nuts and Lock Washers	14-16 lb-in. [1.6-1.8 N•m]		
6 Inertia Brake Cap Screws	40-45 lb-ft. [54- 61.0 N•m]	3/8"-16	Apply Loctite 242 to threads.
2 LCIB Mounting Studs	60 lb-ft. [81 N•m]	5/8"- 11	
2 LCIB Mounting Nuts	140-150 lb-ft. [190-203 N•m]	5/8"- 18	
4 ECA Cap Screws	35-45 lb-ft. [47-61 N•m]	3/8"-16	Apply Loctite 242 to threads.
3 ECA Support Bracket Cap Screws	35-45 lb-ft. [47-61 N•m]	3/8"-16	Apply Loctite 242 to threads.
1 ECA Engine Speed Sensor Jam Nut	15 lb-ft. [20 N•m]	3/4"	Turn in until touches and then back off 1/2-turn. The jam nut is then torqued down to hold the sensor in place.
2 Inertia Brake Hose Fittings	30-40 lb-ft. [41-54 N•m]	3/4"-16	
4 Splitter Solenoid Cap Screws	21-27 lb-in. [2.4-3.1 N•m]	#10-24	
4 Range Solenoid Cap Screws	21-27 lb-in. [2.4-3.1 N•m]	#10-24	
1 Output Shaft Speed Sensor Cap Screw (MD)	8-10 lb-ft. [10.8-13.6 N•m]	1/4"-20	
1 Main Shaft Speed Sensor Cap Screw	8-10 lb-ft. [10.8-13.6 N•m]	1/4"-20	
1 Input Shaft Speed Sensor Cap Screw	8-10 lb-ft. [10.8-13.6 N•m]	1/4"-20	

Description	Torque Value lb-ft. [N•m]	Thread size	Additional Comments
2 Rail Sensor Cap Screws	21–27 lb-in. [2.4–3.1 N•m]		
2 Gear Sensor Cap Screws	21–27 lb-in. [2.4–3.1 N•m]		
2 Air Filter Regulator Cap Screws	8–12 lb-ft. [10.8–16.02 N•m]	1/4"-20	Apply Loctite 242 to threads.
1 Lubricant fill plug (6-Speed)	45–55 lb-ft. [61–75 N•m]	3/4-14 NPT	
1 Lubricant fill plug (13,10,18-speed)	60–75 lb-ft. [81–102 N•m]	1¼-NPT	
1 Cross-shaft Plug	34–48 lb-ft. [46–65 N•m]	1.3125 - 12	
2 Lifting Bracket Cap Screws	35–45 lb-ft. [47–61 N•m]	3/8"-16	Apply Loctite 242 to threads.
1 Output Yoke Nut (6-Speed)	500 ± 25 lb-ft. [678 ±34 N•m]		
1 Output Yoke Nut (13,10,18-Speed)	450–500 lb-ft. [610–678 N•m]		
2 Output Yoke Cap Screws (ECA)	70–85 lb-ft. [95–115 N•m]	M12 x 1.25	Spirallock Threads™: No thread adhesive necessary.
4 Rear Bearing Cover Cap Screws (6-Speed)	60–70 lb-ft. [81–95 N•m]	1/2-20	Apply Loctite 242 to threads.
Transmission Nodal Mount Cap Screws	Refer to OEM for Specification		Apply Loctite 242 to threads.
4 Rear Bearing Cover Cap Screws (13,10,18-Speed)	35–45 lb-ft. [47–61 N•m]	3/8-16	Apply Loctite 242 to threads.
Transmission Rear Mount Nuts/Cap Screws	Refer to OEM for Specification		
6-Speed AW3 Specific			
Oil cooler line fitting	50–60 lb-ft. [68–81 N•m]		
Oil cooler line nut	50–60 lb-ft. [68–81 N•m]		
2 Dipstick tube fitting	60–70 lb-ft. [81–95 N•m]	1 5/8"-12	
1 Wet clutch drain plug	34–48 lb-ft. [46–65 N•m]		

Description	Torque Value lb-ft. [N•m]	Thread size	Additional Comments
12 Flywheel to Drive Coupler Cap Screws	35–40 lb-ft. [47–55 N•m]	3/8 x 16 x 1-1/4	
High Pressure Oil Filter	25–35 lb-ft. [34–47 N•m]		
Low Pressure Oil Filter			Turn until seal touches, then tighten with a 1/2" drive 3/4 to 1 full turn.

Torque Overview

Heavy-Duty

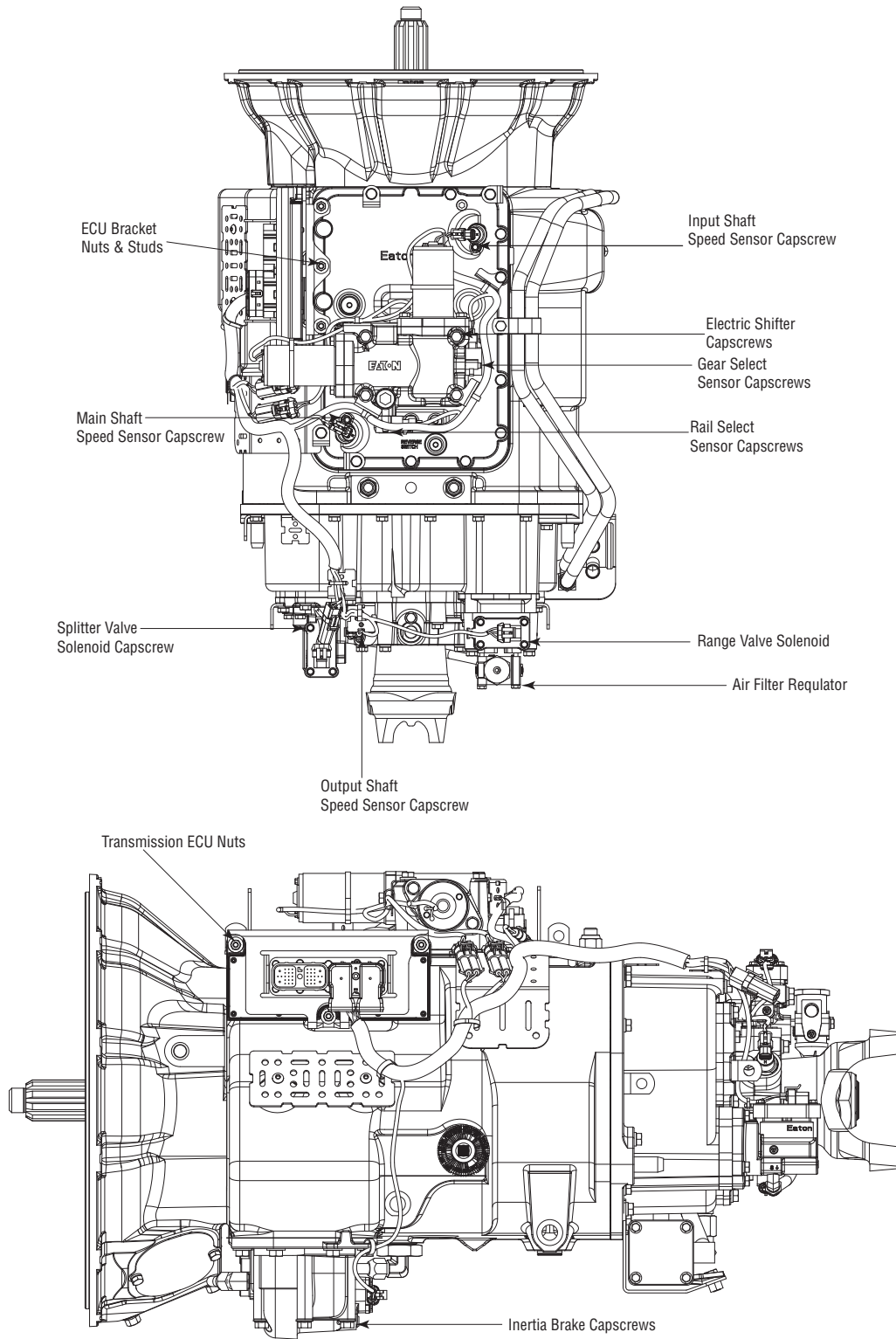

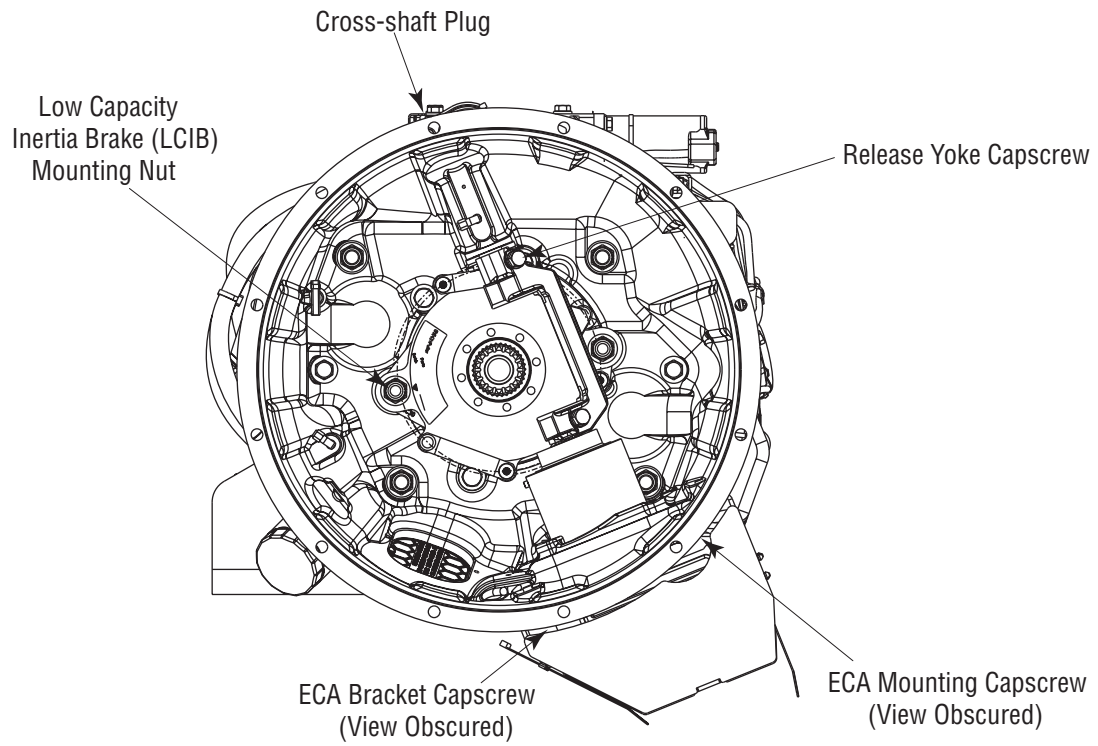

Medium-Duty

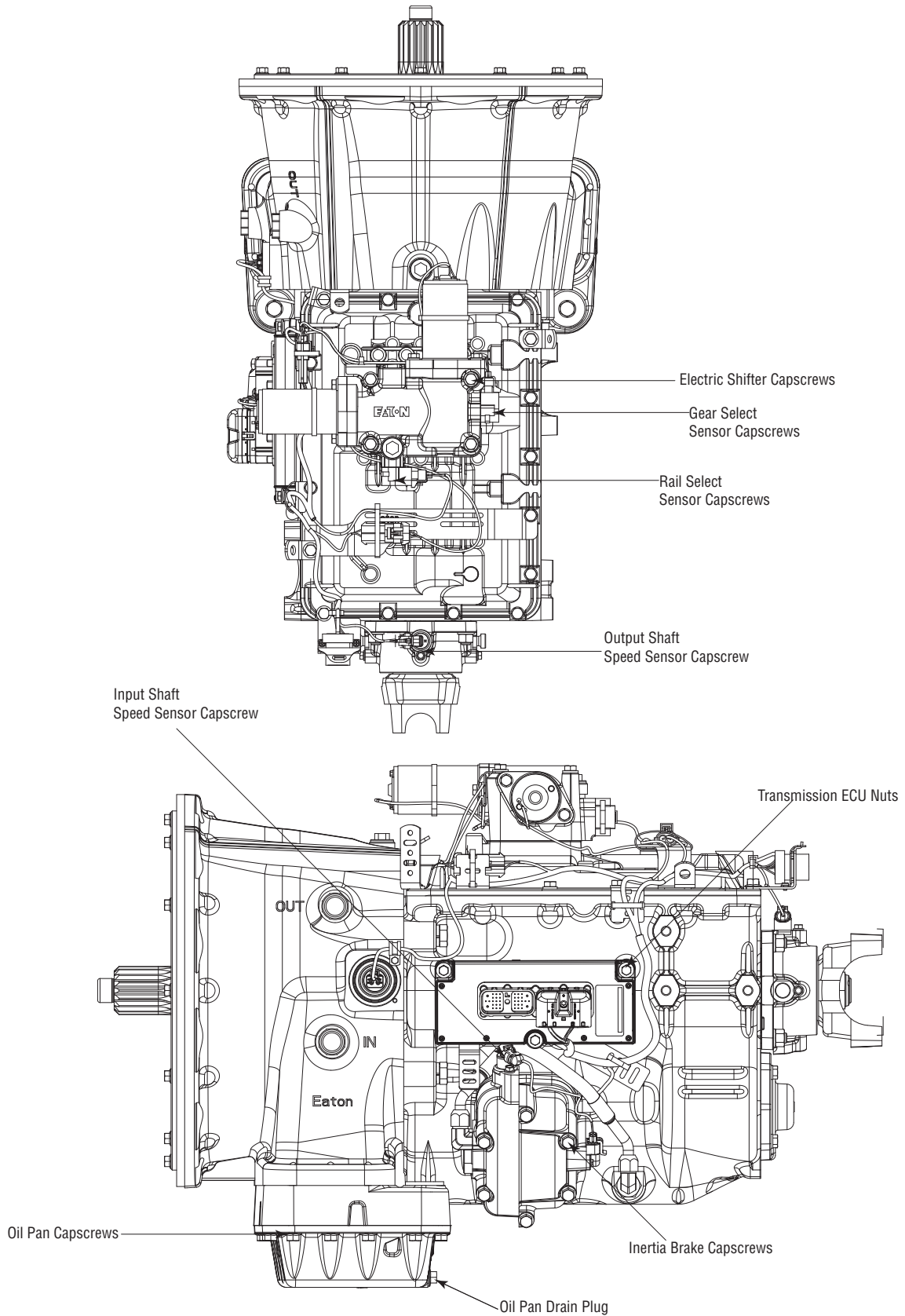

Grade Sensor Calibration

The Grade Sensor is mounted inside the Transmission ECU (TECU) and is essential for Hill Start Aid. It also provides information to the TECU to assist in smooth vehicle launch and shifting. This sensor must be calibrated initially at the OEM factory and anytime the TECU is replaced in the field.

An active FC68 FMI13 indicates a calibration is needed, and it will go inactive upon successful calibration. (See TRTS0930 Troubleshooting Guide for detailed information on FC68)

The Grade Sensor can be calibrated via ServiceRanger or an Operator-Triggered Special Function.

Here are instructions required before performing grade sensor calibration with ServiceRanger or Operator Triggered procedure:

1. Vehicle must be on level ground before initiating the grade sensor calibration.
2. Verify the suspension is fully aired.
3. Verify the suspension is set to proper height.
4. Ground surface must be within +/- 0.5% grade (0.28 degrees) from level.
5. Maximum allowable grade is +/- 0.5 degrees (0.87% grade) from level.

ServiceRanger Procedure

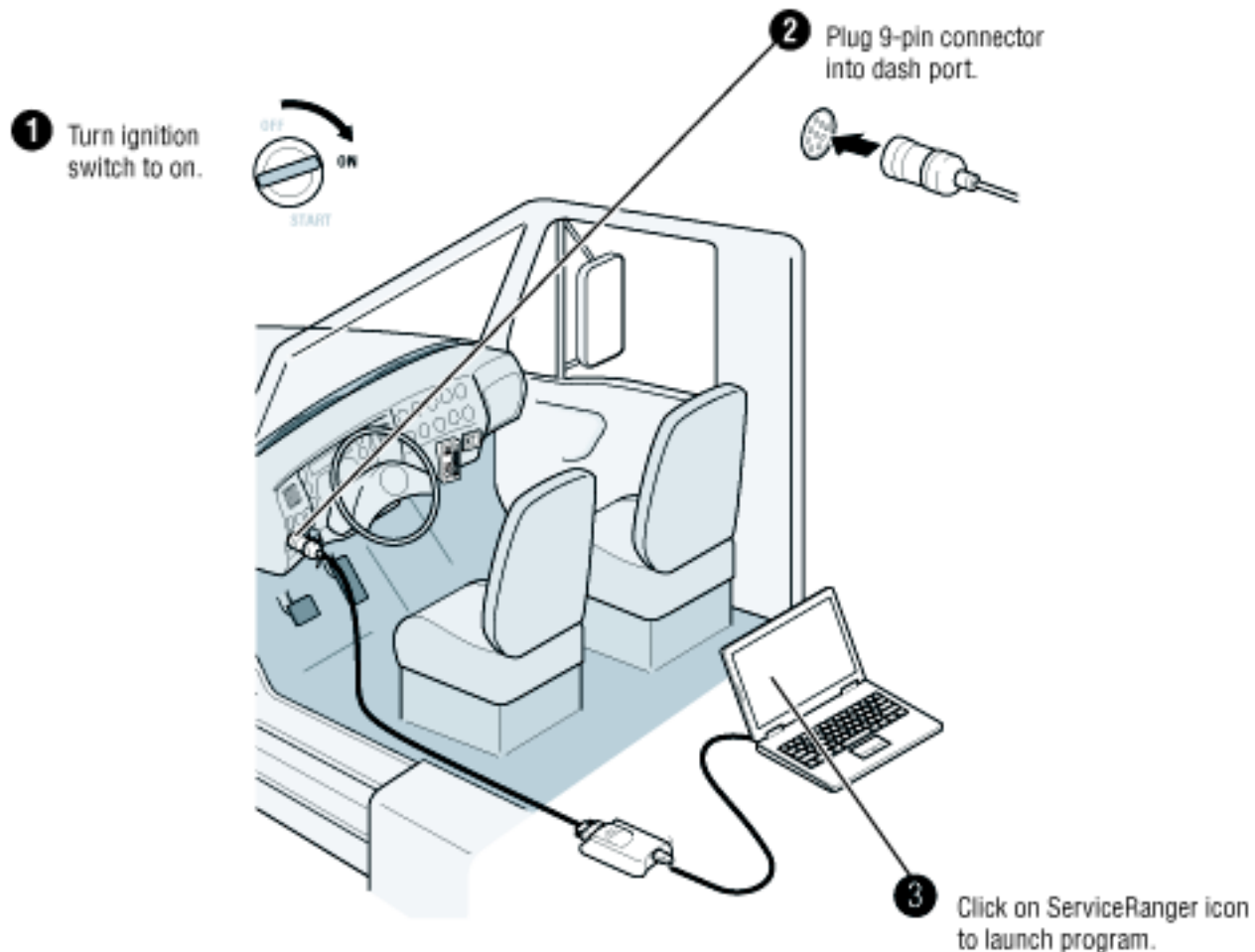

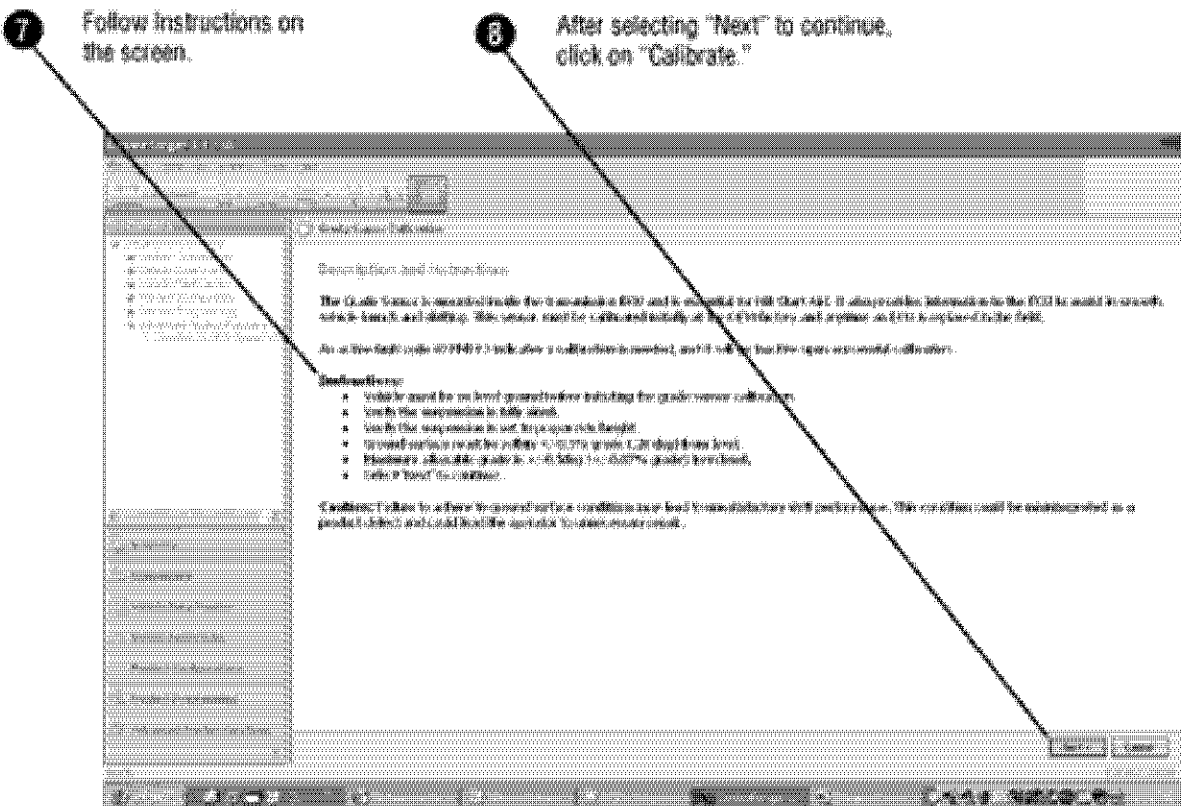
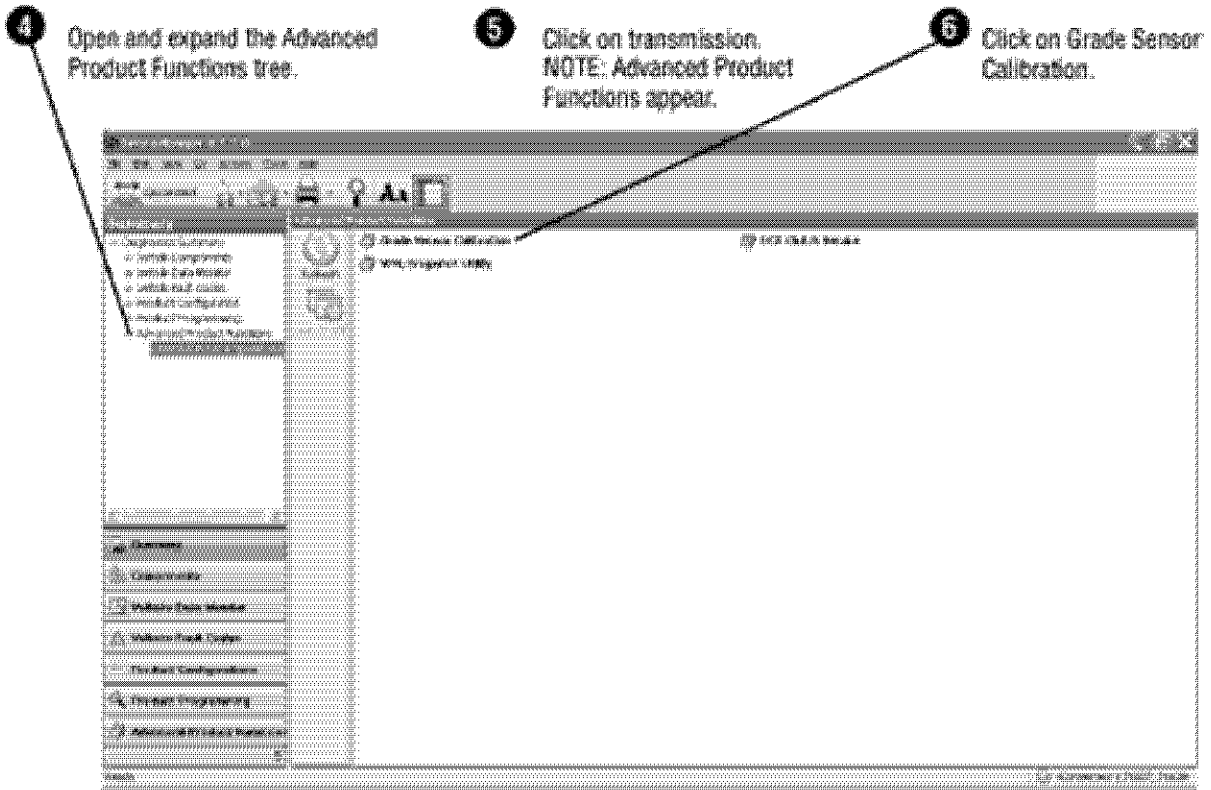

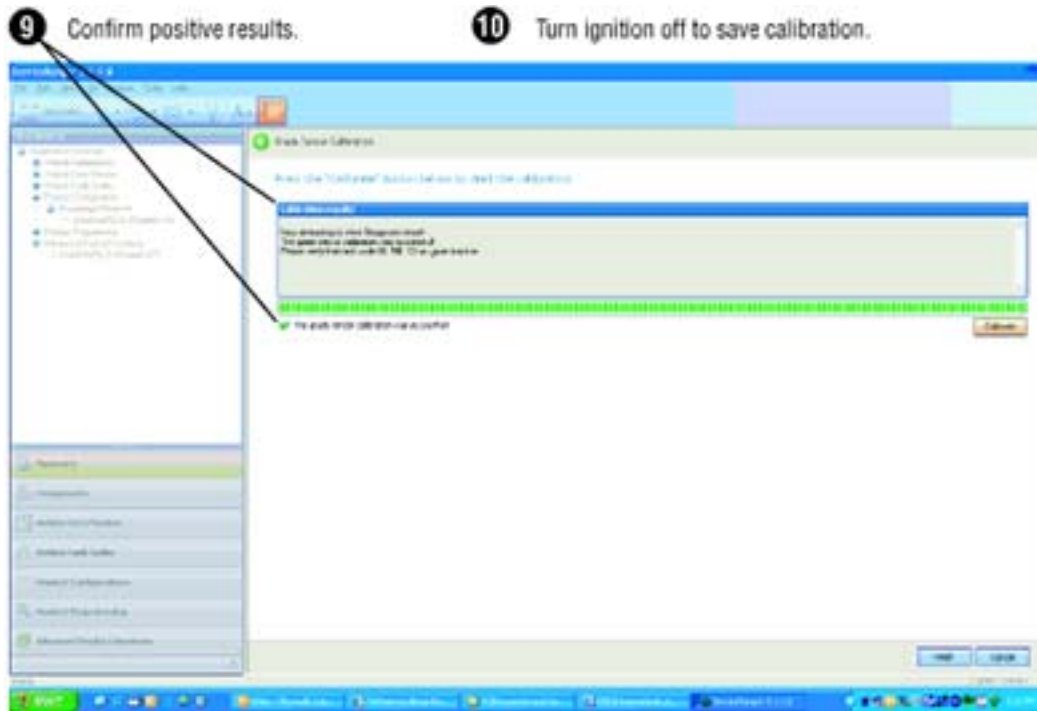

Operator-Triggered Procedure

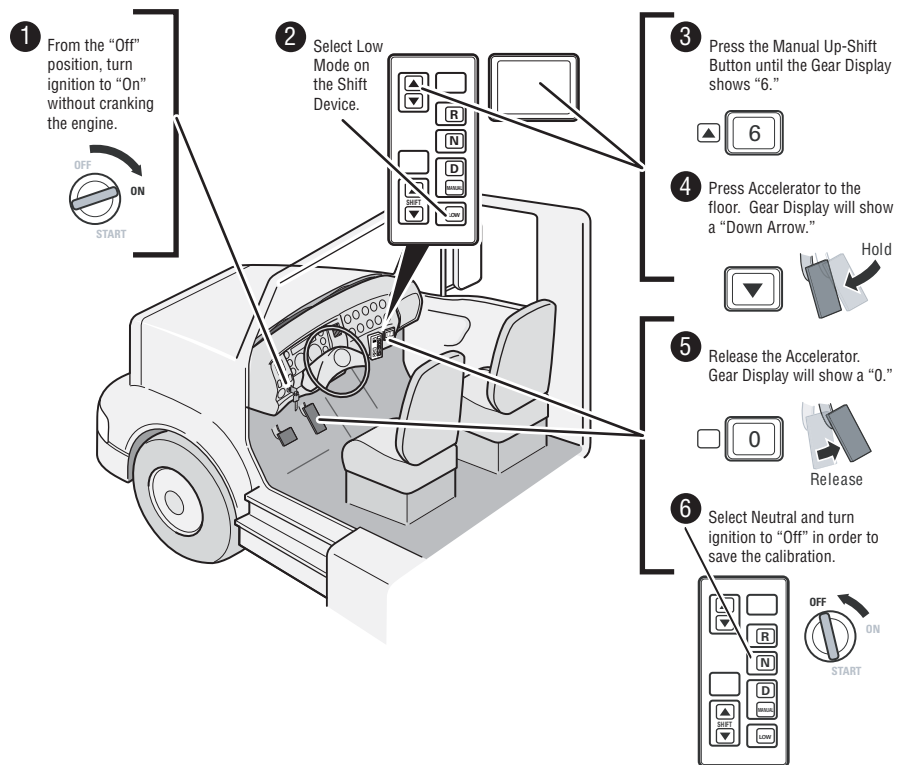

Copyright Eaton, 2013.

Eaton hereby grant their customers, vendors, or distributors permission to freely copy, reproduce and/or distribute this document in printed format. It may be copied only in its entirety without any changes or modifications. THIS INFORMATION IS NOT INTENDED FOR SALE OR RESALE, AND THIS NOTICE MUST REMAIN ON ALL COPIES.

Note: Features and specifications listed in this document are subject to change without notice and represent the maximum capabilities of the software and products with all options installed. Although every attempt has been made to ensure the accuracy of information contained within, Eaton makes no representation about the completeness, correctness or accuracy and assumes no responsibility for any errors or omissions. Features and functionality may vary depending on selected options.

For spec'ing or service assistance, call 1-800-826-HELP (4357) or visit www.eaton.com/roadranger. In Mexico, call 001-800-826-4357.

Roadranger: Eaton and trusted partners providing the best products and services in the industry, ensuring more time on the road.

Eaton
Vehicle Group
P.O. Box 4013
Kalamazoo, MI 49003 USA
800-826-HELP (4357)
www.eaton.com/roadranger

Printed in USA

For parts or service call us
Pro Gear & Transmission, Inc.



1 (877) 776-4600

(407) 872-1901

parts@eprogear.com

906 W. Gore St.

Orlando, FL 32805

