

# Fuller Automated Transmissions TRSM0050

October 2007

RTAO-11710B-AC  
RTAO-11710C-AC  
RTAO-12710B-AC  
RTAO-12710C-AC  
RTAO-13710B-AC  
RTAO-13710C-AC  
RTAO-14710B-AC  
RTAO-14710B-AS  
RTAO-14710C-AC  
RTAO-14710C-AS  
RTAO-15710B-AC  
RTAO-15710C-AC  
RTAO-16710B-AC  
RTAO-16710B-AS  
RTAO-16710C-AC  
RTAO-16710C-AS  
RTLO-14918B-AS  
RTLO-16918B-AS

RTLO-18918B-AS  
RTLO-20918B-AS



*Powering Business Worldwide*

BACKED BY

**Roadranger**

SUPPORT

For parts or service call us  
Pro Gear & Transmission, Inc.



**1 (877) 776-4600**

**(407) 872-1901**

**parts@eprogear.com**

**906 W. Gore St.**

**Orlando, FL 32805**



## Warnings and Cautions



**WARNING:** Follow the specified procedures in the indicated order to avoid personal injury



**CAUTION:** Follow the specified procedures in the indicated order to avoid equipment malfunction or damage.

**Note:** Additional relevant information not covered in the service procedure.



**WARNING:** Before starting a vehicle:

- Sit in the driver's seat
- Place shift lever in neutral
- Set the parking brake



**WARNING:** Before working on a vehicle or leaving the cab with engine running:

- Place shift lever in neutral
- Set the parking brake
- Block the wheels



**WARNING:** When parking the vehicle or leaving the cab:

- Place shift lever in neutral
- Set the parking brake



**CAUTION:** Do not release the parking brake or attempt to select a gear until the air pressure is at the correct level.



**CAUTION:** To avoid damage to the transmission during towing:

- Place shift lever in neutral
- Lift the drive wheels off of the ground or disconnect the driveline



**CAUTION:** Do not operate vehicle if alternator lamp is lit or if gauges indicate low voltage.

Every effort has been made to ensure the accuracy of all information in this manual. However, Eaton Truck Component Operations makes no expressed or implied warranty or representation based on the enclosed information. Any errors or omissions may be reported to Marketing Services, Eaton Truck Component Operations, P.O. Box 4013, Kalamazoo, MI 49003.

Copyright Eaton Corporation, 2001. All rights reserved.

## Introduction

Purpose .....	1
Identification Tag .....	2
Model Designations .....	3
Lubrication Information .....	4
Maintenance/Lubricant Change Intervals .....	5
Preventive Maintenance Overview .....	7
Repair Warnings .....	10

## Service Procedures

Reverse Ball Switch - Overview .....	12
How to Remove the Reverse Ball Switch .....	13
How to Install the Reverse Ball Switch .....	15
Rail Select Sensor - Overview .....	18
How to Remove the Rail Select Sensor .....	19
How to Install the Rail Select Sensor .....	21
Gear Select Sensor - Overview .....	24
How to Remove the Gear Select Sensor .....	25
How to Install the Gear Select Sensor .....	27
Input/Main Shaft Speed Sensors - Overview .....	30
How to Remove the Input/Main Shaft Speed Sensors .....	31
How to Install the Input/Main Shaft Speed Sensor .....	33
Output Shaft Speed Sensor - Overview .....	36
How to Remove the Output Shaft Speed Sensor .....	37
How to Install the Output Shaft Speed Sensor .....	39
Range Valve - Overview .....	42
How to Remove the Range Valve .....	43
How to Install the Range Valve .....	45
Splitter Valve - Overview .....	48
How to Remove the Splitter Valve .....	49
How to Install the Splitter Valve .....	51
Air Filter/Regulator - Overview .....	54
How to Remove the Air Filter/Regulator .....	55
How to Install the Air Filter/Regulator .....	57
Inertia Brake Solenoid - Overview .....	60
How to Remove the Inertia Brake Solenoid .....	61
How to Install the Inertia Brake Solenoid .....	63
Inertia Brake - Overview .....	66
How to Remove the Inertia Brake .....	67
How to Install the Inertia Brake .....	69
Power Module - Overview .....	72
How to Remove the Power Module .....	73
How to Install the Power Module .....	75
Electric Shifter - Overview .....	78
How to Remove the Electric Shifter .....	79
How to Install the Electric Shifter .....	81

Transmission ECU - Overview .....	84
How to Remove the Transmission ECU .....	85
How to Install the Transmission ECU .....	87
Transmission Harness - Overview .....	90
How to Remove the Transmission Harness .....	91
How to Install the Transmission Harness .....	93
Shift Lever - Overview .....	96
How to Remove the Shift Lever .....	97
How to Install the Shift Lever .....	99
Power Relay - Overview .....	102
How to Remove the Power Relay .....	103
How to Install the Power Relay .....	105
System Manager - Overview .....	108
How to Remove the System Manager .....	109
How to Install the System Manager .....	111
Tower Harness - Overview .....	114
How to Remove the Tower Harness .....	115
How to Install the Tower Harness .....	117
Gear Display - Overview .....	120
How to Remove the Gear Display .....	121
How to Install the Gear Display .....	123

---

## **Purpose**

This manual is designed to provide detailed information necessary to service and repair the Automation of Eaton® Fuller® transmissions listed on the front.

## **How to Use This Manual**

The service procedures in this manual are for transmission automation components only. To locate the information you need, simply locate the procedure in the table of contents, turn to the page specified, and follow the procedure.

To service the mechanical portion of the transmission system, refer to the model specific transmission service manual.

## Identification Tag

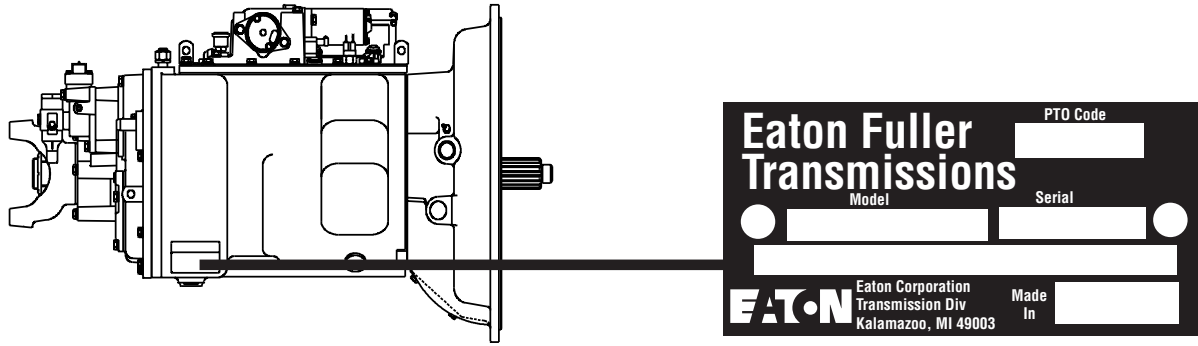

All Eaton® Fuller® Transmissions are identified by the model and serial number. This information is stamped on the transmission identification tag and affixed to the case.

**DO NOT REMOVE OR DESTROY THE TRANSMISSION IDENTIFICATION TAG.**

Have reference numbers handy when ordering replacement parts or requesting service repairs.

## Model Designations

### AutoSelect Nomenclature

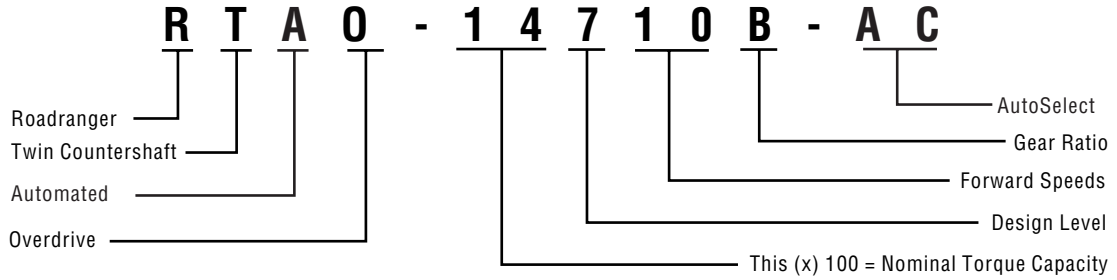

### AutoShift Nomenclature

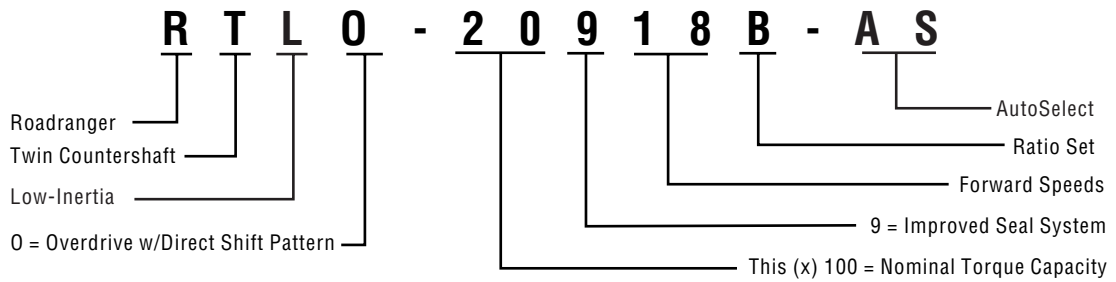
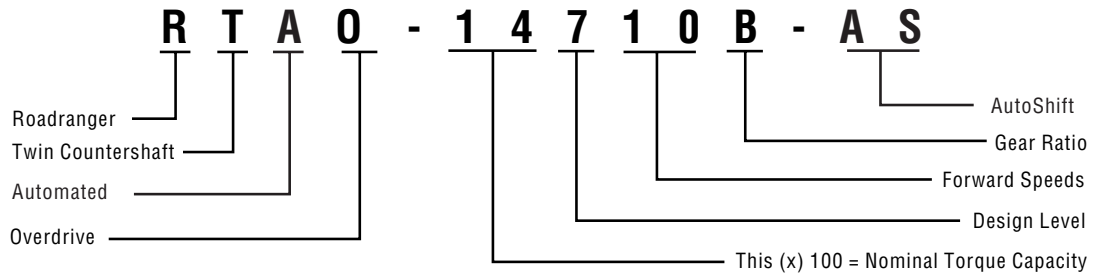

## Lubrication Information

### Recommended Lubricants

Where transmissions are concerned, lubrication is possibly the most important part of keeping a vehicle operating.

Lubricants which meet the Eaton (PS-164) specification are required in AutoSelect/AutoShift transmissions. Lubricants must be approved by Eaton Corporation to qualify for the 5/750,000 warranty. For a list of Eaton® Roadranger® approved lubricants, order item number TCMT-0021.

Type	Grade (SAE)	Ambient Temperature	Drain Interval	Note
Eaton® Roadranger® CD-50 E500 (PS-164)	50	All	250,000* (400,000)/1000 Hrs	Approved for Oil Coolers

\*The first lube change may be extended to 500,000 miles (800,000 km) when a new transmission has been factory filled with a lube that is Eaton approved for 500,000 miles (800,000 km) (E-500, PS-164).



## Maintenance/Lubricant Change Intervals

Transmission inspections and lubricant changes depend on the type of lubricant used and whether the vehicle is used On- or Off-Highway.

**On-Highway Lubricant** - Vehicles operated on paved roads, interstate highways, and turnpikes are designated as on-highway vehicles. Lubricant change and inspection intervals are the most generous for on-highway vehicles using synthetic lubricants.

**Off-Highway Lubricant** - When operating vehicles with AutoSelect/AutoShift transmissions in off-highway applications such as coal trucks or mining vehicles, it is more important to use time rather than mileage to keep the transmission within its proper preventive maintenance schedule. Off-highway applications are divided into two categories, severe and normal. 'Severe off-highway' is the designation used when there is excessive dust and dirt. 'Normal off-highway' is for applications where dust and dirt are minimal.

**PM Interval** - The PM interval in off-highway vehicles with AutoSelect or AutoShift transmissions is every 40 hours.

**Lubricant Change Interval** - The lubricant must be changed in AutoSelect/AutoShift transmissions in off-highway vehicles every 500 hours in severe applications, and every 1000 hours for vehicles in normal applications.

Type	Grade (SAE)	Ambient Temperature	Drain Interval	Note
Eaton® Roadranger® CD-50 E500 cm (PS-164)	50	All	250,000* (400,000)/1000 Hrs	Approved for Oil Coolers
*The first lube change may be extended to 500,000 miles (800,000 km) when a new transmission has been factory filled with a lube that is Eaton approved for 500,000 miles (800,000 km) (E-500, PS-164).				

## Oil Level

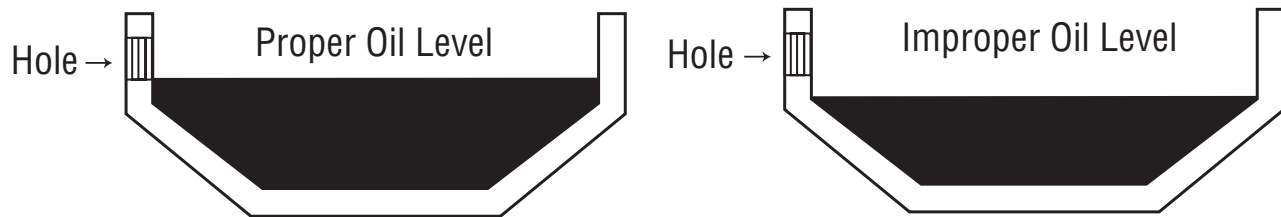

When checking the transmission lubricant there are two important points to know: where to check the lubricant and what the proper lubricant level is. Always be cautious when checking the transmission lubricant as it may be hot.

- **Checking Location** - Check the lubricant at the lubricant fill plug located on the left side of the main transmission case.
- **Proper Lubricant Level** - The lubricant is at the proper level when it is even with the bottom of the fill hole. When you remove the plug to check the lubricant level, lubricant should actually seep out. Do not use your finger to feel for the lubricant. Even if you can touch the lubricant, it may not be at the proper level. In a transmission one inch of lubricant level equals about one gallon of lubricant.

## Recommended Lubricant

Eaton requires the use of Eaton approved lubes meeting the E-500 performance requirements (PS-164) for these transmissions. A current list of approved lubes is available from Eaton Roadranger Field Marketing, call 1-800-826-4357. Failure to use a required lube may affect AutoSelect/AutoShift performance and warranty coverage.

### Buy from a reputable dealer

For a complete list of approved and reputable dealers, write to:

Eaton Corporation  
**Truck Components Operations**  
Global Marketing Services  
P.O. Box 4013  
Kalamazoo, MI 49003  
[http://truck.eaton.com/na/service\\_products/lubricant\\_requirements/](http://truck.eaton.com/na/service_products/lubricant_requirements/)

---

## Preventive Maintenance Overview

To keep a vehicle running properly, it is important to perform preventive maintenance on the vehicle components. This insures the vehicle and its subassemblies will operate properly throughout their useful life. To cover preventive maintenance completely, you must review the following subjects in detail.

- Inspecting the Transmission
- Changing the Fluid
- Vehicle System Effects

## Transmission Inspections

When performing preventive maintenance (PM) inspections, several items must be checked. It is important to perform every step to ensure the transmission meets its life expectancy. Proper PM consists of the following steps:

- Check the transmission oil level
- Inspect under the vehicle for loose/missing bolts
- Check the transmission for air leaks
- Check the transmission for lubricant leaks

## Loose or Missing Bolts

While you are under the vehicle checking the lubricant, make a quick check for loose or missing bolts. Check all bolts on the back box, PTO covers, shift bar housing, clutch housing and transmission controller. Replace any missing or broken bolt with the proper bolt as called out in the illustrated parts listing. Follow the procedure defined in the manual transmission service manual when tightening any bolts.

## Air Leaks

While you are under the vehicle, check for air leaks as well. The two steps when checking for an air leak are inspection and repair.

- **Audible Inspection for Leaks** - To find air leaks, make sure the vehicle air system has at least 90 PSI air pressure. Then, listen for leaks, making sure a vehicle leak is not mistaken for a transmission air leak.
- **Refer to Troubleshooting Procedures for Repair** - Once you find an air leak, use the troubleshooting guide to isolate the air leak to the faulty component.

## Lubricant Leaks

Oil leak repair is very important. An lubricant leak could cause a catastrophic transmission failure. Check for leaks first at the gasket surfaces, the rear seal, and the transmission cooler.

## Visual Check for Leaks at Gaskets

A visual check at each gasket to ensure that no leak is present. Typically a moist spot is acceptable; however drips or larger wet areas are not. Check for leaks at the rear housing, PTO, shift bar housing, shift tower, and clutch housing gasket surfaces. It is also important to ensure that the leak is indeed coming from the transmission. Make sure the lubricant is not being blown back from the engine or another vehicle component.

## Check for Leaks Around the Input Shaft

Check for leaks around the input shaft. Leaks in this area could be caused by a faulty gasket, the input shaft, or pressurization of the main transmission case by the air system. If you find a leak at the input shaft, make sure the air system is not leaking into the case before looking for leaking gaskets.

## Rear Seal

The rear seal is very important in maintaining lubricant in the transmission. If the seal is improperly installed or has failed, the transmission may experience a catastrophic failure. Check the rear seal by performing the following steps:

- **Visual Check For Leak** - Visually inspect the rear seal for a leak. If a rear seal leak is suspected, proper isolation is necessary.
- **Verify the Leak Path** - Other leaks may give the impression the rear seal is leaking. One possible cause is the vehicle speed sensor. Any lubricant leak above and in front of the rear seal could cause lubricant to collect around the seal. Wipe the seal with a clean rag, operate the vehicle, and recheck to verify the leak path. More information can be found in the rear seal maintenance guide (TRSM-0912).

## Transmission Cooler Leaks

If the vehicle is equipped with a transmission lubricant cooler, make sure there are no leaks at the lubricant cooler, hoses, and fitting of the cooler circuit. Repair any cooler leaks as necessary.

## Transmission Fluid Change

When it is time to change the transmission lubricant, there are only a few steps to follow: draining and filling the transmission, draining and filling the cooler (if equipped), and changing the oil filter (if equipped). Remember to be careful when changing the transmission lubricant, as it may be hot.

- **Transmission Drain** - Draining the transmission consists of removing the drain plug located on the bottom of the transmission case. Put a drain pan in place under the drain plug before removing it. Once the oil has finished draining, install the drain plug and torque to 45-55 Lb f ·ft. No sealant is required on the drain plug.
- **Cooler Drain** - If the vehicle is equipped with a transmission cooler, you must drain the cooler as well. To drain the cooler, remove both cooler lines at the transmission and pressurize one line with 30 PSI of air pressure. This will force the oil out of the cooler. Once the cooler has drained, reconnect the coolant lines to the transmission, making sure the lines are not crossed.
- **Transmission Fill** - Remove the transmission fill plug and fill the transmission with the desired approved oil. The transmission is full once oil starts flowing out of the fill hole. Replace the fill plug and torque to 60-70 Lb f ·ft.
- **Cooler Fill** - If the transmission is equipped with a cooler, the best way to fill the cooler is to place the transmission in neutral, start the vehicle, then release the clutch pedal so the input shaft of the transmission can rotate. This allows the pump to fill the cooler. Once the vehicle has run for about one minute, shut it off and recheck the transmission oil level.
- **Filter Change** - If the transmission is equipped with a spin-on oil filter, remove and replace the filter as you would any spin-on filter. It is also necessary to remove the filter when draining the oil from the cooler. As you unscrew the filter, catch the oil that seeps out between the filter opening and the "spin-on" casting.

---

### Vehicle System Effects

Some vehicle systems can affect transmission operation and possibly cause a failure. The major system that can affect AutoSelect or AutoShift is the air system.

#### Air System

If the air system is not given recommended preventive maintenance, it can cause transmission system problems. Although the transmission has an air filter regulator it cannot protect the transmission from contaminants indefinitely. This is why it is important to follow OEM recommendations for air system PM. It is important to regularly drain the air tanks and insure that oil is not being pumped by the air compressor into the vehicle air system. If moisture enters the transmission system, it may cause corrosion. Also, in cold climates it may freeze, preventing the shift mechanisms from operating. If allowed into the system, oil could fill the air system components causing them to lose valuable air volume, slowing or preventing movement.

---

## Repair Warnings

When disassembling various assemblies, lay all parts on a clean bench in the same sequence as removed to simplify assembly and reduce the possibility of losing parts.

Provide a clean work area. Make sure no dirt or foreign material enter the unit during repair and assembly.

Disconnect the vehicle's battery before removing or installing electronic parts.

Since the cost of a new part is generally a small fraction of the total cost of downtime and labor, avoid reusing a questionable part that could lead to additional repairs and expense.

Use of other than recommended tools, parts, and instructions listed in this manual may place the safety of the service technician or vehicle driver in jeopardy.

The location of some components may vary with each O.E.M.

The removal and installation procedure described for each component may vary for your vehicle.

Always use genuine Eaton replacement parts. For a complete list of approved and reputable dealers, write to:

Eaton Corporation

**Truck Components Operations**

Global Marketing Services

P.O. Box 4013

Kalamazoo, MI 49003

[http://truck.eaton.com/na/service\\_products/lubricant\\_requirements/](http://truck.eaton.com/na/service_products/lubricant_requirements/)



## Reverse Ball Switch - Overview

### Special Instructions

None.

### Required Tools

- Torque Wrench with 25 lb.ft. capacity.

### Essential Steps

Install a new fiber washer.

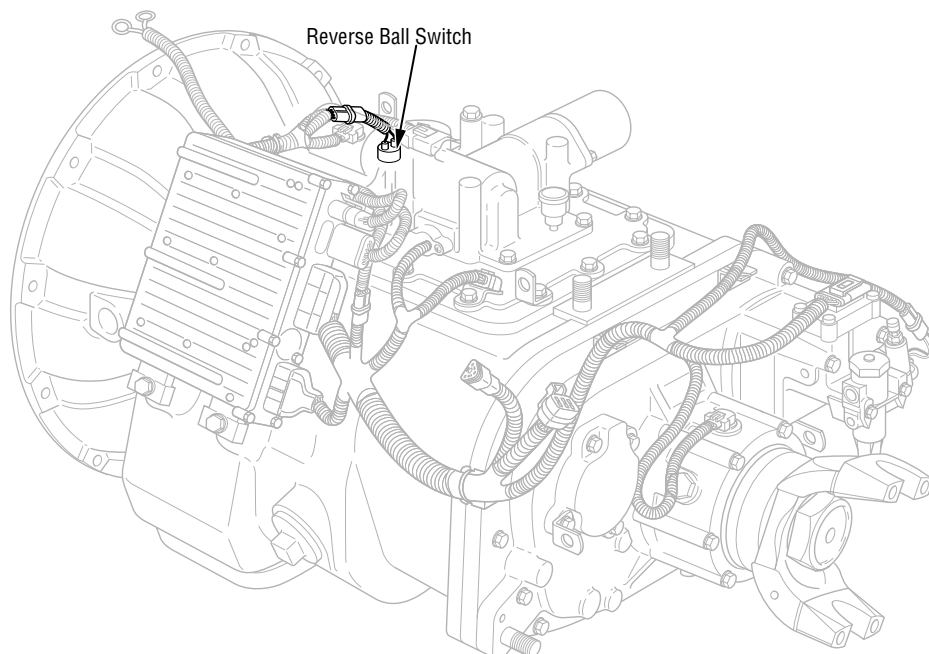



## **How to Remove the Reverse Ball Switch**

### **Procedure-**

1. Disconnect the Transmission Harness from the Reverse Ball Switch.
2. Using a 7/8" wrench, Loosen the Reverse Ball Switch.
3. Remove the Reverse Ball Switch and Fiber Washer from the Shift Bar Housing.

**1**  
Disconnect  
Transmission Harness  
from Reverse Ball Switch

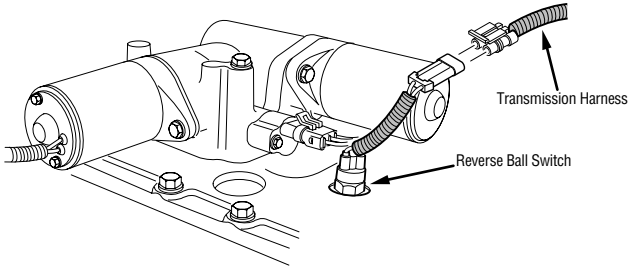

**2**  
Loosen Reverse  
Ball Switch

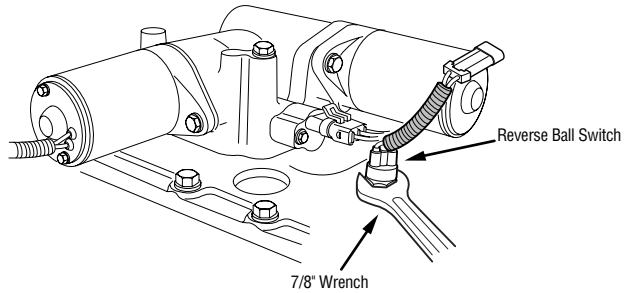

**3**  
Remove Reverse Ball  
Switch and Fiber Washer

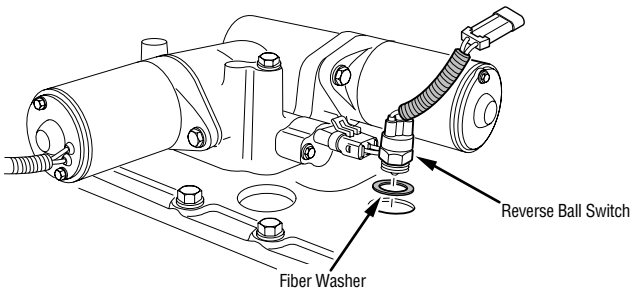

## **How to Install the Reverse Ball Switch**

### **Procedure-**

1. Install a new fiber washer (included in the Reverse Ball Switch service kit) on the Reverse Ball Switch.
2. Using a 7/8" wrench, install and tighten the Reverse Ball Switch to 20-25 lbs. ft. (27.1-33.9 N•m).
3. Connect the Transmission Harness to the Reverse Ball Switch.

### **Final Check**

Verify Harness is locked.

1

Install reverse ball Switch and Fiber Washer

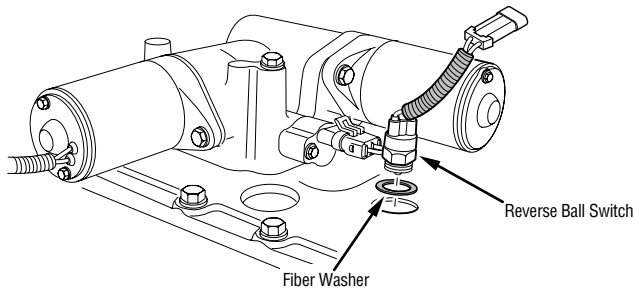

2

Tighten Reverse Ball Switch

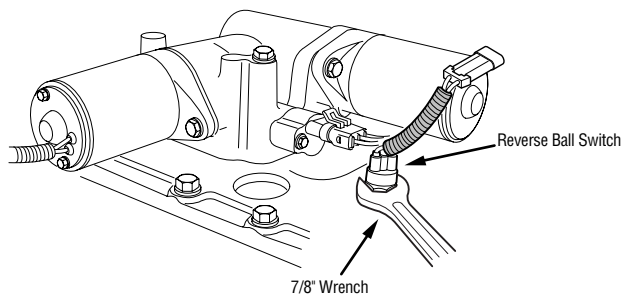

3

Connect Transmission Harness to Reverse Ball Switch

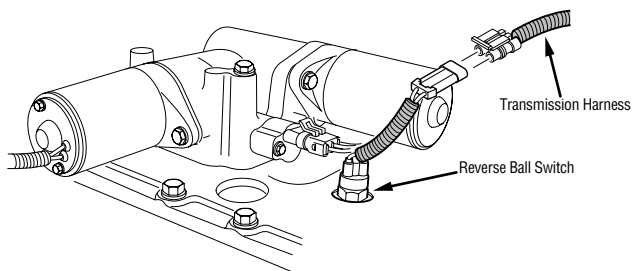

---

**Solo Heavy Duty Clutch - Install, Con't**

## Rail Select Sensor - Overview

### Special Instructions

Install the sensor with the connector on top.

While removing or installing the capscrews, hold the sensor in place. Don't allow it to snap out of position.

### Required Tools

- Basic Hand Tools

### Essential Steps

The shifter module must be calibrated before the vehicle is placed into operation.

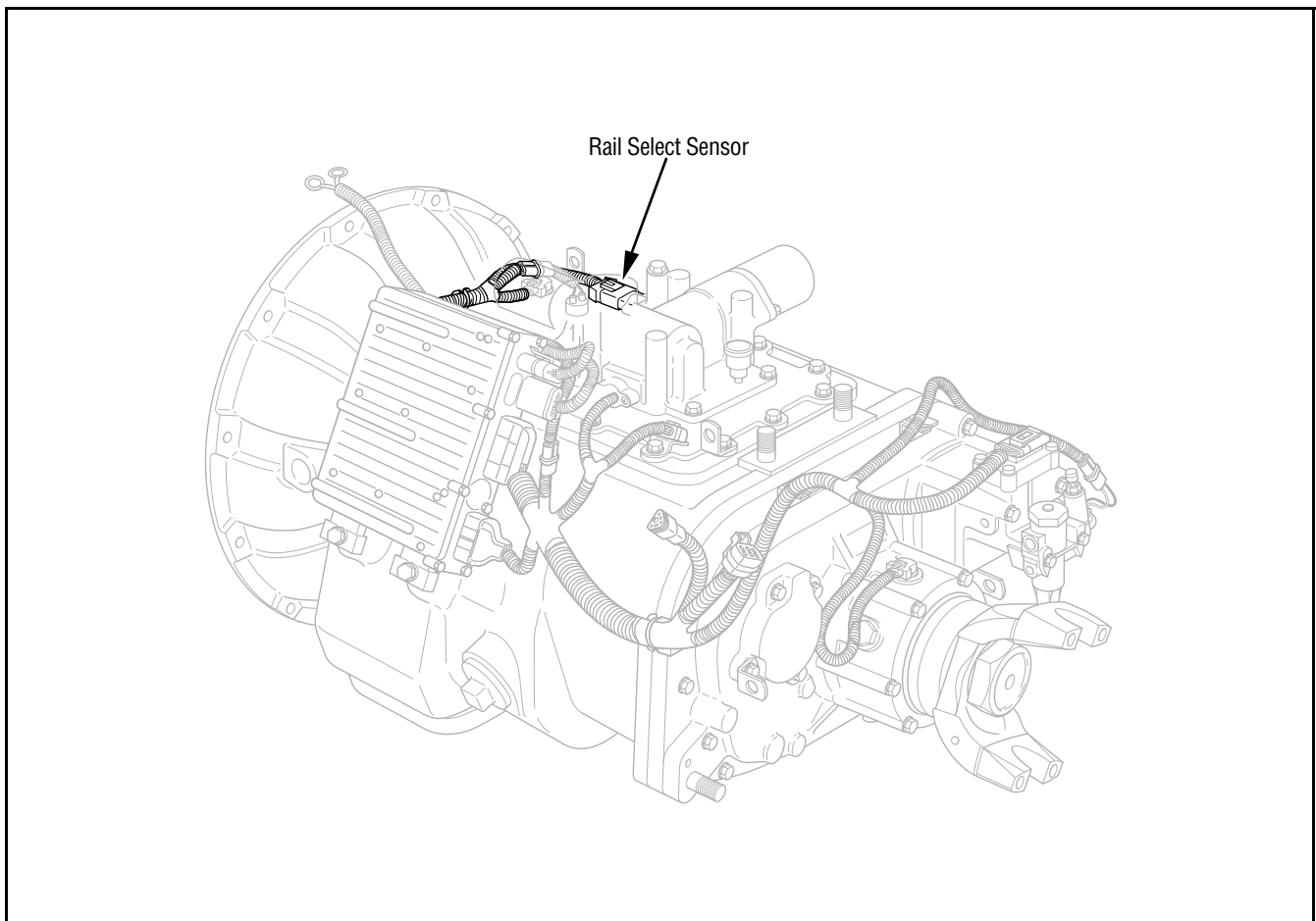

---

## **How to Remove the Rail Select Sensor**

### **Procedure-**

1. Disconnect the Transmission Harness from the Rail Select Sensor.
2. Using a 5/16" wrench, remove the two (2) sensor cap-screws.
3. Carefully allow the sensor to rotate (not snap) to a relaxed position. Then remove the sensor, steel sleeves and O-rings from the housing.
4. Insert your finger into the sensor bore and push the arm slightly.

**1**  
Disconnect  
Transmission Harness  
from Sensor

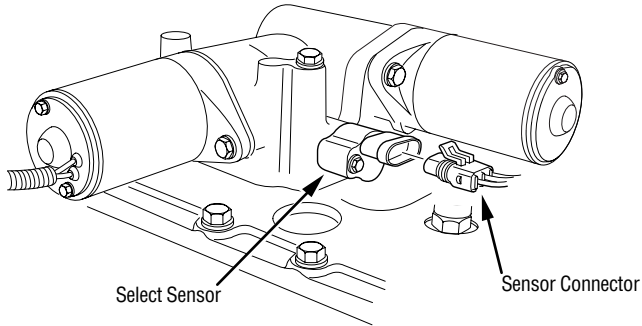

**2**  
Remove Mounting  
Capscrews

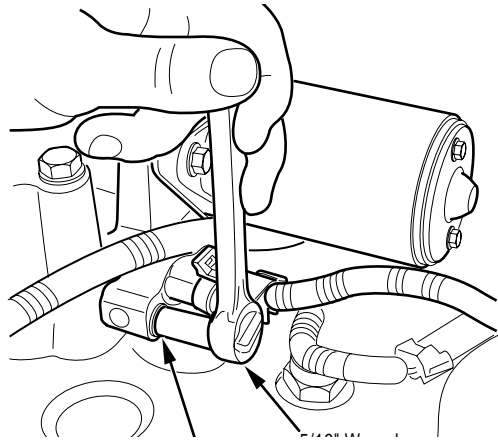

**3**  
Remove Rail  
Select Sensor

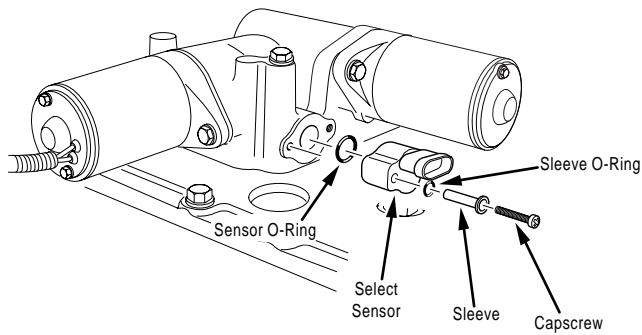



---

## How to Install the Rail Select Sensor

### Procedure-

1. Align the sensor's tab with the slot in the shifter housing. Then position the Sensor O-ring and insert the Rail Sensor into its mounting location.
2. Insert the new sleeve O-rings, new steel sleeves and cap-screws into the sensor mounting holes.
3. Using a 5/16" wrench, install and tighten the capscrews to 21-27 lbs. in. (2.4-3.1 N•m).
4. Reconnect the Transmission Harness to the Rail Select Sensor.

### Final Check

Make sure that the capscrews are tightened to specification.

Make sure that the sensor connections are secure.

### Calibration

To operate properly, the system must be calibrated as follows:

- a. Turn the ignition switch to ON and allow the transmission to power up.
- b. Turn the ignition switch to OFF and wait two minutes.

**IMPORTANT:** The shifter module must be calibrated before the vehicle is placed into operation.

**1**  
Insert Rail  
Select Sensor

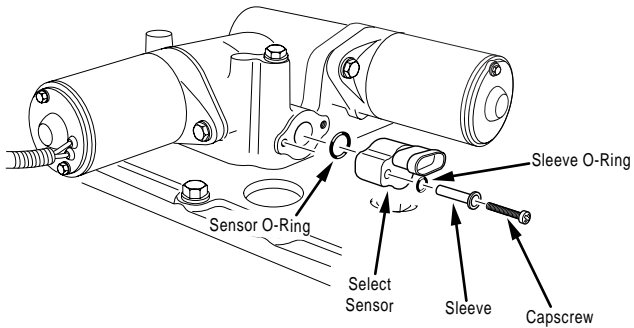

**2**  
Attach Mounting  
Capscrews

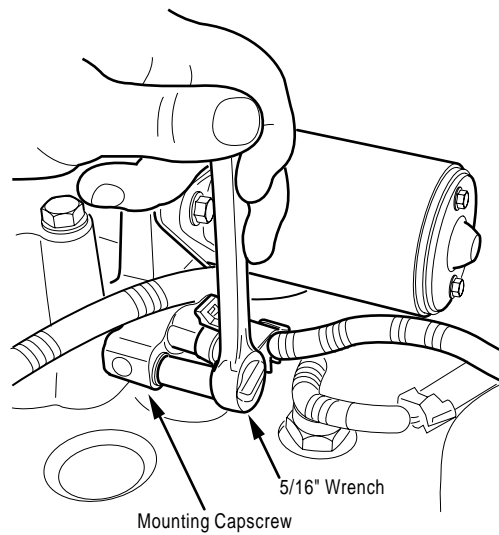

**3**  
Reconnect Transmission  
Harness to Sensor

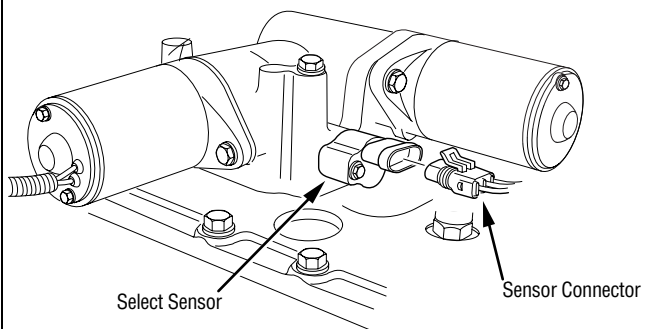

---

**Solo Heavy Duty Clutch - Install, Con't**

## Gear Select Sensor - Overview

### Special Instructions

Install the sensor with the connector on top.

While removing the capscrews, hold the sensor in place.  
Don't allow it to snap out of position.

### Required Tools

- Basic Hand Tools.

### Essential Steps

The shifter module must be calibrated before the vehicle is placed into operation.

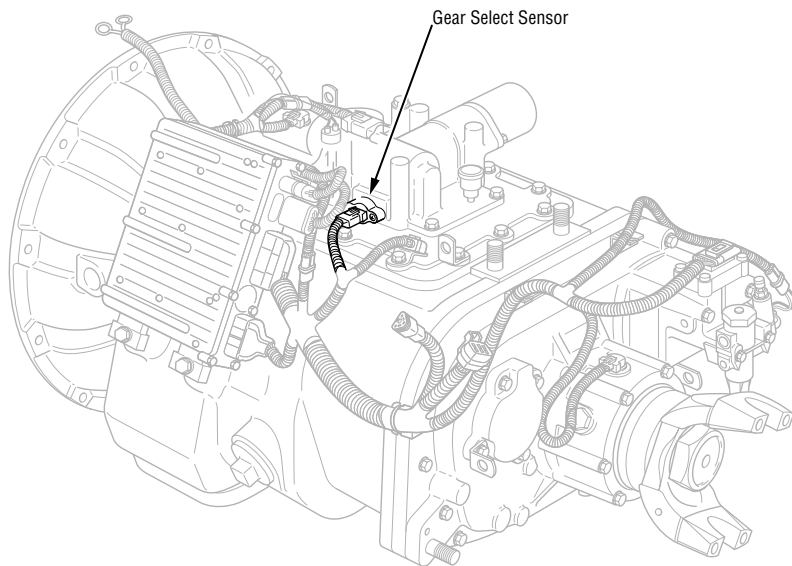

---

## How to Remove the Gear Select Sensor

### Procedure-

1. Remove nylon cable ties from motor wires.
2. Disconnect the Transmission Harness from the Gear Select Sensor and Rail Select Sensor.
3. Disconnect the Gear Select Motor and Rail Select Motor from the Transmission ECU.
4. Using a 5/16" wrench, remove the four (4) Electric Shifter capscrews.
5. Remove the Electric Shifter and gasket.
6. Turn the shifter over (upside down).
7. Using a 5/16" wrench, remove the two (2) Gear Select Sensor capscrews.
8. Carefully allow the sensor to rotate (not snap) to a relaxed position, then remove the sensor, steel sleeves and O-ring from the housing.
9. Insert your finger into the sensor bore and push the arm slightly.

1

Disconnect Transmission Harness from Rail and Gear Select Sensor

Sensor Connectors

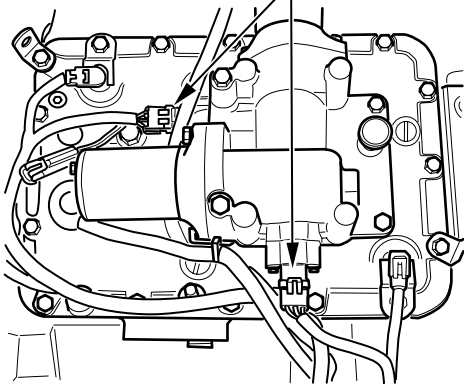

2

Disconnect Rail Motor and Gear Motor from Transmission ECU

Motor Connectors

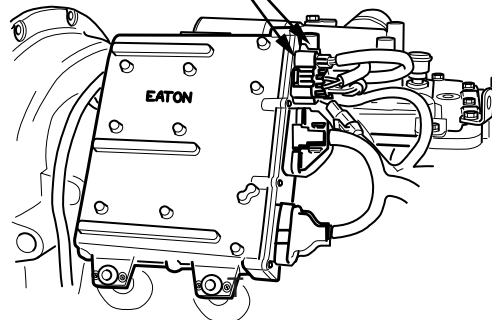

3

Remove Mounting Capscrews

9/16" Wrench

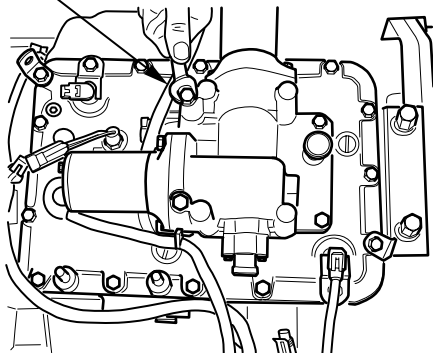

4

Remove Electric Shifter and Gasket

Electric Shifter

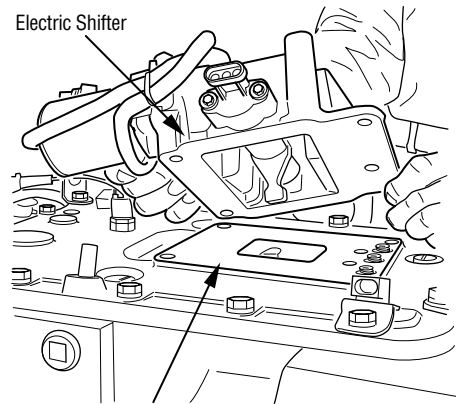

5

Remove Gear Select Sensor

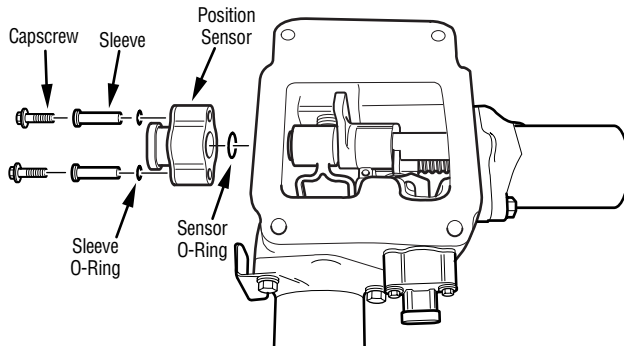

## How to Install the Gear Select Sensor

### Procedure-

1. Using a screwdriver, push and hold the Gear Select bushing inside the Shift Bar Housing toward the outside of the housing.
2. While holding the bushing in place, align the sensor tab with the slot and insert the Gear Select Sensor into the shift shaft.

**Note:** Install the sensor with the connector toward the top of the Shifter Housing

3. Insert the new steel sleeves, O-rings and capscrews into the sensor mounting holes.
4. Using a 5/16" wrench, install and tighten the two (2) capscrews to 21-27 lbs. in. (2.4-3.1 N•m).
5. Clean and remove old gasket material from the Shift Bar Housing.
6. Position a new gasket at the Shift Bar Housing mounting location.

**Note:** Check to make sure that the shift blocks are in the neutral position.

7. Move the shift finger in the Electric Shifter to the center (Neutral) position.

**Note:** If the shift finger is not properly aligned, the Electric Shifter will not fit properly at its mounting location.

8. Position the Electric Shifter on the Shift Bar Housing.
9. Using a 9/16" wrench, install and tighten the four (4) capscrews to 35-45 lbs. ft. (47.5-61.0 N•m).
10. Reconnect the Rail Select Motor to the Transmission ECU.
11. Reconnect the Gear Select Motor to the Transmission ECU.
12. Reconnect the Transmission Harness to the Rail Select Sensor and Gear Select Sensor.
13. Use nylon cable ties to secure the motor wires to the transmission.

### Final Check

Make sure the capscrews are tightened to specification.

Make sure all connections are tight.

### Calibration

To operate properly, the system must be calibrated as follows:

- a. Turn the ignition switch to ON and allow the transmission to power up.
- b. Turn the ignition switch to OFF and wait two minutes.

**IMPORTANT**The shifter module must be calibrated before the vehicle is placed into operation.

**1**  
Install Gear  
Select Sensor

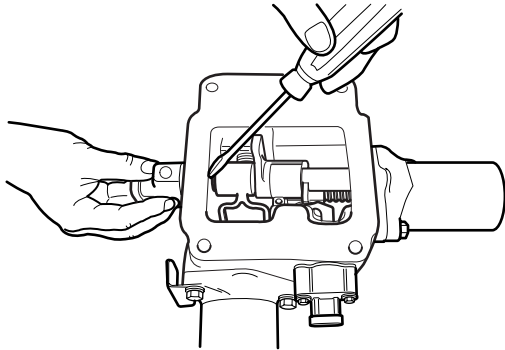

**2**  
Install Electric  
Shifter

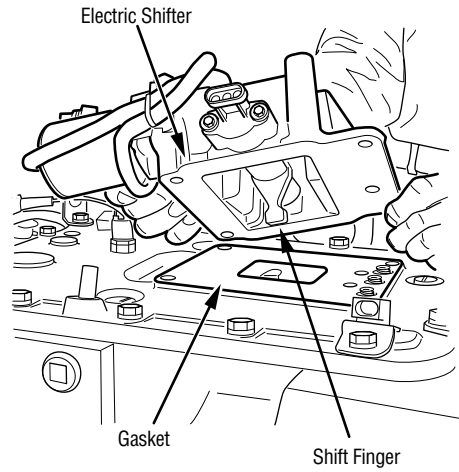

**3**  
Install Mounting  
Capscrews

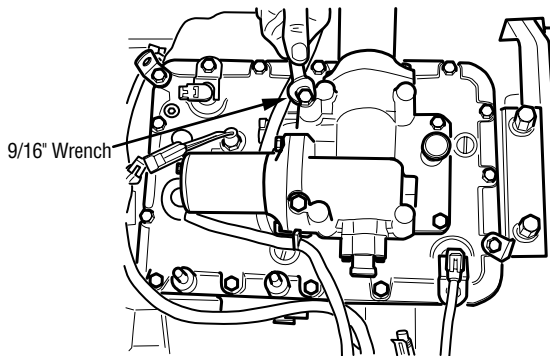

**4**  
Reconnect Rail  
and Gear Select Motors to  
Transmission ECU

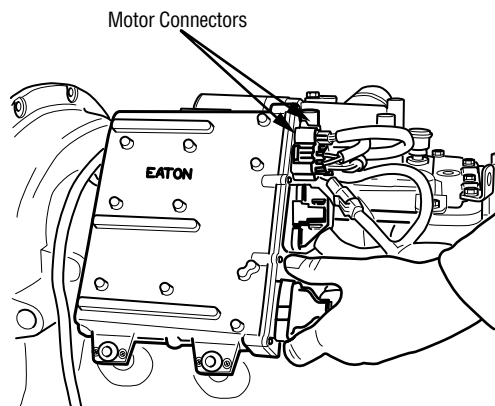

**5**  
Reconnect Transmission Harness  
to Rail and Gear Select Sensors

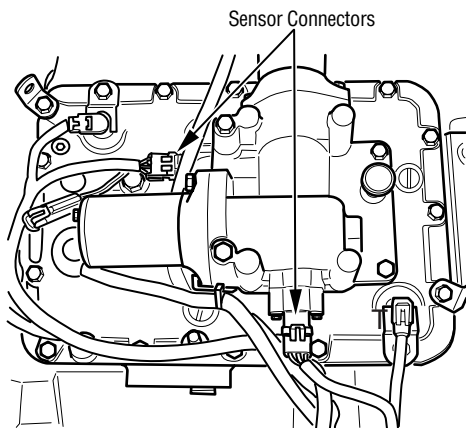



---

**Solo Heavy Duty Clutch - Install, Con't**

## Input/Main Shaft Speed Sensors - Overview

### Special Instructions

Use care when installing the O-ring.

Lubricate the O-ring with Eaton/fuller silicone #71214 or equivalent.

### Required Tools

- Basic Hand tools.

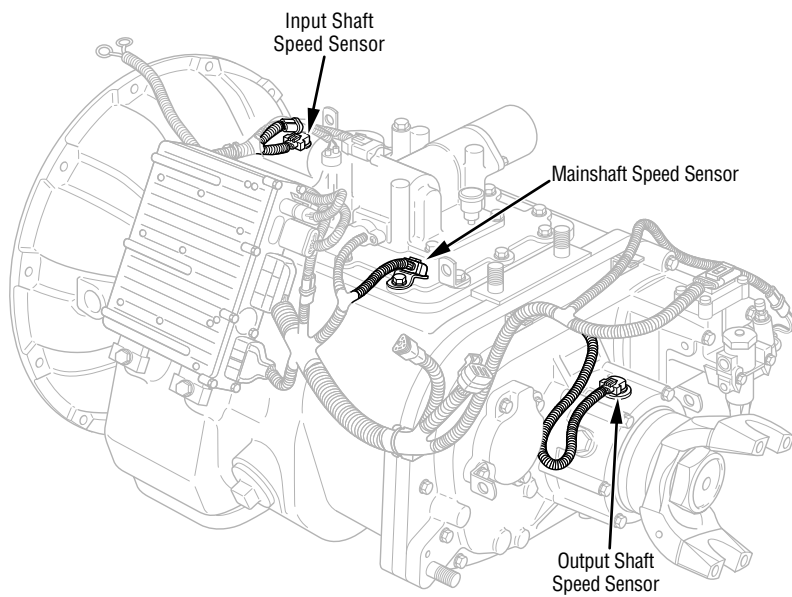

---

## How to Remove the Input/Main Shaft Speed Sensors

### Procedure-

1. Disconnect the Transmission Harness from the Speed Sensor.
2. Remove the rubber cap from the retaining bolt.  
**Note:** This cap is installed during manufacturing. It is NOT necessary to replace it.
3. Using a 9/16" wrench, remove the sensor retaining bolt.
4. Remove the spring clip.
5. Remove the Speed Sensor, with O-ring, from the transmission housing.

**1**  
Disconnect  
Transmission Harness  
and Sensor Cap

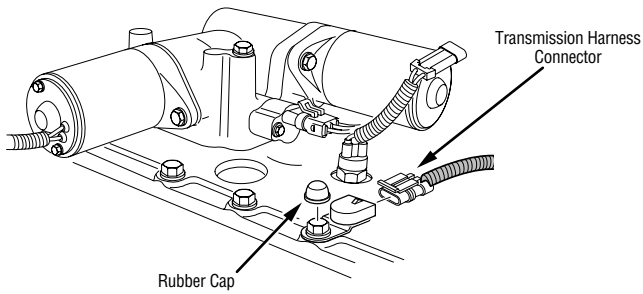

**2**  
Remove Speed  
Sensor Retaining Bolt,  
Spring Clip, Speed Sensor  
and O-Ring

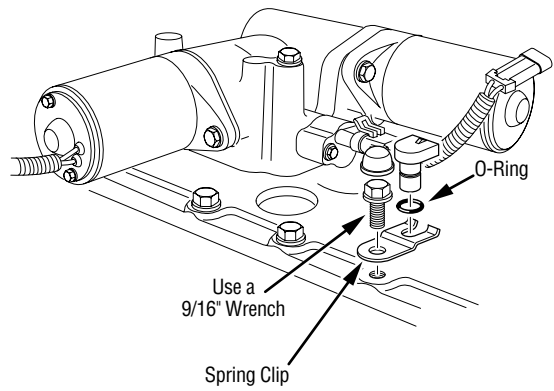

---

## How to Install the Input/Main Shaft Speed Sensor

### Procedure-

1. Using a smooth, twisting motion, fully insert the Speed Sensor in the transmission housing opening.
2. Install the spring clip.
3. Using a 9/16" wrench, install and tighten the retaining bolt to 35-45 lbs. ft. (47.5-61.0 N•m).
4. Reconnect the Transmission Harness to the Speed Sensor.

### Final Check

Make sure the retaining bolt is properly tightened.

Make sure the Transmission Harness is properly connected to the Speed Sensor.

### Calibration

None.

1

Install O-ring, Speed Sensor, Spring Clip, and Retaining Bolt

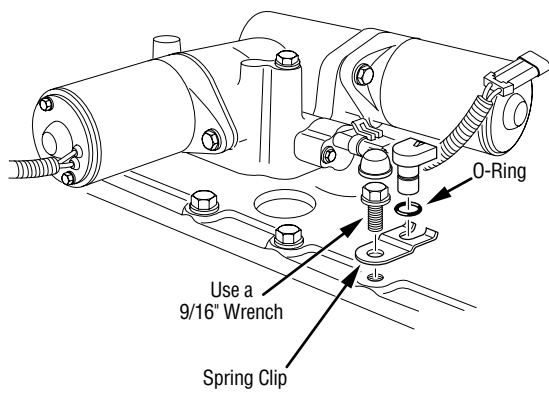

2

Reconnect Transmission Harness

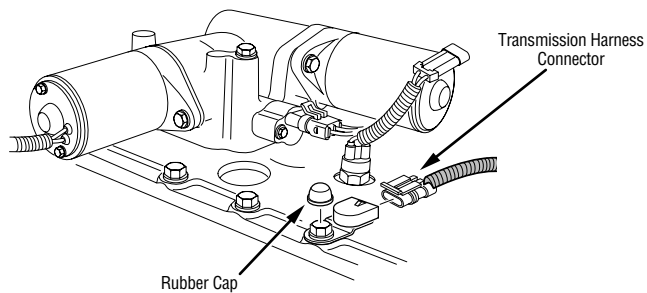

---

**Solo Heavy Duty Clutch - Install, Con't**

## Output Shaft Speed Sensor - Overview

### Special Instructions

Use extra care when installing the O-ring.

Lubricate the O-ring with Eaton/Fuller silicone #71214 or equivalent.

### Required Tools

- Basic Hand Tools.

### Essential Steps

Make sure the retaining bolt is properly tightened.

Make sure the Transmission harness is properly connected to the Speed Sensor.

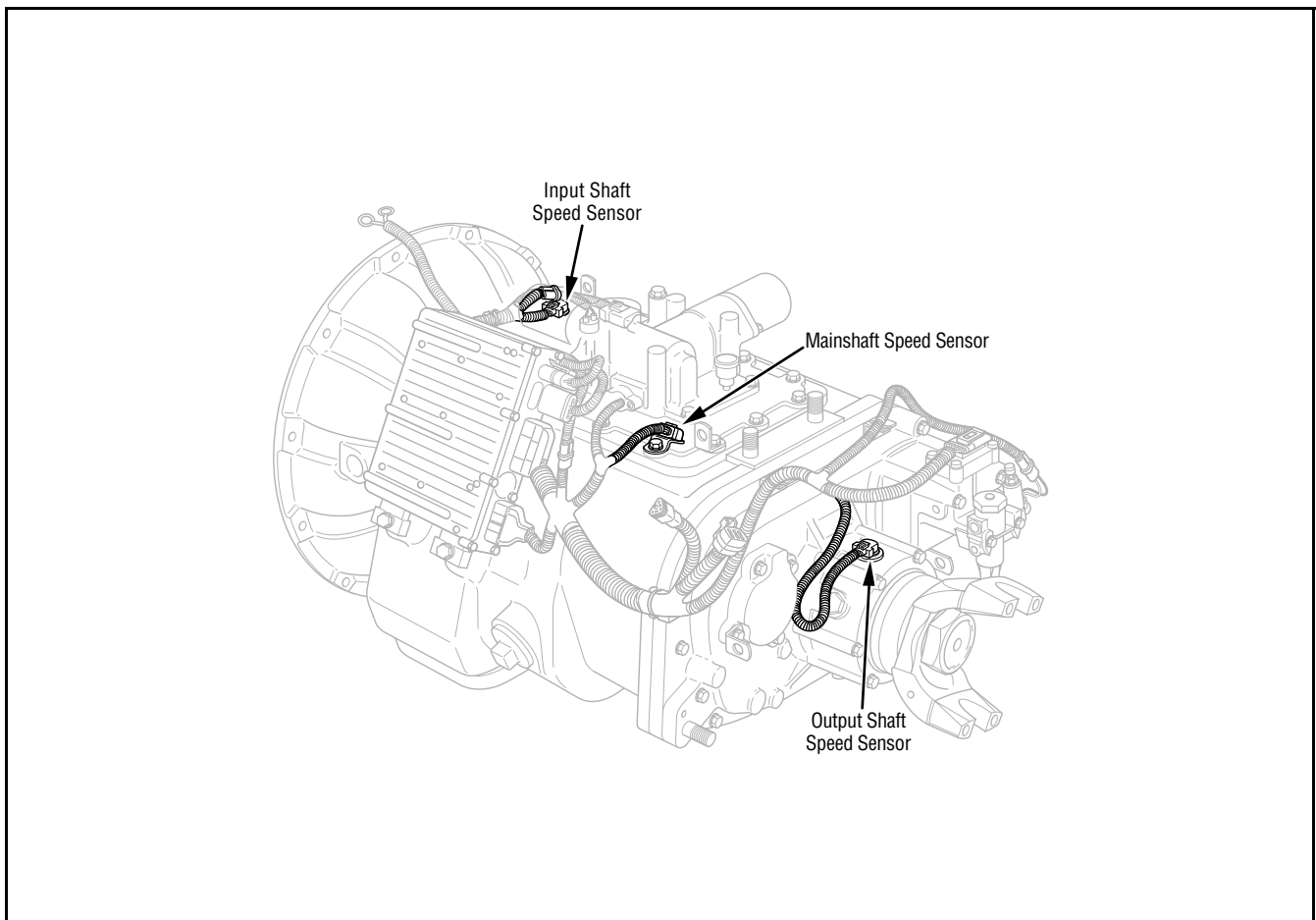



## **How to Remove the Output Shaft Speed Sensor**

### **Procedure-**

1. Disconnect the Transmission Harness from the Speed Sensor.
2. Using a 9/16" wrench, remove the sensor retaining bolt.
3. Remove the Speed Sensor, with O-ring, from the transmission housing.

**1**  
Disconnect  
Transmissin Harness

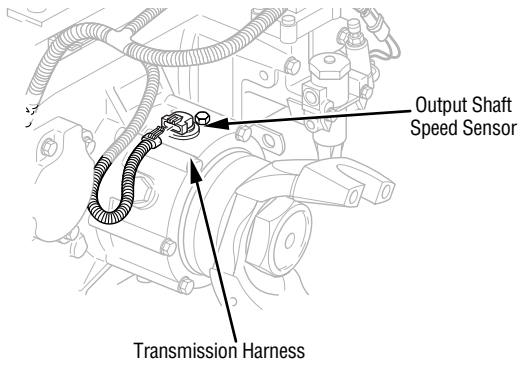

**2**  
Remove Retaining Bolt,  
Speed Sensor  
and O-ring

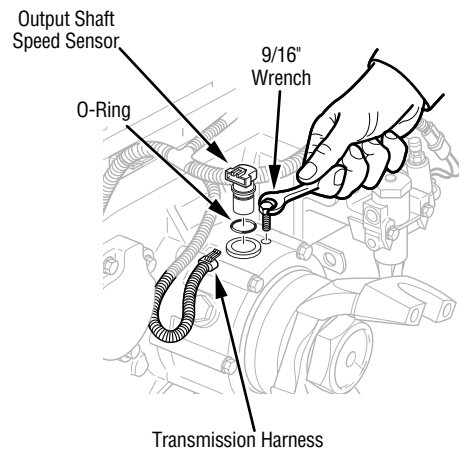

---

## How to Install the Output Shaft Speed Sensor

### Procedure-

1. Using a smooth, twisting motion, fully insert the Speed Sensor in the transmission housing opening.
2. Using a 9/16" wrench, install and tighten the retaining bolt to 35-45 lbs. ft. (47.5-61.0 N•m).
3. Reconnect the Transmission Harness to the Speed Sensor.

### Final Check

Make sure the retaining bolt is properly tightened.

Make sure the Transmission Harness is properly connected to the Speed Sensor.

### Calibration

None.

**1**  
Install O-ring,  
Speed Sensor  
and Retaining Bolt

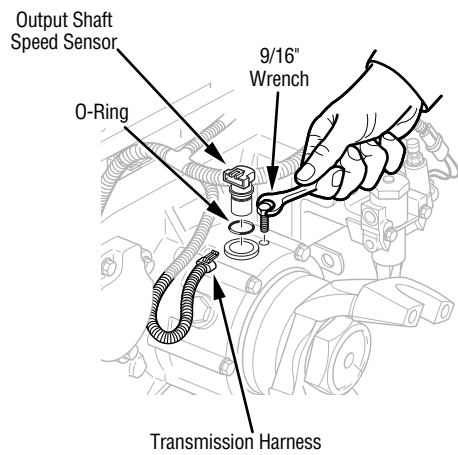

**2**  
Reconnect  
Transmission Harness

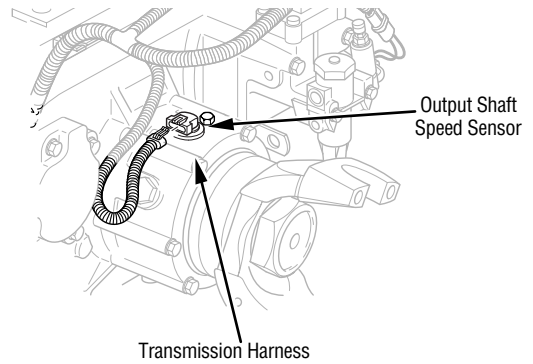

---

**Solo Heavy Duty Clutch - Install, Con't**

## Range Valve - Overview

### Special Instructions

Do not use a hammer to loosen the Range Valve in the housing.

Use caution when installing O-rings.

Lubricate O-rings with Eaton/Fuller silicone #71214 or equivalent.

### Required Tools

- Basic Hand Tools.

### Essential Steps

None.

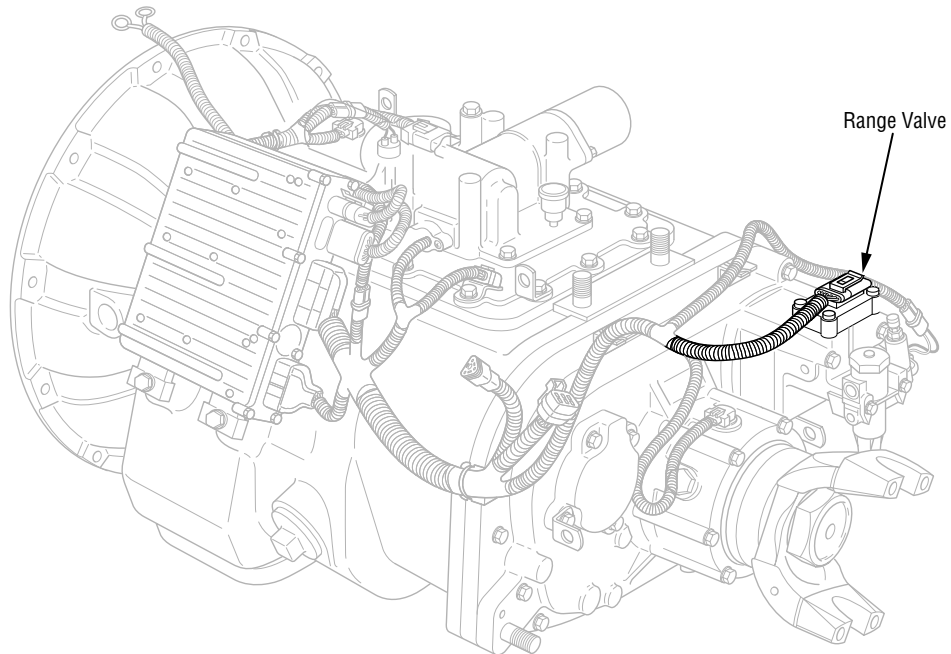

---

## **How to Remove the Range Valve**

### **Procedure-**

1. Relieve system air pressure by disconnecting vehicle air supply from the Air Filter/Regulator.
2. Disconnect the Transmission Harness from the Range Valve assembly.
3. Using a 5/16" wrench, remove the four (4) Range Valve capscrews.
4. Lift and remove the Range Valve from the transmission housing.

**1**  
Disconnect  
Transmission  
Harness

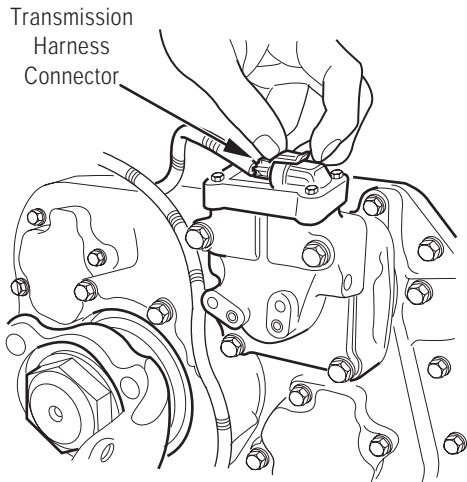

**2**  
Remove Mounting  
Capscrews

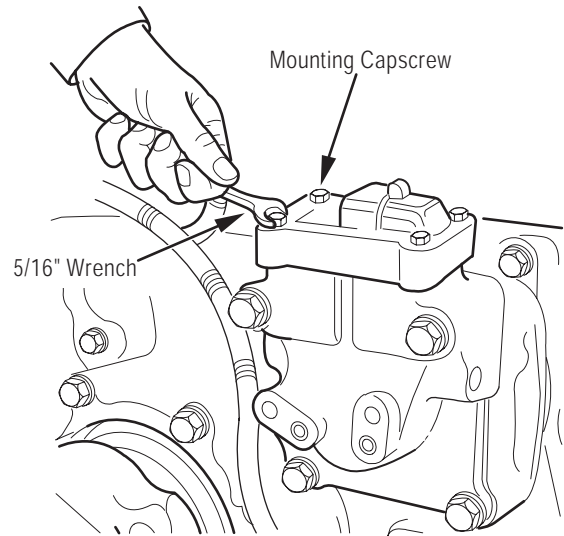

**3**  
Remove  
Range Valve  
from Housing

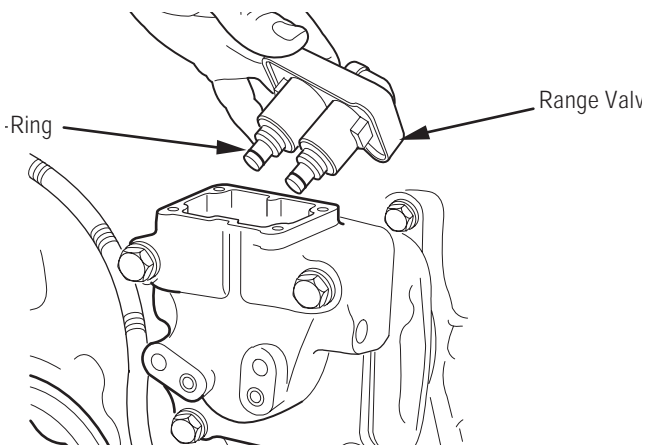



---

## How to Install the Range Valve

### Procedure-

1. Install and push the Range Valve down into the transmission housing.

**Note:** The valve is keyed to fit its mounting location. Take care to align the slot in the valve with the slot in the transmission housing.

2. Using a 5/16" wrench, install and tighten the four (4) capscrews to 21-27 lbs. in. (2.4-3.1 N•m).
3. Reconnect the Transmission Harness to the Range Valve.
4. Reconnect the air supply to the Air Filter/Regulator.

### Final Check

Make sure that the capscrews are tightened to specification.

Make sure the Transmission Harness is connected and locked.

### Calibration

None.

**1**  
Install  
Range Valve

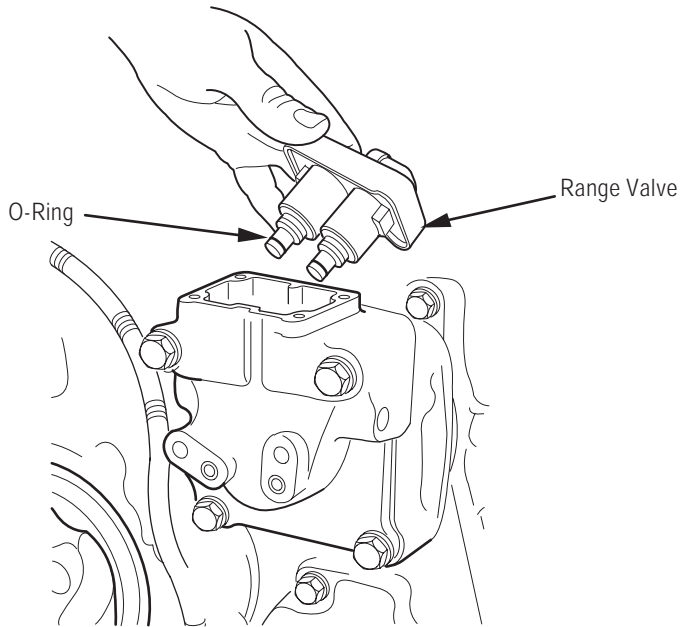

**2**  
Install Mounting  
Capscrews

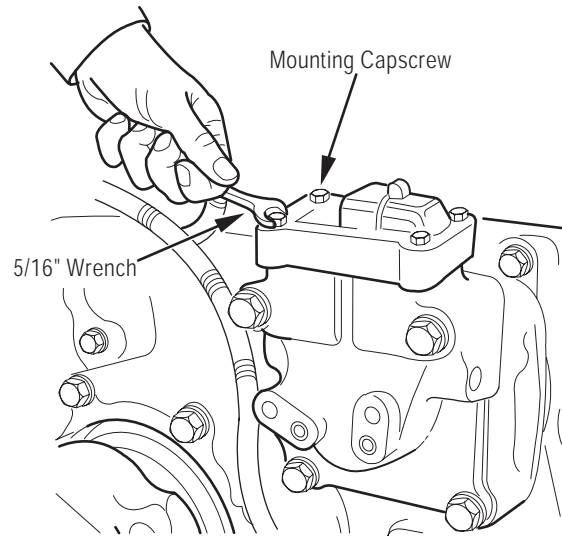

**3**  
Reconnect  
Transmission  
Harness

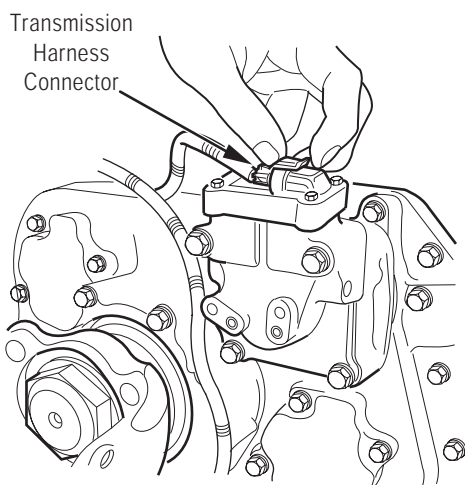

---

**Solo Heavy Duty Clutch - Install, Con't**

## Splitter Valve - Overview

### Special Instructions

Do not use a hammer to loosen the Splitter Valve in the housing.

Use caution when installing O-rings.

Lubricate O-rings with Eaton/Fuller silicone #71214 or equivalent.

### Required Tools

- Basic Hand Tools.

### Essential Steps

None.

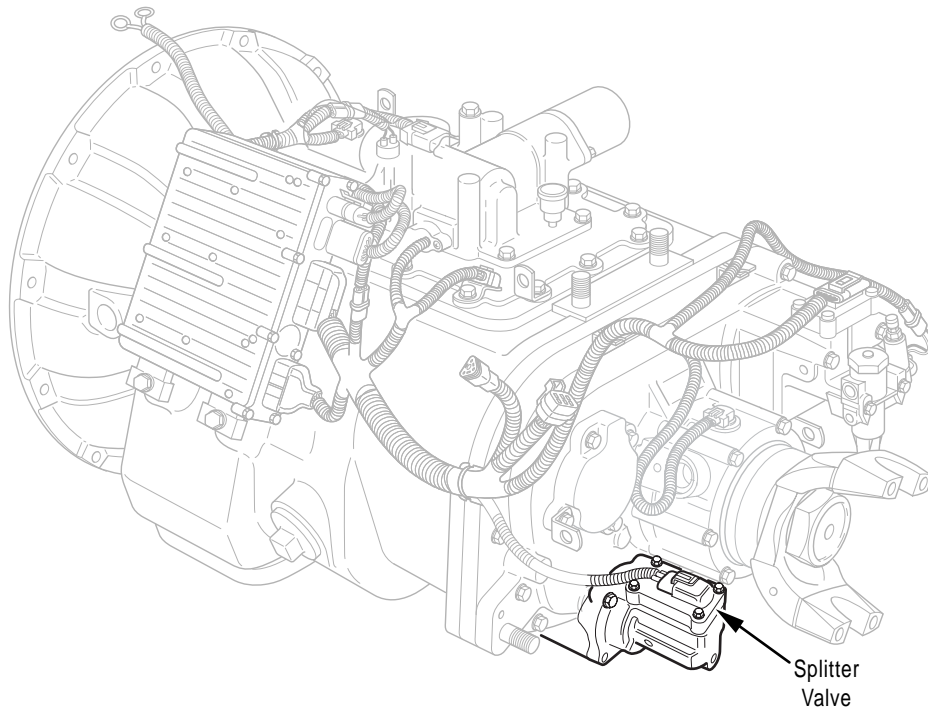

---

## **How to Remove the Splitter Valve**

### **Procedure-**

1. Relieve system air pressure by disconnecting vehicle air supply from the Air Filter/Regulator.
2. Disconnect the Transmission Harness from the Splitter Valve.
3. Using a 5/16" wrench, remove the four (4) Splitter Valve capscrews.
4. Lift and remove the Splitter Valve from the transmission housing.

**1**  
Disconnect  
Transmission  
Harness

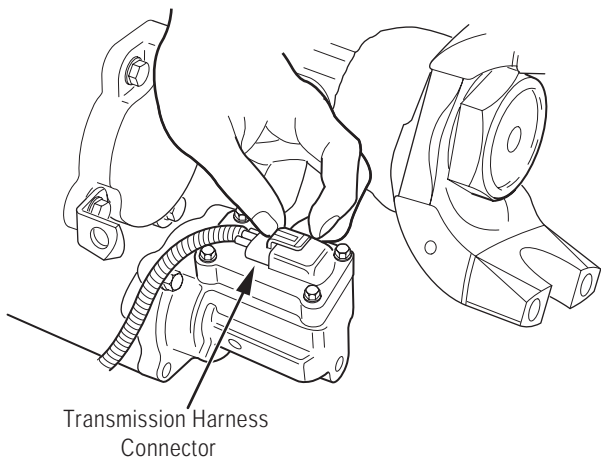

**2**  
Remove Mounting  
Capscrews

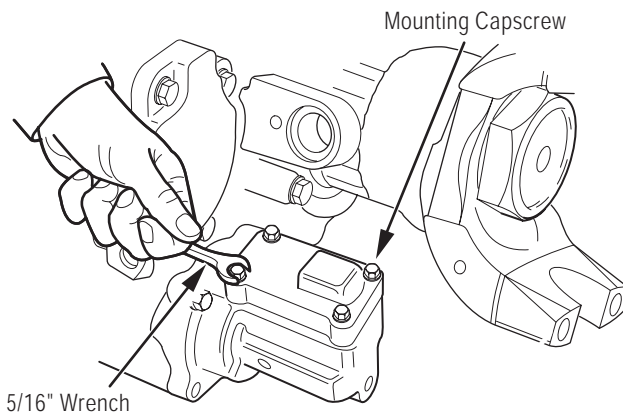

**3**  
Remove  
Splitter Valve  
from Housing

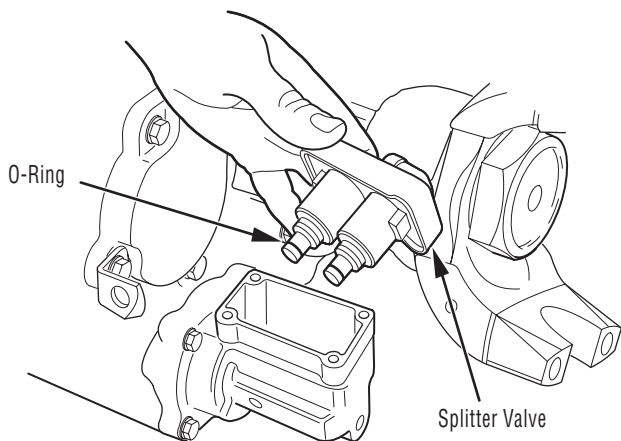

Service Procedure

---

## How to Install the Splitter Valve

### Procedure-

1. Install and push the Splitter Valve down into the transmission housing.  
  
**Note:** The valve is keyed to fit its mounting location. Take care to align the slot in the valve with the slot in the transmission housing.
2. Using a 5/16" wrench, install and tighten the four (4) capscrews to 21-27 lbs. in. (2.4-3.1 N•m).
3. Reconnect the Transmission Harness to the Splitter Valve.
4. Reconnect the air supply to the Air Filter/Regulator.

### Final Check

Make sure the capscrews are properly tightened.

Make sure the Transmission Harness is connected and locked.

### Calibration

None.

**1**  
Install  
Splitter Valve

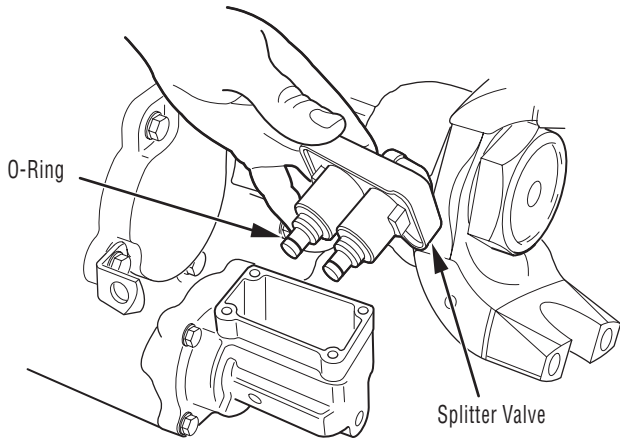

**2**  
Install Mounting  
Capscrews

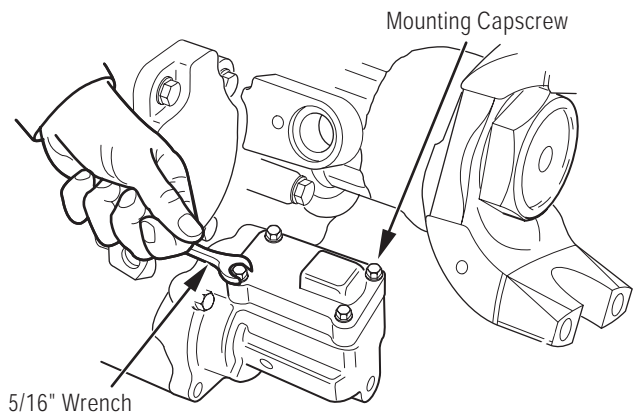

**3**  
Reconnect  
Transmission  
Harness

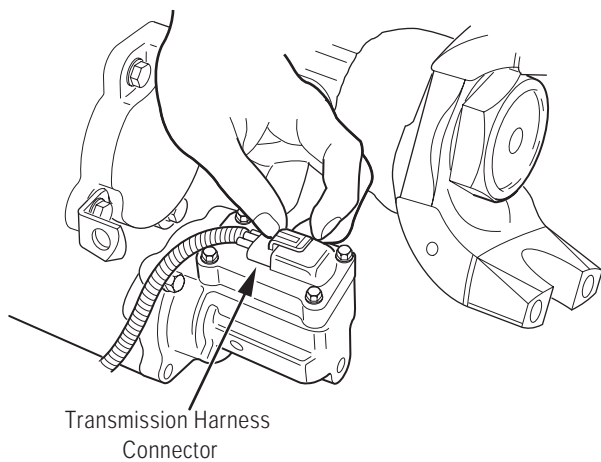



---

**Solo Heavy Duty Clutch - Install, Con't**

## Air Filter/Regulator - Overview

### Special Instructions

The Air Filter/Regulator has two (2) O-rings located between the filter/regulator and the Range Cylinder Cover..

Lubricate the O-rings with Eaton/Fuller Silicone #71214 or equivalent

### Required Tools

- Basic Hand Tools.

### Essential Steps

None.

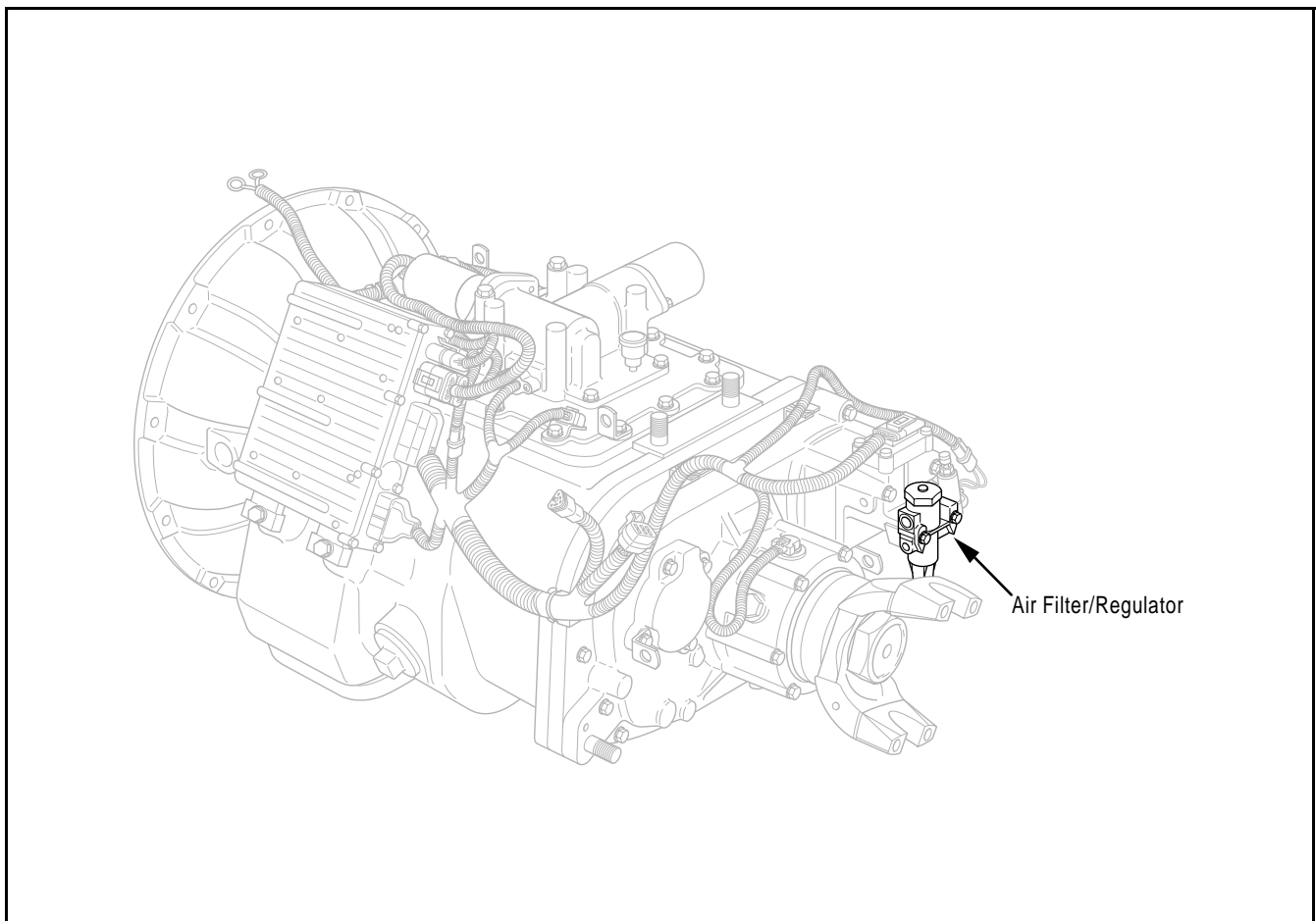

---

## **How to Remove the Air Filter/Regulator**

### **Procedure-**

1. Relieve system air pressure by disconnecting vehicle air supply from the Air Filter/Regulator.
2. Using a 7/16" wrench, remove the two (2) capscrews.
3. Remove the Air Filter/Regulator assembly.
4. Remove the two (2) O-rings from the recesses in the Range Cylinder Cover.

**1**  
Remove Capscrews

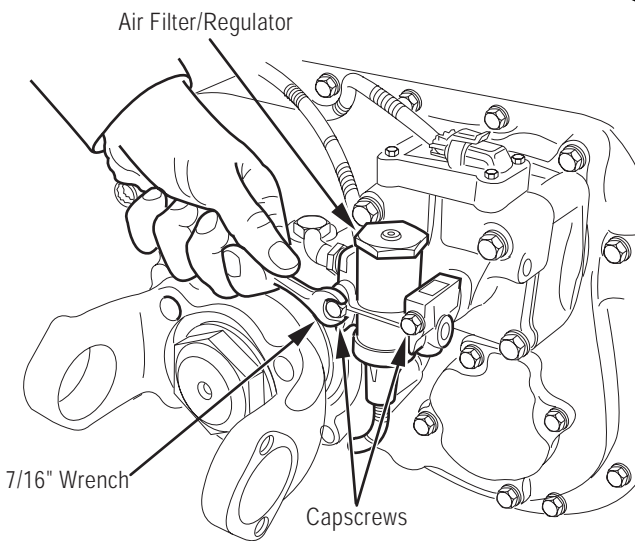

**2**  
Remove O-Rings

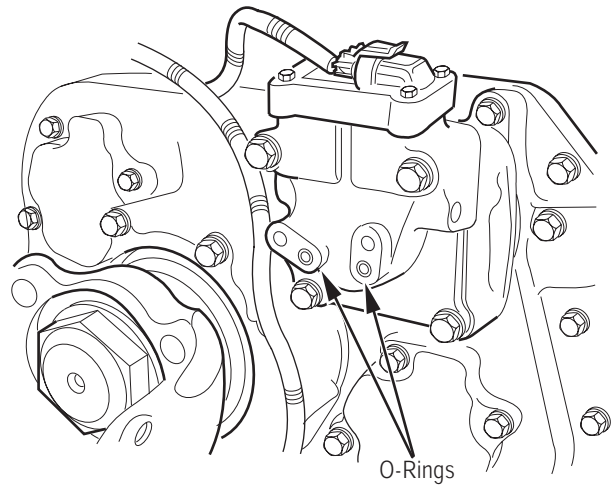

---

## How to Install the Air Filter/Regulator

### Procedure-

1. Press the O-rings into the recesses in the Range Cylinder Cover.
2. Apply Eaton/Fuller sealant #71205 or equivalent to the two (2) retaining capscrews.
3. Insert the capscrews into the Air Filter/Regulator mounting holes.
4. Position the Air Filter/Regulator over the o-rings.
5. Using a 7/16" wrench, install and tighten the two (2) capscrews to 8-12 lbs. ft. (10.8-16.3 N•m).
6. Reconnect the air supply to the Air Filter/Regulator.

### Final Check

Make sure that the capscrews are properly tightened.

Make sure that all air supply fittings are tight.

### Calibration

None.

1

Position O-Rings

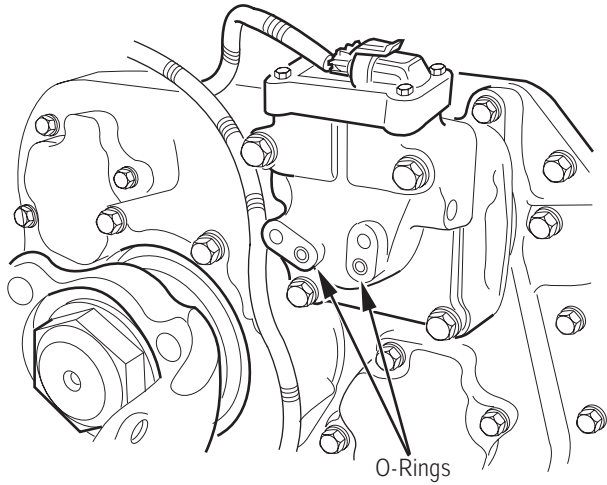

2

Tighten Capscrews

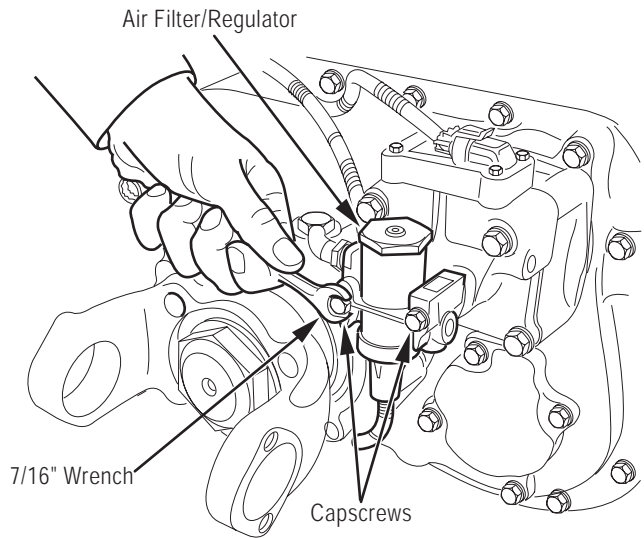

---

**Solo Heavy Duty Clutch - Install, Con't**

## Inertia Brake Solenoid - Overview

### Special Instructions

The Air Filter/Regulator must be removed before removing the Inertia Brake Solenoid. See “Air Filter/Regulator - Overview” on page 54.

Make sure the two (2) O-rings between the Air Filter/Regulator and the Range Cylinder Cover are properly positioned during reassembly.

Apply the thread sealer (Eaton #71205) to all air connections before assembly.

### Required Tools

- Basic Hand Tools.

### Essential Steps

None.

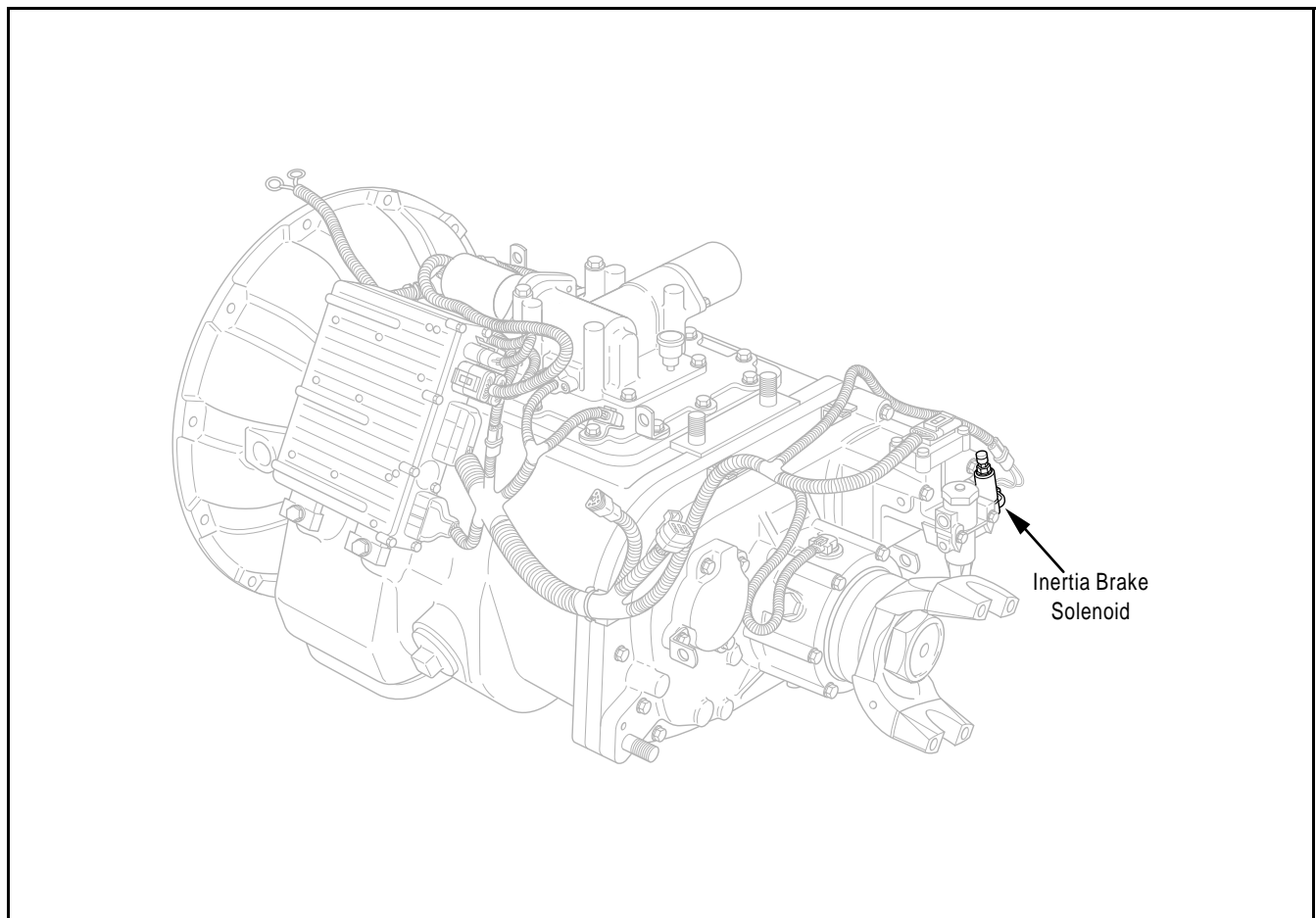



---

## How to Remove the Inertia Brake Solenoid

### Procedure-

1. Relieve system air pressure by disconnecting vehicle air supply from the Air filter/Regulator.
2. Disconnect the Transmission Harness from the Inertia Brake Solenoid.
3. Using a 5/8" wrench, disconnect the air from the Inertia Brake end (swivel end).
4. Using a 3/4" wrench, disconnect the air line at the solenoid.
5. Using a 7/16" wrench, remove the Air filter/Regulator, with the solenoid attached from the Range Cylinder Cover.

**Note:** Remove and Inspect the two (2) O-rings from the recesses in the Range Cylinder Cover.

6. Remove the Inertia Brake Solenoid from the Air filter/Regulator.
7. Using a 9/16" wrench, remove the 1/8" 90° elbow from the Inertia Brake Solenoid and save it for installation on the new solenoid.
8. Using a 7/16" wrench, remove the 1/8" pipe nipple from the Inertia Brake Solenoid and save for installation on the solenoid.

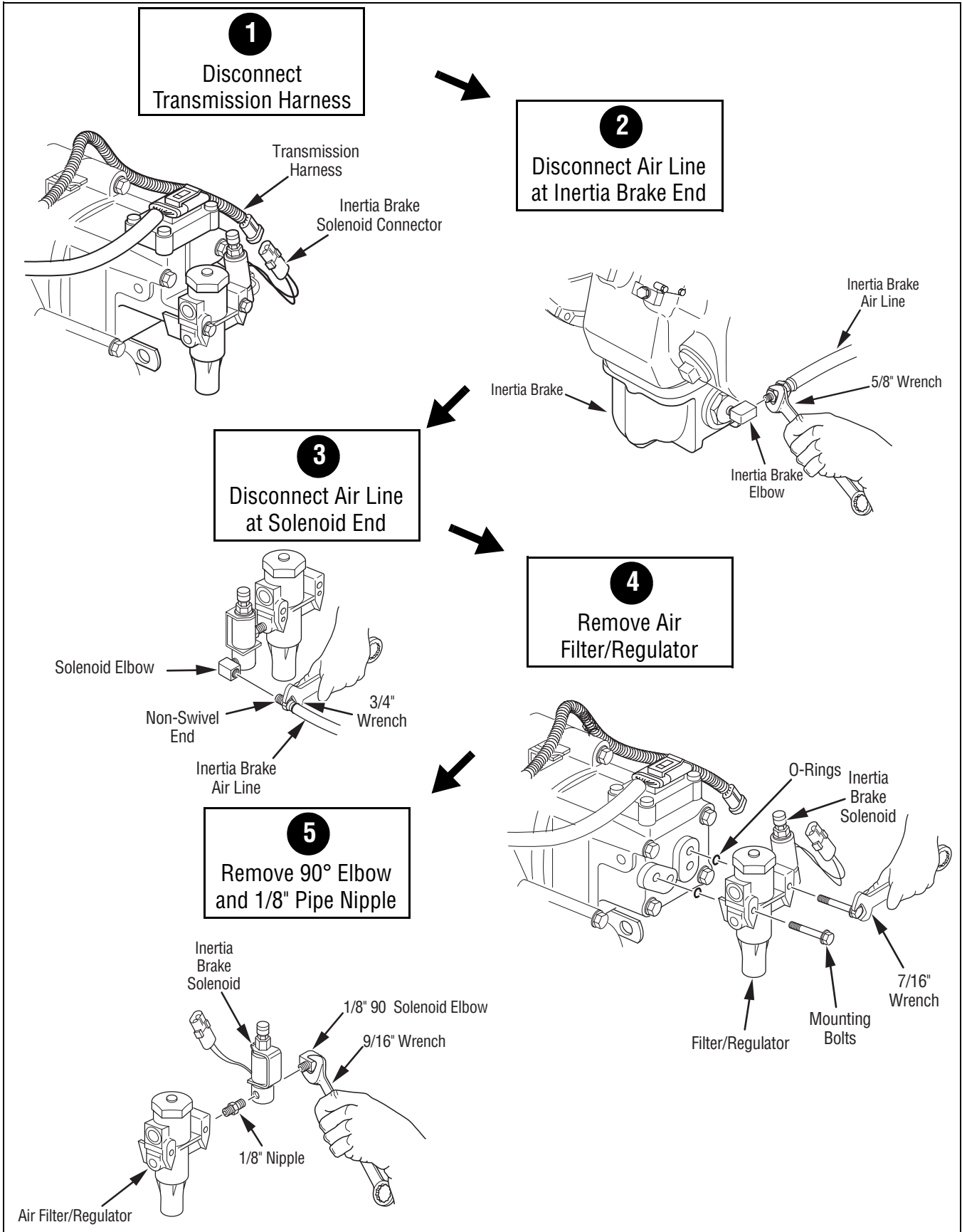

Service Procedure

**Inertia Brake Solenoid Removal**

---

## How to Install the Inertia Brake Solenoid

### Procedure-

1. Using a 9/16" wrench, install the 90° elbow onto the Inertia Brake Solenoid and tighten.

**Note:** Align the elbow to face the front of the transmission.

2. Using a 9/16" wrench, install the Inertia Brake Solenoid onto the Air Filter/Regulator with a pipe nipple and tighten.
3. Press the O-rings into the recesses in the Range Cylinder Cover.
4. Apply Eaton/Fuller sealant #71205 or equivalent to the two (2) retaining capscrews.
5. Insert the capscrews into the Air Filter/Regulator mounting holes.
6. Position the Air Filter/Regulator over the o-rings.
7. Using a 7/16" wrench, install and tighten the two (2) capscrews to 8-12 lbs. ft. (10.8-16.3 N•m).
8. Using a 3/4" wrench, reconnect the non-swivel end of the air line to the solenoid elbow fitting and tighten.
9. Using a 5/8" wrench, reconnect the swivel end of the air line to the Inertia Brake elbow fitting and tighten.
10. Reconnect the Transmission Harness to the Inertia Brake Solenoid.
11. Secure the air line and electrical harness as required with nylon cable ties.
12. Reconnect the air supply to the Air Filter/Regulator.

### Final Check

Make sure the capscrews are properly tightened.

Make sure the air connections are tight.

Make sure the solenoid connector is properly connected to the Transmission Harness.

### Calibration

None.

1

Install 90° Elbow,  
pipe Nipple,  
and Solenoid

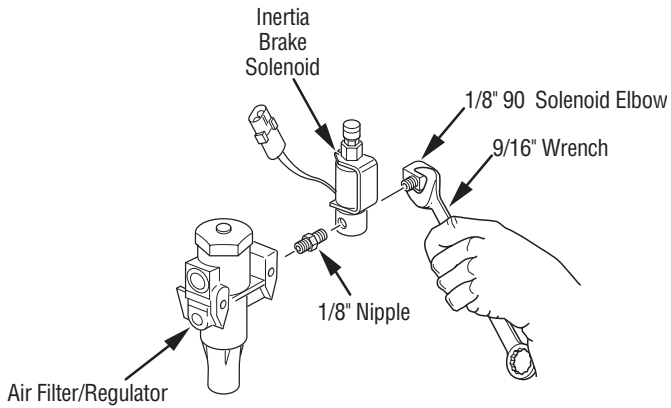

2

Install Air  
Filter/Regulator

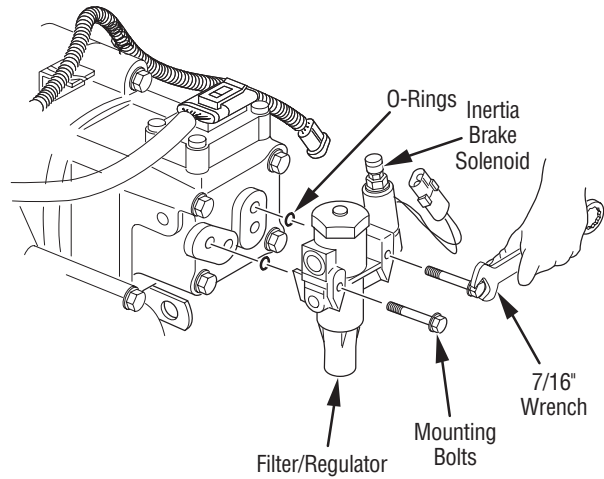

3

Reconnect Air Line  
at Solenoid End

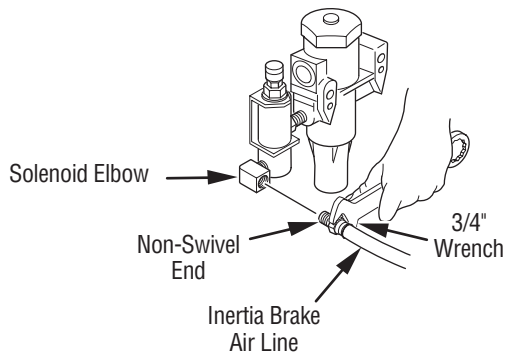

4

Reconnect Air Line  
at Inertia Brake End

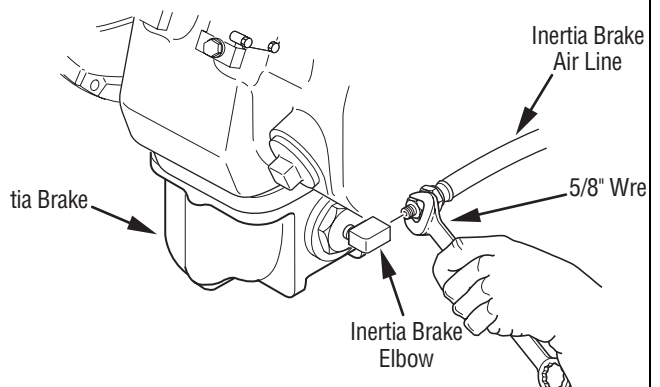

5

Reconnect  
Transmission Harness

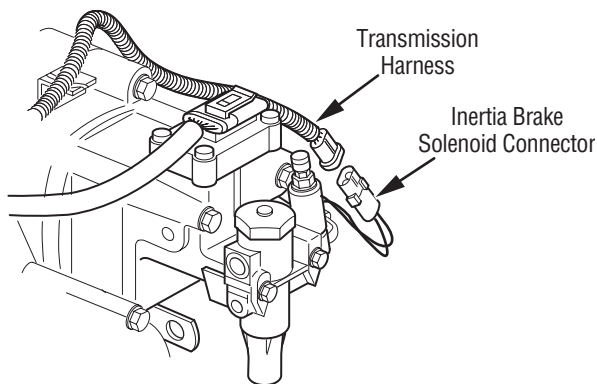

---

**Solo Heavy Duty Clutch - Install, Con't**

## Inertia Brake - Overview

### Special Instructions

Be sure to use sealing type washers on the mounting bolts.

Apply Eaton #71205 thread sealer to all air connections before assembly.

The Inertia Brake is mounted with two (2) longer mounting bolts (ends) and four (4) shorter mounting bolts (sides).

### Required Tools

- Basic Hand Tools.

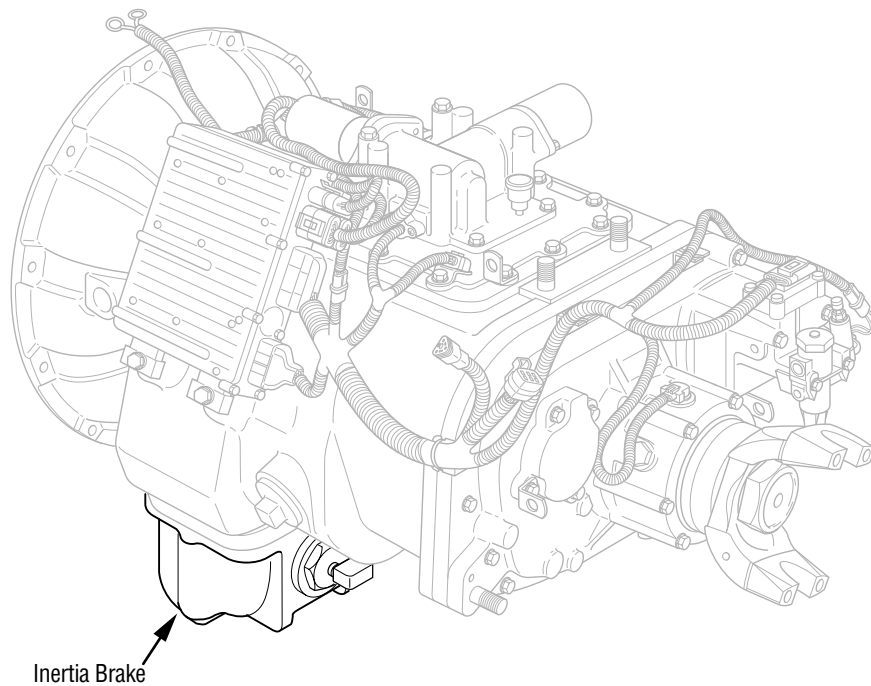

---

## How to Remove the Inertia Brake

### Procedure-

1. Drain the lubricant from the transmission.

**Note:** The Inertia Brake will still contain some lubricant.

2. Using a 5/8" wrench, disconnect the Inertia Brake air line from the 90 elbow.
3. Using a 9/16" wrench, remove the six (6) mounting bolts, with sealing washers, from the Inertia Brake.
4. Remove the Inertia Brake and gasket from the transmission.
5. Using a 9/16" wrench, remove the 90 elbow from the Inertia Brake.

**1**  
Drain Transmission  
Lubricant

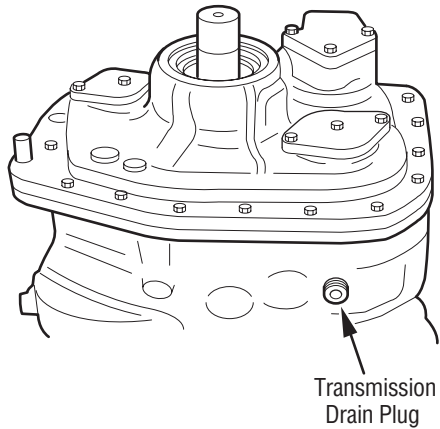

**2**  
Disconnect Inertia  
Brake Air Line

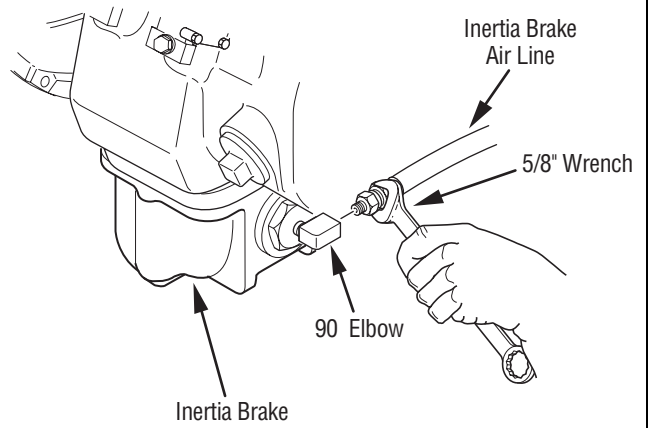

**3**  
Remove Mounting  
Bolts, Inertia Brake,  
Gasket, and 90° Elbow

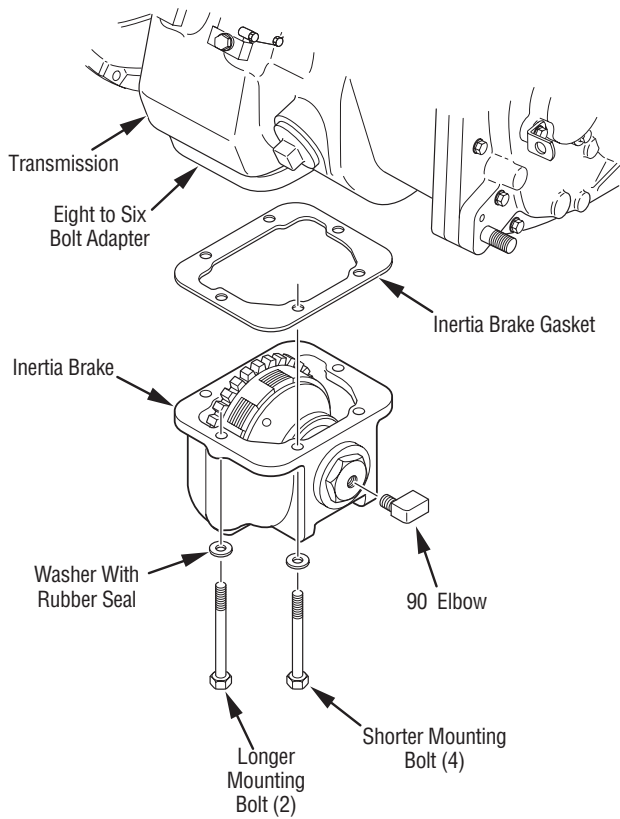



---

## How to Install the Inertia Brake

### Procedure-

1. Clean and remove all old gasket material from the mating surfaces of the Inertia Brake and the transmission.
2. Using a 9/16" wrench, install the 90 elbow to the Inertia Brake and tighten.
3. Install the Inertia Brake being careful to align the Inertia Brake gear with the 47-tooth PTO drive gear.
4. Using a 9/16" wrench, install the four (4) shorter mounting bolts with sealing washers and two (2) longer mounting bolts with the sealing washers. Tighten mounting bolts to 35-45 lbs. ft. (47.5-61.0 N•m).

**Note:** The longer mounting bolts go on the ends of the Inertia Brake. The shorter bolts go on the sides of the Inertia Brake.

5. Using a 5/8" wrench, reconnect the air line to the 90 elbow on the Inertia Brake and tighten.
6. Using nylon cable ties, secure the air line as required.
7. Fill the transmission with lubricant.

### Final Check

Make sure the mounting bolts are properly tightened.

Make sure the air fittings are properly tightened.

Make sure the transmission is properly filled with lubricant.

Check for lubricant leaks after operating the vehicle.

### Calibration

None.

1

Install 90° Elbow,  
Inertia Brake, Gasket  
and Mounting bolts

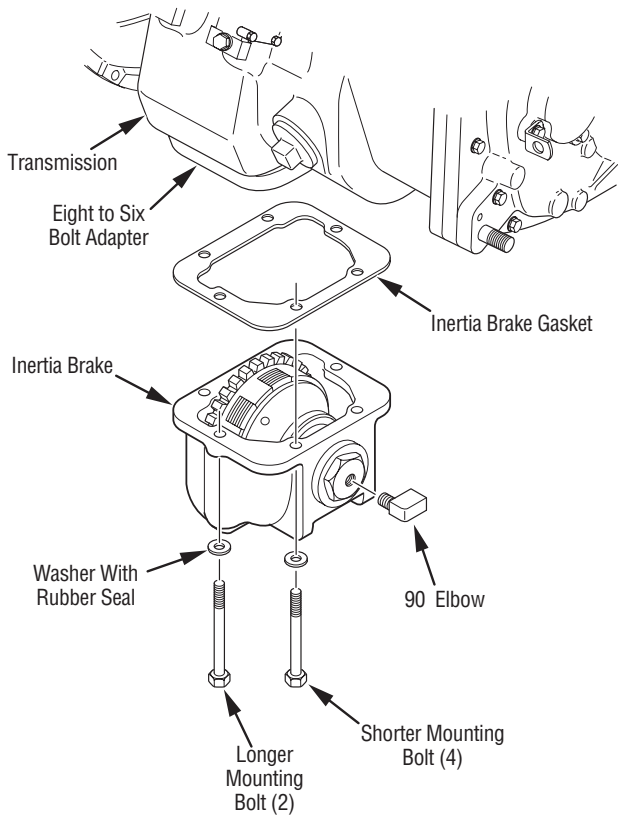

2

Reconnect Inertia  
Brake Air Line

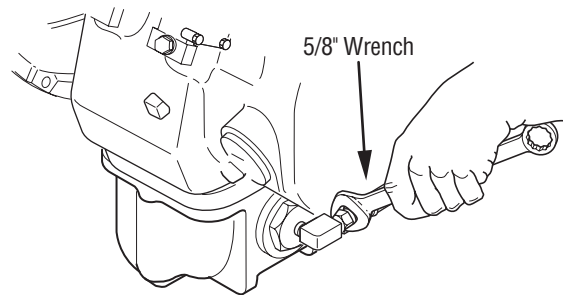

3

Fill Transmission  
with Lubricant

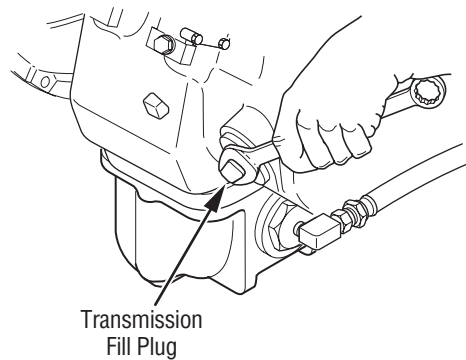

---

**Solo Heavy Duty Clutch - Install, Con't**

## Power Module - Overview

### Special Instructions

Disconnect Batteries before performing this procedure.

### Required Tools

- Basic Hand Tools.

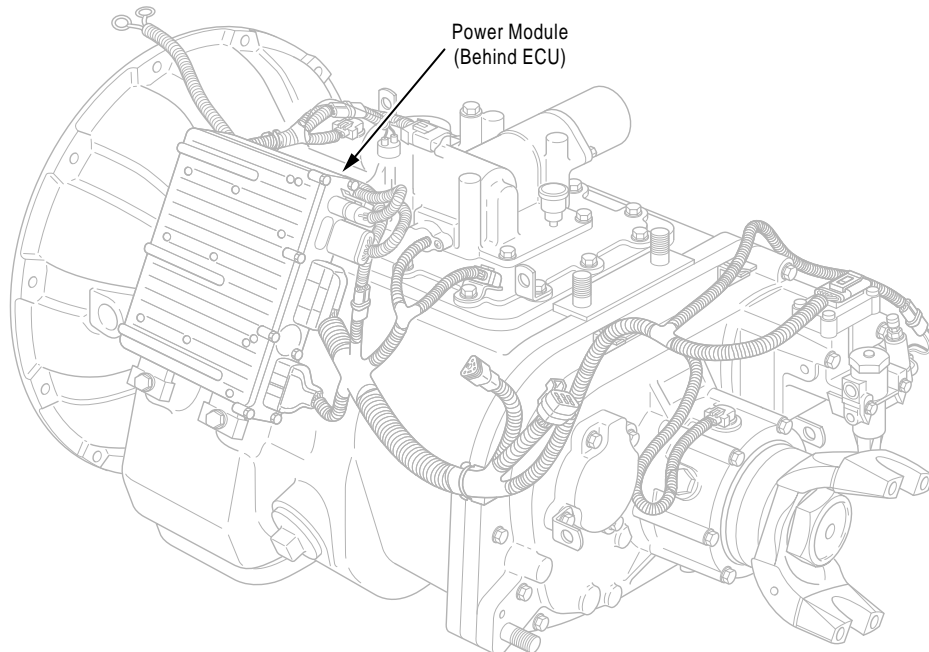

---

## **How to Remove the Power Module**

### **Procedure-**

1. Remove the two (2) 1/2" ring terminals from the starter (in the engine compartment).
2. Use a small flat-blade screwdriver to pry and disconnect the Motor Power connector from the Transmission ECU.
3. Disconnect the Logic Power connector from the Transmission Harness.
4. Using a phillips head or torx head screwdriver, remove the two (2) Power Module mounting screws.
5. Lift the Power Module assembly up and away from the transmission.

**1**  
Disconnect Ring Terminals  
at Engine Starter and Disconnect  
Power Connectors

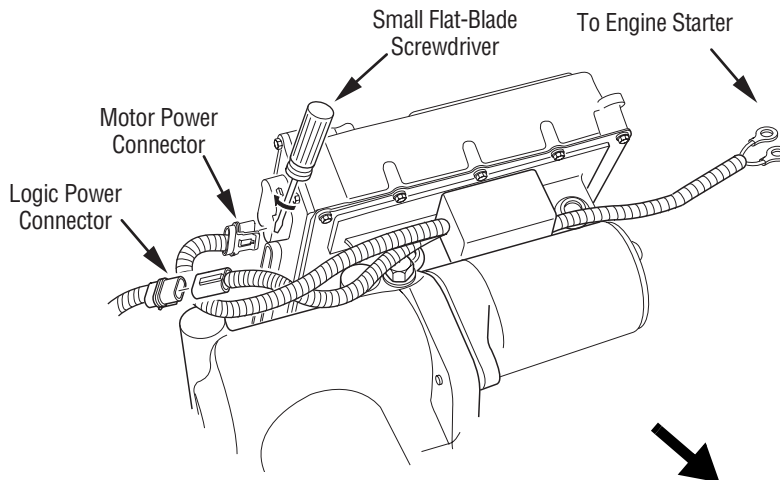

**2**  
Remove  
Mounting Screws

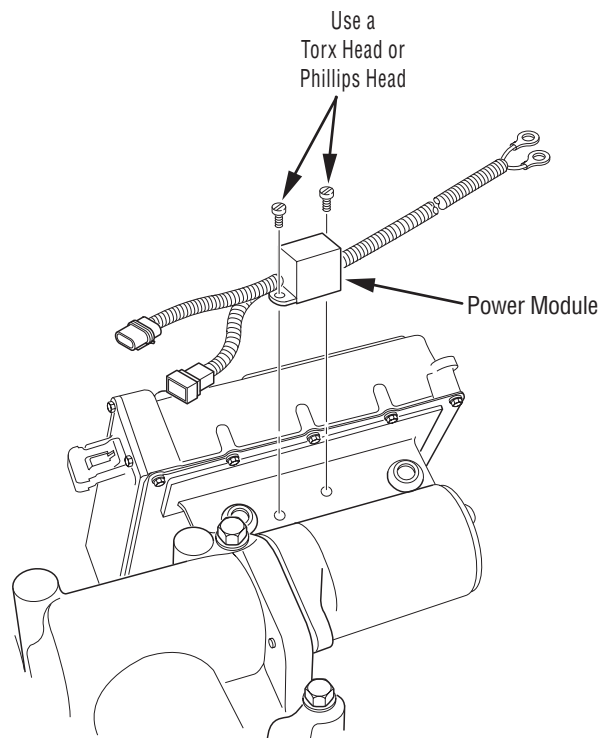

---

## How to Install the Power Module

### Procedure-

1. Position the Power Module at its mounting location.
2. Use a phillips head or torx head screwdriver to install and tighten the two (2) mounting screws.
3. Reconnect the Motor Power connector to the Transmission ECU.
4. Reconnect the Logic Power connector to the Transmission Harness.
5. Reconnect the two (2) 1/2" ring terminals to the engine starter.

**Note:** Observe proper polarity when connecting the terminals to the starter (red for positive and black for negative).

### Final Check

Verify mounting screws are properly tightened.

### Calibration

None.

**1**  
Position  
Power Module

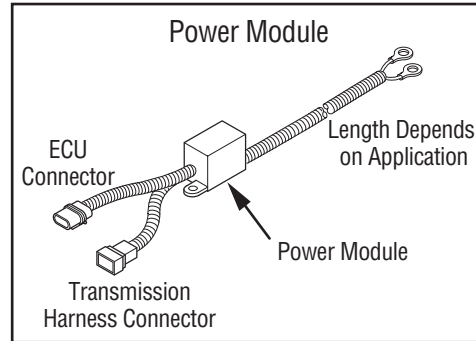
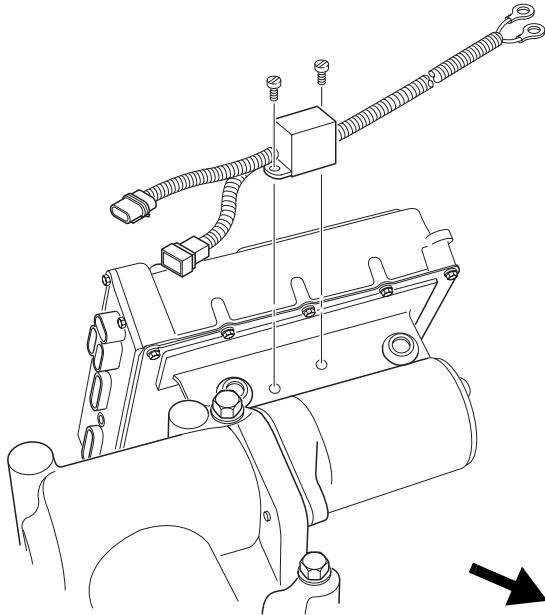

**2**  
Reconnect Power Module  
Connections and Ring  
Terminals to Starter

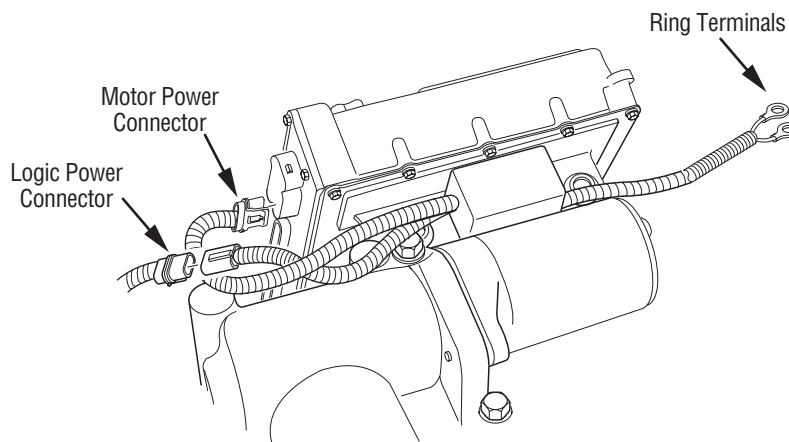



---

**Solo Heavy Duty Clutch - Install, Con't**

## Electric Shifter - Overview

### Special Instructions

Make sure the three (3) sets of detent balls and springs are installed properly in the Shift Bar Housing.

### Required Tools

- Basic Hand Tools.

### Essential Steps

**IMPORTANT:** The shifter module must be calibrated before the vehicle is placed into operation.

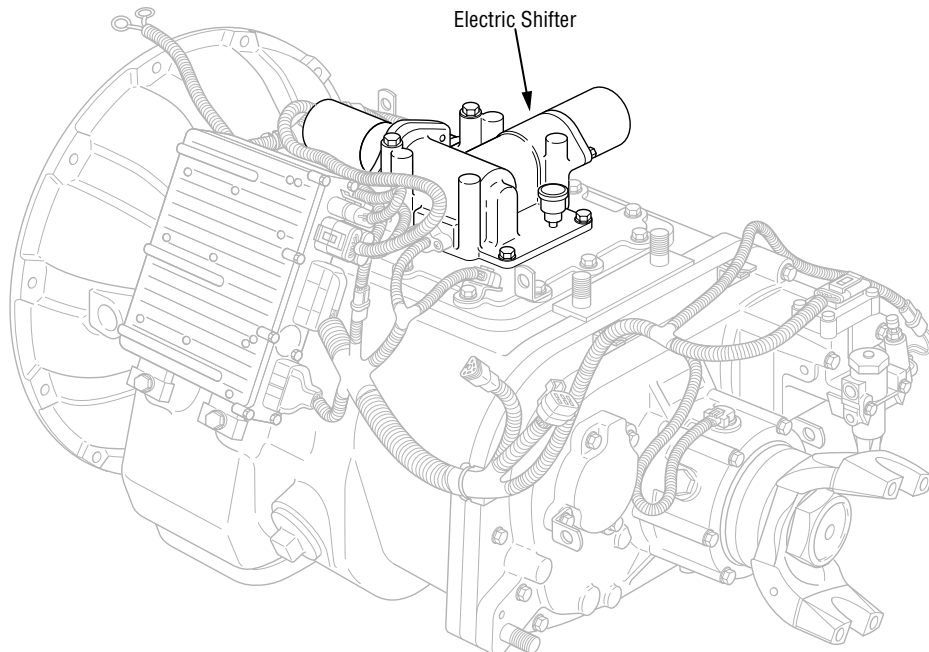

---

## **How to Remove the Electric Shifter**

### **Procedure-**

1. Remove nylon cable ties from the motor wires.
2. Disconnect the Transmission Harness from the Rail Select Sensor and the Gear Select Sensor.
3. Disconnect the Rail Select Motor from the Transmission ECU.
4. Disconnect the Gear Select Motor from the Transmission ECU.
5. Using a 9/16" wrench, remove the four (4) capscrews.
6. Remove the Electric Shifter and gasket.

**1**  
Disconnect  
Transmission Harness  
from Rail and Gear  
Select Sensors

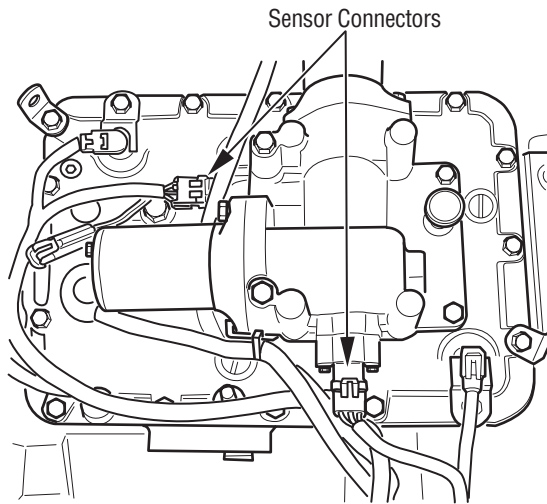

**2**  
Disconnect Rail Motor  
and Gear Motor from  
Transmission ECU

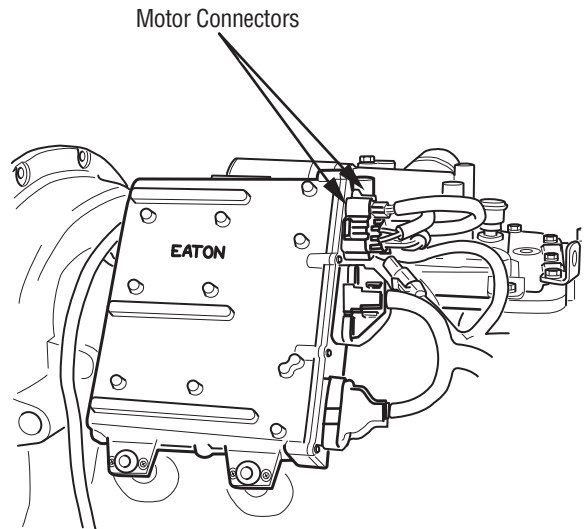

**3**  
Remove Mounting  
Capscrews

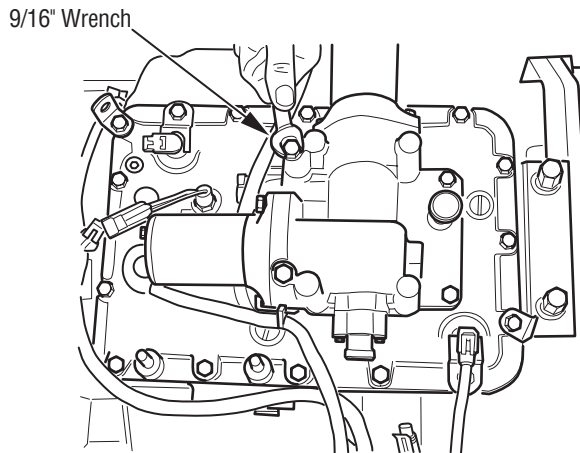

**4**  
Remove Electric  
Shifter and Gasket

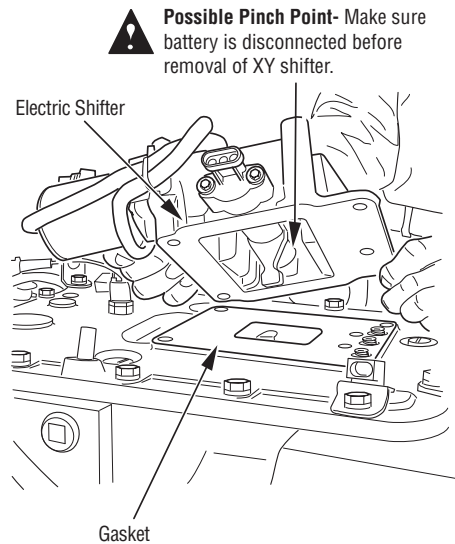

---

## How to Install the Electric Shifter

### Procedure-

1. Clean and remove old gasket material from the Shift Bar Housing.
2. Position a new gasket at the Electric Shifter mounting location.
3. Check to ensure that the shift blocks are in the Neutral position.
4. Move the shift finger to the center (NEUTRAL) location.

**Note:** If the shift finger is not properly aligned, the Electric Shifter will not fit properly at its mounting location.

5. Position the Electric Shifter on the Shift Bar Housing.
6. Using a 9/16" wrench, install and tighten the capscrews to 35-45 lbs. ft. (47.5-61.0 N•m).
7. Reconnect the Transmission Harness to the Rail Select Sensor and Gear Select Sensor.
8. Reconnect the Rail Select Motor to the Transmission ECU.
9. Reconnect the Gear Select Motor to the Transmission ECU.
10. Using nylon cable ties, secure the motor wires to the transmission in their previous position.

### Final Check

Make sure that the capscrews are tightened to specification.

Make sure all Electric Shifter connectors are securely attached.

### Calibration

To operate properly, the system must be calibrated as follows:

- a. Turn the ignition switch to ON and allow the transmission to power up.
- b. Turn the ignition switch to OFF and wait two minutes.

**IMPORTANT:** The shifter module must be calibrated before the vehicle is placed into operation.

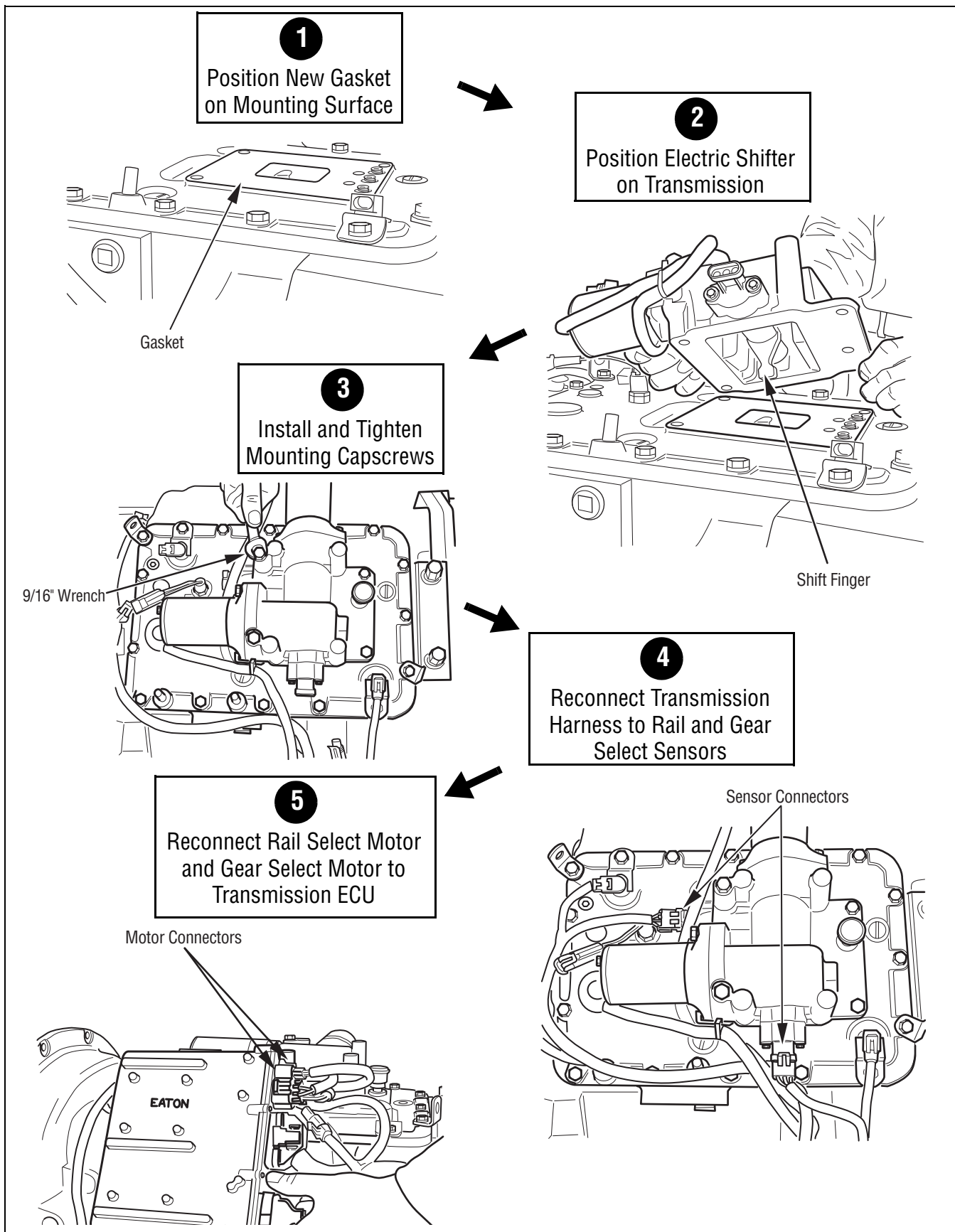

Service Procedure



## Transmission ECU - Overview

### Special Instructions

Install the Power Module on the Transmission ECU before installing the Transmission ECU.

Apply lubricant to the ECU mounting bracket locating studs on the main case top.

Make sure the three (3) 2-pin packard connectors are properly located on the Transmission ECU top.

### Required Tools

- Basic Hand Tools.

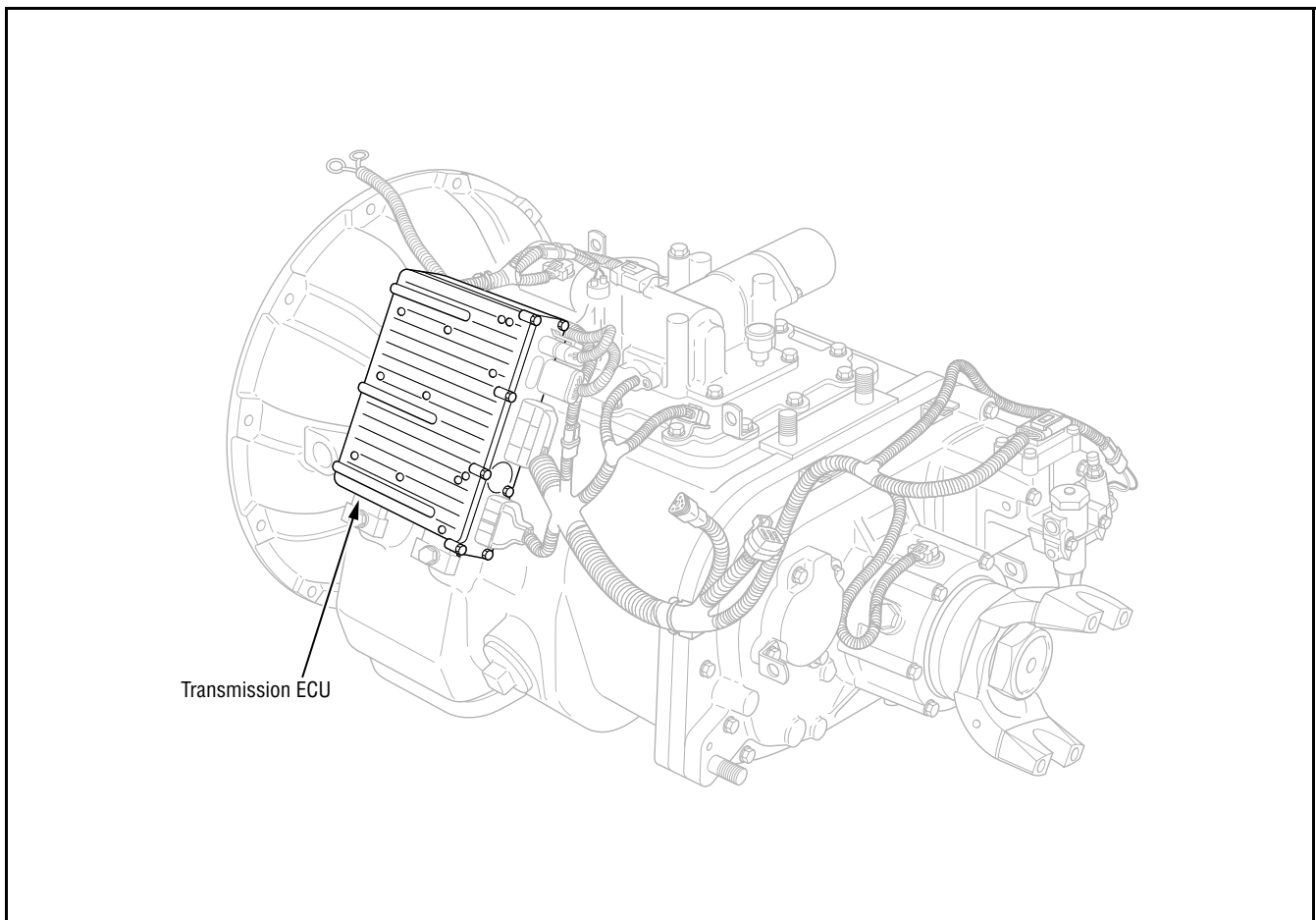



---

## How to Remove the Transmission ECU

### Procedure-

1. Disconnect the negative battery cable.
2. Remove nylon cable ties from ECU 24-way and 32-way connectors.
3. Disconnect the Gear Select Motor from the Transmission ECU.
4. Disconnect the Rail Select Motor from the Transmission ECU.
5. Use a small flat-blade screwdriver to unlock and disconnect the Motor Power connector.
6. Unlock and disconnect the Transmission ECU 32-way connector.
7. Unlock and disconnect the Transmission ECU 24-way connector.
8. Using a 1/2" wrench, remove the two (2) Transmission ECU mounting bolts.
9. Remove the Transmission ECU assembly from the locating studs.



**CAUTION:** When removing the Transmission ECU, take care not to bend the ECU locating bracket.

10. Using a phillips head or torx head screwdriver, remove the Power Module mounting screws.
11. Remove the Power Module and lay it on the transmission.

**1**  
Disconnect Five  
Transmission ECU  
connectors

Transmission ECU Connectors

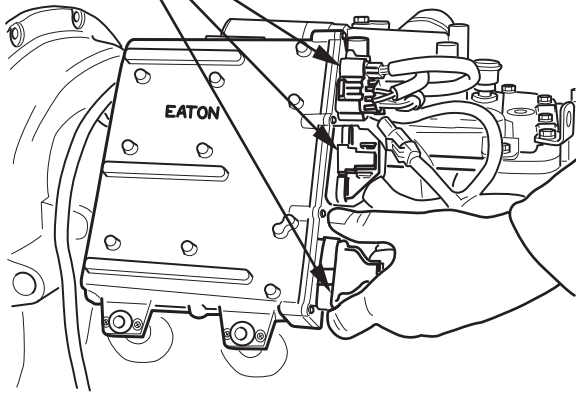

**2**  
Remove Mounting  
Capscrews

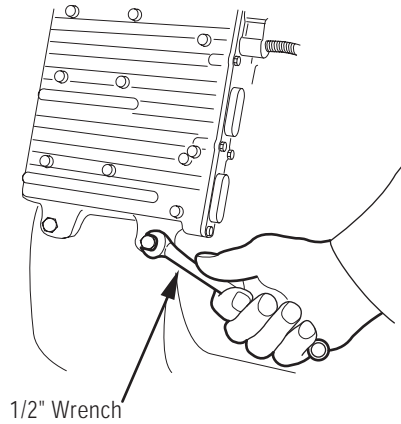

**3**  
Remove  
Transmission ECU

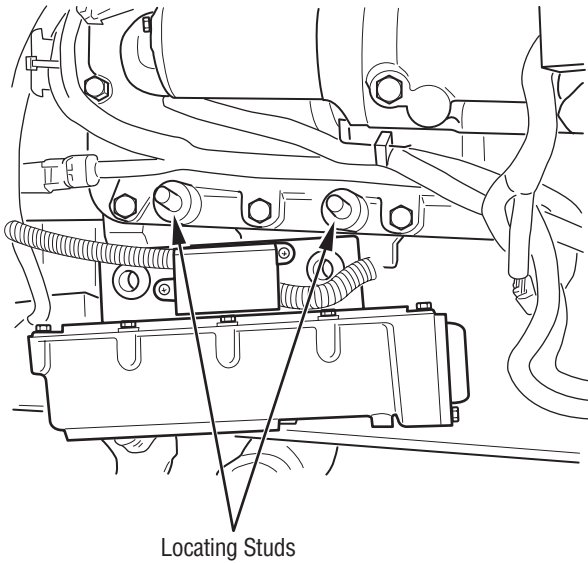

**4**  
Remove  
Power Module

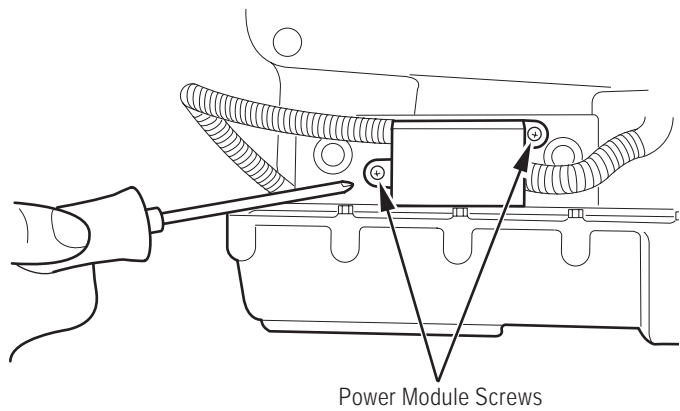

---

## How to Install the Transmission ECU

### Procedure-

1. Position the Power Module on the Transmission ECU.
2. Use a phillips head or torx head screwdriver to install and tighten the two (2) mounting screws.
3. Position the Transmission ECU on the locating studs.



**CAUTION:** When attaching the Transmission ECU, take care not to bend the ECU locating bracket.

4. Using a 1/2" wrench, install and tighten the two (2) Transmission ECU mounting bolts.
5. Reconnect the Transmission ECU 24-way connector.
6. Reconnect the Transmission ECU 32-way connector.
7. Install nylon cable ties around 24-way and 32-way connectors.
8. Reconnect the Motor Power connector.
9. Reconnect the Transmission ECU to the Rail Select Motor.
10. Reconnect the Transmission ECU to the Gear Select Motor.
11. Reconnect the negative battery cable.

### Final Check

Make sure the retaining capscrews are properly tightened.

Make sure all Transmission ECU connectors are properly connected and locked.

Make sure the shifter module harness connectors are properly connected.

### Calibration

None.

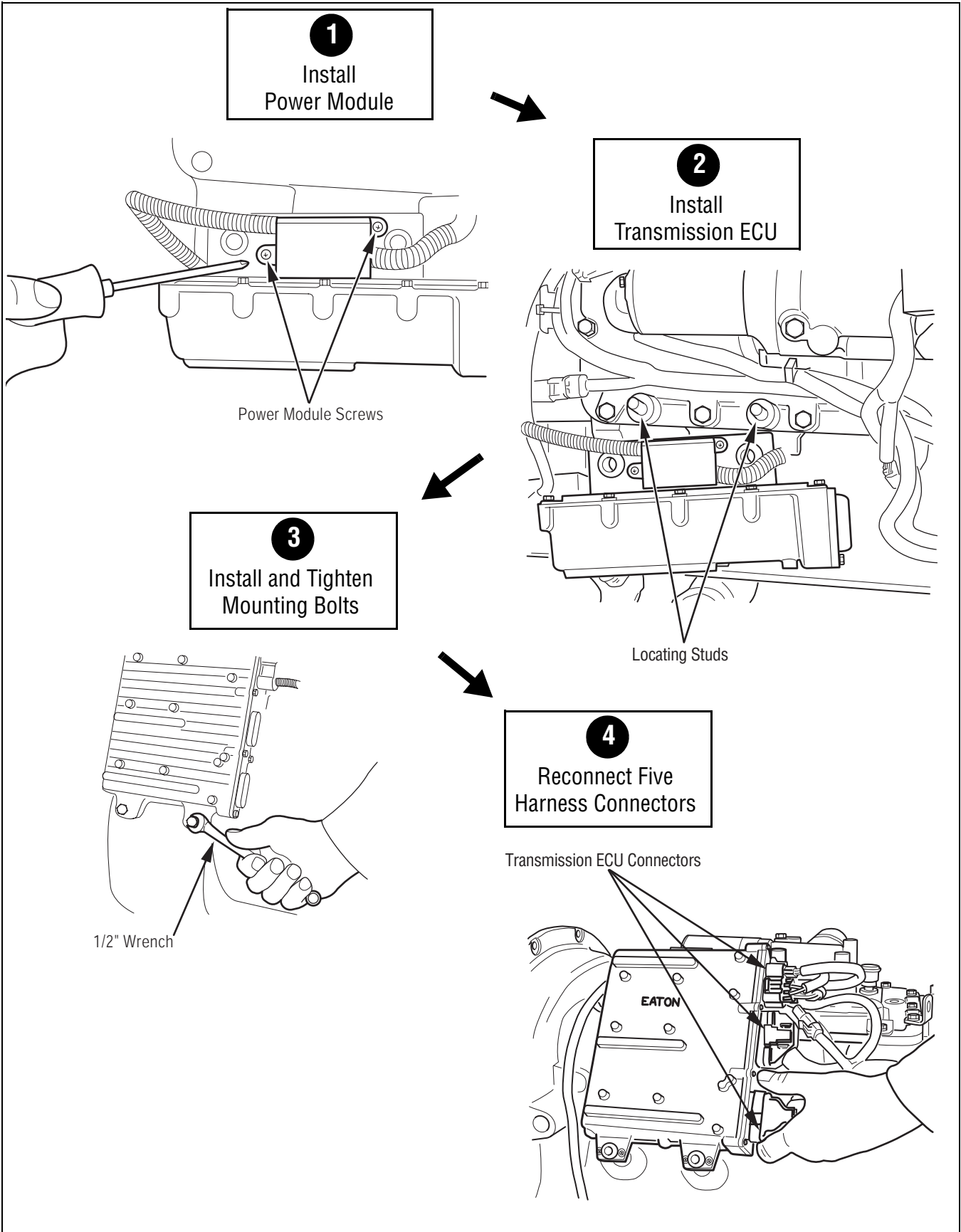

Transmission ECU Installation

---

**Solo Heavy Duty Clutch - Install, Con't**

## Transmission Harness - Overview

### Special Instructions

Make sure the three (3) two pin packard connectors are properly located on the Transmission ECU top.

### Required Tools

- Basic Hand Tools.

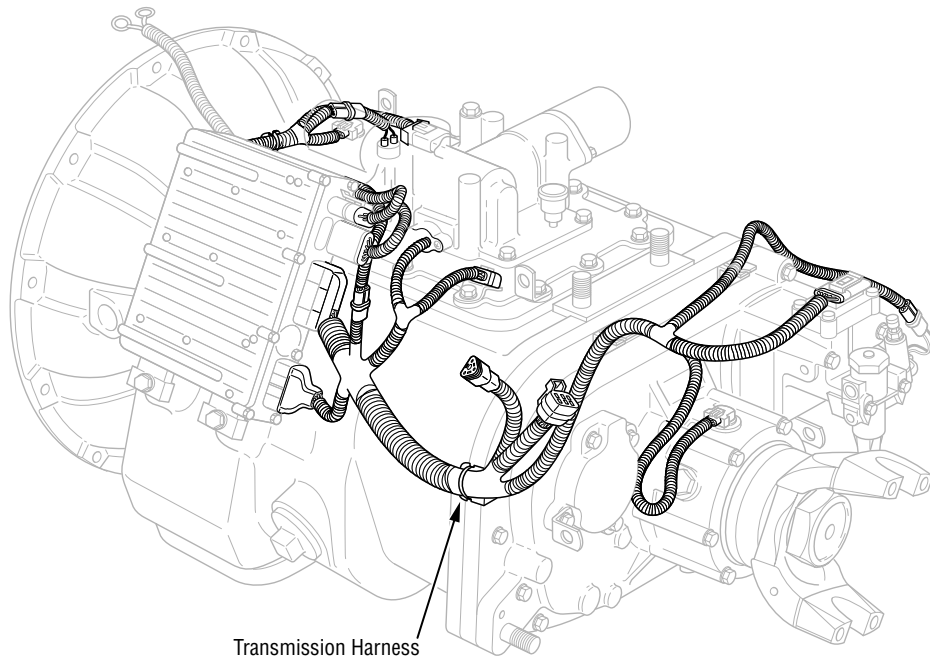

---

## How to Remove the Transmission Harness

### Procedure-

1. Remove nylon cable ties holding the harness and connectors in place.
2. Disconnect 32-way and 24-way ECU connectors from the ECU
3. Disconnect Input and Main Shaft Speed Sensors
4. Disconnect Gear Select Sensor and Rail Select Sensor
5. Disconnect Reverse Ball Switch
6. Disconnect Logic Power from the Transmission Harness
7. Disconnect Output Shaft Speed Sensor
8. Disconnect Range Solenoid Valve
9. Disconnect Transmission Interface connector
10. If required, disconnect the Splitter Solenoid and Inertia Brake Solenoid.
11. Remove the Transmission Harness.

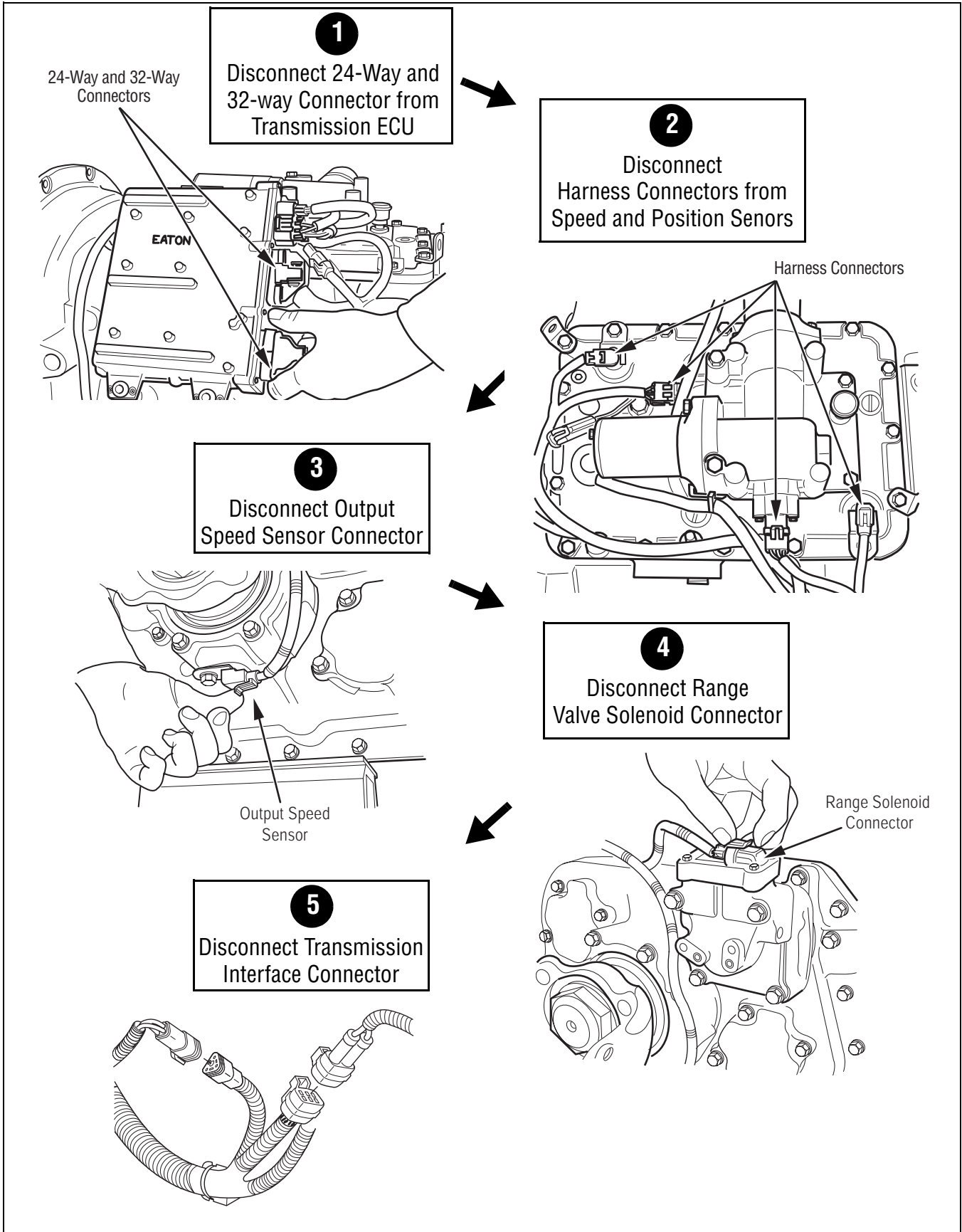



---

## How to Install the Transmission Harness

### Procedure-

1. Route the pigtail harness that comes off the 32-way connector behind the Transmission ECU and up to the top of the transmission.
2. If required, reconnect the Splitter Solenoid and Inertia Brake Solenoid.
3. Reconnect the Transmission Interface connector
4. Reconnect the Range Solenoid Valve
5. Reconnect the Output Shaft Speed Sensor
6. Reconnect the Logic Power from the Transmission Harness
7. Reconnect the Reverse Ball Switch
8. Reconnect the Gear Select Sensor and Rail Select Sensor
9. Reconnect the Input and Main Shaft Speed Sensors
10. Reconnect the 32-way and 24-way ECU connectors to the Transmission ECU
11. Replace all nylon cable ties to hold the Transmission Harness and connectors in place.

### Final Check

Double-check all connections to make sure they are secure.

### Calibration

None.

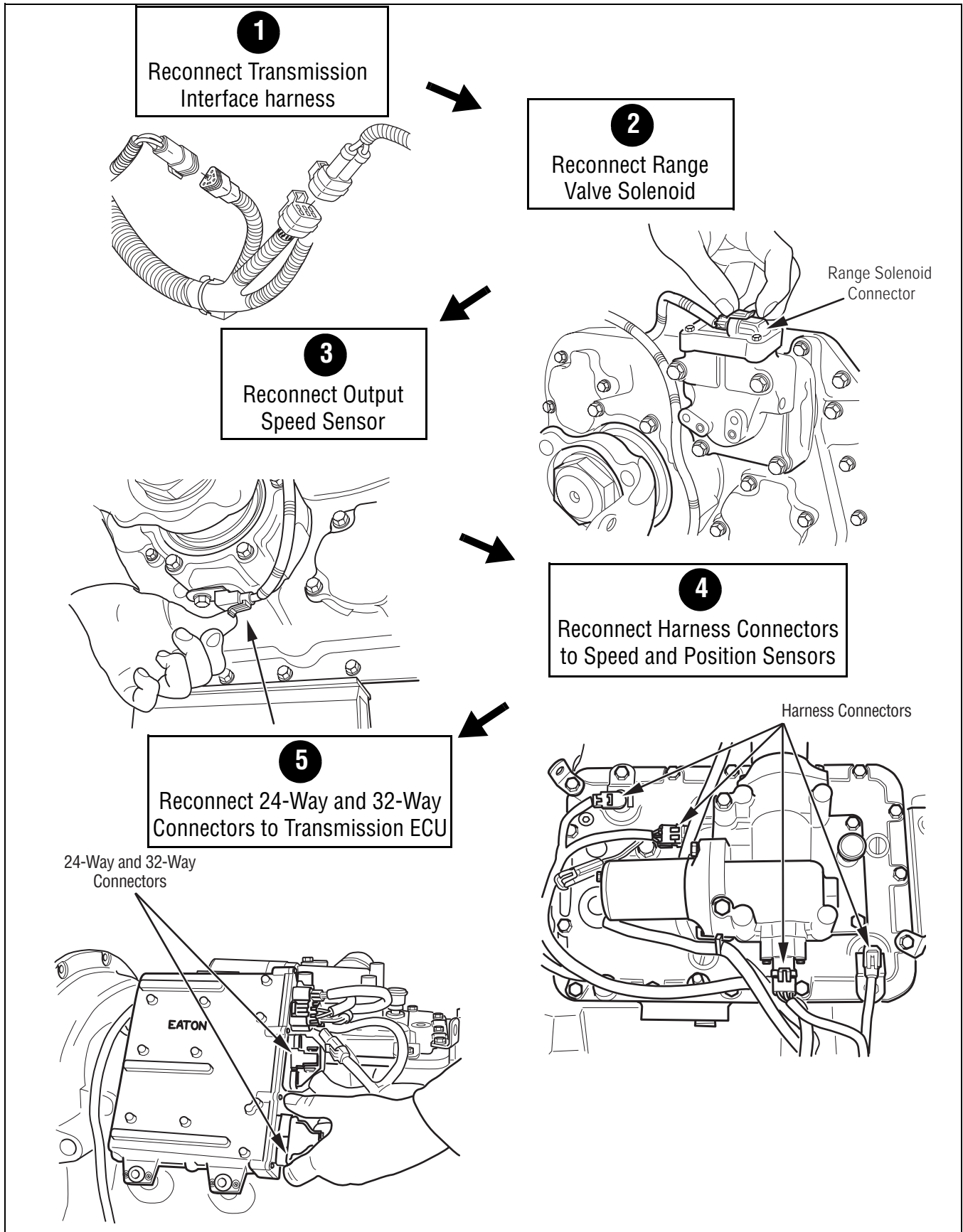

---

**Solo Heavy Duty Clutch - Install, Con't**

## Shift Lever - Overview

### Special Instructions

None.

### Required Tools

- Basic Hand Tools.

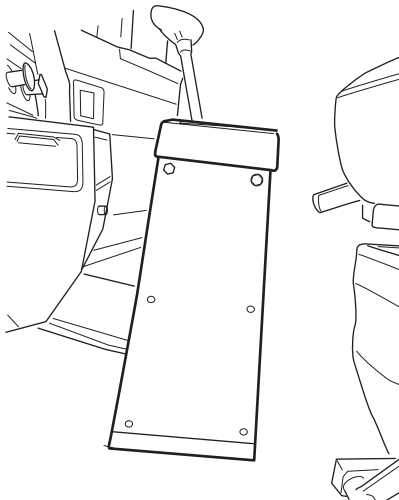

## **How to Remove the Shift Lever**

### **Procedure-**

1. Using a 7/16" wrench, remove the two (2) bolts from one side of the Shift Lever.
2. Using a 7/16" wrench, remove the other two (2) bolts from the other side of the Shift Lever.
3. Lift the Shift Lever out of the Shift Tower.
4. Disconnect the 24-way connector and the 3-way Tower Harness connectors.
5. Remove the Shift Lever.

**1**  
Remove Bolts from  
Each Side of Tower

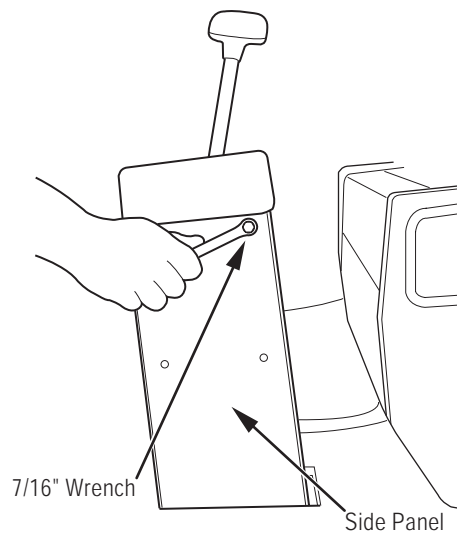
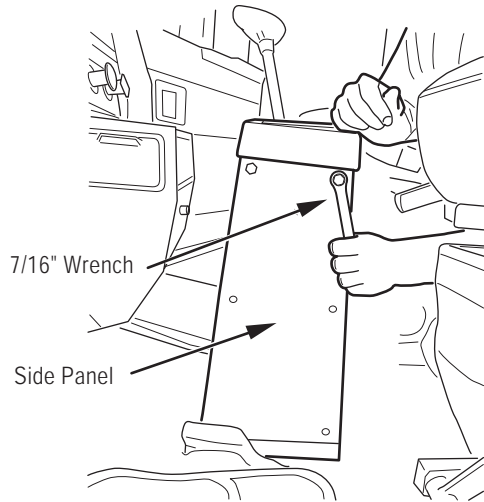

**2**  
Lift Shift Lever  
Up and Out



**2**  
Disconnect 24-Way and 3-Way  
Tower harness Connectors

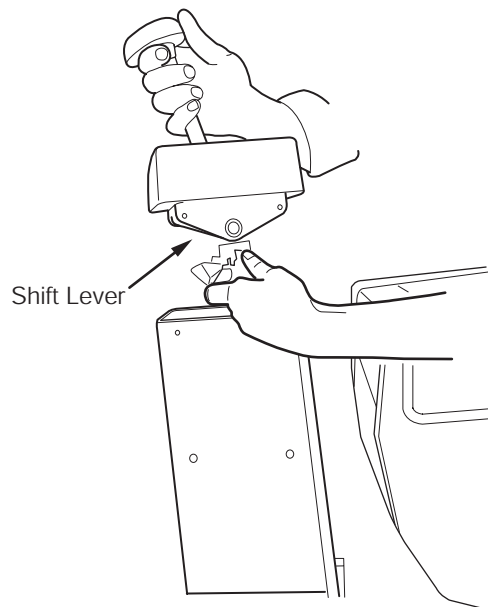

---

## How to Install the Shift Lever

### Procedure-

1. Reconnect the 24-way and 3-way Tower Harness connectors.
2. Position the Shift Lever assembly on its mounting surface.
3. Apply blue loctite #242 to the four (4) mounting bolts.
4. Using a 7/16" wrench, install and tighten the bolts to 6-8 lbs. ft. (8.1-10.8 N•m).

### Final Check

Make sure the mounting bolts are properly torqued.

### Calibration

None.

**1**  
Reconnect 24-Way and 3-Way  
Harness Connectors

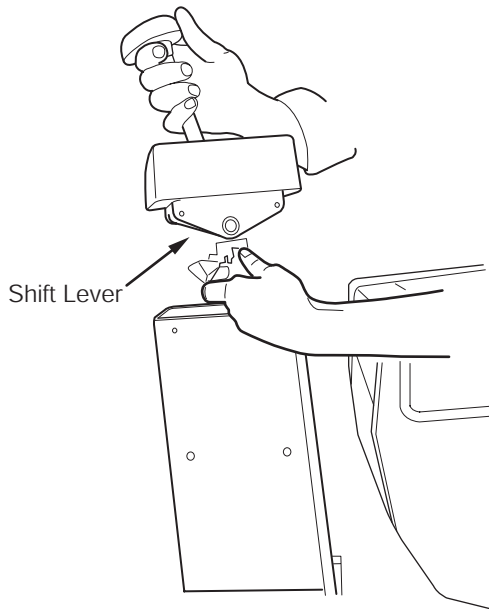

**2**  
Install Shift Lever



**3**  
Install Bolts on  
Each Side of Tower

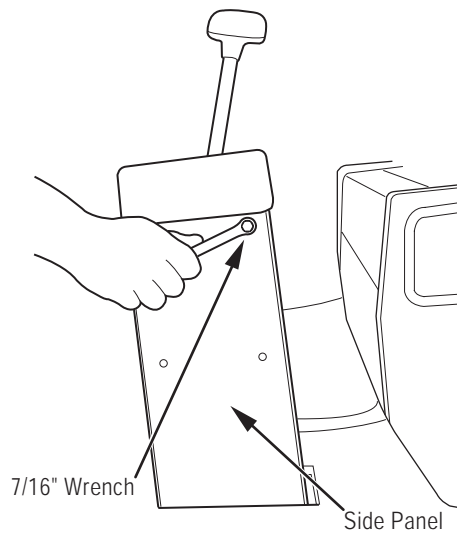
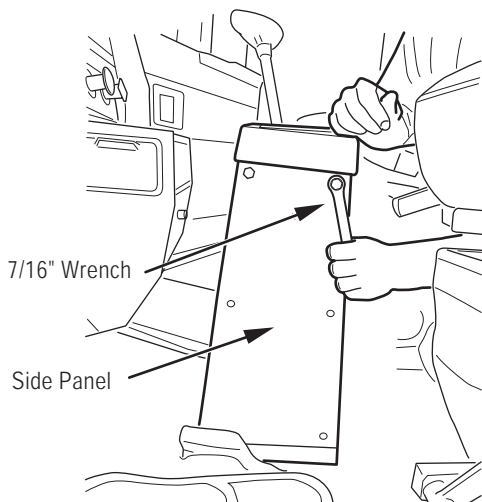



---

**Solo Heavy Duty Clutch - Install, Con't**

## Power Relay - Overview

### Special Instructions

If the Shift Tower is supplied by Eaton, the Power Relay is located inside the cab in the Shift Tower.

### Required Tools

- Basic Hand Tools.

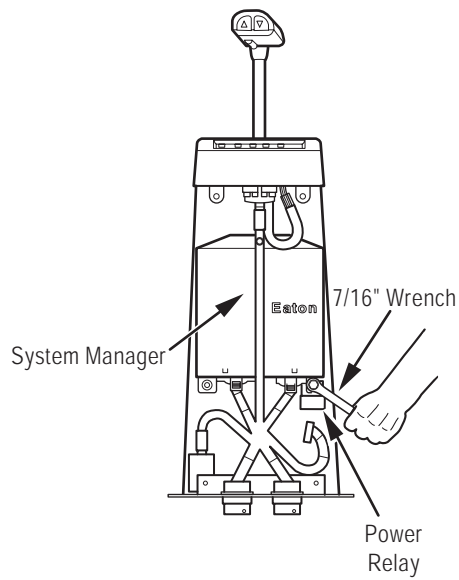

---

## **How to Remove the Power Relay**

### **Procedure-**

1. Using a 7/16" wrench, remove the two (2) Shift Lever mounting bolts from the driver's side of the Shift Tower.
2. Using a phillips-head screwdriver, remove the four (4) screws that secure the driver-side Shift Tower side panel.
3. Remove the Shift Tower side panel.
4. Disconnect the Tower Harness from the Power Relay.
5. Using a 7/16" wrench, remove the lower-right System Manager retaining nut that secures the Power Relay.
6. Remove the Power Relay.

**1**  
Remove Bolts and  
Screws from Side Panel

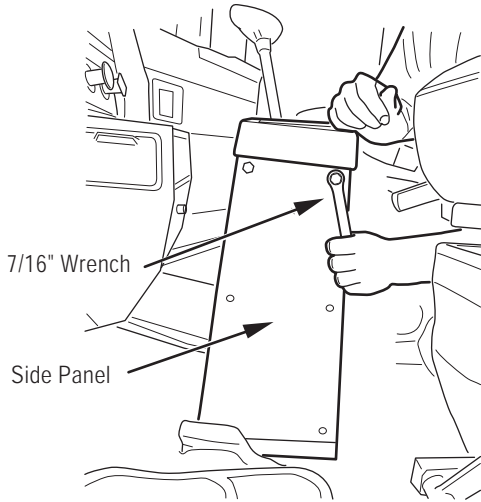

**2**  
Remove Shift Tower  
Side Panel

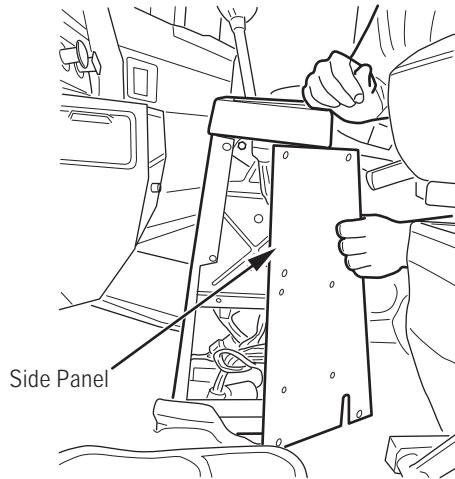

**3**  
Disconnect  
Tower Harness

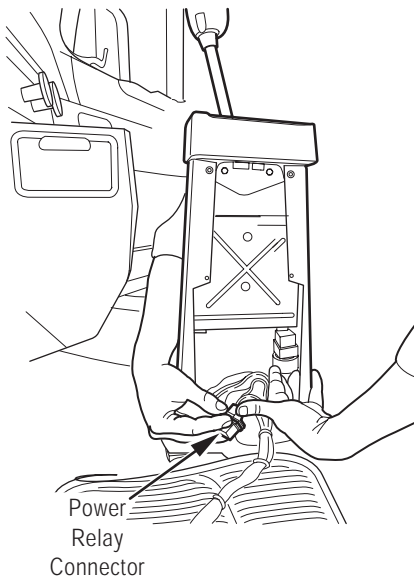

**4**  
Remove Retaining Nut  
and Power Relay

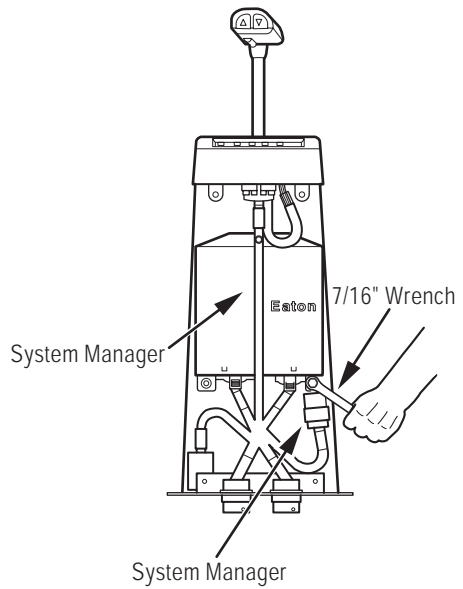

---

## How to Install the Power Relay

### Procedure-

1. Position the Power Relay over its mounting location.
2. Using a 7/16" wrench, install and tighten the System Manager mounting bolt to 10-12 lbs. in. (1.1-1.4 N•m).
3. Reconnect the Tower Harness to the Power Relay.
4. Position the Shift Tower side panel over its mounting location.
5. Using a phillips-head screwdriver, install and tighten the four (4) screws that secure the driver-side Shift Tower side panel.
6. Apply loctite #242 compound to the two (2) mounting bolts.
7. Using a 7/16" wrench, install and tighten the two (2) Shift Lever mounting bolts to 6-8 lbs. ft. (8.1-10.8 N•m).

### Final Check

Make sure the side panel mounting bolts and screws are tightened to specification.

### Calibration

None.

**1**  
Install Power Relay  
and Retaining Nut

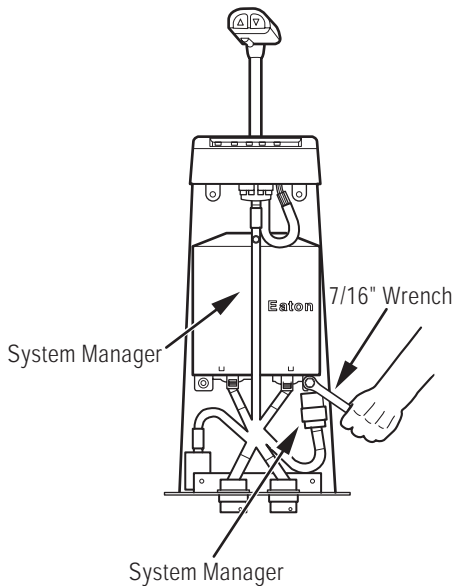

**2**  
Reconnect  
Tower Harness

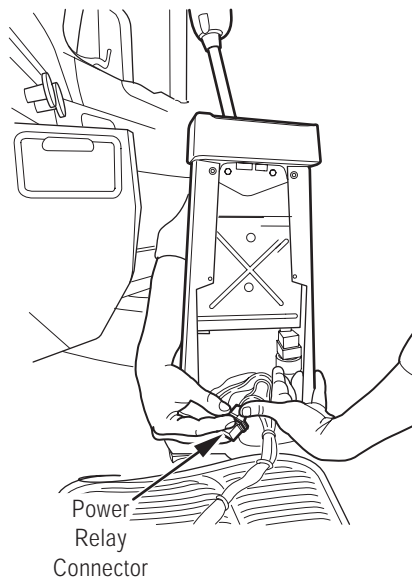

**3**  
Install Shift Tower  
Side Panel

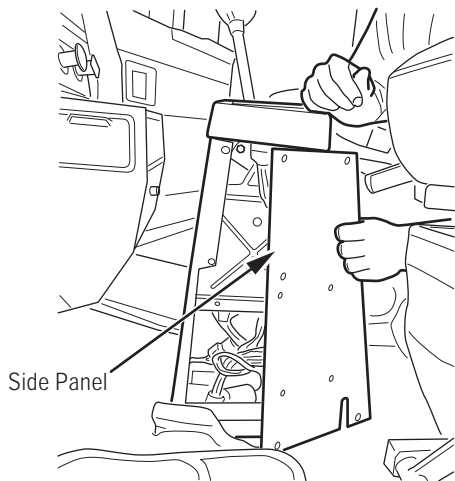

**4**  
Install and Tighten  
Bolts and Screws

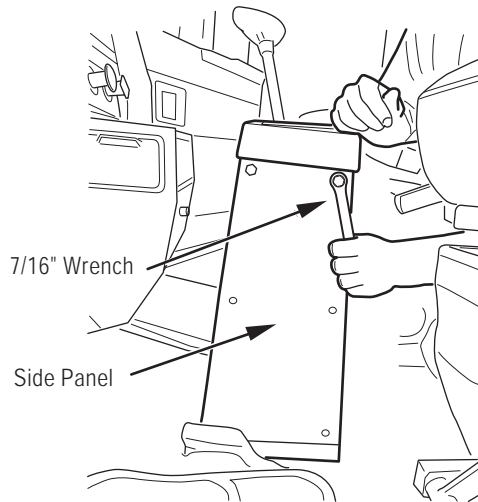

Service Procedure

---

**Solo Heavy Duty Clutch - Install, Con't**

## System Manager - Overview

### Special Instructions

None.

### Required Tools

- Basic Hand Tools.

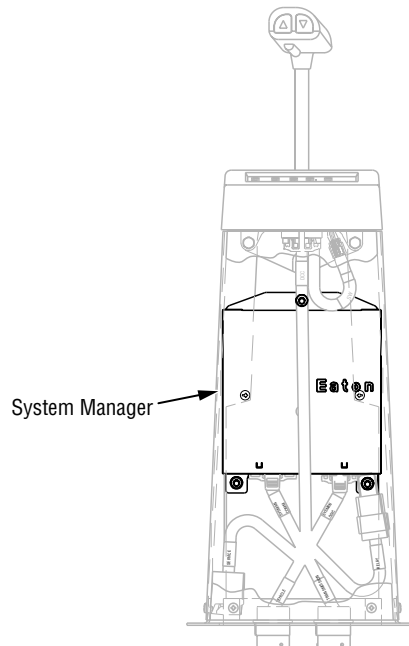



---

## How to Remove the System Manager

### Procedure-

1. Using a 7/16" wrench, remove the two (2) Shift Lever mounting bolts from the driver's side of the Shift Tower.
2. Using a phillips-head screwdriver, remove the four (4) screws that secure the driver-side Shift Tower side panel.
3. Remove the Shift Tower side panel.
4. Disconnect the System Manager 32-way connector.
5. Disconnect the System Manager 24-way connector.
6. Using a 7/16" wrench, remove the three (3) System Manager mounting nuts.
7. Temporarily disconnect and remove the Power Relay and set it aside.
8. Slide the System Manager down and out of the Shift Tower.

**1**  
Remove Bolts and  
Screws from Side Panel

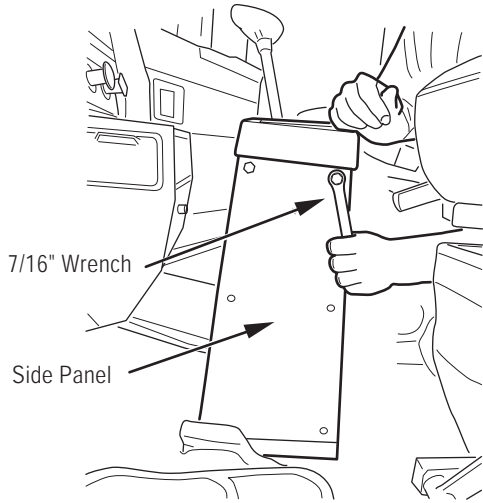

**2**  
Remove Shift Tower  
Side Panel

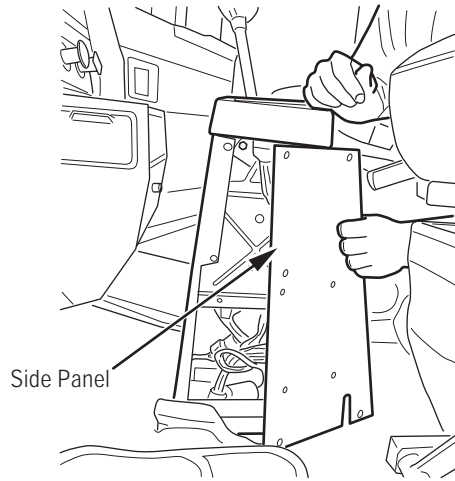

**3**  
Disconnect 32-Way and  
24-Way Connectors

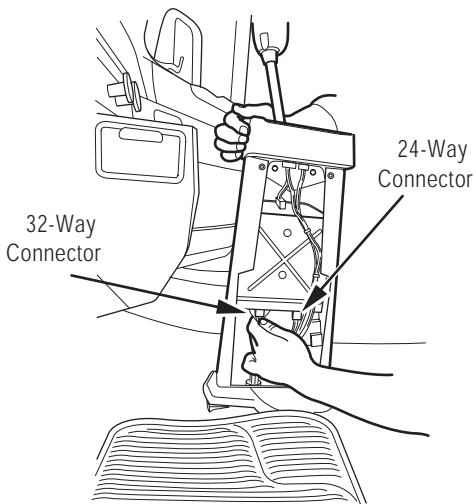

**4**  
Remove 3 Nuts Holding System  
Manager, Remove and Set Aside  
Power Relay, Remove System Manager

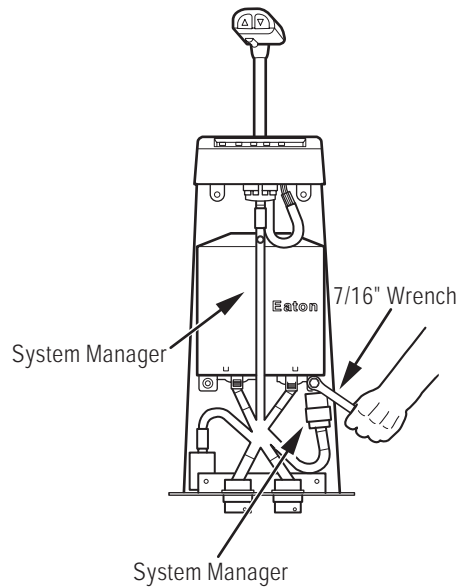

---

## How to Install the System Manager

### Procedure-

1. Slide the System Manager into the Shift Tower and position it on the three (3) mounting studs.
2. Install and finger tighten two (2) of the System Manager mounting nuts.
3. Reinstall the Power Relay in its original location and finger tighten the System Manager/Power Relay mounting nut.
4. Using a 7/16" wrench, tighten the three (3) System Manager mounting nuts to 10-12 lbs. in. (1.1-1.4 N•m).
5. Reconnect the Tower Harness to the Power Relay.
6. Reconnect the System Manager 32-way connector.
7. Reconnect the System Manager 24-way connector.
8. Position the Shift Tower side panel over its mounting location.
9. Using a phillips-head screwdriver, install and tighten the four (4) screws that secure the driver-side Shift Tower side panel.
10. Apply loctite #242 compound to the two (2) mounting bolts.
11. Using a 7/16" wrench, install and tighten the two (2) Shift Lever mounting bolts to 6-8 lbs. ft. (8.1-10.8 N•m).

### Final Check

Make sure the connectors are secure before installing the side panel.

Make sure the side panel mounting bolts and screws are tightened to specification.

### Calibration

None.

**1**  
Install System Manager  
and Power Relay

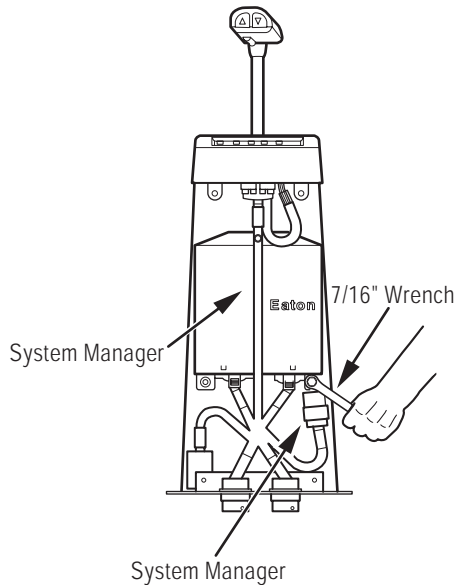

**2**  
Reconnect Tower Harness to Power  
Relay, 24-Way Connector and  
32-Way Connector

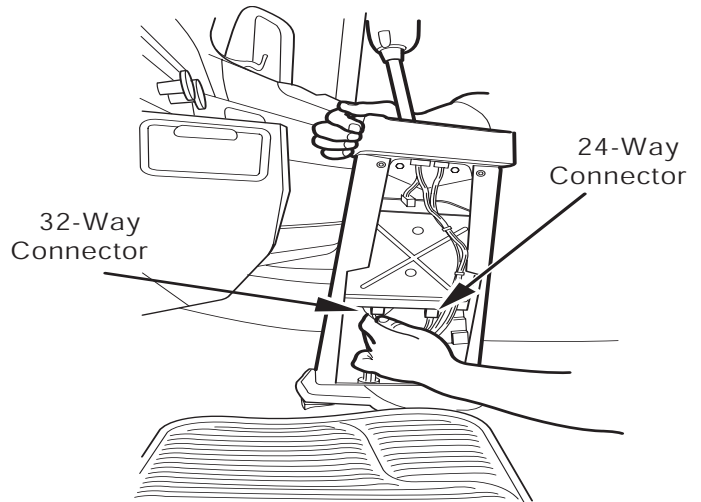

**3**  
Install Shift Tower  
Side Panel

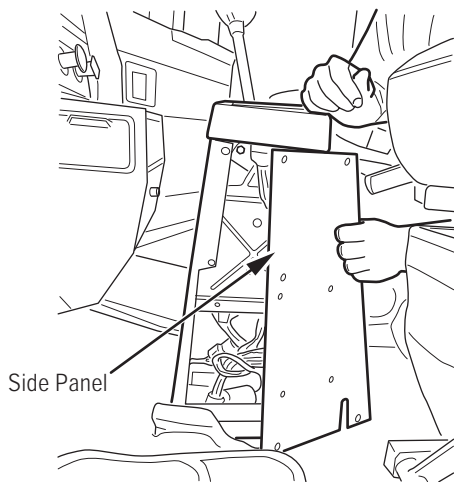

**3**  
Tighten Bolts and  
Screws on Side Panel

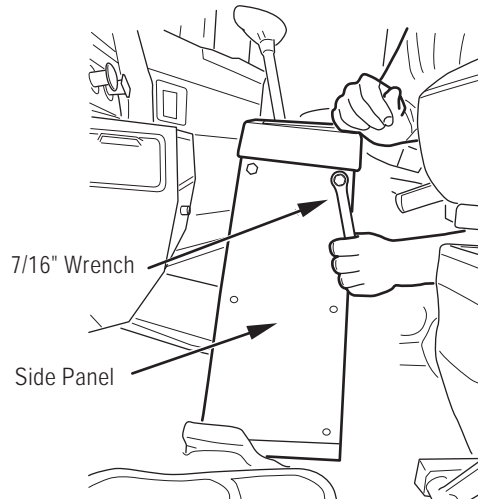

Service Procedure

---

**Solo Heavy Duty Clutch - Install, Con't**

## Tower Harness - Overview

### Special Instructions

None.

### Required Tools

- Basic Hand Tools.

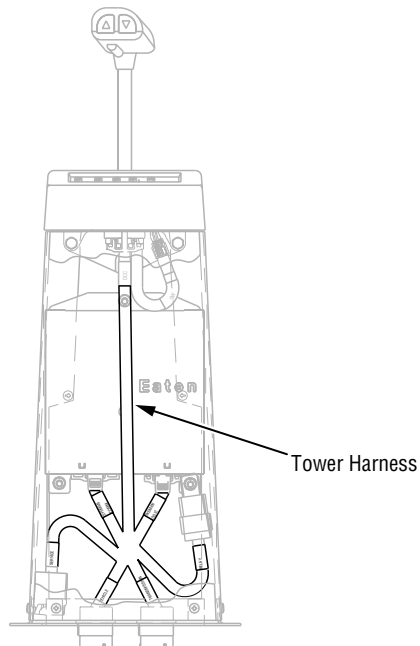

---

## How to Remove the Tower Harness

### Procedure-

1. Using a 7/16" wrench, remove the two (2) Shift Lever mounting bolts from the driver's side of the Shift Tower.
2. Using a phillips-head screwdriver, remove the four (4) screws that secure the driver-side Shift Tower side panel.
3. Remove the Shift Tower side panel.
4. Disconnect the 24-way connector and 3-way connector from the Shift Lever.
5. Disconnect the System Manager 32-way connector.
6. Disconnect the System Manager 24-way connector.
7. Disconnect the Tower Harness from the Power Relay.
8. Disconnect the two (2) Tower Harness connectors from the Tower Harness sockets beneath the vehicle floor-board.
9. Using a 1-11/16" wrench, remove the two (2) washers and jam nuts from the Tower Harness sockets.

**Note:** The jam nuts are located under the vehicle floor-board directly above the transmission.

10. Remove the Tower Harness from the Shift Tower.

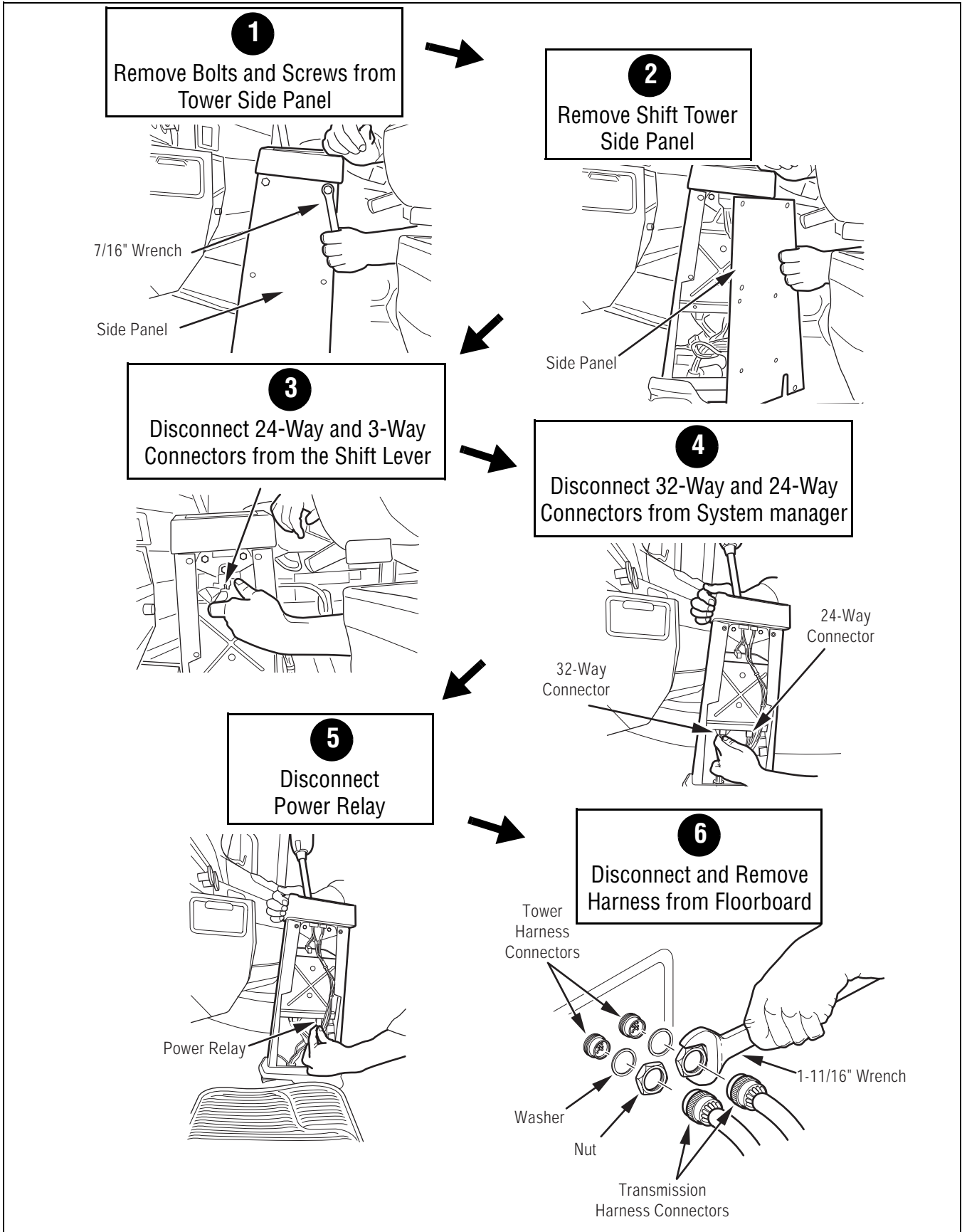

Tower Harness Removal



---

## How to Install the Tower Harness

### Procedure-

1. Slide the two (2) large Tower Harness sockets down through the vehicle floorboard.  
  
**Note:** The connectors are individually keyed to match the appropriate Tower Harness sockets.
2. Using a 1-11/16" socket wrench, install and tighten the washers and jam nuts to 260-280 lbs. in. (29.4-31.6 N•m).
3. Reconnect the two (2) Tower Harness connectors to the sockets underneath the vehicle floorboard.
4. Route the new Tower Harness from the floorboard, up into the Shift Tower assembly.
5. Reconnect the Tower Harness to the Power Relay.
6. Reconnect the System Manager 32-way connector.
7. Reconnect the System Manager 24-way connector.
8. Reconnect the 24-way connector and 3-way connector to the Shift Lever.
9. Position the Shift Tower side panel over its mounting location.
10. Using a phillips-head screwdriver, install and tighten the four (4) screws that secure the driver-side Shift Tower side panel.
11. Apply loctite #242 compound to the two (2) mounting bolts.
12. Using a 7/16" wrench, install and tighten the two (2) Shift Lever mounting bolts to 6-8 lbs. ft. (8.1-10.8 N•m).

### Final Check

Make sure the connectors are secure before installing the side panel.

Make sure the side panel mounting bolts and screws are tightened to specification.

### Calibration

None.

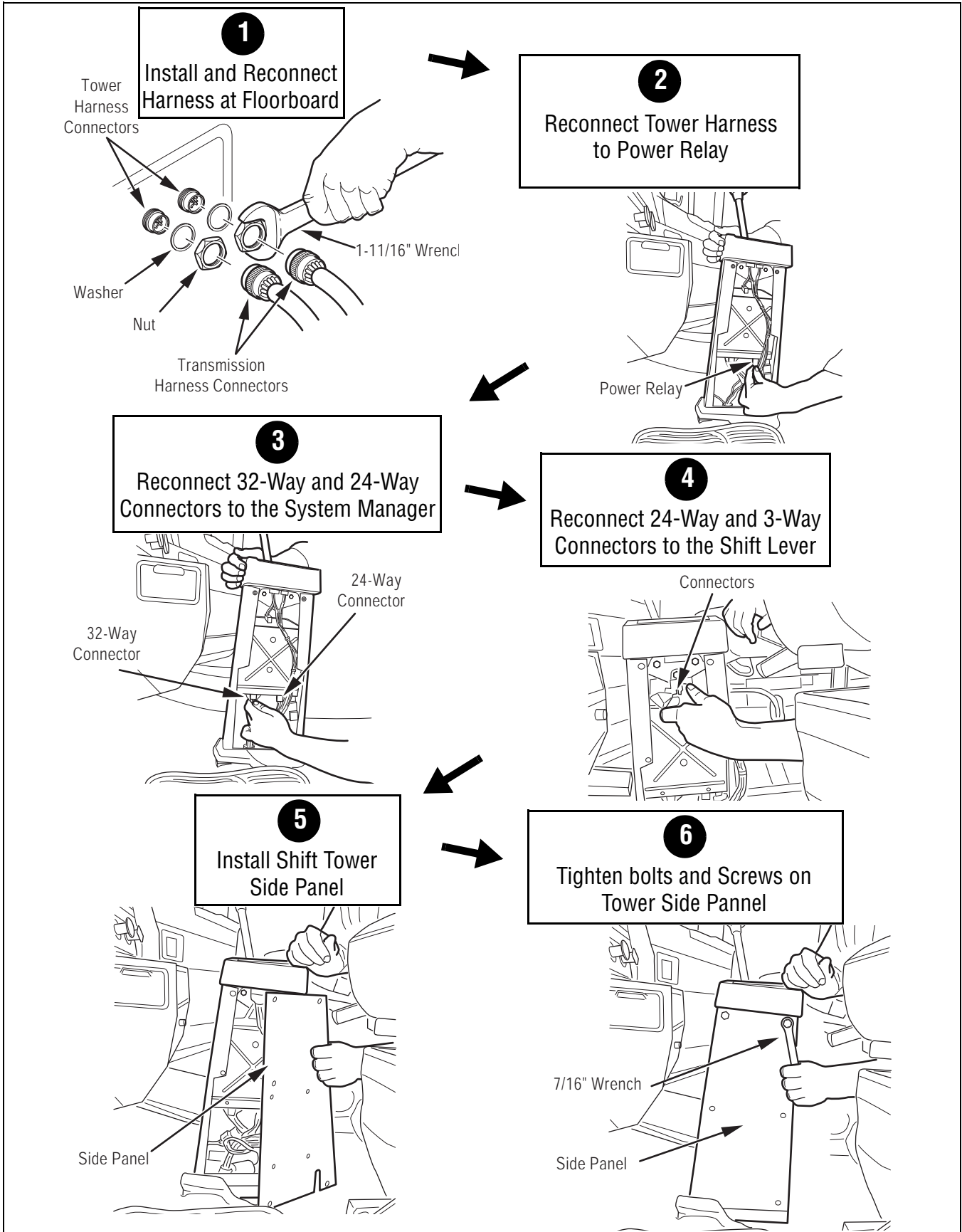

Service Procedure

---

**Solo Heavy Duty Clutch - Install, Con't**

## Gear Display - Overview

### Special Instructions

The exact location varies depending on vehicle manufacturer.

### Required Tools

- Basic Hand Tools.

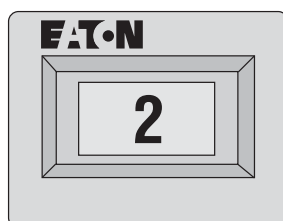

## **How to Remove the Gear Display**

### **Procedure-**

1. Follow the recommended OEM procedure to remove the dash panel that holds the Gear Display unit.
2. Disconnect the Dash Harness from the Gear Display unit.
3. Use a small flat bladed screwdriver to depress the tabs that hold the Gear Display in the dash. Then remove the Gear Display from the dash panel.

**1**  
Remove Dash Panel  
and Disconnect Harness  
from Gear Display

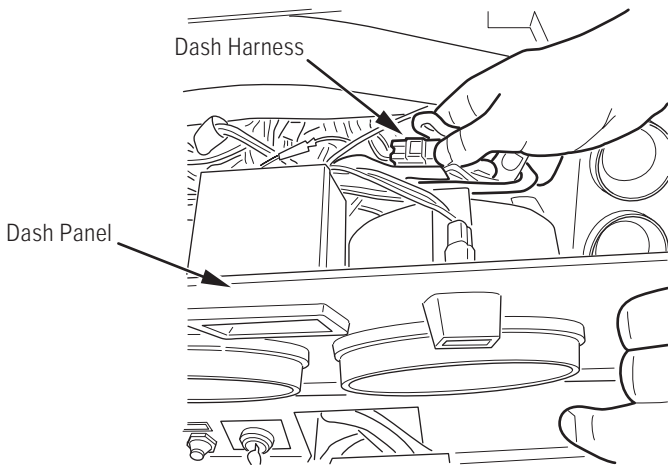

**2**  
Depress Tabs and  
Remove Gear Display

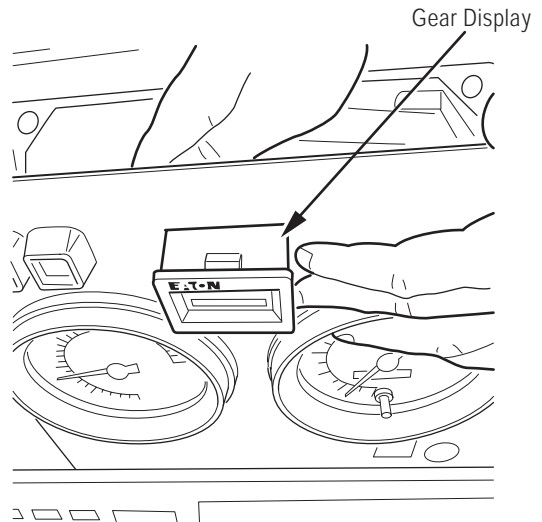

---

## How to Install the Gear Display

### Procedure-

1. Install the Gear Display unit in the dash panel.
2. Reconnect the Dash Harness to the Gear Display unit.
3. Follow the recommended OEM procedure to install the dash panel that holds the Gear Display unit.

### Final Check

Make sure the OEM Dash Harness is properly connected.

Make sure the dash panel is properly installed.

### Calibration

None.

**1**  
Install Gear  
Display

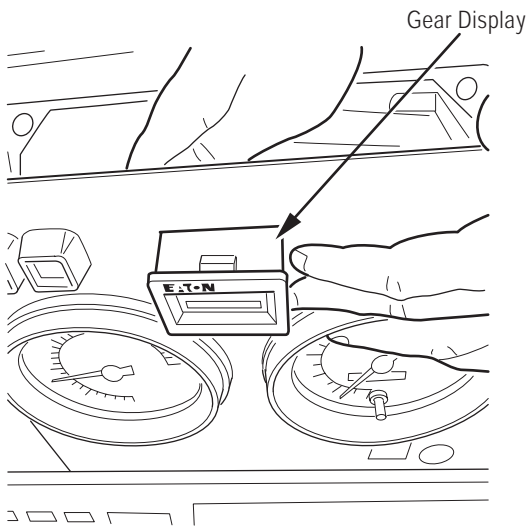

**2**  
Reconnect Dash  
Harness and  
Install Dash  
Panel

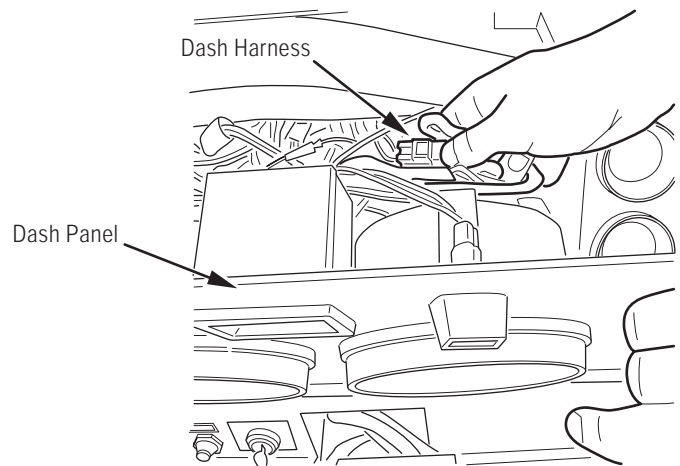



Copyright Eaton Corporation, 2012. Eaton hereby grant their customers, vendors, or distributors permission to freely copy, reproduce and/or distribute this document in printed format. It may be copied only in its entirety without any changes or modifications. THIS INFORMATION IS NOT INTENDED FOR SALE OR RESALE, AND THIS NOTICE MUST REMAIN ON ALL COPIES.

**Note:** Features and specifications listed in this document are subject to change without notice and represent the maximum capabilities of the software and products with all options installed. Although every attempt has been made to ensure the accuracy of information contained within, Eaton makes no representation about the completeness, correctness or accuracy and assumes no responsibility for any errors or omissions. Features and functionality may vary depending on selected options.

**For spec'ing or service assistance, call 1-800-826-HELP (4357) or visit [www.eaton.com/roadranger](http://www.eaton.com/roadranger). In Mexico, call 001-800-826-4357.**

Roadranger: Eaton and trusted partners providing the best products and services in the industry, ensuring more time on the road.

**Eaton Corporation**

Vehicle Group  
P.O. Box 4013  
Kalamazoo, MI 49003 USA  
800-826-HELP (4357)  
[www.eaton.com/roadranger](http://www.eaton.com/roadranger)

Printed in USA

For parts or service call us  
Pro Gear & Transmission, Inc.



**1 (877) 776-4600**

**(407) 872-1901**

**parts@eprogear.com**

**906 W. Gore St.**

**Orlando, FL 32805**

