

Fuller Heavy Duty Transmissions TRSM0300

October 2007

RTO-11607L
RTO-11607L
RTO-11607LL
RTO-11607LL
RTOF-11607L
RTOF-11607LL



Powering Business Worldwide

BACKED BY

Roadranger

SUPPORT

For parts or service call us
Pro Gear & Transmission, Inc.



1 (877) 776-4600

(407) 872-1901

parts@eprogear.com

906 W. Gore St.

Orlando, FL 32805



TABLE OF CONTENTS

FOREWORD

MODEL DESIGNATIONS AND SPECIFICATIONS

LUBRICATION

OPERATION

(L) Models

(LL) Models

POWER FLOW

TIMING

TORQUE RECOMMENDATIONS

TOOL REFERENCE

PREVENTIVE MAINTENANCE

PRECAUTIONS

DISASSEMBLY

INSPECTION

REASSEMBLY

CHANGING INPUT SHAFT

AIR SYSTEM

RANGE SHIFT AIR SYSTEM: ALL MODELS

DEEP REDUCTION AIR SYSTEM: (LL) Models

AIR SYSTEM SCHEMATICS

DISASSEMBLY AND REASSEMBLY - SHIFTING CONTROLS

AIR SYSTEM

GEAR SHIFT LEVER HOUSING ASSEMBLY

SHIFT BAR HOUSING ASSEMBLY

REMOVAL - COMPANION FLANGE, AUXILIARY SECTION AND CLUTCH HOUSING

DISASSEMBLY - AUXILIARY SECTION (L) Models

REASSEMBLY - AUXILIARY SECTION (L) Models

DISASSEMBLY - AUXILIARY SECTION (LL) Models

REASSEMBLY - AUXILIARY SECTION (LL) Models

DISASSEMBLY - FRONT SECTION

REASSEMBLY - FRONT SECTION

INSTALLATION - COMPANION FLANGE, AUXILIARY SECTION

AND CLUTCH HOUSING

INSTALLATION - SHIFTING CONTROLS

SHIFT BAR HOUSING ASSEMBLY

GEAR SHIFT LEVER HOUSING ASSEMBLY

AIR SYSTEM

FOREWORD

This manual is designed to provide detailed information necessary to service and repair the Fuller Transmissions listed on the cover.

As outlined in the Table of Contents, the manual is divided into 3 main sections:

- a. Technical information and reference
- b. Removal, disassembly, reassembly and installation
- c. Options

The format of the manual is designed to be followed in its entirety if complete disassembly and reassembly of the transmission is necessary. But if only one component of the transmission needs to be repaired, refer to the Table of Contents for the page numbers showing that component. For example, if you need to work on the Shift Bar Housing, you will find instructions for removal, disassembly and reassembly on page 47. Instructions for installation are on page

131. Service Manuals, Illustrated Parts Lists, Drivers Instructions, Driver Training Programs and other forms of product service information for these and other Fuller Transmissions are available upon request. A Technical Literature Order Form may be found in the back of this manual*. You may also obtain Service Bulletins, detailing information on product improvements, repair procedures and other service-related subjects by writing to the following address:

EATON CORPORATION
TRANSMISSION DIVISION
Technical Service Department
P.O. Box 4013
Kalamazoo, Michigan 49003
(616) 342-3000

Every effort has been made to ensure the accuracy of all information in this brochure. **However, Eaton Transmission Division makes no expressed or implied warranty or representation based on the enclosed information.** Any errors or omissions may be reported to Marketing Communications, Eaton Transmission Division, P.O. Box 4013, Kalamazoo, MI 49003.

MODEL DESIGNATIONS AND SPECIFICATIONS

Nomenclature: **RTO-11607L/LL**

Letter Designations

Roadranger®

Twin Countershaft

Overdrive

Number Designations

Denotes a Low ratio and a Low-Low ratio in addition to 8 highway ratios.

Denotes a Low ratio in addition to 8 highway ratios.

Forward Speeds

Multi-Mesh Gearing

x 100 = Nominal Torque Capacity

IMPORTANT: All Fuller Transmissions are identified by model and serial number. This information is stamped on the transmission identification tag and affixed to the case.

DO NOT REMOVE OR DESTROY THE TRANSMISSION IDENTIFICATION TAG.

Gear Ratios —

Model	Deep Reduction		Low Range				High Range				Reverse Low/High
	Rev.	LO-LO	LO	1st	2nd	3rd	4th	5th	6th	7th OD	
RTO-11607L	—	—	14.87	8.79	5.59	3.57	2.46	1.57	1.00	.76	11.89/3.33
RTO-11607LL	18.53	23.18	14.87	8.79	5.59	3.57	2.46	1.57	1.00	.76	11.89/3.33

LUBRICATION

Proper Lubrication . . . the Key to long transmission life

Proper lubrication procedures are the key to a good all-around maintenance program. If the oil is not doing its job, or if the oil level is ignored, all the maintenance procedures in the world are not going to keep the transmission running or assure long transmission life.

Eaton® Fuller® Transmissions are designed so that the internal parts operate in a bath of oil circulated by the motion of gears and shafts.

Thus, all parts will be amply lubricated if these procedures are closely followed:

1. **Maintain oil level. Inspect regularly.**
2. **Change oil regularly.**
3. **Use the correct grade and type of oil.**
4. **Buy from a reputable dealer.**

Lubrication Change and Inspection

Eaton® Roadranger® CD50 Transmission Fluid	
HIGHWAY USE—Heavy Duty and Mid-Range	
First 3,000 to 5,000 miles (4827 to 8045 Km)	Factory fill Initial drain
Every 10,000 miles (16090 Km)	Check fluid level Check for leaks
Heavy Duty Highway Change Interval	
Every 250,000 miles (402336 Km)	Change transmission fluid,
Mid-Range Highway Change Interval	
Every 100,000 miles (160,000 Km) or every 3 years whichever occurs first	Change transmission fluid.
OFF-HIGHWAY USE	
First 30 hours	Factory fill Initial drain,
Every 40 hours	Inspect fluid level Check for leaks
Every 500 hours	Change transmission fluid where severe dirt conditions exist.
Every 1,000 hours	Change transmission fluid (Normal off-highway use),
Heavy Duty Engine Lubricant or Mineral Gear Lubricant	
HIGHWAY USE	
First 3,000 to 5,000 miles (4827 to 8045 Km)	Factory fill Initial drain.
Every 10,000 miles (16090 Km)	Inspect lubricant level, Check for leaks,
Every 50,000 miles (80450 Km)	Change transmission lubricant,
OFF-HIGHWAY USE	
First 30 hours	Change transmission lubricant on new units
Every 40 hours	Inspect lubricant level Check for leaks
Every 500 hours	Change transmission lubricant where severe dirt conditions exist.
Every 1,000 hours	Change transmission lubricant (Normal off-highway use),

Change the oil filter when fluid or lubricant is changed.

Recommended Lubricants		
Type	Grade (SAE)	Fahrenheit (Celsius) Ambient Temperature
Eaton® Roadranger® CD50 Transmission Fluid	50	All
Heavy Duty Engine Oil	50	Above 10°F(-12°C.)
MI L-L-2104B C or D or API-SF or API-CD	40	Above 10°F(-12°C.)
(Previous API designations acceptable)	30	Below 10°F(-12°C.)
Mineral Gear Oil with rust and oxidation Inhibitor	90 80W	Above 10°F(-12°C.) Below 10°F(-12°C.)
API-GL-1		

The use of mild EP gear oil or multi-purpose gear oil is not recommended, but if these gear oils are used, be sure to adhere to the following limitations:

Do not use mild EP gear oil or multi-purpose gear oil when operating temperatures are above 230°F (110°C). Many of these gear oils, particularly 85W140, break down above 230°F and coat seals, bearings and gears with deposits that may cause premature failures. If these deposits are observed (especially a coating on seal areas causing oil leakage), change to Eaton Roadranger CD50 transmission fluid, heavy duty engine oil or mineral gear oil to assure maximum component life and to maintain your warranty with Eaton. (Also see "Operating Temperatures".)

Additives and friction modifiers are not recommended for use in Eaton Fuller transmissions.

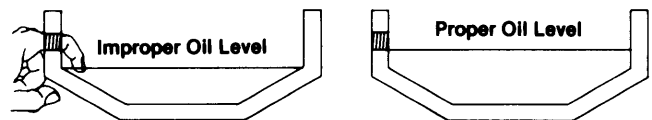

Proper Oil Level

Make sure oil is level with filler opening. Because you can reach oil with your finger does not mean oil is at proper level. One inch of oil level is about one gallon of oil.

Draining Oil

Drain transmission while oil is warm. To drain oil remove the drain plug at bottom of case. Clean the drain plug before re-installing.

Refilling

Clean case around filler plug and remove plug from side of case. Fill transmission to the level of the filler opening. If transmission has two filler openings, fill to level of both openings.

The exact amount of oil will depend on the transmission inclination and model. Do not over fill—this will cause oil to be forced out of the transmission.

When adding oil, types and brands of oil should not be mixed because of possible incompatibility.

LUBRICATION

Operating Temperatures —With Eaton® Roadranger® CD50 Transmission Fluid Heavy Duty Engine Oil and Mineral Oil

The transmission should not be operated consistently at temperatures above 250°F (120°C). However, intermittent operating temperatures to 300°F (149°C) will not harm the transmission. Operating temperatures above 250°F increase the lubricant's rate of oxidation and shorten its effective life. When the average operating temperature is above 250°F, the transmission may require more frequent oil changes or external cooling.

The following conditions in any combination can cause operating temperatures of over 250°F: (1) operating consistently at slow speeds, (2) high ambient temperatures, (3) restricted air flow around transmission, (4) exhaust system too close to transmission, (5) high horsepower, overdrive operation.

External oil coolers are available to reduce operating temperatures when the above conditions are encountered.

Transmission Oil Coolers are:

Recommended

- With engines of 350 H.P. and above with overdrive transmissions

Required

- With engines 399 H.P. and above with overdrive transmissions and GCW'S over 90,000 lbs.
- With engines 399 H.P. and above and 1400 Lbs.-Ft. or greater torque
- With engines 450 H.P. and above

— With EP or Multipurpose Gear Oil

Mild EP gear oil and multipurpose gear oil are not recommended when lubricant operating temperatures are above 230°F (110). In addition, transmission oil coolers are not recommended with these gear oils since the oil cooler materials may be attacked by these gear oils. The lower temperature limit and oil cooler restriction with these gear oils generally limit their success to milder applications.

Proper Lubrication Levels as Related to Transmission Installation Angles

If the transmission operating angle is more than 12 degrees, improper lubrication can occur. The operating angle is the transmission mounting angle in the chassis plus the percent of upgrade (expressed in degrees).

The chart below illustrates the safe percent of upgrade on which the transmission can be used with various chassis mounting angles. For example: if you have a 4 degree transmission mounting angle, then 8 degrees (or 14 percent of grade) is equal to the limit of 12 degrees. If you have a 0 degree mounting angle, the transmission can be operated on a 12 degree (21 percent) grade.

Anytime the transmission operating angle of 12 degrees is exceeded for an extended period of time the transmission should be equipped with an oil pump or cooler kit to insure proper lubrication.

Note on the chart the effect low oil levels can have on safe operating angles. Allowing the oil level to fall 1/2" below the filler plug hole reduces the degree of grade by approximately 3 degrees (5.5 percent).

Proper Lubrication Levels are Essential!

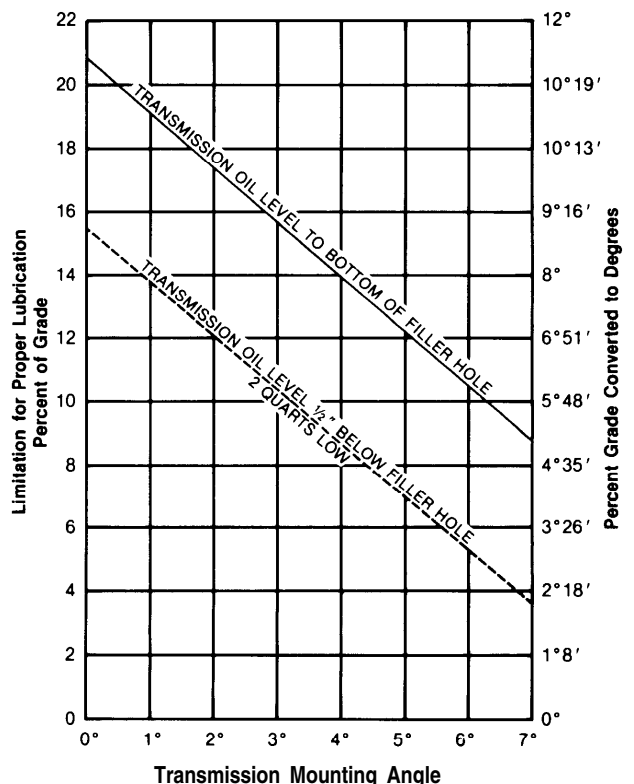

Dotted line showing "2 Quarts Low" is for reference only. Not recommended.

OPERATION

Shift Lever Patterns and Shifting Controls

“L” Models WITHOUT Deep Reduction —

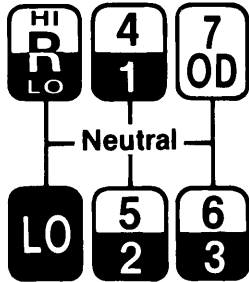

Shift LO-1-2-3 in LOW RANGE.
Range Shift . . .
And shift 4-5-6-7(O.D.) in HIGH RANGE.

“LL” Models WITH Deep Reduction —

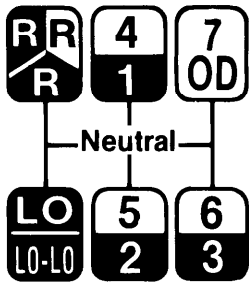

With Deep Reduction Lever/Button in the “OUT”/REARWARD position . . . Shift LO-1-2-3 in LOW RANGE.
Range Shift . . .
And shift 4-5-6-7(O.D.) in HIGH RANGE.

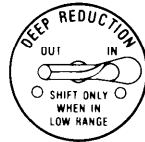
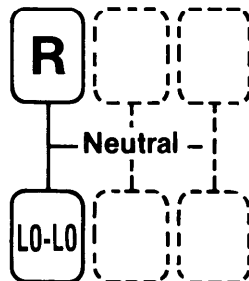

WHILE IN LOW RANGE ONLY and shift lever in LO . . .
LO-LO can be obtained by moving Deep Reduction Lever/Button to the “IN”/FORWARD position.

Range Control Valve (A-3546)

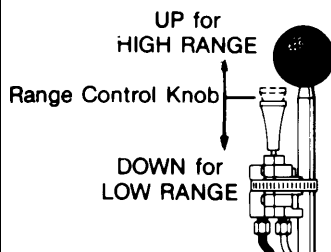

Master Control Valve (A-5010)

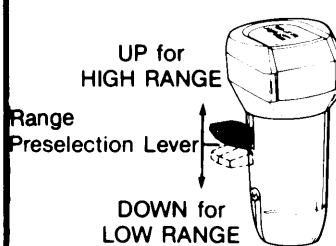

Master Control Valve (A-5015)

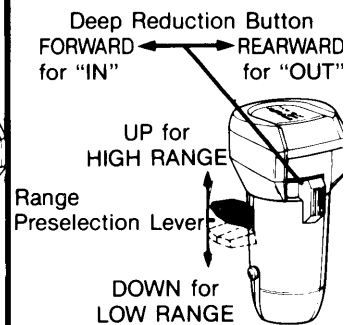

POWER FLOW

The transmission must efficiently transfer the engine's power, in terms of torque, to the vehicle's rear wheels. Knowledge of what takes place in the transmission during torque transfer is essential when trouble-shooting and making repairs as they become necessary.

Front Section Power Flow:

(Both Models)

1. Power (torque) from the vehicle's engine is transferred to the transmission's input shaft.
2. Splines of input shaft engage internal splines in hub of main drive gear.
3. Torque is split between the two countershaft drive gears.
4. Torque is delivered along both countershaft to mating countershaft gears of "engaged" mainshaft gear. The cross section view shown below illustrates LO/LO gear engagement.
5. Internal clutching teeth in hub of engaged mainshaft gear transfers torque to mainshaft through sliding clutch.
6. Mainshaft transfers torque directly to auxiliary drive gear.

Auxiliary Section Power Flow:

(RTO-11607LL LO/LO)

7. The auxiliary drive gear splits torque between the two auxiliary countershaft drive gears.
8. Torque is delivered along both auxiliary countershaft to the mating "engaged" deep reduction gear on output shaft.
9. Torque is transferred to output shaft through sliding clutch.
10. Output shaft delivers torque to driveline as LO/LO.

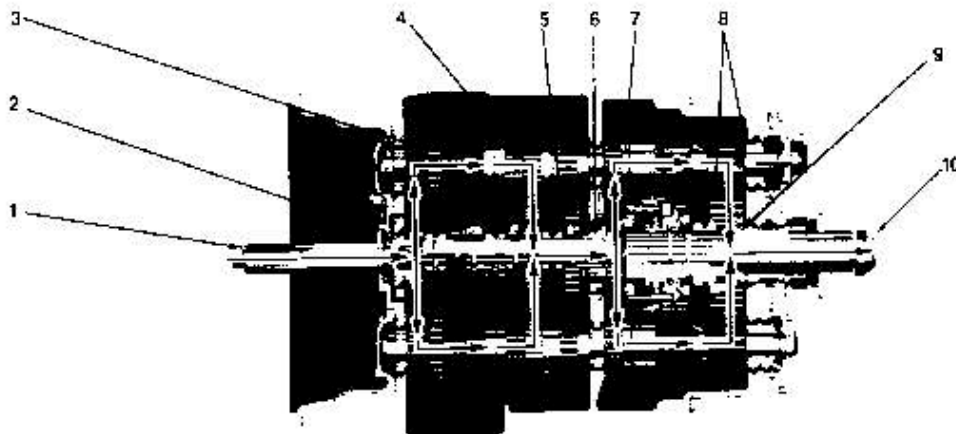

DEEP REDUCTION POWER FLOW

Figure 1

POWER FLOW

Auxiliary Section Power Flow: LOW RANGE (All Models)

7. The auxiliary drive gear splits torque between the two auxiliary countershaft drive gears.
8. Torque is delivered along both countershaft to "engaged" low range gear on range mainshaft or output shaft.
9. Torque is transferred to range mainshaft or output shaft through sliding clutch.
10. Torque is delivered to driveline as LOW RANGE.

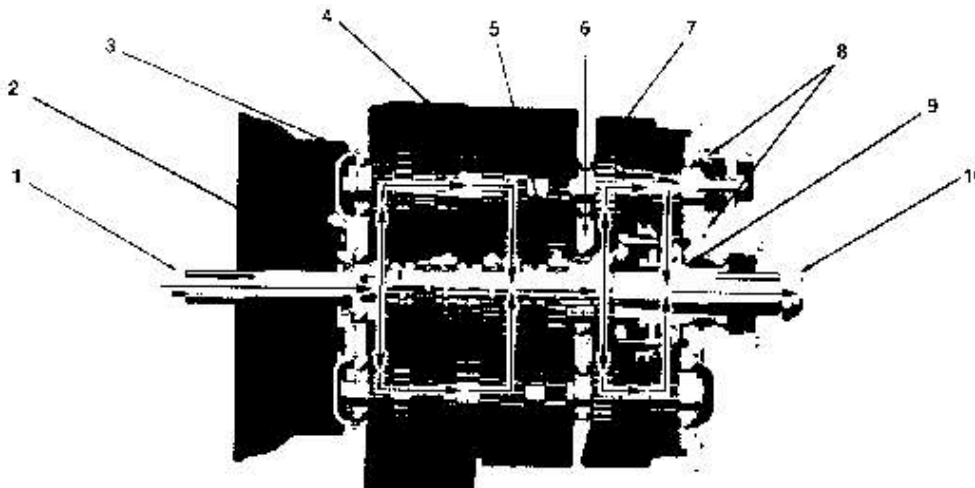

- Figure 2.

LOW RANGE POWER FLOW
(RTO-11607L Model Shown)

Auxiliary Section Power Flow: HIGH RANGE (All Models)

7. The auxiliary drive gear transfers torque directly to the range mainshaft or output shaft through "engaged" sliding clutch.
8. Torque is delivered through range mainshaft and/or output shaft to driveline as HIGH RANGE 4th.

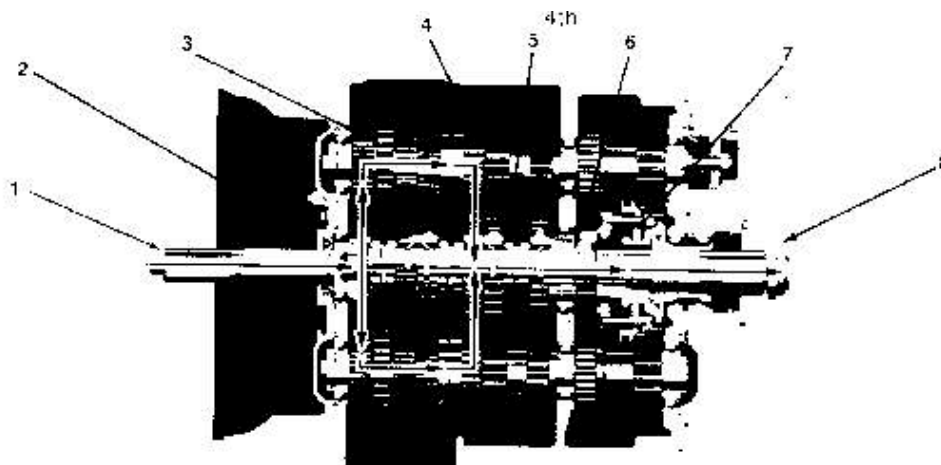

HIGH RANGE POWER FLOW
(RTO-11607L Model Shown)

Figure 3.

TIMING

All Fuller twin countershaft transmissions are “timed” at assembly. It is important that proper timing procedures are followed when reassembling the transmission. Timing assures that the countershaft gears will contact the mating mainshaft gears at the same time, allowing mainshaft gears to center on the mainshaft and equally divide the load.

Timing is a simple procedure of marking the appropriate teeth of a gear set prior to installation and placing them in proper mesh while in the transmission. In the front section, it is necessary to time only the drive gear set. And depending on the model, only the low range or deep reduction gear set is timed in the auxiliary section.

A. Marking countershaft drive gear teeth.

1. Prior to placing each countershaft assembly into case, clearly mark on each drive gear the gear tooth which is directly over the keyway in gear. (See illustration A.) This tooth is stamped with an “O” to aid identification.

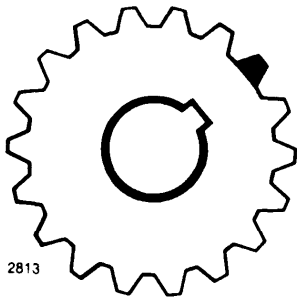

A. TOOTH ON COUNTERSHAFT DIRECTLY OVER KEYWAY MARKED FOR TIMING

B. Marking drive gear teeth.

1. Mark **any** two adjacent teeth on the drive gear.
2. Mark the two adjacent teeth on the drive gear which are directly opposite the first set marked. There should be an equal number of teeth between the markings on each side of gear. (See Illustration B.)

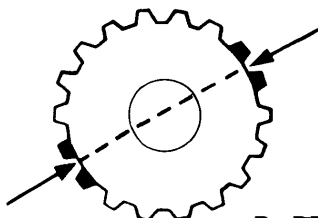

B. DRIVE GEAR TEETH CORRECTLY MARKED FOR TIMING

C. Meshing marked countershaft gear teeth with marked drive gear teeth. (After installing drive gear and mainshaft assemblies, the countershaft bearings are installed to complete countershaft installation.)

1. When installing bearings on the left countershaft, mesh the marked countershaft gear tooth between two marked teeth on the drive gear. Repeat the procedure when installing the right countershaft bearings. (See Illustration c.)

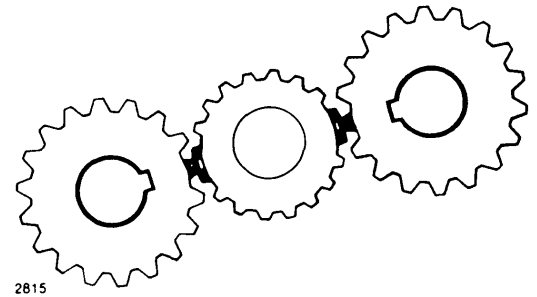

C. COUNTERSHAFT GEAR TEETH MESHED WITH DRIVE GEAR TEETH FOR CORRECT TIMING

D. Timing auxiliary section.

(In the auxiliary section, the low speed gear set is marked for timing instead of the drive gear set.)

1. Mark any two adjacent teeth on the large mainshaft low speed gear, then mark the two adjacent teeth directly opposite—the same procedure as used when marking the front section drive gear.
2. On each auxiliary countershaft assembly, mark the tooth on the small low speed gear which is stamped with an “O.”
3. Install the low speed gear and tailshaft assembly in auxiliary housing.
4. Partially install outer races of countershaft rear bearings in case bores.
5. Place the auxiliary countershaft assemblies into position, meshing marked tooth on each countershaft gear between marked teeth on low speed gear. Countershafts will be partially seated in rear bearing.
6. Fully install rear bearings to complete auxiliary countershaft installation.

TORQUE RECOMMENDATIONS

Correct torque application is extremely important to assure long transmission life and dependable performance. Over-tightening or under-tightening can result in a loose installation and, in many instances, eventually cause damage to transmission gears, shafts, and/or bearings. Use a torque wrench whenever possible to attain recommended lbs./ft. ratings. Do not torque capscrews dry.

FRONT SECTION: ALL MODELS

(1) MAIN DRIVE GEAR BEARING NUT,
250-300 Lbs./Ft., Apply
Loctite Grade 277 Sealant and
Stake to Input Shaft.

(6) FRONT BEARING COVER CAPSCREWS,
35-45 Lbs./Ft., 3/8-16 Threads.
Apply Loctite 242 to Threads.

(6) CLUTCH HOUSING NUTS.

180-190 (170-175*) Lbs./Ft.,
5/8-18 Threads. Use Lockwashers.

(4) SLAVE AIR VALVE CAPSCREWS,
8-12 Lbs./Ft., 1/4-20 Threads.
Apply Loctite 242 to Threads.

(1) NEUTRAL SIGNAL SWITCH PLUG,
35-50 Lbs./Ft., 3/4-16 Threads.

(5) SHIFT BLOCK AND YOKE LOCKSCREWS,
35-45 Lbs./Ft., 7/16-20 Threads, Secure
with Lockwire.

(16) SHIFT BAR HOUSING AND (4) SHIFT
LEVER HOUSING CAPSCREWS, 35-45 Lbs./Ft.,
3/8-16 Threads. Apply Loctite 242 to Threads.

(1) REVERSE SIGNAL SWITCH PLUG,
35-50 Lbs./Ft., 9/16-18 Threads,

(2) SUPPORT STUD NUTS,
170-185 Lbs./Ft., 5/8-18 Threads,
Use Lockwashers.

AUXILIARY SECTION:

L

AUXILIARY SECTION: LL

(6) SMALL P.T.P. COVER CAPSCREWS
20-25 Lbs./Ft., 3/8-16 Threads.
Apply Loctite 242 to Threads.

(8) LARGE P.T.O. COVER CAPSCREWS,
50-65 Lbs./Ft., 7/16-14 Threads.
Apply Loctite 242 to Threads.

(4) HAND HOLE COVER CAPSCREWS,
20-25 Lbs./Ft., 5/16-18 Threads.

(4) CLUTCH HOUSING CAPSCREWS, 90-100
(70-75*) Lbs./Ft., 1/2-13 Threads, Use Lockwashers.

*With Aluminum Clutch Housing

(1) OIL DRAIN PLUG,
45-55 Lbs./Ft., 3/4 Pipe Threads.

(6) MAINSHAFT REAR BEARING RETAINER
CAPSCREWS, 35-45 Lbs./Ft.
3/8-16 Threads, Secure with Lockwire.

(1) OIL FILL PLUG,
60-75 Lbs./Ft., 1-1/4 Pipe Threads.

(2) REVERSE IDLER SHAFT NUTS,
50-60 Lbs./Ft., 5/8-18 Threads.

TORQUE RECOMMENDATIONS

AUXILIARY SECTION:

RTO-11607LL Model Shown
Torque Recommendations for RTO-11607L
Auxiliary are the same.

(2) AIR FILTER/REGULATOR MOUNTING
CAPSCREWS 8-12 Lbs./Ft., 1/4-20 Threads.
Apply Loctite 242 to Threads.

(1) RANGE CYLINDER SHIFT BAR NUT,
70-85 Lbs./Ft., 5/8-18 Threads.

(2) RANGE SHIFT YOKE CAPSCREWS,
50-65 Lbs./Ft., 1/2-20 Threads,
Secure with Lockwire.

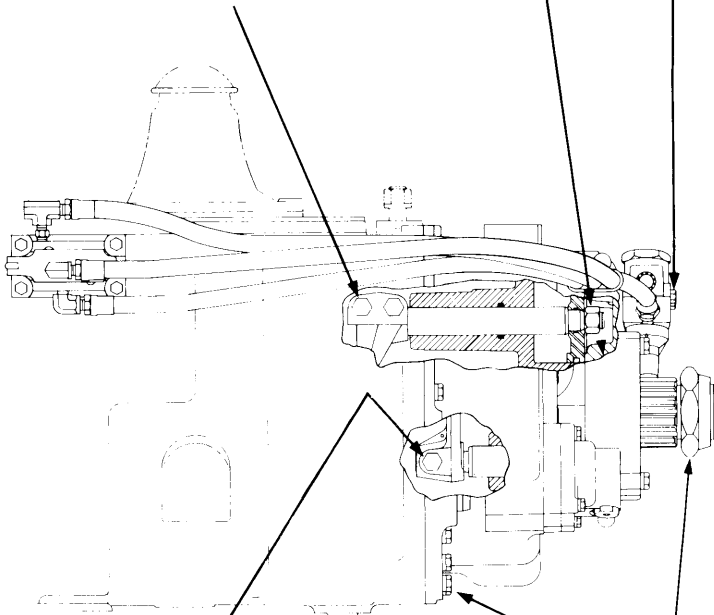

(1) REDUCTION OR SPLITTER SHIFT
YOKE LOCKSCREW,
35-45 Lbs./Ft., 7/16-20 Threads,
Secure with Lockwire.

(19) AUXILIARY HOUSING CAPSCREWS,
35-45 Lbs./Ft., 3/8-16 Threads.
Apply Loctite 242 to Threads.

(1) OUTPUT SHAFT NUT,
450-500 Lbs./Ft.,
2-16 Threads Oiled at
Vehicle Installation.

(6) MAINSHAFT REAR BEARING COVER
CAPSCREWS, 35-45 Lbs./Ft., 3/8-16 Threads.
Apply Loctite 242 to Threads.

(4) RANGE CYLINDER MOUNTING
CAPSCREWS, 35-45 Lbs./Ft., 3/8-16 Threads.
Apply Loctite 242 to Threads.

(4) RANGE CYLINDER COVER
CAPSCREWS, 35-45 Lbs./Ft., 3/8-16 Threads.
Apply Loctite 242 to Threads.

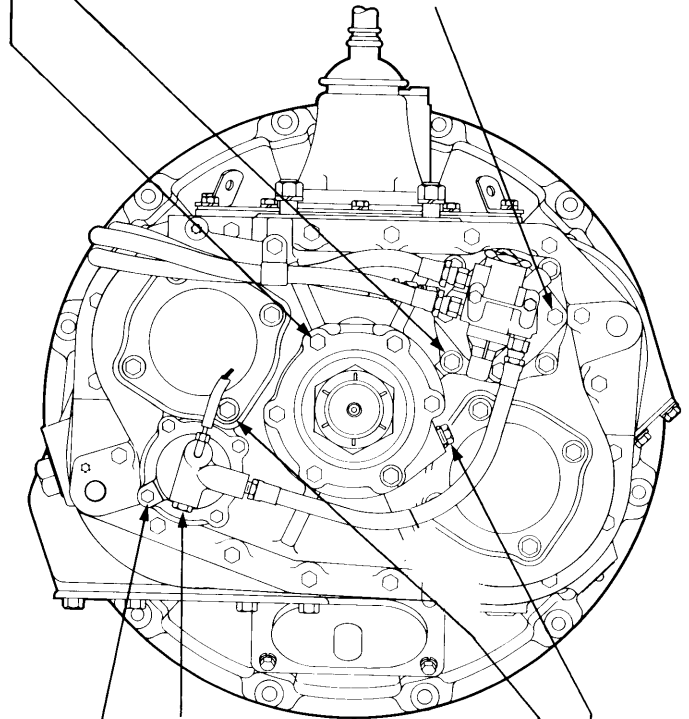

See NOTE.

(4) REDUCTION OR SPLITTER CYLINDER
COVER CAPSCREWS, 20-25 Lbs./Ft.,
5/16-18 Threads.
Apply Loctite 242 to Threads.

(8) COUNTERSHAFT REAR BEARING
COVER CAPSCREWS, 35-45 Lbs./Ft.,
3/8-16 Threads.
Apply Loctite 242 to Threads.

(1) SPEEDOMETER HOUSING PLUG,
35-50 Lbs./Ft., 13/16-20 Threads.
Apply Loctite 242 to Threads.

NOTE: If insert valve is used in reduction or splitter cylinder cover. . .

(1) RETAINING NUT/PLUG, 40-50 Lbs./Ft., 5/8-18 Threads.

TOOL REFERENCE

Some repair procedures pictured in this manual show the use of specialized tools. Their actual use is recommended as they make transmission repair easier, faster, and prevent costly damage to critical parts.

But for the most part, ordinary mechanic's tools such as socket wrenches, screwdrivers, etc., and other standard shop items such as a press, mauls and soft bars are all that is needed to successfully disassemble and reassemble any Fuller® Transmission.

The specialized tools listed below can be obtained from a tool supplier or made from dimensions as required by the individual user. Detailed Fuller® Tool Prints are available upon request by writing.

Eaton Corporation
Transmission Division
Technical Service Dept.
P.O. Box 4013
Kalamazoo, Michigan 49003

PAGE	TOOL	HOW OBTAINED
57	Auxiliary Section Hanger Bracket	Made from Fuller Print T-22823
46	Tension Spring Driver	Made from Fuller® Print T-11938
100	Snap Ring Pliers	Tool Supplier
101	Impact Puller (1/2-13 Threaded End)	Tool Supplier
94	Bearing Drivers (Flanged-End)	Made from Fuller® Print Series T-10842*
87	Quill Snap Ring Installer	Made from Fuller® Print T-22917-F
127	Torque Wrench, 1000 Lbs./Ft. Capacity	Tool Supplier
98	Input Shaft Nut Installer	Made from Fuller® Print T-22553-A
*Dimensions necessary to determine specific tool number required.		

PREVENTIVE MAINTENANCE CHECK CHART

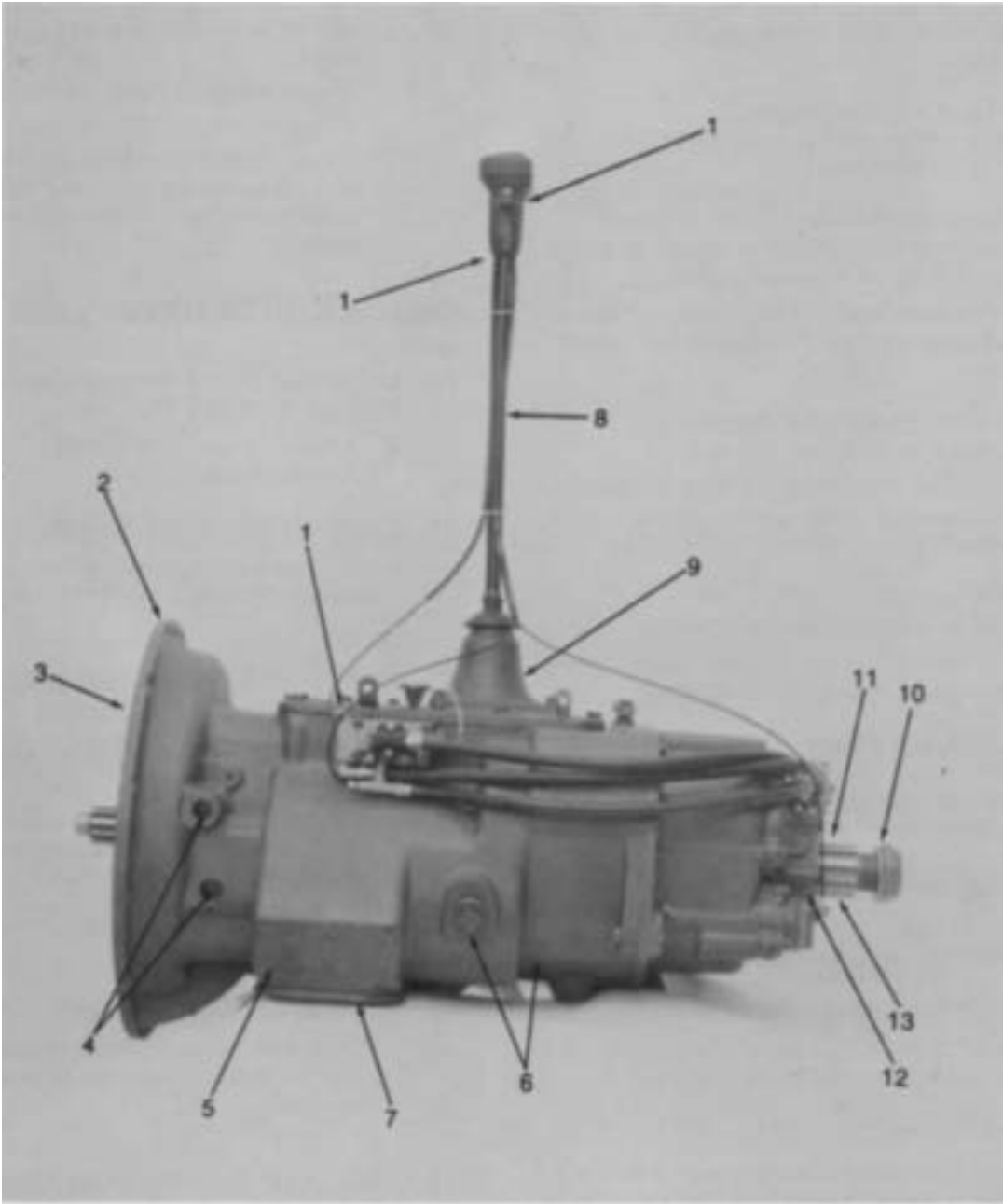

PREVENTIVE MAINTENANCE

PREVENTIVE MAINTENANCE CHECK CHART

CHECKS WITHOUT PARTIAL DISASSEMBLY OF CHASSIS OR CAB

- 1. Air System and Connections**
 - a. Check for leaks, worn air lines, loose connections and capscrews. See AIR SYSTEM.
- 2. Clutch Housing Mounting**
 - a. Check all capscrews in bolt circle of clutch housing for looseness.
- 3. Clutch Release Bearing (Not Shown)**
 - a. Remove hand hole cover and check radial and axial clearance in release bearing.
 - b. Check relative position of thrust surface of release bearing with thrust sleeve on push-type clutches.
- 4. Clutch Pedal Shaft and Bores**
 - a. Pry upward on shafts to check wear.
 - b. If excessive movement is found, remove clutch release mechanism and check bushings in bores and wear on shafts.
- 5. Lubricant**
 - a. Change at specified service intervals.
 - b. Use only the types and grades as recommended. See LUBRICATION.
- 6. Filler and Drain Plugs**
 - a. Remove filler plugs and check level of lubricant at specified intervals. Tighten filler and drain plugs securely.
- 7. Capscrews and Gaskets**
 - a. Check all capscrews, especially those on PTO covers and rear bearing covers for looseness which would cause oil leakage. See TORQUE RECOMMENDATIONS.
 - b. Check PTO opening and rear bearing covers for oil leakage due to faulty gasket.
- 8. Gear Shift Lever**
 - a. Check for looseness and free play in housing. If lever is loose in housing, proceed with Check No. 9.

9. Gear Shift Lever Housing Assembly

- a. Remove air lines at slave valve and remove the gear shift lever housing assembly from transmission.
- b. Check tension spring and washer for set and wear.
- c. Check the gear shift lever spade pin and slot for wear.
- d. Check bottom end of gear shift lever for wear and check slot of yokes and blocks in shift bar housing for wear at contact points with shift lever.

CHECKS WITH DRIVE LINE DROPPED

10. Universal Joint Companion Flange or Yoke Nut

- a. Check for tightness. Tighten to recommended torque.

11. Output Shaft (Not Shown)

- a. Pry upward against output shaft to check radial clearance in mainshaft rear bearing.

CHECKS WITH UNIVERSAL JOINT COMPANION FLANGE OR YOKE REMOVED

NOTE: If necessary, use a solvent and shop rag to clean sealing surface of companion flange or yoke. DO NOT USE A CROCUS CLOTH, EMERY PAPER OR OTHER ABRASIVE MATERIALS THAT WILL MAR SURFACE FINISH.

12. Splines on Output Shaft

- a. Check for wear from movement and chucking action of the universal joint companion flange or yoke.

13. Mainshaft Rear Bearing Cover

- a. Check oil seal for wear.

PRECAUTIONS

Disassembly

It is assumed in the detailed assembly instructions that the lubricant has been drained from transmission, the necessary linkage and air lines were disconnected, and the transmission has been removed from vehicle chassis. Removal of the gear shift lever housing assembly (or remote control assembly) is included in the detailed instructions (Disassembly and Reassembly—Shifting Controls); however, this assembly **MUST** be detached from shift bar housing before transmission can be removed.

FOLLOW CLOSELY EACH PROCEDURE IN THE DETAILED INSTRUCTIONS, MAKING USE OF THE TEXT, ILLUSTRATIONS AND PHOTOGRAPHS PROVIDED.

- 1. BEARINGS** - Carefully wash and relubricate all reusable bearings as removed and protectively wrap until ready for use. Remove bearings planned to be reused with pullers designed for this purpose.
- 2. ASSEMBLIES** - When disassembling the various assemblies, such as the mainshaft, countershaft, and shift bar housing, lay all parts on a clean bench in the same sequence as removed. This procedure will simplify reassembly and reduce the possibility of losing parts.
- 3. SNAP RINGS** - Remove snap rings with pliers designed for this purpose. Snap rings removed in this manner can be reused.
- 4. INPUT SHAFT** - The input shaft can be removed from transmission without removing the countershaft, mainshaft, or main drive gear. Special procedures are required and provided in this manual.
- 5. CLEANLINESS** - Provide a clean place to work. It is important that no dirt or foreign material enters the unit during repairs. Dirt is an abrasive and can damage bearings. It is always good practice to clean the outside of the unit before starting the planned disassembly.
- 6. WHEN USING TOOLS TO MOVE PARTS** - Always apply force to shafts, housings, etc, with restraint. Movement of some parts is restricted. Never apply force to the part being driven after it stops solidly. The use of soft hammers, bars and mauls for all disassembly work is recommended.

Inspection

Before reassembling the transmission, check each part carefully for abnormal or excessive wear and damage to determine reuse or replacement. When replacement is necessary, use only genuine Fuller® parts to assure continued performance and extended life from your unit.

Since the cost of a new part is generally a small fraction of the total cost of downtime and labor, avoid reusing a questionable part which could lead to additional repairs and expense soon after initial reassembly. To aid in determining the reuse or replacement of any transmission part, consideration should also be given to the unit's history, mileage, application, etc.

Recommended inspection procedures are provided in the following check list.

A. BEARINGS

1. Wash all bearings in clean solvent. Check balls, rollers and raceways for pitting, discoloration, and spalled areas. Replace bearings that are pitted, discolored, or spalled.
2. Lubricate bearings that are not pitted, discolored, or spalled and check for axial and radial clearances.
Replace bearings with excessive clearances.
3. Check bearing fits. Bearing inner races should be tight to shaft; outer races slightly tight to slightly loose in case bore. If bearing spins freely in bore, however, the case should be replaced.

B. GEARS

1. Check gear teeth for frosting and pitting. Frosting of gear tooth faces present no threat of transmission failure. Often in continued operation of the unit, frosted gears will "heal" and not progress to the pitting stage. In most cases, gears with light to moderate pitted teeth have considerable gear life remaining and can be reused. But gears with advanced stage pitting should be replaced.
2. Check for gears with clutching teeth abnormally worn, tapered, or reduced in length from clashing in shifting. Replace gears found in any of these conditions.

PRECAUTIONS

Inspection (Cont.)

3. Check axial clearance of gears. Where excessive clearance is found, check gear snap ring, washer, spacer, and gear hub for excessive wear. Maintain .005" to .012" axial clearance between mainshaft gears.

C. SPLINES

1. Check splines on all shafts for abnormal wear. If sliding clutch gears, companion flange, or clutch hub have worn into the sides of the splines, replace the specific shaft affected.

D. TOLERANCE/LIMIT WASHERS

1. Check surfaces of all limit washers. Washers scored or reduced in thickness should be replaced.

E. REVERSE IDLER GEAR ASSEMBLIES

1. Check for excessive wear from action of roller bearings.

F. GRAY IRON PARTS

1. Check all gray iron parts for cracks and breaks. Replace or repair parts found to be damaged. Heavy castings may be welded or brazed provided the cracks do not extend into bearing bores or bolting surfaces. When welding, however, never place the ground so as to allow current to pass through the transmission.

G. CLUTCH RELEASE PARTS

1. Check clutch release parts. Replace yokes worn at cam surfaces and bearing carrier worn at contact pads.
2. Check pedal shafts. Replace those worn at bearing surfaces.

H. SHIFT BAR HOUSING ASSEMBLY

1. Check for wear on shift yokes and blocks at pads and lever slot. Replace excessively worn parts.
2. Check yokes for correct alignment. Replace sprung yokes.
3. Check lockscrews in yokes and blocks. Tighten and rewire those found loose.
4. If housing has been disassembled, check neutral notches of shift bars for wear from interlock balls.

I. GEAR SHIFT LEVER HOUSING ASSEMBLY

1. Check spring tension on shift lever. Replace tension spring and washer if lever moves too freely.
2. If housing is disassembled, check spade pin and corresponding slot in lever for wear. Replace both parts if excessively worn.

J. BEARING COVERS

1. Check covers for wear from thrust to adjacent bearing. Replace covers damaged from thrust of bearing outer race.
2. Check bores of covers for wear. Replace those worn oversize.

K. OIL RETURN THREADS AND SEALS

1. Check oil return threads in front bearing cover. If sealing action of threads has been destroyed by contact with input shaft, replace bearing cover.
2. Check oil seal in mainshaft rear bearing cover. If sealing action of lip has been destroyed, replace seal.

L. SLIDING CLUTCHES

1. Check all shift yokes and yoke slots in sliding clutches for extreme wear or discoloration from heat.
2. Check engaging teeth of sliding clutches for partial engagement pattern.

M. SYNCHRONIZER ASSEMBLY

1. Check synchronizer for burrs, uneven and excessive wear at contact surface, and metal particles.
2. Check blocker pins for excessive wear or looseness.
3. Check synchronizer contact surfaces on the auxiliary drive and low range gears for excessive wear.

N. O-RINGS

1. Check all O-rings for cracks or distortion. Replace if worn.

PRECAUTIONS

Reassembly

Make sure that interiors of case and housings are clean. It is important that dirt and other foreign materials be kept out of the transmission during reassembly. Dirt is an abrasive and can damage polished surfaces of bearings and washers. Use certain precautions, as listed below, during reassembly.

1. **GASKETS** - Use new gaskets throughout the transmission as it is being rebuilt. Make sure all gaskets are installed. An omission of any gasket can result in oil leakage or misalignment of bearing covers.
2. **CAPSCREWS** - To prevent oil leakage, use Loctite 242 thread sealant on all capscrews. For torque ratings, see TORQUE RECOMMENDATIONS.
3. **O-RINGS** - Lubricate all O-rings with silicon lubricant.
4. **ASSEMBLY** - Refer to the illustrations provided in the detailed disassembly instructions as a guide to reassembly.
5. **INITIAL LUBRICATION** - Coat all limit washers and splines of shafts with Lubriplate during reassembly to prevent scoring and galling of such parts.
6. **AXIAL CLEARANCES** - Maintain original axial clearances of .005" to .012" for mainshaft gears.
7. **BEARINGS** - Use of flanged-end bearing drivers is recommended for the installation of bearings. These special drivers apply equal force to both bearing races, preventing damage to balls/rollers and races while maintaining correct bearing alignment with bore and shaft. Avoid using a tubular or sleeve-type driver, whenever possible, as force is applied to only one of the bearing races. See TOOL REFERENCE.
8. **UNIVERSAL JOINT COMPANION FLANGE OR YOKE** - Pull the companion flange or yoke tightly into place with the output shaft nut, using 450-500 foot-pounds of torque. Make sure the speedometer drive gear or a replacement spacer of the same width has been installed. Failure to pull the companion flange or yoke tightly into place will permit the output shaft to move axially with resultant damage to the rear bearing.

IMPORTANT: REFER TO THE APPROPRIATE ILLUSTRATED PARTS LIST (SPECIFIED BY MODEL SERIES) TO ENSURE THAT PROPER PARTS ARE USED DURING REASSEMBLY OF THE TRANSMISSION.

CHANGING INPUT SHAFT

Special Procedure For Changing Input Shaft

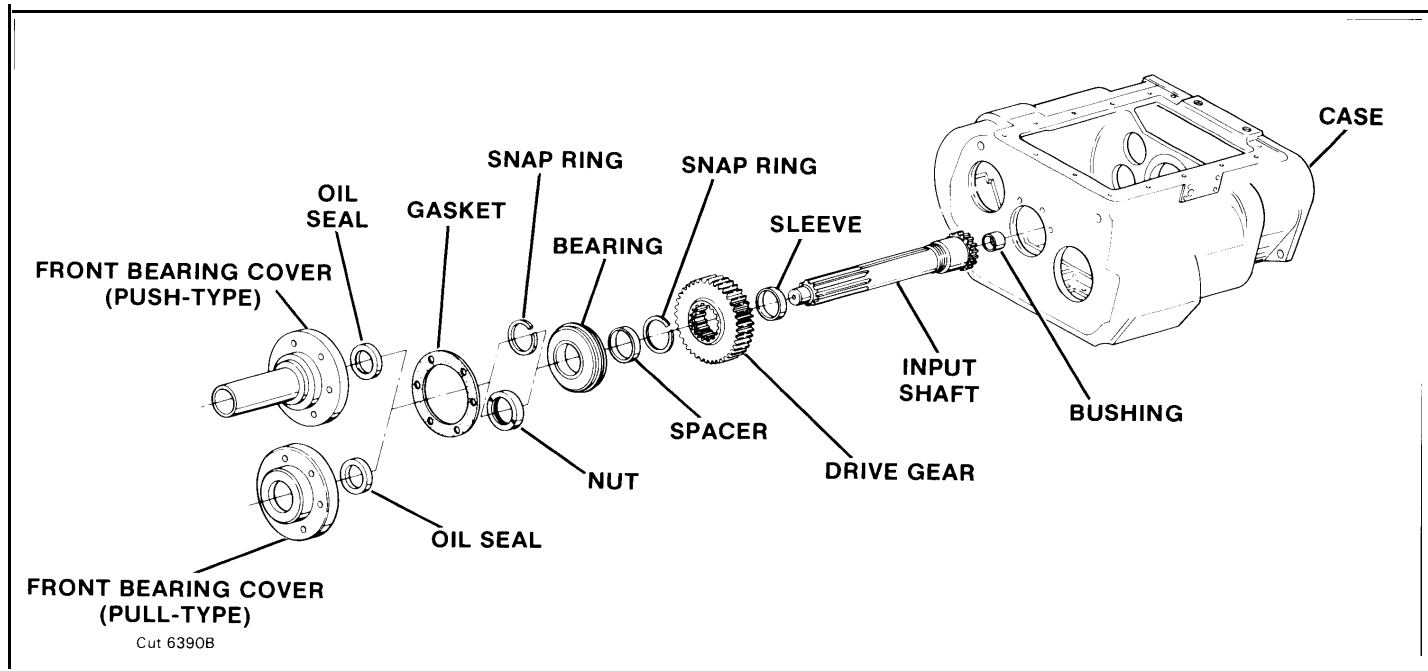

NOTE: In some cases in field repair it may be necessary to replace only the input shaft due to clutch wear on the splines.

In these instances, the input shaft can be removed without disassembling the transmission other than removing the shifting bar housing. Removal of the clutch housing is optional. Following is the detailed procedure.

A. INPUT SHAFT REMOVAL

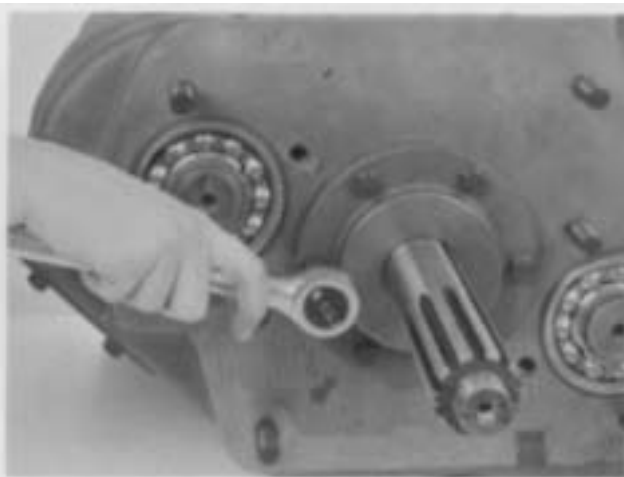

1. Remove the gear shift lever housing assembly (or remote control assembly) from shift bar housing, if necessary, and the shift bar housing assembly from transmission case.

2. Remove the front bearing cover and gasket.

CHANGING INPUT SHAFT

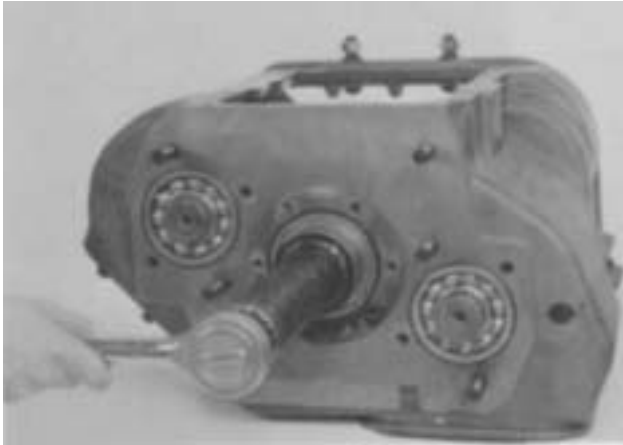

3. Remove the drive gear bearing nut (left hand threads).
Suggestion: For removal of nut ONLY, engage two mainshaft sliding clutches into gear to prevent the input from rotating.

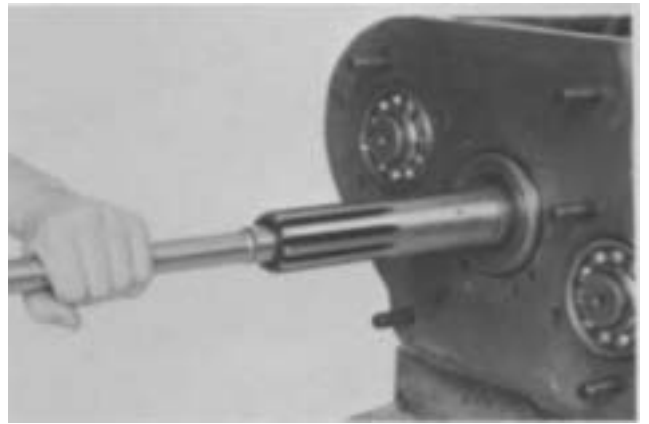

6. Drive the input shaft back through the bearing and into the case as far as possible. Drive the shaft forward again to free the input shaft bearing from the bore in the case.

NOTE: If this procedure does not free the bearing from its bore, repeat steps 4 through 6.



4. Drive the input shaft as far forward as possible.



7. Pry the bearing from the input shaft with two large screwdrivers.
8. Remove the spacer from the input shaft.



5. Tap the input shaft down to cock the input shaft bearing in its bore.

CHANGING INPUT SHAFT



9. From the front of transmission, remove the snap ring from I.D. of main drive gear using two small screwdrivers. If mainshaft was previously locked in two gears, it may become necessary to place sliding clutches in the neutral position to rotate input shaft and mainshaft for removal of snap ring.
10. Pull the input shaft forward from the splines of the drive gear.

4. Install spacer on input shaft.

B. INPUT SHAFT INSTALLATION



1. If necessary, install bushing in pocket of input shaft.
2. Install new input shaft into splines of main drive gear just far enough to expose snap ring groove in I.D. of drive gear.
3. Install snap ring in groove of drive gear.

5. Move the clutch gear forward to contact end of input shaft in hub of drive gear. Block between rear of sliding clutch and front of the overdrive gear. When installing bearing this will hold input shaft in position to seat the bearing properly.

CHANGING INPUT SHAFT

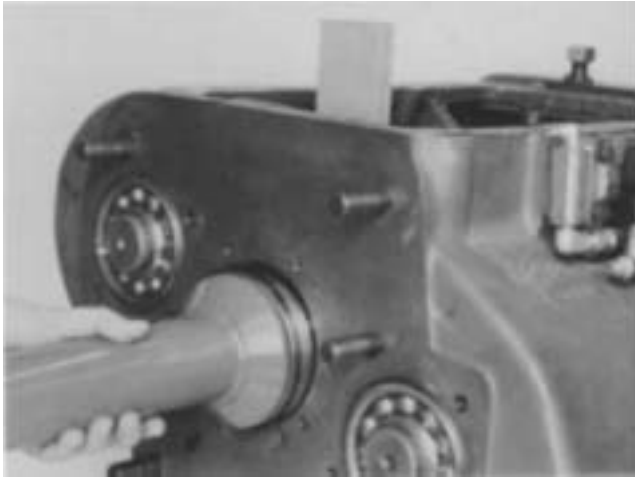

6. Using a flanged-end driver, install the drive gear bearing on shaft and into case bore. When applying force to driver, use caution so as not to damage bearing shield.
7. Remove the blocking from the mainshaft.

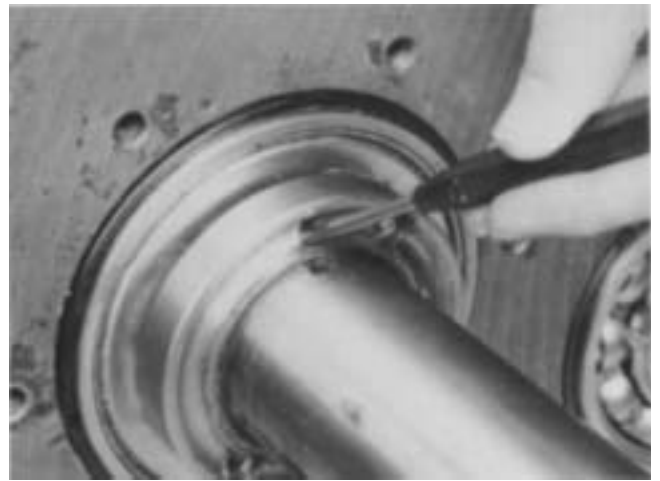

10. With a punch and maul, peen the nut into the two milled slots of input shaft, using caution so as not to distort O.D. of nut.

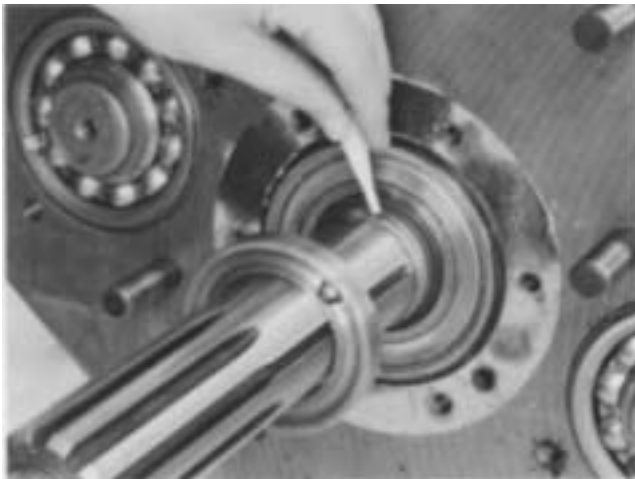

8. Apply Fuller adhesive sealant #71204 or equivalent to the cleaned threads of input shaft and nut, using caution so as not to contaminate bearing with sealant.
9. Engage two mainshaft sliding clutches into gear to prevent the mainshaft from rotating and install the new drive gear bearing nut, left-hand threads, on input shaft. Tighten nut with 250-300 Lbs./ Ft. of torque. **DO NOT REUSE OLD NUT.**

Suggestion: To avoid damaging the O.D. of nut, use the tool specifically designed for this purpose. See TOOL REFERENCE.



11. To facilitate proper reinstallation of the shift bar housing assembly on case, make sure mainshaft sliding clutches are placed in the neutral position.
12. Reinstall the shift bar housing assembly, the front bearing cover and all other parts and assemblies previously removed, making sure to replace the gaskets used.

NOTE: The above instructions are for changing the input shaft only. To change the drive gear, complete disassembly of the front section is required.

AIR SYSTEM

RT0-11607L

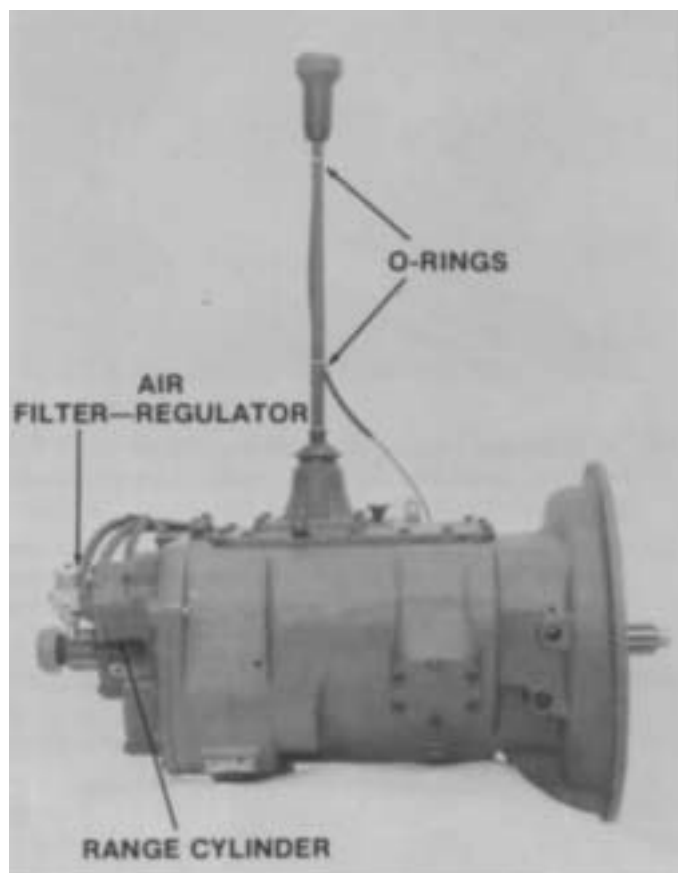
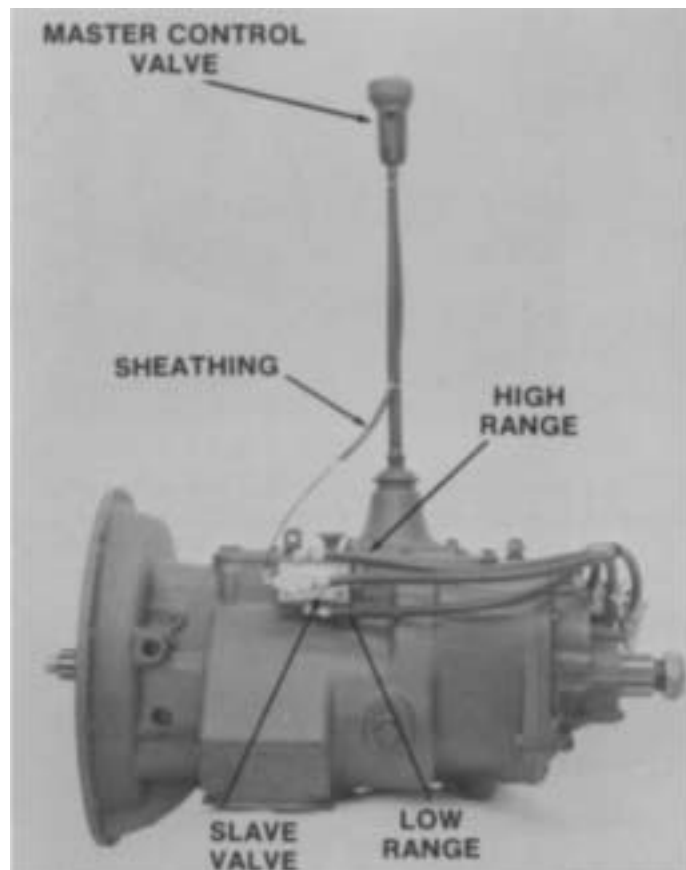

AIR SYSTEM

RT0-11607LL

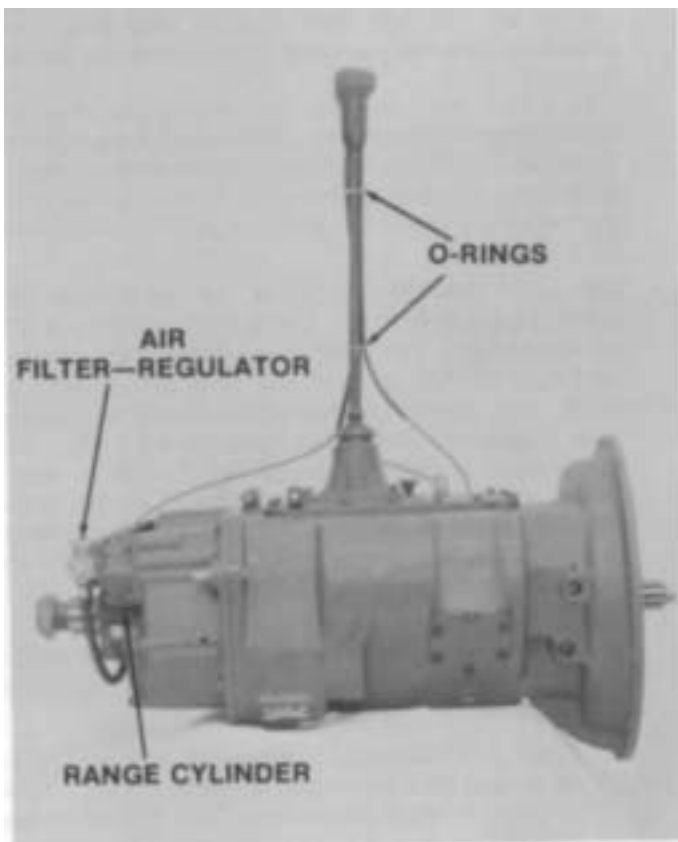
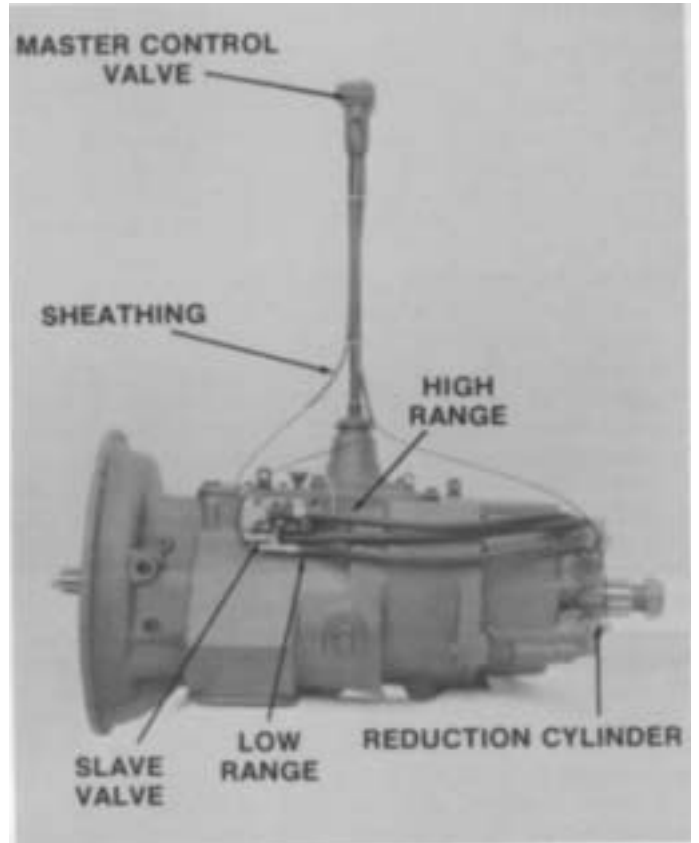

AIR SYSTEM

RANGE SHIFT AIR SYSTEM - ALL MODELS

Operation

The Range Shift Air System consists of the air filter/regulator, slave valve, a Range Control Valve or Master Control Valve, range cylinder, fittings and connecting air lines. See Air System Schematics.

CONSTANT AIR from the air filter/regulator is supplied to the "S" or Supply Port of slave valve and passed through to the INLET or "S" Port of control valve.

WHILE IN LOW RANGE, the control valve is OPEN and AIR is returned to slave valve at the "P" or End Port. This signals the valve to supply AIR in line between the Low Range or "L" Port of slave valve and the Low Range Port of range cylinder housing. AIR received at this port moves the range piston to the rear and causes the auxiliary low range gear to become engaged.

WHILE IN HIGH RANGE, the control valve is CLOSED and NO AIR is returned to the slave valve. This signals the slave valve to supply AIR in line between the High Range or "H" Port of valve and the High Range Port of range cylinder cover. AIR received at this port moves the range piston forward to engage the auxiliary drive gear with sliding clutch and bypass the low range gear set.

Range shifts can be made ONLY when the gear shift lever is in, or passing through, neutral. Thus, the range desired can be PRESELECTED while the shift lever is in a gear position. As the lever is moved through neutral, the actuating plunger in the shift bar housing releases the slave valve piston, allowing it to move to the selected range position.

Troubleshooting

If the transmission fails to make a range shift or shifts too slowly, the fault may be in the Range Shift Air System or actuating components of the shift bar housing assembly.

To locate the trouble, the following checks should be made with normal vehicle air pressure applied to the system, but with the engine off.

CAUTION: NEVER WORK UNDER A VEHICLE WHILE ENGINE IS RUNNING as personal injury MAY result from the sudden and unintended movement of vehicle under power.

1. INCORRECT AIR LINE HOOK-UPS

(See Air System Schematics)

With the gear shift lever in neutral, move the control that provides range selection UP and DOWN.

- A. If the air lines are crossed between control valve and slave valve, there will be CONSTANT AIR flowing from the exhaust port of control valve WHILE IN HIGH RANGE.

- B. If the air lines are crossed between the slave valve and range cylinder, the transmission gearing will not correspond with the range selection. A LOW RANGE selection will result in a HIGH RANGE engagement and vice versa.

2. AIR LEAKS

With the gear shift lever in neutral, coat all air lines and fittings with soapy water and check for leaks, moving the control that provides range selection UP and DOWN.

- A. If there is a steady leak from the exhaust port of control valve, O-rings and/or related parts of the control valve are defective.
- B. If there is a steady leak from breather of slave valve: an O-ring in valve is defective, or there is a leak past O-rings of range cylinder piston.
- C. If transmission fails to shift into LOW RANGE or is slow to make the range shift and the case is pressurized, see Check Note 7 of this section.
- D. Tighten all loose connections and replace defective O-rings and parts.

3. AIR FILTER/REGULATOR

(See illustration, Page 26.)

With the gear shift lever in neutral, check the breather of air filter/regulator assembly. There should be NO AIR leaking from this port. The complete assembly should be replaced if a steady leak is found.

Cut off the vehicle air supply to the air filter/regulator assembly, disconnect the air line at fitting in Supply OUTLET and install an air gauge in opened port. Bring the vehicle air pressure to normal. Regulated air pressure should be 57.5 to 62.5 PSI.

DO NOT ADJUST SCREW AT BOTTOM OF REGULATOR TO OBTAIN CORRECT READINGS. The air regulator has been PREADJUSTED within the correct operating limits. Any deviation from these limits, especially with regulators that have been in operation for some time, is likely to be caused by dirt or worn parts. If replacement or cleaning of the filter element does nothing to correct the air pressure readings, replace the complete assembly, as the air regulator is nonserviceable.

4. CONTROL VALVE (See Pages 27 and 28.)

With the gear shift lever in neutral, select HIGH RANGE and disconnect the 1/8" O.D. airline at the OUTLET or "P" Port of control valve.

- A. When LOW RANGE is selected, a steady blast of air will flow from opened port. Select HIGH RANGE to shut off air flow. This indicates the control valve is operating properly. Reconnect air line.

AIR SYSTEM

- B. If control valve does not operate properly, check for restrictions and air leaks. Leaks indicate defective or worn O-rings.

5. HIGH RANGE OPERATION

With the gear shift lever in neutral, select LOW RANGE and disconnect the 1/4" I.D. air line at the port of range cylinder cover. Make sure this line leads from the High Range or "H" Port of slave valve.

- A. When HIGH RANGE is selected, a steady blast of air should flow from disconnected line. Select LOW RANGE to shut off air flow.
- B. Move the shift lever to a gear position and select HIGH RANGE. There should be NO AIR flowing from disconnected line. Return the gear shift lever to the neutral position. There should now be a steady flow of air from disconnected line. Select LOW RANGE to shut off air flow and reconnect air line.
- C. If the air system does not operate accordingly, the slave valve or actuating components of the shift bar housing assembly are defective.

IMPORTANT: RANGE PRESELECTION

The plunger pin, located in case bore between the slave valve and actuating plunger of shift bar housing, prevents the slave valve from operating while the shift lever is in a gear position. When the lever is moved to or through the neutral position, the pin is released and the slave valve becomes operational.

6. LOW RANGE OPERATION

With the gear shift lever in neutral, select HIGH RANGE and disconnect the 1/4" I.D. air line at the fitting on range cylinder housing. Make sure this line leads from the Low Range or "L" Port of slave valve.

- A. When LOW RANGE is selected, a steady blast of air should flow from disconnected line. Select HIGH RANGE to shut off air flow.
- B. Move the shift lever to a gear position and select LOW RANGE. There should be NO AIR flowing from disconnected line. Return the gear shift lever to the neutral position. There should now be a steady flow of air from disconnected line. Select HIGH RANGE to shut off air flow and reconnect air line.
- c. If the air system does not operate accordingly, the slave valve or actuating components of the shift bar housing assembly are defective.

7. RANGE CYLINDER (Refer to the following illustration.)

If any of the seals in the range cylinder assembly are defective, the range shift will be affected.

- A. Leak at either O-ring A results in complete failure to make a range shift; steady flow of air from breather of slave valve in both ranges.
- B. Leak at gasket B results in a steady flow of air to atmosphere while in HIGH RANGE.
- C. Leak at O-ring C results in a slow shift to LOW RANGE; pressurizing of transmission case.

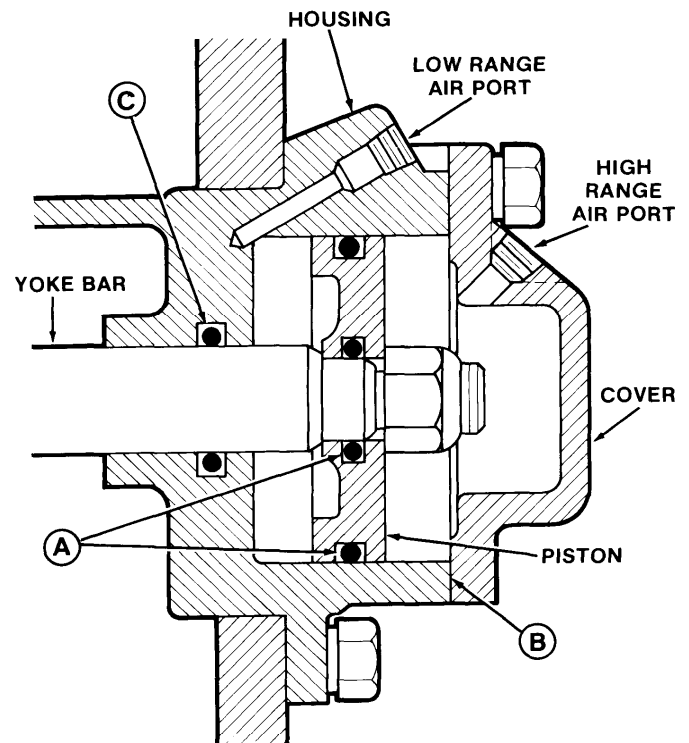

RANGE CYLINDER ASSEMBLY
ALL MODELS

AIR SYSTEM

AIR FILTER/REGULATOR ASSEMBLY

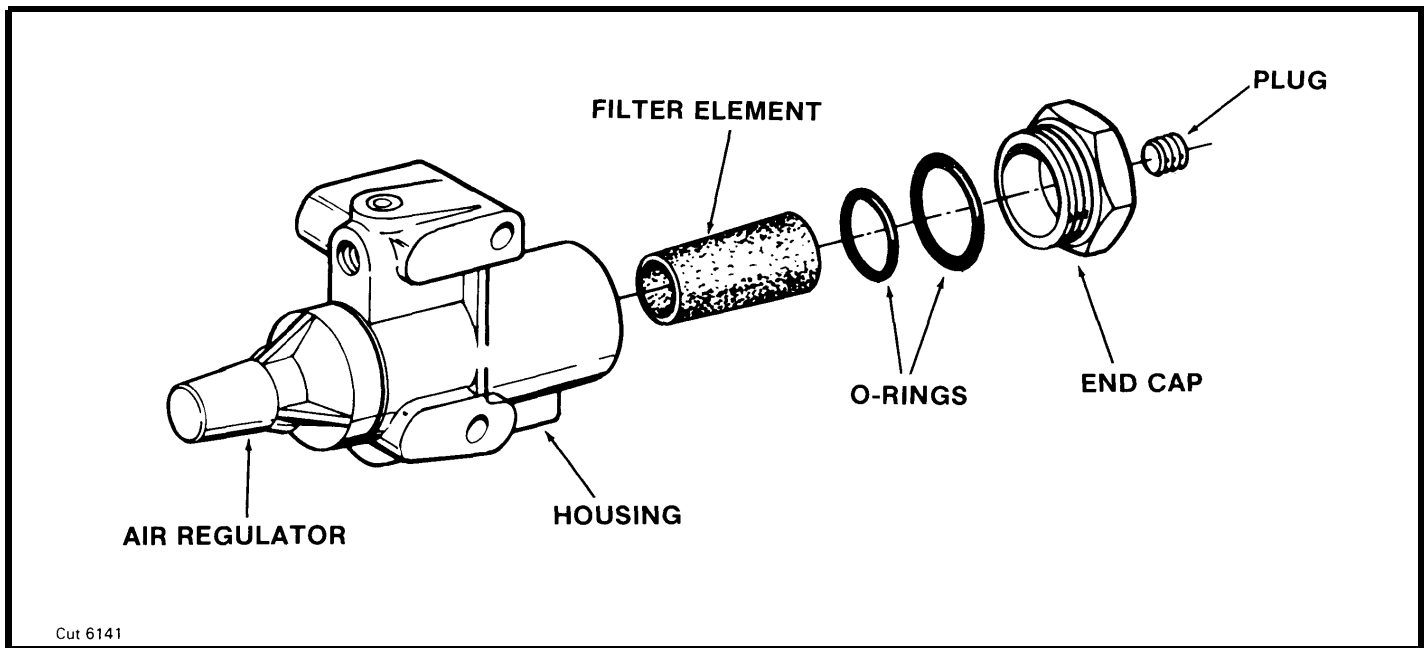

The air filter contains a replaceable filter element which can be removed by turning out the end cap. This element should be cleaned at each oil change, or more often under high humidity conditions. Replace if necessary.

SLAVE VALVES

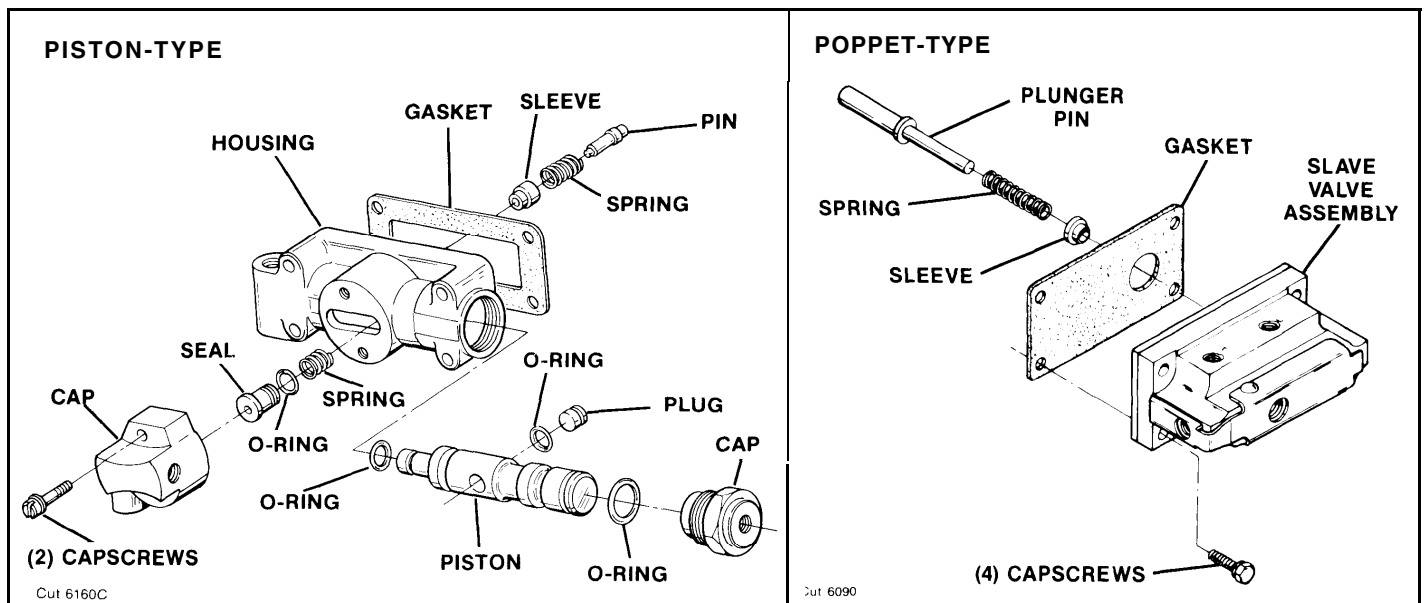

Refer to the drawing for disassembly and reassembly of the piston-type slave valve assembly. **Should the poppet-type slave valve assembly prove to be defective, replace the complete assembly, as it is non-serviceable.** The actuating components used with these valve assemblies are non-interchangeable. Failure to use the correct plunger pin, spring and alignment sleeve during installation on the transmission will cause hard shifting in Low Range gears.

AIR SYSTEM

RANGE CONTROL VALVE

NOTE: This valve provides range selection ONLY. When equipped on LL Models, the dash-mounted Deep Reduction Valve is required to provide deep reduction selections.

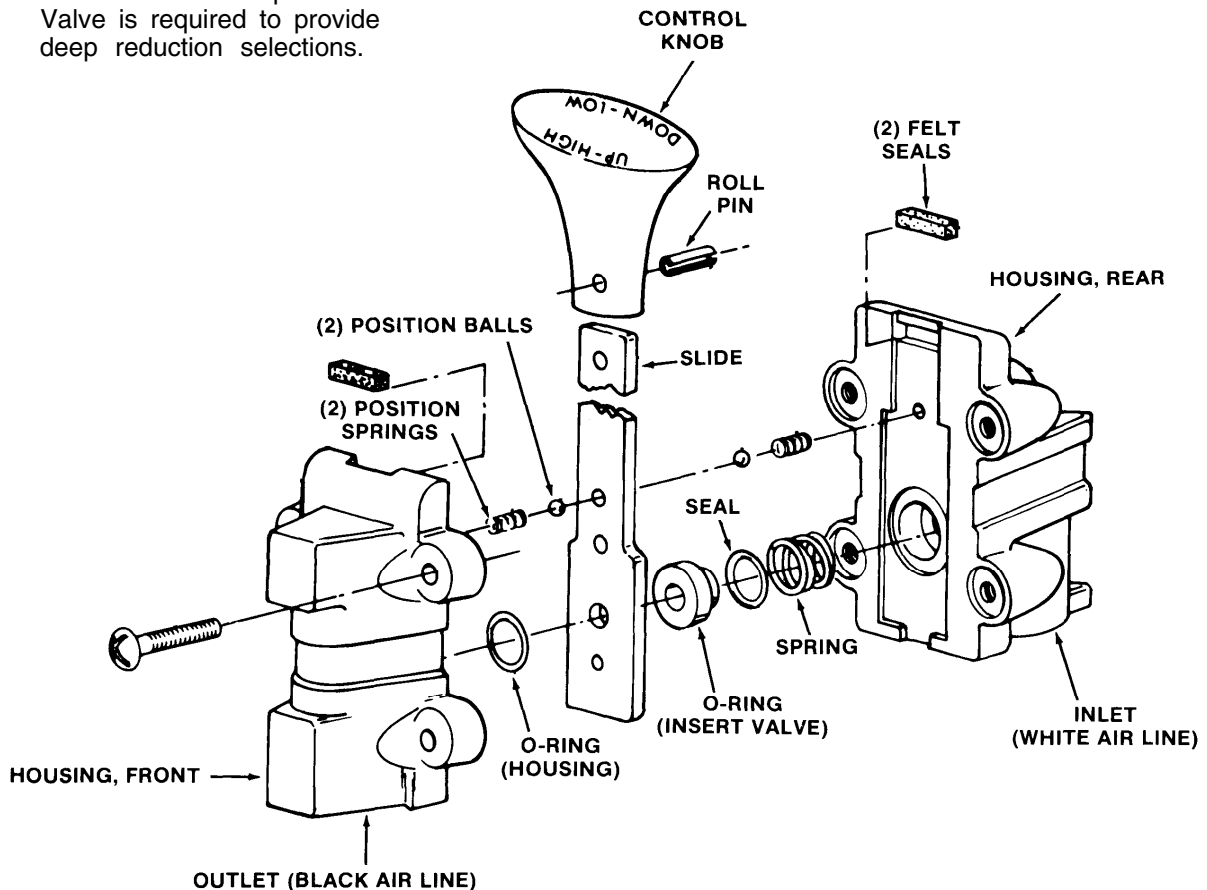

Cut 6155

Removal and Disassembly

1. Disconnect the air lines and loosen clamp securing the valve to gear shift lever. Remove valve.
2. Remove the four screws to separate the front and rear housings and remove the slide and two sets of position springs and balls.
3. Remove the seal, insert valve O-ring and spring from rear housing.
4. If necessary, remove the two felt seals. Punch out the roll pin to remove the control knob from slide.

Reassembly and Installation

1. Refer to the drawing for proper reassembly. Use a VERY SMALL amount of silicone lubricant on the O-rings to avoid clogging ports. A small amount of grease on the position springs and balls will help to hold them in place during reassembly.
2. Install the air lines with their sheathing and O-rings on the gear shift lever.
3. Secure the valve on gear shift lever with mounting clamp. The control knob should face to the front and be approximately 6" below the centerline of ball grip.
4. Attach the air lines.

AIR SYSTEM

MASTER CONTROL VALVE A-5010

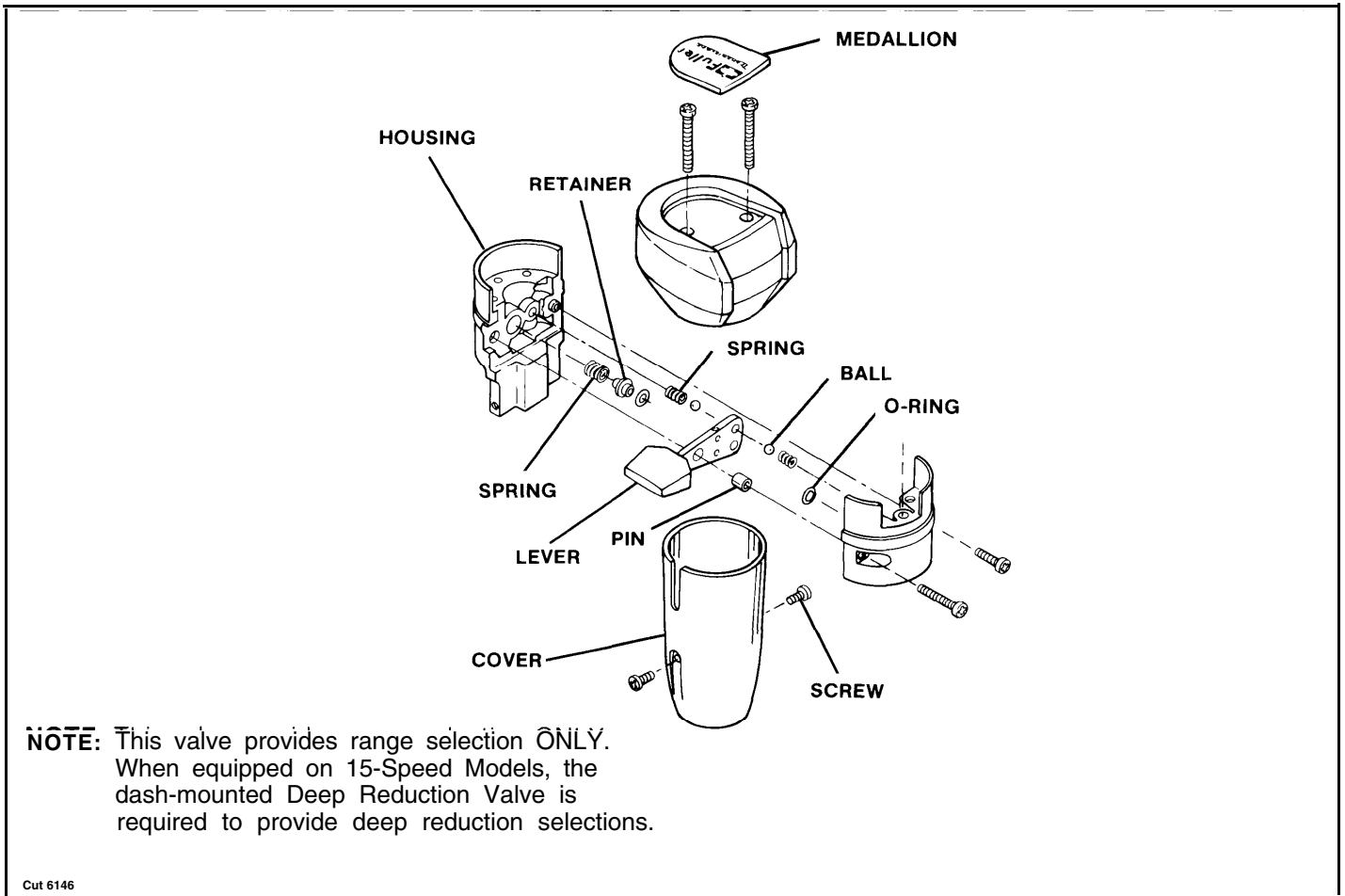

Removal and Disassembly

1. Remove two screws holding bottom cover to valve and slide cover down gear shift lever to expose air line fittings. Disconnect air lines.
2. Loosen jam nut and turn control valve from gear shift lever.
3. Pry medallion from recess in top cover.
4. Turn out the two screws to remove the top cover from valve housing.
5. Turn out the two screws in side of valve housing to separate the housing.
6. Remove the Range Preelection Lever from left housing and the position balls and guide from lever.
7. If necessary, remove spring and O-ring from bores in left housing.
8. If necessary, remove springs, O-ring and sleeve from bores in right housing.

Reassembly and Installation

1. Refer to the drawing for proper reassembly. Use a **VERY SMALL** amount of silicone lubricant on the O-rings to avoid clogging ports. A small amount of grease on the position springs and balls will help to hold them in place during reassembly.
2. Reinstall control valve on gear shift lever and tighten jam nut.
3. Attach air lines and reinstall bottom cover.

AIR SYSTEM

DEEP REDUCTION AIR SYSTEM: LOW-LOW MODELS ONLY

Operation

In addition to the various components of the Range Shift Air System, the Deep Reduction Air System utilizes a reduction cylinder and a separate dash-mounted Deep Reduction Valve OR the Master Control Valve A-5015.

CONSTANT AIR from the air filter/regulator assembly is supplied to the reduction cylinder at the port on right side of cylinder cover. See Air System Schematics.

With the Deep Reduction lever in the "OUT" position, the valve is OPENED and AIR is supplied to the Center Port of cylinder cover, moving the reduction piston forward to disengage deep reduction gearing. With the lever moved to the "IN" position, the valve is CLOSED and NO AIR is supplied to the Center Port. CONSTANT AIR from the air filter/regulator assembly moves the reduction piston rearward to engage reduction gearing.

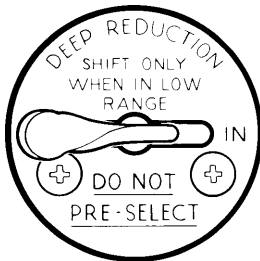

Lever to "OUT"
(Valve OPENED)

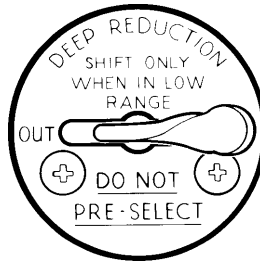

Lever to "IN"
(Valve CLOSED)

For models equipped with the Master Control Valve A-5015, AIR is supplied to the built-in deep reduction valve ONLY WHILE IN LOW RANGE from tee fitting at the Low Range or "L" Port of slave valve. The insert valve (see Page 33) MUST be installed in cylinder cover to provide the proper air flow needed to move the reduction piston in the cylinder. See schematic provided on Page 31.

NOTE: The insert valve is NOT USED in the reduction cylinder cover of models equipped with the Deep Reduction Valve.

With the Deep Reduction Button in the REARWARD position, the "SP" Port of control valve is CLOSED and NO AIR is supplied to the Center Port of cylinder cover.

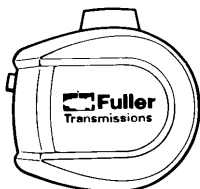

Button REARWARD
(“SP” Port CLOSED)

WHILE IN LOW RANGE, the button can be moved FORWARD to operate in DEEP REDUCTION. The "SP" Port of valve is OPENED when deep reduction selection is made, supplying AIR to the Center Port of cylinder cover.

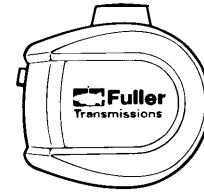

Button FORWARD
(“SP” Port OPENED)

NOTE: WHILE IN HIGH RANGE, the mechanical interlock of Master Control Valve prevents movement of Deep Reduction Button to the FORWARD position.

Troubleshooting

If the transmission fails to shift or shifts too slowly to or from DEEP REDUCTION, the fault may be in the Deep Reduction Air System or related components of the Range Shift Air System.

To locate the trouble, the following checks should be made with normal vehicle air pressure supplied to the system, but with the engine off. See CAUTION, Page 24.

NOTE: It is assumed that correct PSI readings were obtained from the air filter/regulator and all air lines have been checked for leaks.

For Models Equipped with the Deep Reduction Valve . . .

1. Air Supply (See Air System Schematics.)

With the gear shift lever in neutral, loosen the connection at the INLET (End Port) or Deep Reduction Valve until it can be determined that CONSTANT AIR is supplied to valve. Reconnect air line.

If there is NO AIR, check for a restriction in line between the Deep Reduction Valve and slave valve, making sure this line is connected to tee fitting at the Supply or "S" Port of slave valve.

AIR SYSTEM

2. Deep Reduction Valve (See Air System Schematics.)

With the gear shift lever in neutral, disconnect the air line leads from OUTLET of Deep Reduction Valve.

- A. WHILE IN LOW RANGE, move the Deep Reduction Valve Lever to the "IN" position. There should be NO AIR from disconnected line.
- B. Move the valve lever to the "OUT" position. There should now be CONSTANT AIR flowing from disconnected line. Return the valve lever to the "IN" position to shut off air flow and reconnect air line.

3. Reduction Cylinder (Refer to the following Illustration.)

If any of the seals in the reduction cylinder assembly are defective, the deep reduction shift will be affected. The degree of air lost will govern the degree of failure, from slow shifting to complete shift failure.

- A. Leak at O-ring A results in a slow shift to engage deep reduction gearing; pressurizing of transmission case; deep reduction gearing can be disengaged.
- B. Leak at O-ring B results in slow shifting or complete failure to engage and disengage deep reduction gearing; steady flow of air from exhaust port of Deep Reduction Valve when lever is in the "IN" position.
- C. Leak at gasket C results in a slow shift to disengage deep reduction gearing; steady flow of air to atmosphere.

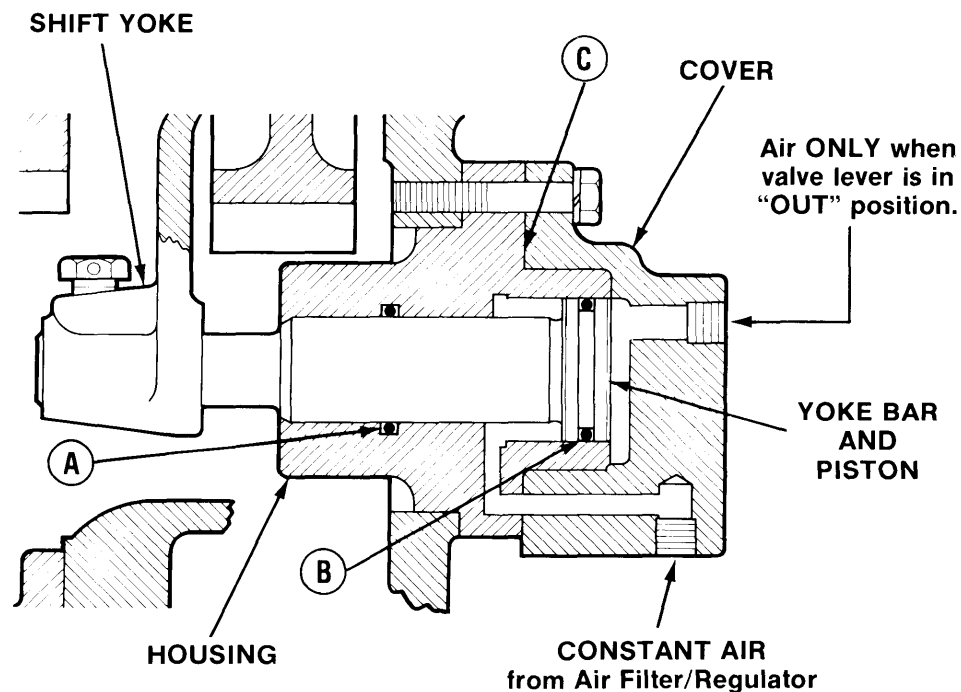

Cut 7440

REDUCTION CYLINDER ASSEMBLY
(Models equipped with Deep Reduction Valve ONLY.)

AIR SYSTEM

For Models Equipped with the Master Control Valve A-5015 . . .

- 1. Air Supply (See schematic below.)**
With the gear shift lever in neutral, select LOW RANGE and loosen the connection at the "H" Port of control valve until it can be determined that AIR is supplied to valve. Reconnect air line. If there is

NO AIR, check for a restriction in the 1/8" O.D. air line between the control valve and slave valve, making sure this line is connected to tee fitting at the Low Range or "L" Port of slave valve.

NOTE: Arrows are provided in this schematic to note direction of air flow through PRESSURIZED LINES SHOWN AS SHADED AREA ONLY.

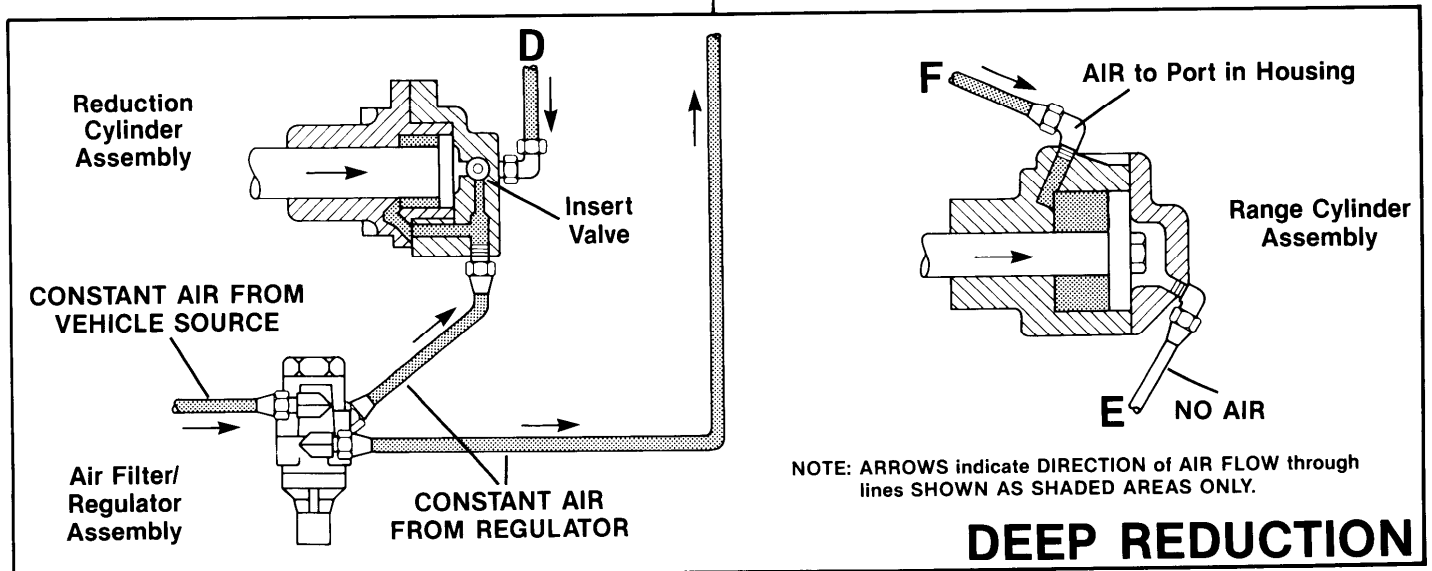
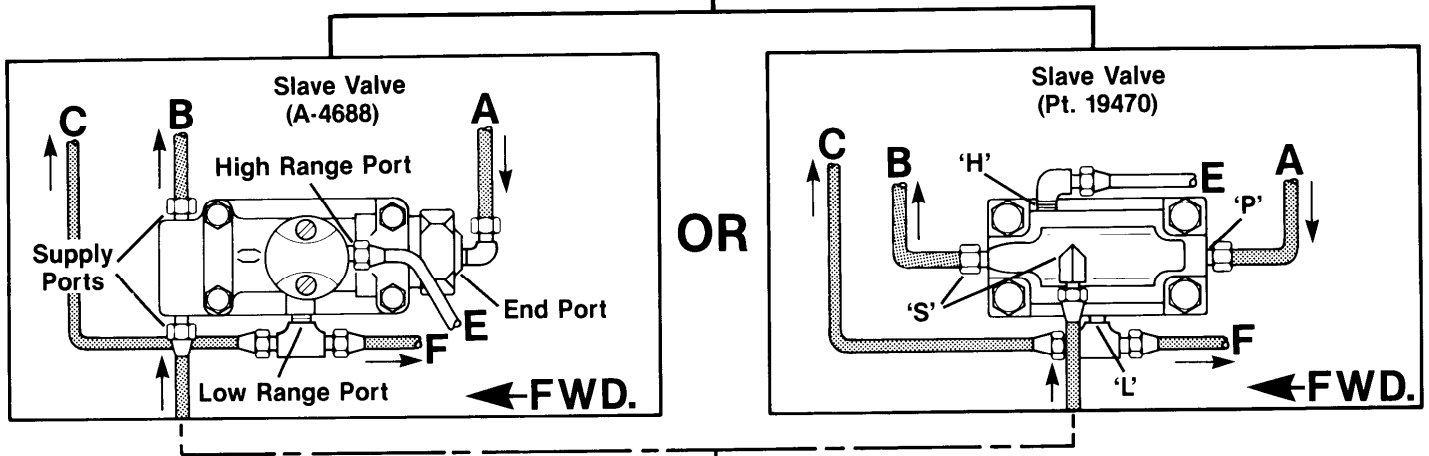
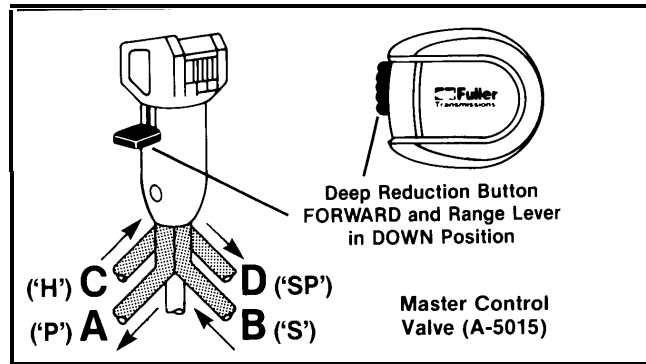

AIR SYSTEM

2. **Master Control Valve (See Page 34 and schematic on preceding page.)**
With the gear shift lever in neutral, disconnect the 1/8" O.D. air line at the Center Port of reduction cylinder cover, making sure this line leads from the "SP" Port of control valve.
- A. WHILE IN LOW RANGE, move the Deep Reduction Button FORWARD. There should be AIR flowing from disconnected line. Move the button REARWARD to shut off air flow and reconnect air line.
 - B. If the preceding conditions did not exist, the control valve is defective, or there is a restriction in the air lines.

3. **Reduction Cylinder (Refer to the following illustration.)**
If any of the seals in the reduction cylinder assembly are defective, the deep reduction shift will be affected. The degree of air lost will govern the degree of failure, from slow shifting to complete shift failure.

- A. Leak at O-ring A results in a slow shift to engage deep reduction gearing; pressurizing of transmission case; deep reduction gearing can be disengaged.
- B. Leak at O-ring B results in slow shifting or complete failure to engage and disengage deep reduction gearing; steady flow of air from exhaust port of control valve and/or cylinder cover when Deep Reduction Button is in the FORWARD position.
- C. Leak at gasket C results in a slow shift to disengage deep reduction gearing; steady flow of air to atmosphere.

4. **Insert Valve (See next page.)**
Any constant flow of air from exhaust port of cylinder cover usually indicates a faulty insert valve. Exhaust should occur ONLY BRIEFLY when Deep Reduction Button is moved FORWARD WHILE IN LOW RANGE.

A faulty insert valve, leaking at the O-rings of valve O.D. or from inner seals, will result in shift failure. Two indications of defective O-rings or seals are:

- A. CONSTANT AIR flowing from exhaust port of cylinder cover.
- B. CONSTANT AIR flowing from exhaust port "E" of control valve WHILE DEEP REDUCTION BUTTON IS REARWARD (providing the control valve is operating properly).

The three O-rings in position on valve O.D can be replaced. However, if an inner seal is damaged, the complete assembly MUST be replaced.

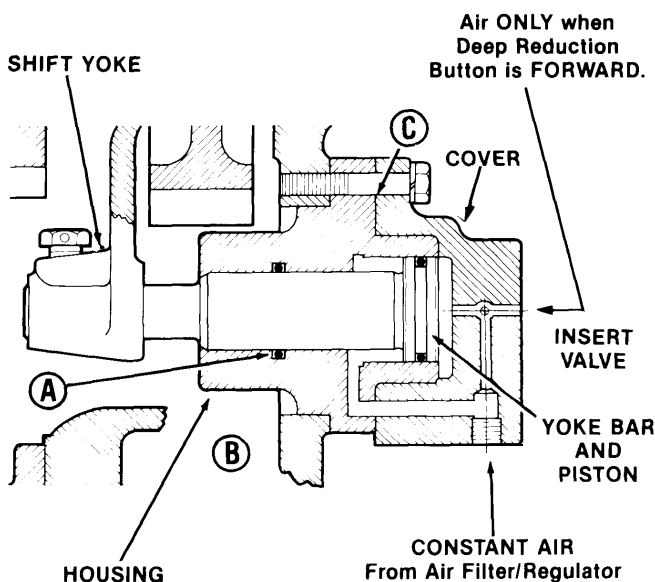

Cut 7441

REDUCTION CYLINDER ASSEMBLY
(Models equipped with Master Control A-5015 ONLY.)

AIR SYSTEM

Insert Valve: LL Models Equipped with Master Control Valve A-5015

The insert valve is a self-contained 1-3/16" valve assembly located in the reduction cylinder cover. It CANNOT be disassembled except for the three O-RINGS ON outer diameter. The O-rings provide a stationary seal and do not move in cylinder.

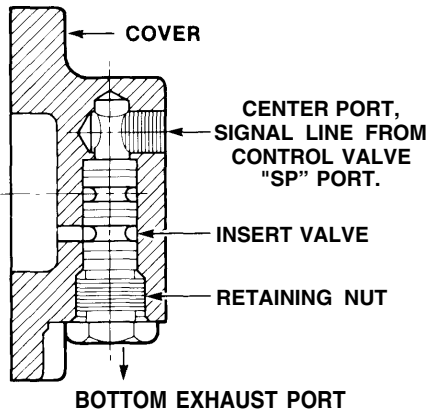

Cut 7450

When installing the insert valve in bottom bore of cover, apply Fuller #71206 silicone lubricant or its equivalent to O-rings and cylinder walls. Install valve in bore with flat surface to the inside. When installing the special valve retaining nut, apply Fuller #71204 adhesive/sealant or its equivalent to threads and tighten. See TORQUE RECOMMENDATIONS.

Travel of the small insert valve piston is only 3/16". As shown in the illustrations below, when NO AIR is applied to the top side of valve piston, CONSTANT AIR supplied from the regulator passes freely through the insert valve and to the back side of cylinder piston, moving the yoke bar forward to disengage deep reduction gearing (LOW RANGE AND HIGH RANGE). When AIR is supplied to the top side of valve piston through signal line, the piston moves down to cutoff air supplied to the back side of cylinder piston. This air is exhausted out bottom port of cover when CONSTANT AIR supplied from the regulator is directed to the front side of cylinder piston, moving the yoke bar rearward to engage deep reduction gearing (LO/LO).

LO/LO

LOW RANGE AND HIGH RANGE

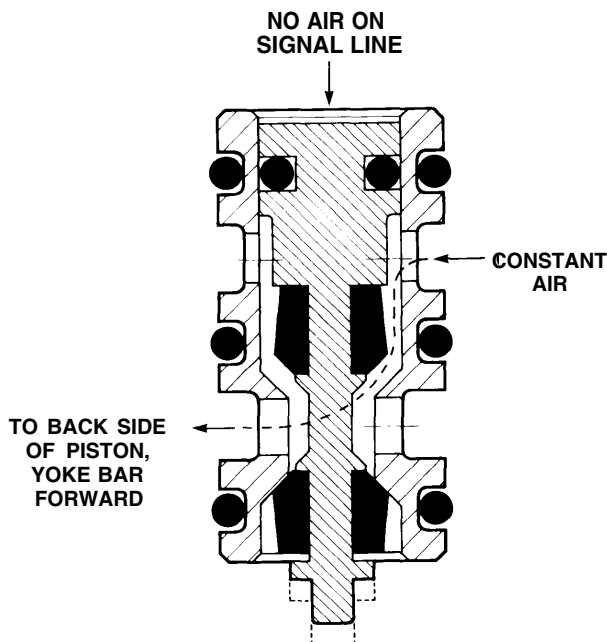

Cut 7450A

AIR APPLIED THROUGH SIGNAL LINE PUSHES INSERT VALVE PISTON DOWN

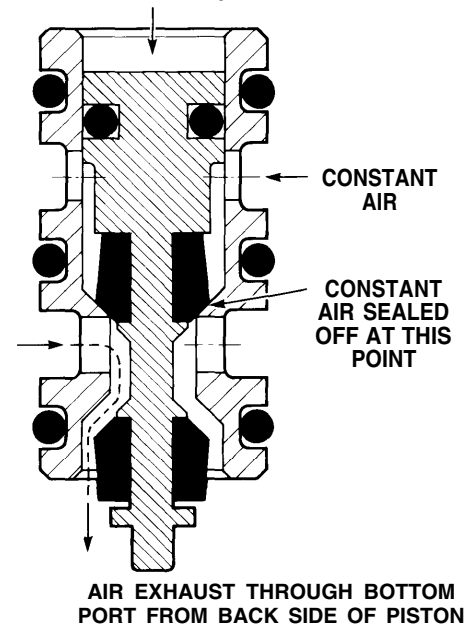

AIR SYSTEM

MASTER CONTROL VALVE A-5015

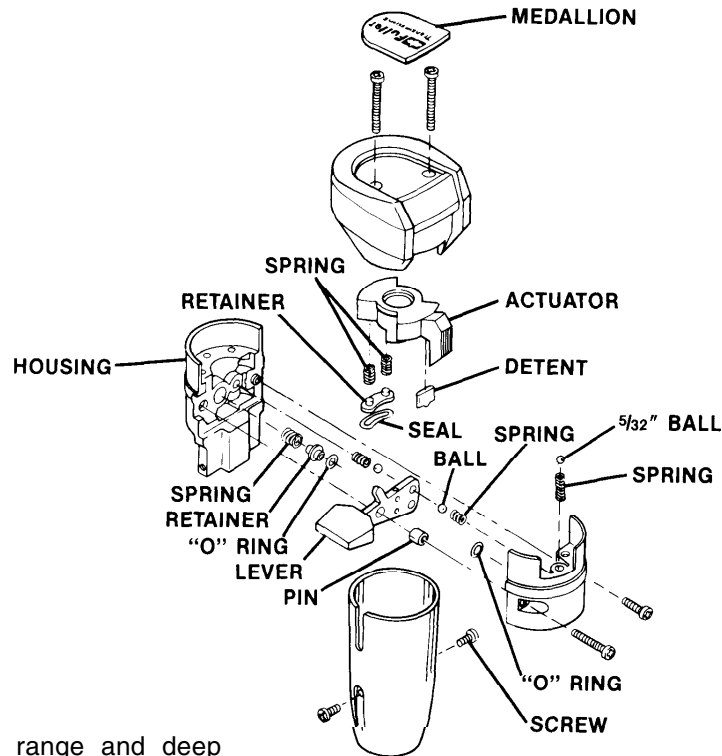

NOTE: This valve provides BOTH range and deep reduction selection, replacing the need for separate units (Range Control Valve A-3546 or Master Control Valve A-5010 with dash-mounted Deep Reduction Valve).

Removal and Disassembly

1. Remove two screws holding bottom cover to valve and slide cover down gearshift lever to expose air line fittings. Disconnect air lines.
2. Loosen jam nut and turn control valve from gear shift lever.
3. Pry medallion from recess in top cover.
4. Turn out the two screws to remove the top cover from valve housing,
5. Remove the actuator button from valve housing and the spring retainer, springs, seal and detent parts from actuator and/or valve housing.
6. Turn out the two screws in side of valve housing to separate the housing.
7. Remove the Range Preelection Lever from left housing and the position balls and guide from lever.
8. If necessary, remove springs, O-ring and retainer from bores in right housing.

Reassembly and Installation

1. Refer to the drawing for proper reassembly. Use a VERY SMALL amount of silicone lubricant on the O-rings to avoid clogging ports. A small amount of grease on the position springs and balls will help to hold them in place during reassembly.
2. Reinstall control valve on gear shift lever and tighten jam nut.
3. Attach air lines and reinstall bottom cover.

7L: 8: 9: and 10 Speed (2-Speed Auxiliary)

Range—LO

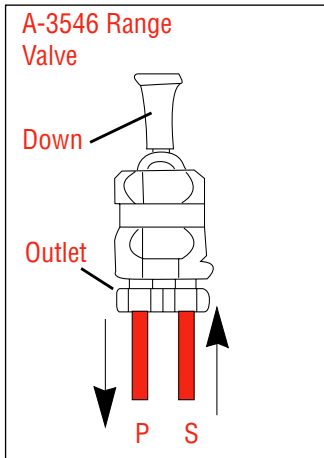

OR

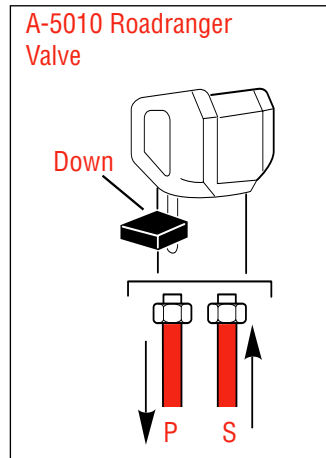

Slave Valve Identification

A-4688 Valve

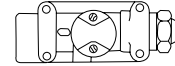

A-5000 Valve

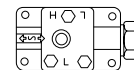

19470 Valve

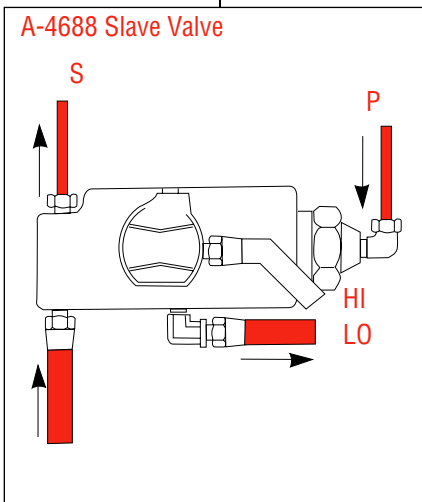
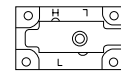

OR

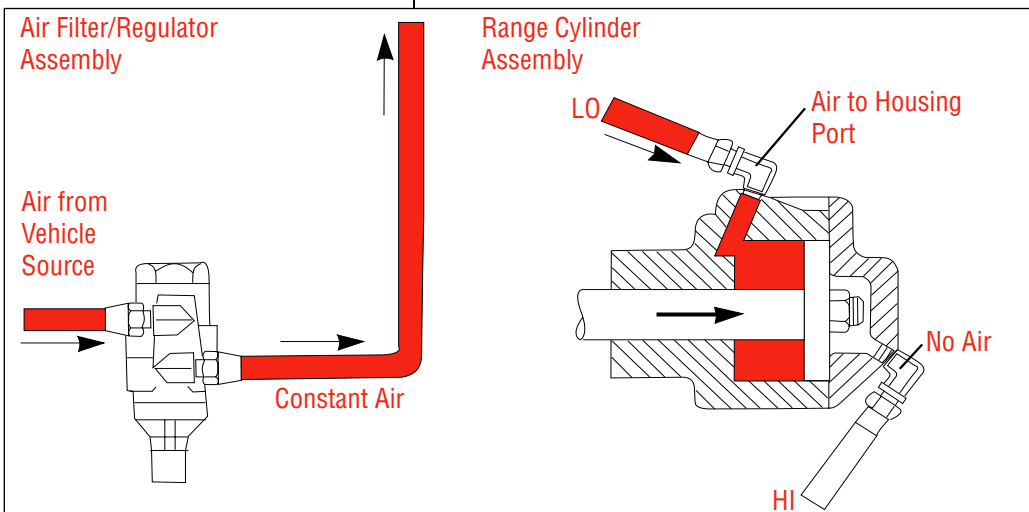
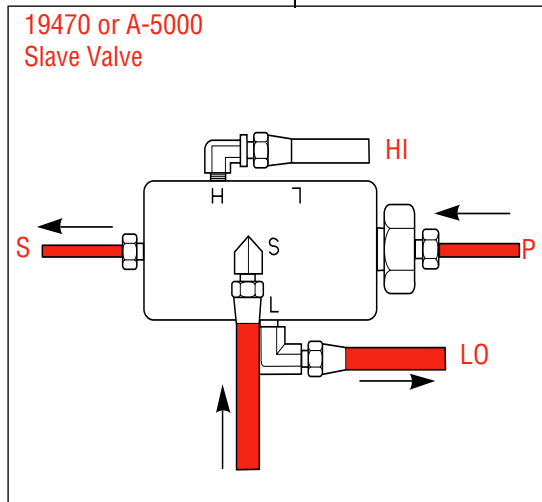

Schematic

For all questions concerning removal and replacement, refer to Eaton Service and Parts Literature.

7L: 8: 9: and 10 Speed (2-Speed Auxiliary)

Range—HI

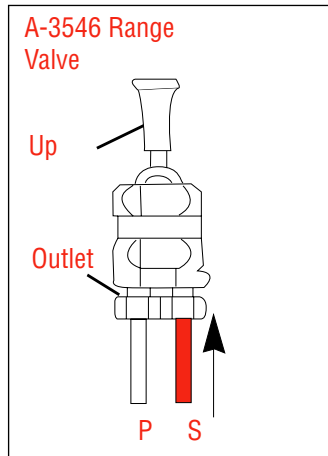

OR

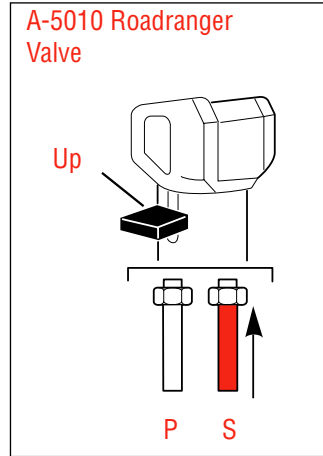

Slave Valve Identification

A-4688 Valve

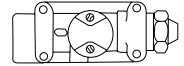

A-5000 Valve

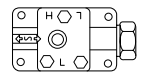

19470 Valve

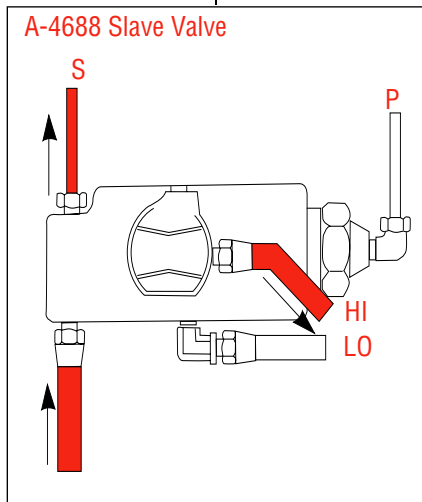
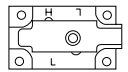

OR

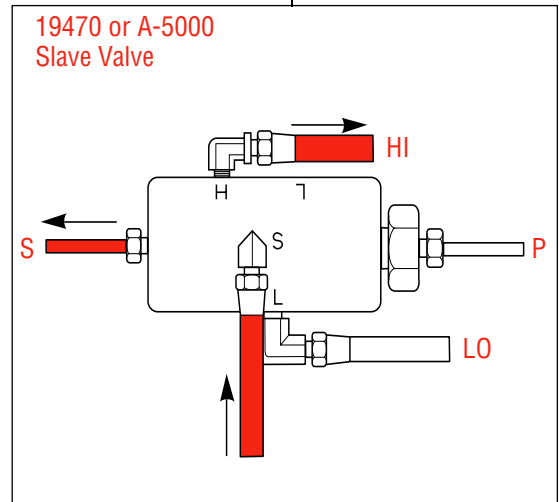

Schematic

For all questions concerning removal and replacement, refer to Eaton Service and Parts Literature.

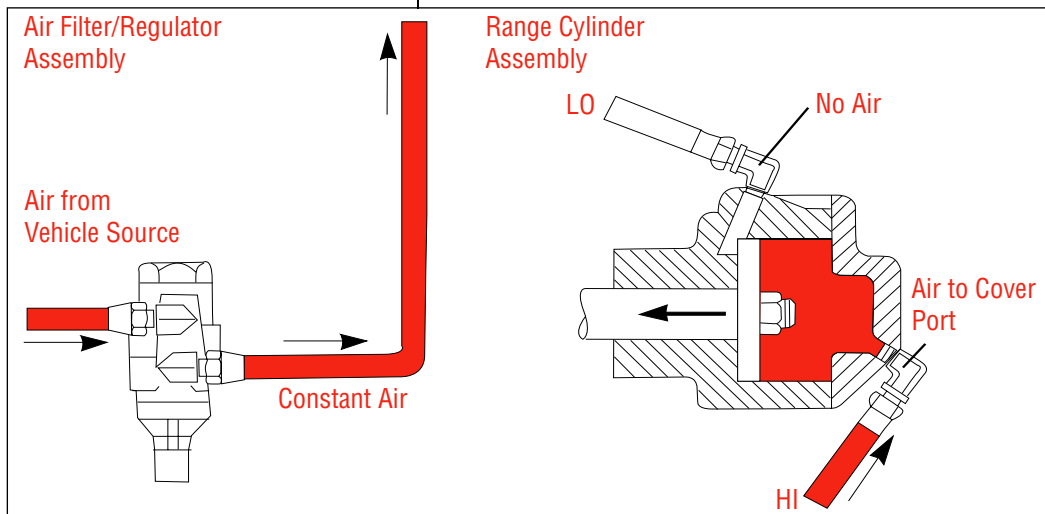

RT, RTO, & RTX XX607LL: XX608LL: and XX615 Models

Deep Reduction

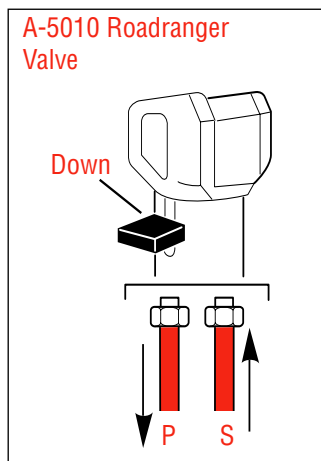
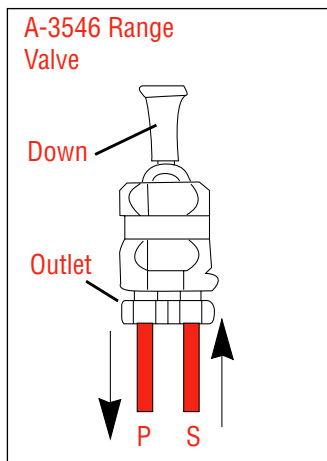

Slave Valve Identification

A-4688 Valve

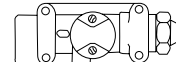

A-5000 Valve

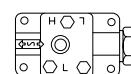

19470 Valve

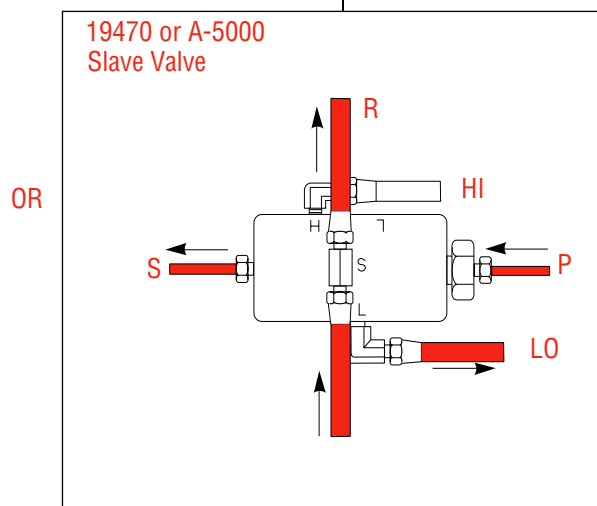
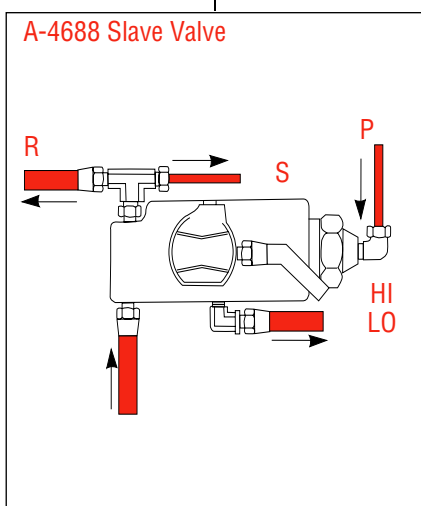
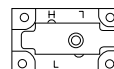

Schematic

For all questions concerning removal and replacement, refer to Eaton Service and Parts Literature.

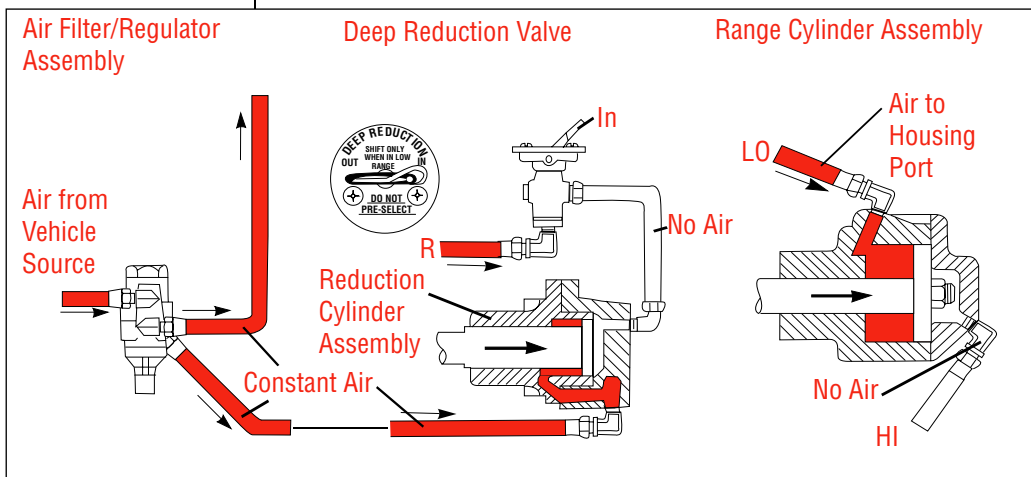

RT, RTO, & RTX XX607LL: XX608LL: and XX615 Models

Range—LO

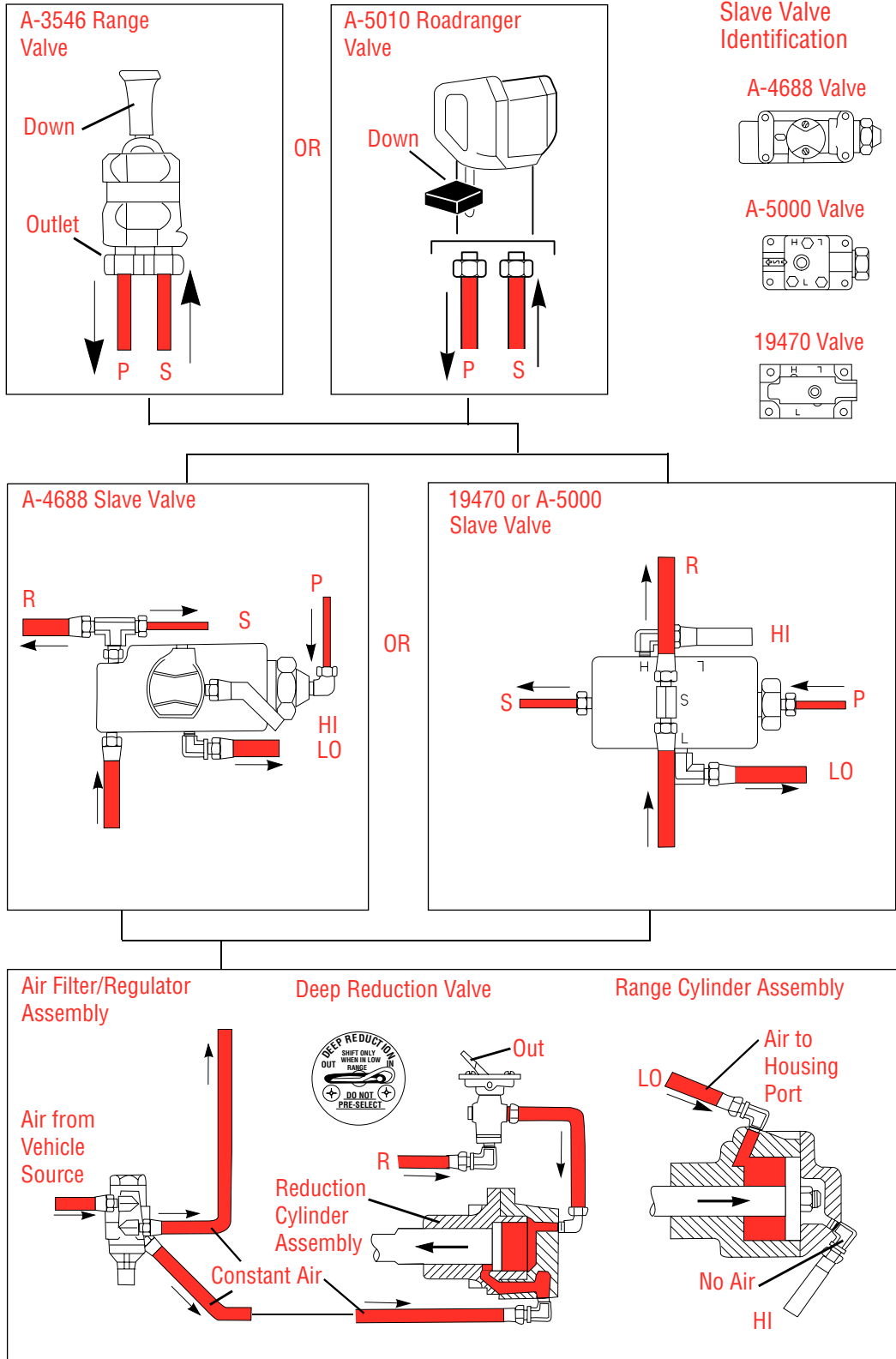

Schematic

For all questions concerning removal and replacement, refer to Eaton Service and Parts Literature.

RT, RTO, & RTX XX607LL: XX608LL: and XX615 Models

Range—HI

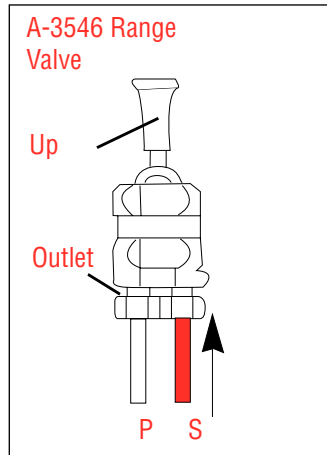

OR

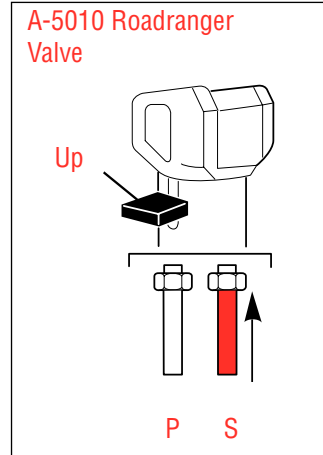

Slave Valve Identification

A-4688 Valve

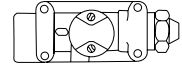

A-5000 Valve

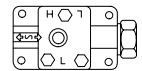

19470 Valve

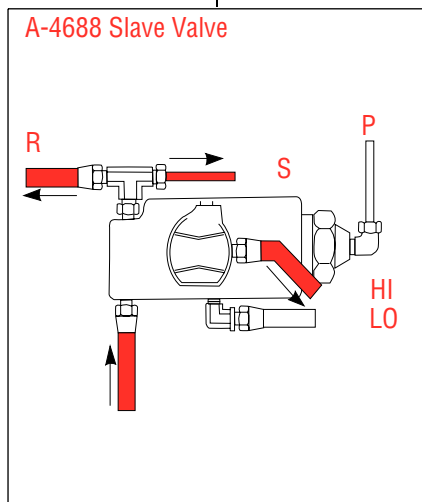
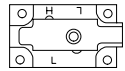

OR

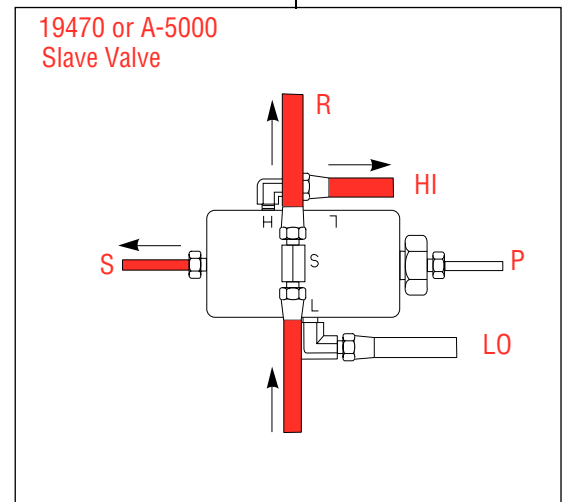

Schematic

For all questions concerning removal and replacement, refer to Eaton Service and Parts Literature.

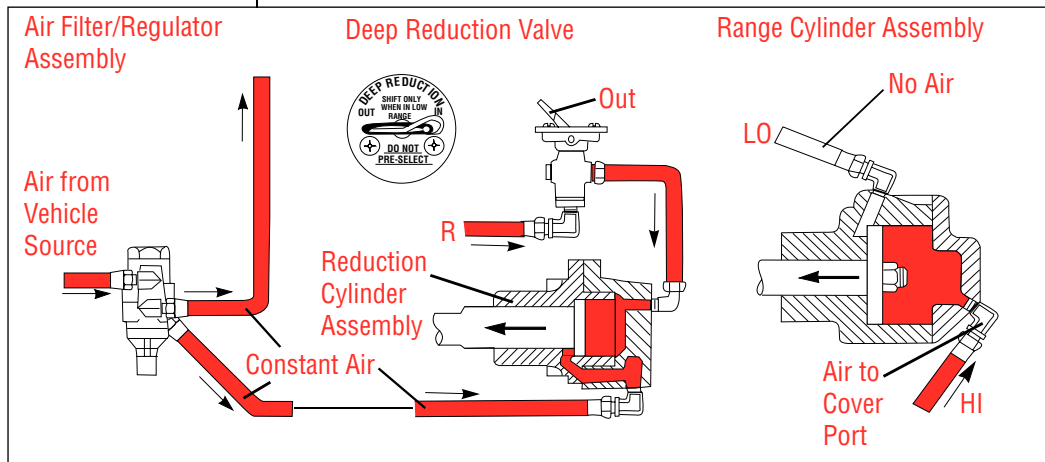

DISASSEMBLY AND REASSEMBLY SHIFTING CONTROLS

RANGE SHIFT AIR SYSTEM

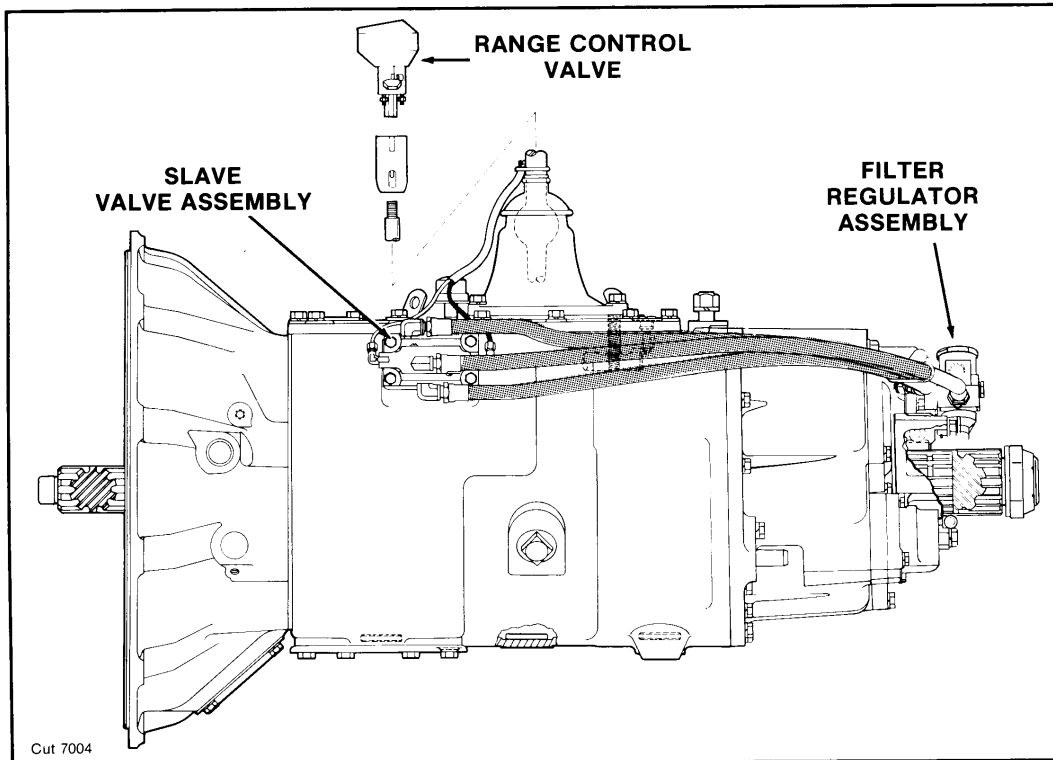

A. To Remove the Range Shift Control Valve. (RTO-11607L)

NOTE: The example shown in this sequence uses an A-5010 master control valve and a #19470 slave valve. Disassembly is similar for units equipped with different control and slave valve combinations.

disconnect the nylon air lines at the master control valve.



1. Slide the shroud off the master control and



2. Disconnect the two nylon air lines at slave valve on transmission.

DISASSEMBLY AND REASSEMBLY SHIFTING CONTROLS



3. Remove the master control valve, shroud and nylon air lines from the shift lever.

B. To Remove the Air Regulator and Filter Assembly

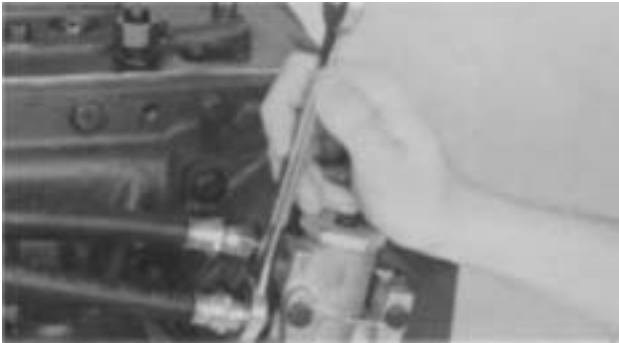

1. Disconnect and remove the air line between the slave valve and air regulator.
2. Remove street ell and reducer from regulator if necessary.



3. Turn out cap screws and remove the air regulator and filter assembly from transmission.

C. To Remove the Slave Valve Assembly



1. Remove the two air lines between the slave valve and range cylinder.



2. Turn out the four cap screws and remove the slave valve from the transmission. Remove the sleeve from the slave valve.

DISASSEMBLY AND REASSEMBLY SHIFTING CONTROLS



3. If necessary, remove fittings from slave valves.



4. Remove the actuating spring and pin from bore in transmission.

DISASSEMBLY AND REASSEMBLY SHIFTING CONTROLS

RANGE SHIFT AIR SYSTEM

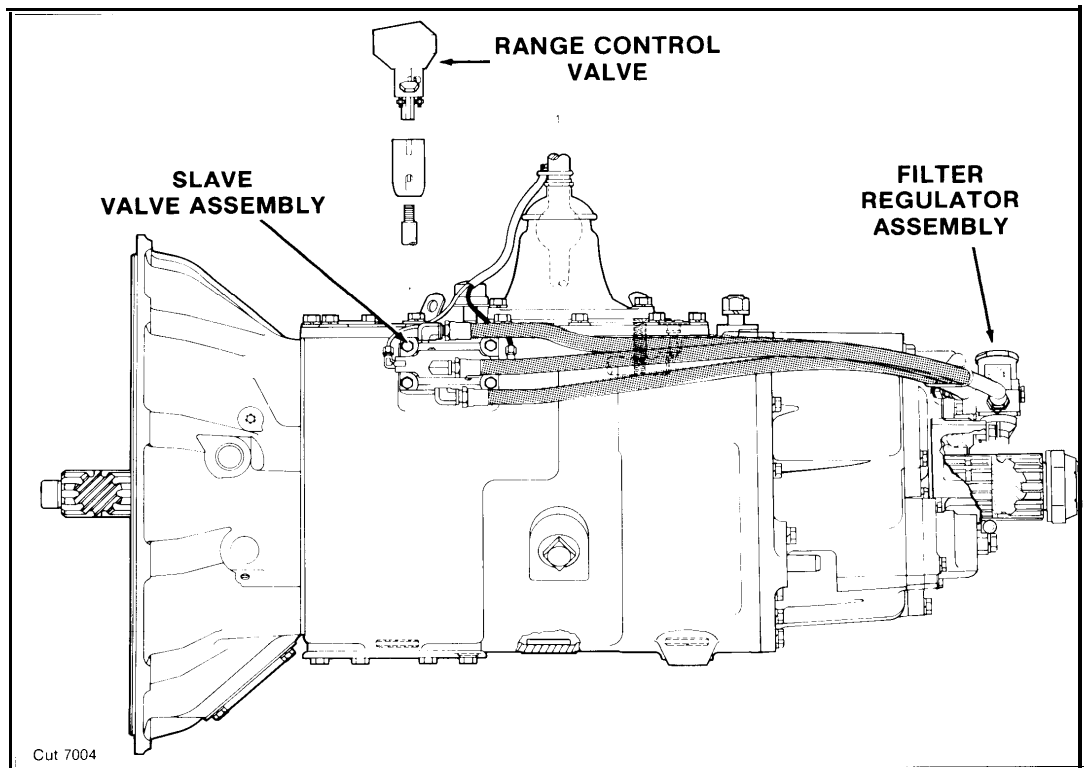

A. Remove the Range Shift Control Valve (RTO-11607LL)

NOTE: The example shown in this sequence uses an A-5015 Master Control Valve, a Deep Reduction Cylinder and an A-4688 Slave Valve.

master control and disconnect the nylon air lines at the master control valve.



1. Remove retaining screws, slide the shroud off the

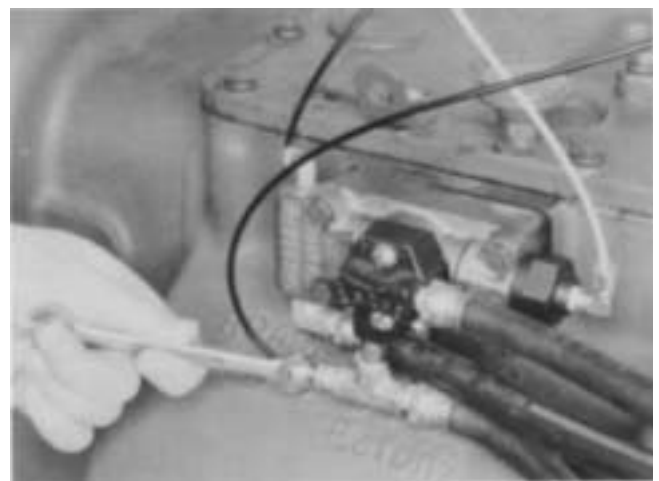

2. Disconnect the three nylon air lines at the slave valve.

DISASSEMBLY AND REASSEMBLY SHIFTING CONTROLS



3. Disconnect the nylon air line at the deep reduction cylinder.

B. To Remove Air Regulator and Filter Assembly

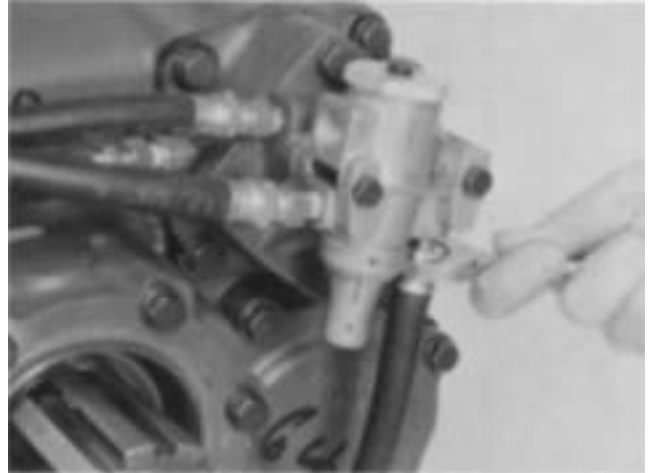

1. Remove the air line between the air regulator and the deep reduction cylinder.



4. Remove the master control valve, shroud and nylon air lines from the shift lever.

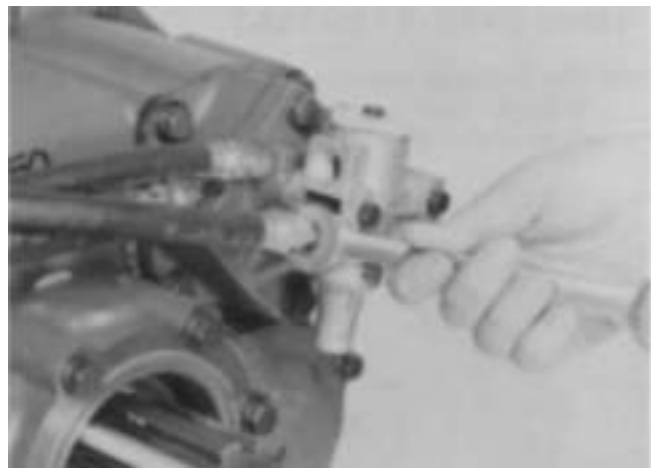

2. Remove the air line running from the air regulator to the slave valve at the regulator.

DISASSEMBLY AND REASSEMBLY SHIFTING CONTROLS

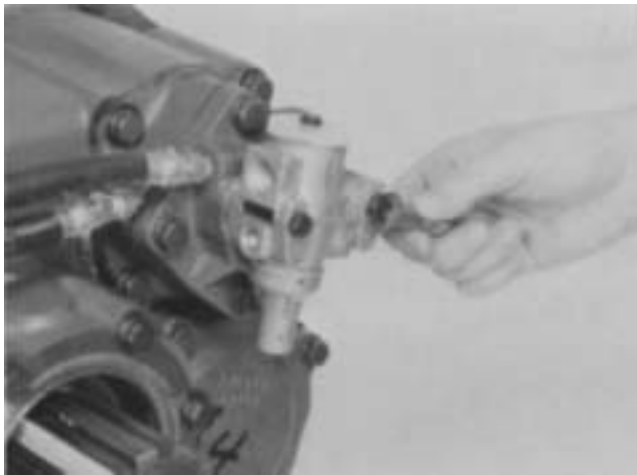

3. Turn out cap screws and remove the air regulator and filter assembly from transmission.



2. Disconnect the two air lines running between the slave valve and the range cylinder, at the range cylinder.

C. To Remove the Slave Valve



1. Remove the hose clamp holding the air lines to the auxiliary.



3. Turn out the four cap screws and remove the slave valve from the transmission.

DISASSEMBLY AND REASSEMBLY SHIFTING CONTROLS



4. Remove the hat type sleeve from the bore in the slave valve.



5. Remove the actuating spring and pin from bore in transmission.

DISASSEMBLY AND REASSEMBLY SHIFTING CONTROLS

GEAR SHIFT LEVER HOUSING

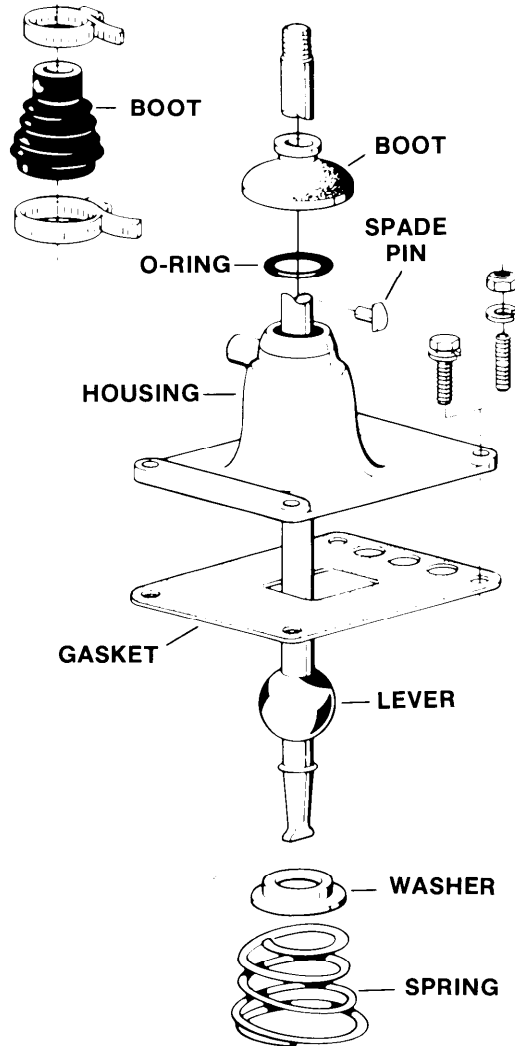

DISASSEMBLY AND REASSEMBLY SHIFTING CONTROLS

A. Removal and Disassembly



1. Turn out the capscrews, jar lightly to break the gasket seal and remove the gear shift lever housing from the shift bar housing.



2. Secure the housing in a vise and use a large screwdriver to twist between the spring and side of the housing, forcing the spring from under the three lugs. Do one coil at a time. Remove the spring.
3. Remove the washer and gear shift lever.
4. Remove the spade pin from the bore in the housing. If necessary, remove the O-ring from the housing.

B. Reassembly and Installation

1. Install the spade pin in the bore in the housing. If previously removed, install the O-ring in the groove.
2. Install the gear shift lever in the housing, fitting the slot in the lever ball over the spade pin.
3. Place the tension spring washer over the lever ball with the dished side up.



4. Seat the tension spring under the lugs in the housing, seating one coil at a time. Use of a spring driving tool is recommended.

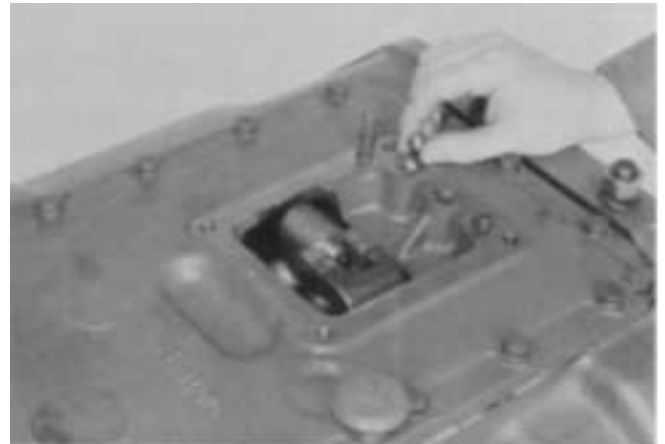

5. Make sure that the three tension springs and balls are in the shift bar housing bores and install the gear shift lever housing and gasket on the shift bar housing.

DISASSEMBLY AND REASSEMBLY SHIFTING CONTROLS

SHIFT BAR HOUSING ASSEMBLY

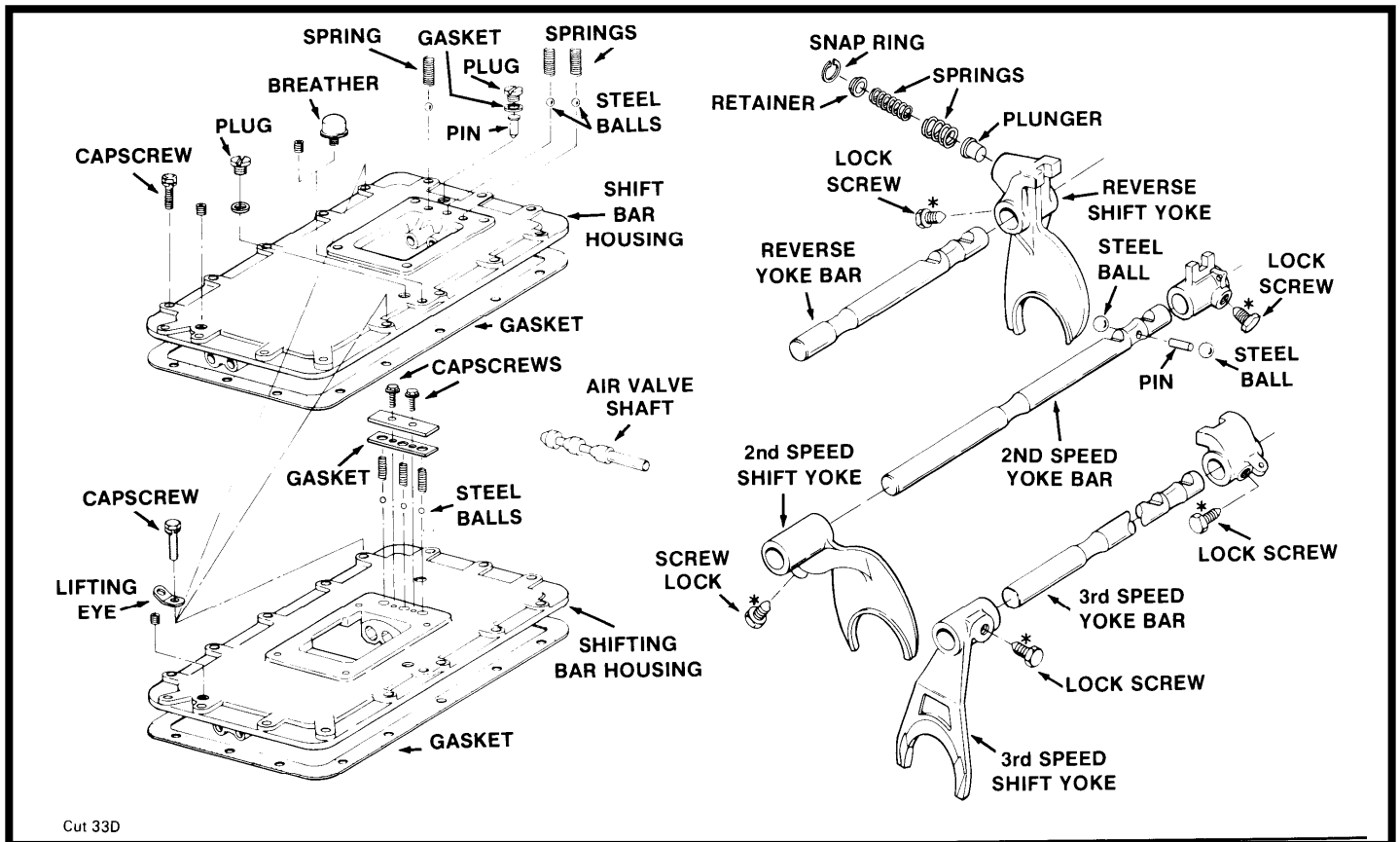

A. Removal and Disassembly Shift Bar Housing



1. Remove the cap screws from the shift bar housing.



2. Jar the housing to break the gasket seal, and lift the housing up and off.

DISASSEMBLY AND REASSEMBLY SHIFTING CONTROLS

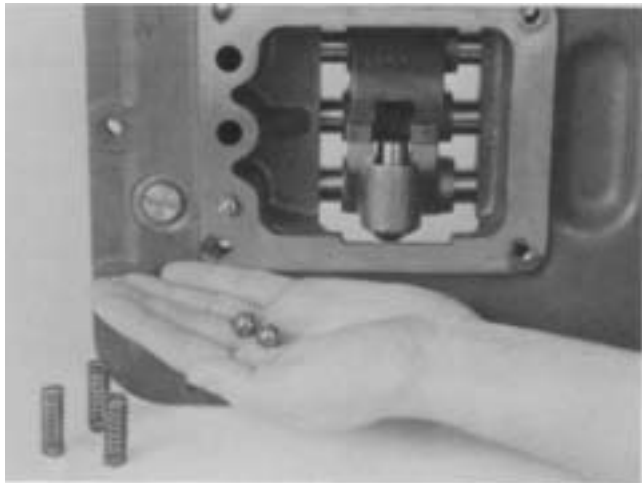

3. Tilt the housing, and remove the three tension balls and springs.

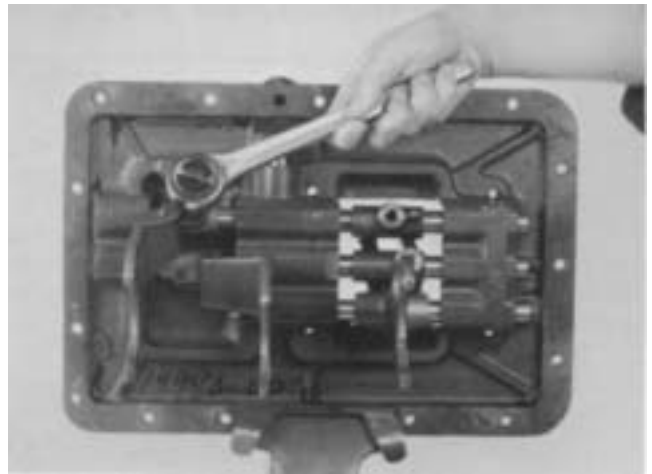

5. Remove the cap screws from all shift yokes and blocks.

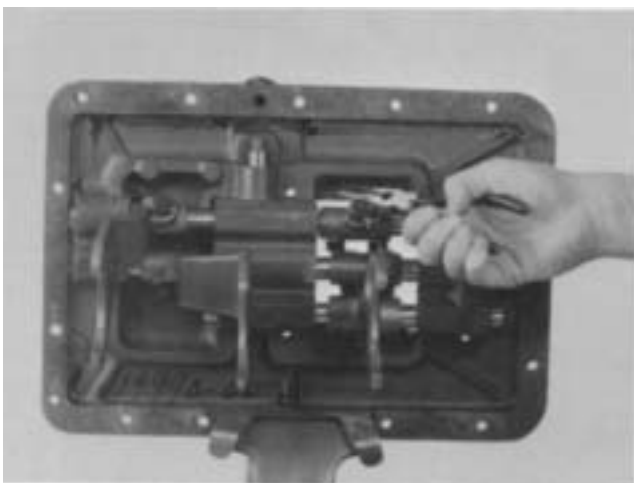

4. Place housing in a vice with plunger side up and cut lock wire from all cap screws.

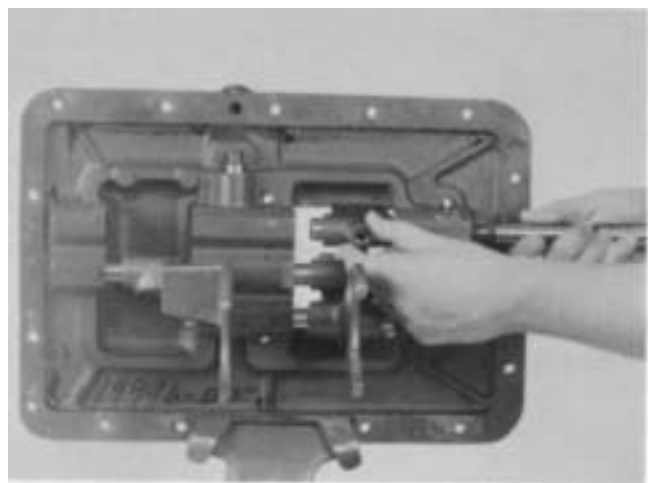

6. Slide the direct shift rail out of yokes and the housing.

NOTE: Rails not being removed must be in the neutral position.

DISASSEMBLY AND REASSEMBLY SHIFTING CONTROLS

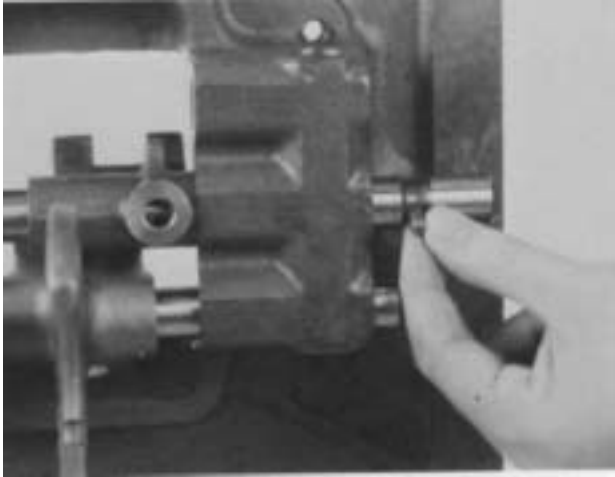

7. Remove center rail, yoke and block, being careful to remove the neutral interlock pin from the rail.

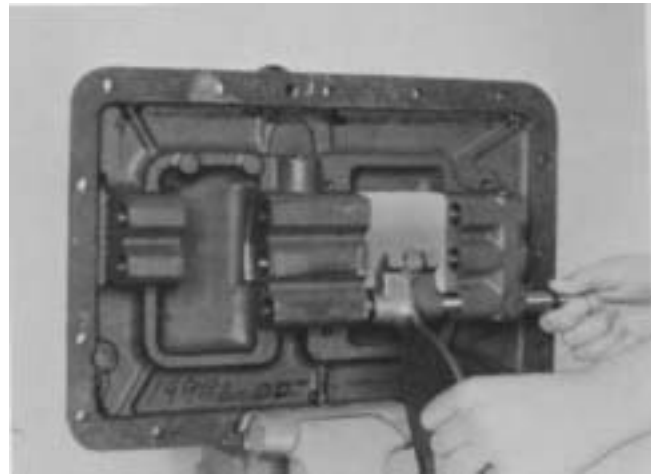

9. Remove reverse rail and yoke.

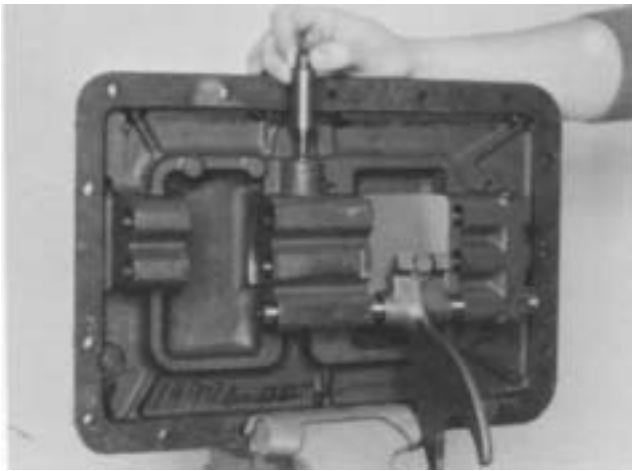

8. Remove air system interlock plunger.



10. Remove the two interlock balls from the front web.

DISASSEMBLY AND REASSEMBLY SHIFTING CONTROLS

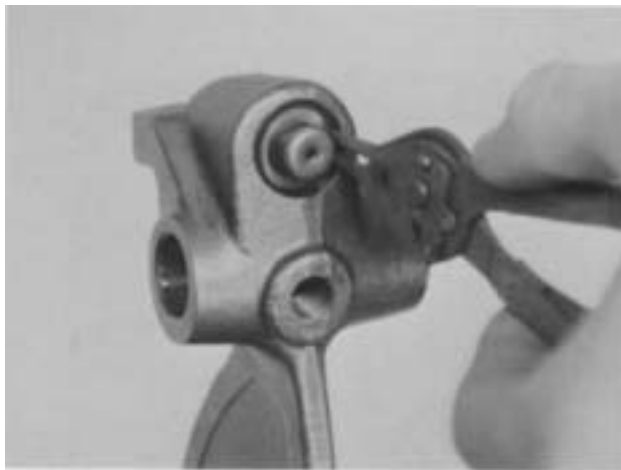

11. Clamp the reverse yoke in a soft jawed vice and remove the snap ring from the reverse yoke plunger.
12. Remove the retainer, springs and plunger from the bore.

DISASSEMBLY AND REASSEMBLY SHIFTING CONTROLS

SHIFT BAR HOUSING ASSEMBLY

A. To Reassemble Shift Bar Housing



1. Coat the reverse yoke plunger lightly with oil, and install in bore.



3. Install the hat shaped retainer in the bore with the crown to the outside.



2. Install the springs in the bore, with the smaller diameter spring inside the larger.

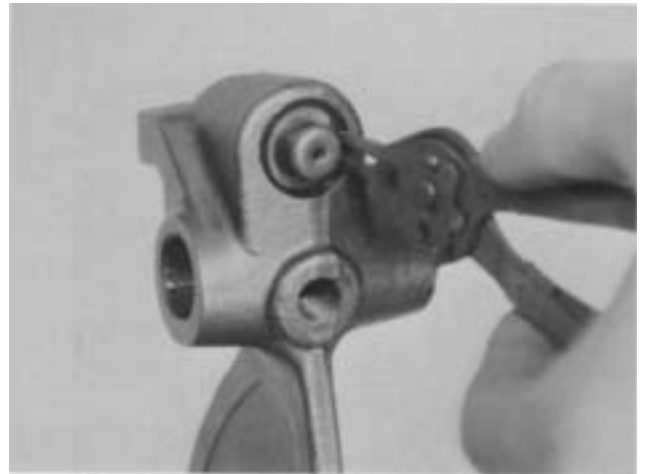

4. Install the retaining snap ring.
5. Check the plunger for smooth operation by pushing it down into the bore several times and checking for free return.

DISASSEMBLY AND REASSEMBLY SHIFTING CONTROLS

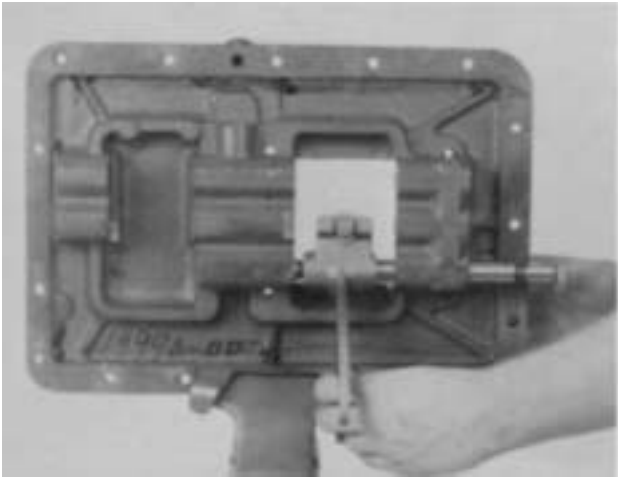

6. Install the reverse rail through the reverse yoke, with the neutral notches to the rear.

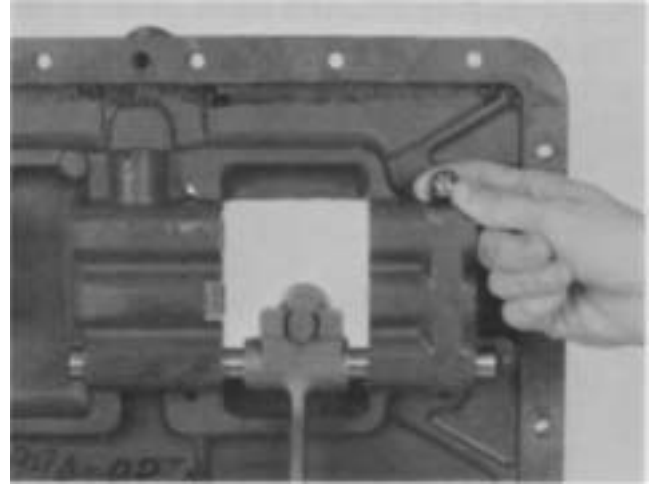

8. Drop first interlock ball into web.

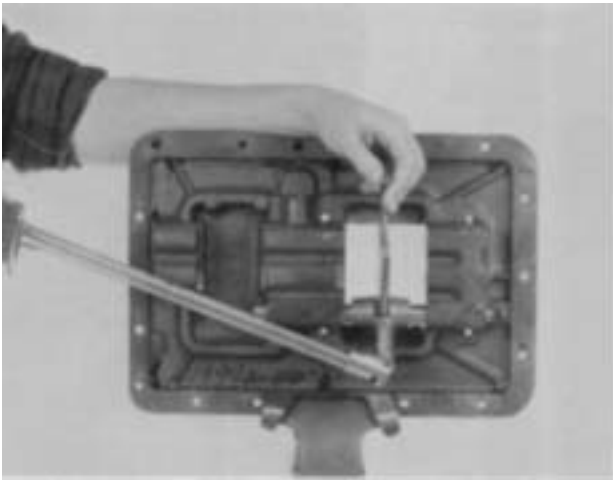

7. Line up the hole in the rail with the hole in the yoke and install capscrew.

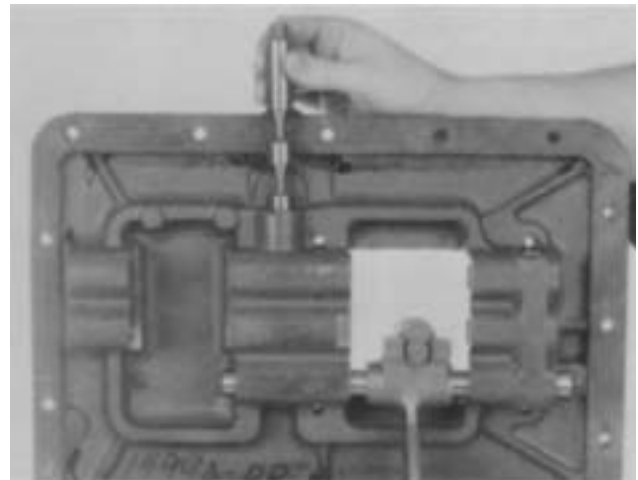

9. Install range plunger in bore.

CAUTION: Do not torque capscrews beyond 45 ft. lbs. or rails could be distorted.

DISASSEMBLY AND REASSEMBLY SHIFTING CONTROLS

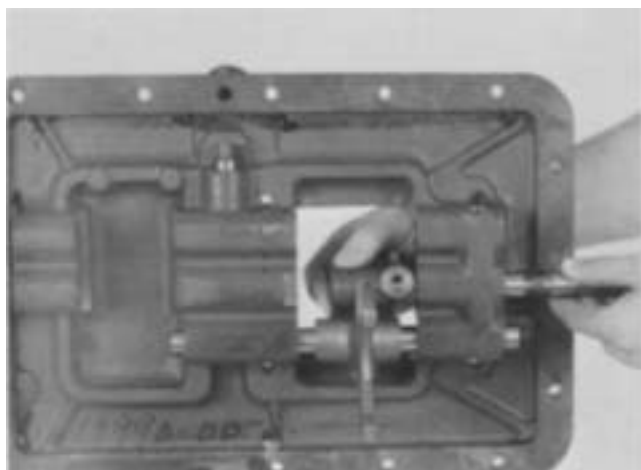

10. Put reverse rail in neutral and start center rail partially in, installing center block with tapped hole toward the rear.

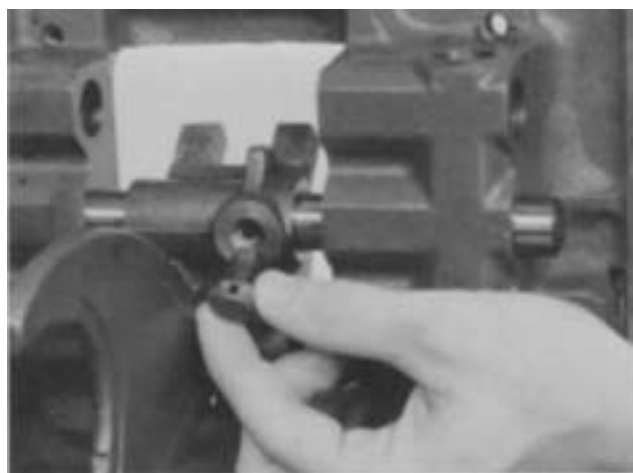

12. The shorter cap screw with the beveled head must be installed in the center block.

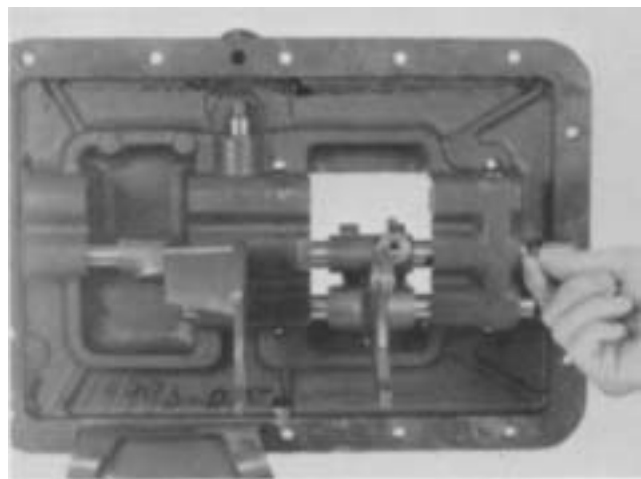

11. Install center yoke, and before pushing the rail completely in, install the interlock pin.

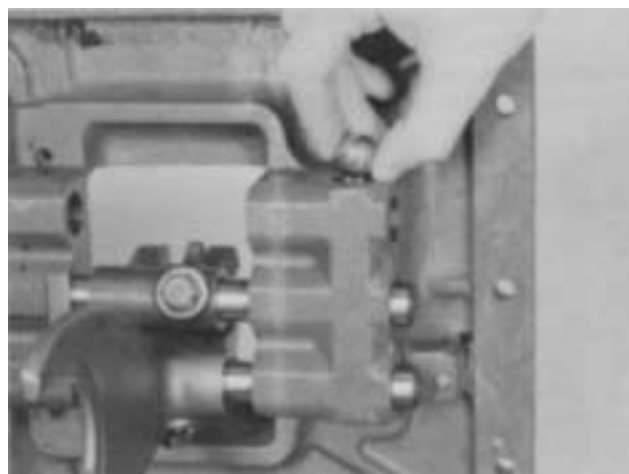

13. Drop the second ball in the web.

DISASSEMBLY AND REASSEMBLY SHIFTING CONTROLS

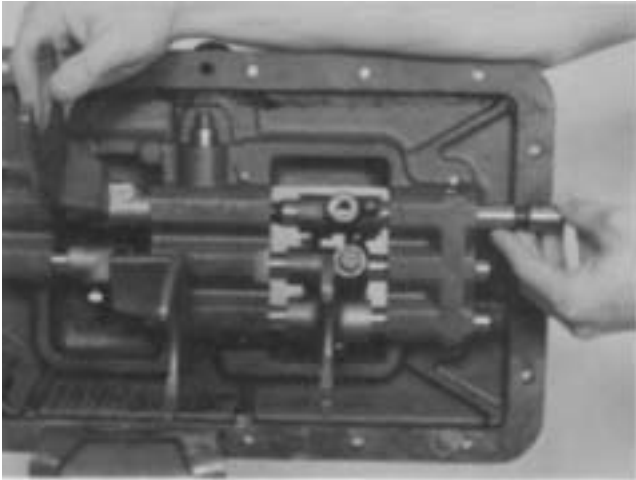

14. With the center and reverse rails in the neutral position, install the direct rail through the block and yoke.
15. Install all capscrews and lockwire.
16. Check that the lockout feature is working by putting one rail in gear and attempting to move the other two rails out of the neutral position. They should not move.

REMOVAL - COMPANION FLANGE, AUXILIARY SECTION AND CLUTCH HOUSING

COMPANION FLANGE, AUXILIARY SECTION AND CLUTCH HOUSING

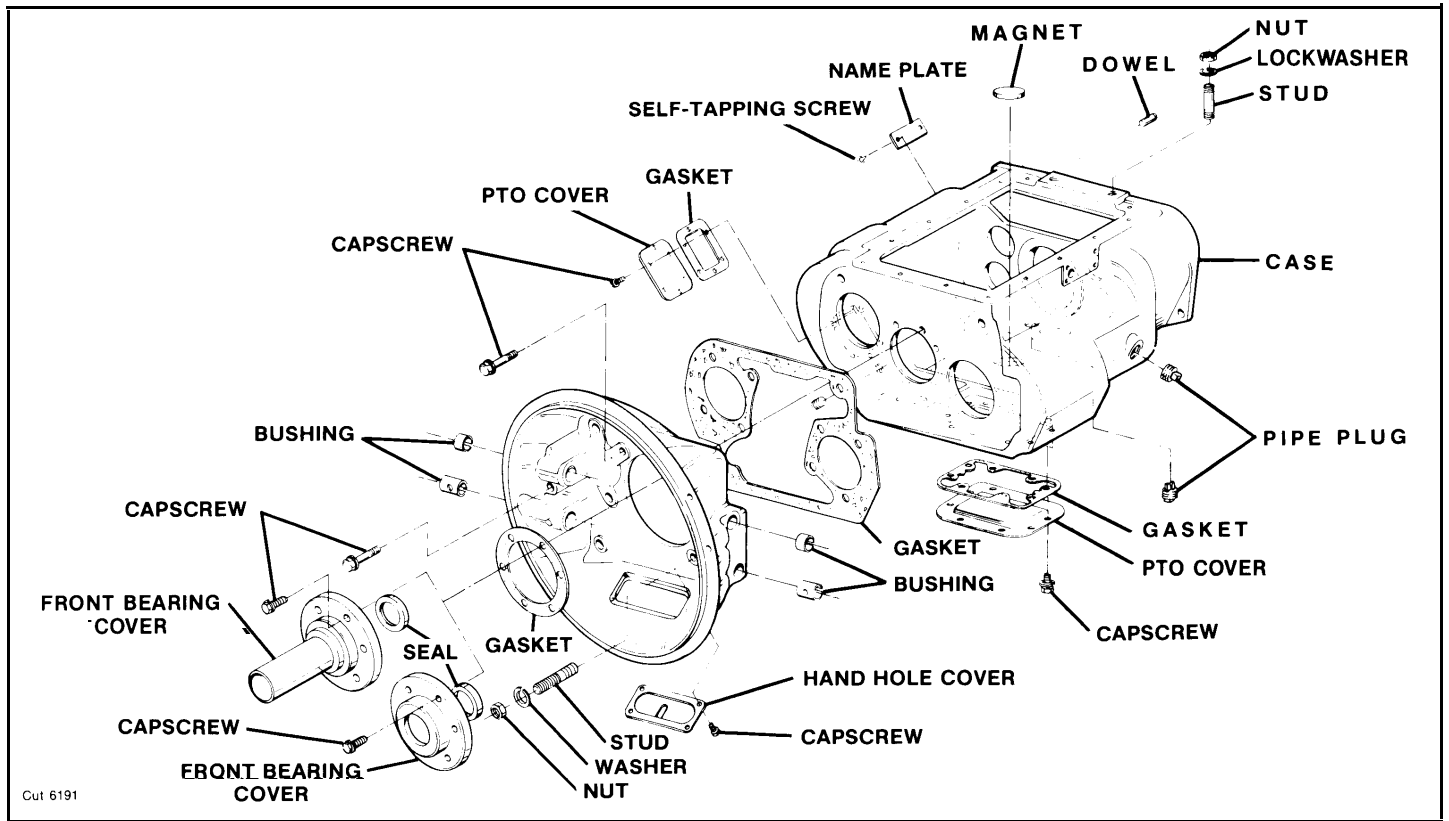

A. To Remove the Universal Joint Companion Flange or Yoke

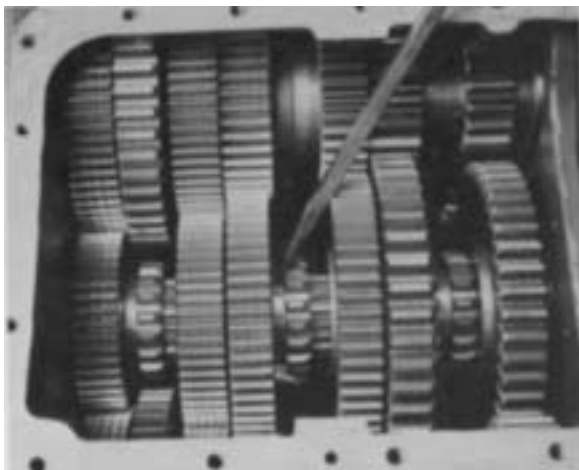

1. Lock the transmission by engaging two gears with the mainshaft sliding clutches.



2. Use a large breaker bar to turn output shaft nut from the output shaft

REMOVAL - COMPANION FLANGE, AUXILIARY SECTION AND CLUTCH HOUSING



3. Pull the companion flange or yoke from splines of output shaft.



4. Remove the speedometer drive gear or replacement spacer from hub of flange/yoke or from inside rear bearing cover remaining on output shaft (inset). For some models, it is necessary to remove the snap ring in groove of output shaft PRIOR to removal of the speedometer gear or spacer.

NOTE: Temporarily reinstall output shaft nut to protect the threads during auxiliary removal.

B. To Remove the Auxiliary Section from Transmission

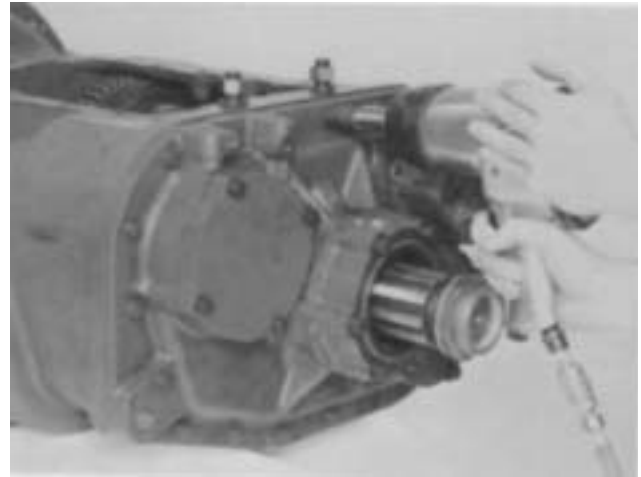

1. Turn out the capscrews that attach the two sections.
2. Insert three puller screws in the tapped holes of housing flange.

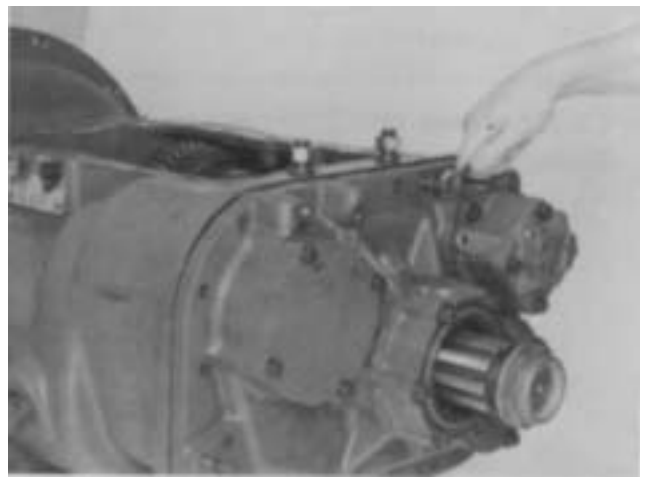

3. Tighten puller screws evenly to move auxiliary section to the rear and just far enough from front section to break gasket seal.

REMOVAL - COMPANION FLANGE, AUXILIARY SECTION AND CLUTCH HOUSING



4. Attach lifting eye to auxiliary and hook a hoist into position before sliding auxiliary section completely off dowels.
5. Remove the gasket from the front section.

C. Removal of Clutch Housing

1. For models so equipped, remove the clutch release mechanism and/or clutch brake assembly. See OPTIONS.



2. Turn out the four capscrews and remove the six nuts and lockwashers from studs securing the clutch housing to transmission case.



3. Jar clutch housing with a rubber mallet to break gasket seal and pull from transmission case. Remove gasket.

DISASSEMBLY - AUXILIARY SECTION

AUXILIARY SECTION (LOW)

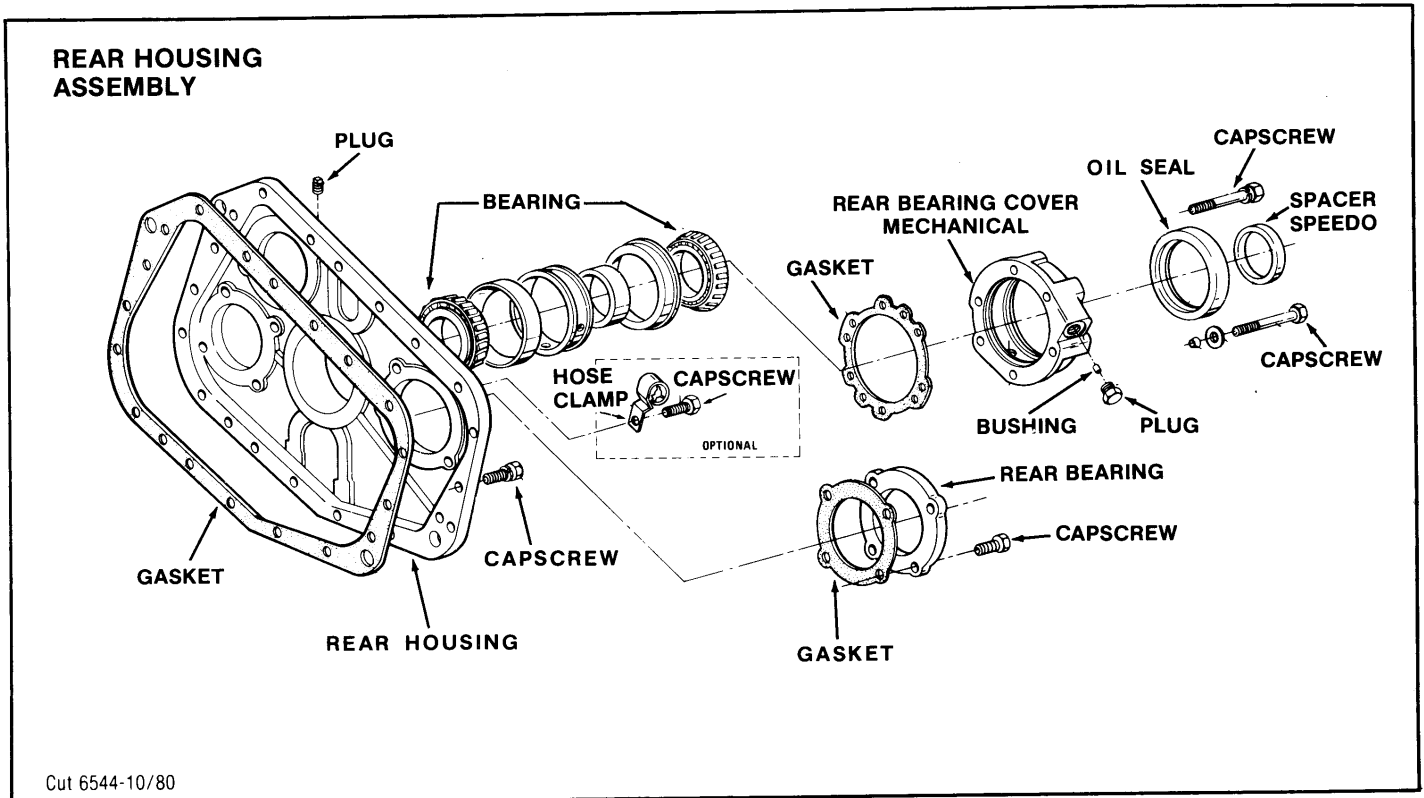

A. To Remove The Auxiliary Countershaft Assemblies



1. Remove countershaft bearing covers and the range cylinder cover.

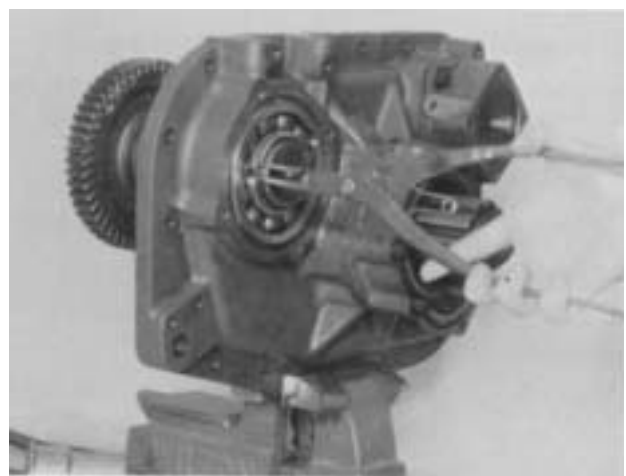

2. Remove the countershaft snap ring.

DISASSEMBLY - AUXILIARY SECTION

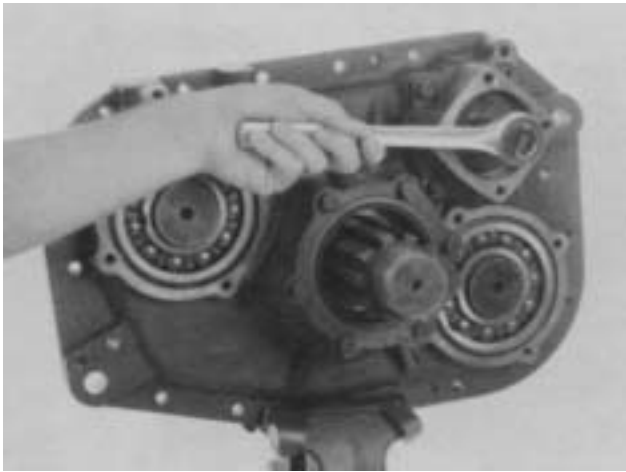

3. Remove the locknut holding the range piston in the housing.

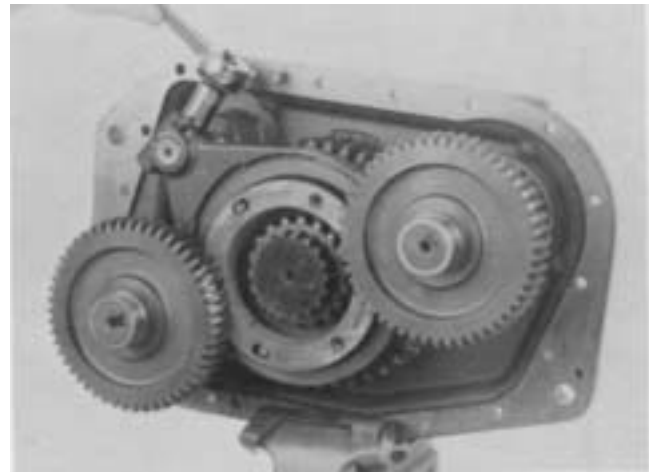

5. Remove the cap screws from the shift yoke.



4. Cut the lockwire from the shift yoke cap screws.

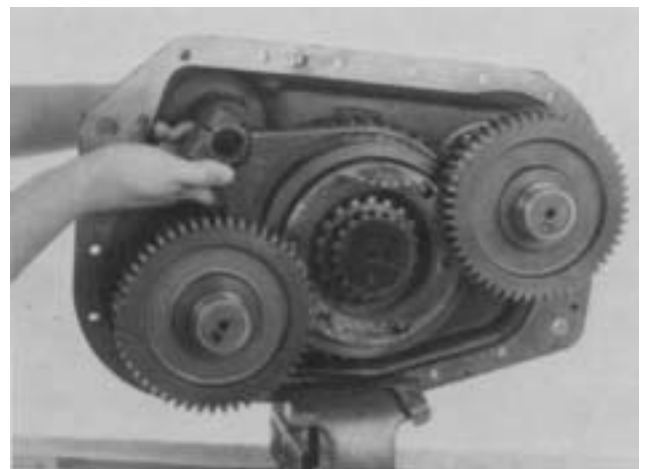

6. Slide the yoke bar back slightly to provide clearance and lift out the shift yoke.

DISASSEMBLY - AUXILIARY SECTION

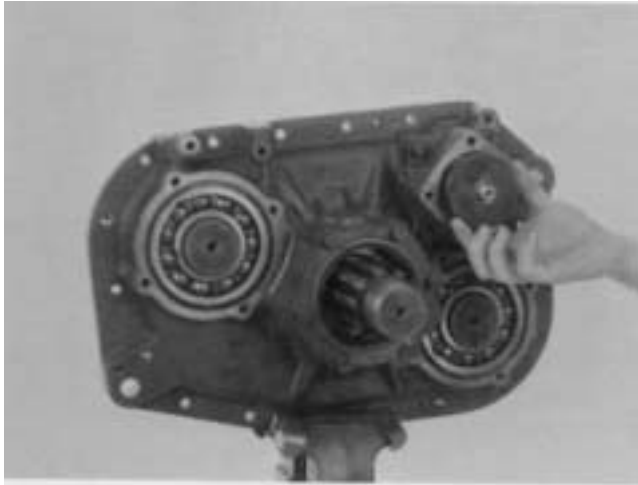

7. Remove the piston from the yoke bar.



9. Drive the countershaft assemblies out through the countershaft bearings using a soft bar and maul.

NOTE: Support the countershaft on the input side to prevent them from dropping.

10. If necessary, secure the assembly in a vise and remove the bearing inner race from front of countershaft with jaw pullers.

NOTE: The vise used should be equipped with brass jaws or wood blocks to prevent damage to the countershaft.

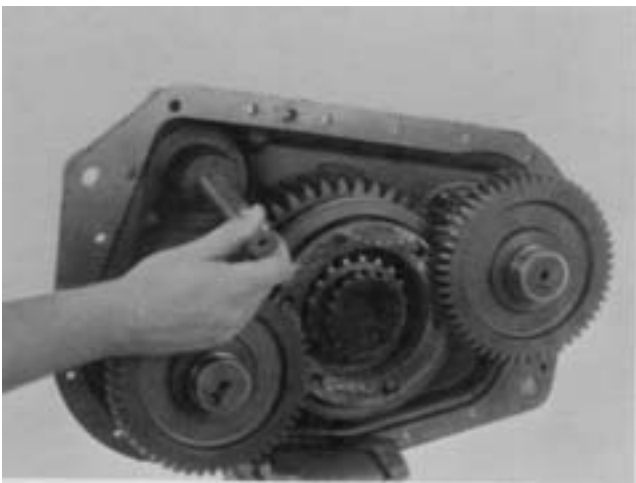

8. Pull the yoke bar out the input side of housing.

DISASSEMBLY - AUXILIARY SECTION

REAR HOUSING ASSEMBLY

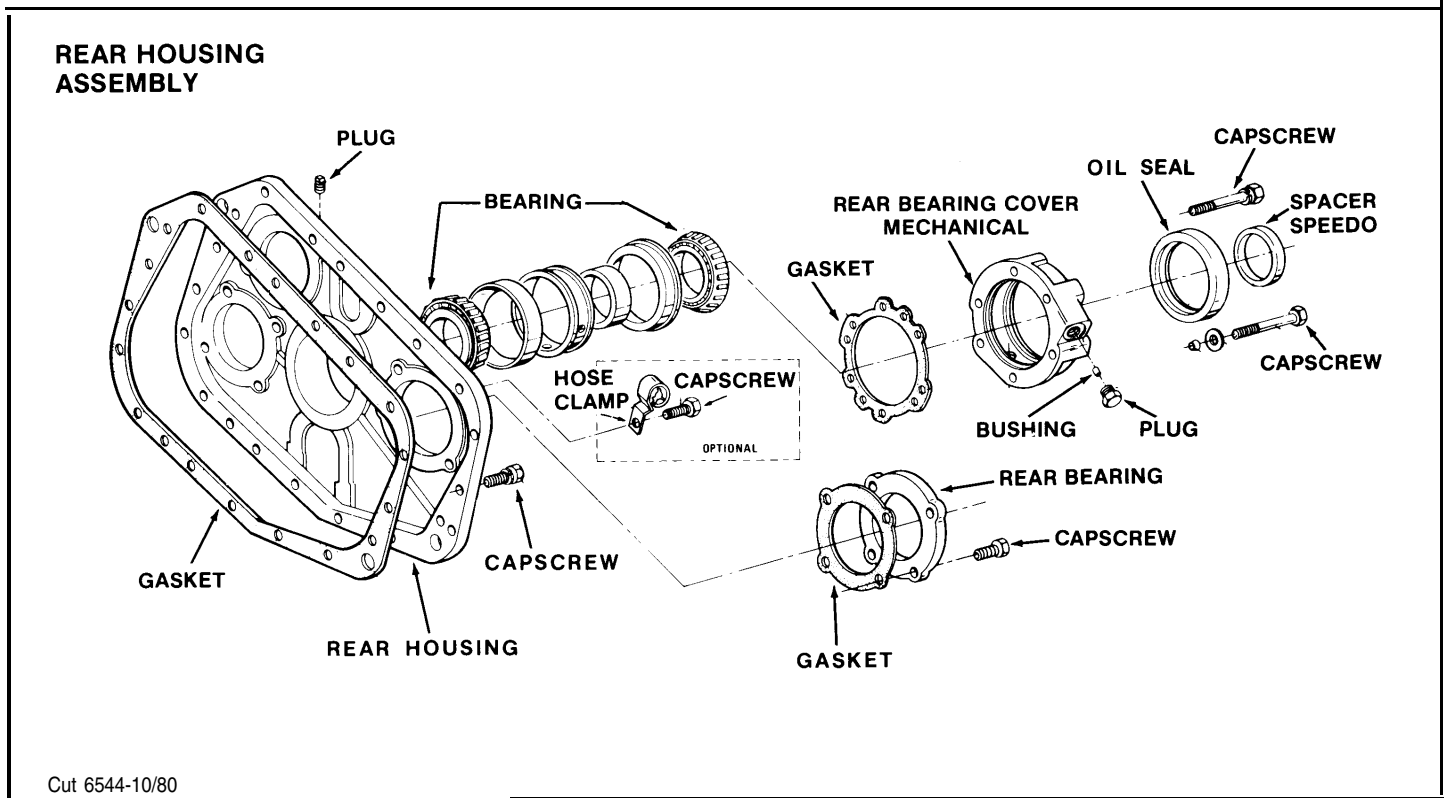

B. To Remove the Synchronizer Assembly, Mainshaft Assembly and Range Shift Air Cylinder



1. Slide the synchronizer assembly off the mainshaft.

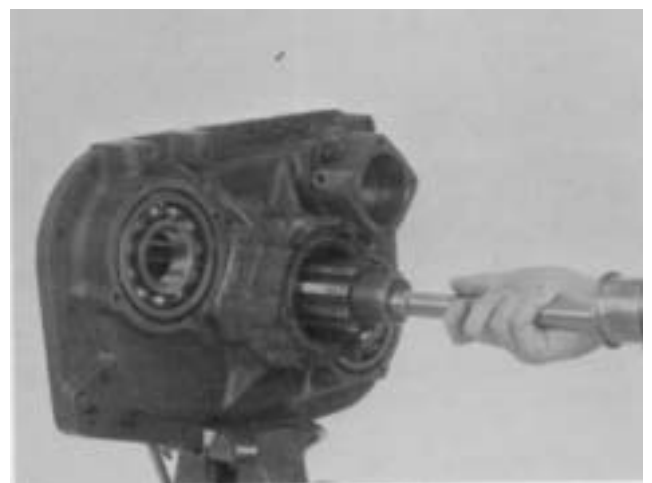

2. Drive the mainshaft assembly out using a soft bar and maul.

NOTE: Support the gear while driving.

DISASSEMBLY - AUXILIARY SECTION

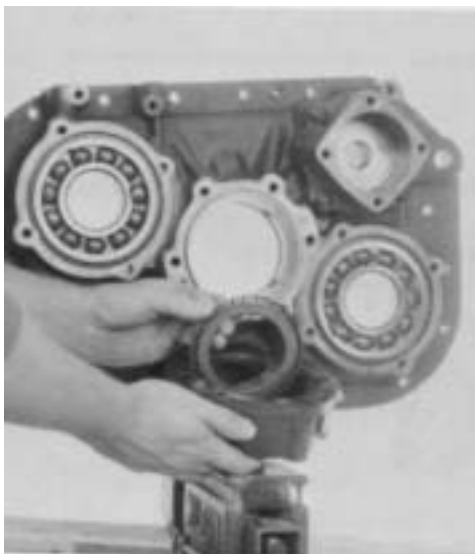

3. Remove the rear bearing cover and the outer roller bearing.

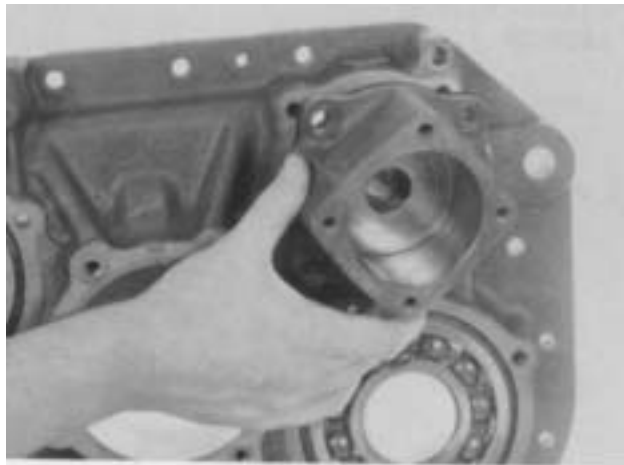

5. Remove the range cylinder housing.

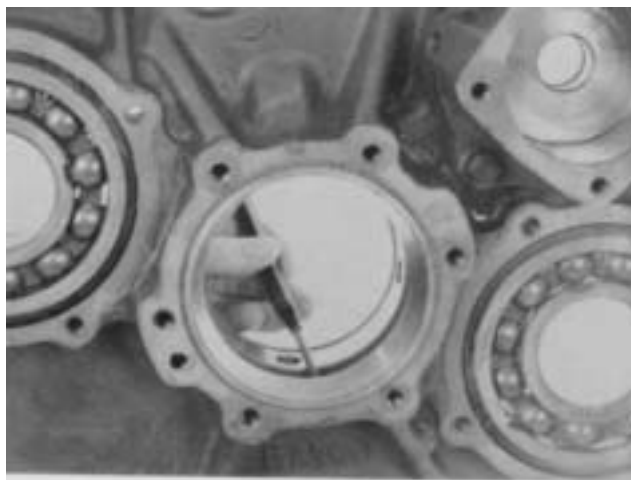

4. Tap out bearing cups and spacer using a soft punch.



6. Remove the O-Ring from the small bore in the housing if it is damaged or needs replacement.

DISASSEMBLY - AUXILIARY SECTION



7. Remove the countershaft bearings with a flat driver and a maul.

DISASSEMBLY - AUXILIARY SECTION

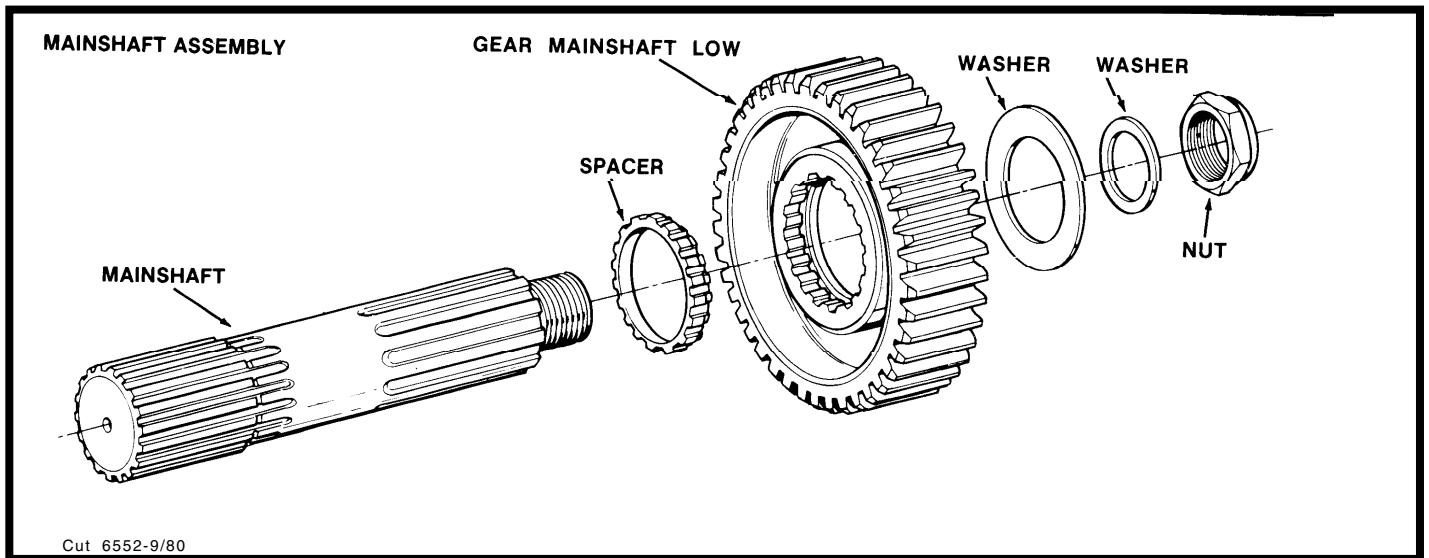

C. Mainshaft Disassembly



1. Remove the bearing inner spacer from the mainshaft.

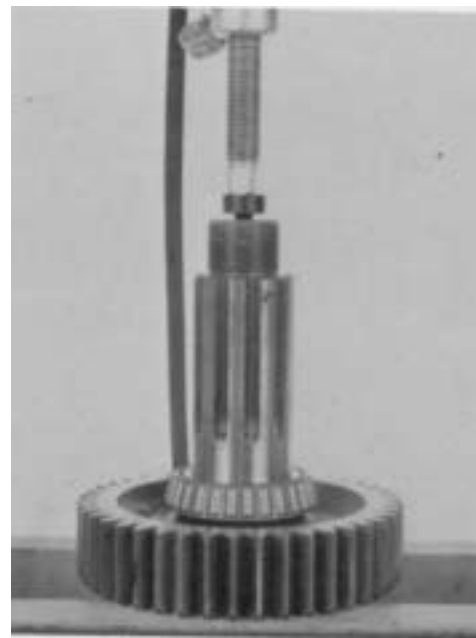

2. Press the inner bearing from the mainshaft.

CAUTION: Support the mainshaft from below so it does not drop and sustain damage during the pressing operation.

DISASSEMBLY - AUXILIARY SECTION



3. Remove the spline washer from the hub of low speed gear.

DISASSEMBLY - AUXILIARY SECTION

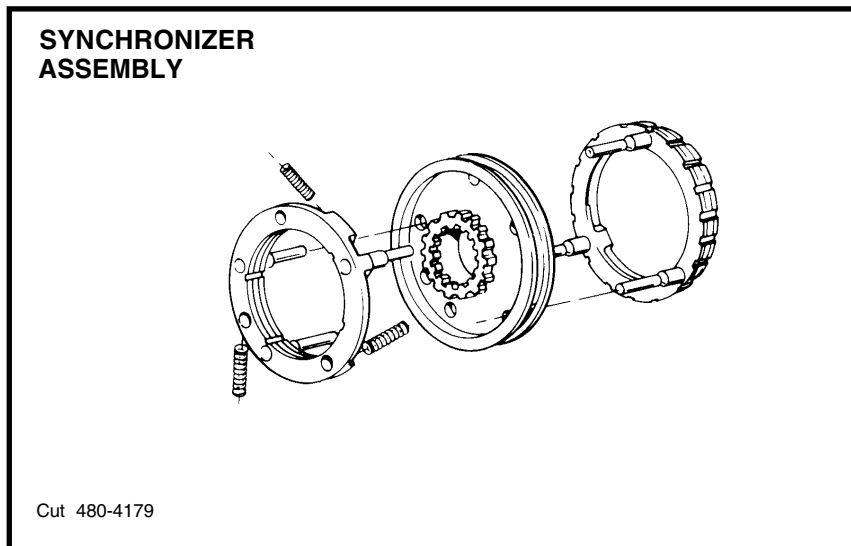

D. Synchronizer Disassembly



1. Pull upward to remove the high range synchronizer from pins.



2. Remove the sliding clutch from low range synchronizer pins.

CAUTION: There are three springs which will be released as the high range synchronizer is removed from the pins. Cover the assembly with a rag to prevent losing springs.

REASSEMBLY - AUXILIARY SECTION

AUXILIARY SECTION (LOW)

A. Mainshaft Reassembly

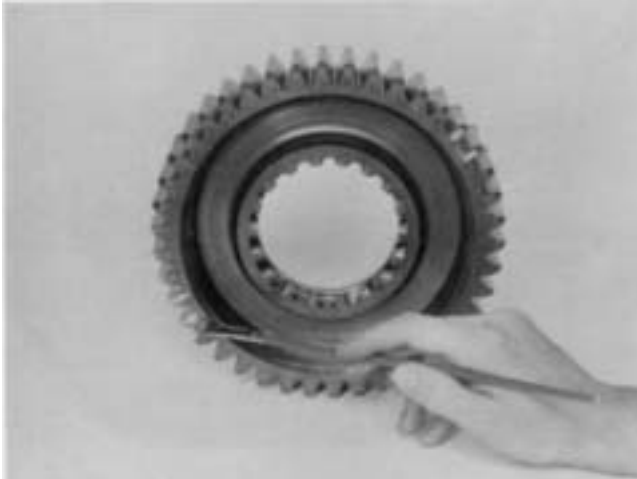

1. Mark two adjacent gear teeth, and two teeth 180° from the first two teeth for timing purposes.

IMPORTANT! There should be the same number of teeth between the markings on each side of the gear.



2. Place the spline spacer in hub of low speed gear, shoulder toward rear.



3. Install low speed gear on mainshaft with clutching teeth down.



4. Install the spacer washer with chamfer side up.

REASSEMBLY - AUXILIARY SECTION

B. Mainshaft Installation



5. Heat the rear bearing in oil to 50°F and drop down into position on mainshaft.

CAUTION: Use asbestos gloves when handling heated bearings.

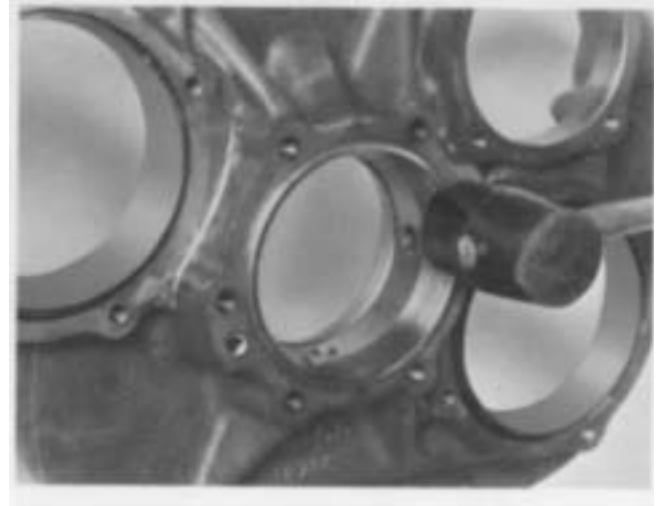

1. Install the outer bearing races and spacer into the housing. Make certain the lip on the outer race seats against the housing.



6. Install the inner race spacer above the bearing on the mainshaft.



2. Position the mainshaft and gear assembly in the housing.
3. Heat the outer bearing in oil to 250°F. Slide the bearing into position and hold in place until it cools and seats on the shaft.

REASSEMBLY - AUXILIARY SECTION

4. If previously removed, install the oil seal in rear bearing cover, lip of seal to the rear. The spring in the seal should be toward the inside of the transmission.

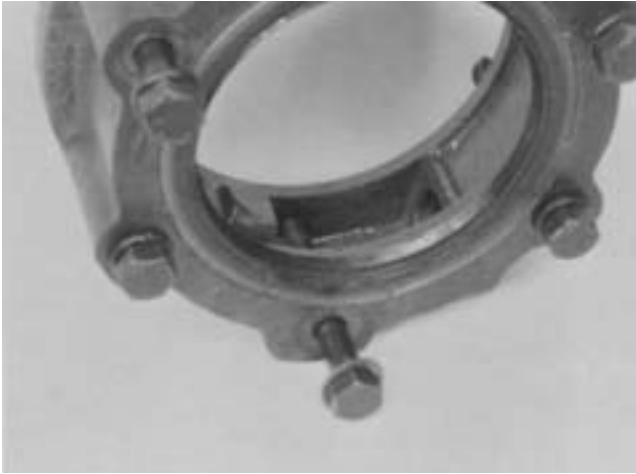

5. Locate the unshielded capscrew hole in the rear bearing cover, and install the capscrew with the brass washer (or brass washer and plastic sleeve, depending on model) in this hole.

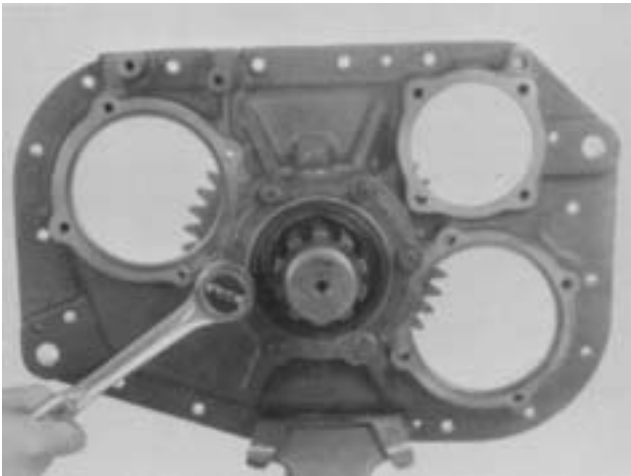

6. Bolt the cover into place using a new gasket.

NOTE: The cover may be rotated 180° for proper speedometer opening location.

C. Synchronizer Reassembly



1. Place the larger low range synchronizer face down on the bench with pins up. Install the sliding clutch (recessed side up) down over the pins on the synchronizer.

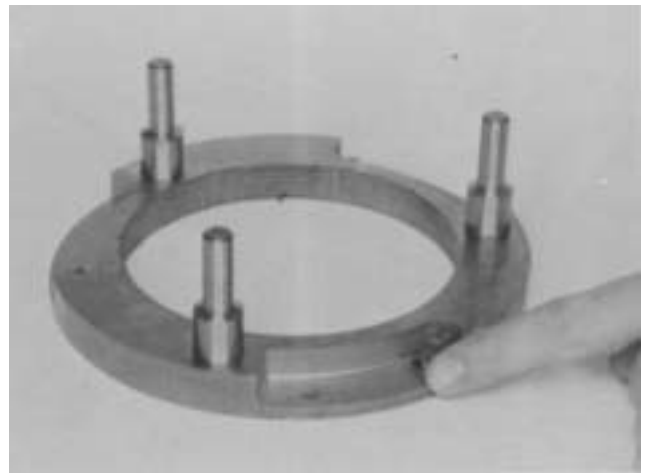

2. Install the three springs into their bores.

REASSEMBLY - AUXILIARY SECTION

D. Synchronizer Installation



3. Position the high range synchronizer ring so that the springs contact the side of the low speed synchronizer pins. Seat the ring by pushing down and twisting counterclockwise to compress springs.



1. Position the synchronizer in the low range position, and slide the assembly onto the mainshaft.

REASSEMBLY - AUXILIARY SECTION

E. Countershaft Installation

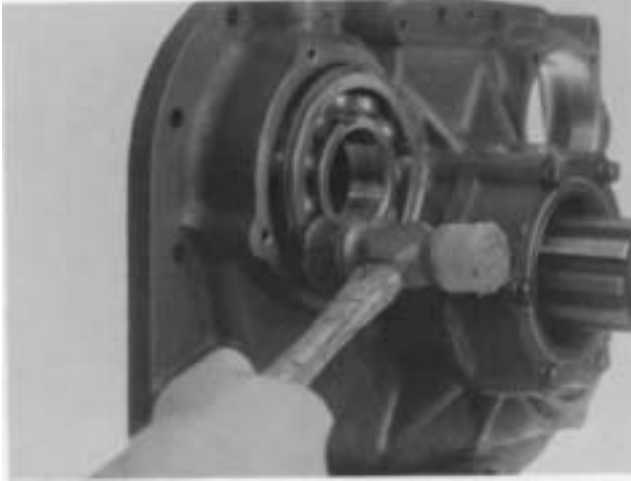

1. Seat the bearings part way in the bores with a soft mallet.
2. If previously removed, install the bearing inner race on front of each countershaft.



4. Mesh the marked tooth on each countershaft with the marked teeth on the mainshaft gear, and slide the countershaft into position.



3. Locate gear tooth on both countershaft with "O" stamp and mark for timing.

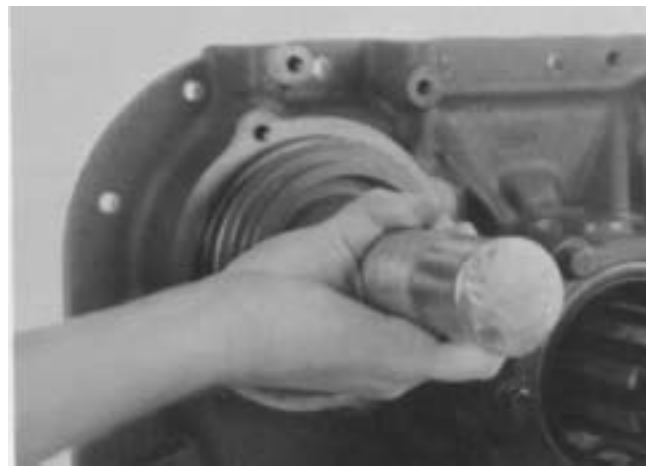

5. Drive the countershaft bearings into the housing with a stepped driver and maul, until both bearings are fully seated on the shoulder in housing.

REASSEMBLY - AUXILIARY SECTION

6. With a soft bar and maul, drive the countershafts to the rear to expose snap ring grooves in countershaft.

NOTE: It will be necessary to temporarily install the bearing covers to hold the countershaft bearings in place during this operation.

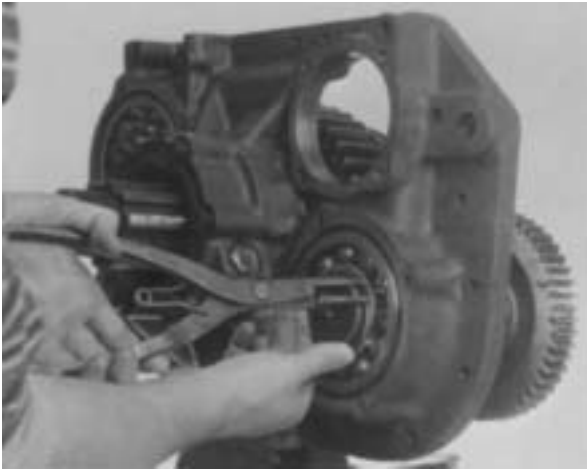

7. Install the snap rings.



8. Reinstall the rear bearing covers using new gaskets.

F. Range Cylinder Installation

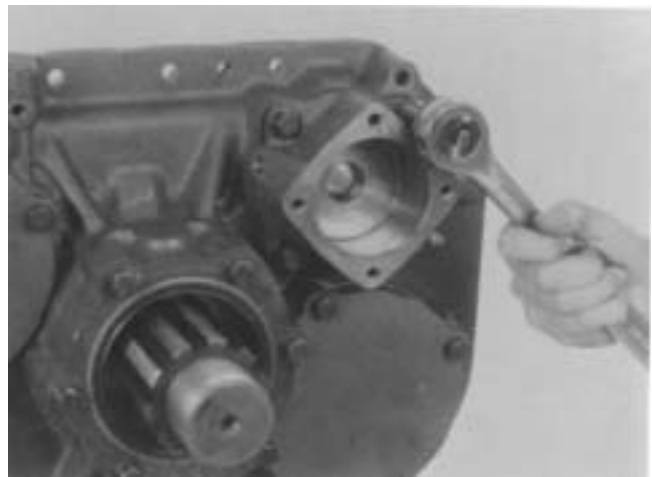

1. Bolt the cylinder housing into place using a new gasket.

NOTE: The air port should be located in the 10 o'clock position.

REASSEMBLY - AUXILIARY SECTION

2. If previously removed, lubricate the O-ring and install in the small bore in the cylinder.



3. Position the shift yoke, and slide the yoke bar through the shift yoke and into the cylinder body from the input side.

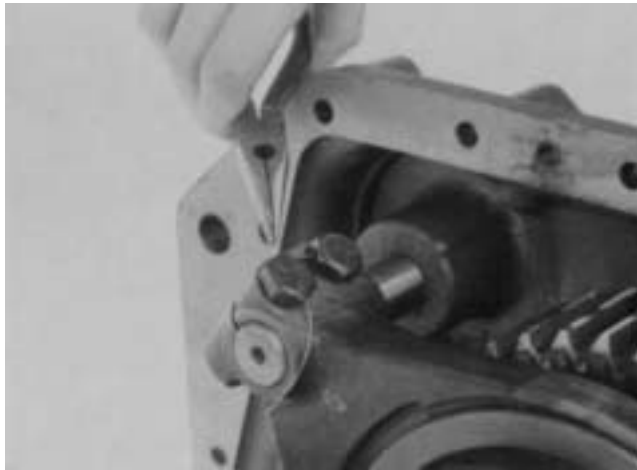

4. Install the yoke cap screws and lock with safety wire.

5. Install O-rings on OD and ID of piston and apply a light coat of silicone lubricant to the O-rings,



6. Install the piston in the housing with the stepped face to the inside.

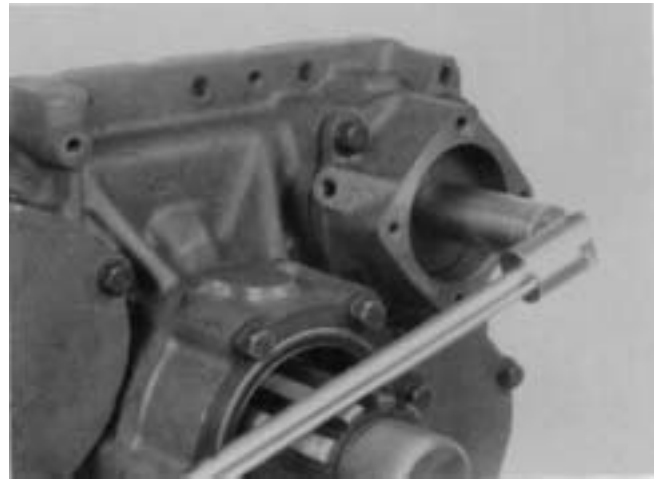

7. Install a new locknut on the yoke bar to secure the piston.

REASSEMBLY - AUXILIARY SECTION

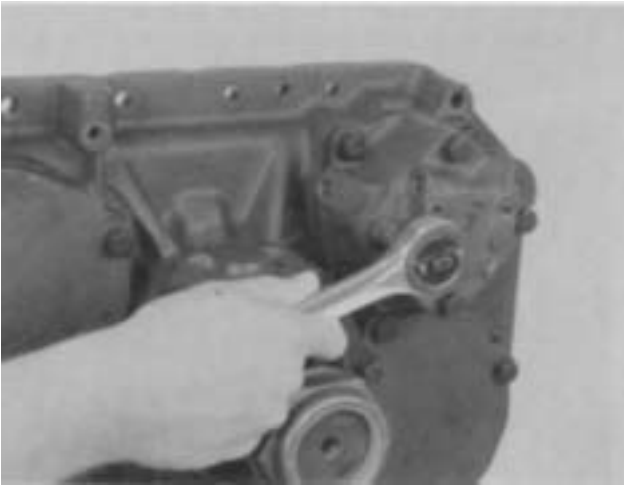

8. Install the cylinder cover using a new gasket.

NOTE: The air port opening should be located at the 11 o'clock position.

DISASSEMBLY - AUXILIARY SECTION

AUXILIARY SECTION (LOW - LOW)

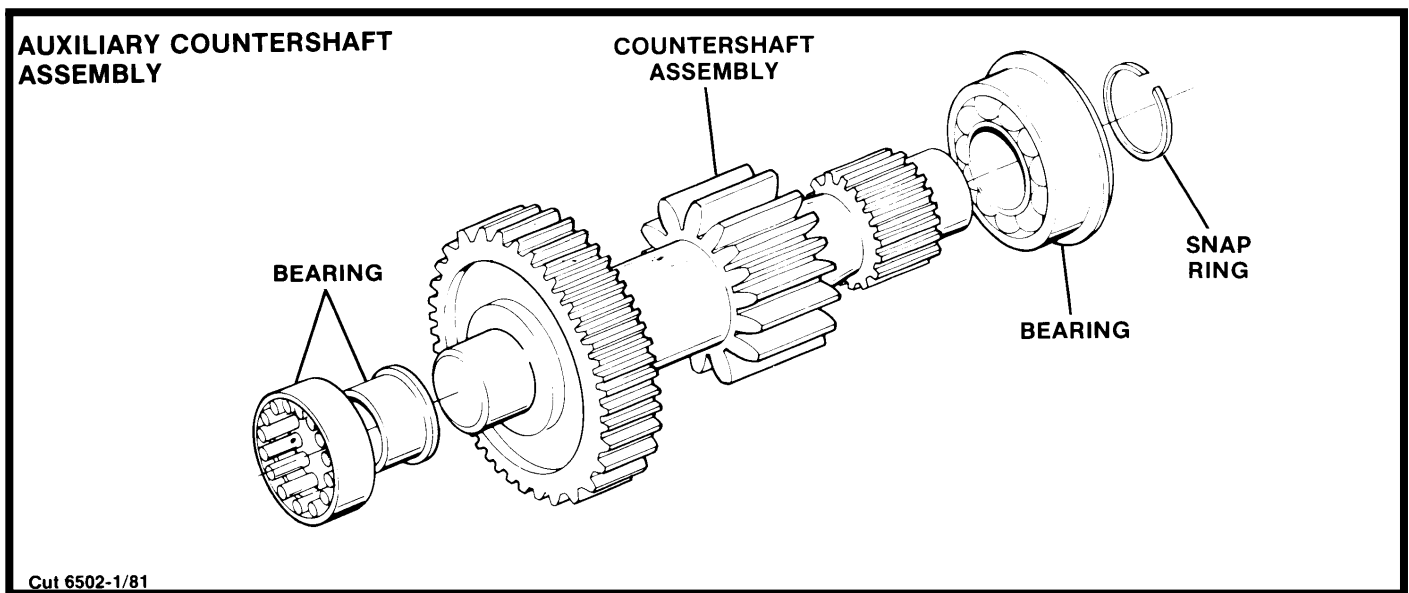

A. Countershaft Removal

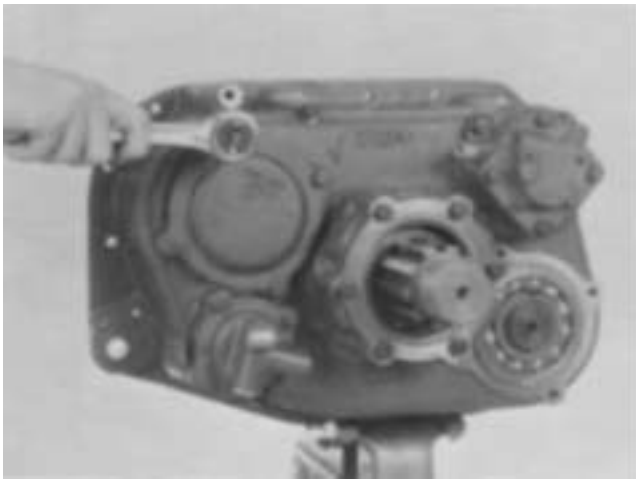

1. Remove the countershaft bearing covers.

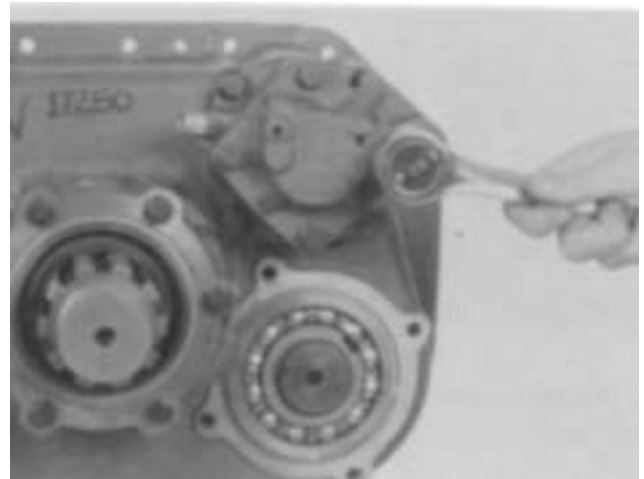

2. Remove the range cylinder cover.

DISASSEMBLY - AUXILIARY SECTION



3. Remove the locking nut from the range yoke shaft and discard.

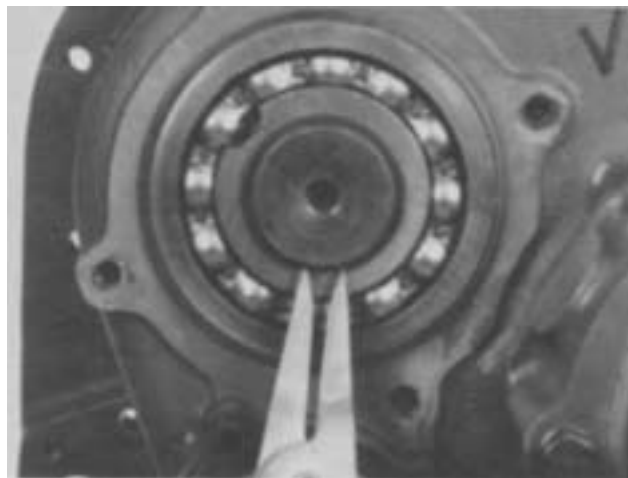

5. Remove the snap rings from the countershaft bearings.



4. Remove the reduction cylinder cover.



6. Cut the lockwire and remove cap screws.

DISASSEMBLY - AUXILIARY SECTION

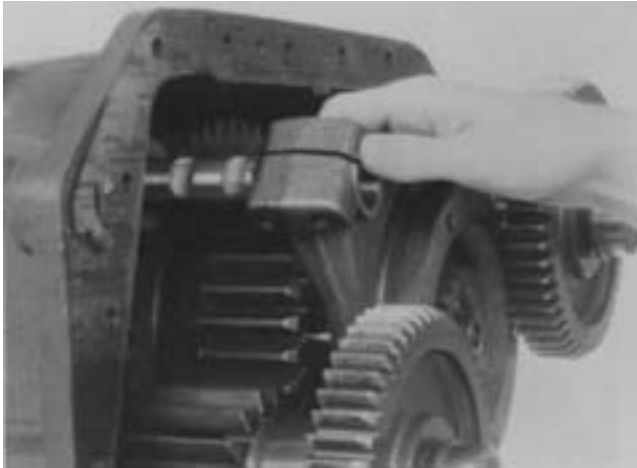

7. Slide the yoke bar part way into the range cylinder housing to allow clearance for the shift yoke to be lifted out.

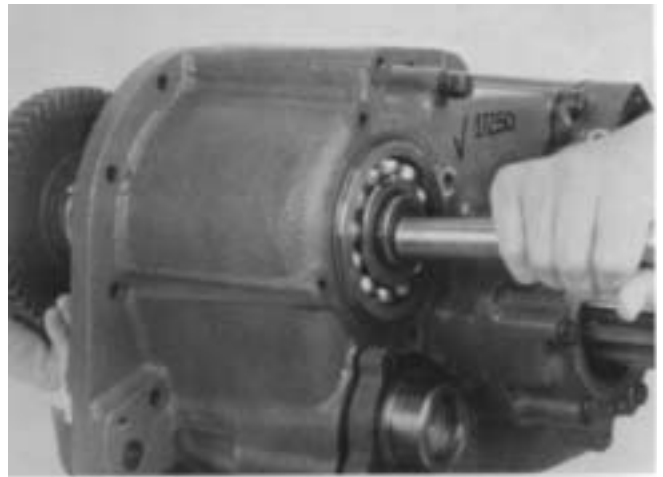

9. Drive out countershaft using a soft-bar and maul.
CAUTION: Support the countershaft from the gear side to prevent them from dropping.



8. Remove piston from yoke bar, and slide yoke bar out from gear side of housing.

10. If necessary, secure the assembly in a vise and remove the bearing inner race from front of countershaft with jaw pullers.
NOTE: The vise used should be equipped with brass jaws or wood blocks to prevent damage to the countershaft.

DISASSEMBLY - AUXILIARY SECTION

B. Synchronizer and Low Range Gear Removal



1. Slide the synchronizer from the mainshaft.



3. Turn the tolerance washer to line up the splines and slide the low range gear off the mainshaft.



2. Remove the square key from the range mainshaft.



4. Remove spacer from inside low range gear.

DISASSEMBLY - AUXILIARY SECTION



5. Slide the coupler off mainshaft.

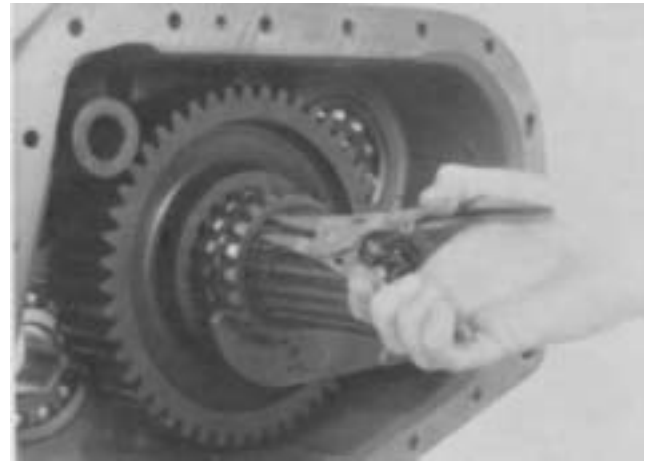

6. Remove the snap ring from the mainshaft.

DISASSEMBLY - AUXILIARY SECTION

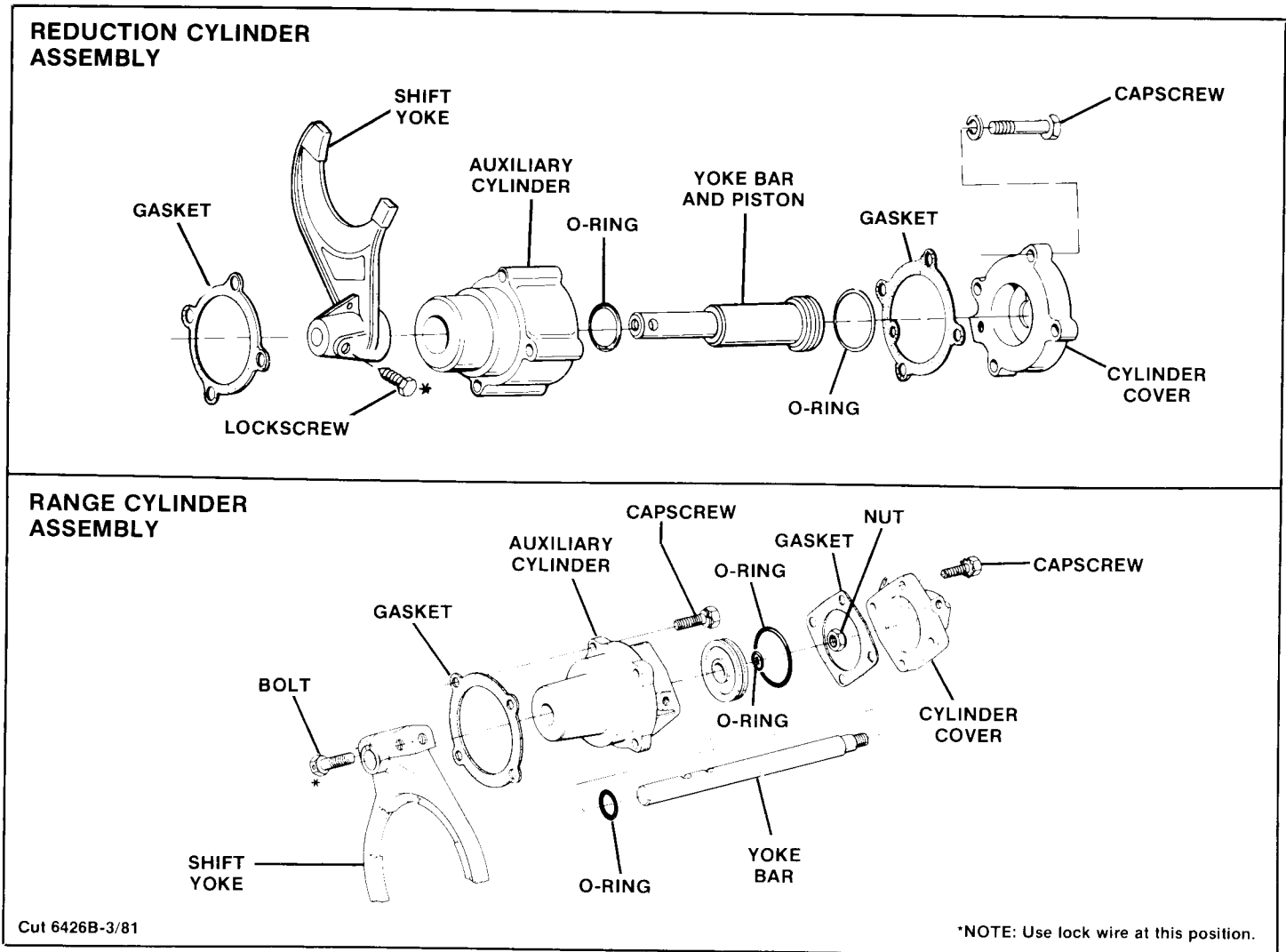

C. Reduction and Range Cylinder Removal

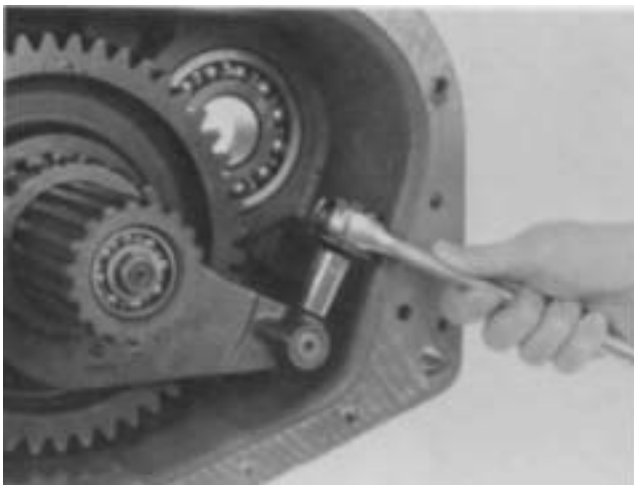

1. Cut lockwire and remove cap screw from reduction cylinder yoke.

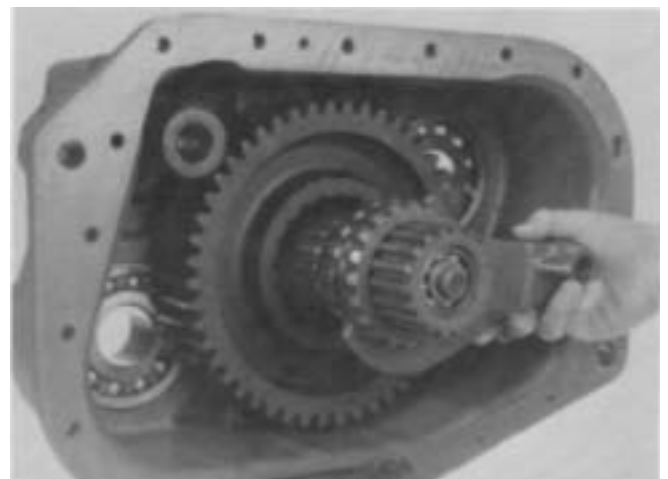

2. Slide yoke and reduction clutch forward off mainshaft.

DISASSEMBLY - AUXILIARY SECTION

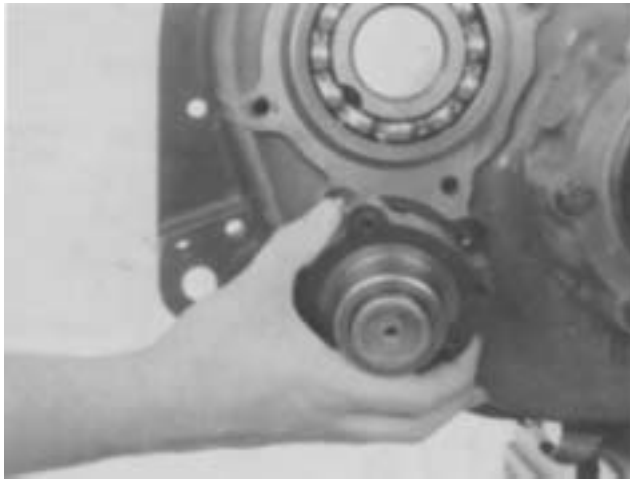

3. Remove the reduction cylinder body and yoke bar.

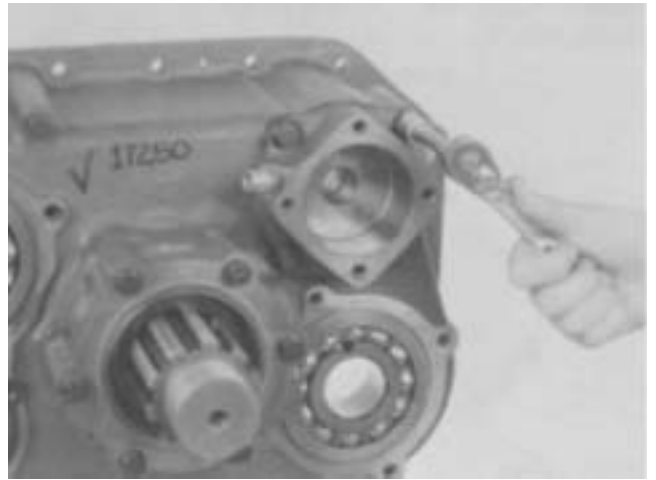

4. Remove the range cylinder body by removing cap screws.

DISASSEMBLY - AUXILIARY SECTION

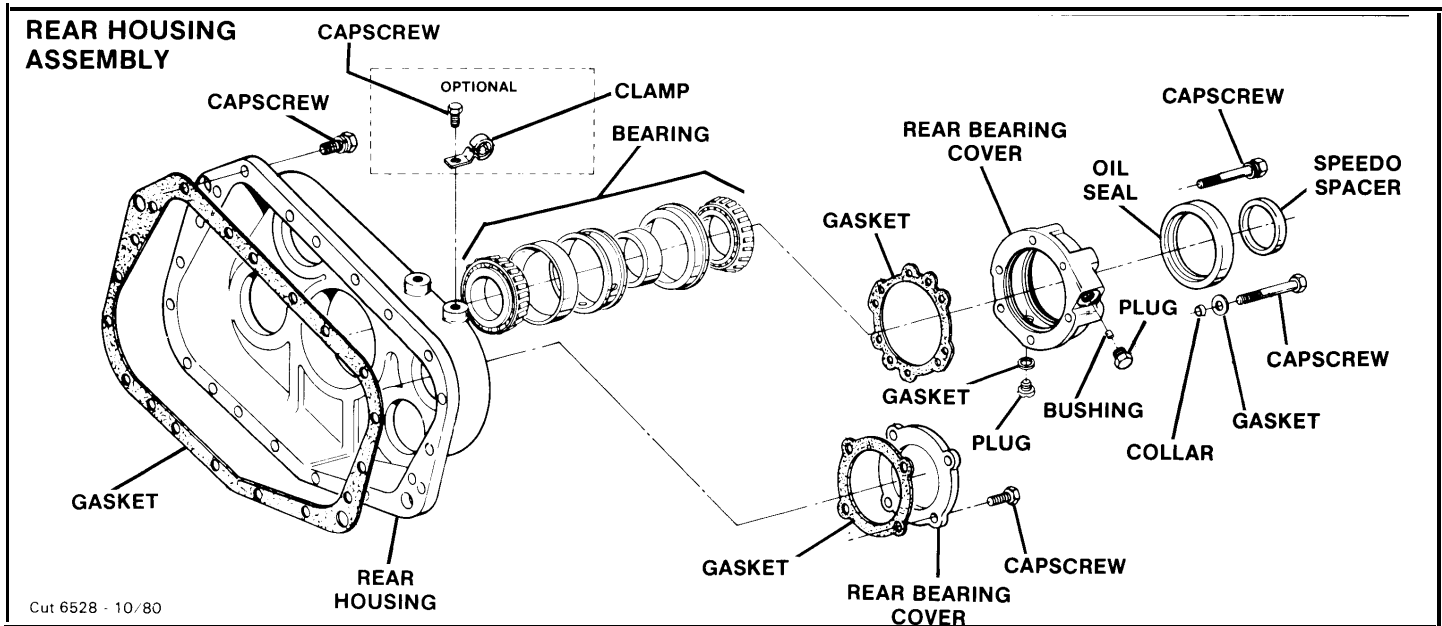

D. Mainshaft Removal



1. Remove C-ring from end of quill,



2. Pry range mainshaft off output shaft quill with two large screwdrivers.

NOTE: Bearing can be removed from range mainshaft if replacement is necessary.

DISASSEMBLY - AUXILIARY SECTION

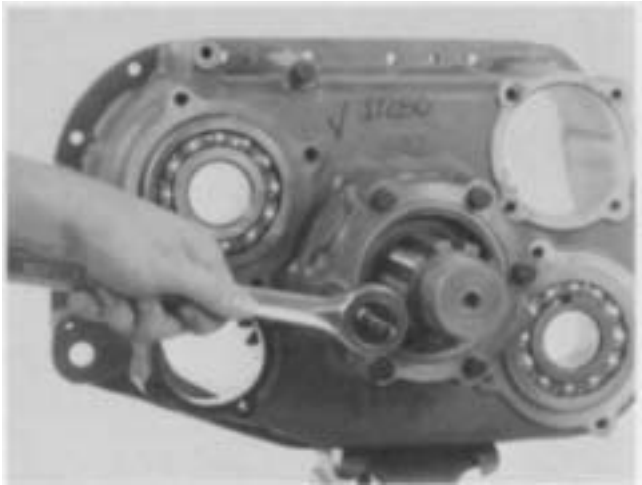

3. Remove rear bearing cover.



5. Slide speedspacer (or gear, depending on model) off output shaft.

6. Temporarily reinstall rear bearing cover.

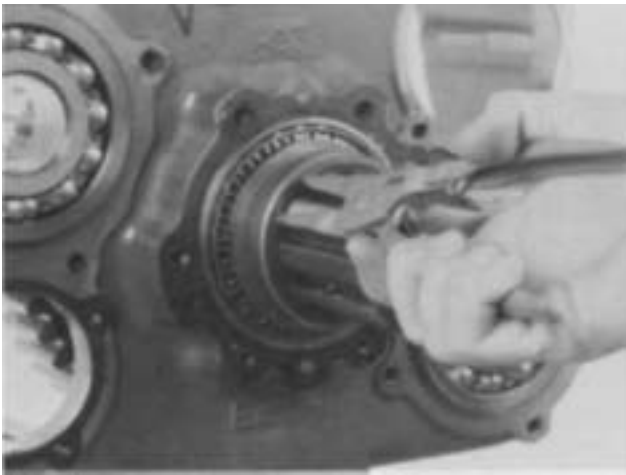

4. Remove snap ring from output shaft.

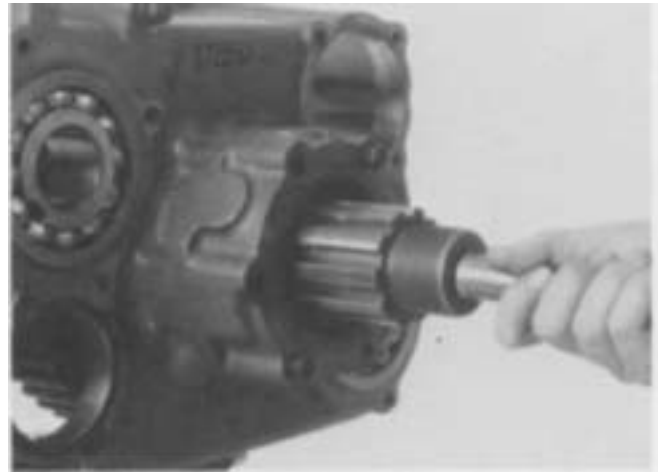

7. Drive the output shaft out through the bearing with a soft bar and maul.

8. Remove rear bearing cover.

DISASSEMBLY - AUXILIARY SECTION

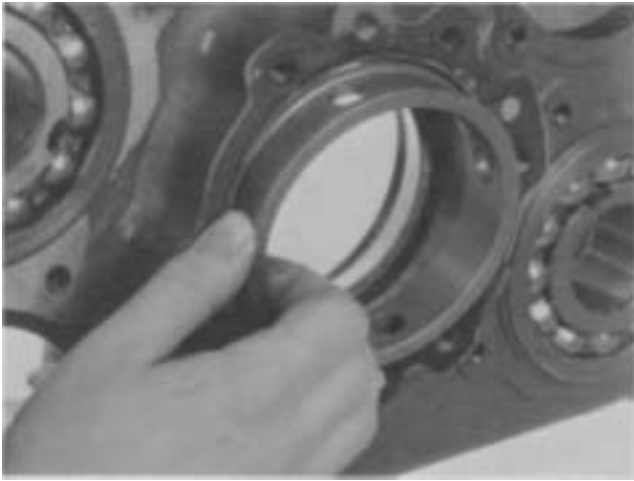

9. Remove the spacer and two outer races from bore.



10. Drive out the two countershaft bearings.

CAUTION: The bearing is a matched set. If one piece of the bearing is damaged, the whole set must be replaced.

DISASSEMBLY - AUXILIARY SECTION

E. Mainshaft Disassembly



1. Press the inner bearing and deep reduction gear off the mainshaft.



3. Remove the washer from inside the deep reduction gear.



2. Remove the spacer and oil retention ring from the deep reduction gear.

DISASSEMBLY - AUXILIARY SECTION

F. Reduction Cylinder Insert Valve Disassembly

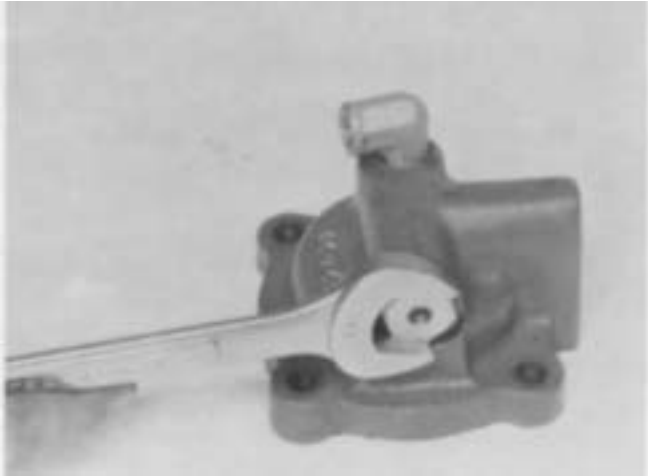

1. Remove the nut from the reduction cylinder cover.

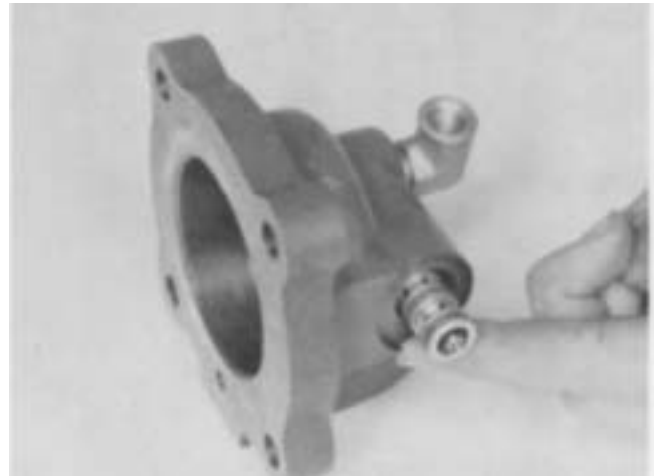

2. Remove the insert valve from the cover.

3. Check the orifices in the valve for obstructions, and check the O-rings for damage. Replace any damaged or questionable O-rings.

REASSEMBLY - AUXILIARY SECTION

AUXILIARY SECTION (LOW - LOW)

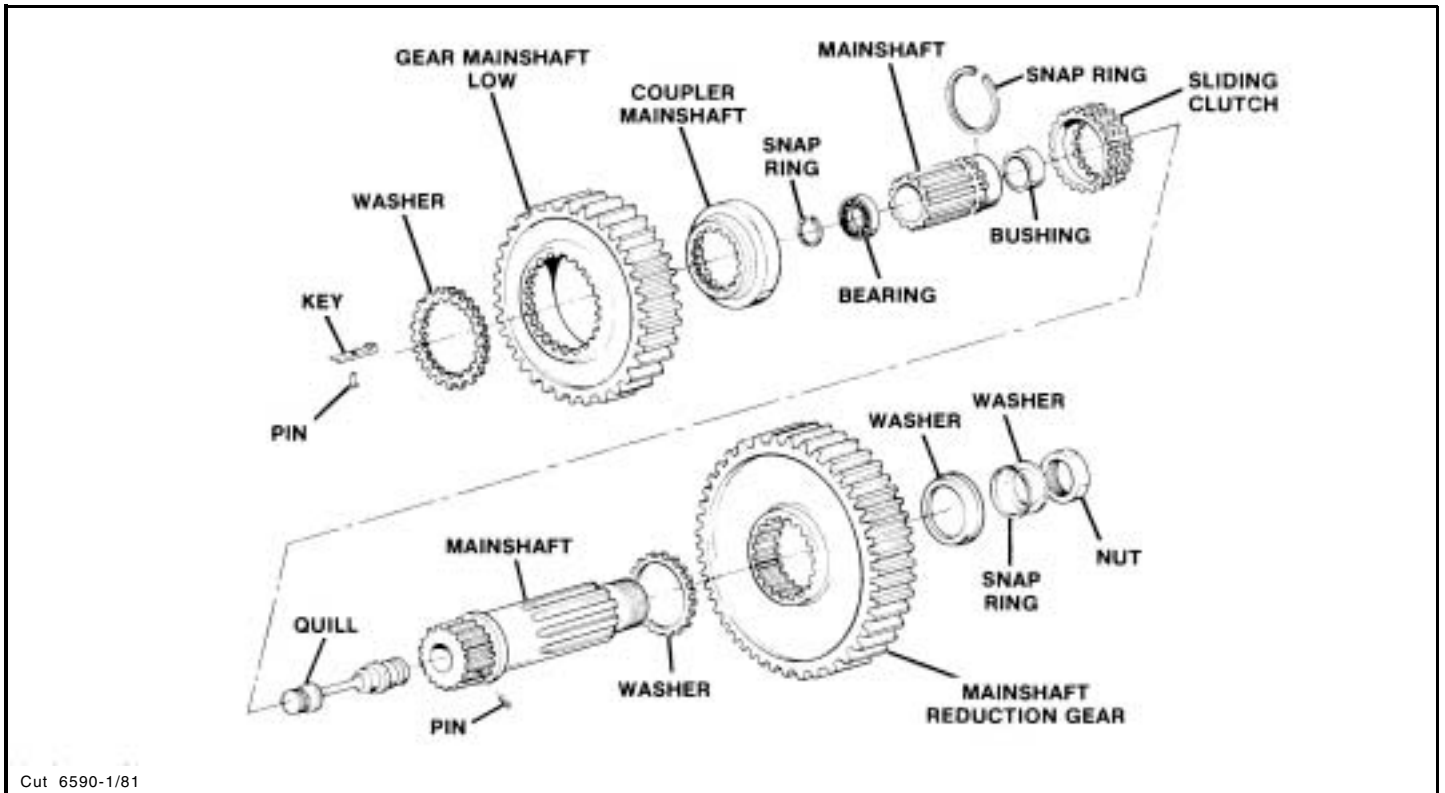

A. Mainshaft Reassembly



1. Use a driver to install range mainshaft and bearing on quill.



2. Use a "O" ring driver to install the C-ring on the nose of the quill.

REASSEMBLY - AUXILIARY SECTION



3. Mark two sets of gear teeth at a point 180 degrees apart for timing purposes.
4. Turn the mainshaft assembly over in the vise, and drop the externally splined washer down on the shaft.



6. Install the rear spacer with the machined surface riding on the machined surface of the gear.



5. Install the reduction gear on the mainshaft with conical clutching teeth facing down.

REASSEMBLY - AUXILIARY SECTION

B. Main Shaft Installation



1. Install the oil deflector in the rear housing bore with the cupped surface facing up. Use a large bearing driver to drive the deflector down until the top surface of the deflector is 2" below the machined surface of the output shaft bore.

NOTE: If available, use two bearing outer spacers stacked on top of each other to drive the oil deflector into the bore. The deflector will beat the proper depth when the top of the top spacer is flush with the machined surface of the output shaft bore.



2. Install the rear housing over the output shaft, allowing the housing to rest on the reduction gear.

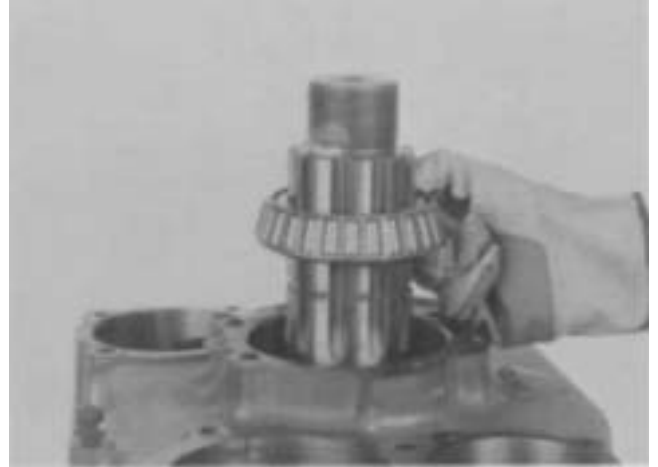

3. Heat the inner bearing in oil to 250°F and lower into place.

CAUTION: Use asbestos gloves when handling heated bearings.



4. Install the bearing inner spacer on the shaft and against the front bearing cone.

REASSEMBLY - AUXILIARY SECTION



5. Stack the two bearing cups and outer spacer in the output shaft bore in the proper sequence. Make sure that the front bearing cup taper matches the taper direction of the front bearing cone.



8. Put speed spacer (or drive gear) into place on shaft and install snap ring. Reposition housing in vise.
9. Tap the end of the output drive shaft with a soft bar and maul to make certain the mainshaft and bearings are seated.



6. Tap the two cups and outer spacer lightly and evenly into the case bore until the lip of the rear cup seats against the machined surface. It will be necessary to block under the rear housing slightly to permit the output shaft assembly to move far enough.
7. Heat and install the rear bearing cone on the shaft and in the rear cup, taper facing down.

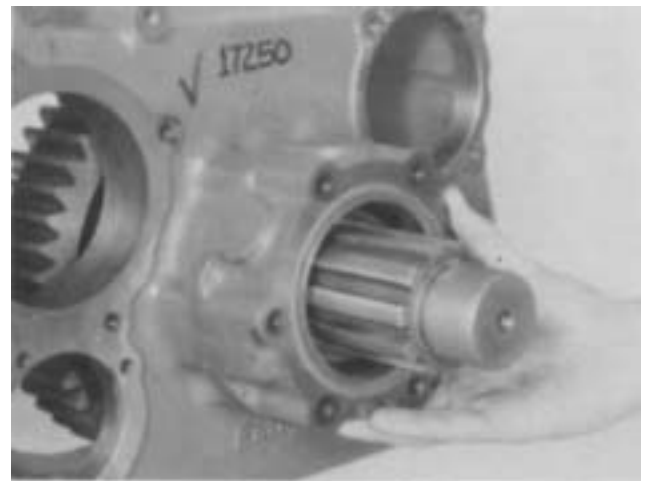

10. Install the rear bearing cover using a new gasket and positioning the speed drive gear bore at either the 10 o'clock or 3 o'clock position.

NOTE: The capscrew with the brass washer must be installed in the unshielded capscrew hole using a new plastic collar.

REASSEMBLY - AUXILIARY SECTION

C. Reduction Cylinder Assembly

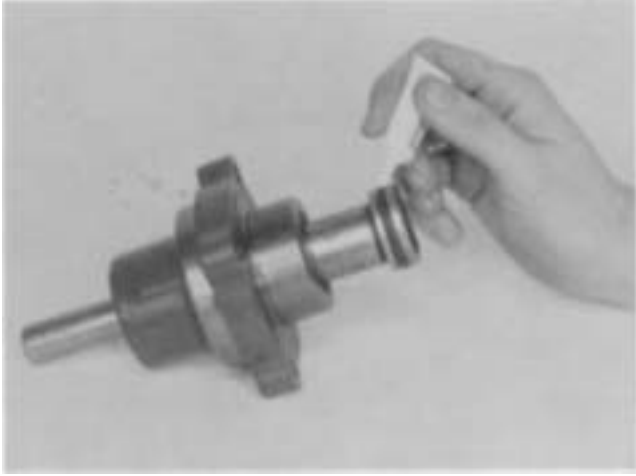

1. Replace inner O-ring on reduction cylinder and external O-ring on reduction yoke bar. Lube both O-rings with silicone lube and install yoke bar in cylinder,

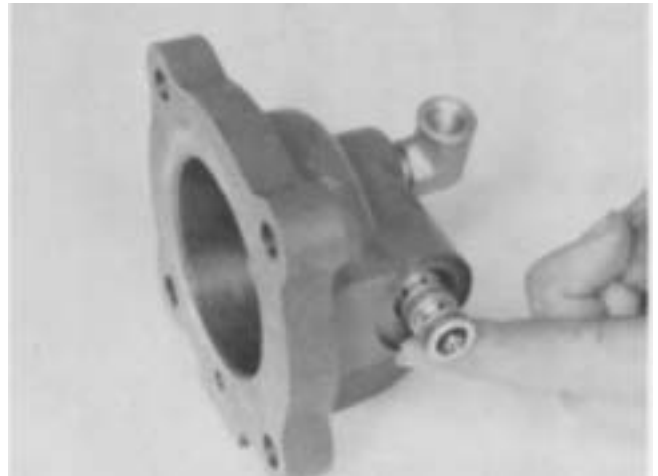

3. Install the insert valve into the cover with the tip pointing out.



2. Lube the O-rings on the insert valve with silicone lubricant.

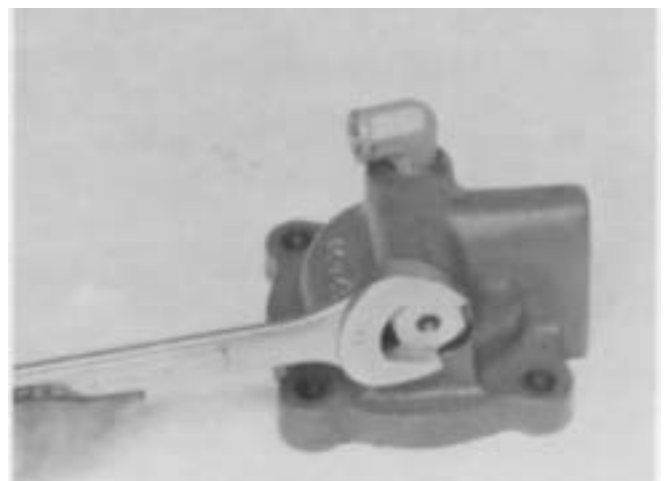

4. Reinstall the insert valve retaining nut.

REASSEMBLY - AUXILIARY SECTION

D. Low Range Gear Installation



5. Line up air hole in reduction cylinder body with hole in cover. Install a new gasket and match up the holes.
6. Install the reduction cylinder using a new gasket. Position the cylinder so the insert valve is at 6 o'clock.



1. Slide the low-low clutch part way onto the mainshaft, with the splined side toward the reduction gear.

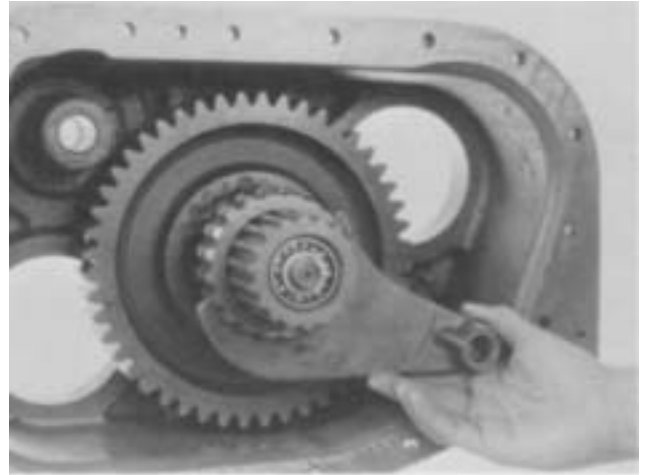

2. Mesh the shift yoke with the clutch and slide back onto yoke bar.

REASSEMBLY - AUXILIARY SECTION

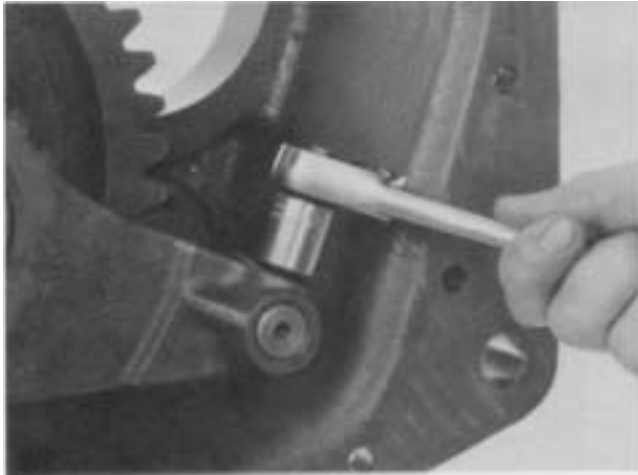

3. Install yoke capscrew and lockwire into place.



6. Install low range gear on mainshaft with machined surface facing machined surface on coupler.

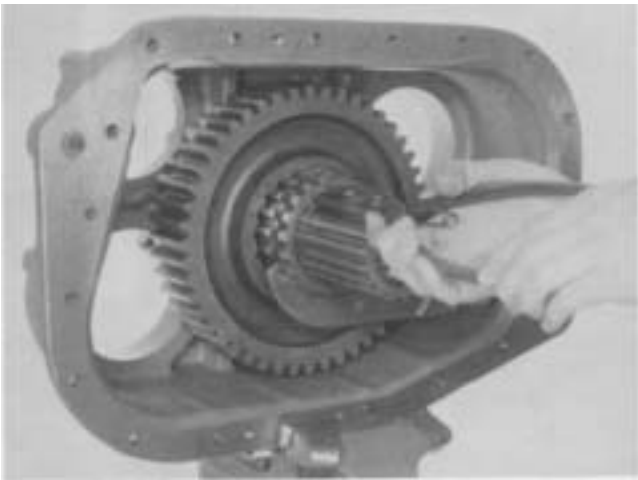

4. Install snap ring on mainshaft.

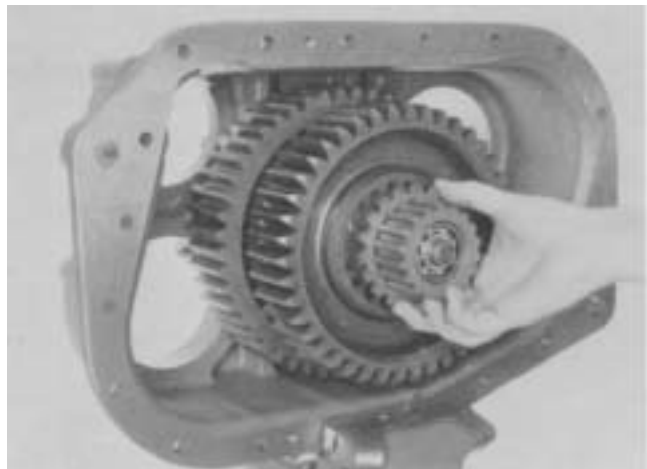

7. Install the spacer-tolerance washer with beveled teeth facing out, and mesh it inside the low range gear.

NOTE: Splined washers with varying thicknesses are available. Use the washer that provides the tightest fit in the hub of the gear.

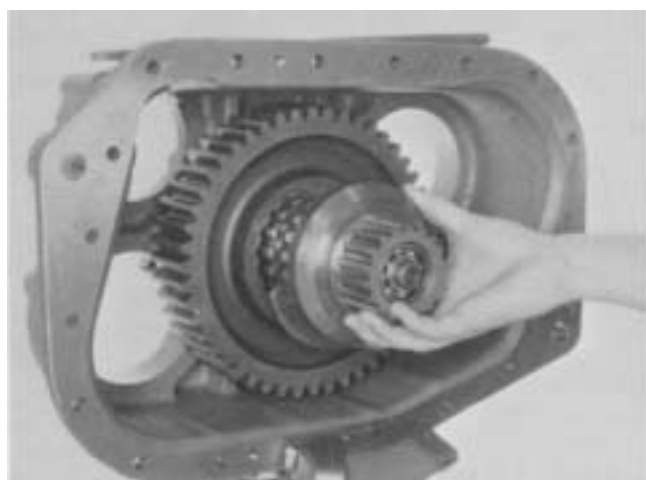

5. Install coupler, with clutching teeth to rear.

REASSEMBLY - AUXILIARY SECTION

E. Countershaft Installation

1. If previously removed, install the bearing inner race on front of each countershaft.



8. Rotate the spacer-tolerance washer to line up the square notch in the washer with the keyway in the range mainshaft. Install the key in the keyway, shoulder to rear.
9. If the synchronizer was disassembled, rebuild as detailed in low range auxiliary section.



2. Locate the stamped "O" on each countershaft gear. Mark the gear tooth directly above the "O" for timing purposes.

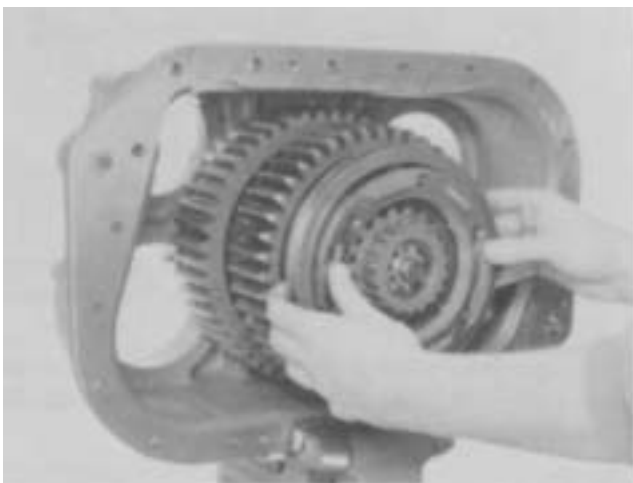

10. Slide the synchronizer into position on the mainshaft.



3. Install the countershaft bearings with a flanged driver.

REASSEMBLY - AUXILIARY SECTION

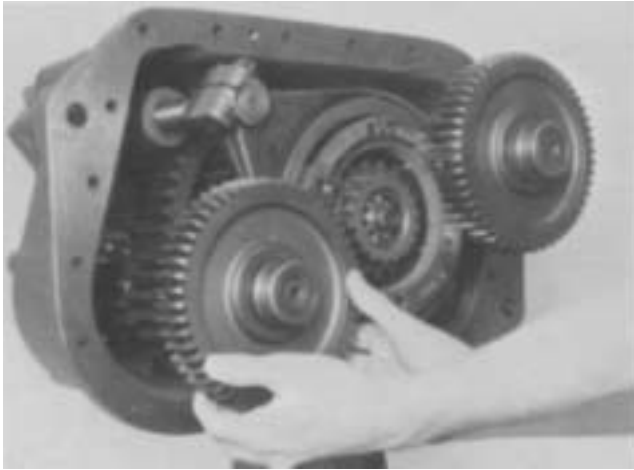

4. Mesh the marked tooth on each countershaft with the marked teeth on the reduction gear.
5. Drive the countershaft bearings fully into place in the housing.

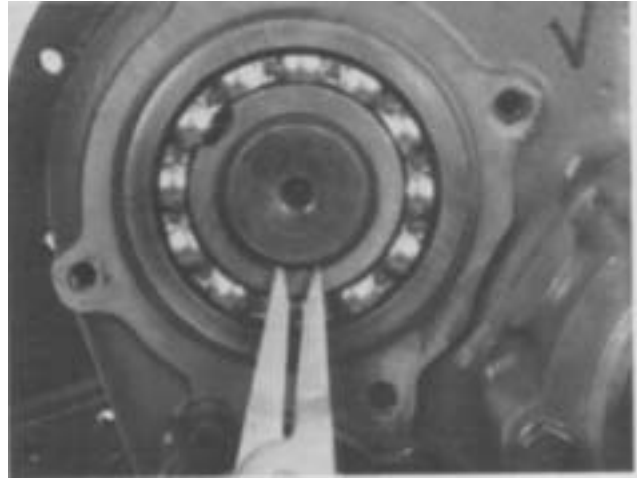

7. When the snap ring grooves are fully exposed, install the snap rings.

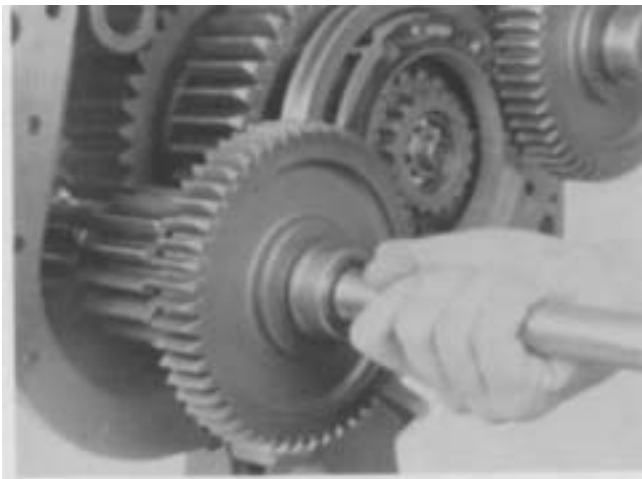

6. Temporarily install the countershaft bearing covers and use a soft bar and maul to drive the countershaft back into the bearing.

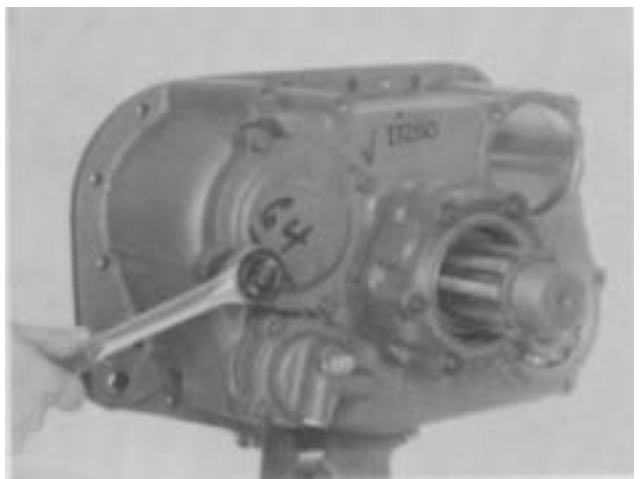

8. Install the bearing covers with new gaskets.

REASSEMBLY - AUXILIARY SECTION

F. Range Air System Installation

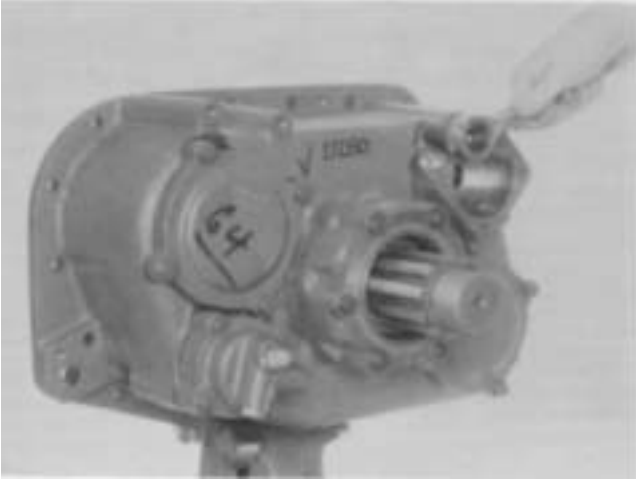

1. Install range shift air cylinder body.
2. If previously removed, install the O-ring in bore of range cylinder body.
3. Position the range yoke on the synchronizer.

5. Install the range yoke cap screws and lockwire.



4. Slide the range yoke bar through the range yoke and into the housing from the gear side.



6. Install range yoke piston with step to inside. Lube both internal and external O-rings with silicone before sliding into position.

REASSEMBLY - AUXILIARY SECTION

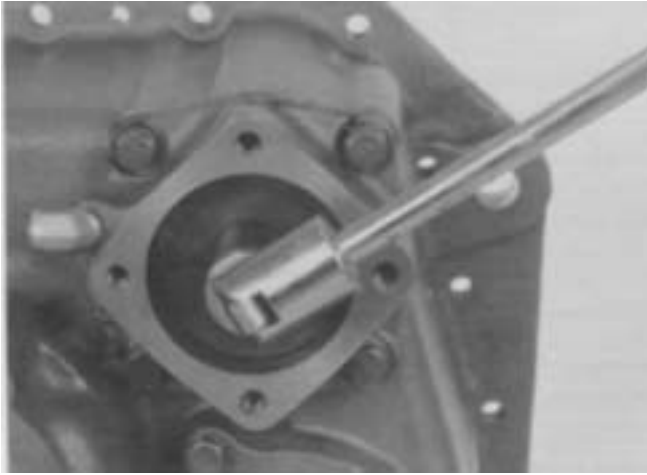

7. Install a new range yoke locking nut, torquing to 45 ft. lbs.



8. Install range cylinder cover with a new gasket.

DISASSEMBLY - FRONT SECTION

A. To Remove Input Shaft Nut

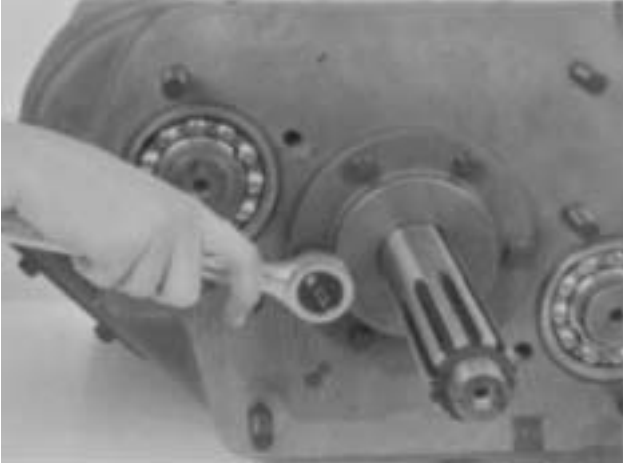

1. Turn out the capscrews and remove the front bearing cover. (Tap input shaft to loosen bearing cover seal.)

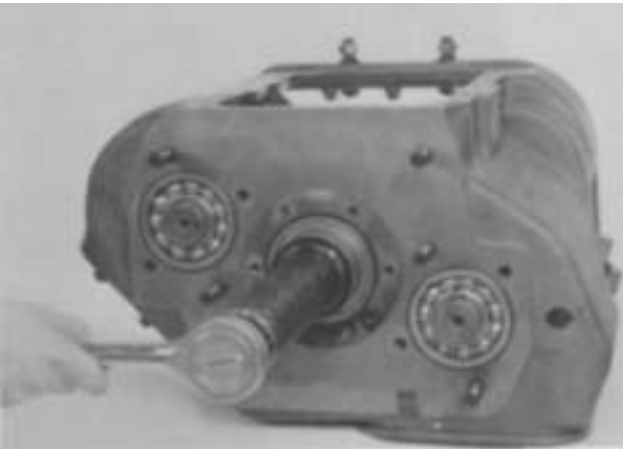

2. Engage two mainshaft sliding clutches into gear; this prevents transmission from rotating. Remove nut (left hand thread) with drive gear nut removing tool.

DISASSEMBLY - FRONT SECTION

CASE ASSEMBLIES

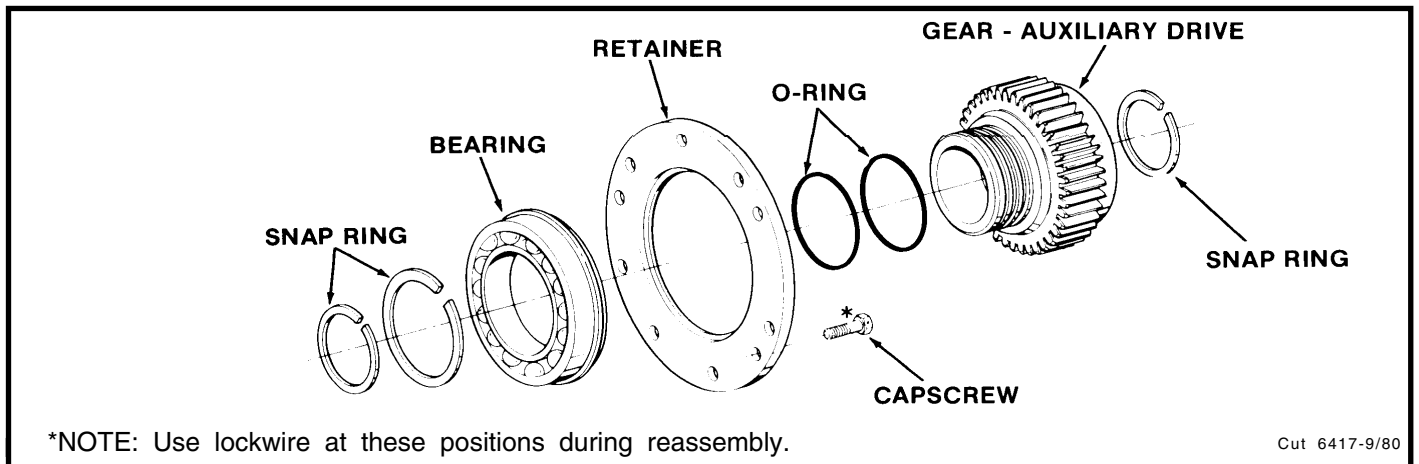

B. Removal and Disassembly of Auxiliary Drive Gear Assembly

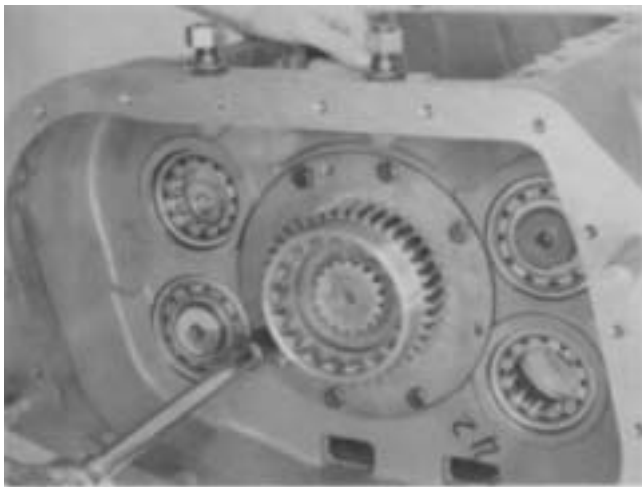

1. Cut the lockwire from the retainer plate capscrews and remove the capscrews

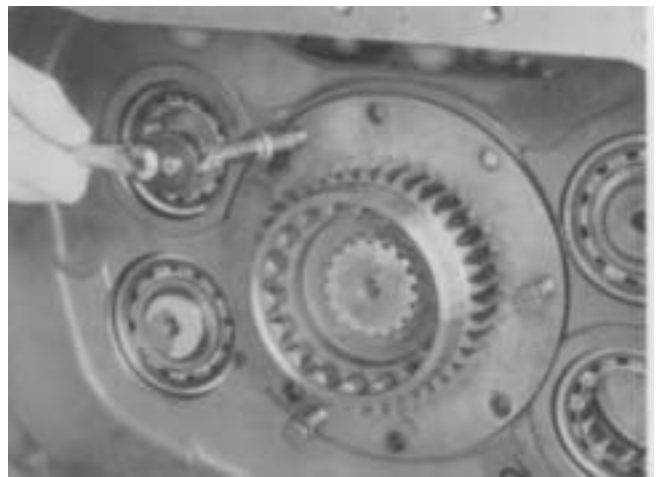

3. Insert the three puller screws into tapped holes of the retainer ring and tighten evenly to remove the drive gear assembly from the case bore.

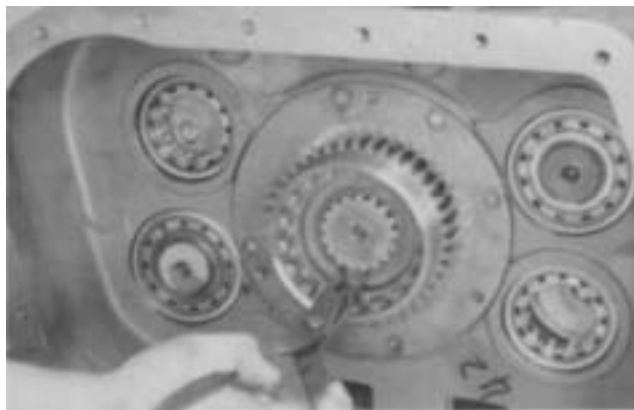

2. Remove snap rings from the two counter shafts and the mainshaft.

DISASSEMBLY - FRONT SECTION



4. Remove the snap ring from hub of auxiliary drive gear.



6. If necessary, remove the O-rings from hub O.D. of auxiliary drive gear.



5. Using the rear face of retainer ring as a base, press the drive gear through bearing.



7. Remove the inner snap ring from the mainshaft.

DISASSEMBLY - FRONT SECTION

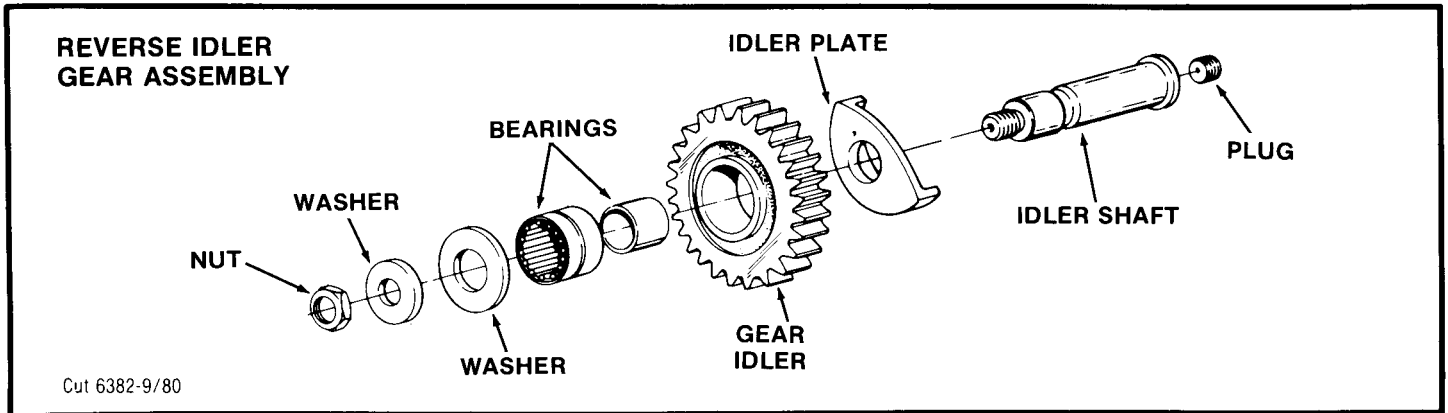

C. Upper Reverse Idler Gear Assembly Removal



1. Remove the upper reverse idler gear assembly locknut and washer.



3. Remove the reverse idler shaft plug to allow the puller tool to be installed in the end of the shaft.



2. Pull the front auxiliary countershaft bearing with a flanged slide puller.

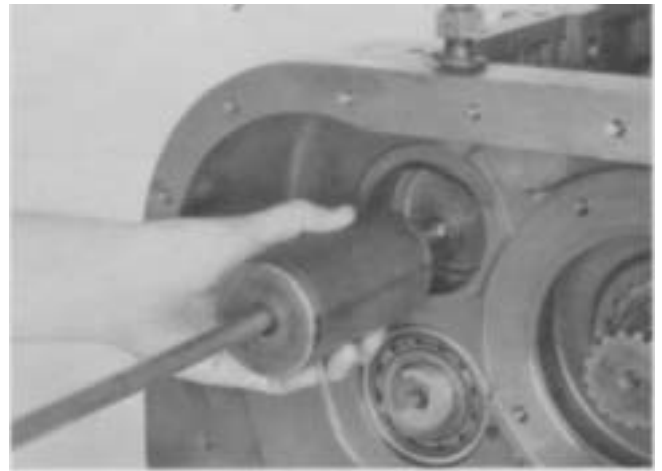

4. Install a threaded slide puller in the end of the shaft and pull the reverse idler shaft from the bore.

DISASSEMBLY - FRONT SECTION



5. Remove the snap ring from the inside of the reverse gear, allowing the gear to be slid forward on the mainshaft.



6. Lift out upper reverse idler gear and washer.

D. Upper Countershaft Assembly and Mainshaft Assembly Removal

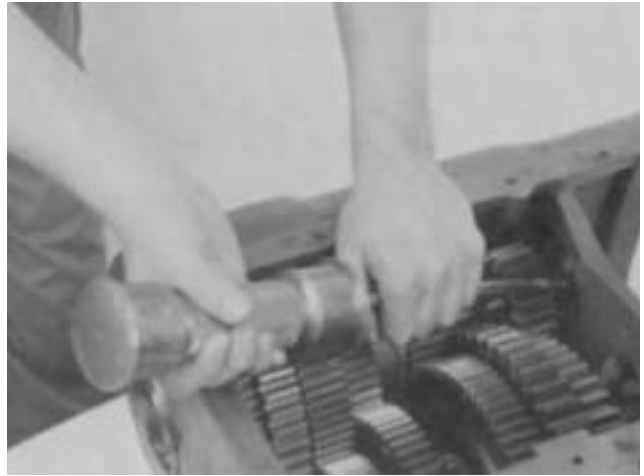

1. Remove the upper countershaft rear bearing by driving out with a soft bar and maul.

NOTE: Bearing will be damaged during this operation.



2. Remove the snap ring from the upper countershaft front bearing.

DISASSEMBLY - FRONT SECTION

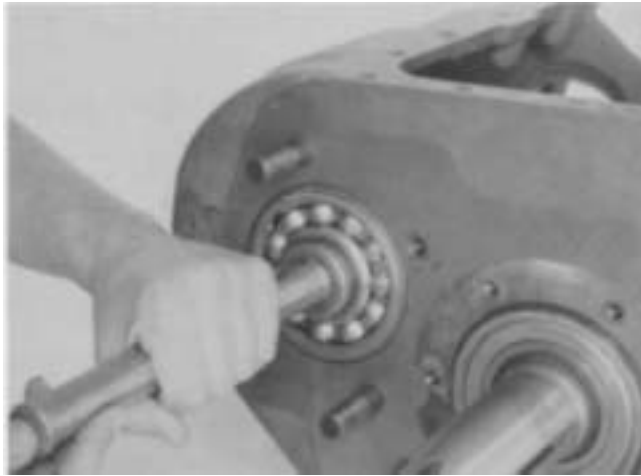

3. Drive the countershaft part way through the bearing with a soft bar and maul.

NOTE: Make certain that the reverse gear is up on the lower idler gear and is not hanging up during this operation.

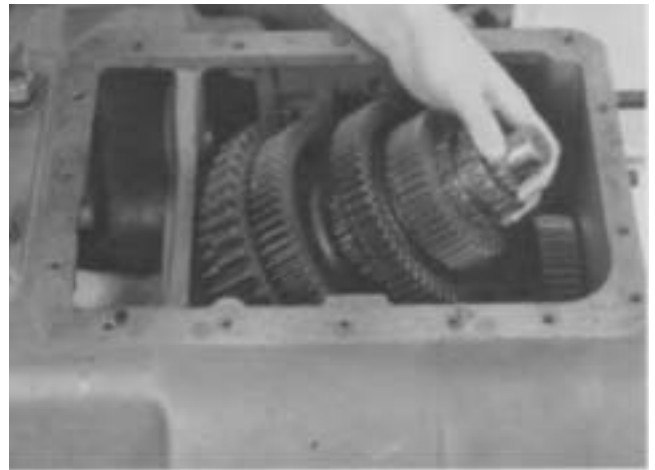

6. Support the reverse gear with one thumb from behind while lifting upon the mainshaft at the front clutch.

7. Support reverse gear on the auxiliary web, switch position of back hand and lift out mainshaft assembly.

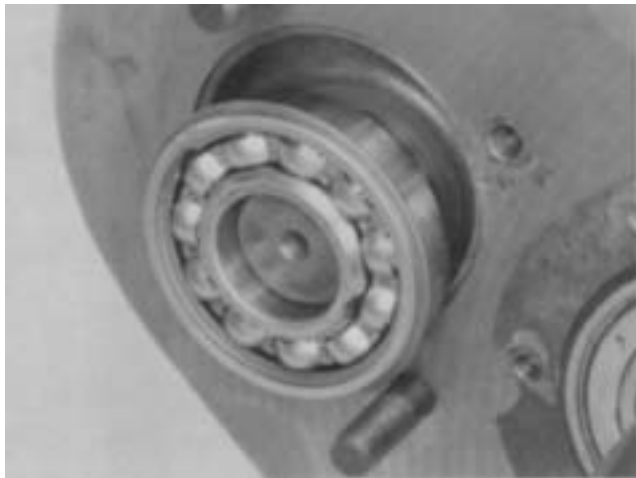

4. When the shaft is almost through, go to the back side and drive the shaft forward to remove the front bearing from the bore.

5. Remove bearing from shaft using bearing puller or pry bars, and remove upper countershaft toward case wall as far away from the mainshaft as possible.



8. Remove upper countershaft by sliding the shaft back, and tilting front up and out.

DISASSEMBLY - FRONT SECTION

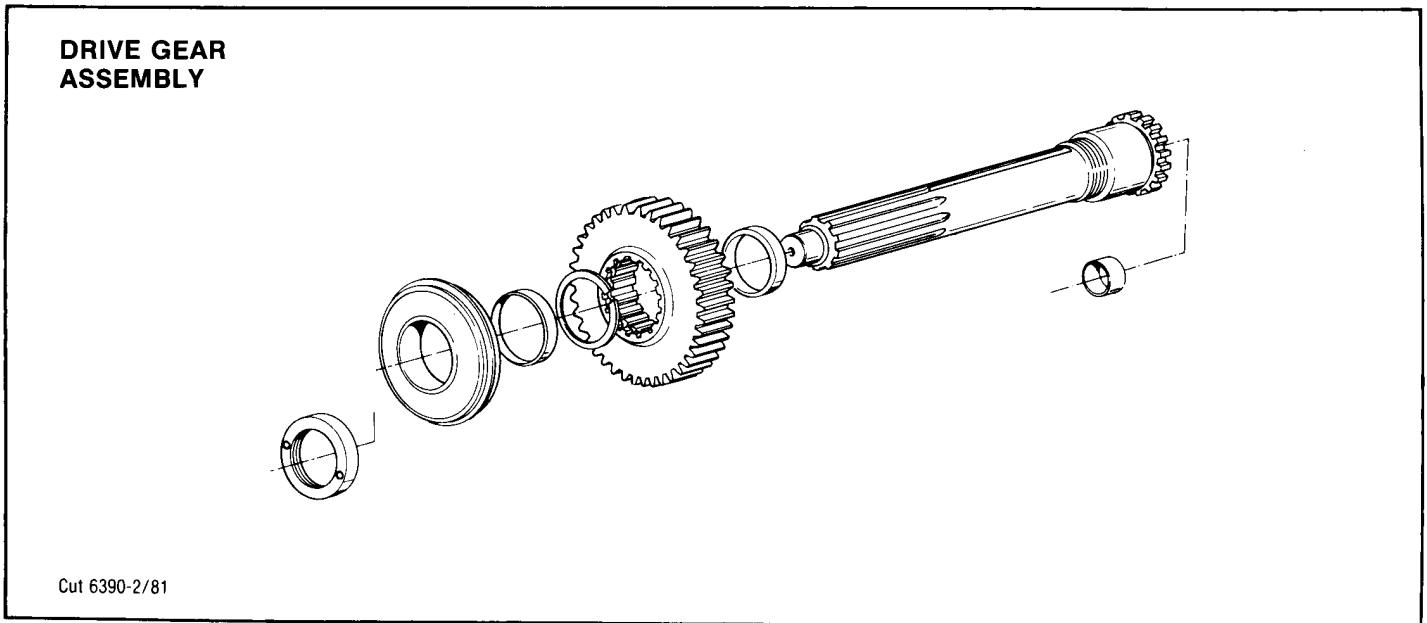

E. Lower Countershaft, Lower Idler Assembly and Input Shaft Assembly Removal



1. Drive the input shaft back through bearing with a soft bar and maul.
2. Lift input shaft and input drive gear from case.



3. Tap the input shaft bearing out the front of the case with a driver.
4. Remove the lower countershaft. Steps for removal are identical to upper countershaft removal.

NOTE: Make certain the countershaft are not mixed after removal. The upper countershaft has a 45 tooth PTO gear and the lower a 47 tooth PTO.

DISASSEMBLY - FRONT SECTION

5. Remove the lower reverse idler assembly. Steps for removal are identical to the upper idler assembly removal.

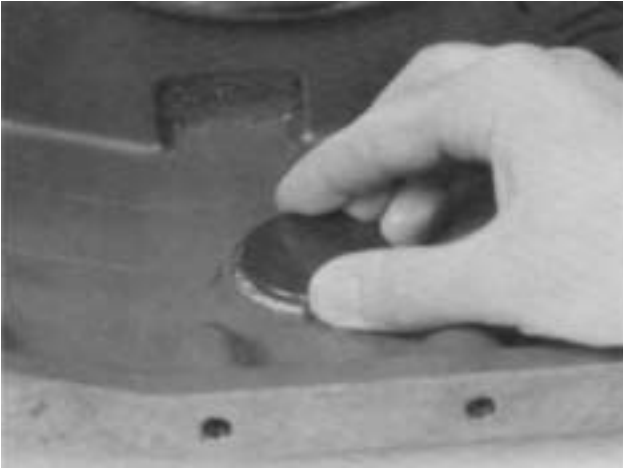

6. If any of the magnets in the bottom of the case were damaged during disassembly, chip them out and glue new magnets into place using Scotch Grip Rubber Adhesive or equivalent adhesive.

DISASSEMBLY - FRONT SECTION

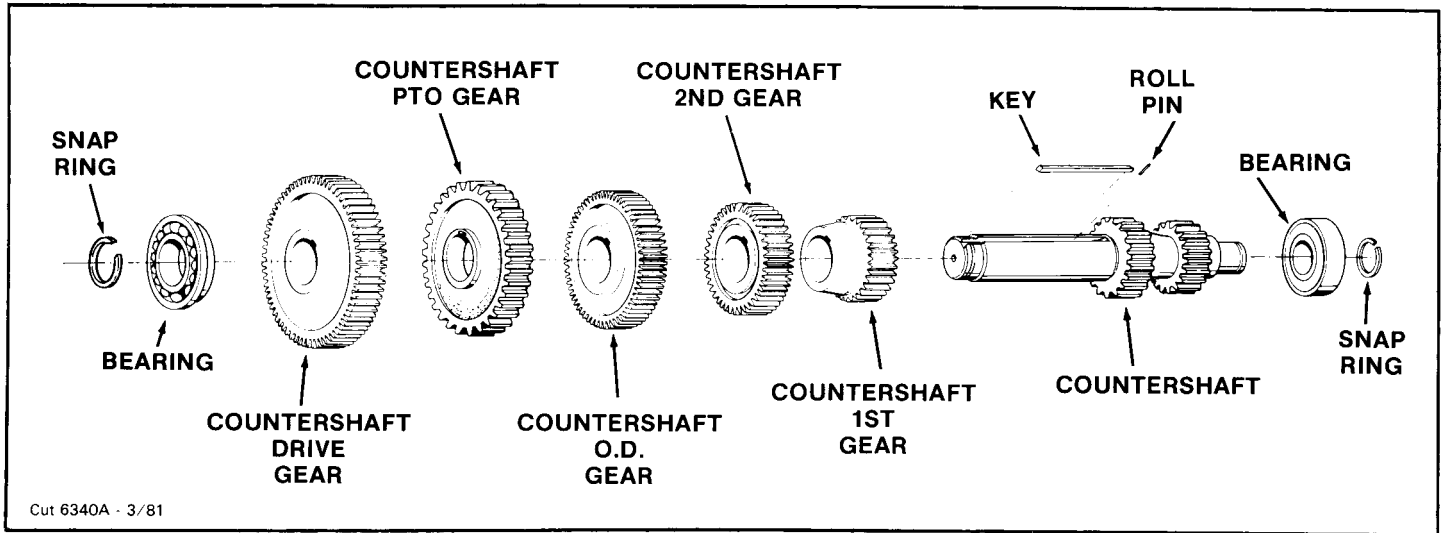

F. To Disassemble the Countershaft Assemblies

NOTE: Both countershaft are disassembled in the same manner, as construction is identical.

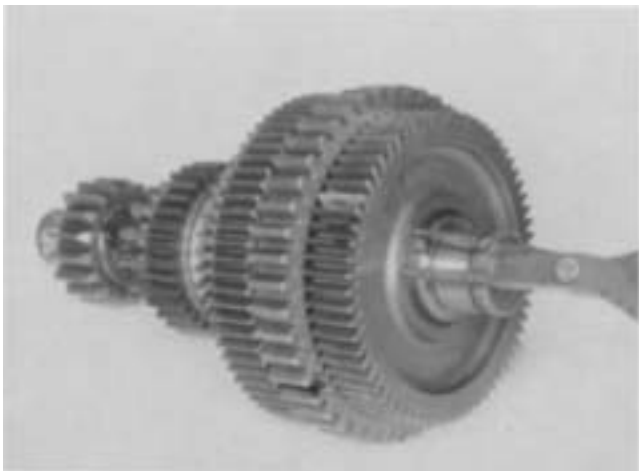

1. Remove snap ring from front of countershaft.



2. Press the drive ear, PTO and overdrive gear off the countershaft in one cluster.

NOTE: A press with a minimum of 20 tons will be necessary for this operation.

DISASSEMBLY - FRONT SECTION



3. Press off 2nd speed gear.



4. Press the 1st speed gear from the countershaft,
5. Remove the key and roll pin if replacement is necessary due to damage or excessive wear.

DISASSEMBLY - FRONT SECTION

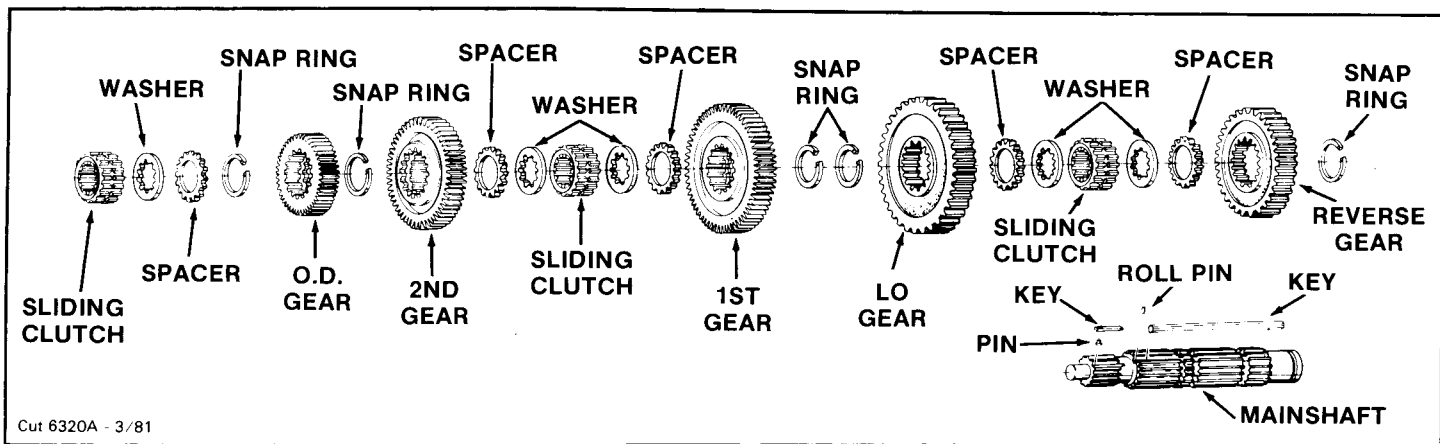

G. To Disassemble the Mainshaft Assembly



1. Remove the sliding clutch from the mainshaft.

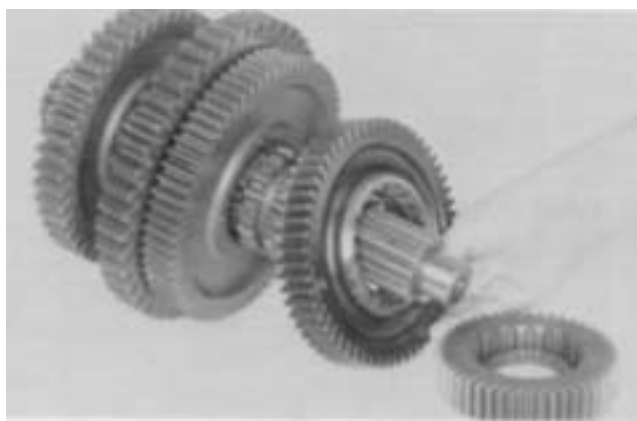

3. Rotate the tolerance washer to line up splines, and remove washer, spacer, overdrive gear and second gear.



2. Lift the short key out of the groove in the mainshaft.



4. Clamp the mainshaft in a vise with brass or soft jaws and withdraw the long key.

DISASSEMBLY - FRONT SECTION

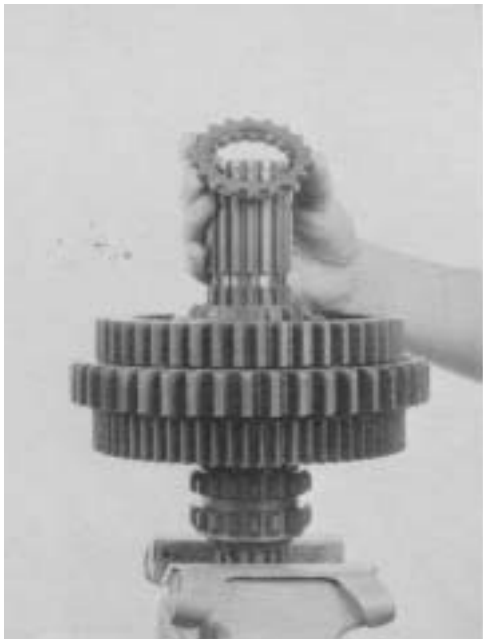

5. Remove the spacer and tolerance washer from mainshaft.



7. Remove low gear with tolerance washer and spacer.

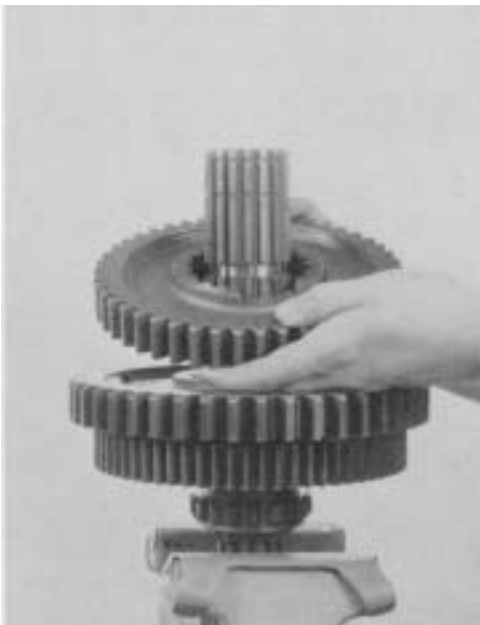

6. Remove reverse gear and reverse clutch.



8. Remove first gear with tolerance washer and spacer.

DISASSEMBLY - FRONT SECTION

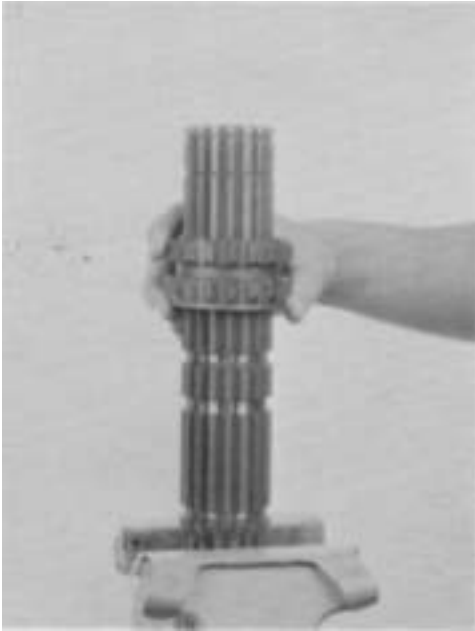

9. Lift the final sliding clutch and tolerance washer from the mainshaft.

REASSEMBLY - FRONT SECTION

A. Reassembly of the Countershaft Assemblies

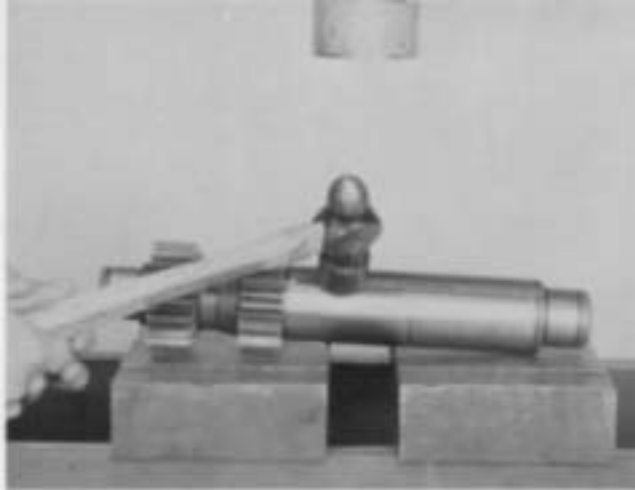

1. If previously removed, install the roll pin and long key in keyway of countershaft.



3. Press the second speed gear on countershaft, long hub of gear against first speed gear hub.



2. Align keyway in gear with key in countershaft and press first speed gear into position on shaft, long hub of gear toward front of countershaft.

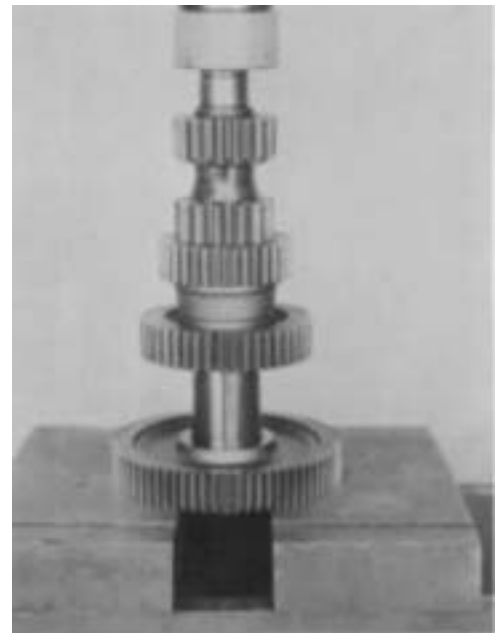

4. Press the overdrive gear on countershaft against second speed gear.

REASSEMBLY - FRONT SECTION



5. Press the power take-off gear on the countershaft with the bullet nose teeth against the overdrive gear.

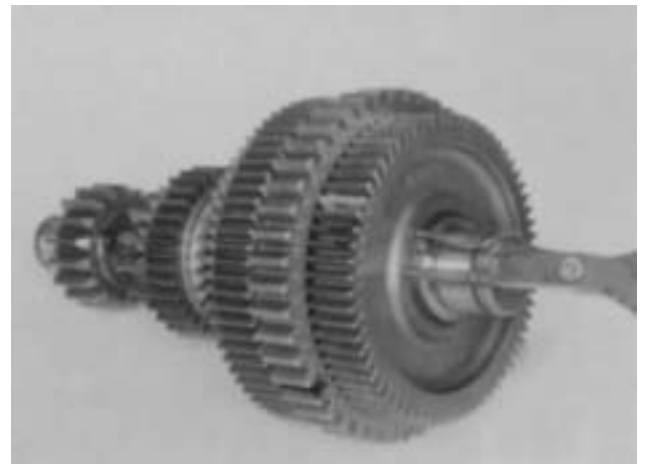

7. Reinstall the snap ring on the front of the countershaft.



6. Press the drive gear on the countershaft with the long nub facing the PTO gear.

REASSEMBLY - FRONT SECTION

B. To Reassemble the Mainshaft Assembly

1. Place the mainshaft in a brass or soft jawed vise with pilot end down.



2. Install a tolerance washer on the mainshaft with the step on the washer facing up. Rotate washer to locate in groove of mainshaft.

NOTE: The stepped side of tolerance washers always faces a clutch.

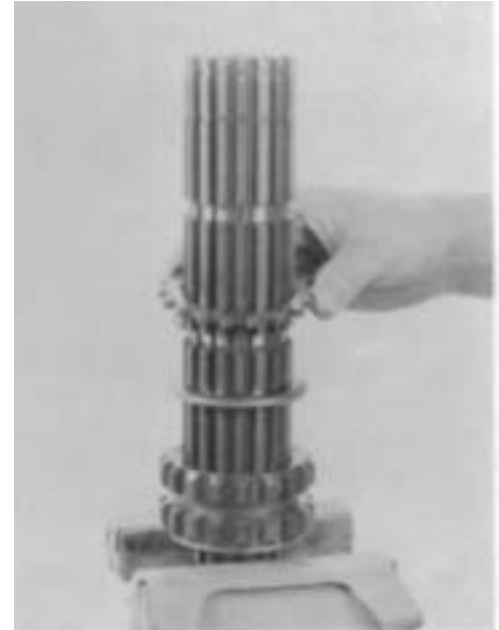

4. Install a tolerance washer with the flat side up, rotate washer to locate in groove. Install a spacer.
5. Temporarily install the key.



3. Locate the missing spline in a clutch, and install over the groove with the roll pin at the bottom.

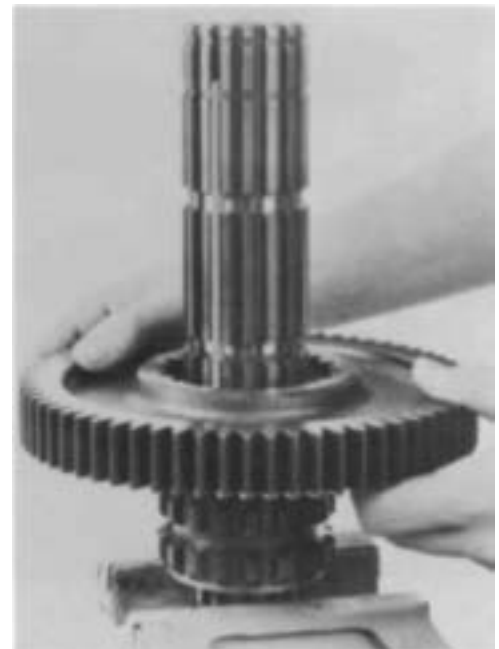

6. Install first gear with clutching teeth toward the clutch (flat machined surface facing up).

REASSEMBLY - FRONT SECTION

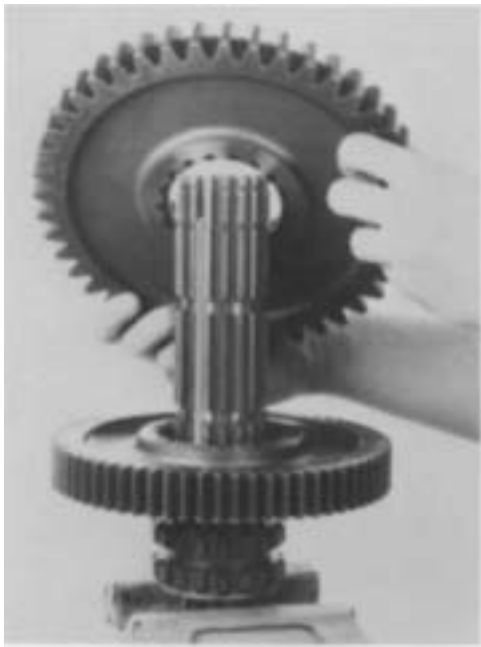

7. Install low gear with the machined surface facing down toward first gear.
8. Remove the key.



10. Rotate the tolerance washer to line up splines and install key.



9. Install a spacer and a tolerance washer with the stepped side of the tolerance washer facing up.



11. Check the clearance between low and first gear by lightly wedging the gears apart with two large screwdrivers and measuring the gap with a feeler gauge. The gap must be between .005" to .012".

REASSEMBLY - FRONT SECTION

12. Washers are available in the following thicknesses to obtain the correct limits.

.248 -.250
.253 -.255
.258 -.260
.263 -.265
.268 -.270
.273 -.275

Refer to Illustrated Parts Lists for washer part numbers.

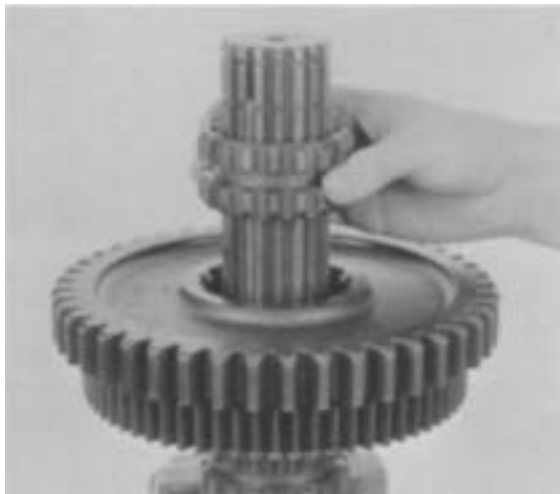

13. Install a clutch with the missing internal spline of the clutch aligned over the key.



14. Temporarily remove the key and install the tolerance washer with the step down and a spacer.

15. Rotate the tolerance washer to line up splines and reinstall the key.



16. Temporarily install the internal snap ring in the reverse gear, and install the reverse gear with the clutching teeth facing down.



17. Install the mainshaft snap ring.

REASSEMBLY - FRONT SECTION

NOTE: Because the auxiliary drive gear assembly is used in checking reverse gear axial clearance, it must be reassembled before continuing mainshaft reassembly.



18. If previously removed, install the O-rings on extended front hub of auxiliary drive gear.



20. Start the auxiliary drive gear bearing on front hub, bearing snap ring facing groove in retainer ring. Using both the inner and outer race of bearing as a base, press the bearing on gear with snap ring in groove of retainer ring or use a bearing driver (inset).

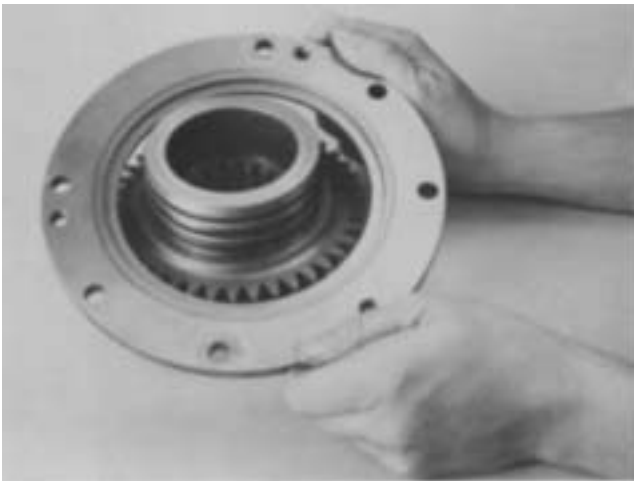

19. Install the retainer ring on auxiliary drive gear snap ring groove facing front hub and away from gear teeth.



21. Install the snap ring in groove of front gear hub to retain bearing.

REASSEMBLY - FRONT SECTION

22. Temporarily install the auxiliary drive gear on the mainshaft with the clutching teeth facing up.



23. Apply slight downward pressure on the auxiliary drive gear and reverse gear, and check the clearance between the two gears with a feeler gauge.

24. Clearance can be adjusted by replacing reverse gear splined washer with a different thickness washer. Proper clearance at this location should be .005" to .012".

25. Remove the auxiliary drive gear and reverse gear.

26. Remove the internal snap ring from reverse gear. (This is necessary for mainshaft installation.)

27. Remove the mainshaft from the vise and install with pilot end up. Install a spacer on the mainshaft.



28. Install second gear with the clutching teeth down. (Machined surface facing up.)

REASSEMBLY - FRONT SECTION



29. Install overdrive gear with the clutching teeth facing up.

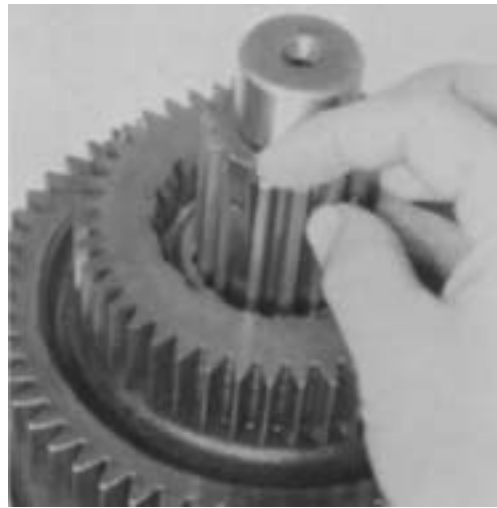

31. Install the short key in the keyway.



30. Install a spacer in the overdrive gear. Install a tolerance washer with the stepped side facing up, aligning the square internal notch of the tolerance washer with the keyway in the mainshaft.



32. Check the clearance between the second and overdrive gears by placing two large screwdrivers between the gears. Apply light downward pressure on the screwdrivers, and measure the gap between the gears with a feeler gauge.
33. The clearance between the gears must be between .005" and .012". Adjust in the same manner as low and first gear.

REASSEMBLY - FRONT SECTION

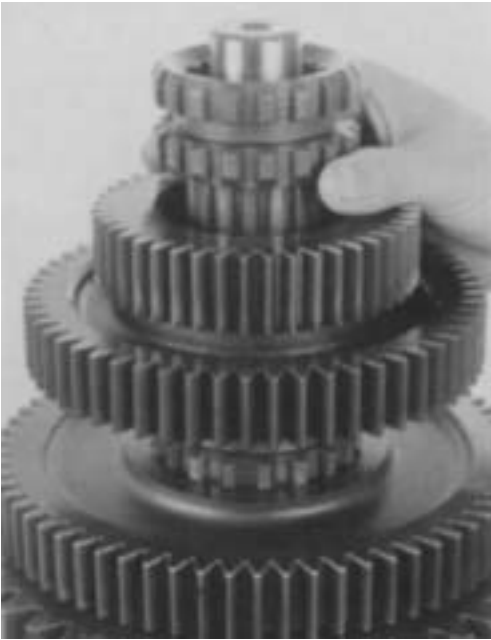

34. Install the sliding clutch.
35. Remove the mainshaft assembly from the vise.

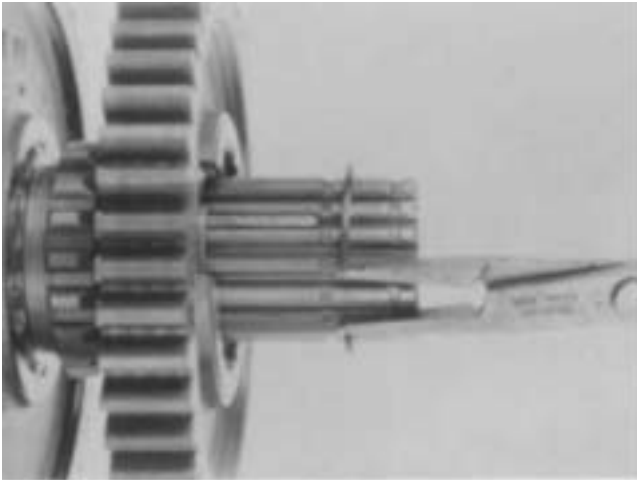

36. Install the reverse gear (without internal snap ring) and the mainshaft snap ring if previously removed.

REASSEMBLY - FRONT SECTION

C. Lower Countershaft Installation

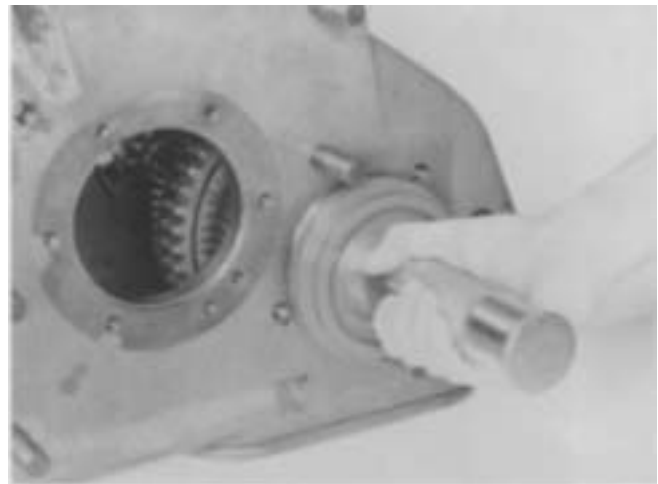

1. Before beginning installation, mark the gear tooth directly above the keyway on both countershaft for timing purposes. This tooth will be identified by an "O" that is stamped on the front of the tooth.

3. Install the front bearing (snap ring to outside) into the case and onto the countershaft using a flanged driver.

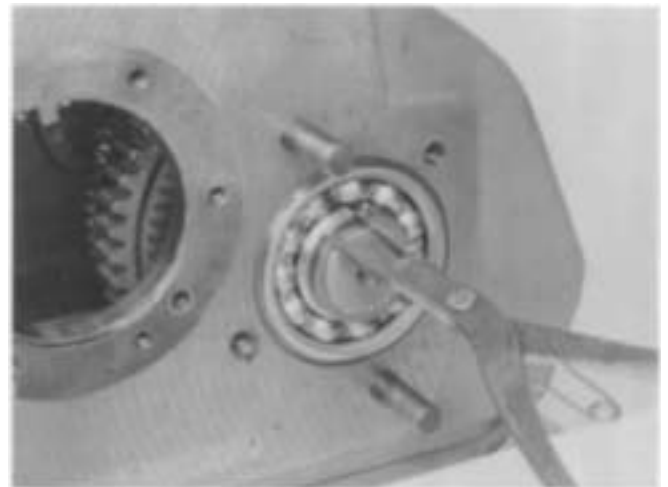
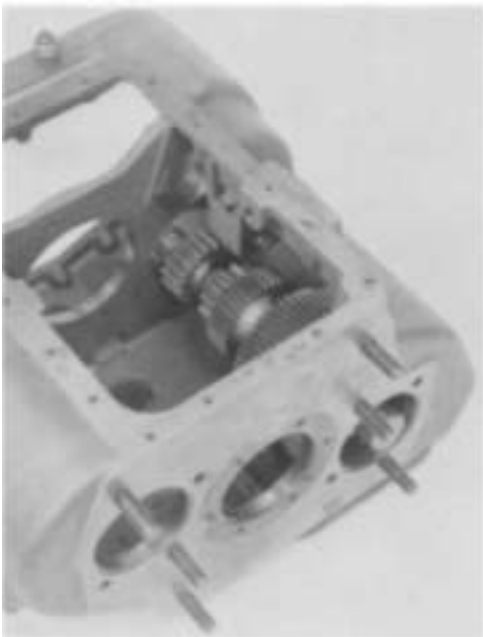

2. Position the lower countershaft (47 tooth PTO gear) in the front section.

4. When the snap ring groove is fully exposed, install the snap ring on the countershaft.

REASSEMBLY - FRONT SECTION

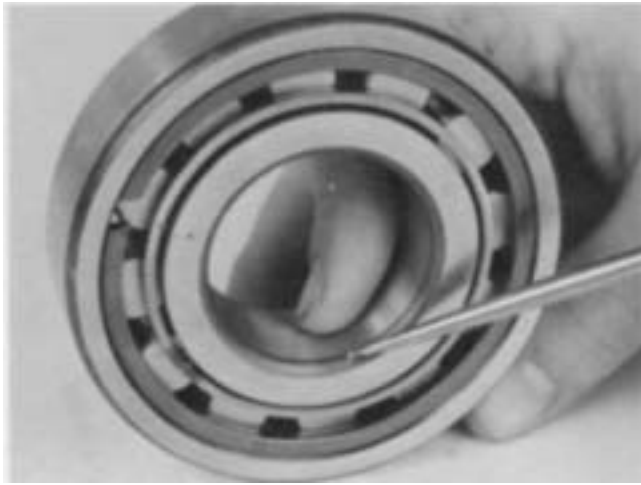

5. Position the rear countershaft bearing with the chamfered side of the inner race toward the inside.



7. Install the snap ring on the countershaft when the groove is fully exposed.
8. Tap on the drive gear end of the countershaft with a soft bar and maul, to make certain both bearings are fully seated.

D. Lower Reverse Idler Gear Installation



6. Drive the new rear bearing in with a flanged driver.



1. Press the inner needle bearing and race into the reverse idler gear, if they were removed.

REASSEMBLY - FRONT SECTION

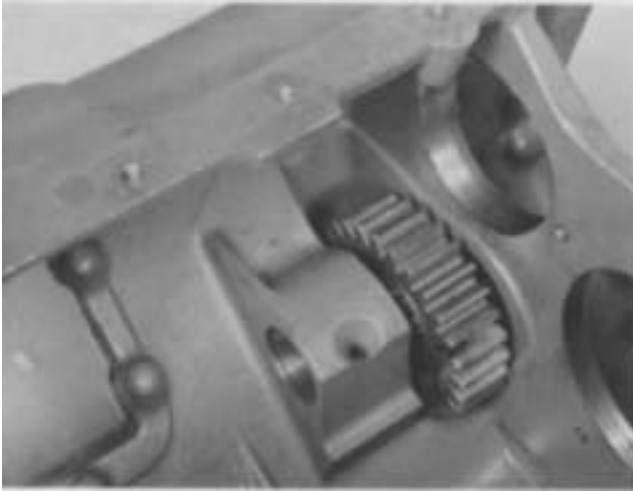

2. Position the idler gear in the case with the long hub toward the front of the transmission.



5. Drive the shaft back into the boss with a soft bar and maul.

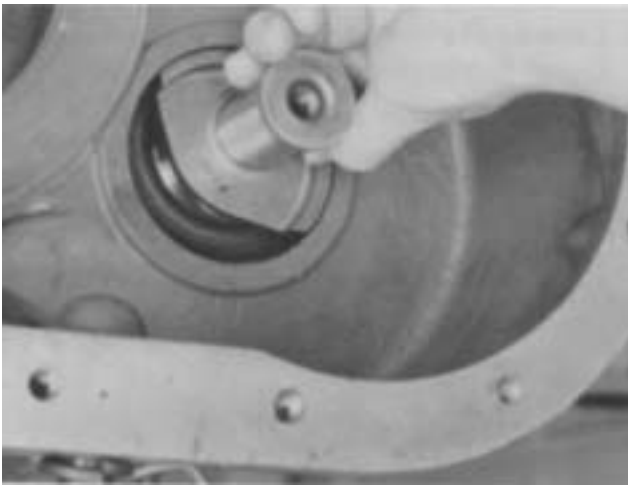

3. Start the shaft, with half moon washer installed, partway into the gear.

4. Position the flat washer between the gear and boss, and install the shaft completely into the boss.

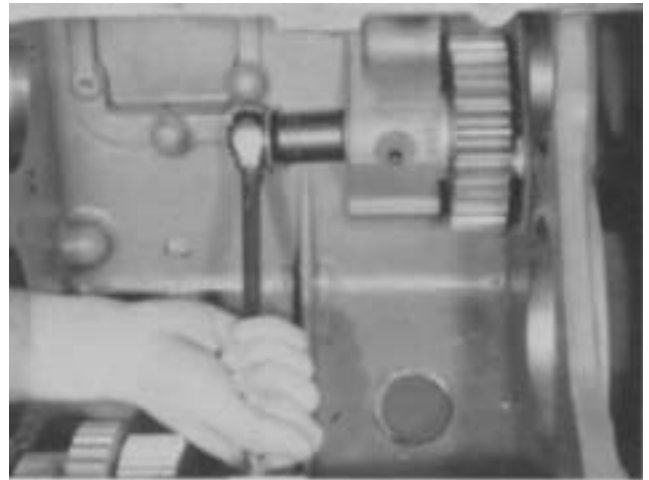

6. Install the washer and locknut on the shaft and tighten securely. Check the gear for free rotation after tightening nut.

REASSEMBLY - FRONT SECTION

E. Input Drive Gear Assembly Installation

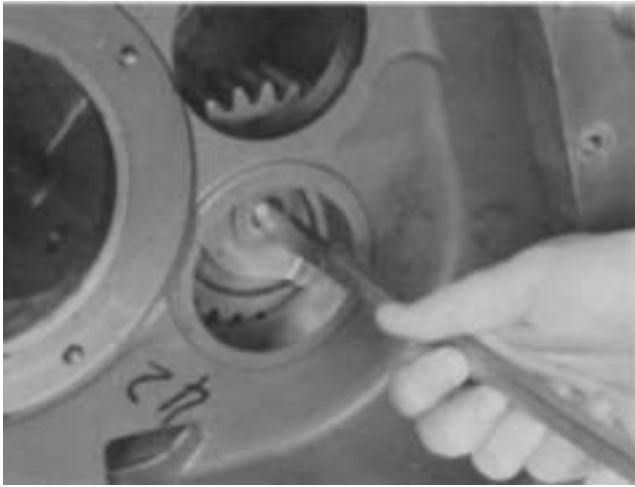

7. Install the plug in the end of the shaft.



8. Install the auxiliary bearing with a driver until the bearing bottoms against idler shaft retainer,

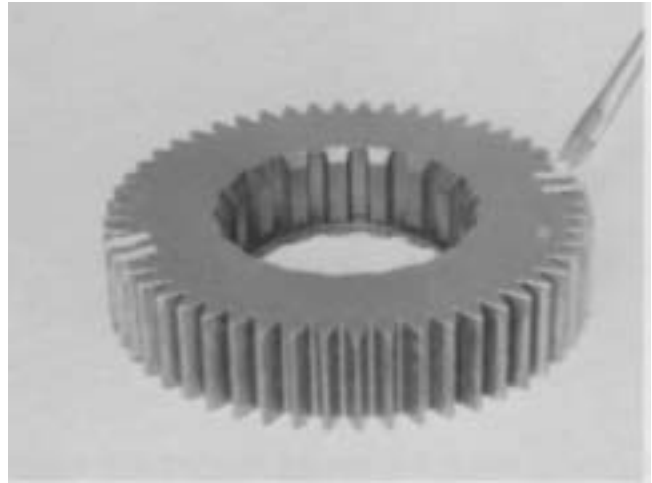

1. Paint any two adjacent teeth of the main drive gear and then paint the two teeth directly opposite.

2. Install the inner bushing in the input shaft if removed.



3. Install the main drive gear (snap ring toward case) and input shaft, meshing the marked teeth with the marked tooth on the lower countershaft.

4. Slide the input shaft through the main drive gear.

REASSEMBLY - FRONT SECTION

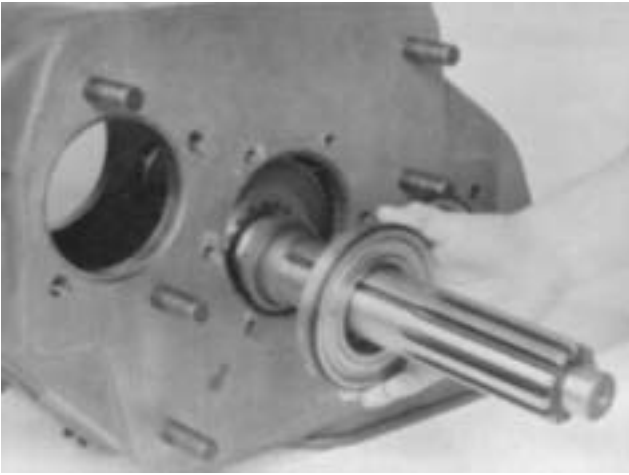

5. Install spacer and bearing on shaft with external snap ring to the outside.

NOTE: If a flanged driver of the correct length is available, it can be used to install the bearing. If the driver is unavailable, follow steps 6 through 8.



8. Use a long bar and maul to drive the input shaft out through the bearing from the inside of the case.
9. Remove the front bearing cover.

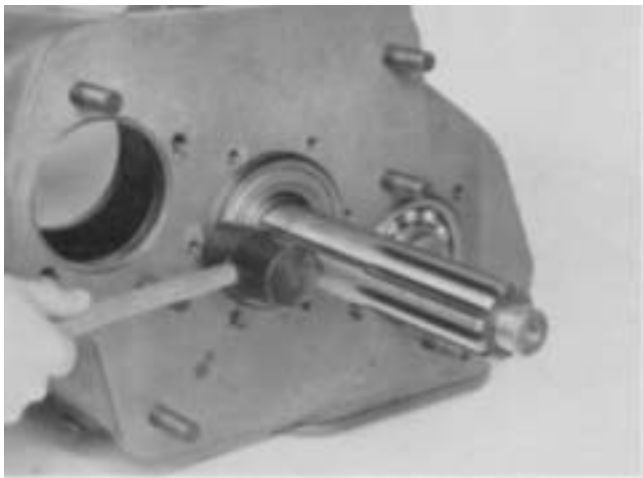

6. Tap the bearing into position in the bore with a soft mallet.
7. Temporarily install the front bearing cover.

REASSEMBLY - FRONT SECTION

F. Mainshaft Assembly and Upper Countershaft Installation

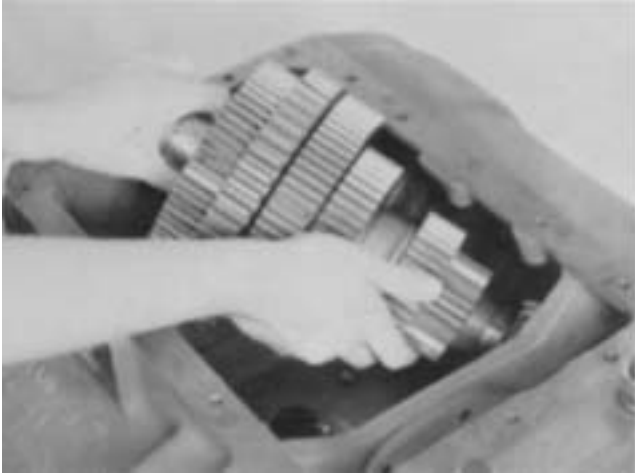

1. Lower the upper countershaft assembly into position in the case.
2. Rotate the countershaft until the timing tooth is close to the marked teeth on the main drive gear.

4. Lower the mainshaft assembly into position, reverse end first.

CAUTION: Support the reverse gear to prevent it from dropping and causing injury.



3. Pry the countershaft away from the drive gear as far as possible with a large screwdriver.

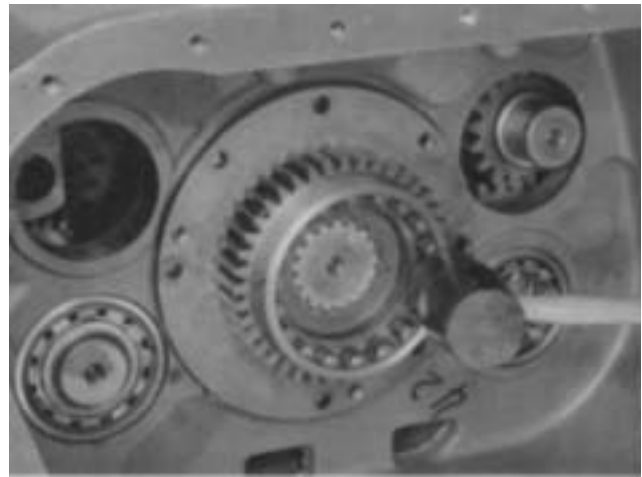

5. Use a soft mallet to temporarily install the auxiliary drive gear assembly. Seat it part way into the bearing bore to hold the mainshaft in position.
6. Check to make sure the timing marks are still properly in mesh between the lower countershaft and the main drive gear.

REASSEMBLY - FRONT SECTION

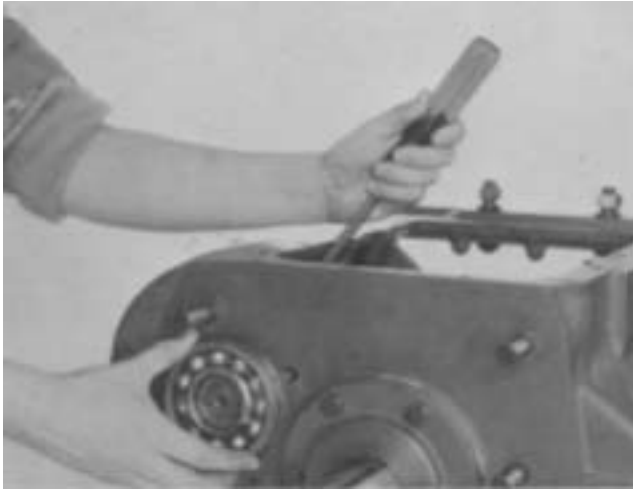

7. Remove the screwdriver wedging the upper countershaft and rotate the countershaft until the timing tooth is meshed correctly with the drive gear timing teeth.
8. Install the front and rear countershaft bearings, following the same sequence used when installing the lower countershaft bearings.



9. Remove the auxiliary drive gear assembly. Do not let the mainshaft move to the rear when removing auxiliary drive gear.

10. Install the upper reverse idler gear assembly following the same sequence as used for the lower reverse idler.



11. Slide the reverse gear back into position and install the snap ring in the gear.

REASSEMBLY - FRONT SECTION

G. Auxiliary Drive Gear Installation

1. Reinstall auxiliary drive gear assembly.

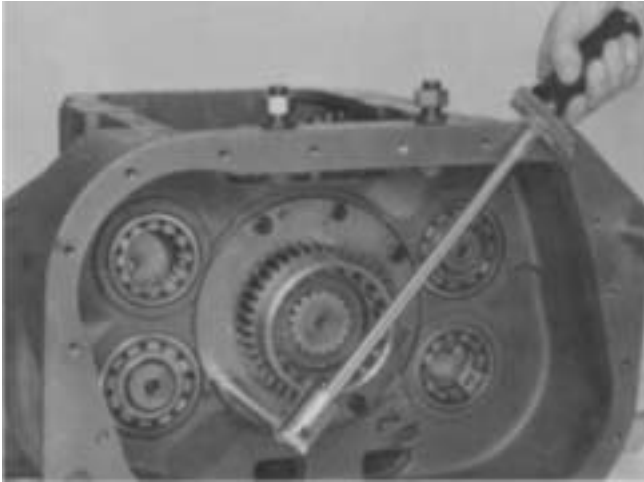

2. Install the capscrews holding the auxiliary drive gear to the case, and torque to specifications.



4. Install rear snap ring on mainshaft.
5. Check that the gear assemblies all spin freely, and engage all clutches to check that the unit is timed correctly.

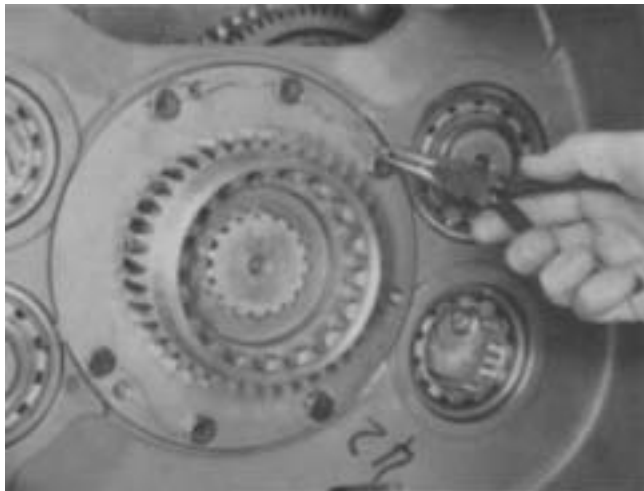

3. Lockwire the capscrews.

REASSEMBLY - FRONT SECTION

H. Drive Gear Nut and Bearing Cover Installation

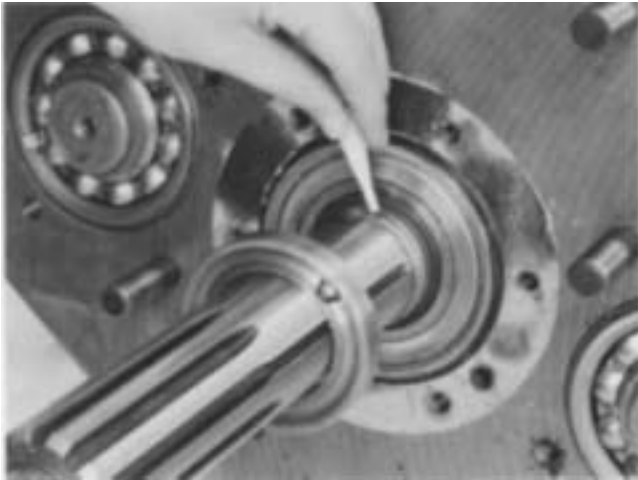

1. Apply loctite grade 277 sealant and install a new drive gear nut and torque to 250-300 lbs. ft. of torque using a drive gear nut installer. DO NOT REUSE OLD NUT.

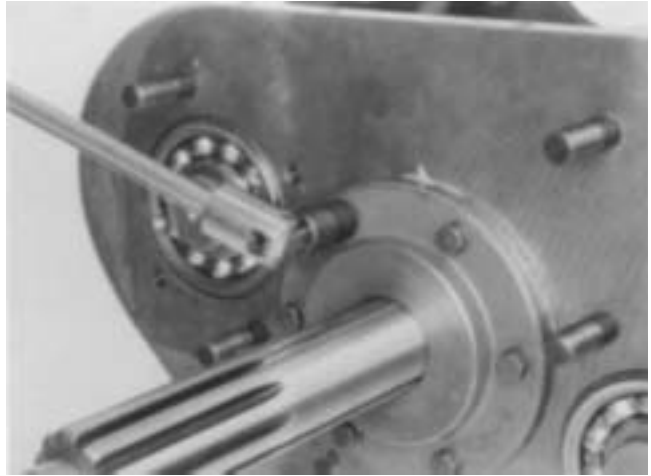

- 3 Install the bearing cover using a new gasket and aligning the oil return slot in the cover with the hole in the case.

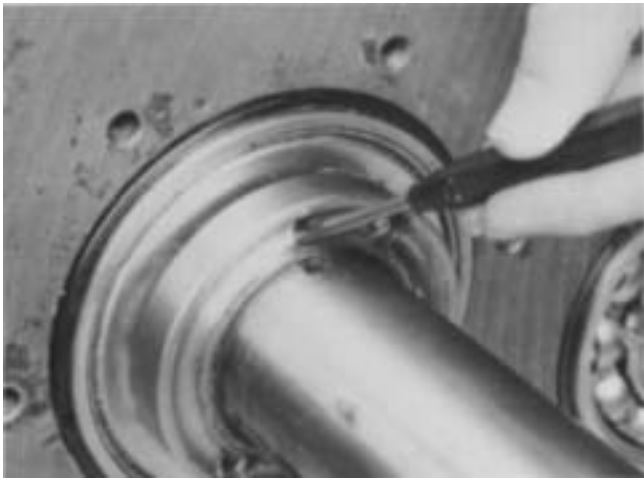

2. Stake the nut into the two milled slots of the input shaft with a staking tool or a punch and maul.

INSTALLATION - COMPANION FLANGE, AUXILIARY SECTION AND CLUTCH HOUSING

A. Clutch Housing Installation

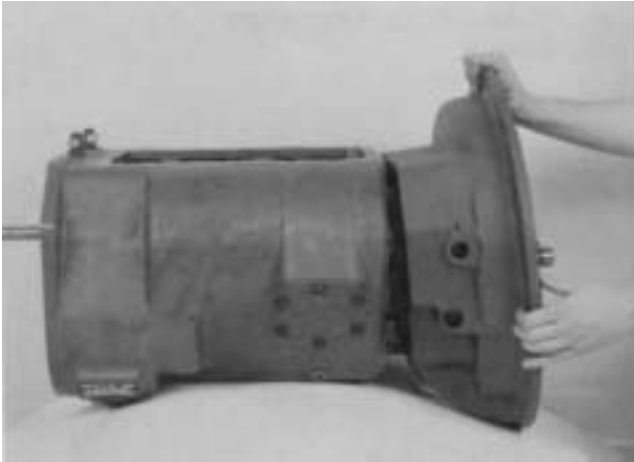

1. Position the corresponding new gasket on housing mounting surface and install the clutch housing on front case, piloting on the six studs and drive gear bearing cover.
2. Install the six nuts with washers or lockwashers on studs and tighten. See TORQUE RECOMMENDATIONS.
3. Install the four capscrews with lockwashers and tighten. See TORQUE RECOMMENDATIONS.

B. Auxiliary Section Installation



1. Install a new auxiliary mating surface gasket. Lower the auxiliary section into position with a hoist and align on the dowel pins.

NOTE: When installing a low-low auxiliary, the deep reduction clutch must be moved to the rear, engaging the deep reduction gear.



2. Slide the auxiliary part way onto the dowels, and remove the lifting eye.
3. Slide the auxiliary the rest of the way into position. It may make assembly easier if someone slowly rotates the input shaft during installation.
4. Fasten the auxiliary to the front section, drawing the capscrews down evenly. See TORQUE RECOMMENDATIONS.

C. Companion Flange Installation

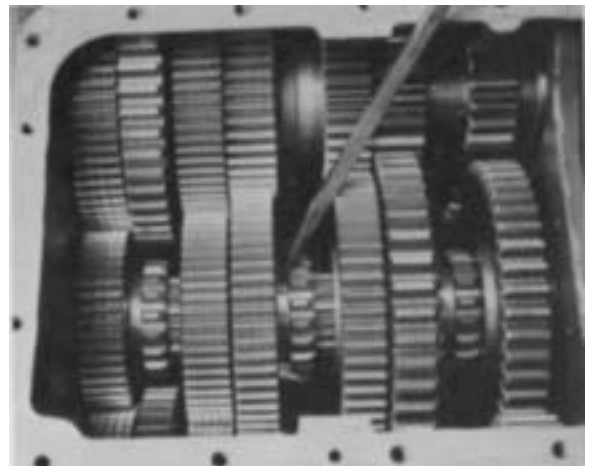

1. Lock the transmission by engaging two gears with the mainshaft sliding clutches.

INSTALLATION - COMPANION FLANGE, AUXILIARY SECTION AND CLUTCH HOUSING



2. Slide the companion flange or yoke onto the output shaft.

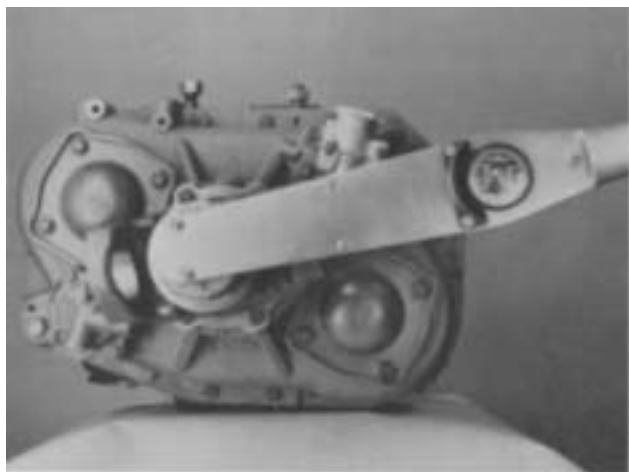

3. Install the output shaft nut and washer, torquing to 450-500 ft. lbs.

INSTALLATION - SHIFTING CONTROLS

SHIFT BAR HOUSING ASSEMBLY

A. Installation



1. Make sure the shift bars are in the neutral position.



4. Install the shifting bar housing on transmission, fitting yokes into slots of corresponding clutch gears.

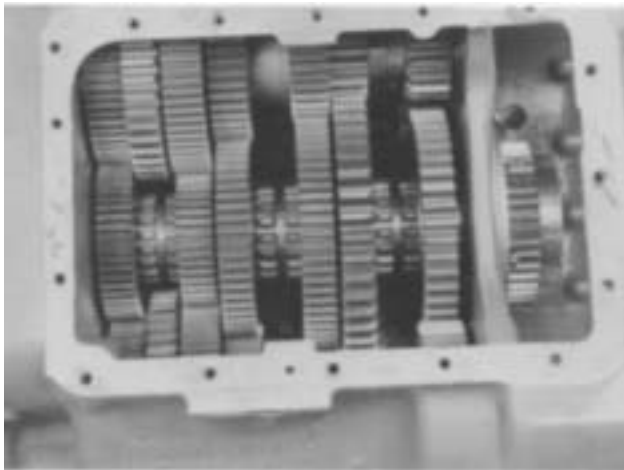

2. Place the sliding clutches on the mainshaft in the neutral position.

3. Install a new shift bar housing gasket in position on the case.



5. Install the attaching capscrews; tighten securely.

INSTALLATION - SHIFTING CONTROLS

GEAR SHIFT LEVER HOUSING ASSEMBLY

A. Installation



1. Make certain the three tension springs and balls are in the shift housing bores and install the gear shift lever housing and gasket on the shift bar housing, fitting the lever into shift block and yoke notches.



2. Install the four cap screws and tighten securely.

INSTALLATION - SHIFTING CONTROLS

AIR SYSTEM - RTO-11607L

A. Installation of Slave Valve

NOTE: For air line routing on transmissions equipped with a different combination of control valve and slave valve, see air schematics on pages 35 to 37.



1. Install the actuating pin and spring in bore in transmission.
2. If previously removed, install the fittings on the slave valve.



4. Install the slave valve on transmission using a new gasket. Tighten capscrews evenly and securely. Actuating plunger in case fits into alignment sleeve in slave valve.



3. Make sure the alignment sleeve is installed in the slave valve.

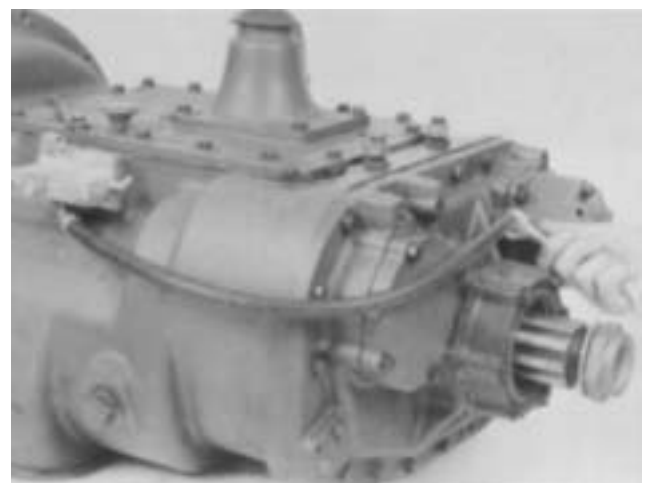

1. Install the low range airline between the "L" port on the slave valve and the air port in the body of the range cylinder.

B. Installation of Air Lines and Regulator

INSTALLATION - SHIFTING CONTROLS



2. Install the high range air line between the "H" port on slave valve and the air port in the cover of the range cylinder.

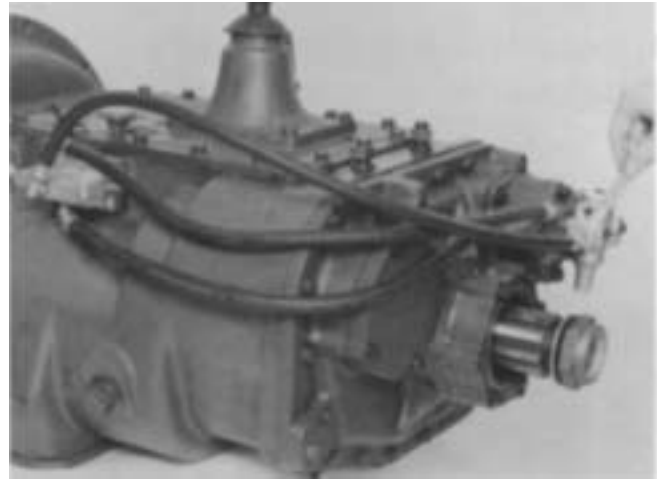

4. Install the air line between the air regulator and the "S" port of slave valve.

C. Master Control Valve Installation



3. Install the air regulator and filter assembly on mounting surface on the range cylinder cover; tighten capscrews securely.



1. Install the master control valve on the gear shift lever.
2. If air lines are to be replaced, measure lines and sheathing for correct length.

INSTALLATION - SHIFTING CONTROLS

3. Install sheathing on lines and draw under shroud on lever.



4. Connect the black nylon air line to the "S" port on the master control valve, and the white nylon line to the "P" port.

6. Install the white nylon air line from the "P" port of the control valve to the "P" port in the slave valve.



5. Install the black nylon air line from the "S" port of the control valve to the "S" port in the slave valve.

INSTALLATION - SHIFTING CONTROLS

AIR SYSTEM - RTO-11607LL

A. Installation of Slave Valve

NOTE: For air line routing on transmissions equipped with a different combination of control valve and slave valve, see air schematics on pages 35 to 37.



1. Install the actuating pin and spring in bore in transmission.



2. Install the hat type alignment sleeve in the slave valve.

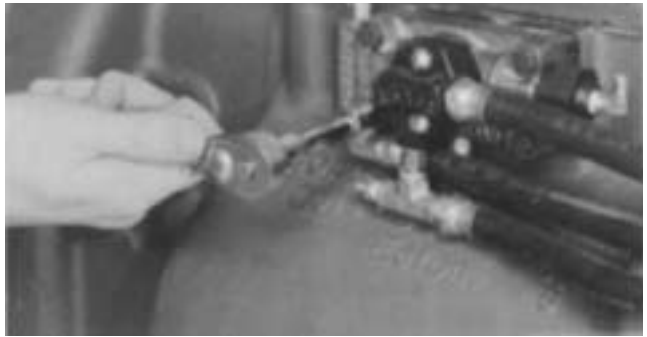

3. Install the slave valve using a new gasket.

B. Installation of Air Lines and Regulator

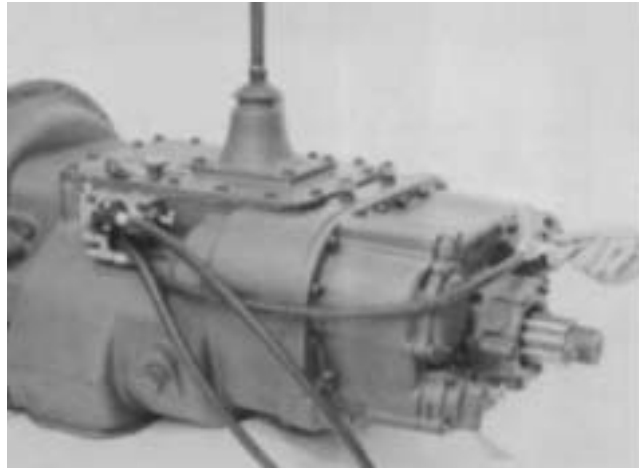

1. Install the air line from the low range port in the slave valve to the body of the range cylinder.

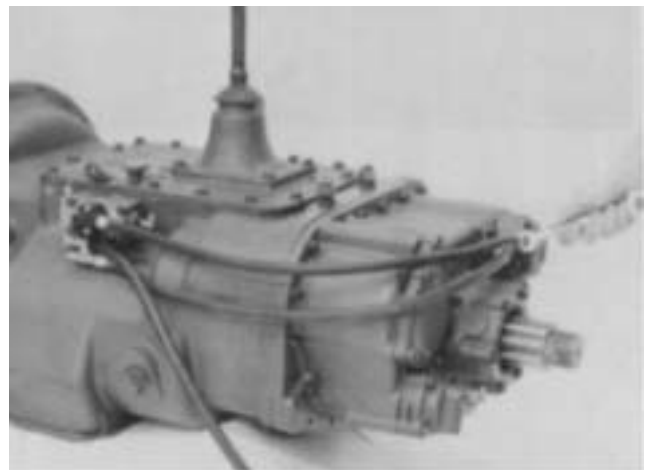

2. Install the line from the high range port of the slave valve to the cover of the range cylinder.

INSTALLATION - SHIFTING CONTROLS

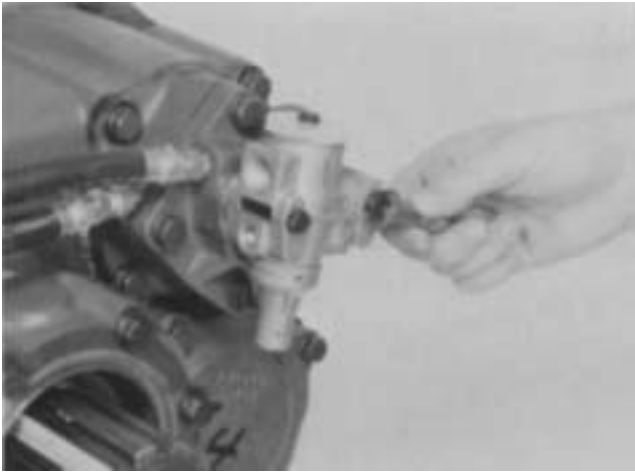

3. Install the air regulator and filter assembly on mounting surface on the range cylinder; tighten capscrews securely.

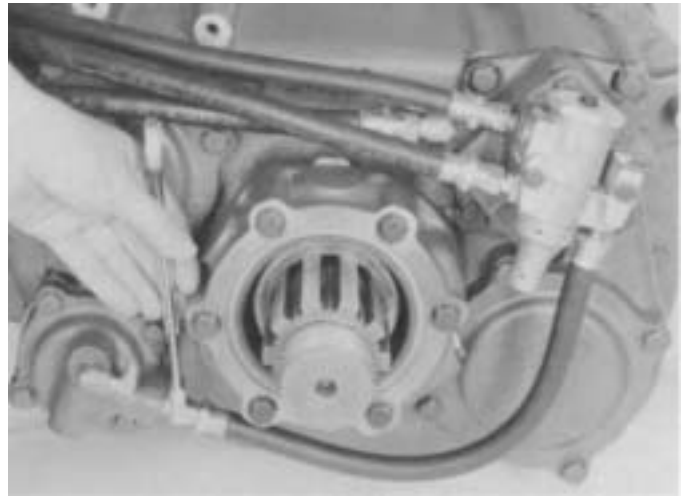

5. Install the air line from the slave valve to the reduction cylinder.

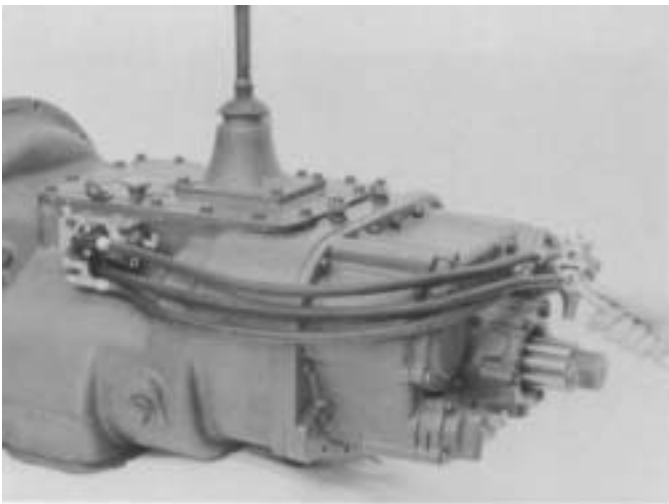

4. Install the air supply line from the slave valve to the air regulator.



6. Install the hose clamp that routes the air lines.

INSTALLATION - SHIFTING CONTROLS

C. To Install the Master Control Valve



1. Install the master control valve on the gear shift lever.
2. If air lines are to be replaced, measure lines and sheathing for correct length.
3. Install sheathing on lines and draw under shroud on lever.



4. Connect the black nylon air line to the "S" port on the master control valve, and the white nylon line to the "P" port.

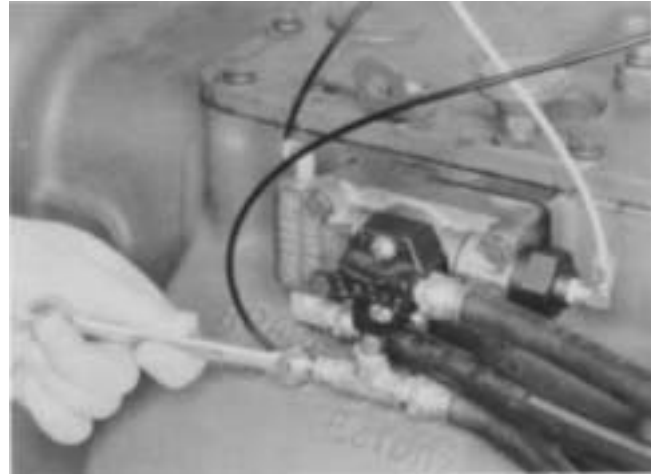

5. Install the nylon air line from the "H" port of the master control valve to the low range port of the slave valve.



6. Install the nylon air line from the "SP" port of the control valve to the reduction cylinder.

Copyright Eaton Corporation, 2012. Eaton hereby grant their customers, vendors, or distributors permission to freely copy, reproduce and/or distribute this document in printed format. It may be copied only in its entirety without any changes or modifications. THIS INFORMATION IS NOT INTENDED FOR SALE OR RESALE, AND THIS NOTICE MUST REMAIN ON ALL COPIES.

Note: Features and specifications listed in this document are subject to change without notice and represent the maximum capabilities of the software and products with all options installed. Although every attempt has been made to ensure the accuracy of information contained within, Eaton makes no representation about the completeness, correctness or accuracy and assumes no responsibility for any errors or omissions. Features and functionality may vary depending on selected options.

For spec'ing or service assistance, call 1-800-826-HELP (4357) or visit www.eaton.com/roadranger. In Mexico, call 001-800-826-4357.

Roadranger: Eaton and trusted partners providing the best products and services in the industry, ensuring more time on the road.

Eaton Corporation

Vehicle Group
P.O. Box 4013
Kalamazoo, MI 49003 USA
800-826-HELP (4357)
www.eaton.com/roadranger

Printed in USA

For parts or service call us
Pro Gear & Transmission, Inc.



1 (877) 776-4600

(407) 872-1901

parts@eprogear.com

906 W. Gore St.

Orlando, FL 32805

