

# Fuller Heavy Duty Transmissions TRSM0507

October 2007

RTX-11509  
RTX-12509  
RTXF-11509  
RTXF-12509



*Powering Business Worldwide*

BACKED BY

**Roadranger**

SUPPORT

For parts or service call us  
Pro Gear & Transmission, Inc.



**1 (877) 776-4600**

**(407) 872-1901**

**parts@eprogear.com**

**906 W. Gore St.**

**Orlando, FL 32805**



## **Contents**

Specifications  
Lubrication  
Disassembly Precautions  
Inspection  
Reassembly Precautions  
Shifting Controls  
    Air Systems  
    Air Valves  
    Filter/Regulator  
    Gear Shift Lever Housing  
    Shift Bar Housing  
Auxiliary Sections  
    Removal & Installation  
    RT-12509 Disassembly  
    RT-12509 Reassembly  
    RTO-1258LL Disassembly  
    RTO-1258LL Reassembly  
    RT-12513 Disassembly  
    RT-12513 Reassembly  
Front Section-All Models  
    Disassembly  
    Reassembly  
Torque Recommendations  
Changing Input Shaft  
Tools

## Letter and Model Designations

### **EXAMPLE: RTOF-12513**

"R" - Roadranger Transmission

"T" - Twin Countershaft

"O" - Overdrive

"F" - Denotes special shift bar housing which has the gear shift lever mounted forward of the normal position

"125" - Number x 10 = Torque Capacity: 125 x 10 = 1250 lbs./ft. Torque Capacity

"13" - Number of Forward Speeds

- RTO-1258LL** - Roadranger, Twin Countershaft, Overdrive, 1250 lbs./ft. Torque Capacity, 8 Progressive Forward Speeds plus a Low Gear and a Low-Low Gear
- RT-12509** - Roadranger, Twin Countershaft, 1250 lbs./ft. Torque Capacity, 9 Forward Speeds
- RTO-12509** - Same as above but with an Overdrive Ratio
- RT-12513** - Roadranger, Twin Countershaft, 1250 lbs./ft. Torque Capacity, 13 Forward Speeds
- RTO-12513** - Same as above but with an Overdrive Ratio

### **Order No.**

P-539 - Illustrated Parts List - RTO-1258LL

P-518 - Illustrated Parts List - RT-12509 Series

P-509 - Illustrated Parts List - RT-12513 Series

102 - Trouble Shooting Guide

121 - Lubrication Recommendations

52059 - Driver Instructions - RTO-1258LL

52067 - Driver Instructions - RT/RTO-12509

52068 - Driver Instructions - RTO-12513 3-position Splitter Knob

52069 - Driver Instructions - RT-12513 2-position Splitter Knob

52070 - Driver Instructions - RTO-12513 2-position Splitter Knob

# Specifications

## Specifications RTO-1258LL

Power Take-Off - Right Side, SAE standard 6-bolt regular duty type, short length. Bottom, SAE standard 13-bolt heavy-duty type.

PTO Drive Gear Speeds - Right Side, 45-tooth 6/8 pitch gear. Bottom, 47-tooth 6/8 pitch gear. Both turning at .944 engine speed.

Clutch Housing Size - SAE No. 1 cast iron.

Installation Dimensions - From face of clutch housing to front (bottoming) face of companion flange hub 33.6" (854mm).

Weight - RTO-1258LL, 770 lbs. (350 Kg.)

Oil Capacity - Approximately 28 pints (13.2 litres).

## Specifications RT-12509 Series

Power Take-Off - Two SAE standard openings, short length.

Right Side: Regular duty, 6-bolt type. PTO gear is 45-tooth, 6/8 pitch turning at .700 engine speed on RT-12509 models, .944 on RTO 12509 models.

Bottom: Heavy-duty, 8-bolt type. PTO gear is 47-tooth, 6/8 pitch turning at .700 engine speed on RT-12509 models, .944 on RTO-12509 models.

Clutch Housing Size - SAE standard No. 1 cast iron for push or pull type clutches.

Weight - 680 lbs. (308 Kg. )

Installation Dimensions - From face of clutch housing to front (bottoming) face of companion flange hub 29.5" (749mm).

Oil Capacity - 25 pints (12 litres), depending upon inclination of engine and transmission.

## Specifications RT-12513 Series

Power Take-Off - Two SAE standard openings for 6/8 pitch gears.

Right Side: Regular duty type, 6-bolt, short length with 4.5-tooth PTO gear turning at .700 engine speed.

Bottom: Heavy duty type, 8-bolt, with 47-tooth PTO gear turning at .700 engine speed.

Clutch Housing Size - For flush or pull type two-plate clutches. SAE NO. 1 cast iron.

Weight - 725 lbs. (329 Kg).

Installation Dimensions - From face of clutch housing to front (bottoming) face of companion flange hub 32.4" (823mm).

Oil Capacity - Approximately 27 pints (13 litres), depending upon inclination of engine and transmission.

# Lubrication

## Proper Oil Level

Make sure oil is level with filler opening. Because you can reach oil with your finger does not mean oil is at proper level.

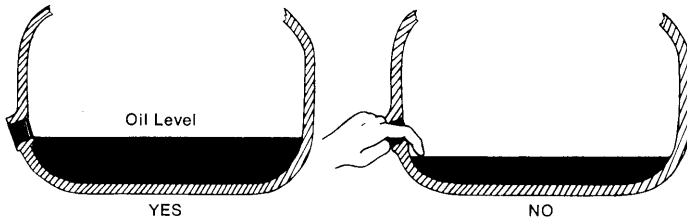

## Draining Oil

Drain transmission while oil is warm. To drain oil remove the drain plug at bottom of case. Clean the drain plug before re-installing.

## Refilling

Clean area around filler plug and remove plug from side of case. Fill transmission to the level of the filler opening.

The exact amount of oil will depend on the transmission inclination and model. *In every instance, fill to the level of the filler opening.*

Do not over fill - this will cause oil to be forced out of the case through mainshaft openings.

## Adding Oil

It is recommended that types and brands of oil not be intermixed because of possible incompatibility.

## Operating Temperature

It is important that the transmission operating temperature does not exceed 250°F. ( 120°C.) for an extended period of time. Operating temperatures above 250°F: will cause breakdown of the oil and shorten transmission life.

The following conditions in any combination can cause operating temperatures of over 250°F: (1) Operating consistently at roadspeeds under 20 MPH, (2) high engine RPM, (3) high ambient temperature, (4) restricted air flow around transmission, (5) exhaust system too close to transmission, (6) high horsepower, over-drive operation. High operating temperatures may require more frequent oil changes.

External cooler kits are available to keep the transmission operating temperature under 250° F. when the conditions described above are encountered.

If the transmission operating angle is more than 12 degrees, improper lubrication can occur. The operating angle is the transmission mounting angle in the chassis plus the percent of upgrade (expressed in degrees ).

Anytime the transmission operating angle of 12 degrees is exceeded for an extended period of time the transmission should be equipped with an oil pump or cooler kit to insure proper lubrication.

Note the effect low oil levels can have on safe operating angles. Allowing the oil level to fall 1/2" below the filler plug hole reduces the degree of grade by approximately 3 degrees (5.5 percent).

RECOMMENDED LUBRICANTS		
ON-HIGHWAY VEHICLES		
Type	Grade	Temperature
Heavy Duty Engine Oil MIL-L-2104C, or MIL-L-46152, or AP1-SE, or AP1-CC	SAE 50 or SAE 40 SAE 30	Above + 10°F. (-12.5°C.) Below + 10°F.
Mineral Gear Oil R and O Type	SAE 90 SAE 80W	Above + 10°F. Below + 10°F.
OFF-HIGHWAY		
Heavy Duty Engine Oil MIL-L-2104C, or MIL-L-46152, or AP1-SE, or AP1-CC	SAE 50 or SAE 40 SAE 30	Above + 10°F. Below + 10°F.
<b>Special Recommendation - For extreme cold weather where temperature is consistently below 0°F.</b>		
Heavy Duty Engine Oil MIL-L-2104C, or MIL-L-46152, or AP1-SE, or AP1-CC	SAE 20W	Below 0°F. (-18°C.)

Lubrication Change and Inspection	
HIGHWAY USE	
Every 5,000 miles (8045 Km)	Inspect oil level. Check for leaks.
Every 50,000 miles (80450 Km)	Change transmission oil.
OFF-HIGHWAY	
First 30 hours	Change transmission oil on new units.
Every 40 hours	Inspect oil level. Check for leaks.
Every 500 hours	Change transmission oil where severe dirt conditions exist.
Every 1,000 hours	Change transmission oil (Normal off-highway use).
Change oil filter element, if so equipped, at each oil change.	

# Disassembly Precautions

It is assumed in the detailed disassembly instructions that the lubricant has been drained from the transmission, the necessary linkage and air lines removed and the transmission has been removed from the chassis. Removal of the gear shift lever housing assembly is included in the detailed instructions; however, this assembly must also be removed from transmission before removing unit from vehicle.

**Follow each procedure closely in each section, making use of both the text and pictures.**

**1. BEARINGS** - Carefully wash and relubricate all bearings as removed and protectively wrap until ready for use. Remove bearings with pullers designed for this purpose.

**2. ASSEMBLIES** - When disassembling the various assemblies, such as the mainshaft, countershafts and shifting bar housing, lay all parts on a clean bench in the same sequence as removed. This procedure will simplify m-assembly and reduce the possibility of losing parts.

**3. SNAP RINGS** - Remove snap rings with pliers designed for this purpose. Rings removed in this manner can be reused.

**4. INPUT SHAFT** - The clutch or input shaft can be removed without removing the countershaft, mainshaft or drive gear.

**5. CLEANLINESS** - Provide a clean place to work. It is important that no dirt or foreign material enters the unit during repairs. The outside of the unit should be carefully cleaned before starting the disassembly. Dirt is abrasive and can damage bearings.

**6. WHEN DRIVING** - Apply force to shafts, housings, etc., with restraint. Movement of some parts is restricted. Do not apply force after the part being driven stops solidly. Use soft hammers and bars for all disassembly work.

---

## Inspection

Before reassembling the transmission, the individual parts should be carefully checked to eliminate those damaged from previous service. This inspection procedure should be carefully followed to insure the maximum of wear life from the rebuilt unit.

The cost of a new part is generally a small fraction of the total cost of downtime and labor, should the use of a questionable part make additional repairs necessary before the next regularly scheduled overhaul.

Recommended inspection procedures are set forth in the following check list:

### A. Bearings

1. Wash all bearings in clean solvent. Check balls, rolls and races for pits and spalled areas. Replace bearings which are pitted or spalled.
2. Lubricate bearings which are not spalled or pitted and check for axial and radial clearances. Replace bearings with excessive clearances.
3. Check fits of bearings in case bores. If outer races turn freely in the bores, the case should be replaced.

### B. Gears

1. Check operating gear teeth for pitting on the tooth faces. Gears with pitted teeth should be replaced.
2. Check all engaging gear teeth. Gears with teeth worn, tapered or reduced in length from clashing in shifting should be replaced.
3. Check axial clearances of gears. Where excessive clearance is found, check gear snap ring, washer, spacer

and gear hub for excessive wear. Maintain .005 to .012 axial clearance of mainshaft forward speed gears, .005 minimum on reverse gear.

### C. Splines

1. Check splines on all shafts for wear. If sliding clutch gears, companion flange or clutch hub have worn into the sides of the splines, the shafts in this condition should be replaced.

### D. Thrust Washers

1. Check surfaces of all thrust washers. Washers scored or reduced in thickness should be replaced.

### E. Reverse Gear and Shaft

1. Check bearing sleeve for wear from action of roller bearings.

### F. Gray Iron Parts

1. Check all gray iron parts for cracks and breaks. Replace or repair parts found to be damaged. Heavy castings may be welded or brazed providing the cracks do not extend into bearing bores or bolting surfaces.

### G. Clutch Release Parts

1. Check clutch release parts. Replace yokes worn at cam surfaces and bearing carrier worn at contact pads.
2. Check pedal shafts. Replace those worn at bearing surfaces.

## H. Shifting Bar Housing Assembly

1. Check yokes and blocks for wear at pads and lever slot. Replace worn parts.
2. Check yokes for alignment. Straighten those which are sprung.
3. Check yokes for excessive wear; replace worn yokes.
4. Check lockscrews in yokes and blocks. Tighten and re-wire those found loose.
5. If housing has been dismantled, check neutral notches of shifting bars for wear from interlock balls. Bars indented at points adjacent to the neutral notch should be replaced.

## 1. Gear Shift Lever Housing Assembly

1. Check spring tension on shift lever. Replace tension spring and washer if lever moves too freely.
2. If housing is dismantled, check pivot or spade pin and corresponding slot in lever for wear. Replace both parts if worn.

## J. Bearing Covers

1. Check covers for wear from thrust of adjacent bearing. Replace covers worn and grooved from thrust of bearing outer race.
2. Check bores of covers for wear. Replace those worn oversize.

## K. Oil Return Threads and Seals

1. Check oil return threads in front bearing cover. If sealing action of threads has been destroyed by contact with input shaft, replace the cover.
2. Check oil seal in mainshaft rear bearing cover. If sealing action of lip has been destroyed, replace seal.

## L. Synchronizers

1. Check high and low range synchronizers for burrs, uneven and excessive wear at contact surface, and metal particles.
2. Check blocker pins for excessive wear or looseness.
3. Check synchronizer contact surfaces on the high and low range gears for excessive wear.

## M. Sliding Clutches

1. Check all yokes and yoke slots in sliding clutches for extreme wear or discoloration from heat.
2. Check engaging teeth of sliding clutches for partial engagement pattern.

## N. Front Bearing Cover

1. Check inside hub of front bearing cover for wear caused by backing off of drive gear bearing nut.

## O. O-Rings

1. Check all O-rings for cracks or distortion. Replace if worn.

---

## Reassembly Precautions

Make sure that interiors of case and housings are clean. It is important that dirt be kept out of transmission during reassembly. Dirt is abrasive and can damage polished surfaces of bearings and washers. Use certain precautions, as listed below, during reassembly.

- 1. GASKETS** - Use new gaskets throughout the transmission as it is being rebuilt. Make sure all gaskets are installed, as omission of gasket can result in oil leakage or misalignment of bearing covers, See "Location of Gaskets" heading.
- 2. CAPSCREWS** - To prevent oil leakage, use thread sealant on all capscrews. See torque rating chart for recommended torque.
- 3. O-RINGS** - Lubricate all O-rings with silicone lubricant.
- 4. ASSEMBLY** - Refer to the disassembly illustrations as a guide to reassembly.
- 5. INITIAL LUBRICATION** - Coat all thrust washers and splints of shafts with Lubriplate during installation

to provide initial lubrication, preventing scoring and galling.

**6. AXIAL CLEARANCES** - Maintain original axial clearances of mainshaft forward speed gears of .005" to .012". Mainshaft reverse gear clearance is a minimum of .005".

**7. BEARINGS** - Use of flanged-end bearing drivers is recommended for the installation of bearings. These drivers apply equal force to both races of bearing, preventing damage to balls and races and maintaining correct bearing alignment with shaft and bore. If tubular or sleeve type driver is used, apply force only to inner race.

**8. UNIVERSAL JOINT COMPANION FLANGE** - Pull the companion flange tightly into place with the mainshaft nut, using 450-500 foot-pounds of torque. Make sure the speedometer gear has been installed on yoke. If a speedometer gear is not used, a replacement spacer of the same width must be used. Failure to pull the yoke or flange tightly into place will permit the shaft to move axially with resultant damage to rear bearing.



# Shifting Controls

## I. Deep Reduction Air Lines - RTO-1258LL

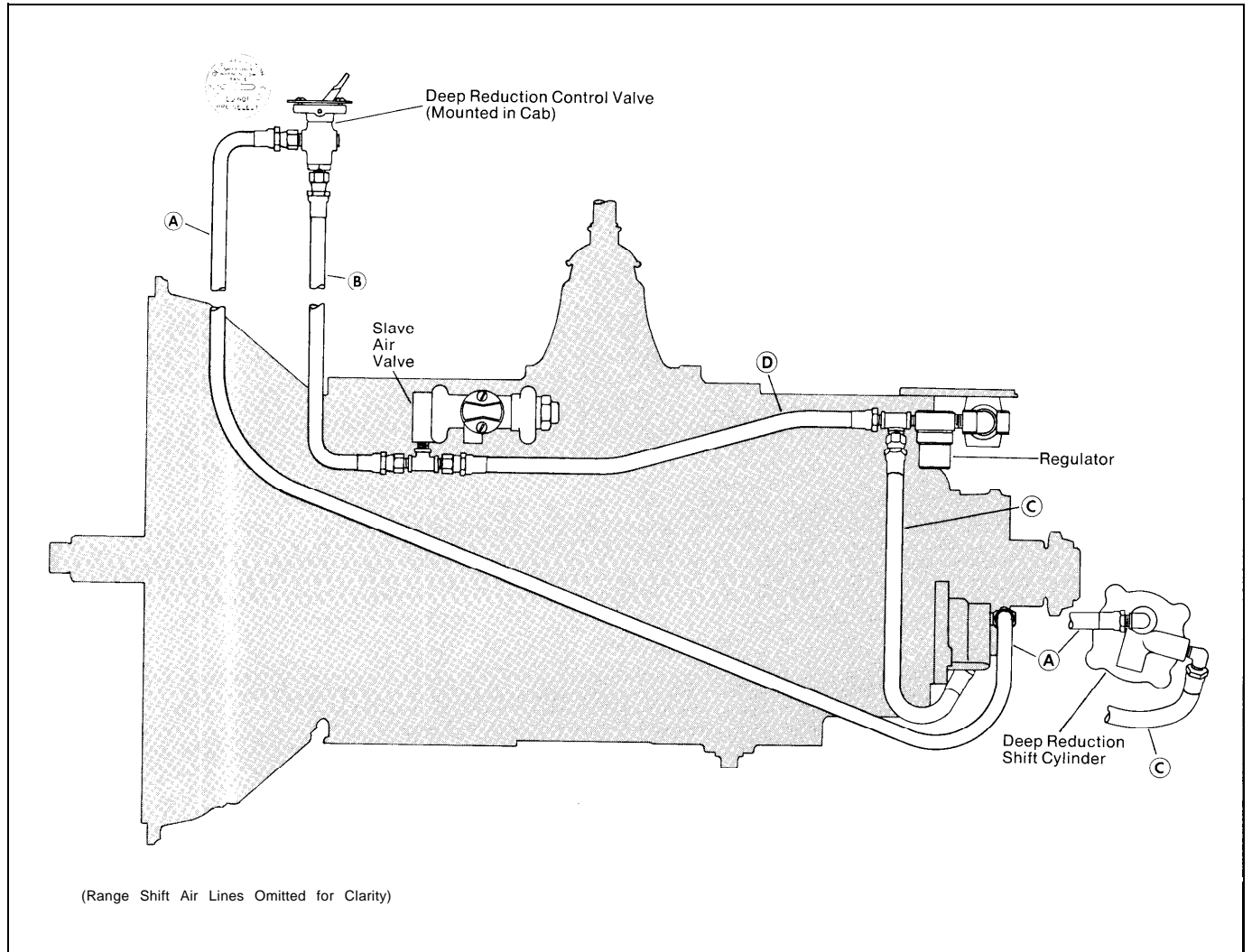

### A. REMOVAL

1. Disconnect the signal air line (A) and the supply air line (B) from between the transmission and the deep reduction control valve mounted in the cab.
2. Disconnect the 1/4" ID deep reduction shift cylinder supply air line (C) from between the shift cylinder and the tee fitting forward of the regulator.
3. Disconnect the 1/4" ID slave air valve supply line (D) from between the slave air valve and the tee fitting forward of the regulator.

### B. INSTALLATION

1. Install the 18" 1/4" ID slave air valve supply line (D) between the slave air valve and the tee fitting forward of the regulator.
2. Install the 17" supply air line (C) between the fitting forward of the regulator and the deep reduction shift cylinder.
3. Install the control valve supply air line (B) between the slave air valve and the "IN" port of the control valve.
4. Install the signal air line (A) between the deep reduction shift cylinder and the "OUT" port of the control valve.

## II. Splitter Gear Air Lines - RT-12513 Series (Two Position Valve)

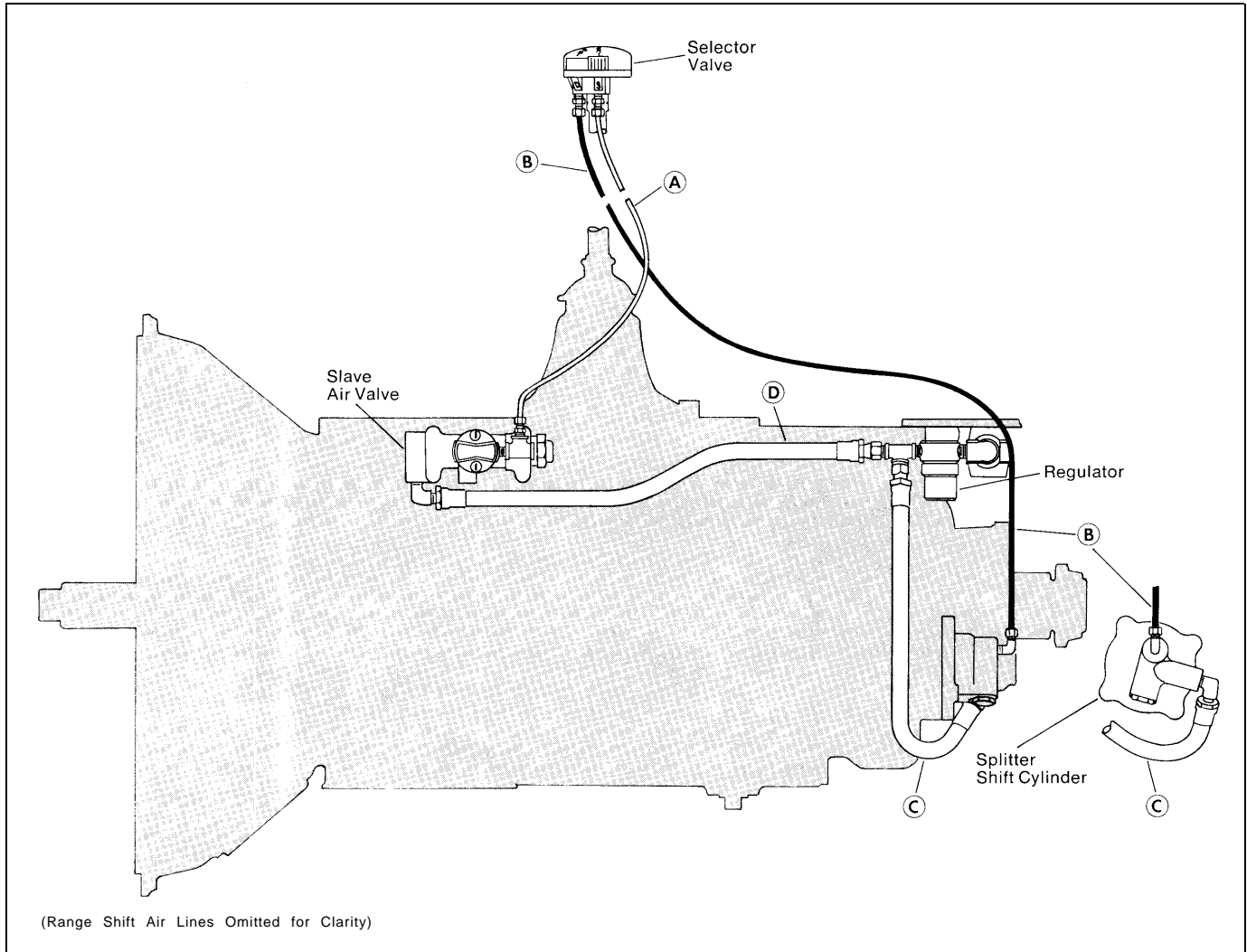

### A. REMOVAL

1. Disconnect the white 1/8" OD supply air line (A) from between the tee fitting on the slave air valve and the "S" port on the selector valve.
2. Disconnect the black 1/8" OD signal air line (B) from between the splitter shift cylinder and the "D" port of the selector valve.
3. Disconnect the 1/4" ID supply air line (C) from between the tee fitting forward of the regulator and the splitter shift cylinder.
4. Disconnect the 18" 1/4" ID slave air valve supply line (D) from between the air valve and the tee fitting forward of the regulator.

### B. INSTALLATION

1. Connect the 18" 1/4" ID supply air line (D) between the slave air valve and the tee fitting forward of the regulator.
2. Connect the 1/4" ID supply air line (C) between the splitter shift cylinder and the tee fitting forward of the regulator.
3. Connect the black 1/8" OD signal air line (B) between the splitter shift cylinder and the "D" port of the selector valve.
4. Connect the white 1/8" ID supply air line (A) between the tee fitting on the slave air valve and the "S" port on the selector valve.

# Shifting Controls - continued

## III. Splitter Gear Air Lines - RT-12513 Series (Three position valve)

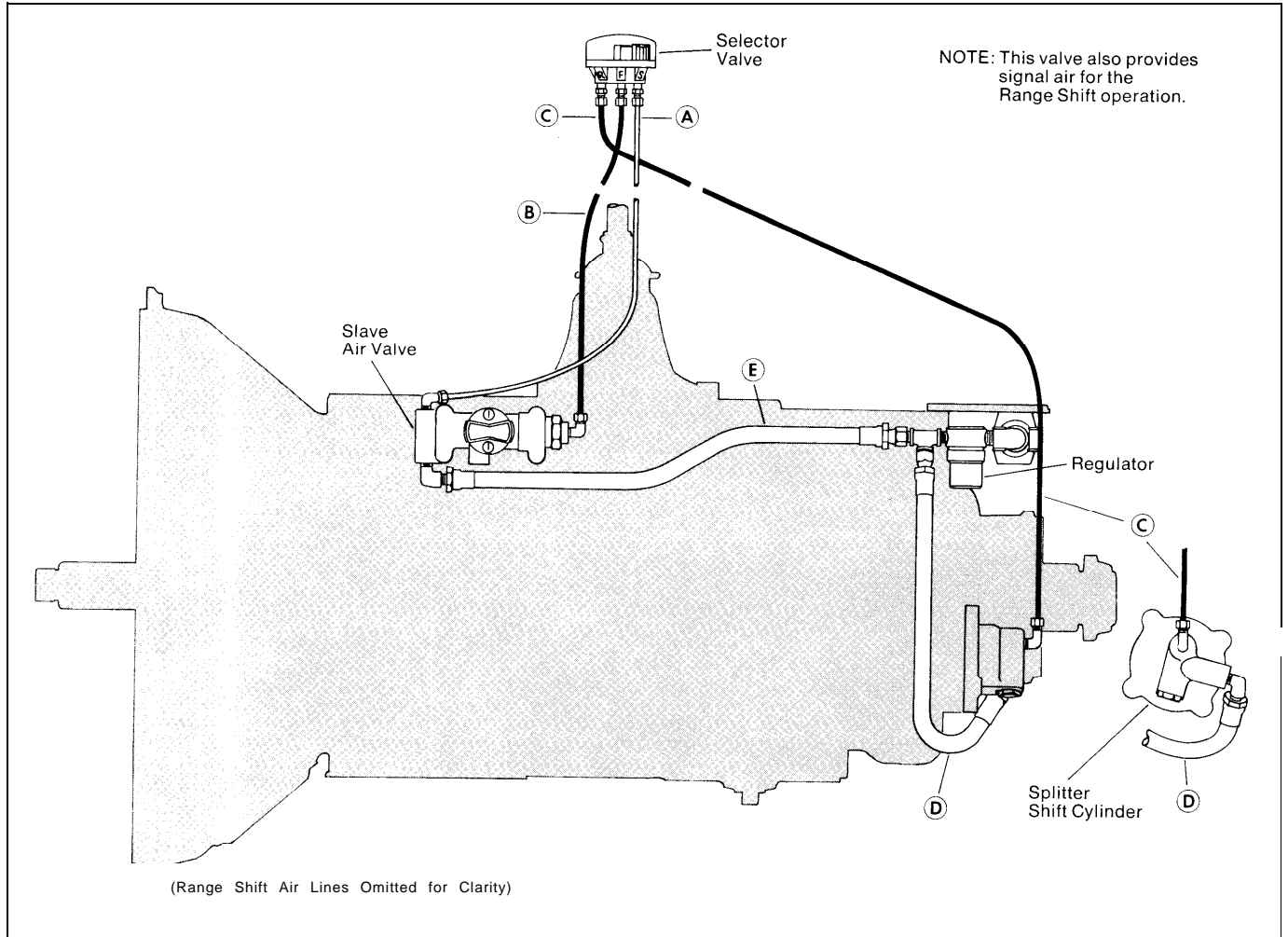

### A. REMOVAL

1. Disconnect the white 1/8" OD supply air line (A) from between the slave air valve and the selector valve.
2. Disconnect the black 1/8" OD range shift signal air line (B) from between the slave air valve and the selector valve.
3. Disconnect the black 1/8" OD splitter shift signal air line (C) from between the selector valve and the splitter shift cylinder.
4. Disconnect the "A" OD supply air line (D) from between the splitter shift cylinder and the tee fitting forward of the regulator.
5. Disconnect the 1/4" ID slave air valve supply line (E) from between the slave air valve and the tee fitting forward of the regulator.

### B. INSTALLATION

1. Install the 18" 1/4" ID supply air line (E) between the slave air valve and the tee fitting forward of the regulator.
2. Install the 17" 1/4" ID supply air line (D) between the splitter shift cylinder and the tee fitting forward of the regulator.
3. Install the 1/8" OD signal air line (C) between the splitter shift cylinder and the "R" port of the selector valve.
4. Install the 1/8" OD signal air line (B) between the slave air valve and the "F" port of the selector valve.
5. Install the 1/8" OD supply air line (A) between the slave air valve and the "S" port of the selector valve.

## IV. Range Shift Air Lines - All Models

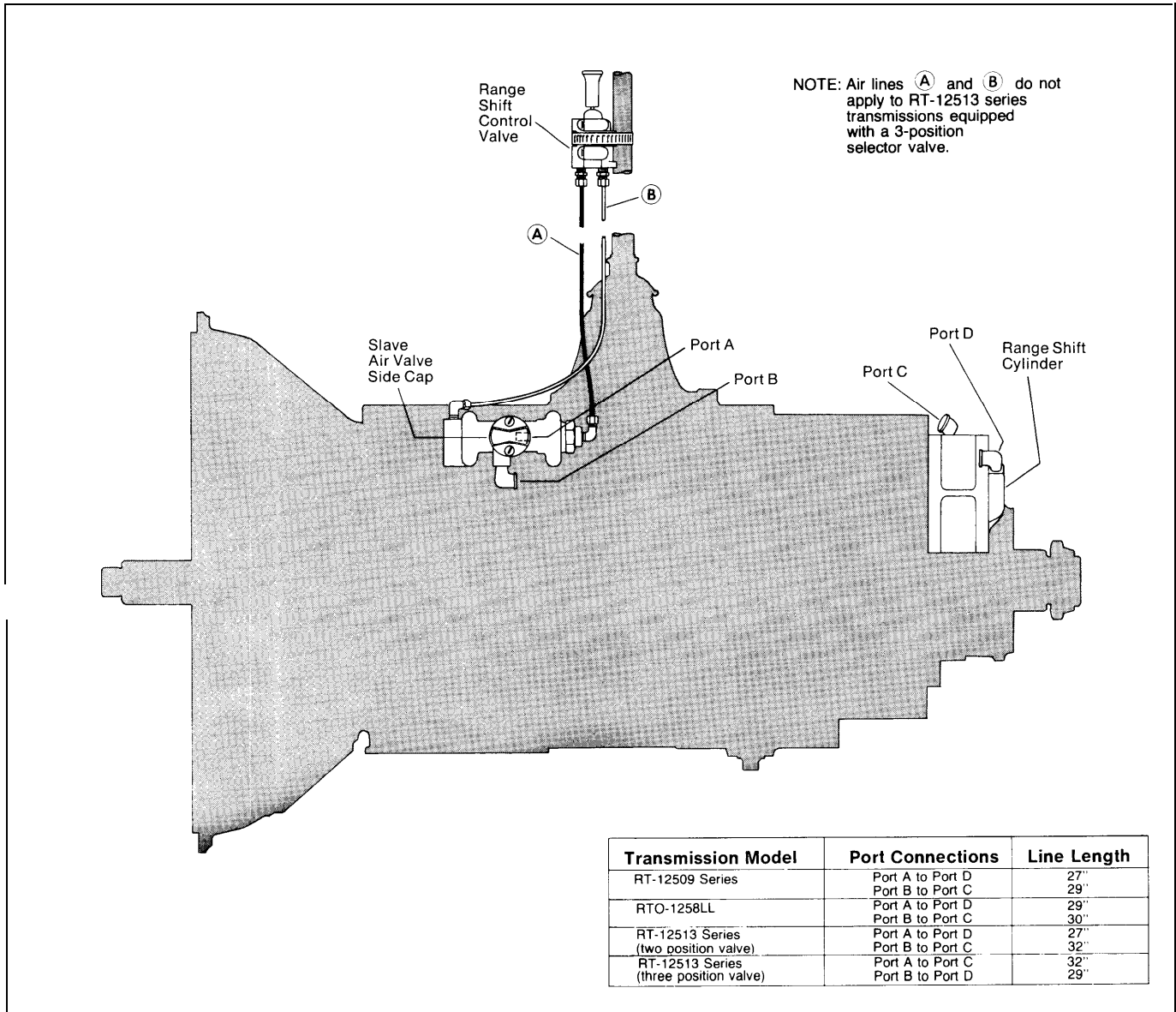

### A. REMOVAL

1. Disconnect the black and white 1/8" OD air lines (A and B) from between the slave air valve and the range shift control valve.
2. Disconnect the two 1/4" ID air lines from between the slave air valve side cap and the range shift cylinder.

### B. INSTALLATION

1. Disconnect the black and white 1/8" OD supply air line between the forward port on the slave air valve and the rear port on the range shift control valve.
2. Install the black 1/8" OD signal air line between the rear port on the slave air valve and the forward port on the range control valve.
3. Use the chart to install the "A" ID air lines between the slave air valve side cap and the range shift cylinder.

# Shifting Controls - continued

## V. Two and Three Position Selector Valves

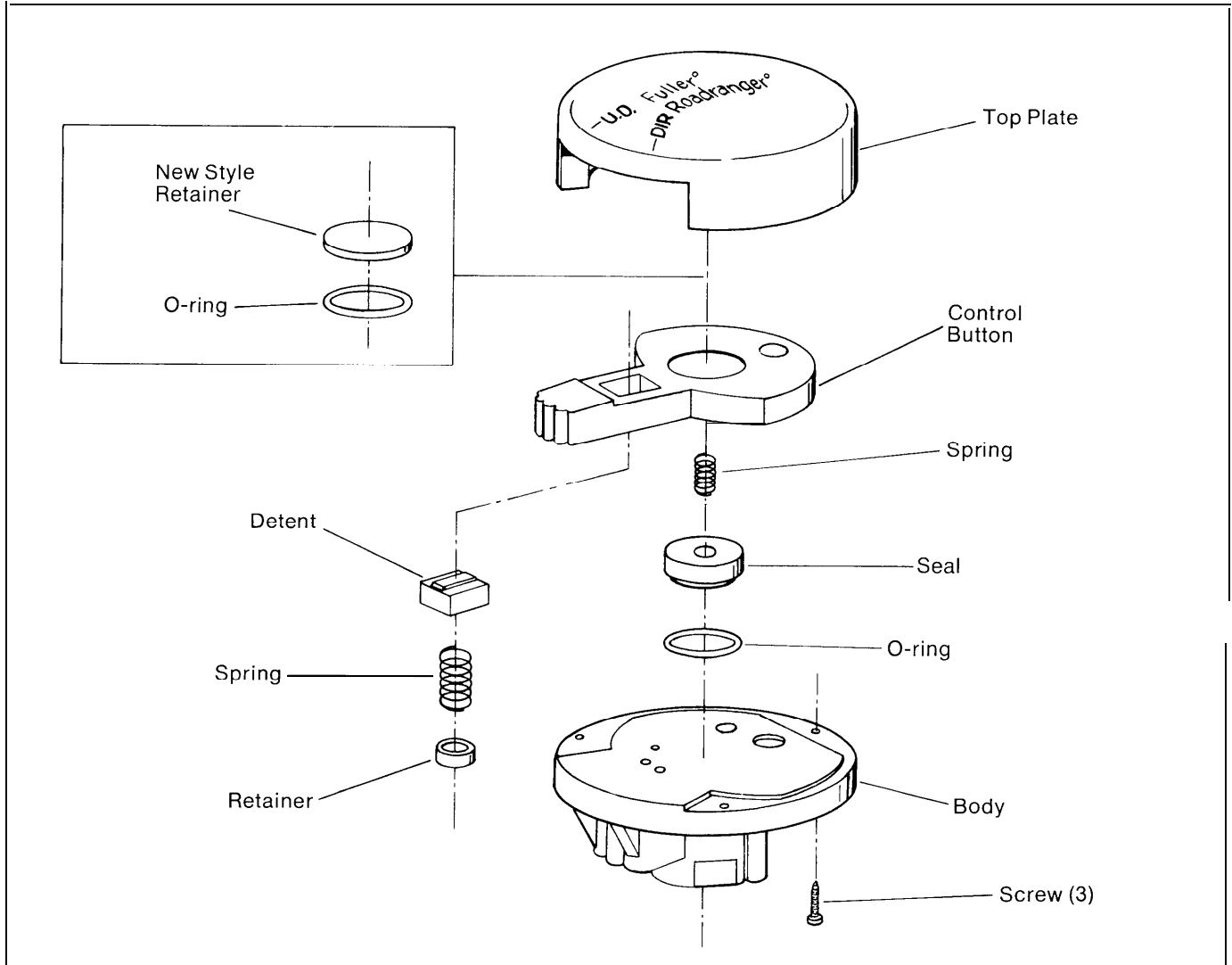

### A. REMOVAL AND DISASSEMBLY

1. Disconnect all air lines to the valve. Loosen the jam nut securing the valve to the gear shift lever and turn the valve from the lever.
2. Remove the three screws on the bottom of the valve and lift the top cover from the body.
3. Remove the actuator from the top cover post and remove the springs, seals, O-rings and detent parts from the actuator.

### B. REASSEMBLY AND INSTALLATION

1. Refer to the drawing for proper assembly of the springs, seals, O-ring and detent parts. Use a VERY SMALL amount of silicone lubricant on the O-rings to avoid clogging the valve ports.
2. Install the air lines with their sheathing and O-rings on the gear shift lever.
3. Install the jam nut on the lever and install the selector valve. Use the jam nut to lock the valve in position with the actuator button facing the driver's seat.
4. Install the 1/8" OD air lines.

## VI. Range Control Valve

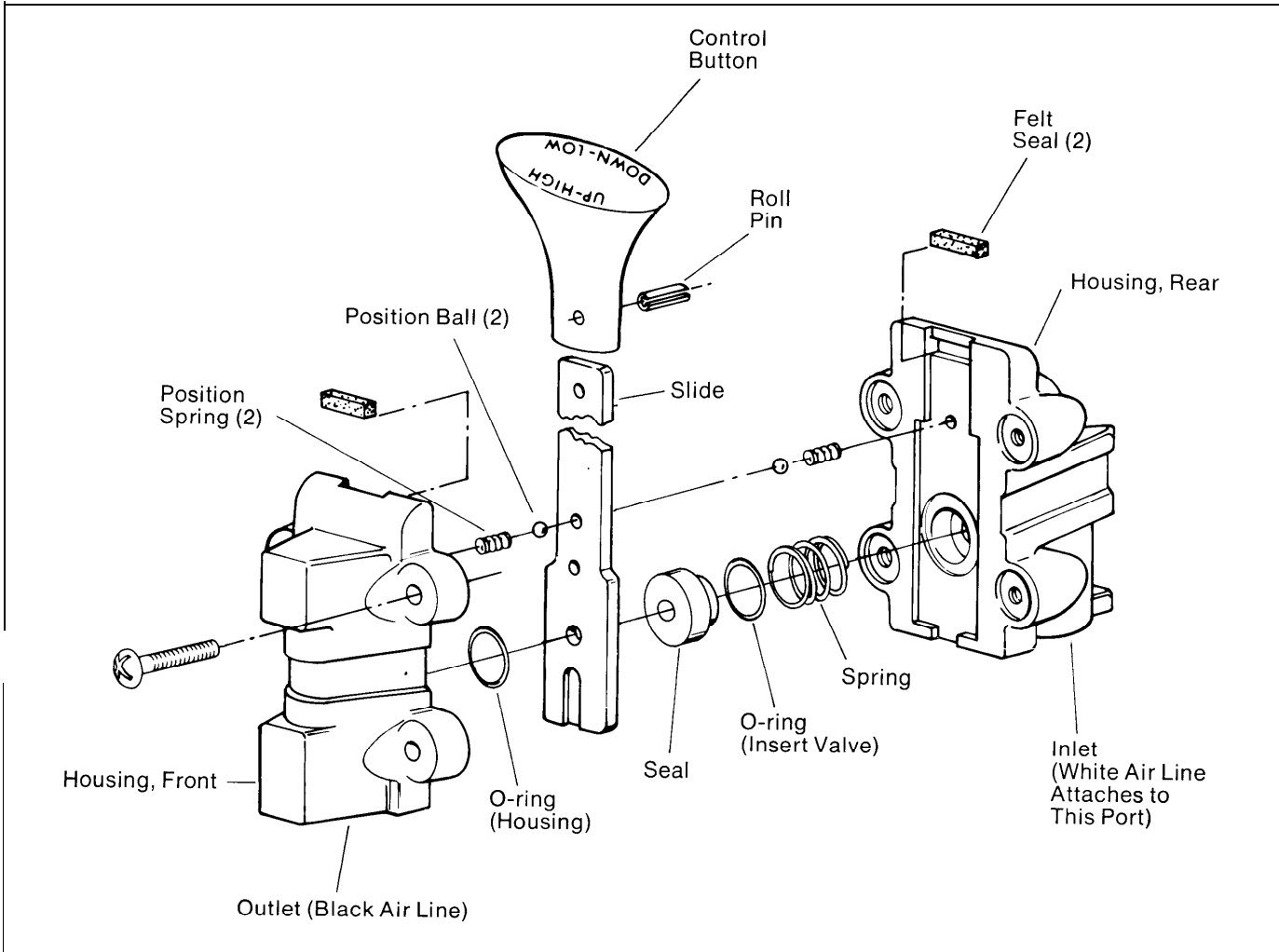

### A. REMOVAL AND DISASSEMBLY

1. Disconnect the air lines and loosen the clamp securing the valve to the gear shift lever. Remove valve.
2. Remove the four screws to separate the front and rear housings and remove the slide and two sets of position springs and balls.
3. Remove the valve plate, insert O-rings and wave washer from the valve bodies.
4. If necessary, remove the two felt seals. Punch out the roll pin to remove the button from the slide.

### B. REASSEMBLY AND INSTALLATION

1. Refer to the drawing for proper reassembly. Use a VERY SMALL amount of silicone lubricant on the O-rings to avoid clogging the ports. A small amount of grease on the position springs and balls will help to hold them in place during reassembly.
2. Install the air lines with their sheathing and O-rings on the gear shift lever.
3. Secure the valve on the gear shift lever with the clamp. The control button should face to the front and be approximately 6" below the centerline of the shift knob or selector valve.
4. Attach the air lines.

# Shifting Controls - continued

## VII. Slave Air Valve - All Models

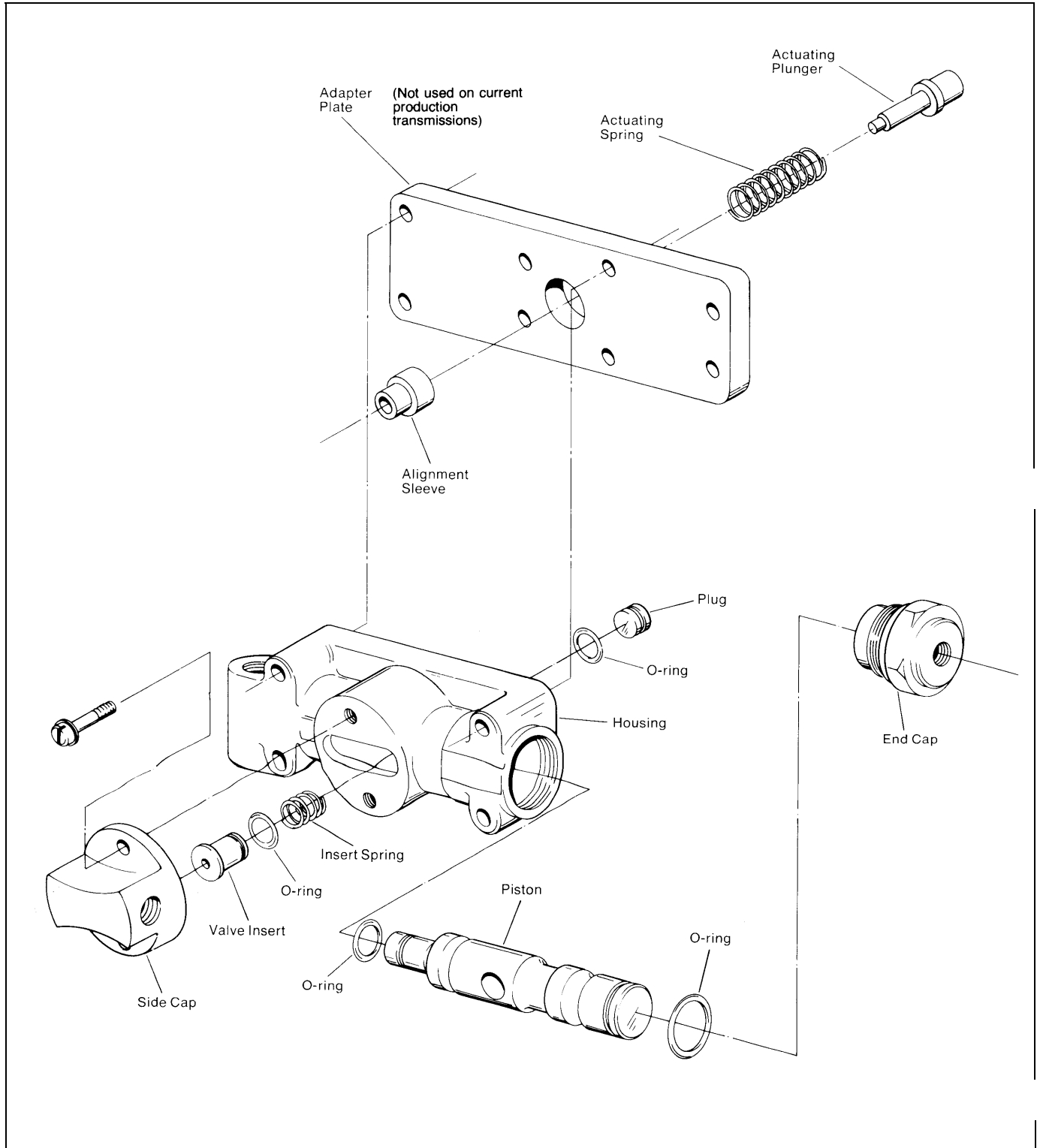

## A. REMOVAL AND DISASSEMBLY

1. Turn out the four capscrews, jar lightly to break the gasket seal and remove the air valve from the adapter plate.

2. Remove the alignment sleeve which will be either in the adapter plate bore or on the back of the air valve.

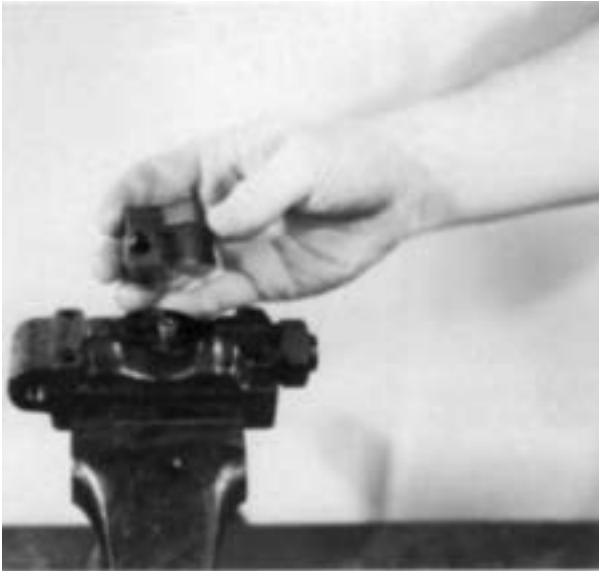

3. Chuck the valve in a vise by the top and bottom and remove all brass fittings if necessary. Turn out the two screws and remove the side cap.



4. Remove the valve insert from the piston and remove the O-ring from the valve insert.

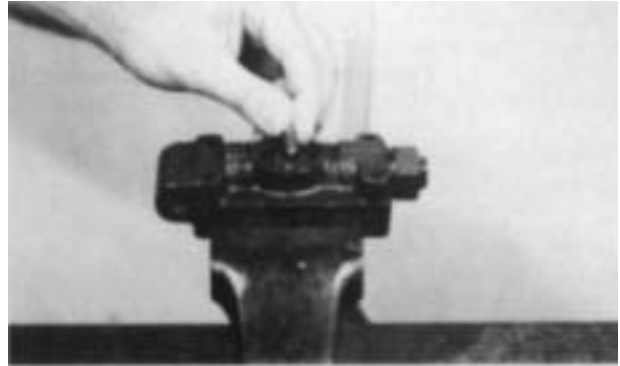

5. Remove the insert spring from the piston.



6. Turn the end cap from the valve body and remove the piston from the bore.

7. Remove the two O-rings from the piston.

8. Remove the nylon plug from the piston and remove the O-ring from the plug.

9. Remove the actuating spring and plunger from the adapter plate or case bore.

10. If so equipped, turn out the two Allen head screws and two capscrews and remove the adapter plate from the transmission side.



# Shifting Controls - continued

## VII. Slave Air Valve - All Models

### B. REASSEMBLY AND INSTALLATION

1. If so equipped, install the adapter plate and gasket on the transmission with the two Allen head screws and two capscrews. Use the alignment sleeve to make sure that the bore in the adapter plate lines up properly with the case bore.

2. Install the actuating plunger in the plate bore with the small end facing out.

3. Install the actuating spring over the plunger.



4. Install the O-rings on the piston and apply a thin coat of silicone lubricant. Install the piston in the valve body with the large end facing out and the piston bore lined up with the slot in the side cap mounting surface.

5. Install the O-ring on the plug and apply a thin coat of silicone lubricant. Insert the plug into the piston bore with the flat surface facing out.



6. Install the insert spring in the bore. Install the O-ring on the valve insert and apply a thin coat of silicone lubricant. Install the valve insert in the bore with the large end facing out.

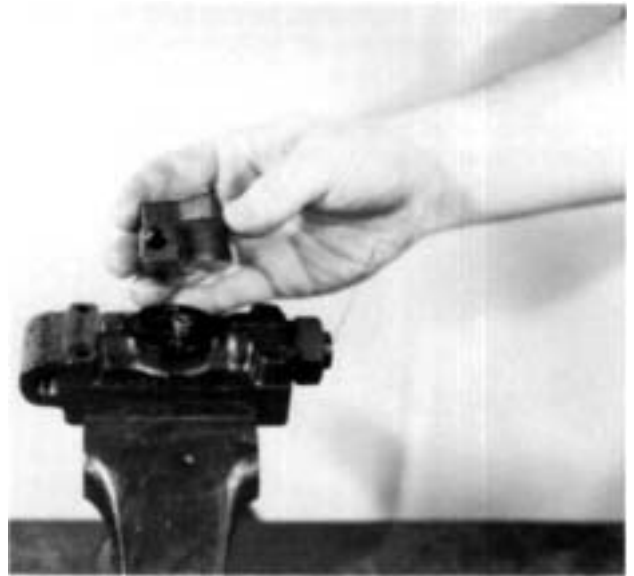

7. Apply a thin coat of Lubriplate to the machined face of the side cap and install the side cap on the valve body.

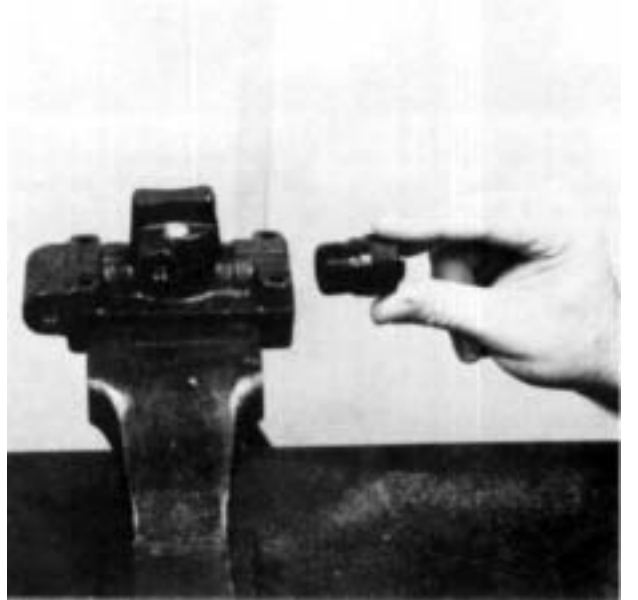

8. Install the end cap on the valve body. **DO NOT** use more than 40 lbs.-ft. of torque or the end cap will bind the piston.

9. Install the alignment sleeve in the bore in the back of the valve and install the valve and gasket on the adapter plate. If previously removed, install the brass fittings on the valve.

## VII. Filter/Regulator Assembly - All Models

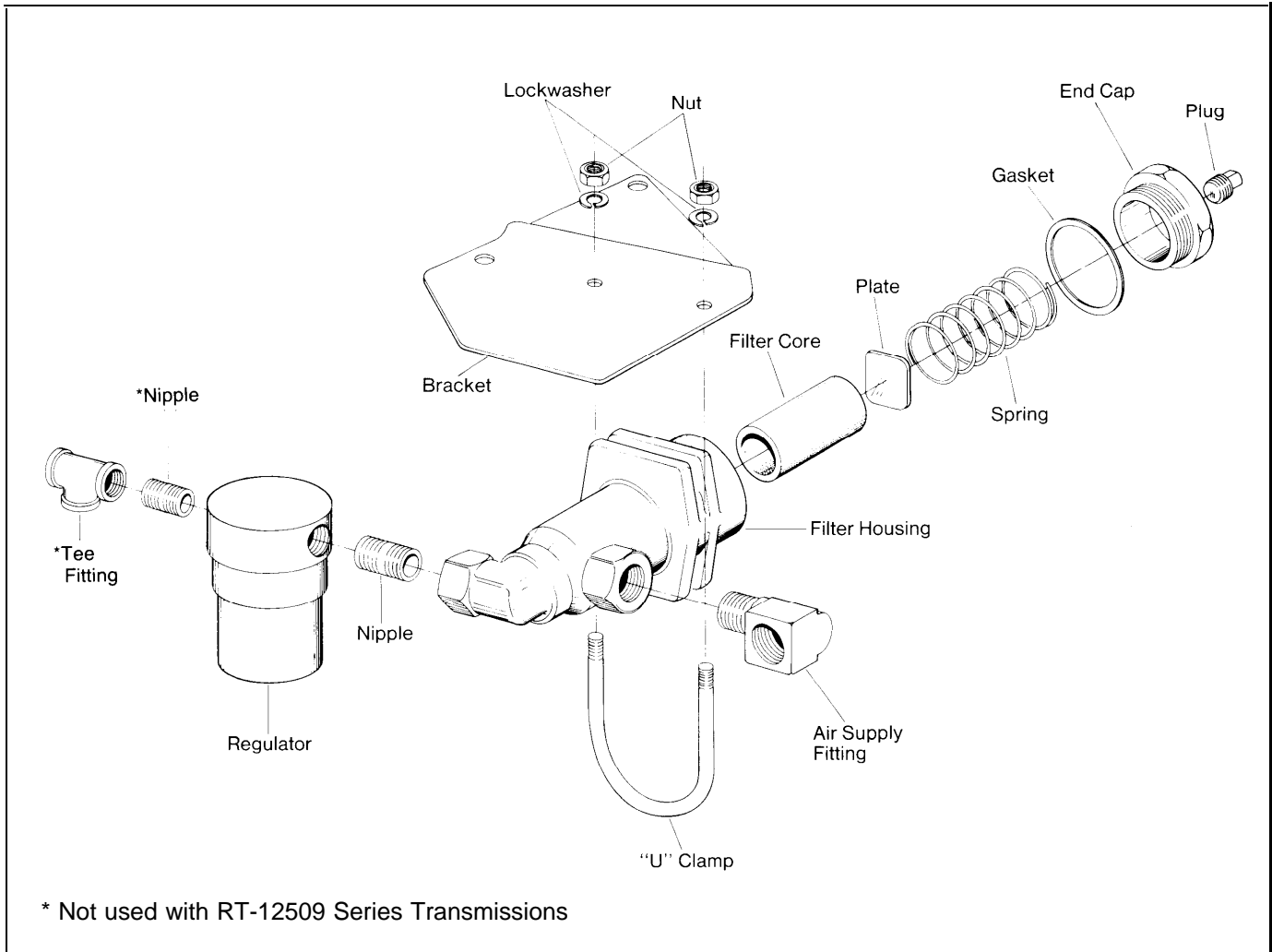

### A. REMOVAL AND DISASSEMBLY

1. Turn out the two retaining capscrews and remove the assembly from the transmission.
2. Turn out the two clamp nuts and remove the filter/regulator assembly from the bracket.
3. Remove the fittings and if necessary, turn the regulator from the filter.
4. If necessary, turn the end cap from the filter to remove the filter core. Use caution as the end cap is spring loaded.

### B. REASSEMBLY AND INSTALLATION

1. Refer to the drawing for reassembly of the air filter.
2. Secure the nipple and regulator to the "OUTLET" port of the filter. Note that the larger of the two bores on the regulator attaches to the filter.
3. Secure the filter to the bracket with the "U" clamp, nuts and lockwashers.
4. Install the two range shift air lines between the slave air valve and the range shift cylinder and secure the filter/regulator assembly to the auxiliary housing with the two capscrews.

# Shifting Controls - continued

## IX. Gear Shift Lever Housing - All Models

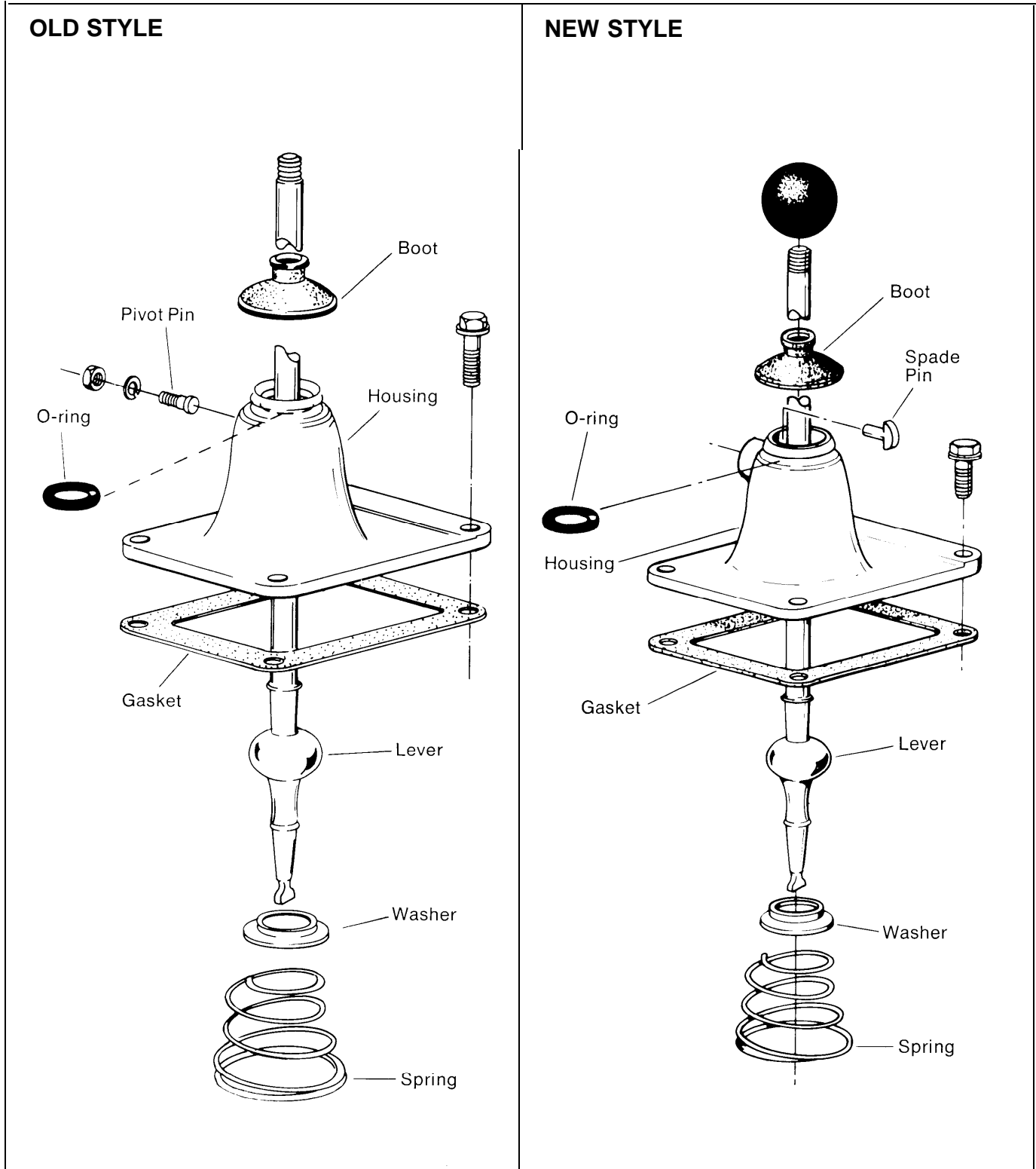

## A. REMOVAL AND DISASSEMBLY

1. Turn out the capscrews, jar lightly to break the gasket seal and remove the gear shift lever housing from the shift bar housing.



2. Secure the housing in a vise and use a large screwdriver to twist between the spring and side of the housing, forcing the spring from under the three lugs. Do one coil at a time. Remove the spring.

3. Remove the washer and gear shift lever.

4. Remove the spade pin or pivot pin, nut and washer from the bore in the housing. If necessary, remove the O-ring from the housing.

## B. REASSEMBLY AND INSTALLATION

1. Install the spade pin or pivot pin, nut and washer in the bore in the housing. If previously removed, install the O-ring in the groove.

2. Install the gear shift lever in the housing, fitting the slot in the lever ball over the spade pin.

3. Place the tension spring washer over the lever ball with the dished side up:



4. Seat the tension spring under the lugs in the housing, seating one coil at a time. Use of a spring driving tool is recommended.

5. Make sure that the three tension springs and balls are in the shift bar housing bores and install the gear shift lever housing and gasket on the shift bar housing.

# Shifting Controls - continued

## X. Shift Bar Housing - All Models

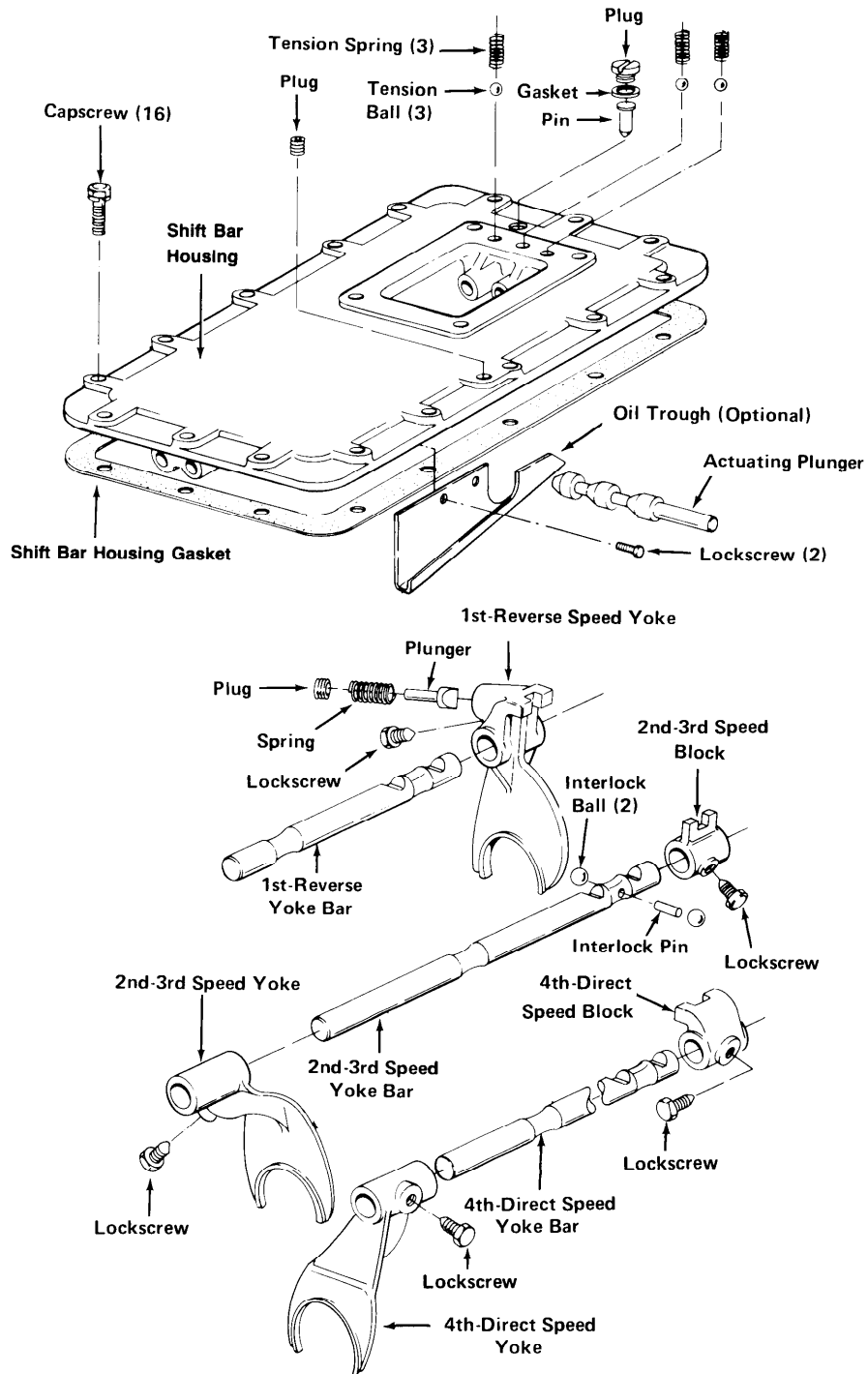

## A. REMOVAL AND DISASSEMBLY

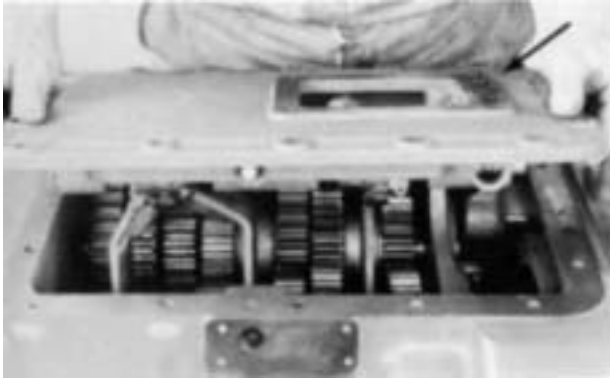

1. Make sure that the shift bars are in the neutral position. Remove the three tension springs, (arrow ). Turn out the retaining capscrews, jar lightly to break the gasket seal and lift the shift bar housing from the front case. Remove the three tension balls from the housing bores by tipping the housing slightly.

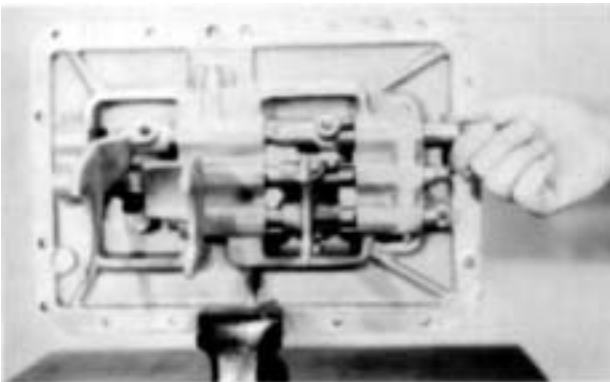

2. Mount the housing in a vise using caution to avoid marring the machined mounting surface. If so equipped, remove the oil trough. Cut and remove all of the lockwires. Turn out the lockscrews and remove the direct speed shift bar, yoke and block.

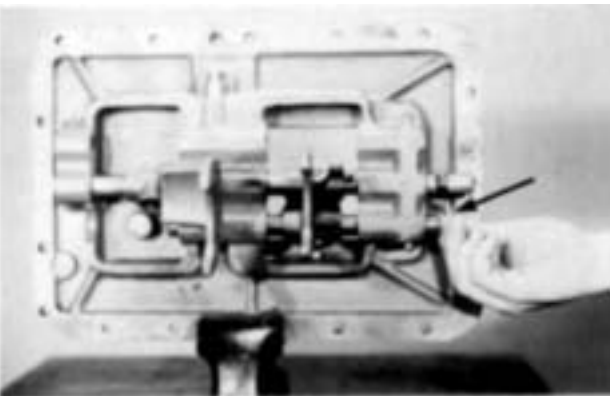

3. Turn out the lock screws and remove the 2nd speed shift bar, yoke and block. As the notch clears the housing boss, remove the interlock pin, (arrow).

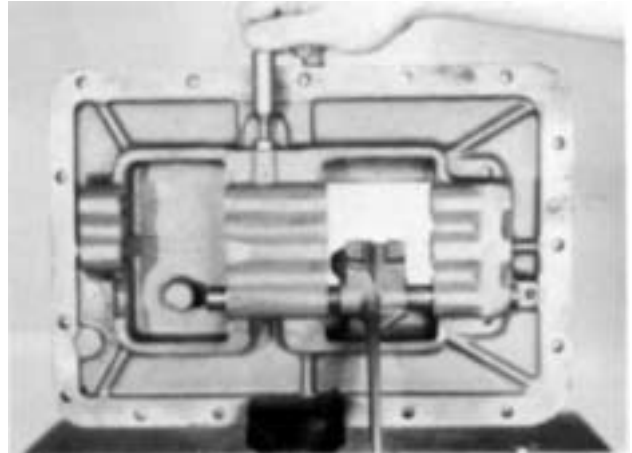

4. Remove the actuating plunger.

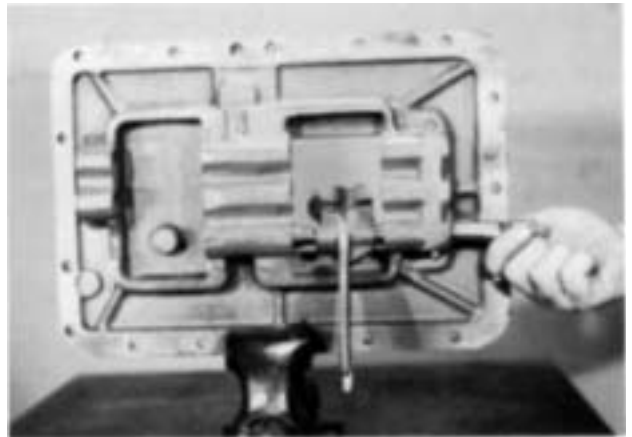

5. Turn out the lock screw and remove the reverse speed shift bar and yoke. If necessary, turn out the plug on the yoke and remove the spring and plunger. Use caution as the plug is spring loaded.

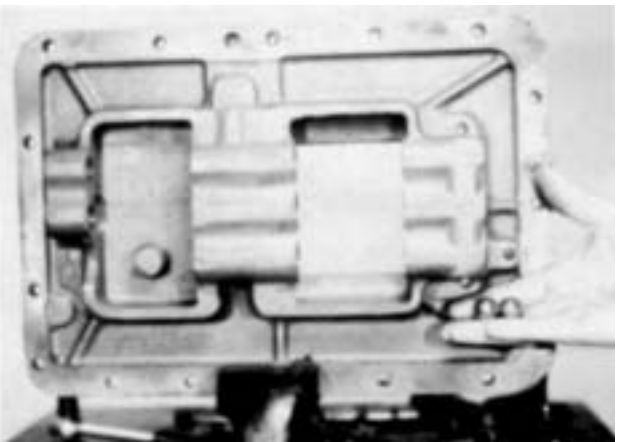

6. Remove the two interlock balls from the bore in the housing boss.

## Shifting Controls - continued

### X. Shift Bar Housing

#### B. REASSEMBLY AND INSTALLATION



1. If previously removed, install the reverse-stop plunger in the reverse yoke. Make sure that the plunger is fully seated in the bore.



2. Install the spring in the bore and on the plunger.

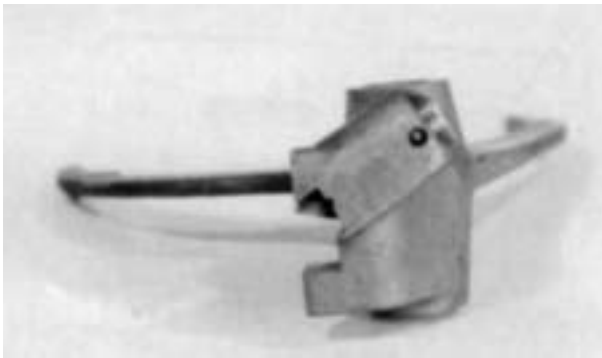

3. Apply adhesive sealant to the plug threads and partially install the plug. Use the tip of the gear shift lever to push the plunger back into the bore to compress the spring. Tighten the plug fully and then back off 1/2 - 1-1/2 turns. Stake the plug threads in the hole.

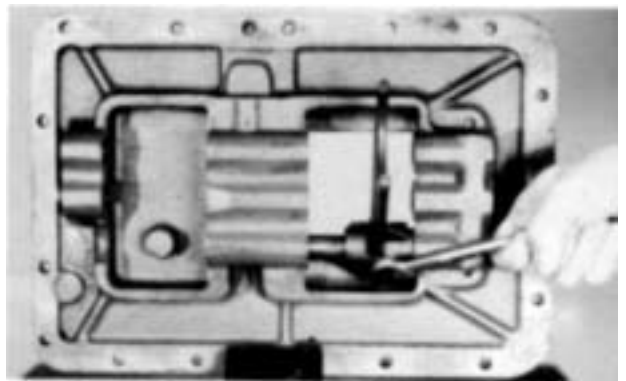

4. Install the reverse shift bar and yoke. Install the yoke lockscrew; tighten and wire securely.

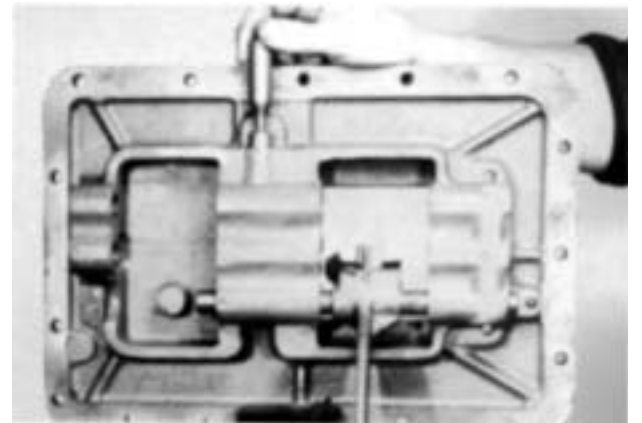

5. Install the actuating plunger.

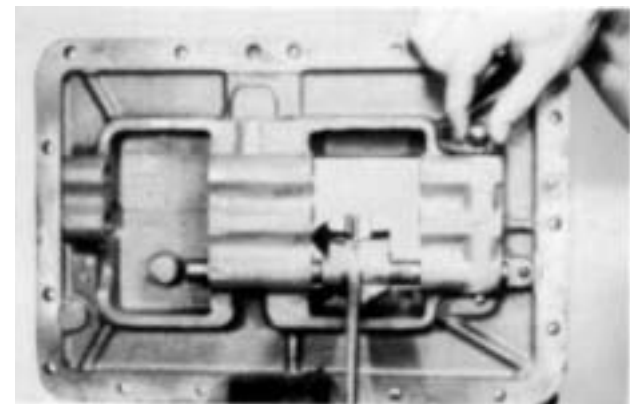

6. Install one of the two interlock balls in the housing bore, making sure that the ball goes all the way to the bottom of the bore and rests on the reverse shift bar.

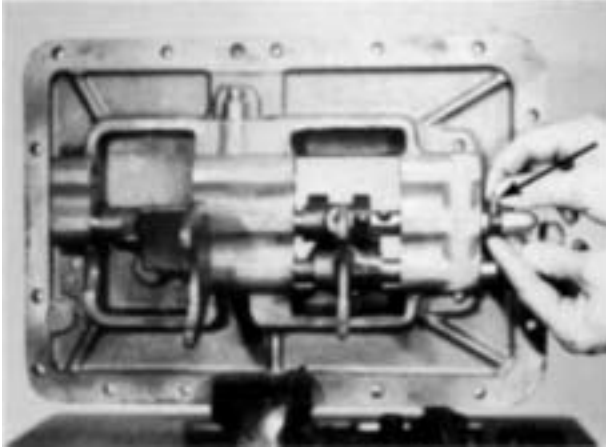

7. Install the 2nd speed shift bar, yoke and block, inserting the interlock pin in the neutral notch of the bar, (arrow). Install the yoke and block lockscrews; tighten and wire securely. On "F" model transmissions, use the short lockscrew in the shift block.



10. Install the three tension balls; one in each bore.

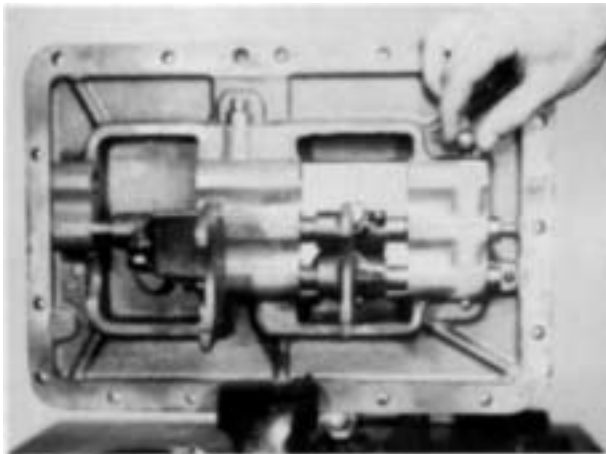

8. Install the remaining interlock ball,



11. Install the shift bar housing and gasket on the front case, fitting the yoke slots into the mainshaft sliding clutch gears. The shift bars and clutches must be in the neutral position. Install the three tension springs in the bores.

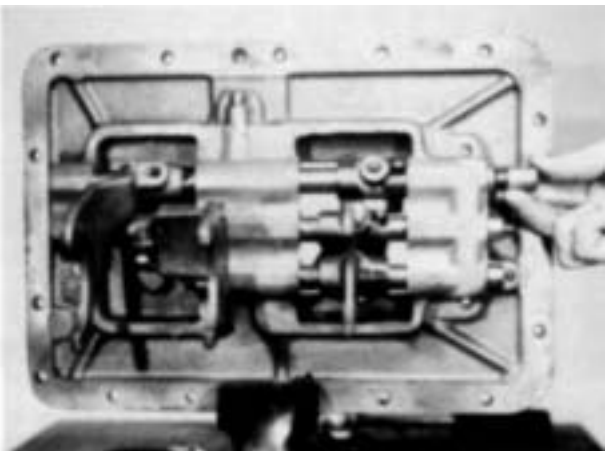

9. Install the direct speed shift bar, yoke and block. Install lockscrews and wire securely. If so equipped, install the oil trough with the two lockscrews and wire securely.

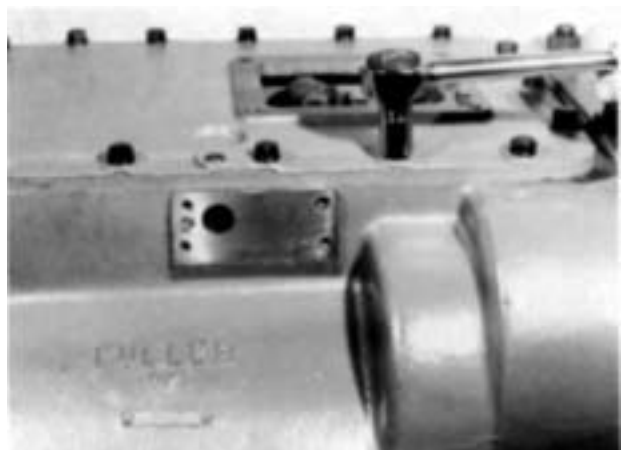

12. Secure the housing with the retaining capscrews.



# Auxiliary Sections

## I. Removal and Installation - All Models

### A. REMOVAL FROM FRONT CASE

**NOTE:**

The RT-12513 auxiliary section is shown in the following steps. However, the procedure is the same for RT-12509 series and RTO-1258LL transmissions.

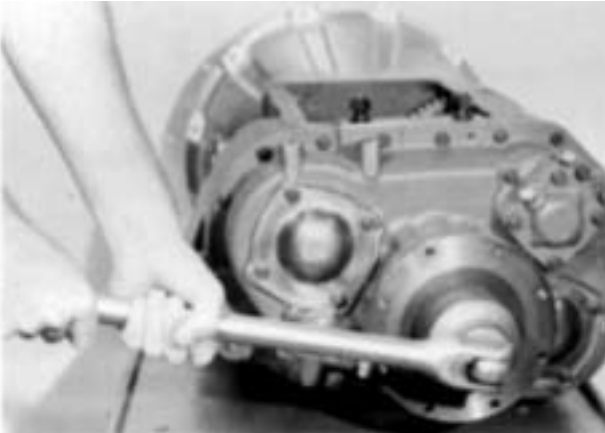

1. If not previously removed, use two clutches in the front case to lock the transmission in two gears and use a large breaker bar to turn the output shaft nut from the output shaft.



2. Remove the stop nut washer and companion flange or yoke from the splines of the output shaft.

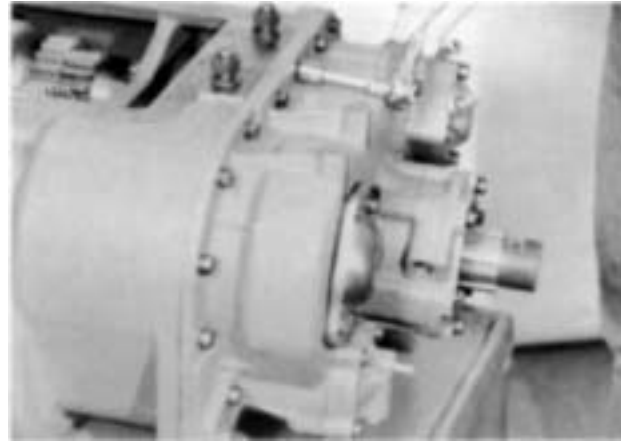

3. Turn out the capscrews securing the auxiliary section to the front case.

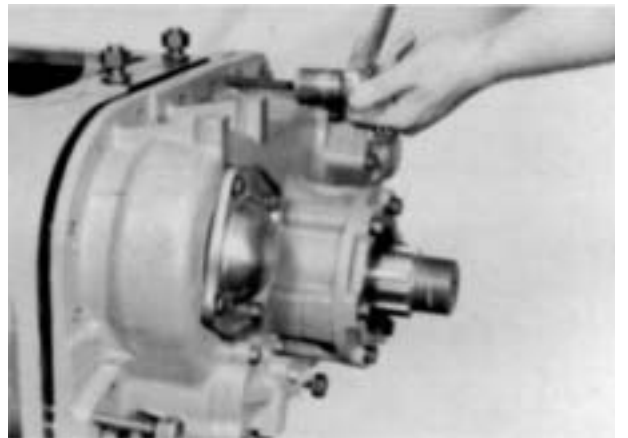

4. Insert three puller screws in the tapped holes in the auxiliary section flange and tighten evenly to move the auxiliary approximately 1/2" to the rear.



5. Attach a lifting bracket at the top center of the auxiliary section. Move the auxiliary to the rear and off the front case dowel pins. Mount the auxiliary in a vise using caution to avoid damage to the machined surface of the flange.

## B. INSTALLATION ON THE FRONT CASE

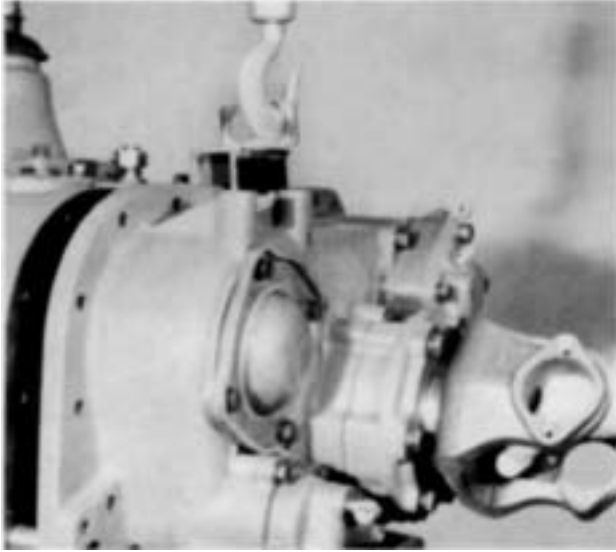

1. Install the gasket on the front case. Attach a lifting bracket and chain hoist to the top center of the auxiliary section and guide the section on to the front case dowel pins. The two auxiliary countershafts will mesh with the drive gear and the front of each shaft will seat in the two bearings installed in the front section. Move the assembly evenly, rotating the drive gear, if necessary, to properly mesh gears.

### NOTE:

The auxiliary section can also be installed by setting the front section vertically on wood blocks and lowering the auxiliary section onto the front case with a chain hoist attached to an output shaft lifting bracket. This procedure is recommended for installation of the RTO-1258LL auxiliary section due to the extreme length and weight of the countershaft assemblies.

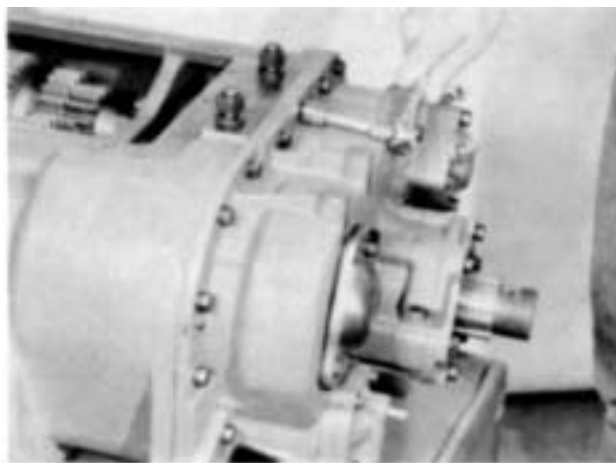

2. With the auxiliary section fully into position against the front case, install the capscrews.



3. Install the speedometer drive gear or replacement spacer on the hub of the flange or yoke. Install the flange on the splines of the output shaft.

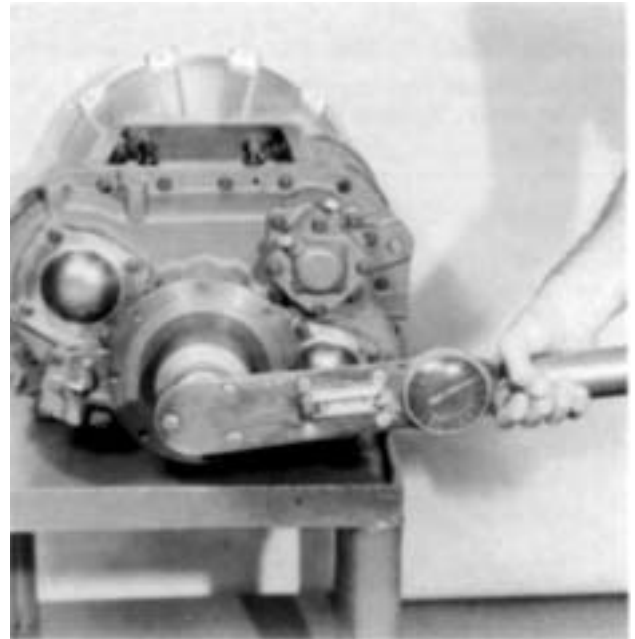

4. Lock the front case by engaging two sliding clutches and secure the flange or yoke with the elastic stop nut, using 450-500 lbs./ft. or torque. The nut should be pre-lubricated.

# Auxiliary Sections - continued

## II. RT-12509 Auxiliary Section Disassembly

### A. REMOVAL AND DISASSEMBLY OF THE RANGE SHIFT CYLINDER ASSEMBLY

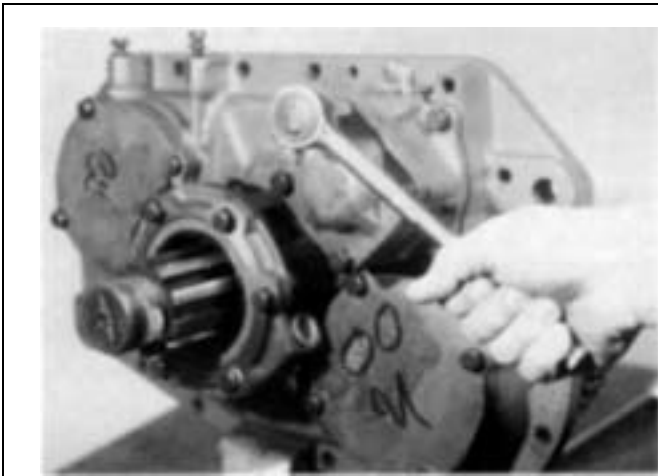
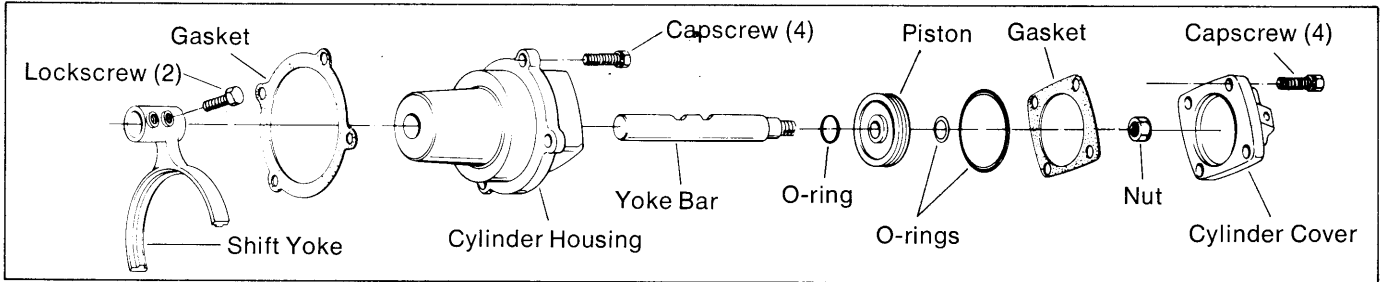

1. Turn out the four capscrews and remove the shift cylinder cover. Remove the nut from the end of the yoke bar.

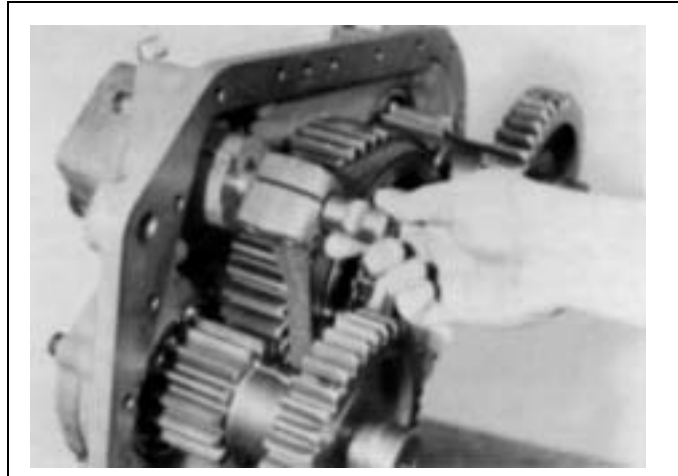

3. Pull the yoke bar forward and out of the housing. Remove the piston from the cylinder bore and if necessary, remove the O-rings from the ID and OD of the piston.

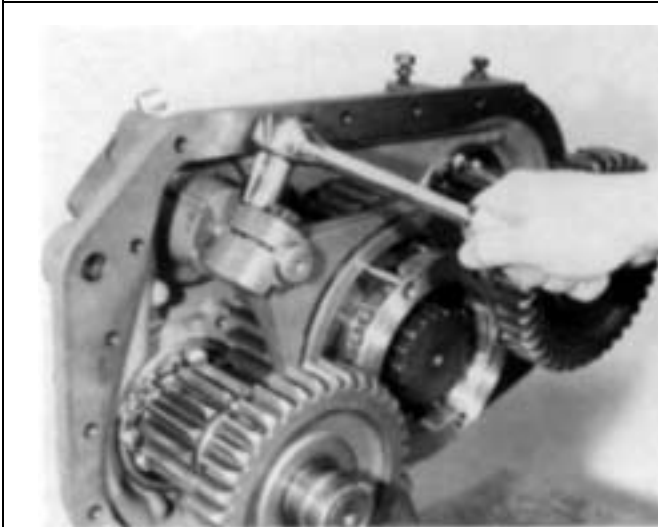

2. Cut the lockwire and turn out the two yoke lock-screws.

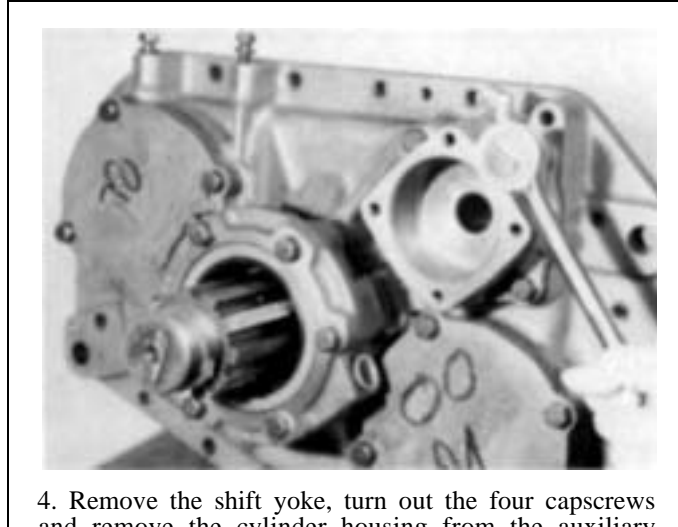

4. Remove the shift yoke, turn out the four capscrews and remove the cylinder housing from the auxiliary plate. If necessary, remove the O-ring from the bore in the housing.

## B. REMOVAL OF THE AUXILIARY COUNTERSHAFTS

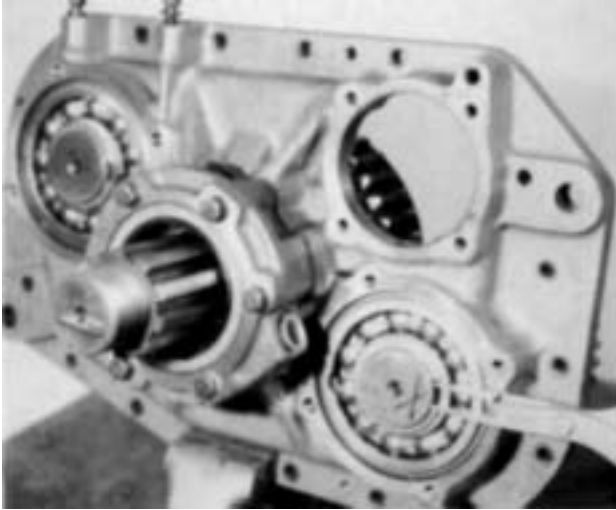

1. Turn out the capscrews and remove the two countershaft rear bearing covers. Remove the snap ring from the rear of each countershaft.



2. Use a soft bar and mallet to drive the countershafts forward and from the rear bearings. Use a soft bar to tap the bearings to the rear and from the auxiliary plate. Tap on the outer race to avoid damaging the bearings.

## C. REMOVAL AND DISASSEMBLY OF THE SYNCHRONIZER ASSEMBLY



2. Pull the synchronizer assembly forward and from the splines of the output shaft.



2. Pull the direct ring from the blocker pins of the low speed ring; cover the assembly with a cloth during this step to avoid losing the three springs which will be released from the direct ring. Remove the sliding clutch gear from the low speed ring.

## Auxiliary Sections - continued

### II. RT-12509 Auxiliary Section Disassembly

#### D. REMOVAL AND DISASSEMBLY OF THE LOW SPEED GEAR AND OUTPUT SHAFT

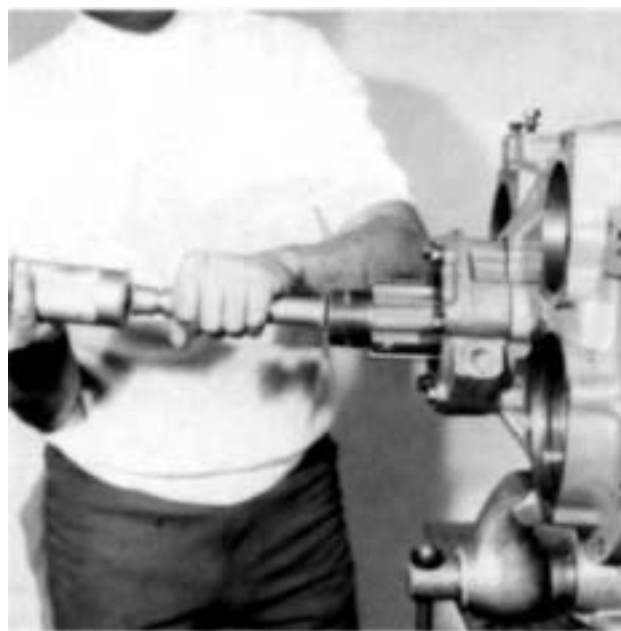
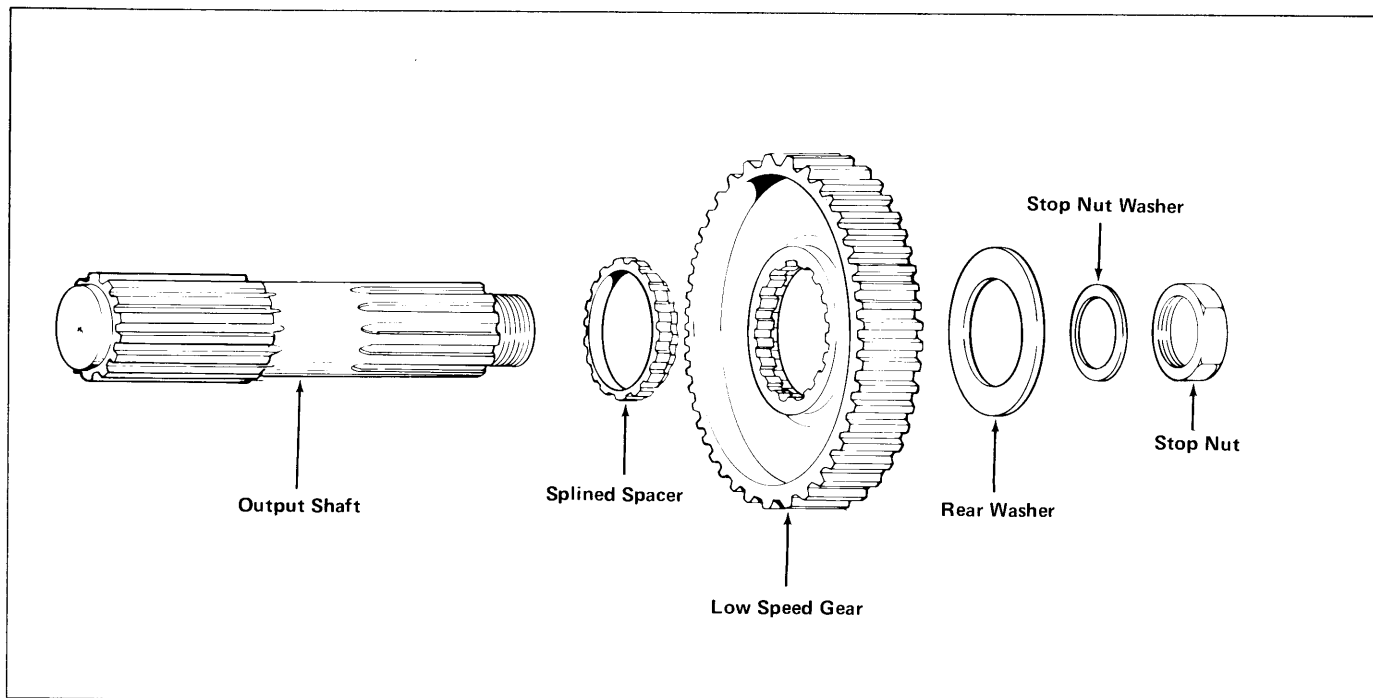

1. Use a soft bar and mallet to drive the output shaft forward and from the rear bearing.

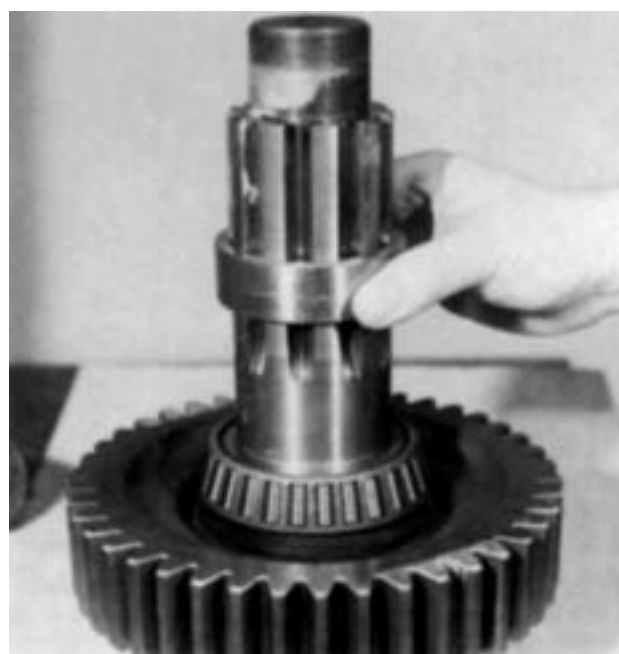

2. Remove the bearing inner spacer from the shaft.

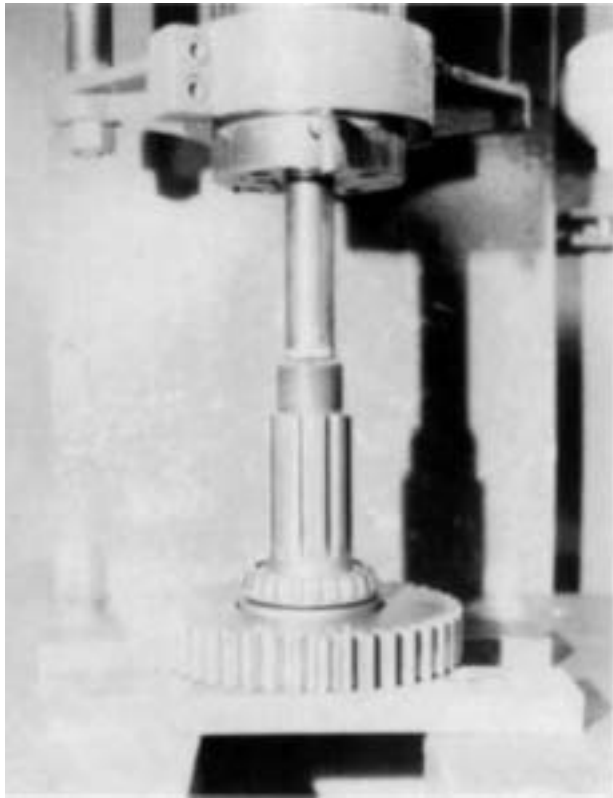

3. Using the front face of the low speed gear as a base, press the shaft through the gear and bearing. If necessary, remove the snap ring from the ID of the gear.

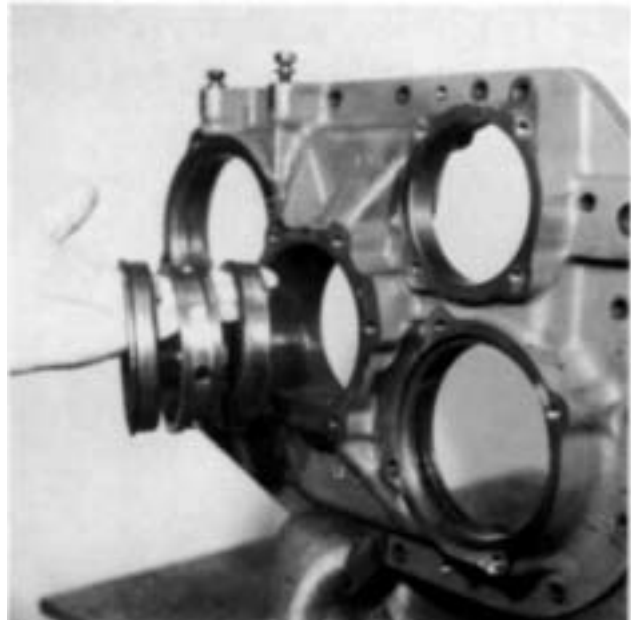

5. Remove the two bearing cups and outer spacer from the auxiliary plate bore.

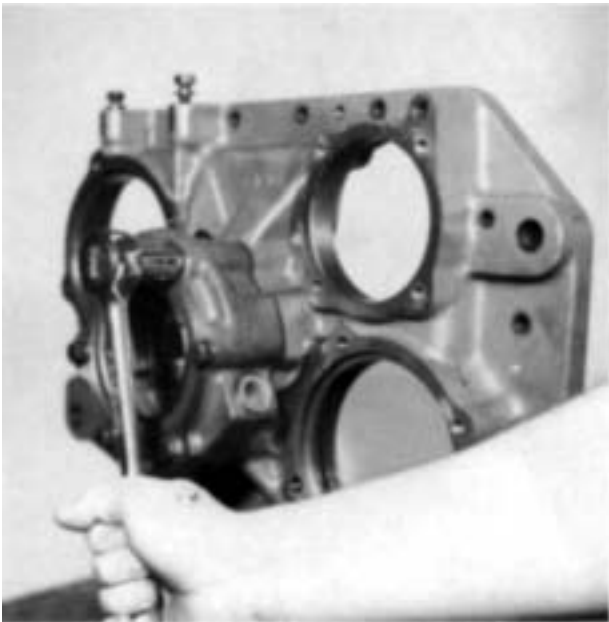

4. Turn out the cap screws and remove the rear bearing housing. If necessary, remove the oil seal from the housing. Remove the rear bearing cone from the housing.

## Auxiliary Sections - continued

### III. RT-12509 Auxiliary Section Reassembly

#### A. REASSEMBLY OF THE LOW SPEED GEAR AND OUTPUT SHAFT



1. Place the output shaft on a bench with the threaded end up and install the splined spacer on the shaft, large diameter down.

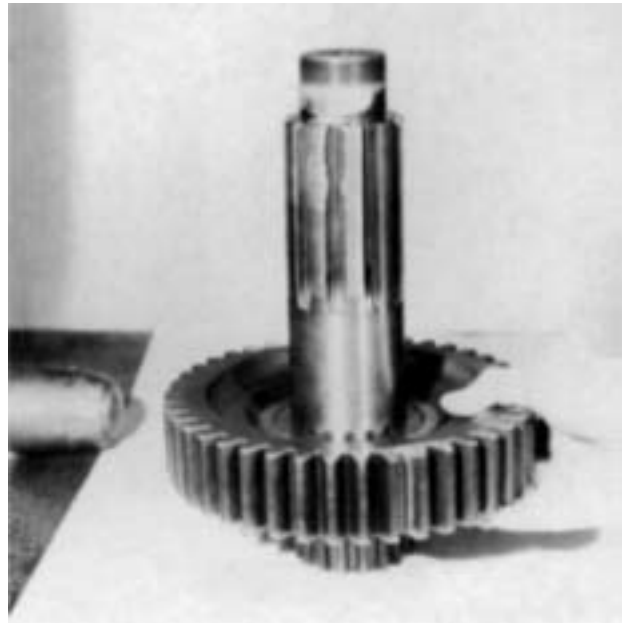

3. Install the low speed gear on the shaft with the clutching teeth down and engaging the splines of the spacer.

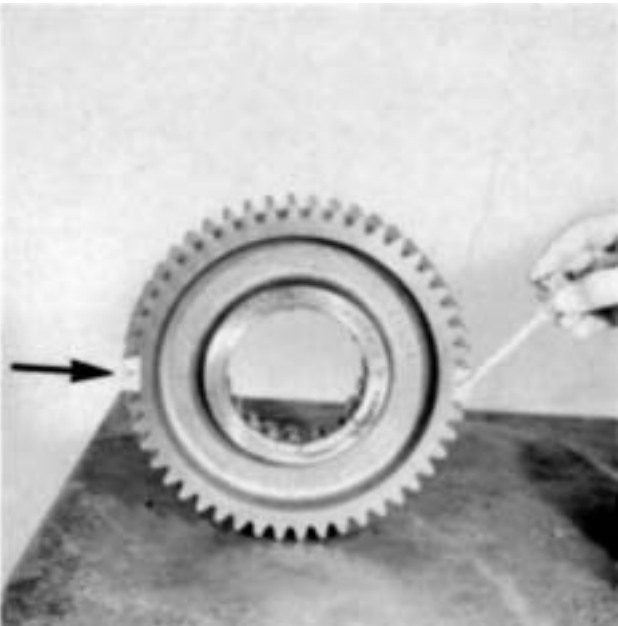

2. Mark any two adjacent teeth on the low speed gear and then mark the two teeth directly opposite.

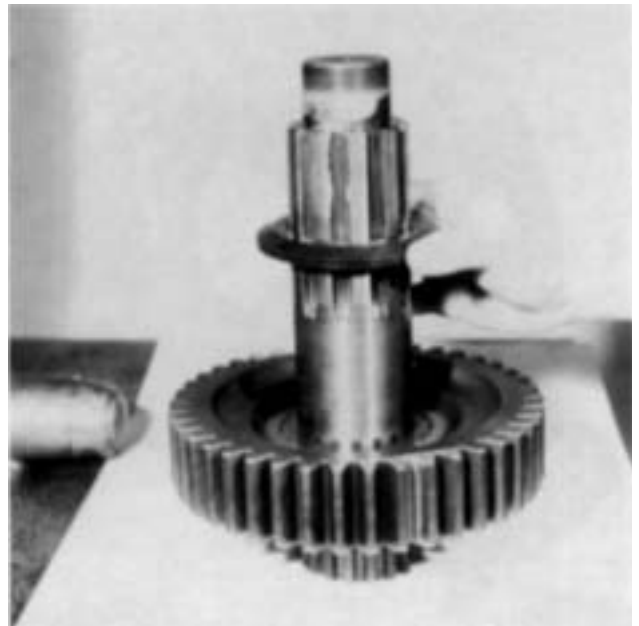

4. Install the washer on the shaft, flat surface down.



5. Heat and install the front bearing cone on the shaft and against the washer, taper up. The two bearing cones and cups are a matched set. Make sure that the correct cone for cup is used as indicated by markings.

**NOTE:**

Heating of the bearing cones is recommended, provided the bearing is not heated over 275°F. Heat lamps are recommended as a heating source.



6. Install the bearing inner spacer on the shaft and against the bearing cone.



7. Place the front cup into the housing bore with the thick end up.



8. Stack the outer spacer and i-car cup, shoulder up, on the front cup and tap all three evenly into the bore until the shoulder of the rear cup seats against the auxiliary plate.



## Auxiliary Sections - continued

### III. RT-12509 Auxiliary Section Reassembly

#### A. REASSEMBLY OF THE LOW SPEED GEAR AND OUTPUT SHAFT.



9. Heat and install the rear bearing cone, taper to the inside.

NOTE: Heating of the bearing will facilitate installation. Do not heat the bearing over 275°F.



10. If previously removed, install the oil seal in the rear bearing housing. Side with the seam to the inside.



11. Install the rear bearing housing over the output shaft and against the rear plate. If the transmission is equipped with a speedometer drive gear, the gear must be installed on the output shaft prior to the installation of the rear bearing housing. Use a brass washer on the capscrew intersecting the speedometer drive gear bore.

## B. REASSEMBLY OF THE SYNCHRONIZER ASSEMBLY

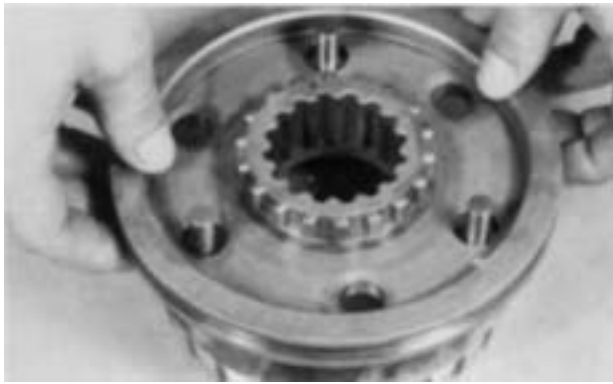

1. Place the larger (low speed) brass synchronizer ring on a bench with the pins facing up and install the sliding clutch gear over the ring, protruding clutching teeth down.



4. Apply pressure to the direct ring while twisting counterclockwise to fully seat the direct ring on the low speed ring pins.

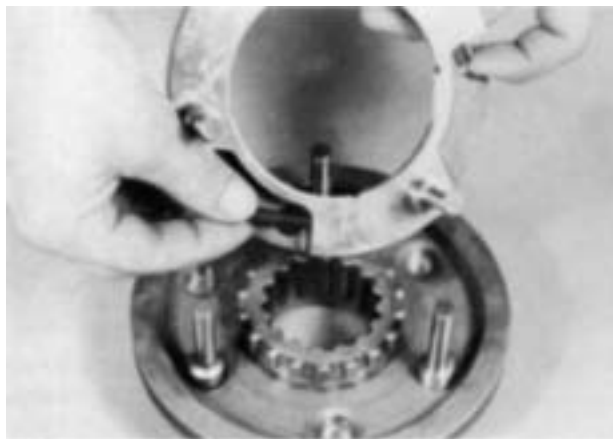

2. Install the three springs in the direct ring,

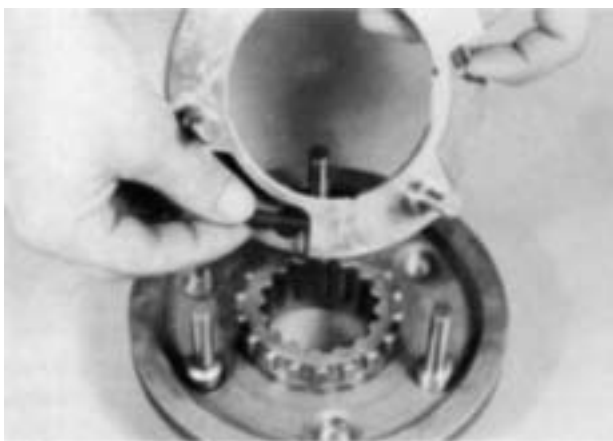

3. Install the direct ring on the low speed ring pins, seating the springs against the pins.

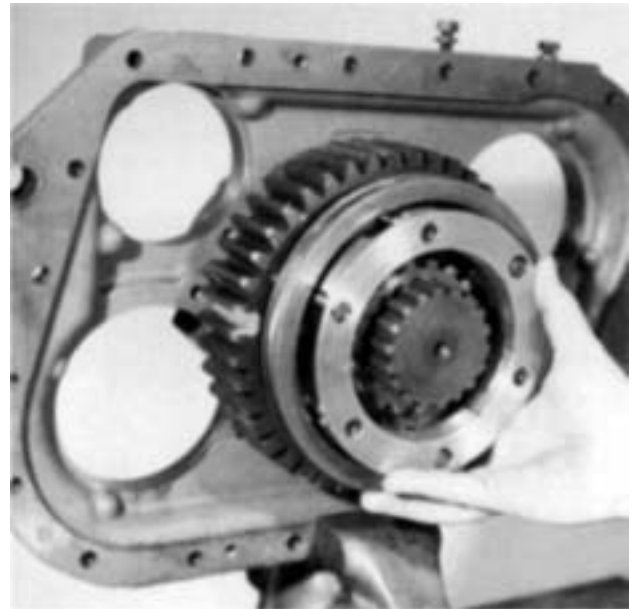

5. Mount the auxiliary plate in a vise in the upright position and install the synchronizer assembly on the output.

## Auxiliary Sections - continued

### III. RT-12509 Auxiliary Section Reassembly

#### C. TIMING AND INSTALLATION OF THE AUXILIARY COUNTERSHAFT ASSEMBLIES



1. On the small diameter low range gear of each countershaft, mark the tooth which is stamped with an "O".

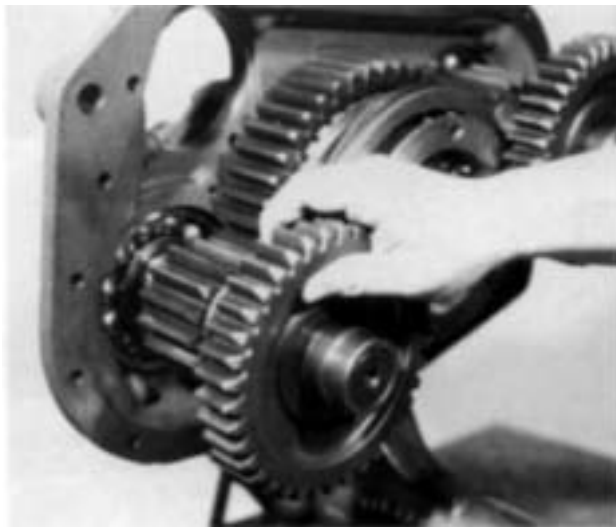

2. Place one of the countershafts into position in the rear plate, meshing the marked tooth on the countershaft between two of the marked teeth on the low speed gear. Use a soft bar to start the rear bearing onto the shaft and into the case bore and use a bearing driver to complete the installation. Check the synchronizer assembly during bearing installation to make sure that the springs do not pop out. Repeat the procedure for the remaining countershaft.

NOTE: Make sure that the bearing inner race is installed on the front of each auxiliary countershaft.

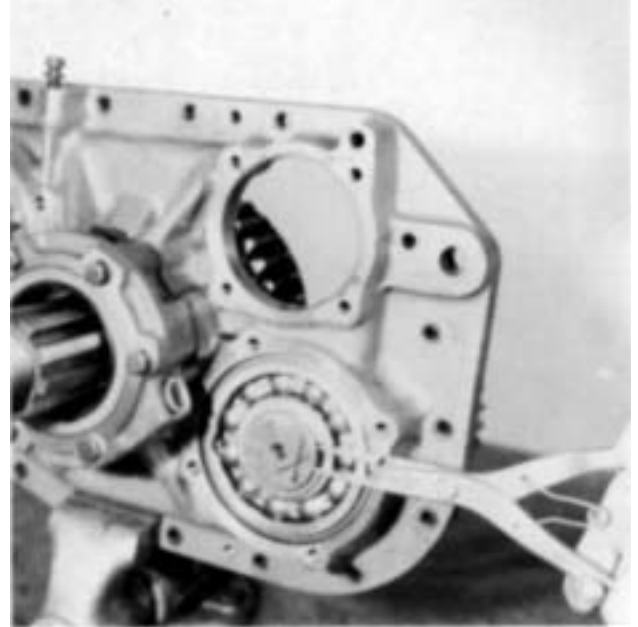

3. Install the snap ring on the rear of each countershaft.

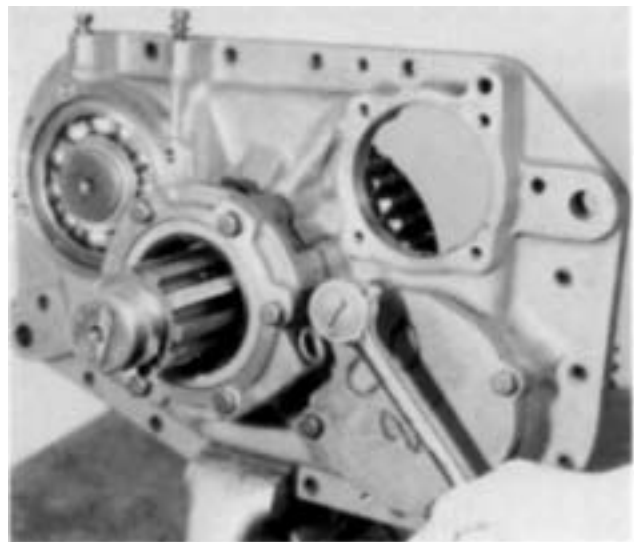

4. Install the countershaft rear bearing covers.

## D. INSTALLATION OF THE RANGE SHIFT CYLINDER ASSEMBLY

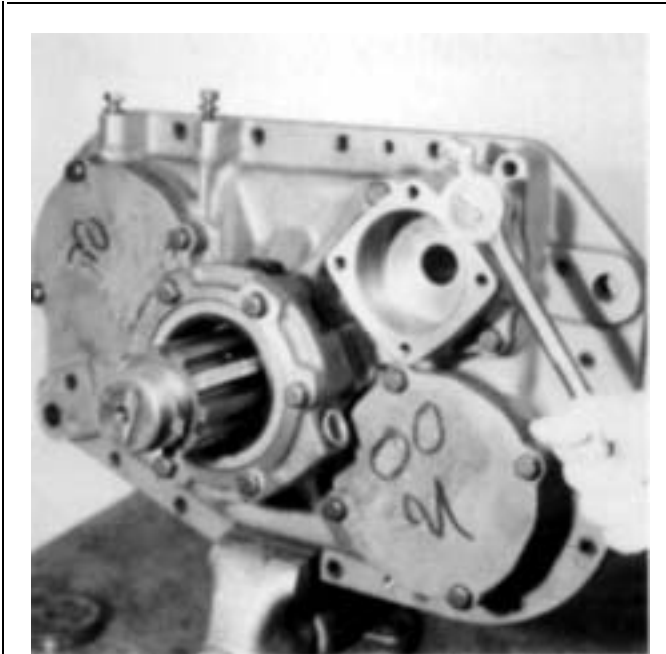

1. Install the cylinder housing and gasket in the rear plate with the air fitting facing up. If previously removed, install the O-ring in the bore in the cylinder and coat the O-ring with a thin application of silicone lubricant.



3. Install the O-rings in the OD and ID of the piston, apply a thin coat of silicone lubricant to the O-rings and install the piston on the yoke bar and in the cylinder housing bore with the flat side facing out.

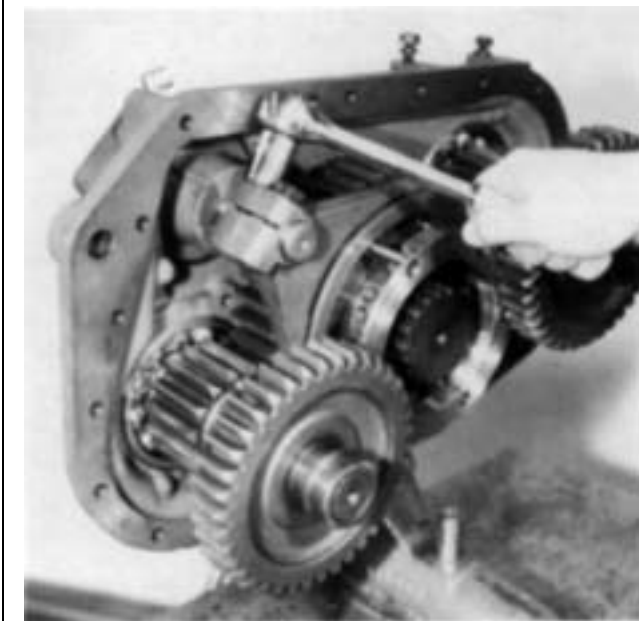

2. Install the shift yoke on the sliding clutch gear of the synchronizer and insert the yoke bar through the yoke and cylinder housing. Secure the yoke to the bar with the two yoke lockscrews; tighten and wire securely.

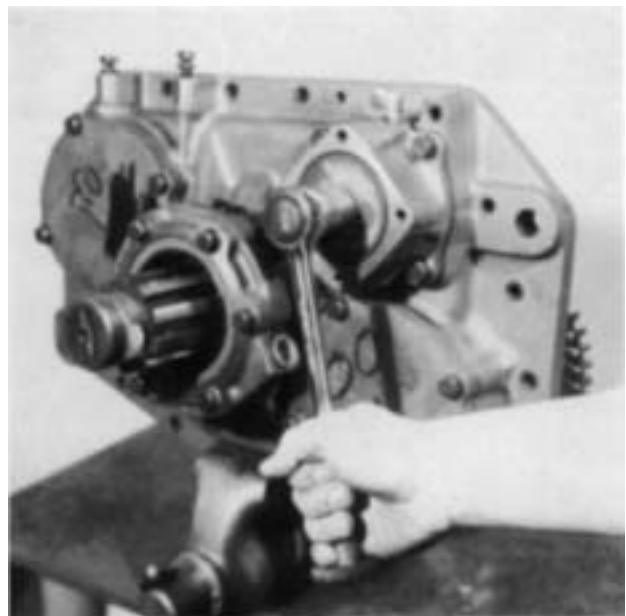

4. Secure the piston to the yoke bar with the nut. Install the gasket and cover with the air fitting to the top.

# Auxiliary Sections - continued

## IV. RTO-1258LL Auxiliary Section Disassembly

### A. REMOVAL AND DISASSEMBLY OF THE RANGE SHIFT CYLINDER ASSEMBLY

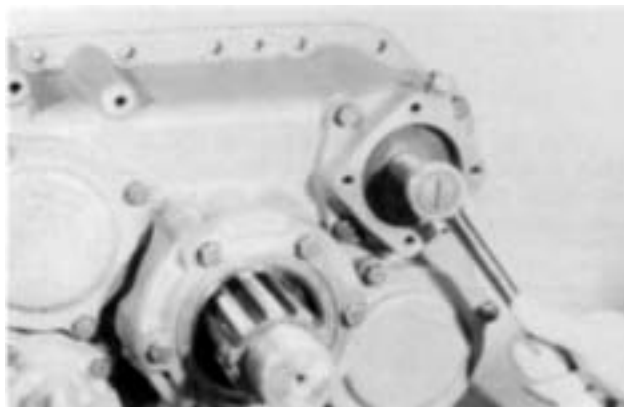
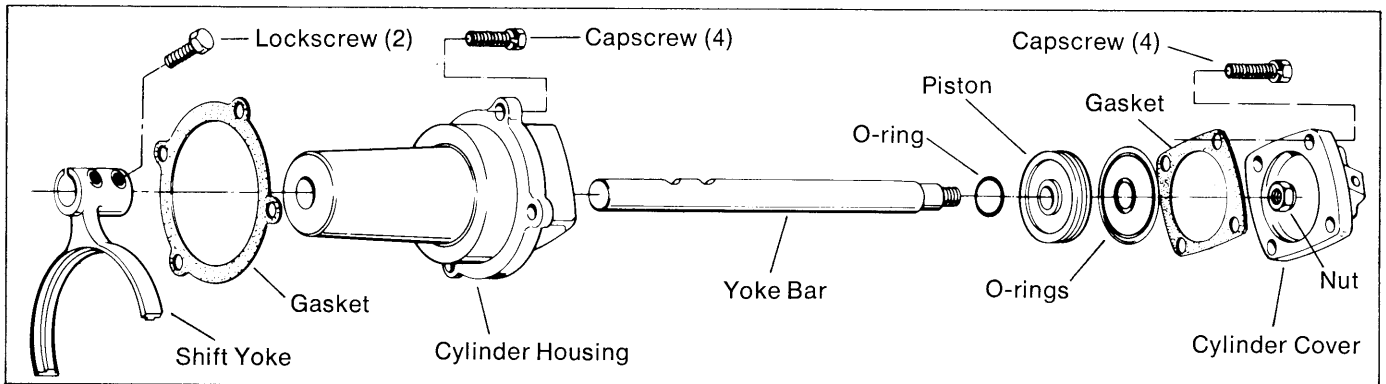

1. Turn out the four capscrews and remove the range shift cylinder cover. Remove the nut from the end of the yoke bar.



3. Remove the piston from the yoke bar and if necessary, remove the O-rings from the ID and OD of the piston. Push the yoke bar forward and from the housing.

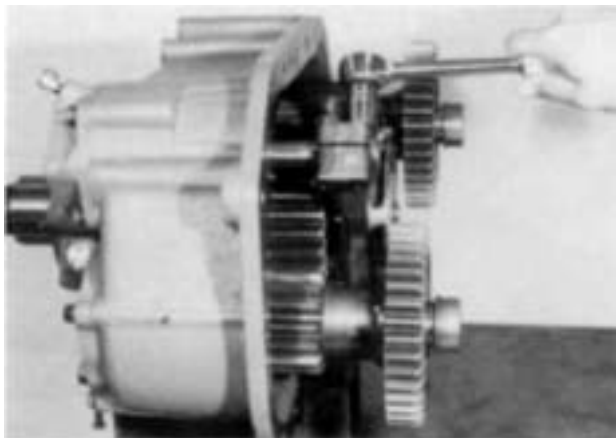

2. Cut the lockwire and turn out the two yoke lock-screws.



4. Remove the shift yoke, turn out the four capscrews and remove the cylinder housing from the auxiliary housing. If necessary, remove the O-ring from the bore in the cylinder housing.

## B. REMOVAL OF THE AUXILIARY COUNTERSHAFTS



1. Turn out the capscrews and remove the two countershaft rear bearing covers. Remove the snap ring from the rear of each countershaft.

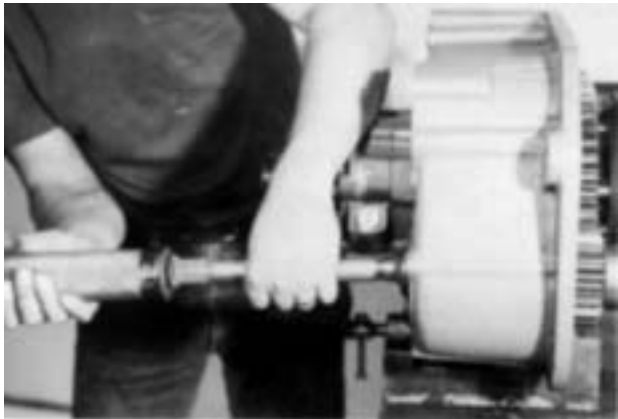

2. Use a soft bar and mallet to drive each countershaft forward and from the rear bearing. Use a soft bar to tap the bearings to the rear and from the housing bores. Tap on the outer races to avoid damaging the bearings.

### NOTE:

When driving the countershafts, check the synchronizer assembly periodically to make sure that the direct ring is not moving forward. If the direct ring is allowed to slide off the low speed ring blocker pins, the three springs in the assembly could jump out of the bores and get lost.

## C. REMOVAL AND DISASSEMBLY OF THE SYNCHRONIZER ASSEMBLY

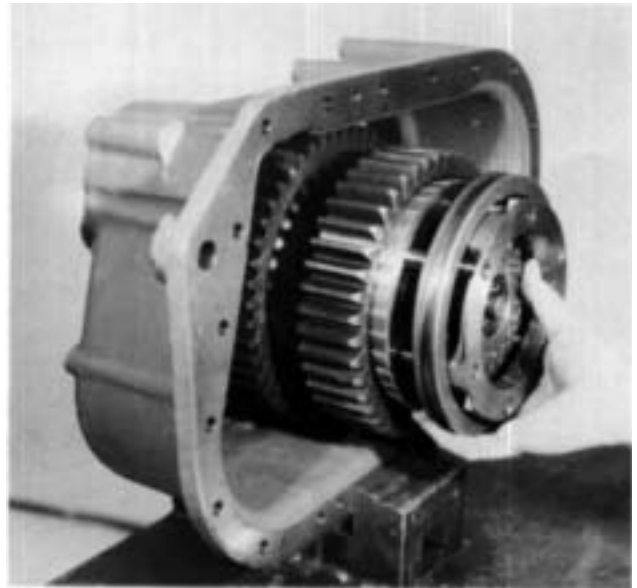

1. Pull the synchronizer assembly from the splines of the range mainshaft.



2. Pull the direct ring from the blocker pins of the low speed ring. Cover with a cloth as the three pins will be released at the blocker pin locations. Remove the sliding clutch gear from the pins of the low speed ring.

## Auxiliary Sections - continued

### III. RTO-1258LL Auxiliary Section Disassembly D. REMOVAL OF THE LOW SPEED GEAR

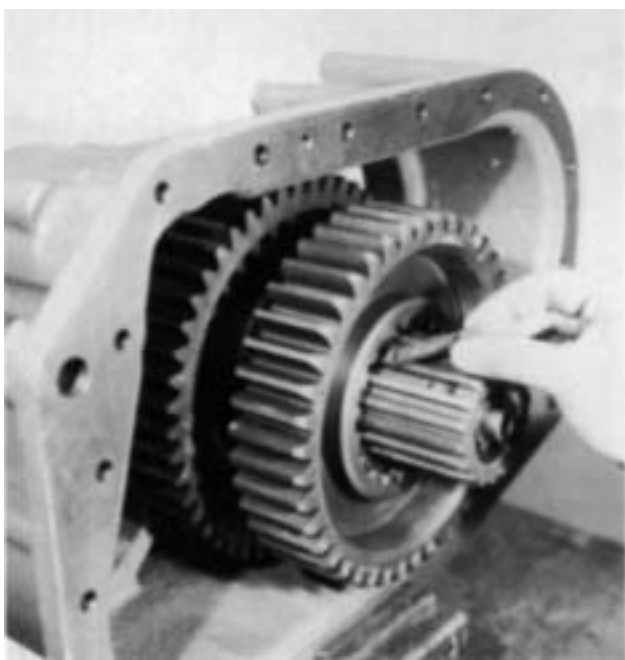
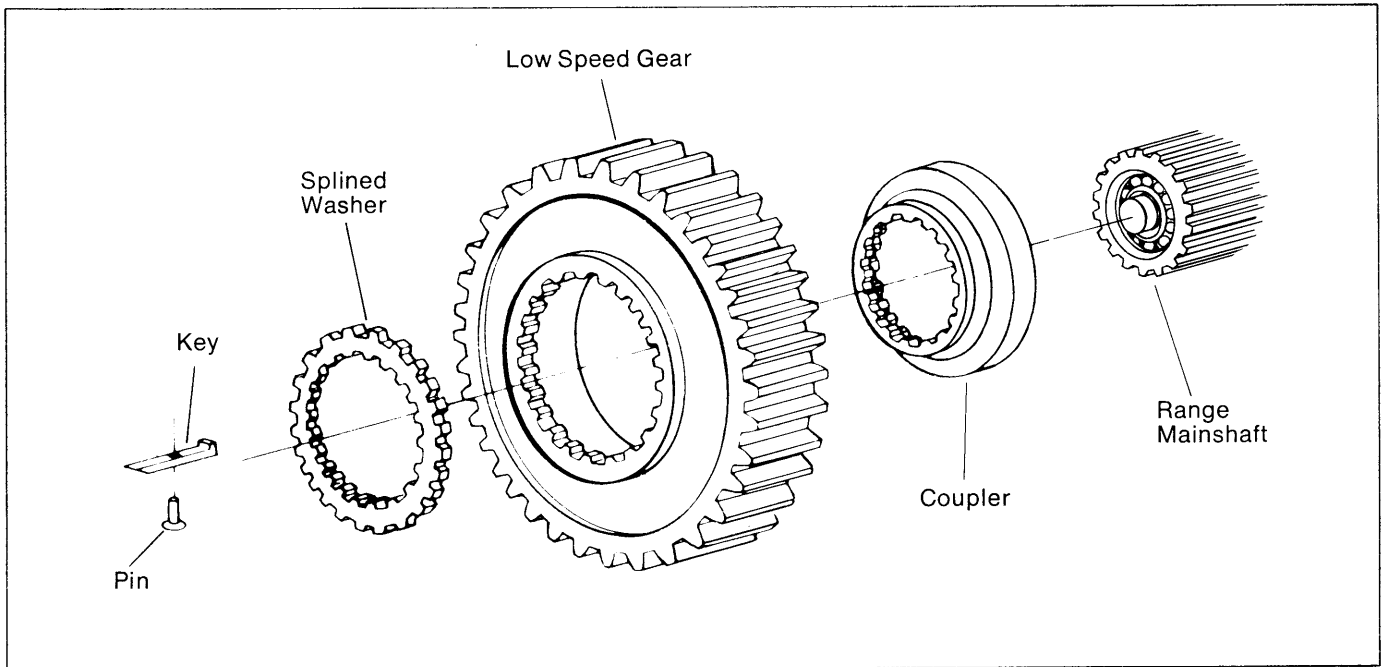

1. Remove the key from the keyway between the splines of the range mainshaft.

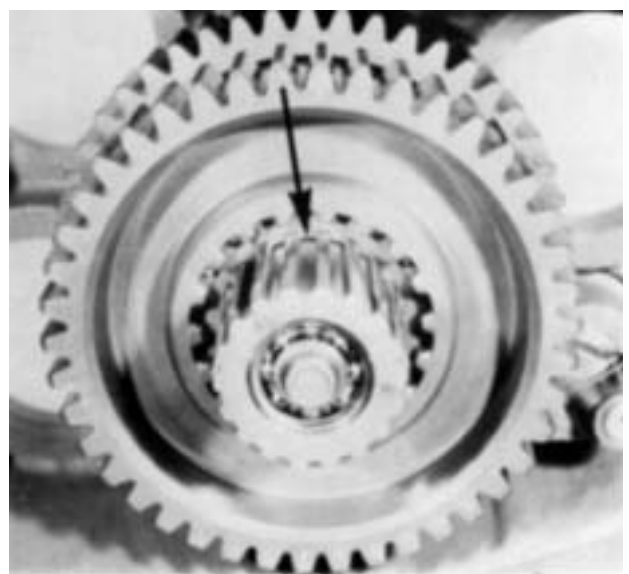

2. Turn the splines of the low speed gear washer, located in the hub of the gear, to align with the spline of the shaft. Remove the gear and washer from the shaft. Remove the coupler which is located on the shaft behind the gear.

## E. REMOVAL OF THE DEEP REDUCTION SHIFT CYLINDER

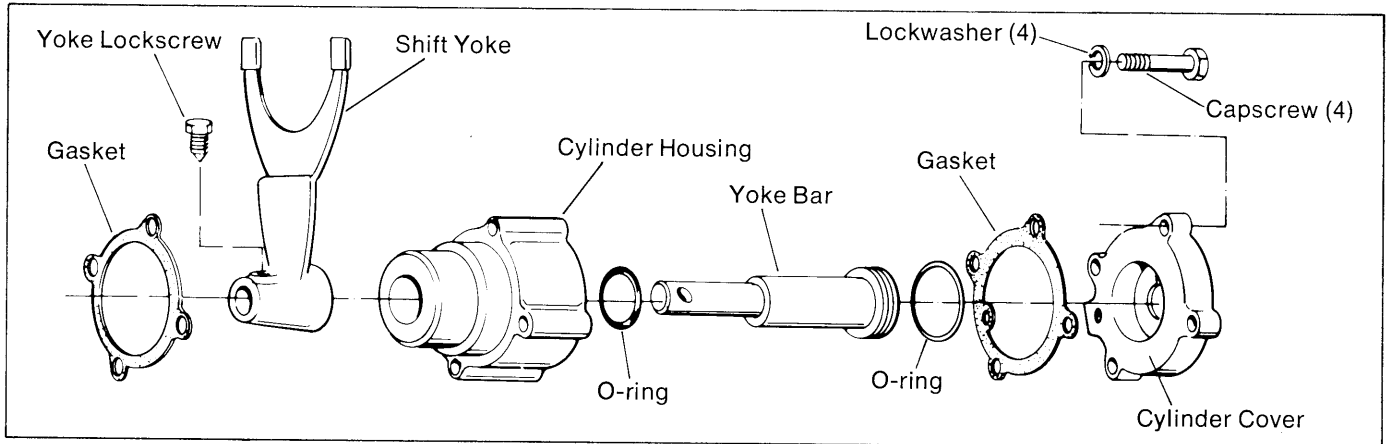

1. Remove the shift cylinder cover.



3. Push the yoke bar to the rear and remove from the housing. If necessary, remove the O-ring from the bar, (arrow).

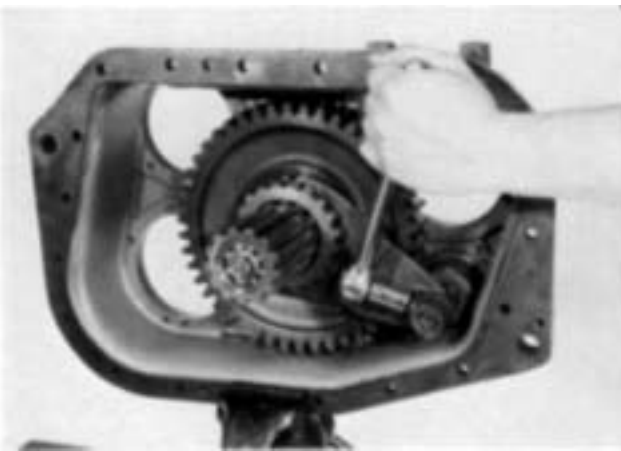

2. Cut the lockwire and turn out the lockscrew from the shift yoke.



4. Remove the shift yoke and cylinder housing from the auxiliary housing. If necessary, remove the O-ring from the bore in the cylinder housing.



## Auxiliary Sections - continued

### IV. RTO-1258LL Auxiliary Section Disassembly F. REMOVAL OF THE RANGE MAINSHAFT

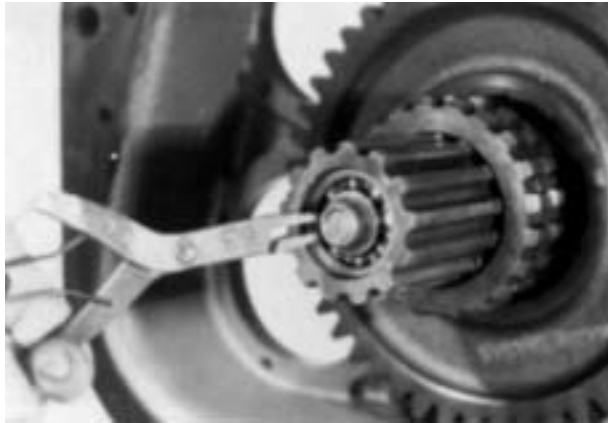
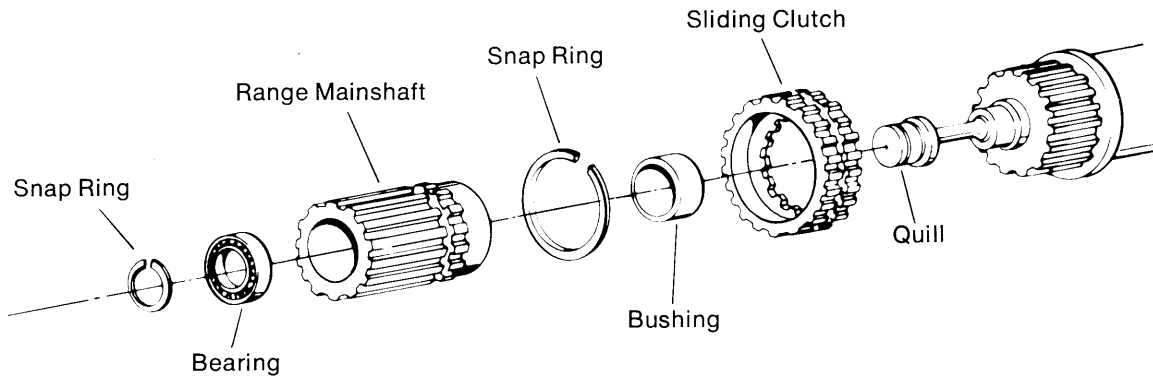

1. Remove the snap ring from the front of the quill.  
NOTE: Snap ring used on current production models must be removed by spreading with a screwdriver.



3. Remove the bearing from the shaft. If necessary, use an inside jaw impact puller.



2. Move the sliding clutch forward and against the snap ring of the range mainshaft. Insert jaws of puller behind sliding clutch gear and pull the mainshaft from the quill.

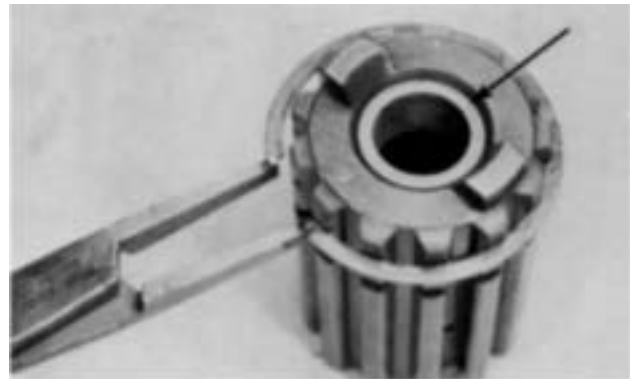

4. Remove the snap ring from the OD of the mainshaft and, if necessary, press the bushing from the mainshaft bore, (arrow).

## G. REMOVAL OF THE DEEP REDUCTION GEAR AND OUTPUT SHAFT ASSEMBLY



1. Turn out the capscrews and remove the rear bearing housing. If necessary, remove the oil seal from the housing.



2. Remove the snap ring from the output shaft.

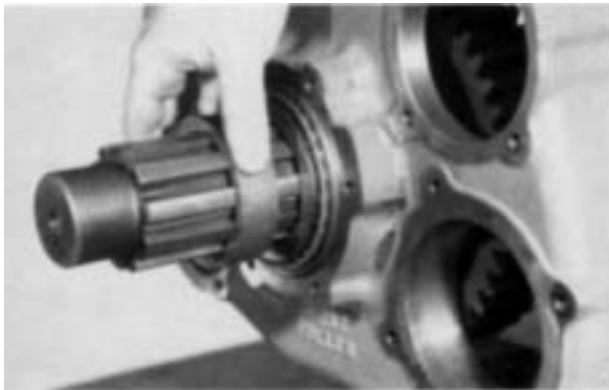

3. Remove the speedometer drive gear or replacement spacer from the shaft.

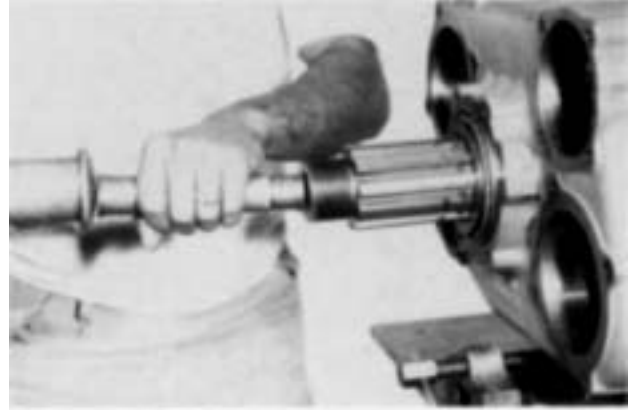

4. Use a soft bar and mallet to drive the output shaft forward and from the auxiliary housing.

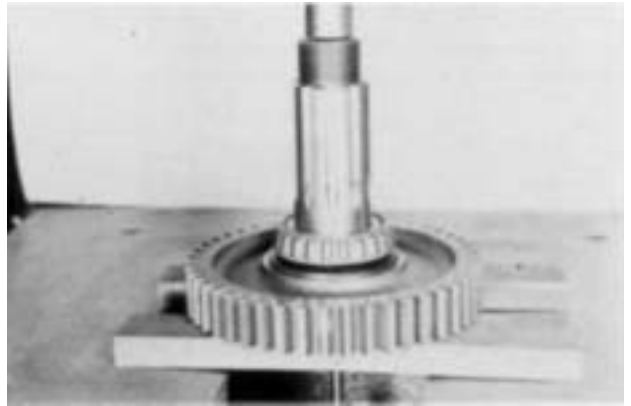

5. Use the deep reduction gear as a base to press the rear bearing from the output shaft. This will free the gear, washer, spacer and oil deflector.



6. Remove the two bearing cups and outer spacer the auxiliary housing bore.

## Auxiliary Sections - continued

### V. RTO-1258LL Auxiliary Section Reassembly

#### A. REASSEMBLY OF THE DEEP REDUCTION GEAR AND OUTPUT SHAFT

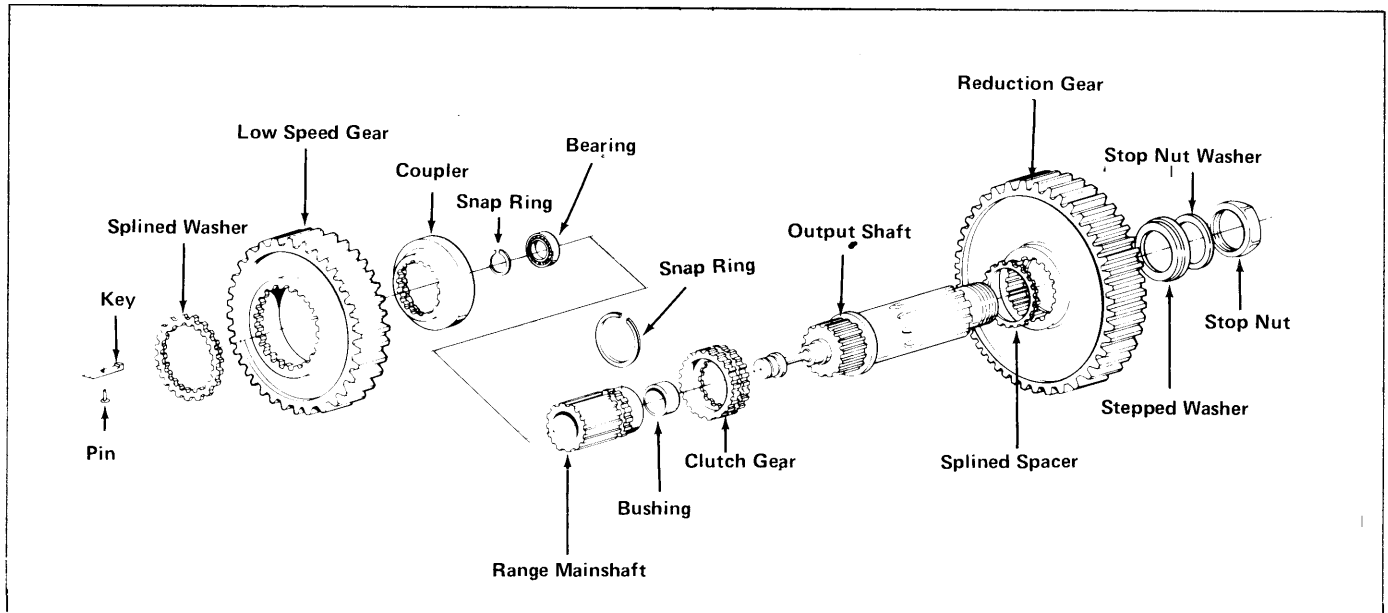

1. Place the output shaft on blocking with the threaded end up. Use caution to avoid damage to the quill.



2. Install the splined spacer on the shaft.

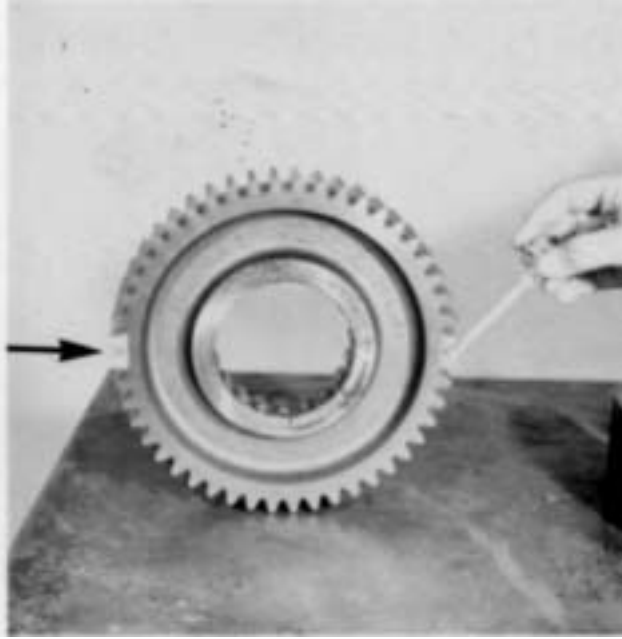

3. Mark any two adjacent teeth on the reduction gear and then mark the two teeth directly opposite.



5. Install the washer on the shaft and against the gear with the side with the large groove facing up.

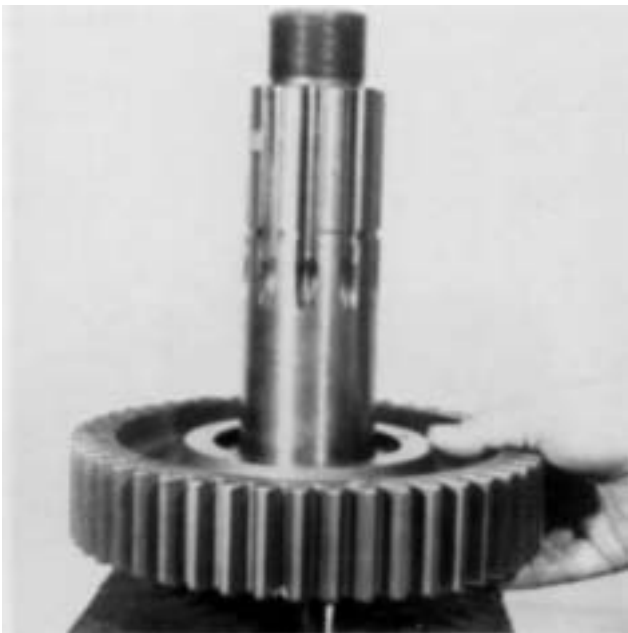

4. Install the reduction gear on the shaft and spacer with the clutching teeth down.

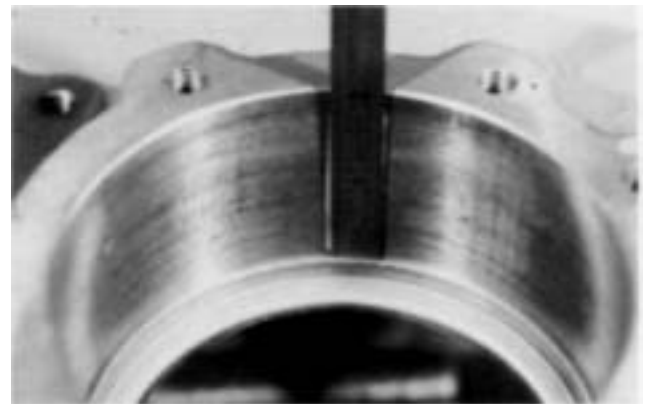

6. Install the oil deflector in the rear housing bore with the cupped surface facing up. Use a large bearing driver to drive the deflector down until the top surface of the deflector is 2" below the machined surface of the output shaft bore.

NOTE: If available, use two bearing outer spacers stacked on top of each other to drive the oil deflector into the bore. The deflector will be at the proper depth when the top of the top spacer is flush with the machined surface of the output shaft bore.

## Auxiliary Sections - continued

### V. RTO-1258LL Auxiliary Section Reassembly

#### A. REASSEMBLY OF THE DEEP REDUCTION GEAR AND OUTPUT SHAFT (Cont.)



7. Install the rear housing over the output shaft, allowing the housing to rest on the reduction gear.

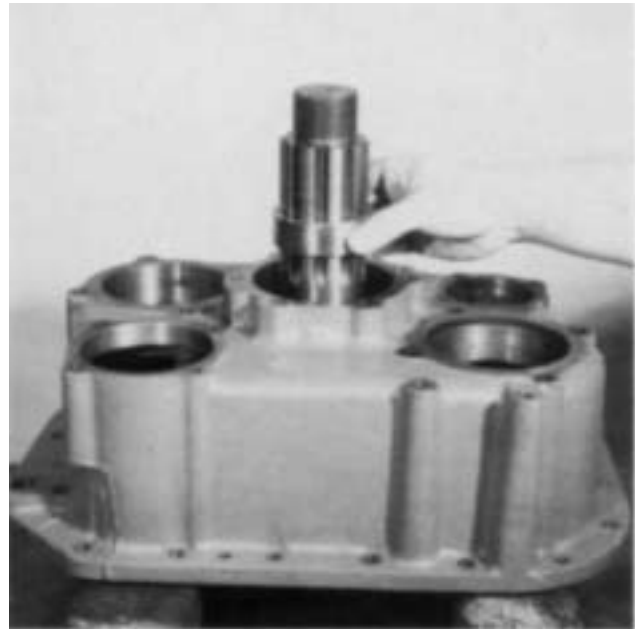

9. Install the bearing inner spacer on the shaft and against the front bearing cone.

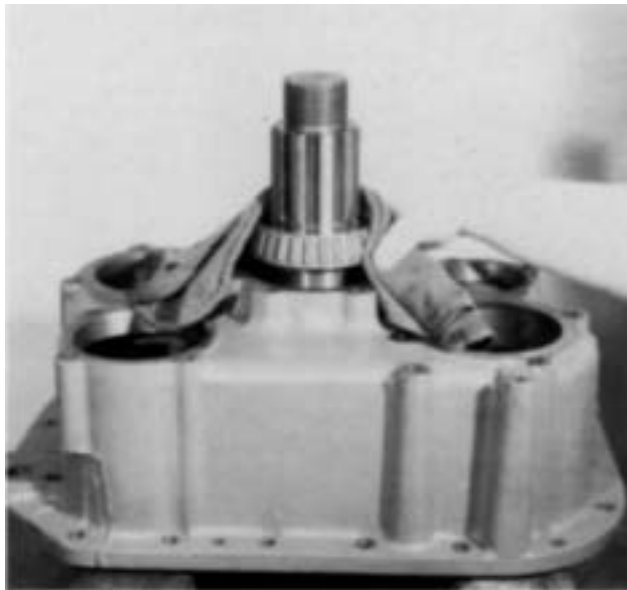

8. Heat the front bearing cone and install in the bore and against the oil deflector with the cone surface facing up.

NOTE: Heating off the bearings will facilitate installation. Do not heat the bearings over 275°F.



10. Stack the two bearing cups and outer spacer in the output shaft bore in the proper sequence. Make sure that the front bearing cup taper matches the taper direction of the front bearing cone.



11. Tap the two cups and outer spacer lightly and evenly into the case bore until the lip of the rear cup seats against the machined surface. It will be necessary to block under the rear housing slightly to permit the output shaft assembly to move far enough.

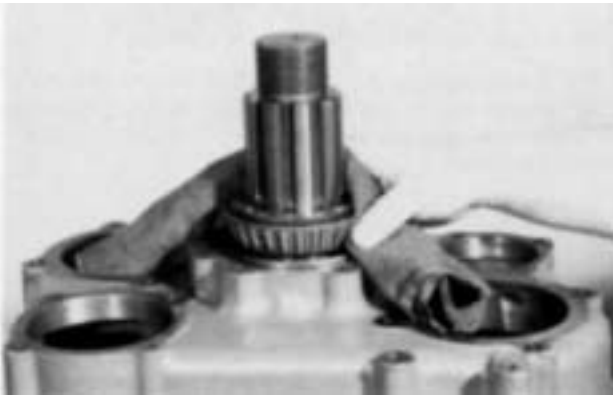

12. Heat and install the rear bearing cone on the shaft and in the rear cup, taper facing down.



13. Install the speedometer drive gear or replacement spacer on the shaft and against the rear bearing cone and secure with the snap ring.



14. If previously removed, install the oil seal in the rear bearing housing with the seam to the inside. Use of a proper oil seal driver is recommended.



15. Install the rear bearing housing and gasket on the auxiliary housing, using a brass washer (arrow), at the speedometer bore. Make sure to match one of the notches in the surface of the bearing housing with the oil port in the auxiliary housing.

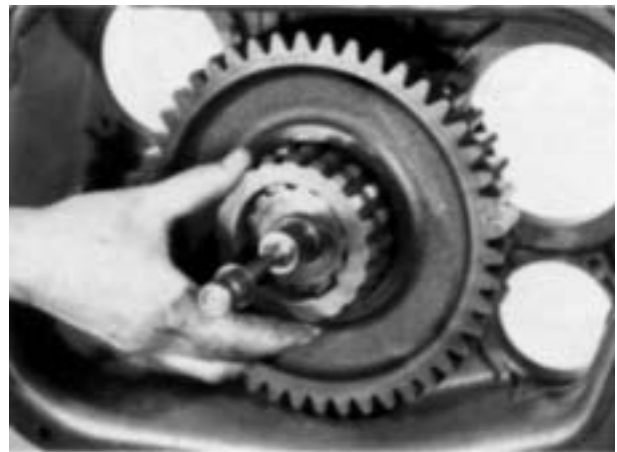

16. Install the sliding clutch gear on the front of the shaft, internal clutching teeth to the rear.

## Auxiliary Sections - continued

### V. RTO-1258LL Auxiliary Section Reassembly

#### B. INSTALLATION OF THE RANGE MAINSHAFT ASSEMBLY

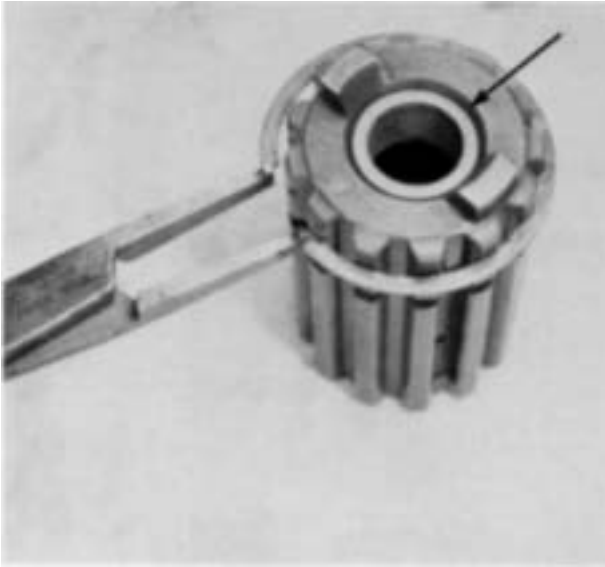

1. If previously removed, install the snap ring in the groove on mainshaft. Install the bushing in the shaft by driving or pressing until the top of the bushing is flush with the bottom of the chamfer cut in the mainshaft bone, (arrow).

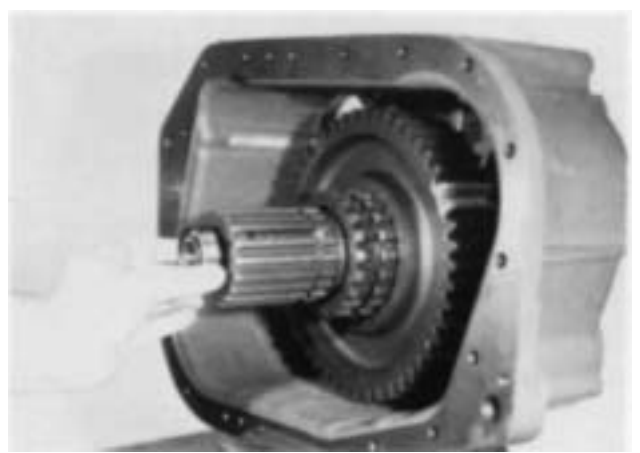

3. Install the bearing in the mainshaft and on the quill. A 3/4" socket can be used to install the bearing keeping the socket centered on the inner race and tapping lightly with a soft bar.

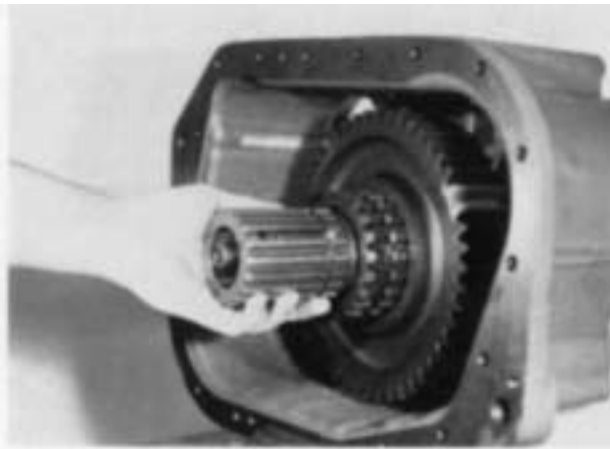

2. Install the mainshaft on the quill of the output shaft, seating the bushing on teh rear surface of the quill.

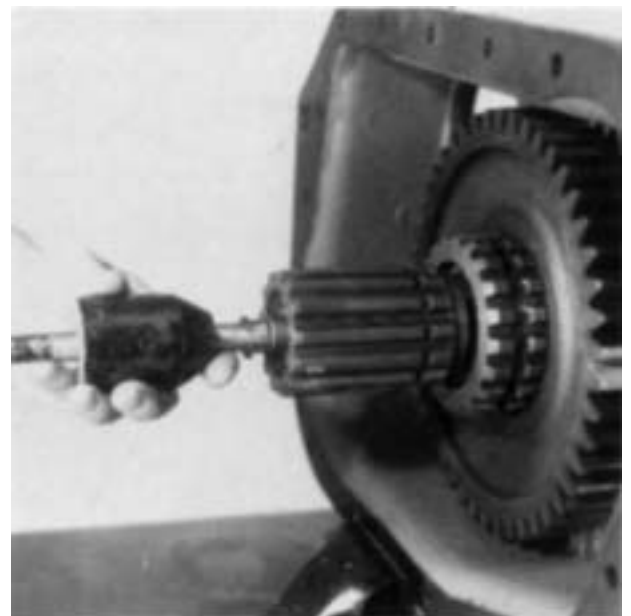

4. Install the snap ring on the front of the quill. Use of the proper snap ring driver is recommendcd. (See tool reference section ).

## C. REASSEMBLY AND INSTALLATION OF THE DEEP REDUCTION SHIFT CYLINDER

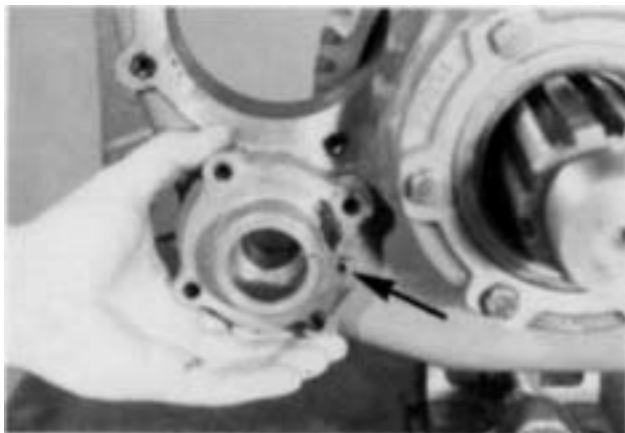
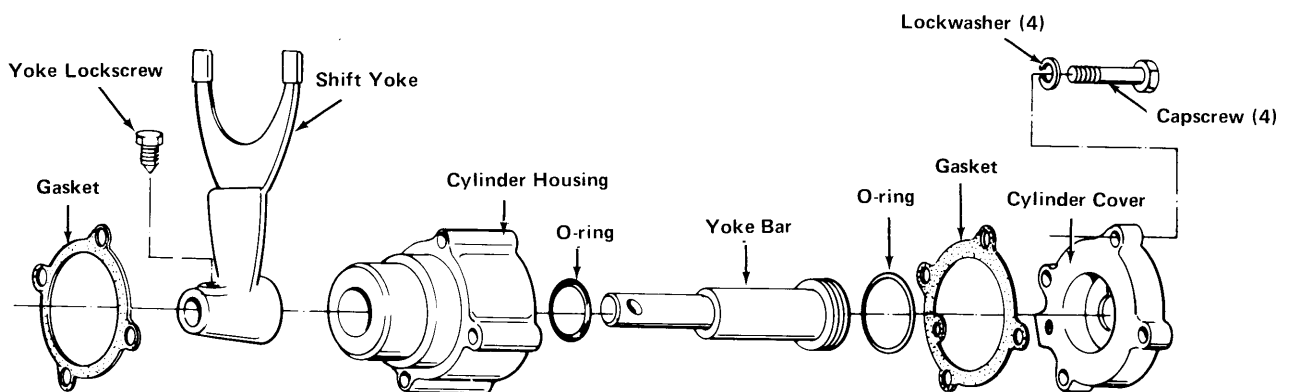

1. Install the O-ring in the bore of the shift cylinder and install the cylinder in the auxiliary housing with the air channel to the right.



2. Install the yoke in the sliding clutch yoke slot with the lockscrew hole facing up.



3. Install the O-ring in the yoke bar groove and push the yoke bar forward and through the cylinder housing and the shift yoke. Install the yoke lockscrew; tighten and wire securely.



4. Install the cylinder cover, aligning the air channel with the channel in the cylinder housing.



## Auxiliary Sections - continued

### V. RTO-1258LL Auxiliary Section Reassembly D. INSTALLATION OF THE LOW SPEED GEAR

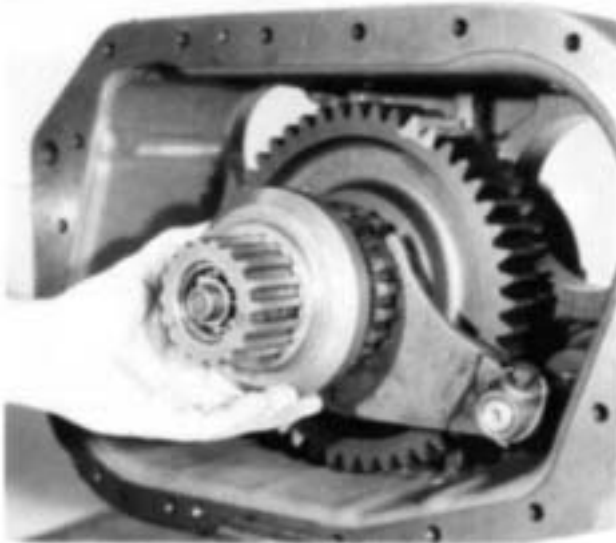

1. Install the coupler on the shaft, large diameter to the rear.

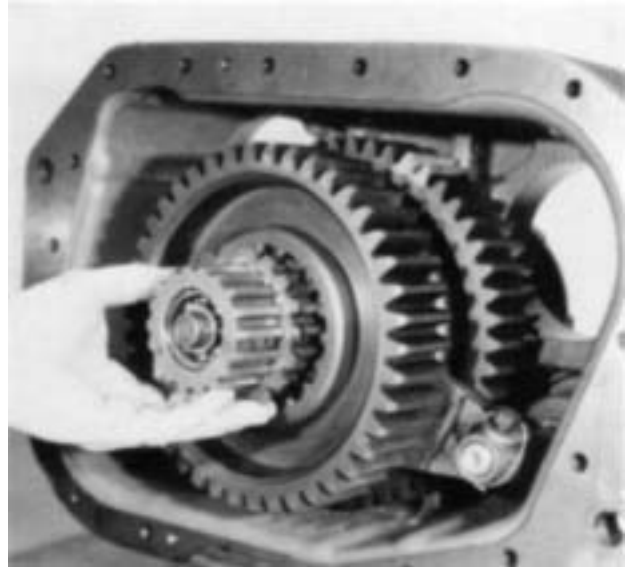

3. Install the splined washer on the shaft and in the hub of the gear. Turn the washer to lock the gear on the shaft. Washers with varying thicknesses are available. Use the washer which provides the tightest fit.

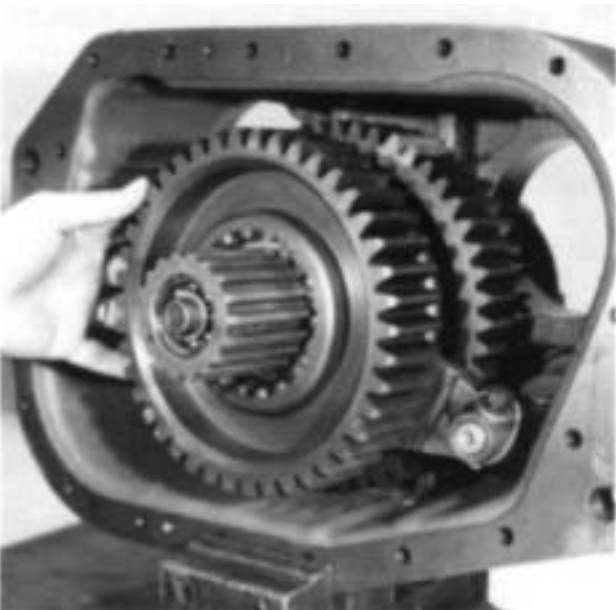

2. Install the low speed gear on the shaft and against the coupler, dished side to the front.

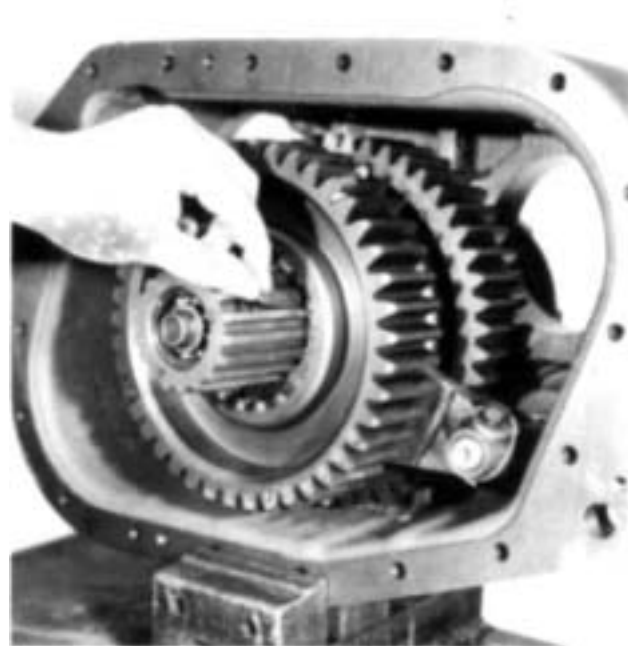

4. Install the key in the keyway, inserting the thick end between the splines of the washer.

## E. REASSEMBLY AND INSTALLATION OF THE SYNCHRONIZER ASSEMBLY



1. Place the low speed ring on a workbench with the pins facing up. Install the sliding clutch on the low speed ring with the dished side up.



3. Apply pressure to the direct ring and twist to compress the springs and seat the ring fully on the pins. It maybe helpful to place the assembly on a rag during this step to prevent the ring on the bottom from turning.



2. Coat the three synchronizer springs with grease to hold them in place and install in the three bores in the direct ring. Place the ring over the pins of the low speed ring with the springs against the blocker pins.

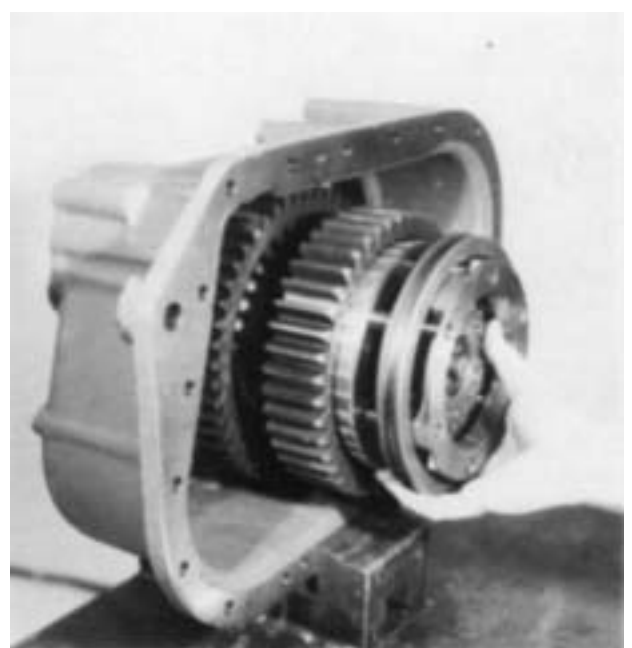

4. Install the synchronizer on the range mainshaft with the low speed ring seated fully into the low speed gear bore.

## Auxiliary Sections - continued

### V. RTO-1258LL Auxiliary Section Reassembly

#### F. TIMING AND INSTALLATION OF THE AUXILIARY COUNTERSHAFTS



1. Mark the tooth which is stamped with an "o" on each of the three sets of gears on the auxiliary countershafts.



2. Place one of the countershafts into position in the case, meshing the marked teeth on the shaft between one of the sets of marked teeth on each of the gears. Hold the countershaft in position and use a soft bar to tap the rear bearing onto the shaft and into the case bore. Use a bearing driver to complete installation of the bearing. Check the synchronizer during bearing installation to make sure that the springs do no pop out. Repeat the procedure to install the remaining countershaft.

**IMPORTANT:** Make sure that the bearing inner race is installed on the front of each countershaft.

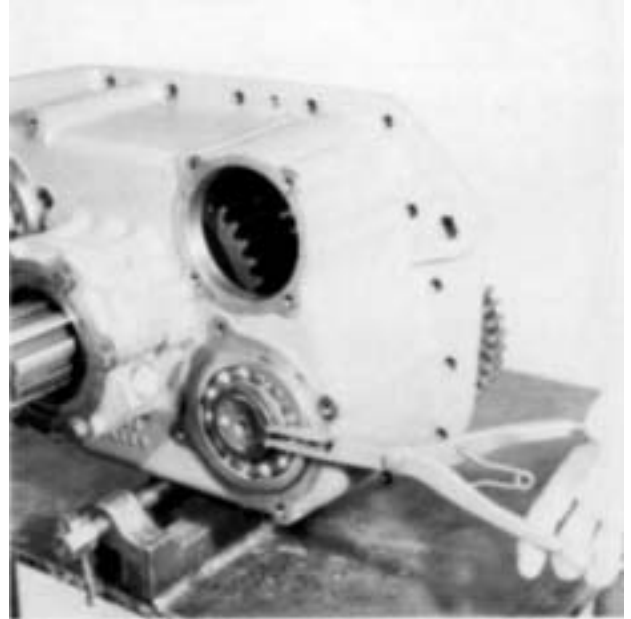

3. Install the snap ring in the groove on the rear of each countershaft.



4. Install the two rear bearing covers.

## G. REASSEMBLY AND INSTALLATION OF THE RANGE SHIFT CYLINDER



1. If previously removed, install the O-ring in the bore of the shift cylinder and apply a thin coat of silicone lubricant. Install the cylinder and gasket in the auxiliary housing bore with the air fitting to the top.

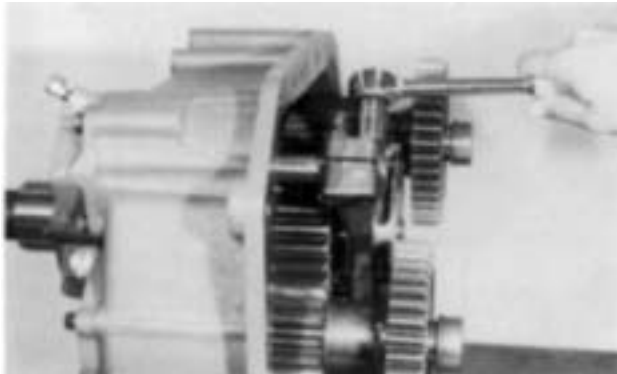

2. Hold the shift yoke in position on the synchronizer clutch gear with the long hub of the yoke to the rear and insert the yoke bar, threaded end first, through the yoke hub and shift cylinder, aligning the slots in the bar with the lock screw bores in the yoke hub. Install the yoke lock screws; tighten and wire securely.



3. Install the O-rings in the OD and ID of the piston.



4. Install the piston on the yoke bar, flat face out. Apply a thin coat of silicone lubricant to the O-rings.

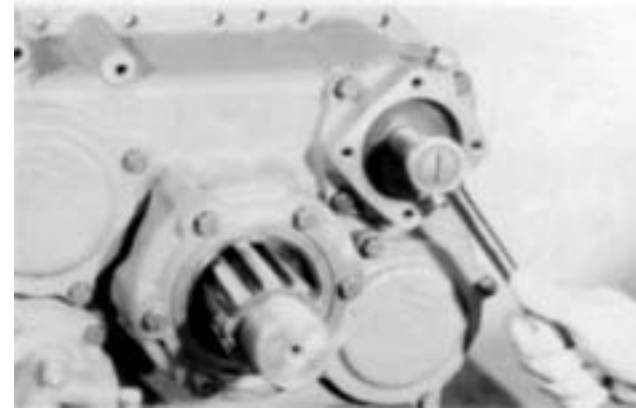

5. Install the nut on the end of the yoke bar; tighten securely with 70-85 lbs. ft. of torque.

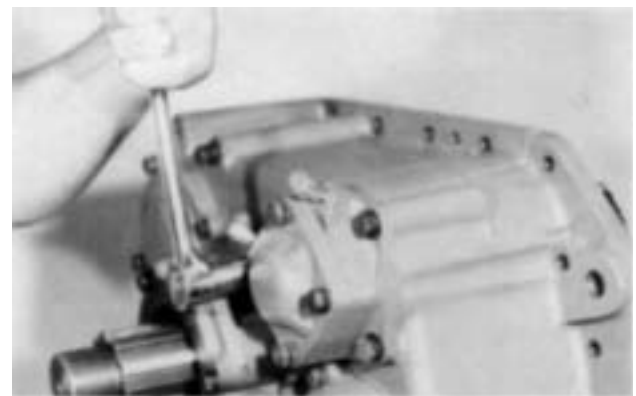

6. Install the cover and gasket on the cylinder with the air fitting to the top left.

**CAUTION:** If a gasket is used which requires shellac or permatex, USE ONLY A VERY SMALL AMOUNT to prevent clogging of cylinder air ports or damage to O-rings.

# Auxiliary Sections - continued

## VI. RT-12513 Auxiliary Section Disassembly

### A. REMOVAL AND DISASSEMBLY OF THE RANGE SHIFT CYLINDER

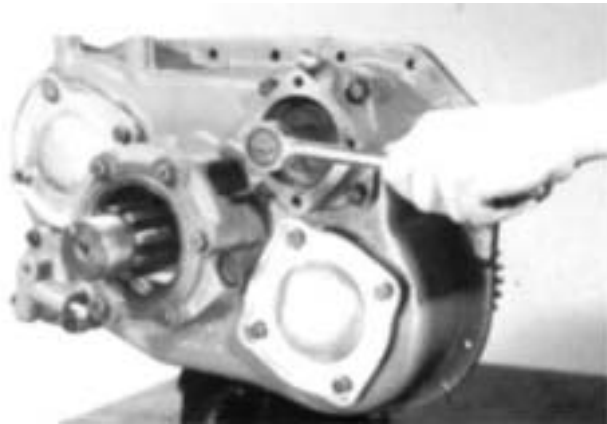
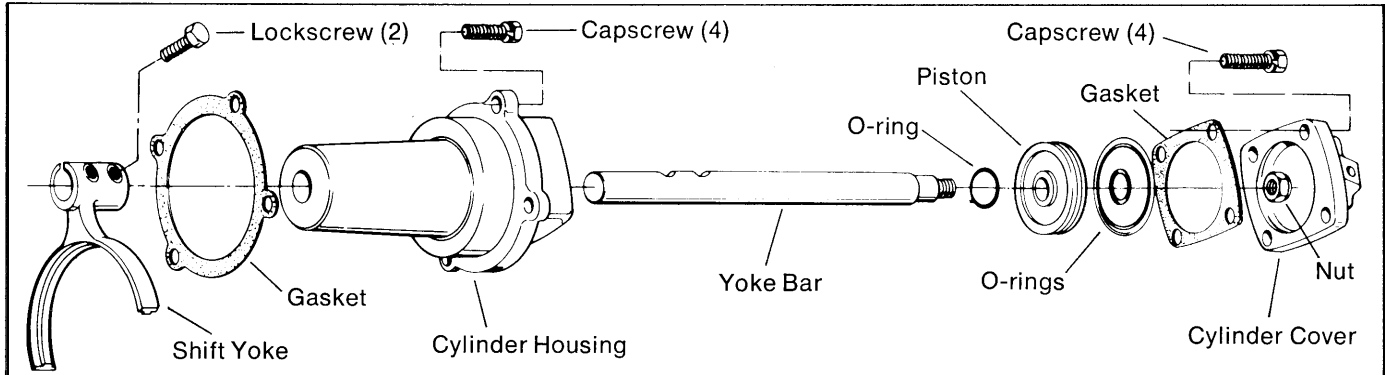

1. Remove the range shift cylinder cover and remove the nut from the end of the yoke bar.



3. Remove the piston from the yoke bar and if necessary, remove the O-rings from the OD and ID of the piston. Push the yoke bar forward and from the housing.

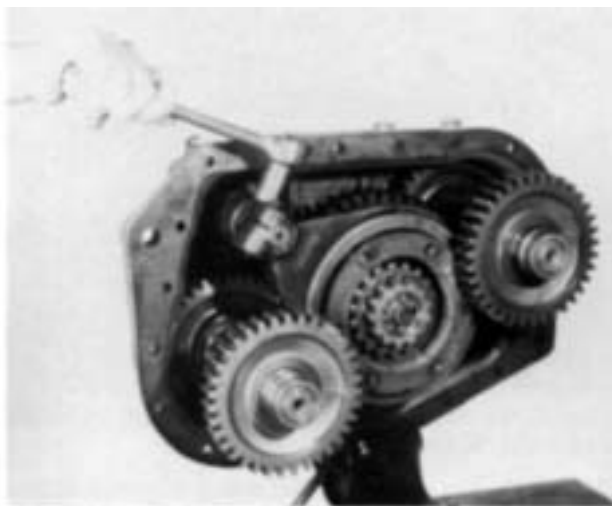

2. Cut the lockwire and turn out the two yoke lock-screws.

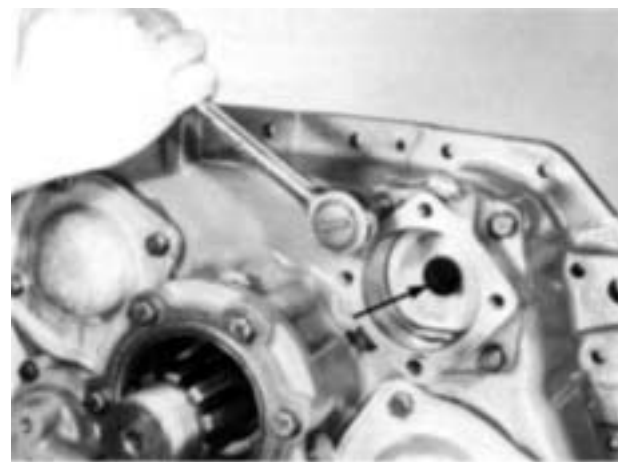

4. Remove the cylinder housing from the auxiliary housing. If necessary, remove the O-ring from the housing bore, (arrow). Remove the shift yoke from the synchronizer.

## B. REMOVAL OF THE AUXILIARY COUNTERSHAFT BEARINGS



1. Remove the two countershaft rear bearing covers and remove the snap ring from the rear of each countershaft.



3. Move the countershaft back to the rear to expose the bearing snap rings.

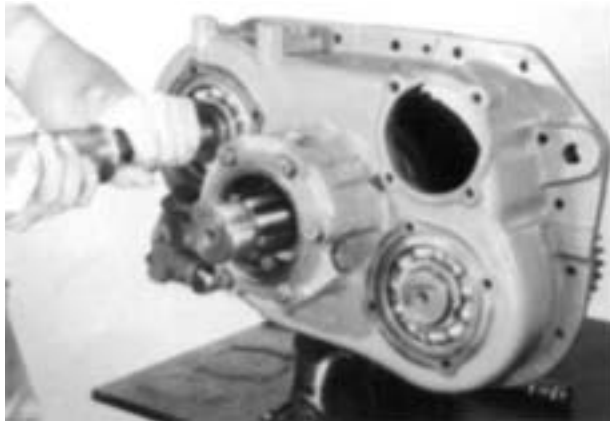

2. Use a soft bar and mallet to drive the countershafts forward approximately 1/2" to partially unseat the bearings.

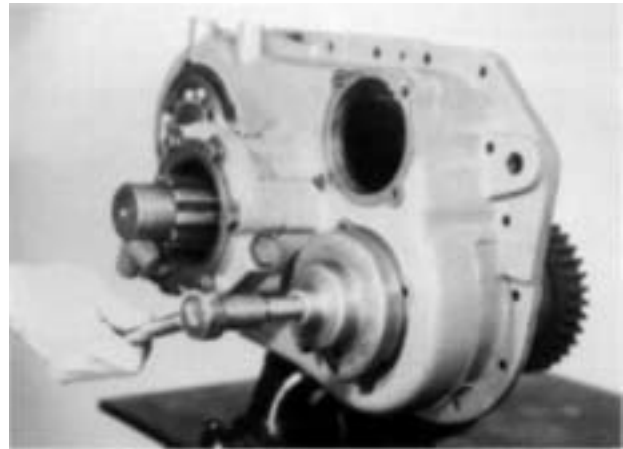

4. Use a puller to remove the countershaft rear bearings.

## C. REMOVAL AND DISASSEMBLY OF THE SYNCHRONIZER ASSEMBLY

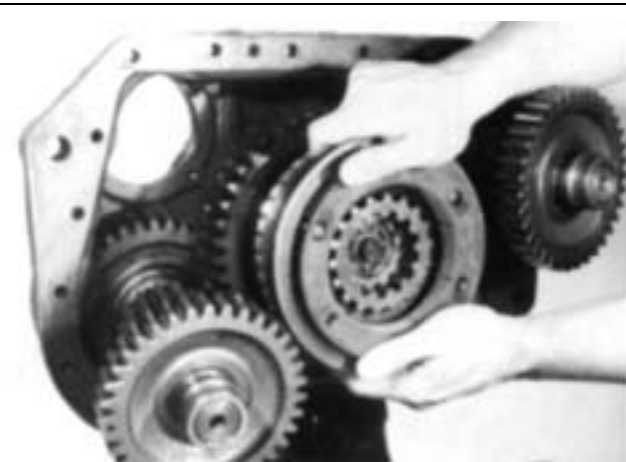

1. Spread the countershaft and remove the synchronizer.



2. Pull the direct ring from the pins of the low speed ring. Cover the assembly with a cloth during this step to prevent loss of the three springs. Remove the sliding clutch gear from the low speed ring.

## Auxiliary Sections - continued

### VI. RT-12513 Auxiliary Section Disassembly D. REMOVAL OF THE LOW RANGE GEAR

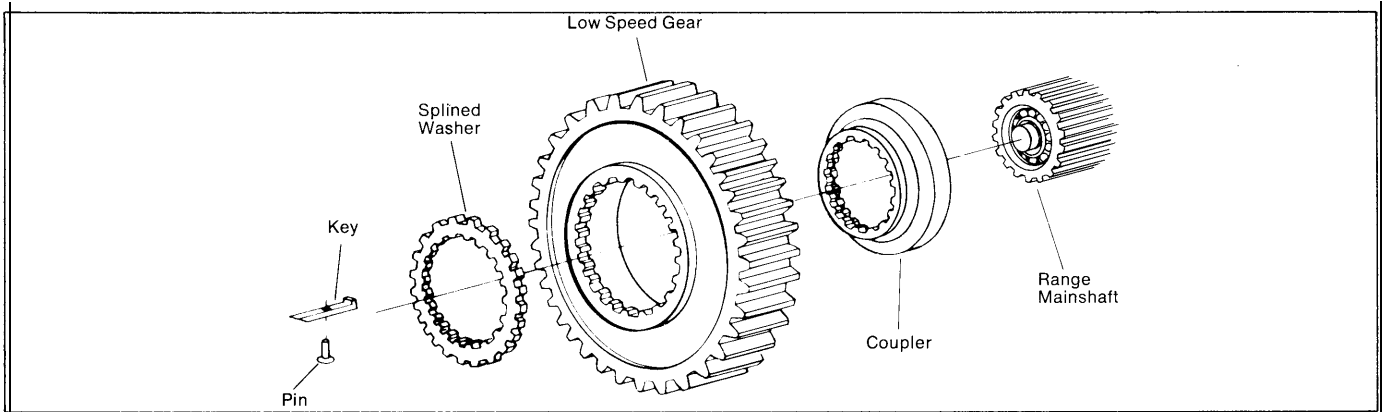

1. Remove the key from the keyway between the splines of the range mainshaft.



3. Remove the low range gear and washer from the shaft.



2. Turn the splines of the low speed gear washer to align with the splints of the shaft.



4. Remove the coupler from the shaft and remove the right countershaft from the housing. The left countershaft cannot be removed at this time.

## E. REMOVAL AND DISASSEMBLY OF THE SPLITTER GEAR SHIFT CYLINDER

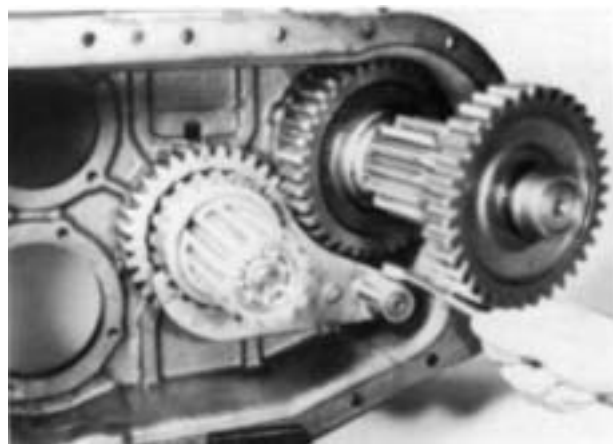
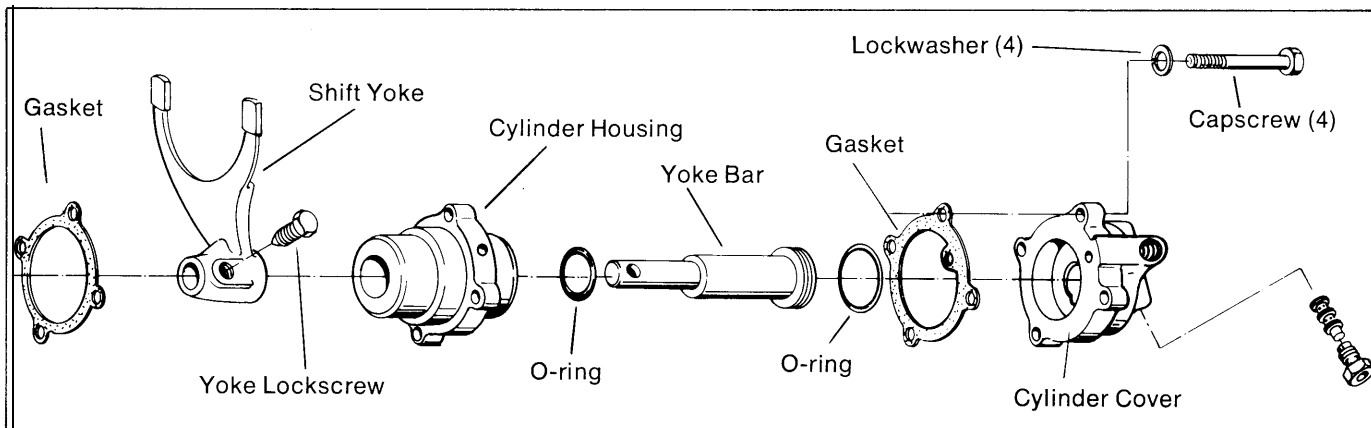

1. Cut the lockwire and remove the yoke lockscrew.



3. Pull the yoke bar from the cylinder housing; remove the O-ring if necessary.



2. Remove the cylinder cover. If necessary, turn out the plug on the cover and remove the insert valve.

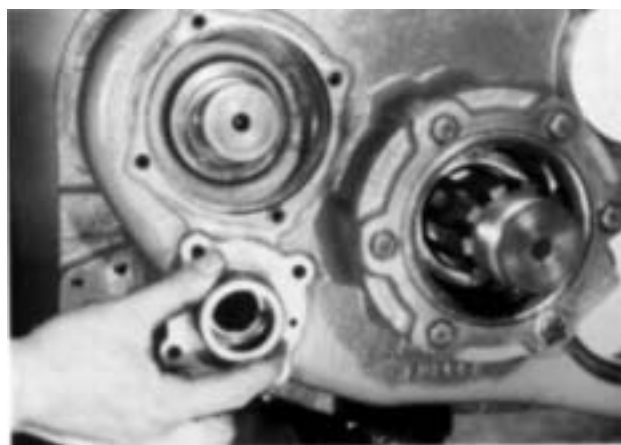

4. Remove the shift yoke and remove the shift cylinder from the auxiliary housing. If necessary, remove the O-ring from the bore in the shift cylinder. The left countershaft may now be removed from the auxiliary housing.



## Auxiliary Sections - continued

### VI. RT-12513 Auxiliary Section Disassembly

#### F. REMOVAL AND DISASSEMBLY OF THE RANGE MAINSHAFT ASSEMBLY

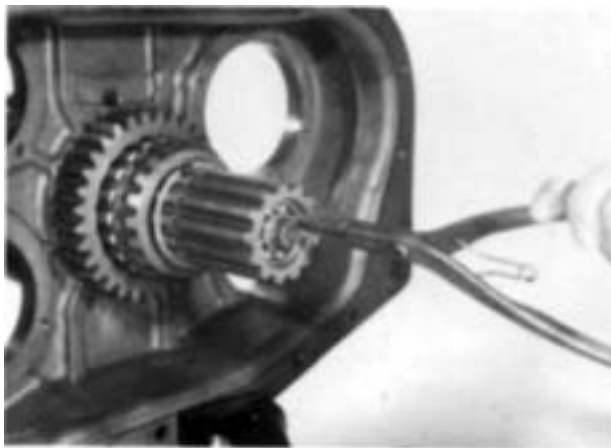
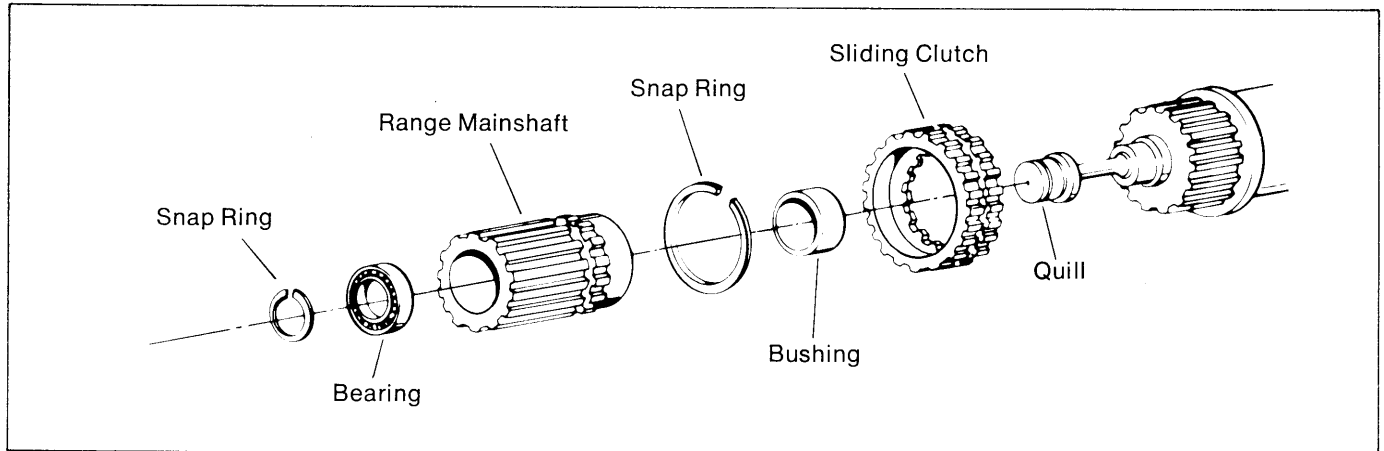

1. Remove the snap ring from the front of the range mainshaft.



3. If necessary, remove the bearing from the mainshaft by tapping lightly from the inside with the range shift yoke bar or a similar size rod.



2. Use a puller on the sliding clutch to remove the mainshaft and clutch from the output shaft quill.

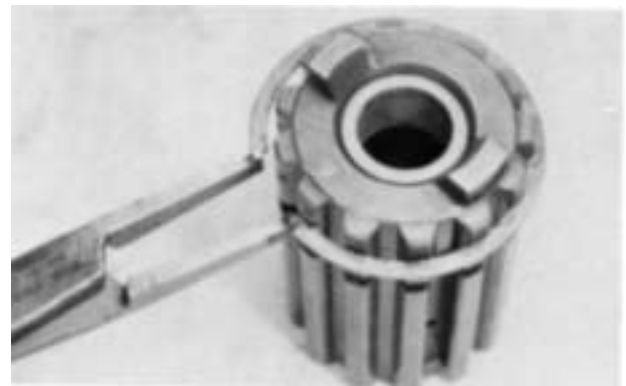

4. If necessary, remove the snap ring and bushing from the mainshaft. A 15/16" socket can be used by installing the back face of the socket from the inside of the shaft against the bushing and using a steel rod to drive against the socket.

## G. REMOVAL AND DISASSEMBLY OF THE OUTPUT SHAFT

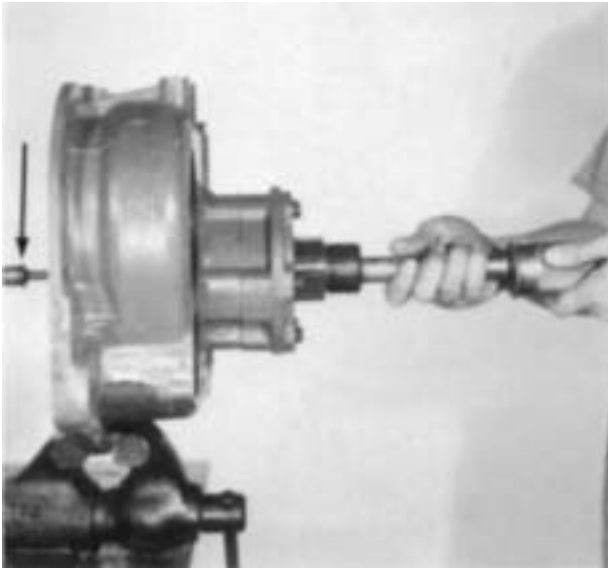

1. Use a soft bar and mallet to drive the output shaft forward and from the rear housing. Do not allow the output shaft to fall on the quill, (arrow).

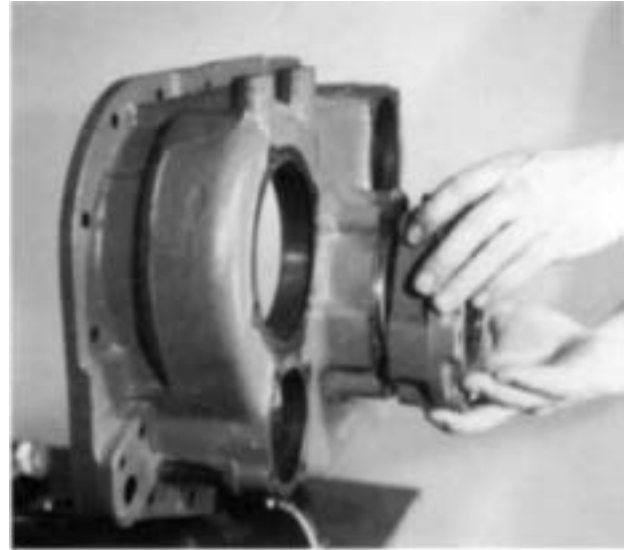

3. Turn out the capscrews and remove the rear bearing cover. If necessary, remove the oil seal from the cover with a hammer and punch. Removal procedures will damage the seal and removal should not be attempted unless replacement of the seal is planned.



2. Use the splitter gear as a base to press the output shaft through the gear, washer and bearing. If necessary, remove the snap ring from the bore of the splitter gear.

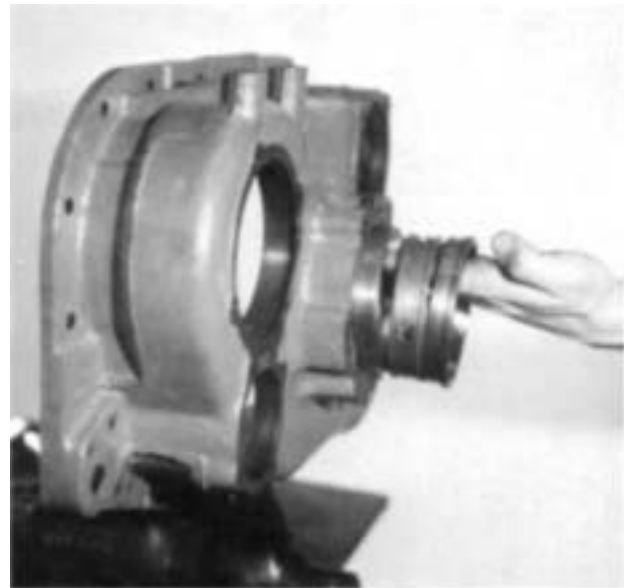

4. Remove the rear bearing cone and using a small hammer and punch, tap lightly to move the two bearing cups and outer spacer to the rear and from the housing bore. Use caution to avoid marking the machined surface of the bore.

## Auxiliary Sections - continued

### VII. RT-12513 Auxiliary Section Reassembly

#### A. REASSEMBLY AND INSTALLATION OF THE OUTPUT SHAFT ASSEMBLY

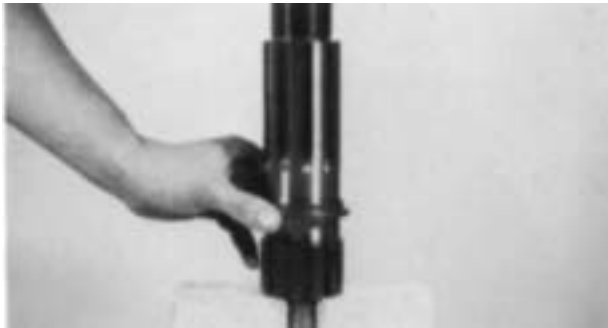

1. Place the output shaft on blocking to prevent damage to the quill and install the stepped spacer on the shaft, small diameter up.

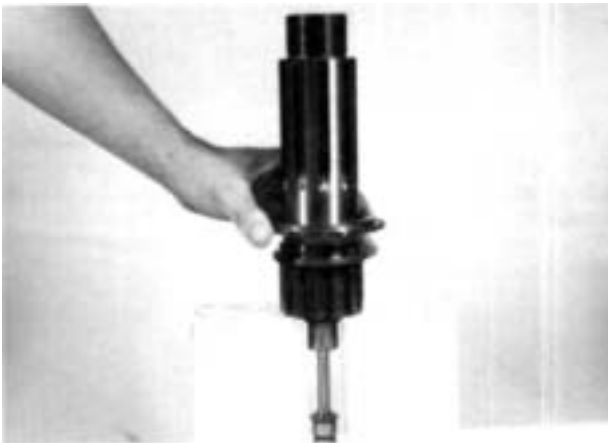

2. Install the splined washer on the shaft, shoulder up.

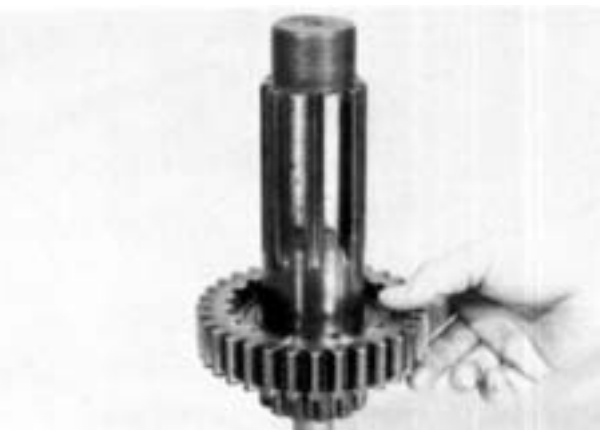

3. If previously removed, install the snap ring in the groove in the splitter gear. Install the splitter gear on the shaft and over the splined washer, snap ring up.

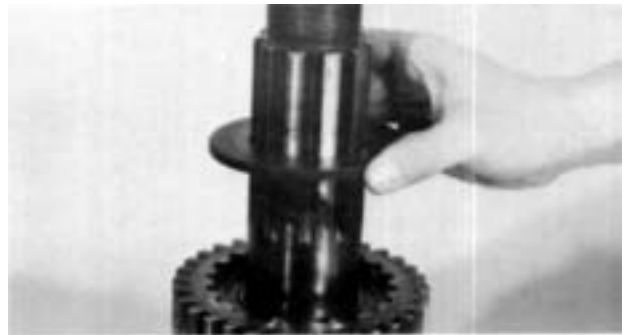

4. Install the rear washer on the shaft, flat side up.



5. Heat the front bearing cone and install on the shaft with the taper up. (Do not heat the bearing over 275°F).

**NOTE:**

The two bearing cones and cups are a matched set. Make sure that the proper cone is used with the proper cup.



6. Install the bearing inner spacer on the shaft.

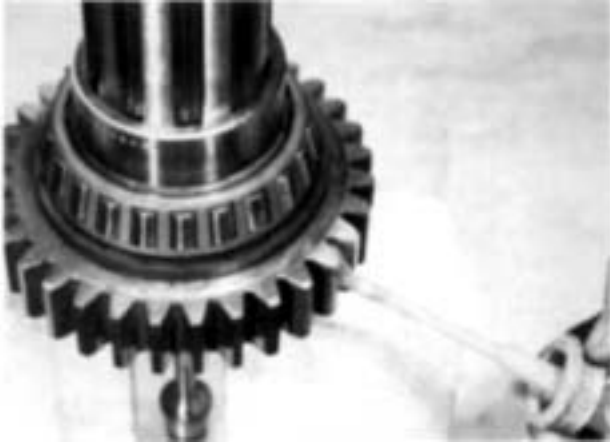

7. For timing purposes, mark any two adjacent teeth on the gear and then mark the two teeth directly opposite.



10. Heat the rear bearing cone and install on the shaft and in the cup. make sure that the lip of the cup is fully seated against the housing.



8. Start the front cup of the bearing into the auxiliary bore with the wide edge up. Stack the outer spacer and rear cup on the front cup and use a driver to seat all three evenly in the bore. Tap lightly to avoid driving the front cup out the bottom of the bore.



11. If previously removed, install the oil seal in the bearing housing with the surface with the seam to the inside.



9. Place the housing over the output shaft, seating the bearing in the cup.



12. Install the bearing housing and gasket on the auxiliary housing; use a brass washer on the cap screw which passes through the speedometer bore.

## Auxiliary Sections - continued

### VII. RT-12513 Auxiliary Section Reassembly

#### B. REASSEMBLY AND INSTALLING THE RANGE MAINSHAFT ASSEMBLY

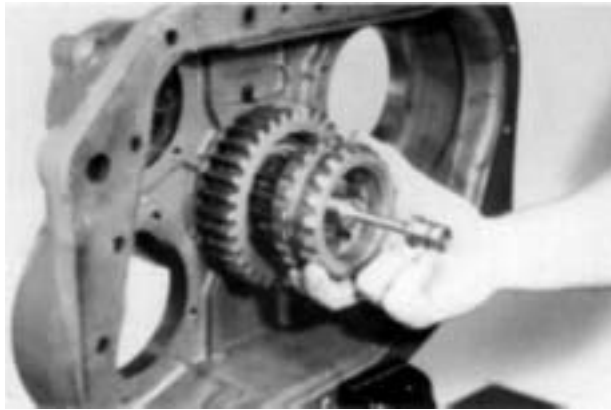

1. Install the splitter gear sliding clutch on the output shaft, internal splines to the rear.

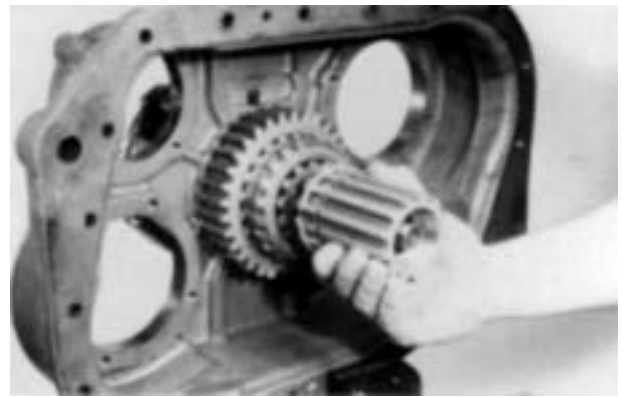

4. Place the mainshaft on the output shaft quill.

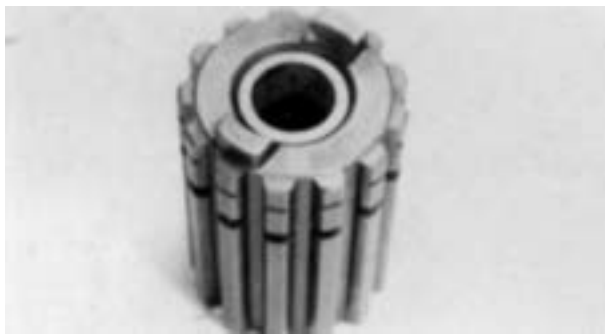

2. If previously removed, press the bushing in the mainshaft bore so that it is 1/16" below the face of the shaft.

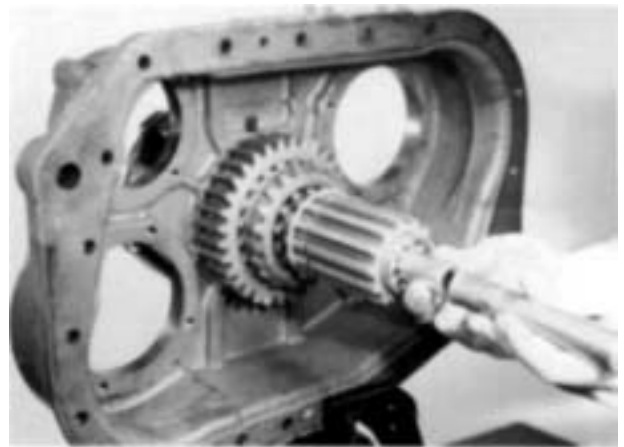

5. Install the front bearing in the mainshaft and on the quill. A 3/4" socket can be used as a bearing driver.

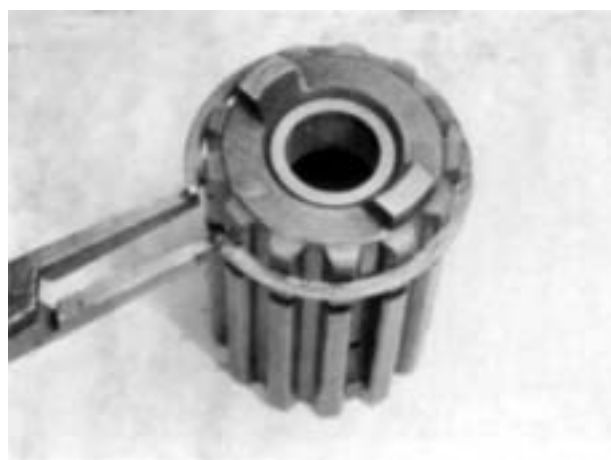

3. If previously removed, install the snap ring in the groove on the mainshaft.

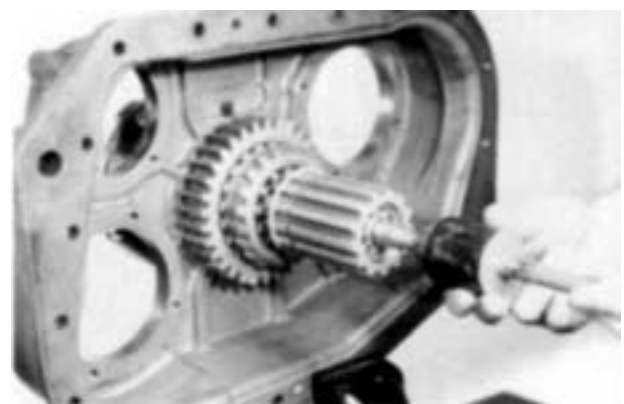

6. Use a snap ring driver to install the snap ring on the quill.

## C. INSTALLATION OF THE SPLITTER GEAR SHIFT CYLINDER

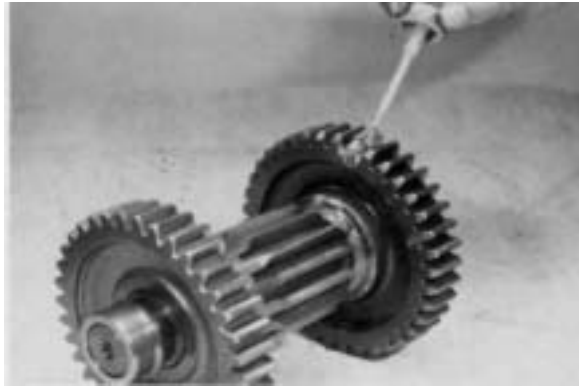

1. Mark the tooth which is stamped with an "O" on the splitter gear of each auxiliary countershaft. This gear is located on the end of the shaft which has the snap ring groove.



2. If the auxiliary countershaft front bearings are to be replaced, use a puller to remove the inner race from each shaft. Heat and install the inner races from the new bearings with the shoulder towards the gear.



3. Place the left countershaft into position, meshing the marked tooth on the shaft between two of the marked teeth on the splitter gear.



4. Install the yoke in the sliding clutch gear slot with the hub to the front.



5. If previously removed, install the O-rings on the piston and in the bore of the cylinder and apply a thin coat of silicone lubricant. Install the cylinder housing and gasket in the auxiliary housing with the air channel to the right, (arrow).



6. Push the yoke bar through the housing and yoke hub, aligning the lockscrew bore with the indentation in the yoke bar.

## Auxiliary Sections - continued

### VII. RT-12513 Auxiliary Section Reassembly

#### C. INSTALLATION OF THE SPLITTER GEAR SHIFT CYLINDER

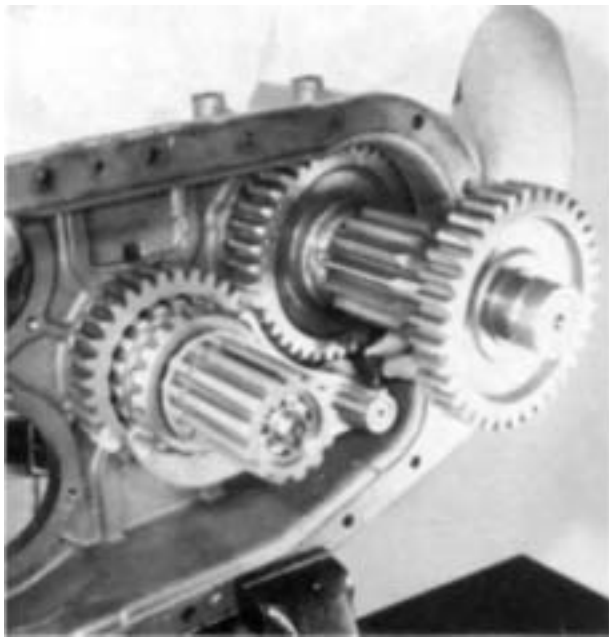

7. Install the yoke lockscrew; tighten and wire securely.



9. Install the exhaust screw in the cover to retain the insert valve.

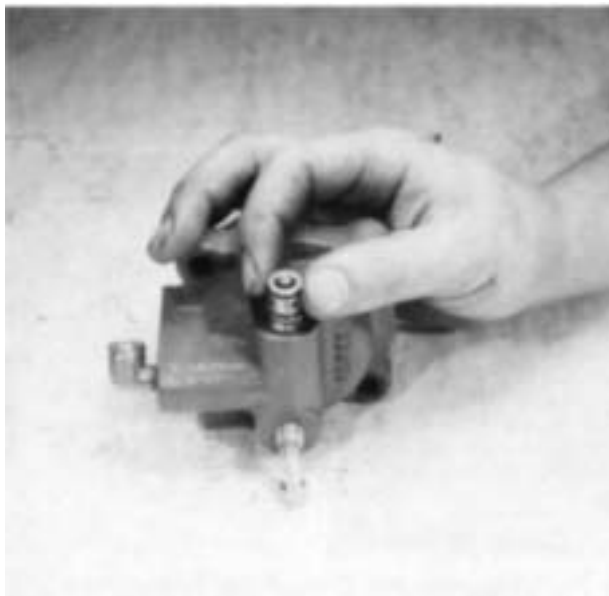

8. Install the insert valve in the cover as shown.

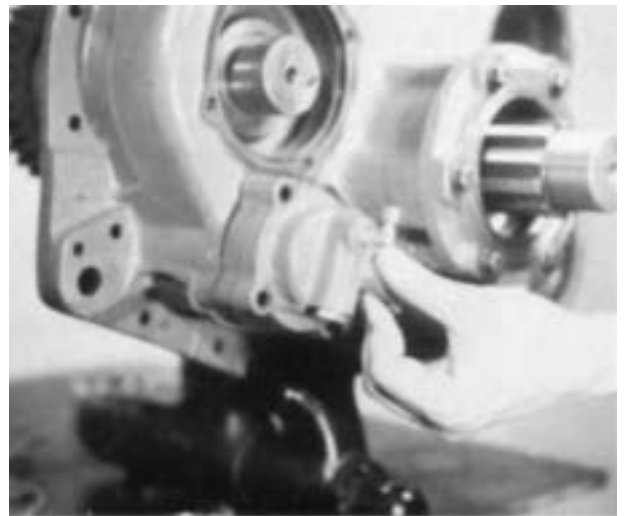

10. Install the splitter cylinder cover and gasket on the cylinder housing with the exhaust screw down. If gasket sealant is used, use only a small amount to avoid clogging the cylinder air ports.

## D. INSTALLATION OF THE LOW RANGE GEAR ASSEMBLY

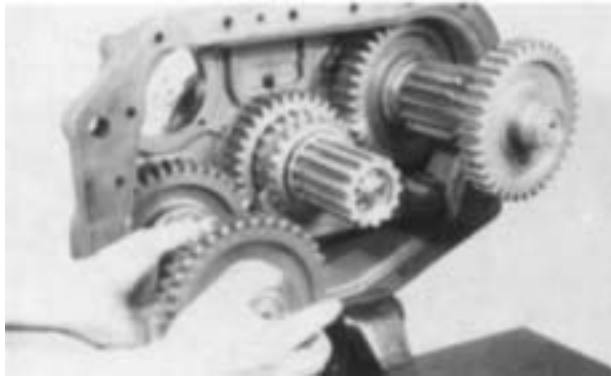

1. Place the right countershaft into position with the marked tooth between two of the marked teeth on the splitter gear. Make sure that the left countershaft is still in time.

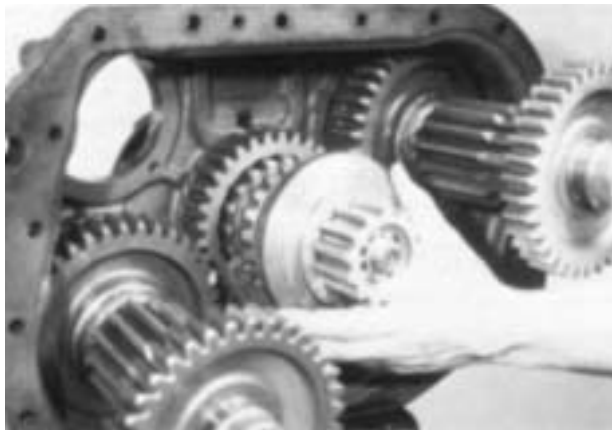

2. Install the coupler on the shaft and against the snap ring with the clutching teeth to the rear.



3. Install the low range gear on the shaft and against the coupler.

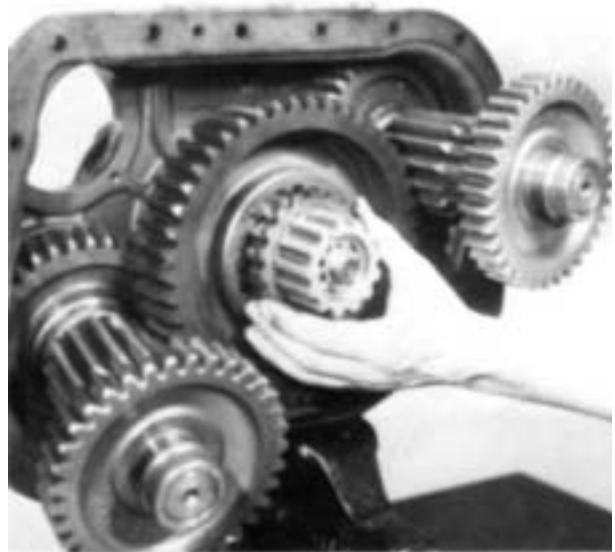

4. Install the washer on the shaft and in the hub of the gear. Turn the washer to lock the gear on the shaft.

**NOTE:**

Washers with varying thicknesses are available. Use the washer that provides the tightest fit.



5. Insert the key in the keyway on the mainshaft with the pin in the hole and the thick end between the splines of the washer.



## Auxiliary Sections - continued

### VII. RT-12513 Auxiliary Section Reassembly

#### E. REASSEMBLY AND INSTALLATION OF THE SYNCHRONIZER ASSEMBLY



1. Place the sliding clutch on the pins of the low speed synchronizer with the dished side of the clutch facing up.



2. Use grease to hold the three springs in the direct ring bores and place the direct ring on the pins of the low speed ring. Scat the direct ring fully on the low speed pins by pushing down and twisting to compress the springs. Install the synchronizer assembly on the range mainshaft, seating the low speed ring fully in the gear.

#### F. INSTALLATION OF THE AUXILIARY COUNTERSHAFT REAR BEARINGS



1. Check to make sure that the countershaft are still in time. Use a soft bar to start the bearings into the case bores and complete installation with a bearing driver and mall.

**NOTE:**

Check the synchronizer assembly often while installing the bearings to make sure that the direct ring does not move forward and off the low speed pins.

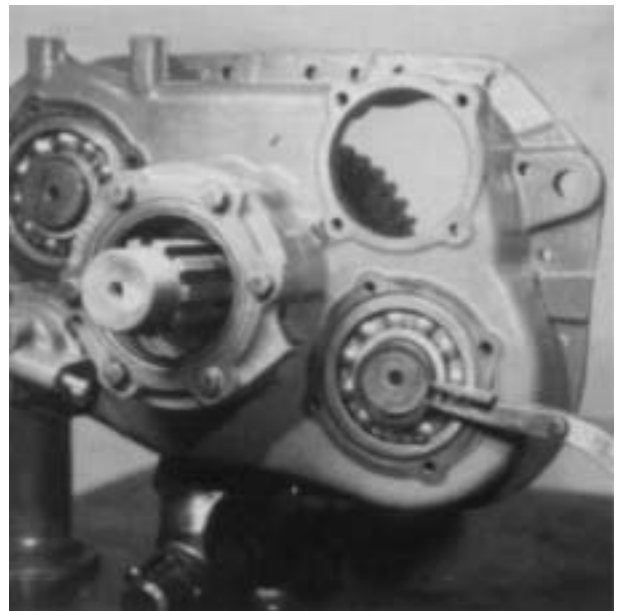

2. Install the snap ring in the groove at the rear of each countershaft. Install the two rear bearing covers and gaskets.

## G. INSTALLATION OF THE RANGE SHIFT CYLINDER ASSEMBLY

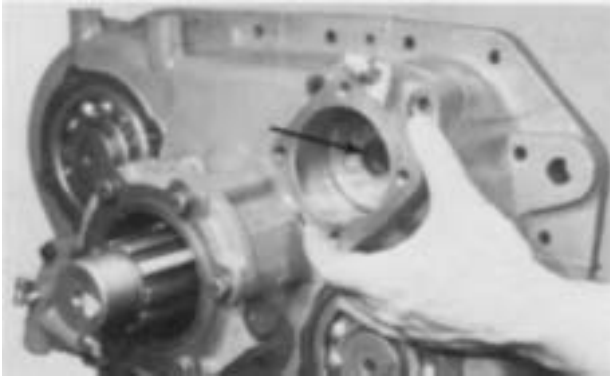

1. If previously removed, install the O-ring in the shift cylinder bore and apply a thin coat of silicone lubricant, (arrow). Install the shift cylinder and gasket in the auxiliary housing bore; secure with four capscrews with the air fitting to the top.

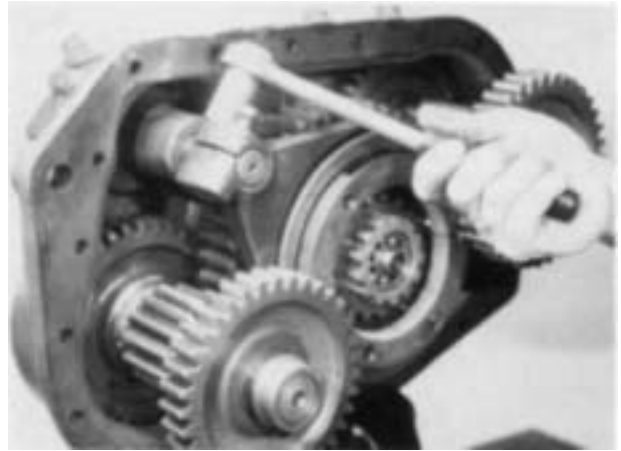

4. Install the two yoke lock screws; tighten and wire securely.

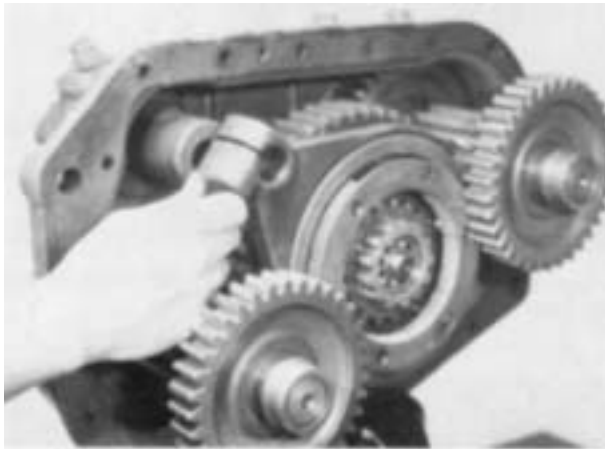

2. Place the shift yoke in the yoke slot on the synchronizer sliding clutch, long hub of the yoke to the rear.



5. If previously removed, install the O-rings in the OD and ID of the piston and apply a thin coat of silicone lubricant. Install the piston on the yoke bar and in the cylinder bore; secure with the nut.



3. Install the yoke bar, inserting the threaded end through the yoke hub and cylinder bore.



6. Install the range shift cylinder cover and gasket on the cylinder housing with the four capscrews. The air fitting should be to the top left.

## Front Section - All Models

### I. Front Section Disassembly - All Models

#### A. REMOVAL AND DISASSEMBLY OF THE AUXILIARY DRIVE GEAR ASSEMBLY

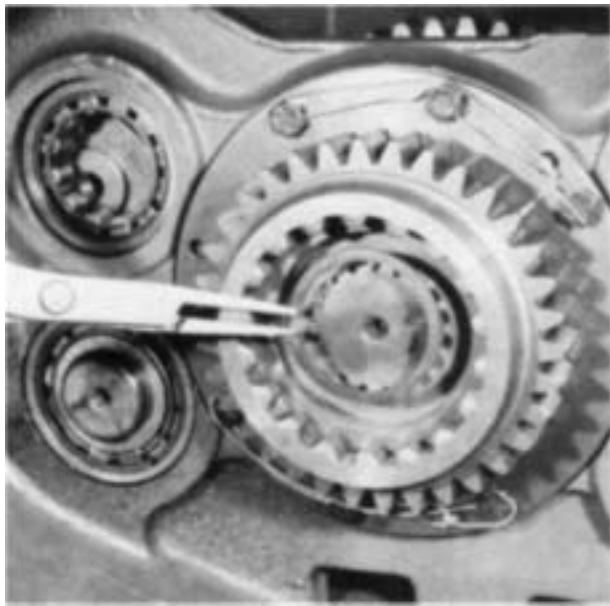

1. Remove the mainshaft rear snap ring. Use caution as the ring may jump off the pliers during removal.



3. Insert puller screws in the three tapped holes on the ring and tighten evenly to remove assembly.



2. Cut the lockwire and remove the six lockscrews from the bearing retainer ring.



4. Remove the snap ring from the shoulder of the drive gear; press the retainer ring and bearing from gear.

## B. REMOVAL AND DISASSEMBLY OF THE LEFT REVERSE IDLER GEAR ASSEMBLY

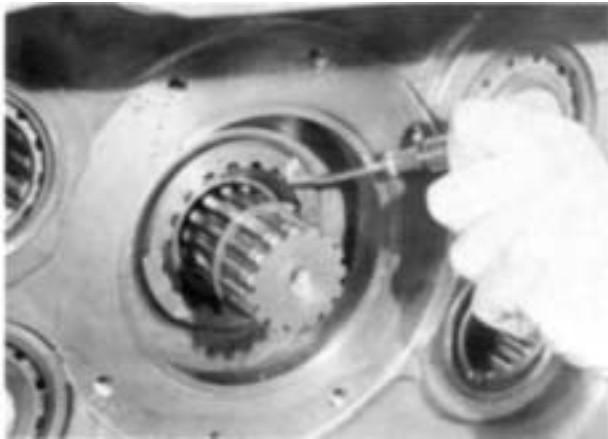

1. Remove the snap ring from the ID of the mainshaft reverse gear.



2. Move the gear as far forward as possible into engagement with the sliding clutch.



3. Remove the bearing from the idler bore. If the bearing is to be re-used, use an inside jaw impact puller. If the bearing is to be replaced, a crow's foot or pry bar may be used.



4. Remove the stop nut and washer.



5. Remove the plug and attach an impact puller to the idler shaft. Remove shaft from case.



6. Remove the gear and thrust washer from the case. If necessary, press the bearing outer race from the gear.



7. Remove the bearing inner race and cup from the shaft; these parts may in some cases remain in the idler bore.

## Front Section - All Models - continued

### I. Front Section Disassembly - All Models

#### C. REMOVAL OF THE COUNTERSHAFT BEARINGS



**NOTE:**

It is necessary to remove the bearings from only the right countershaft to remove the mainshaft.

1. Remove the snap ring from the rear of each countershaft.



2. Use a soft bar and punch from inside the case to drive the rear bearings to the rear and from the case bores.

**NOTE:**

Removal procedures will damage the bearings and removal should not be attempted unless replacement of the bearings is planned.

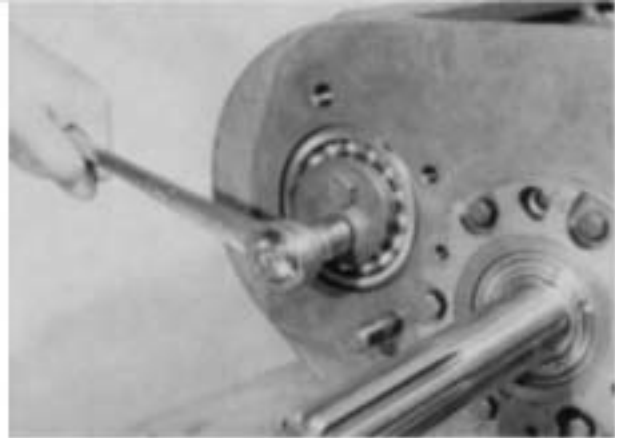

3. Cut the lockwires, turn out the lock screws and remove the two front bearing retainer plates.

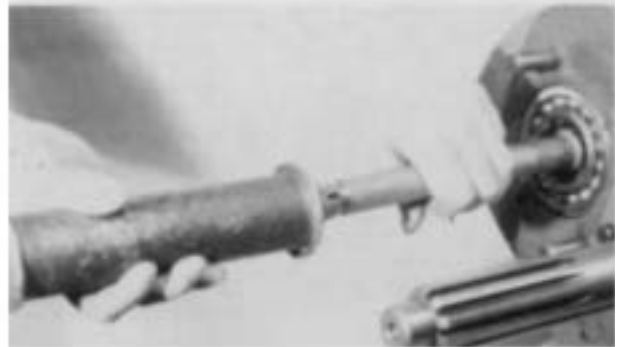

4. Move each countershaft to the rear approximately 1/2" using a soft bar and mallet.



5. Drive against the rear of each countershaft to move them as far forward as possible. This will expose the front bearing snap rings. Use a puller to remove the front bearings. Remove the spacer from the front of each countershaft.

## D. REMOVAL AND DISASSEMBLY OF THE MAINSHAFT ASSEMBLY

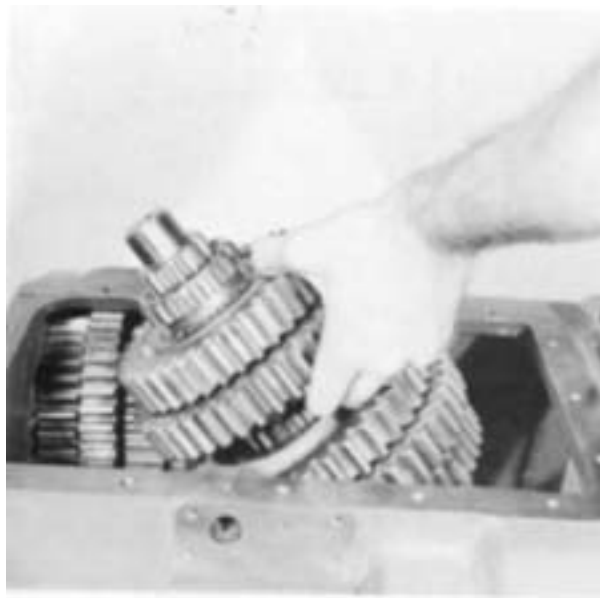

1. Block the right countershaft against the wall of the case. Hold the reverse gear tight against the first speed gear and move the assembly to the rear and out of the input shaft pocket. Tilt the front of the mainshaft up and lift from case. Use caution as the reverse gear is free and can fall off the shaft.

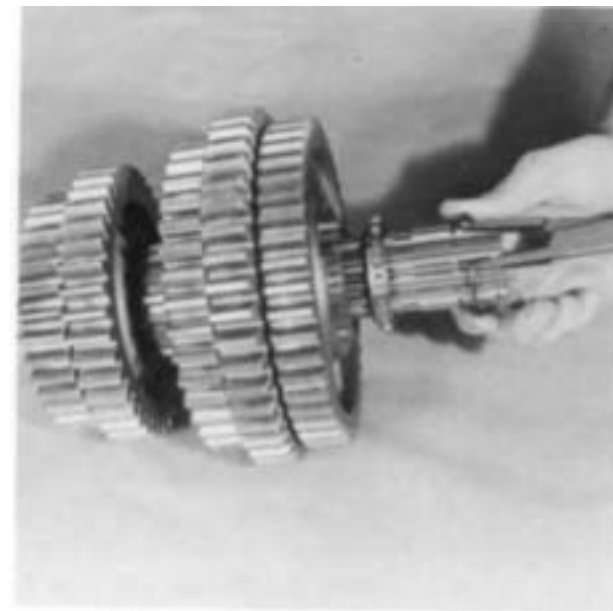

2. Remove the sliding clutch at the front of the shaft and remove the snap ring from the rear of the shaft.

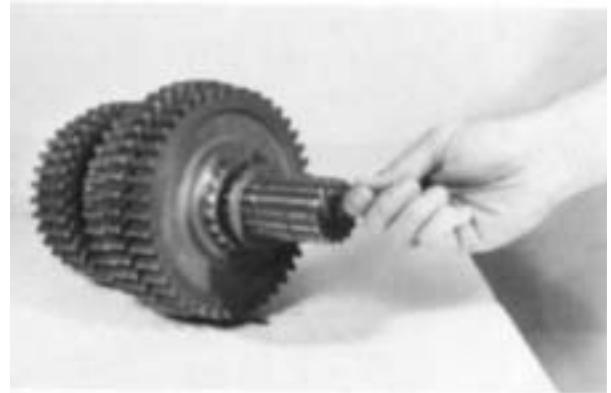

3. Pull the key from the mainshaft; this will unlock the parts

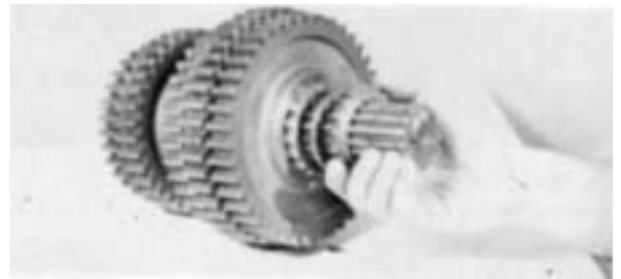

4. Remove the reverse gear spacer and washer.

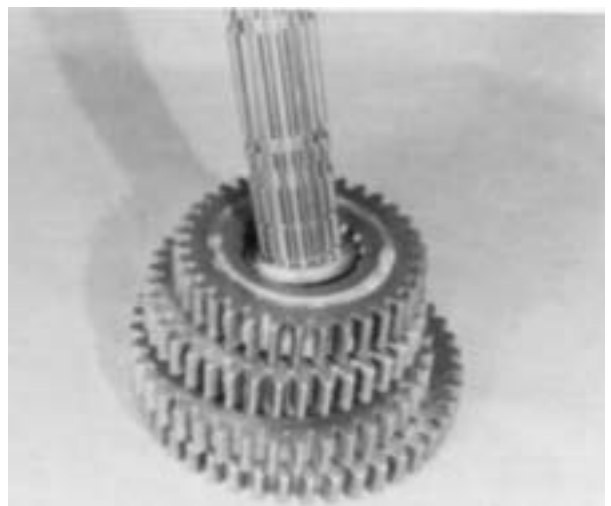

5. Tip the front of the shaft up and twist back and forth. The gearing will slide off the rear of the shaft in the proper order for reassembly. If necessary, remove the snap rings from the gears.

## Front Section - All Models - continued

### I. Front Section Disassembly - All Models

#### E. REMOVAL AND DISASSEMBLY OF THE DRIVE GEAR ASSEMBLY



1. Remove the front bearing cover.

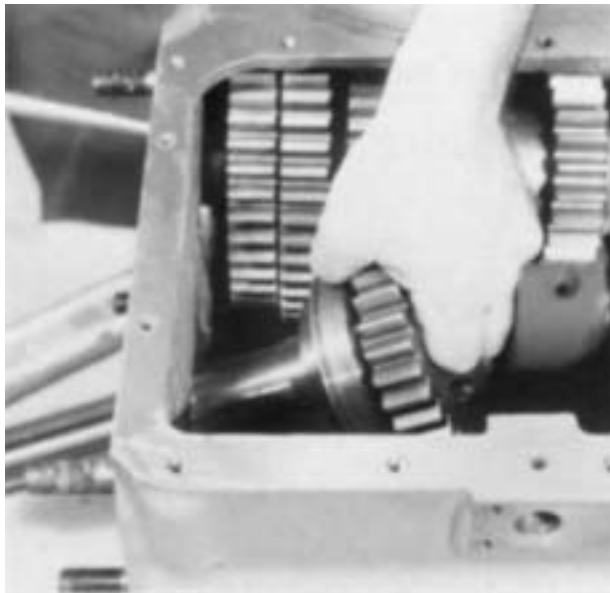

2. From inside the case, tap the drive gear forward so that the snap ring can be removed from the bearing and move the assembly to the inside of the case, working past the countershaft assemblies. Remove the drive gear assembly from the case.



3. Relieve the bearing nut where it is peened into the shaft and turn the bearing nut from the shaft; left hand thread.

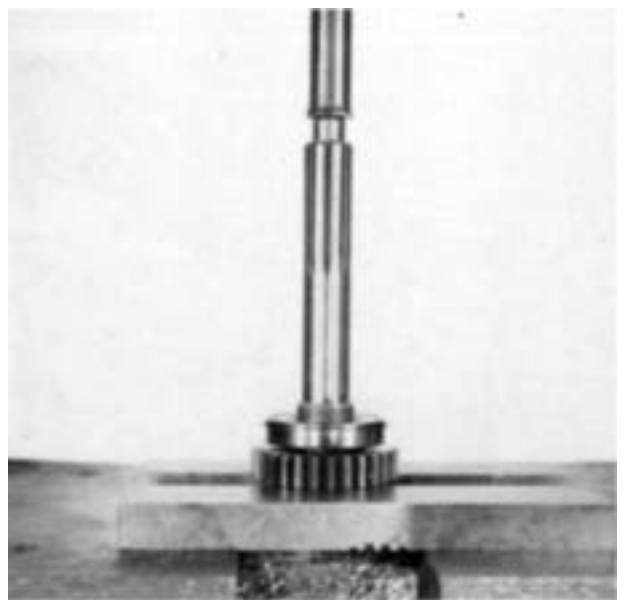

4. Press the shaft through the bearing and gear. If necessary, remove the snap ring from the ID of the drive gear. Check the bushing in the pocket of the shaft and replace if damaged or worn.

## F. REMOVAL AND DISASSEMBLY OF THE COUNTERSHAFT ASSEMBLIES

**NOTE:**

Except for the number of teeth on the PTO gears, the countershaft assemblies are identical.



1. Remove the right countershaft and left countershaft assemblies from the case by moving the front of each towards the center of the case and lifting out.



2. Press the top three gears from each shaft. (This will require a press with at least a 25 ton capacity; use metal shield as a safety precaution.)

**IMPORTANT:** Never use the PTO gear as a base for pressing as the large diameter of this gear makes it susceptible to breakage.

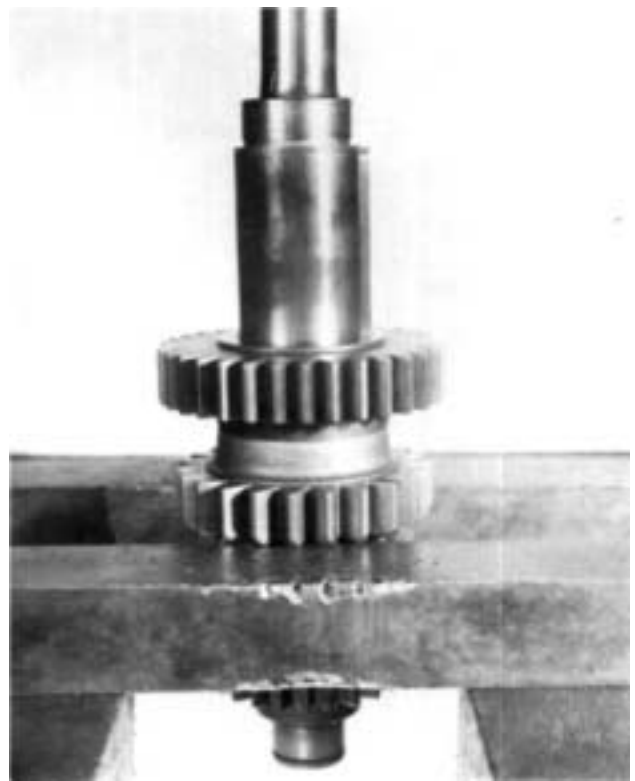

3. Press the remaining gears from the shaft. If necessary, remove the long key and woodruff key from the shaft.

## G. REMOVAL AND DISASSEMBLY OF THE RIGHT REVERSE IDLER GEAR ASSEMBLY

**NOTE:**

The right reverse idler gear assembly is identical to the left and is disassembled in the same manner.



## Front Section - All Models - continued

### II. Front Section Reassembly - All Models

#### A. REASSEMBLY AND INSTALLATION OF THE RIGHT REVERSE IDLER GEAR ASSEMBLY

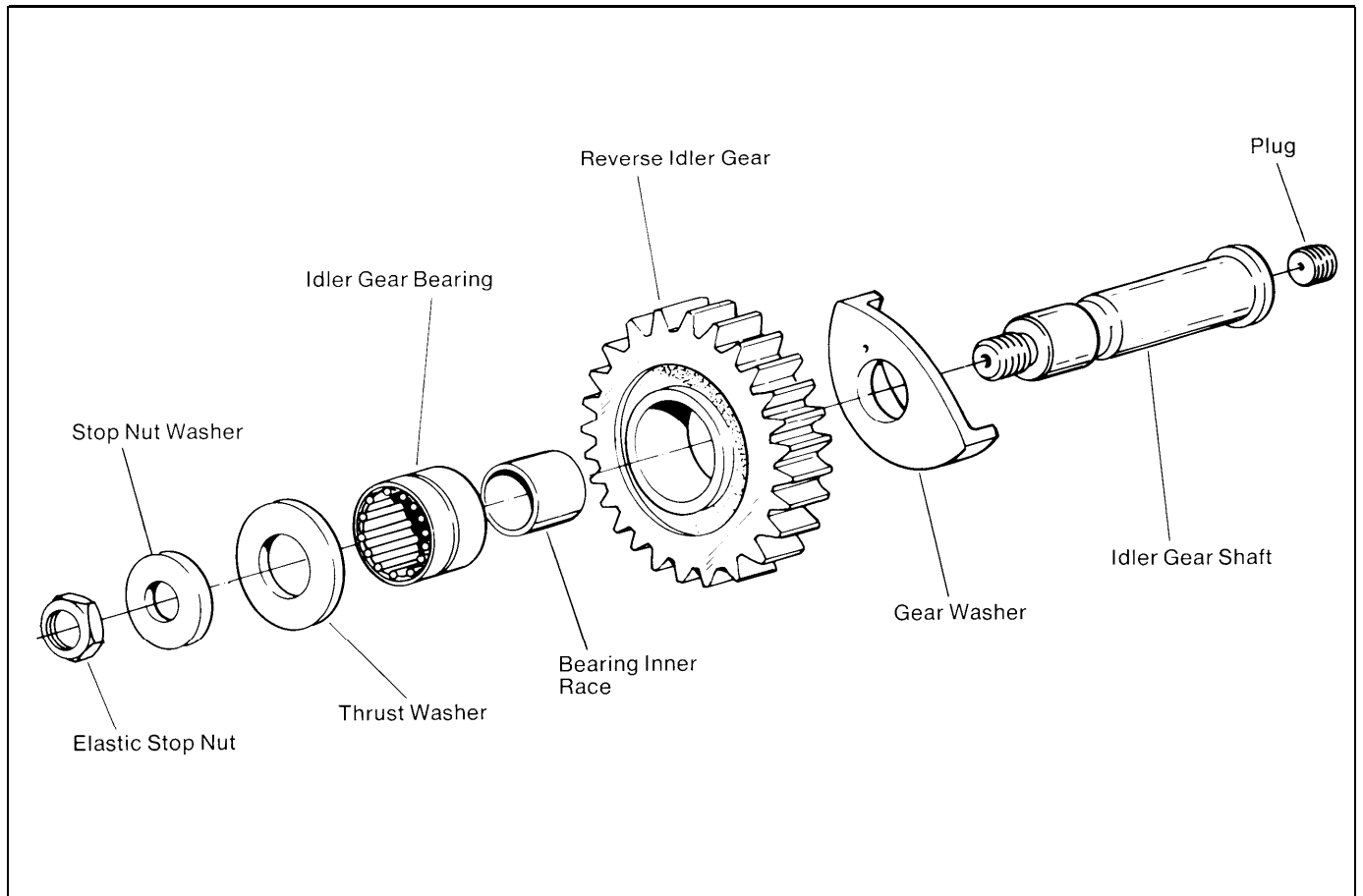

**NOTE:**

Before starting reassembly, make sure that the three magnetic discs are in place in the bottom of the case.



1. Install the plug in the end of the shaft and install the cup and bearing inner race on the shaft.



3. Install the gear and thrust washer on the shaft as the shaft is inserted into the bore. Make sure that the long hub of the gear (arrow), faces towards the front of the case.



2. Press the bearing in the bore of the gear.

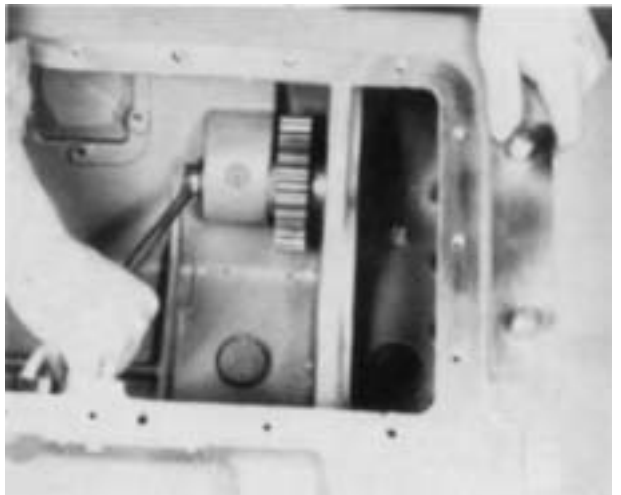

4. Install the elastic stop nut and washer on the shaft. Install the auxiliary countershaft front bearing outer race in the reverse idler bore.

# Front Section - All Models - continued

## II. Front Section Reassembly - All Models

### B. REASSEMBLY AND POSITIONING OF THE COUNTERSHAFT ASSEMBLIES

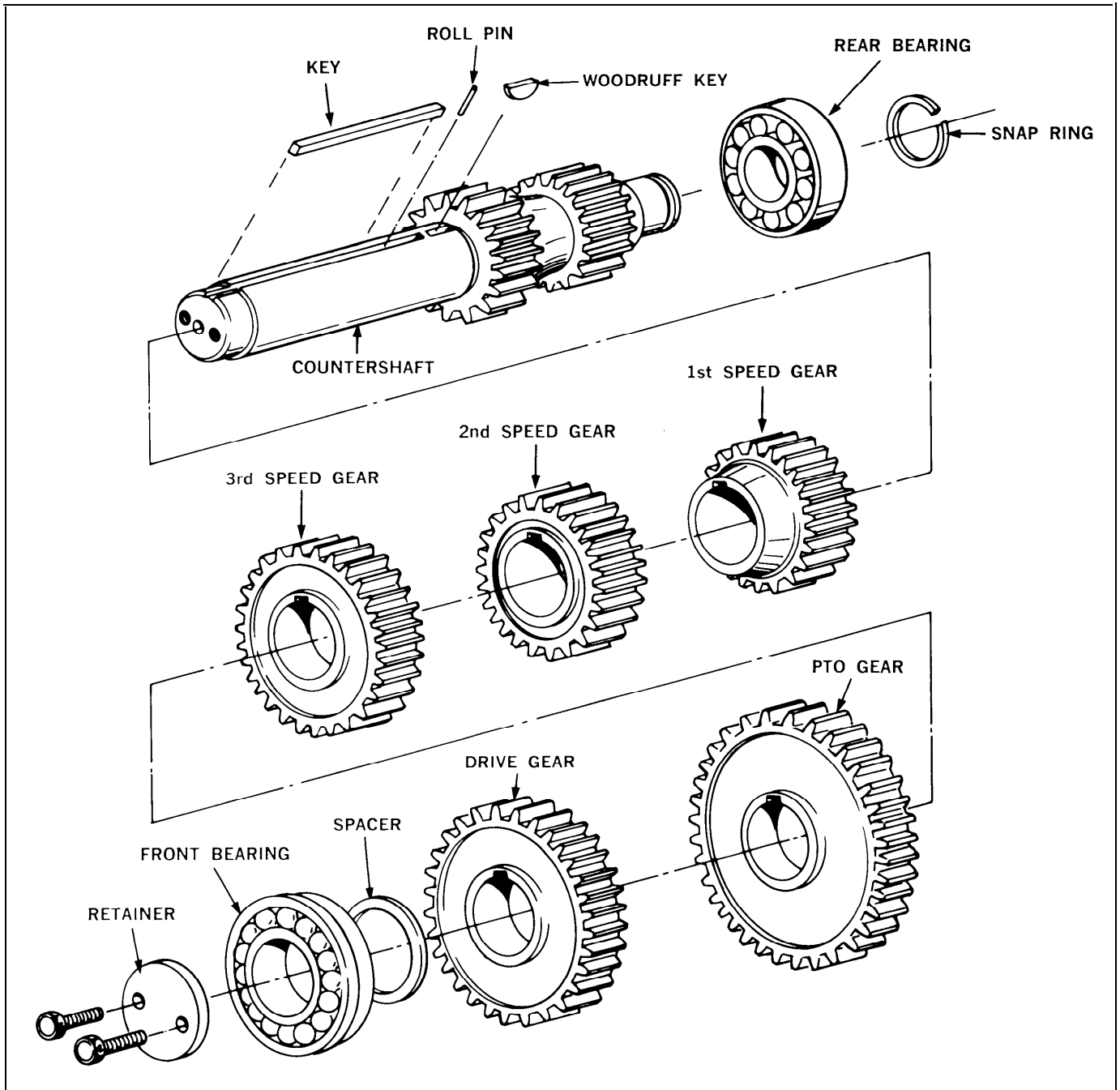

**NOTE:**

Except for the number of teeth on the PTO gears, the countershaft assemblies are identical.

**NOTE:**

It is recommended that the proper Illustrated Parts List be used during reassembly of the countershaft assemblies to provide the proper gear part numbers and locations.

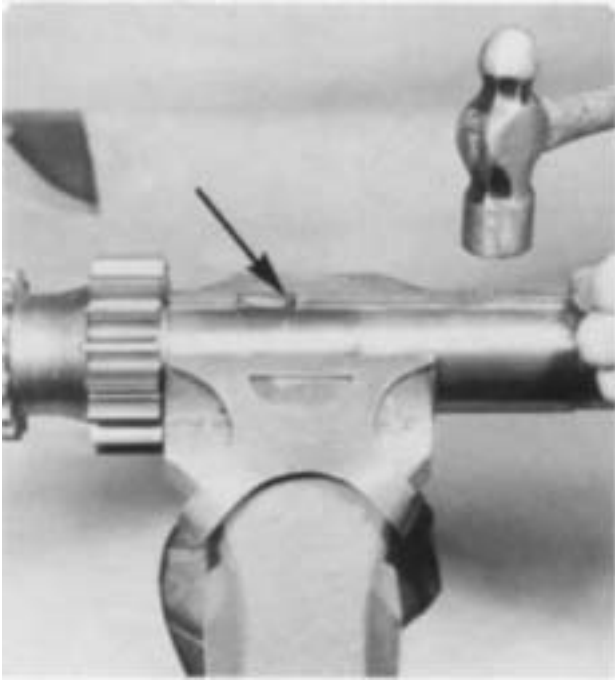

1. If previously removed, install the roll pin, woodruff key and long key on each shaft.

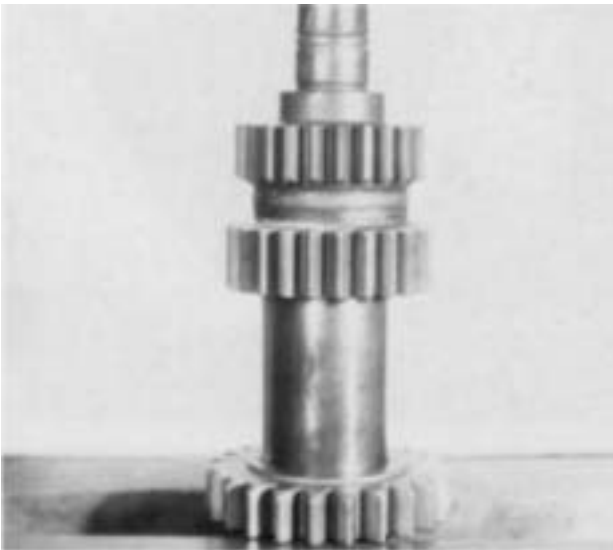

2. Press the first speed gear on the countershaft, long hub down.



3. Press the second speed gear on the shaft, long hub up.

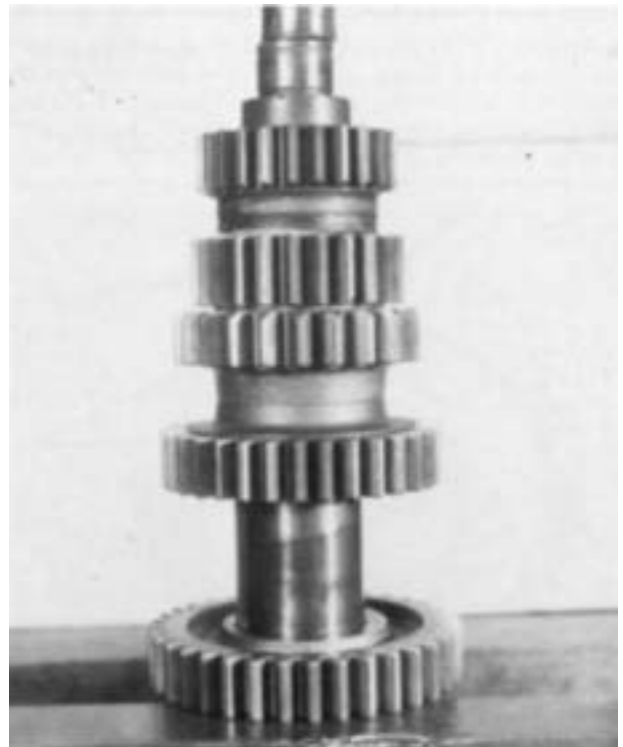

4. Press the third speed or overdrive gear on the shaft, long hub down.

## Front Section - All Models - continued

### II. Front Section Reassembly - All Models

#### B. REASSEMBLY AND POSITIONING OF THE COUNTERSHAFT ASSEMBLIES



5. Start the PTO gear onto the shaft with the rounded side of the teeth facing up. Install the drive gear on the shaft with the long hub facing up and press the PTO and drive gears into position. Install the spacer on the shaft next to the drive gear.

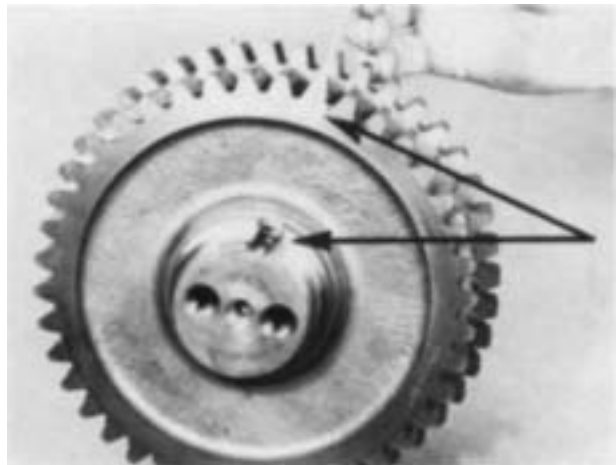

6. On the drive gear of each countershaft, mark the gear tooth which aligns with the keyway in the shaft. This tooth will be stamped with an "O".

NOTE: The left-side countershaft takes a 17-tooth PTO gear; the right side countershaft takes a 15-tooth PTO gear.

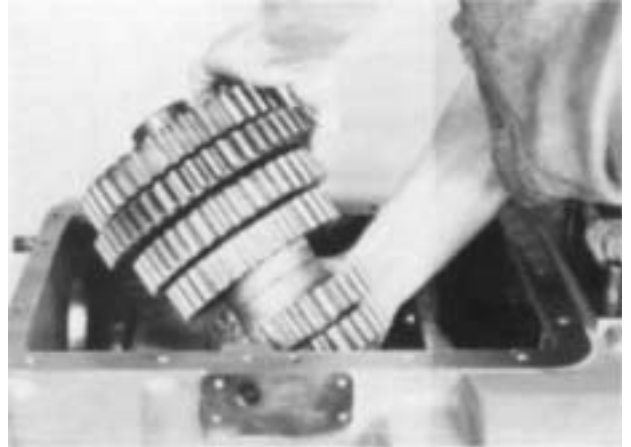

7. Place the left countershaft into position in the case, but do not install bearings. Make sure the left countershaft has the larger 47-tooth PTO gear.



8. Place the right countershaft into position in the case, but do not install bearings. Make sure that the right countershaft has the smaller 45-tooth PTO gear.

## C. REASSEMBLY AND INSTALLATION OF THE DRIVE GEAR ASSEMBLY

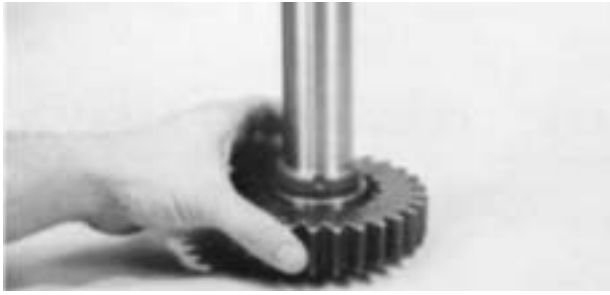

1. If previously removed, install the snap ring in the ID of the drive gear and install the drive gear on the splines of the shaft, snap ring towards the front.



2. Install the spacer on the shaft and against the snap ring.



3. Press the drive gear bearing on the shaft with the shield to the front.



4. Clean the threads on the shaft and the drive gear nut. Apply Loctite, grade AVV to the threads of the drive gearnut.



5. Install the drive gear nut on the shaft threads using 250-300 lbs.-ft. of torque. Peen the nut into the two slots on the shaft.

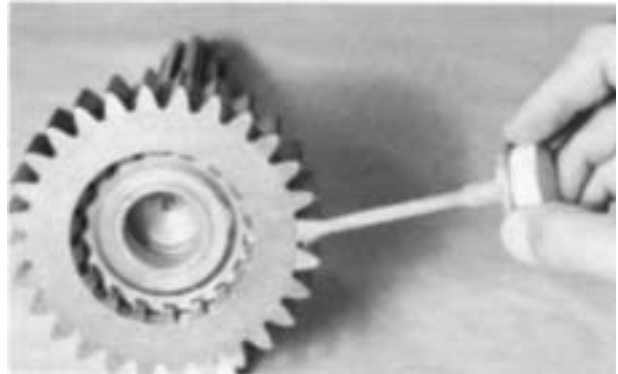

6. Mark any two adjacent teeth on the mainshaft drive gear and ten mark the two teeth directly opposite. Check to make sure that the bushing is in place in the shaft pocket and in good condition. If the bushing has to be replaced, install the new bushing flush into the shaft pocket.



7. Remove the snap ring from the bearing and insert the drive gear assembly through the bore from inside the case, working past the countershafts to seat the bearing in the case boare. Re-install the snap ring in the OD of the bearing.

## Front Section - All Models - continued

### II. Front Section Reassembly - All Models

#### D. TIMING AND INSTALLATION OF THE LEFT COUNTERSHAFT ASSEMBLY

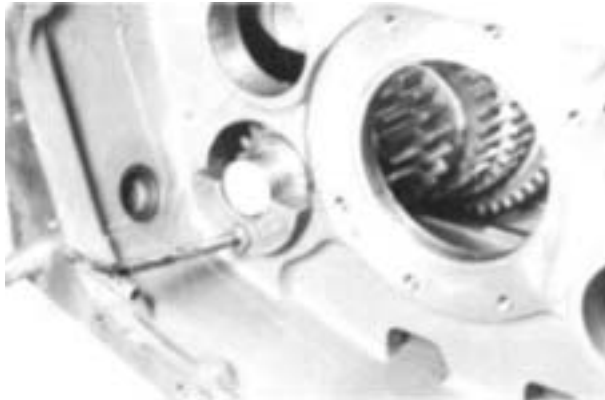

1. Place a centering tool or wood blocks in the case bore to center the rear of the countershaft.

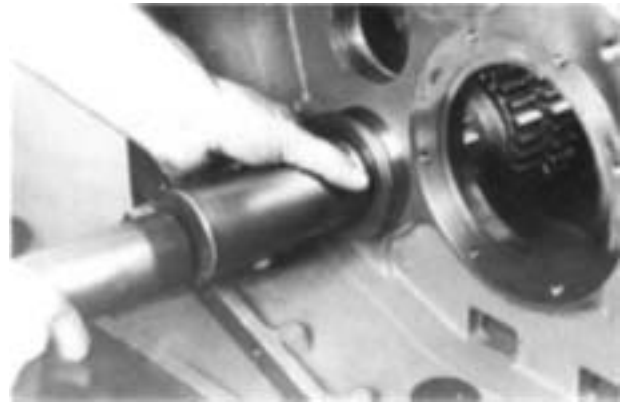

4. Remove the blocking and install the rear bearing.



2. Mesh the marked tooth on the countershaft drive gear between two of the marked teeth on the mainshaft drive gear.



5. Install the retainer plate on the front bearing with the two lockscrews; wire securely.



3. Install the front bearing in the bore and on the shaft.



6. install the snap ring in the groove at the rear of the shaft.

## SETTING CORRECT AXIAL CLEARANCES FOR MAINSHAFT GEARS

Axial Clearance (End Play) Limits Are:  
 Reverse speed gear - Minimum of .005"  
 Forward speed gears - .005" to .012"

Washers are used to obtain the correct limits; six thicknesses are available as follows:

LIMITS	COLOR CODE
.248 -.250	White
.253 -.255	Green
.258 -.260	Orange
.263 -.265	Purple
.268 -.270	Yellow
.73-.275	Black

Refer to Illustrated Parts Lists for washer part numbers. (See page 3).

Always use the low limit washer in the LOW GEAR and 2nd SPEED GEAR positions as shown tit right. Refer to the service manual covering mainshaft reassembly for method of assembling parts.

Reverse gear clearance must be set as low as possible to the minimum .005". Clearance can be measured before the mainshaft assembly is installed in the case. This is done by securing the reverse gear in position on mainshaft with the reverse gear snap ring and the front snap ring; then, secure auxiliary drive gear assembly in position at rear of mainshaft with the rear snap ring. (See page 84. )

\*\*The "LOW", "1st", "2nd" and "3rd" speed gear designations are the nomenclatures for 9- and 13-speed direct models. Gear speeds shown in parentheses are nomenclatures for 10- and 15-speed direct models.

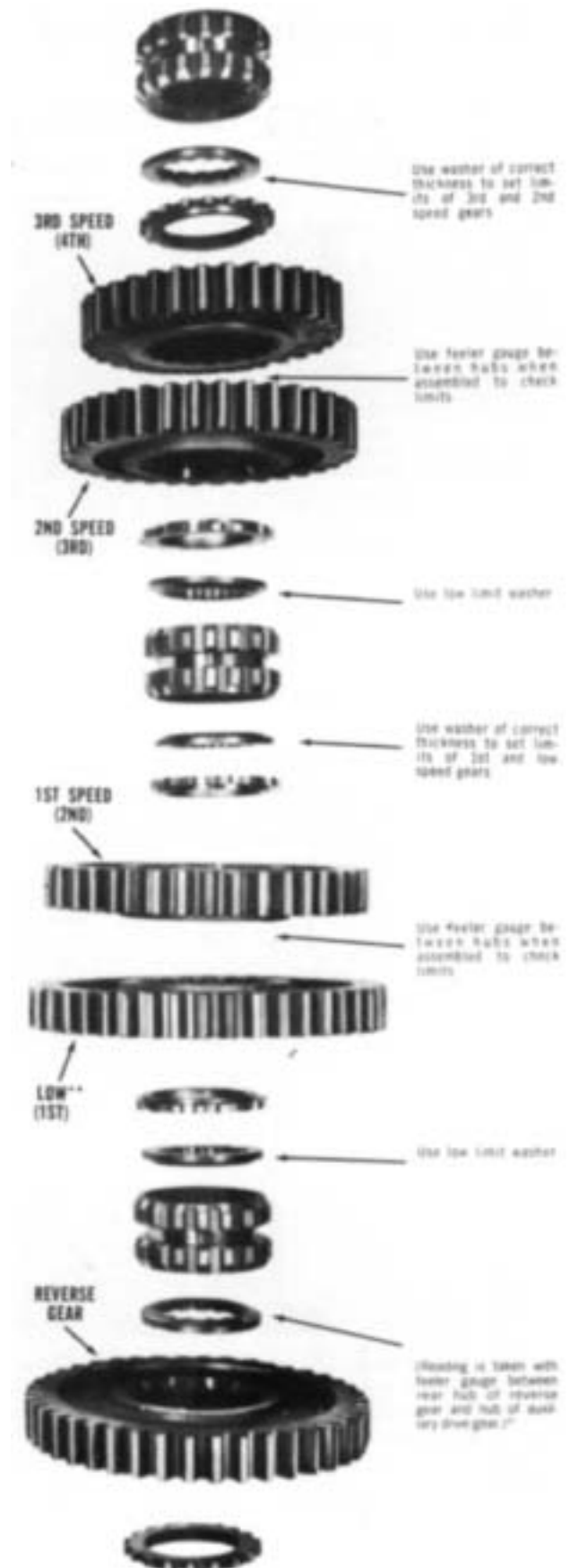



## Front Section - All Models - continued

### II. Front Section Reassembly - All Models

#### E. REASSEMBLY AND INSTALLATION OF THE MAINSHAFT ASSEMBLY

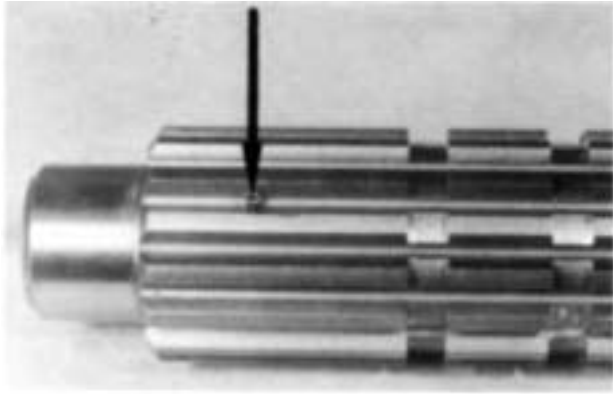

1. If previously removed, install a snap ring in the ID of all mainshaft gears except for the reverse gear. Make sure that the roll pin is in place in the bore between the mainshaft splines. The key bottoms against this roll pin during reassembly.

**NOTE:**

It is recommended that the proper Illustrated Parts List be used during reassembly of the mainshaft to provide the proper gear, washer and spacer part numbers and locations.

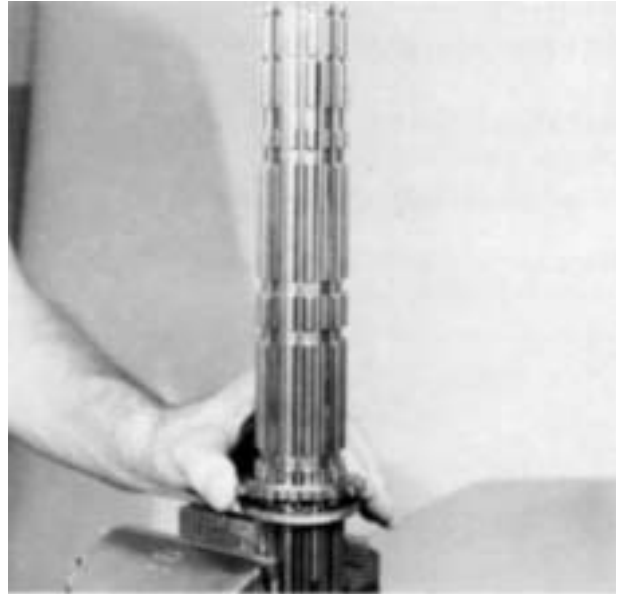

3. Install the spacer on the washer, flat surface down.



2. Secure the mainshaft in a vise with the pilot end down. Do not secure the shaft by the pilot. Install a Low Limit washer as shown with the flat surface up. Secure the washer with the key.

**NOTE:**

When installing washers make sure that the large notch on the internal splines is away from the keyway.

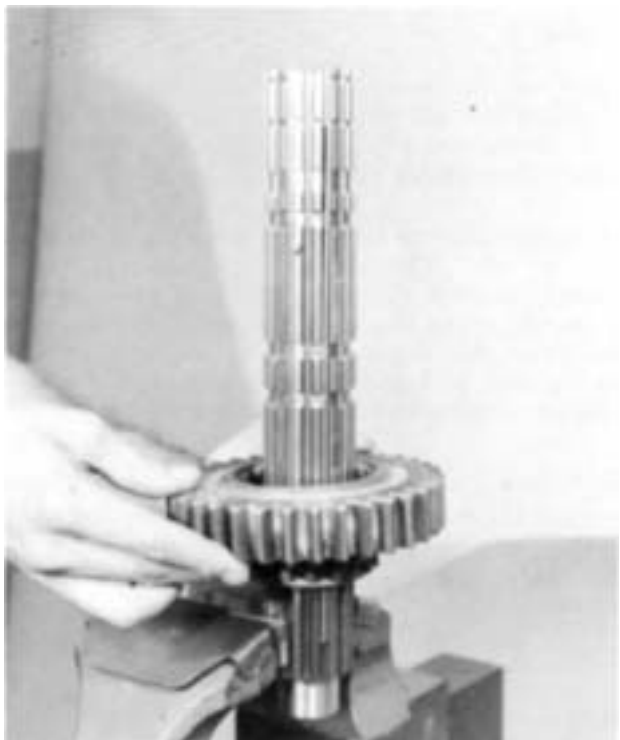

4. Install the third speed or overdrive gear on the spacer, clutching teeth down.



5. Install the second speed gear, clutching teeth up.

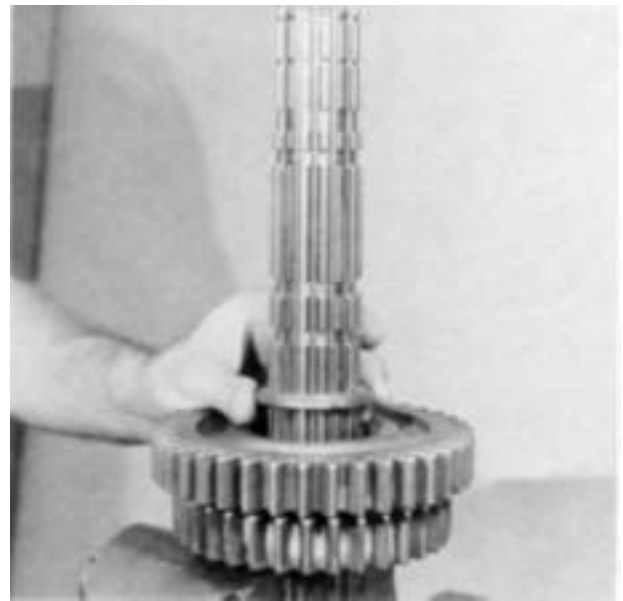

7. Remove the key and install washer with the flat surface down. Turn the washer in the hub of the gear to align with the mainshaft splines, using caution not to turn the gears on the shaft. Use the proper washer to obtain the correct end play. This should be checked with a feeler gauge between the gear hubs. Re-install the key in the keyway.

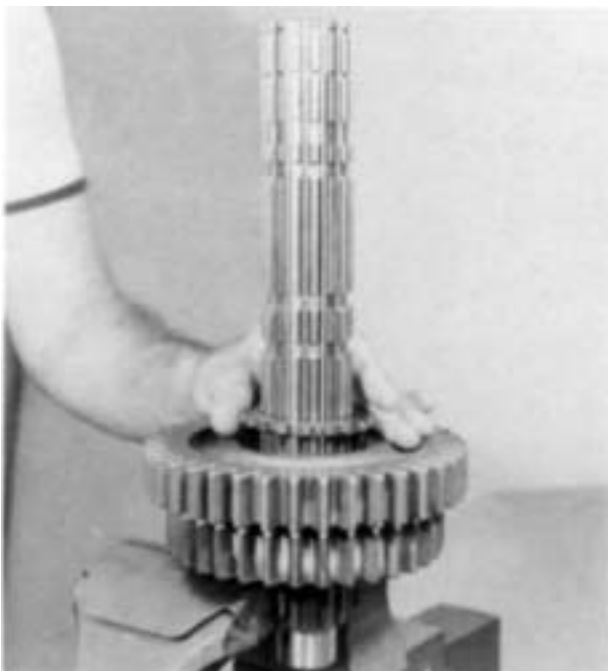

6. Install the spacer in the hub of the gear, flat surface up.

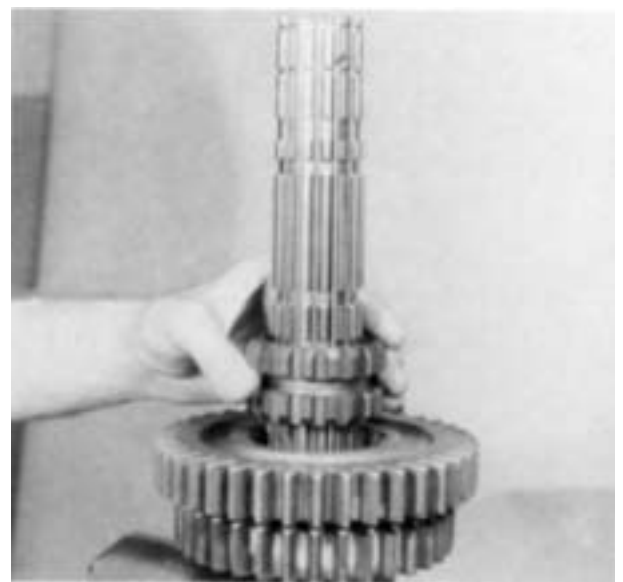

8. Install the sliding clutch with the keyway over the key.

## Front Section - All Models - continued

### II. Front Section Reassembly - All Models

#### E. REASSEMBLY AND INSTALLATION OF THE MAINSHAFT ASSEMBLY



9. Remove the key and install the Low Limit first speed gear washer, flat surface up. Re-install the key.

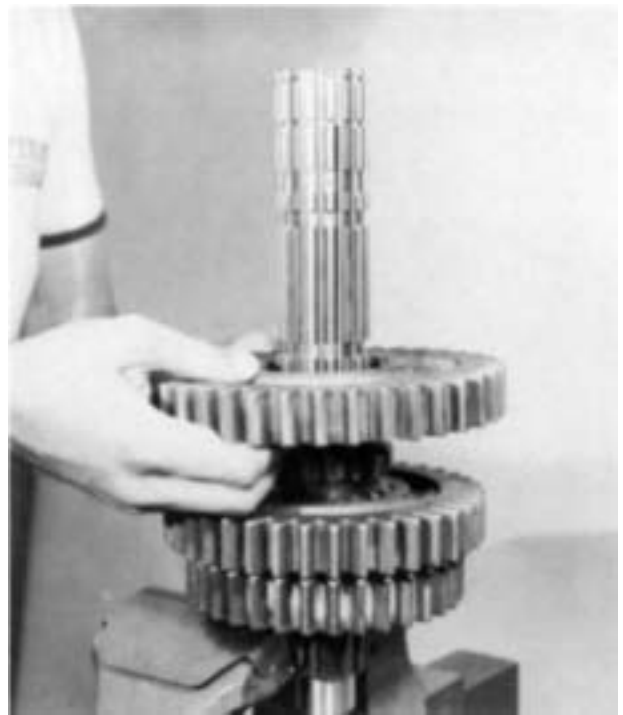

11. Install the first speed gear, clutching teeth down.

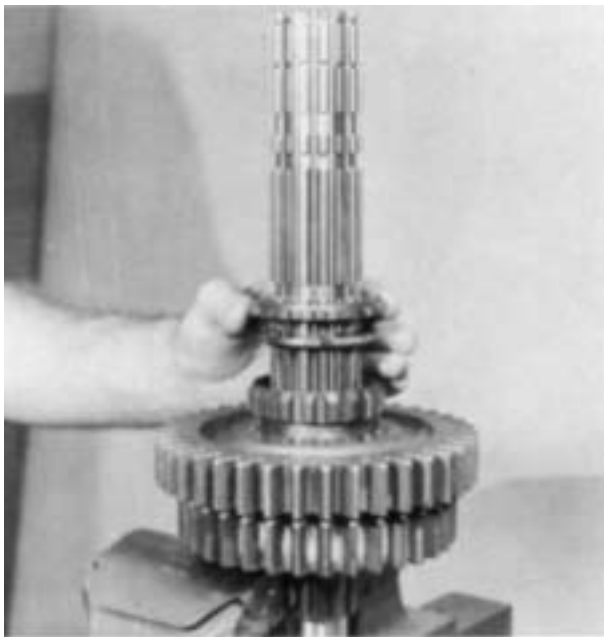

10. Install the spacer on the washer, flat surface down.

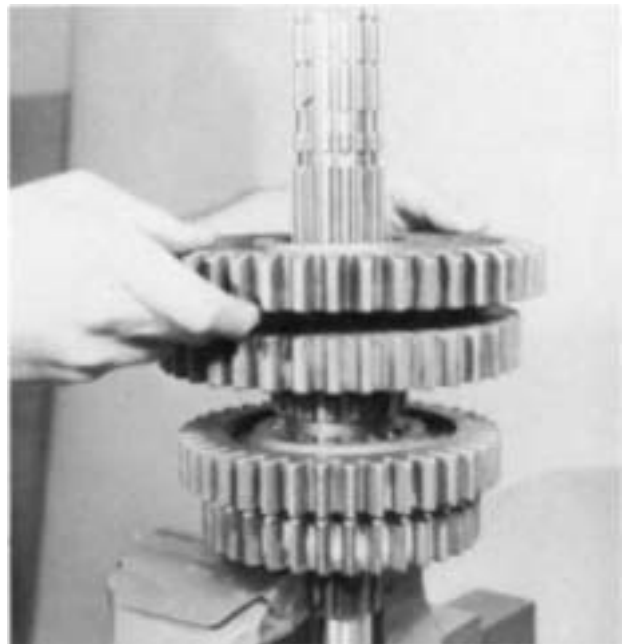

12. Install the low speed gear, clutching teeth up.

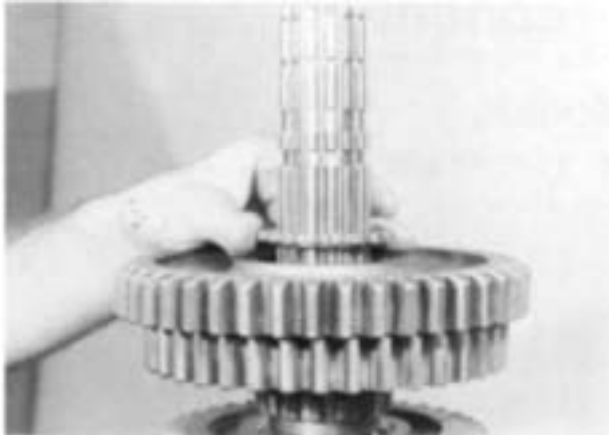

13. Install the spacer in the hub of the gear, flat surface up.

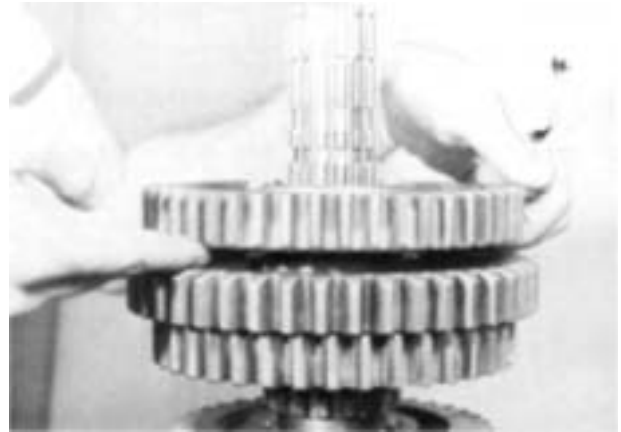

16. Install the reverse gear over the clutch and engage the clutch in the low speed gear so that the two gears are against each other.

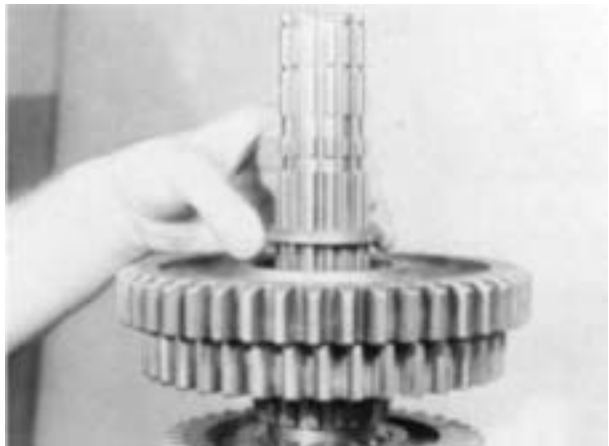

14. Remove the key and install the washer, flat surface down. Turn the washer in the gear hub to align the splines with the mainshaft. Re-install the key and check end play between the gear hubs.

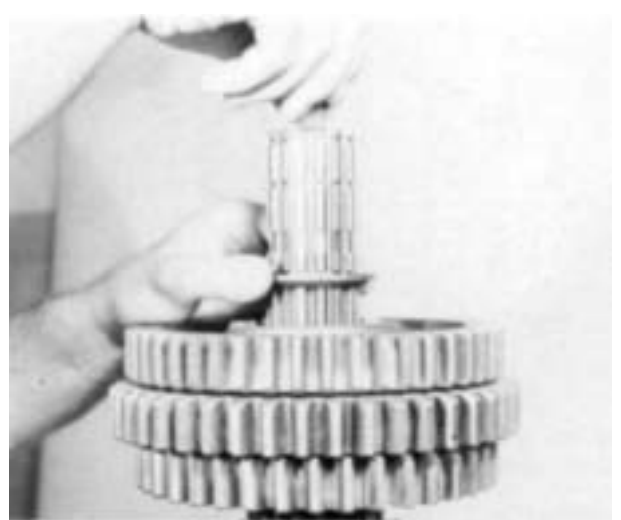

17. Remove the key and install the reverse gear washer, flat surface up. Re-install the key.



15. Install the sliding clutch, aligning the keyway over the key.

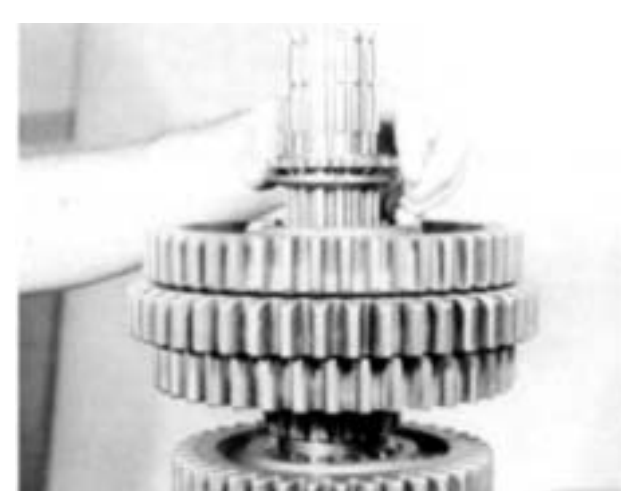

18. Install the spacer, flat surface down.

## Front Section - All Models - continued

### II. Front Section Reassembly - AH Models

#### E. REASSEMBLY AND INSTALLATION OF THE MAINSHAFT ASSEMBLY

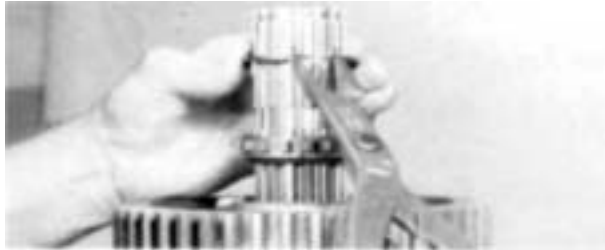

19. Install the snap ring in the indicated position with the opening over the key.

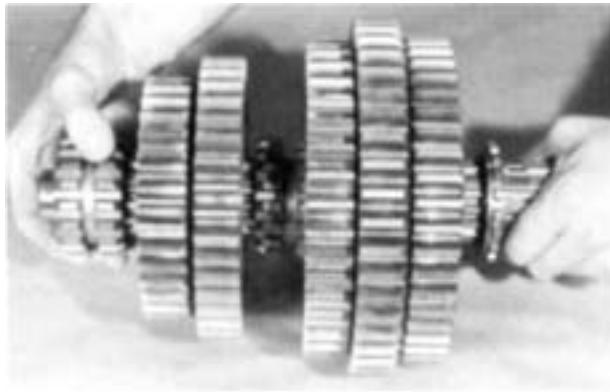

20. Remove the assembly from the vise and install the sliding clutch.



21. From inside the case, insert the rear of the mainshaft through the rear bearing bore and lower the assembly into position. Block the right countershaft against the side of the case and move the mainshaft pilot forward to seat in the pocket of the drive gear shaft.

#### Setting Reverse Gear End-play Limits

After setting the correct axial clearances for the mainshaft forward speed gears (see page 79), secure the mainshaft assembly in a vise with the front end down. Install the snap ring in the hub of the reverse gear and install the gear on the shaft in its proper position with the clutching teeth facing down.

Install the auxiliary drive gear assembly on the shaft in its proper position and secure the assembly to the shaft with the rear mainshaft snap ring. (Photo A)

Insert two screwdrivers between the auxiliary drive gear and the reverse gear and pry upwards. Insert a feeler gauge between the hubs of the reverse gear and the auxiliary drive gear to check clearance. (Photo B)

Use the chart on page 79 to determine the correct washer to use to bring the clearance as close as possible to the minimum .005".

Remove the auxiliary drive gear. Remove the snap ring from the hub of the reverse gear and allow the gear to rest on the first speed gear. Replace the reverse washer on the shaft with the correct thickness washer and proceed with the reassembly.



## F. TIMING AND INSTALLATION OF THE RIGHT COUNTERSHAFT ASSEMBLY

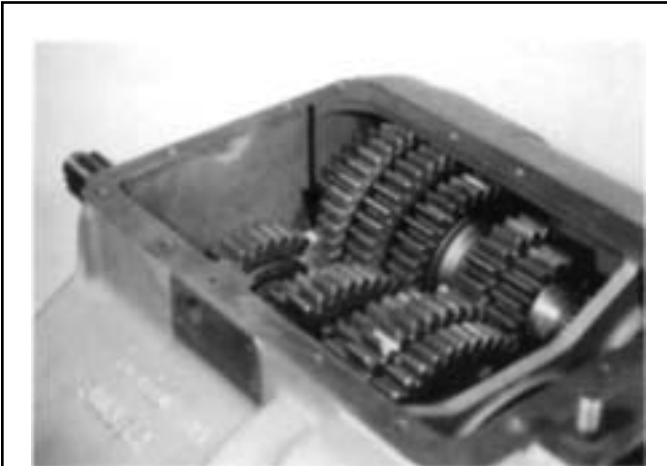

1. Mesh the marked tooth on the countershaft drive gear between the two marked teeth on the mainshaft drive gear making sure that the left countershaft remains in time.

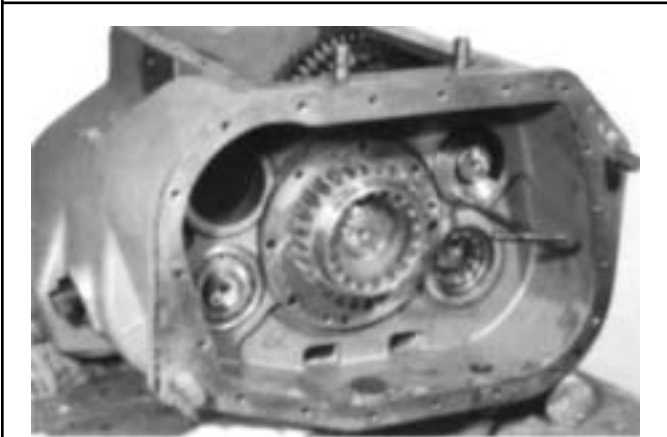

2. Center the rear of both the mainshaft and countershaft in the case bores. Accurate centering of the mainshaft is important. Partially install the auxiliary drive gear assembly to center the rear of the mainshaft.



3. Install the front bearing on the countershaft and in the case bore.

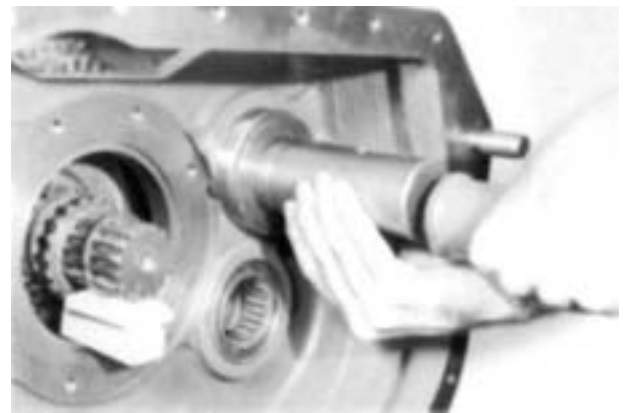

4. Install rear bearing on countershaft and in case bore.



5. Install retainer plate on front of countershaft and wire securely.



6. Install snap ring in groove at the rear of the countershaft.

## Front Section - All Models - continued

### II. Front Section Reassembly - All Models

#### G. REASSEMBLY AND INSTALLATION OF THE LEFT REVERSE IDLER GEAR ASSEMBLY



1. Install the plug in the end of the shaft and slide the cup and bearing inner race on the shaft.

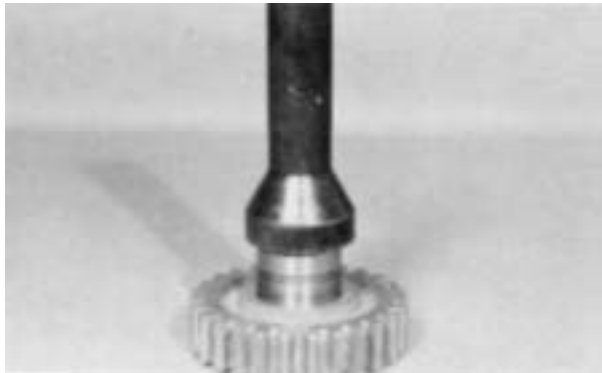

2. Press the needle bearing in the bore of the gear.



3. Place the thrust washer and gear into position making sure that the long hub of the gear faces toward the front of the case. Insert the shaft through the gear and into the bore and seat the shaft in the bore, making sure that the needle bearing is aligned with the inner race.



4. Install the washer and nut on the shaft.



5. Seat the outer race of the auxiliary countershaft front bearing in the reverse idler bore.

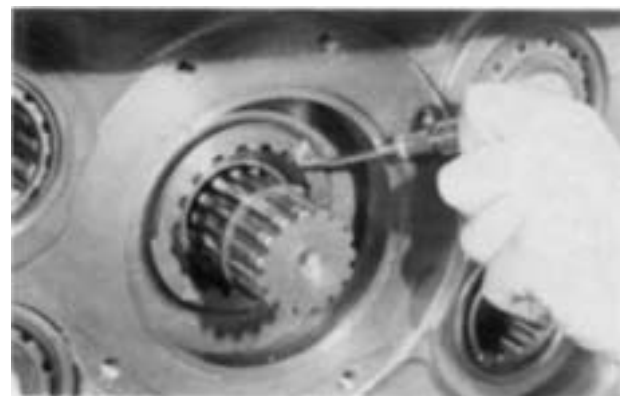

6. Mesh the mainshaft reverse gear with the reverse idler gears and install the snap ring in the ID of the mainshaft reverse gear.

## H. REASSEMBLY AND INSTALLATION OF THE AUXILIARY DRIVE GEAR ASSEMBLY



1. Place the retainer ring on the gear with the flat surface of the ring against the gear.

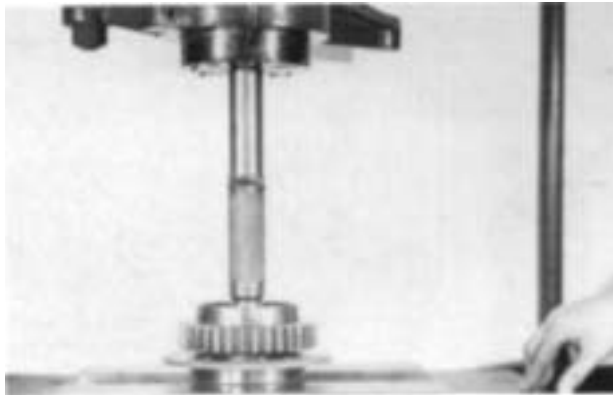

2. Press the bearing on the drive gear with the snap ring facing up.



3. Install the snap ring in the groove in the gear shoulder.



4. Seat the bearing in the rear bore, fitting the gear on the mainshaft splines.



5. Secure the assembly with the six lock screws; wire in groups of three.



6. install the snap ring in the mainshaft groove.



# TORQUE RECOMMENDATIONS

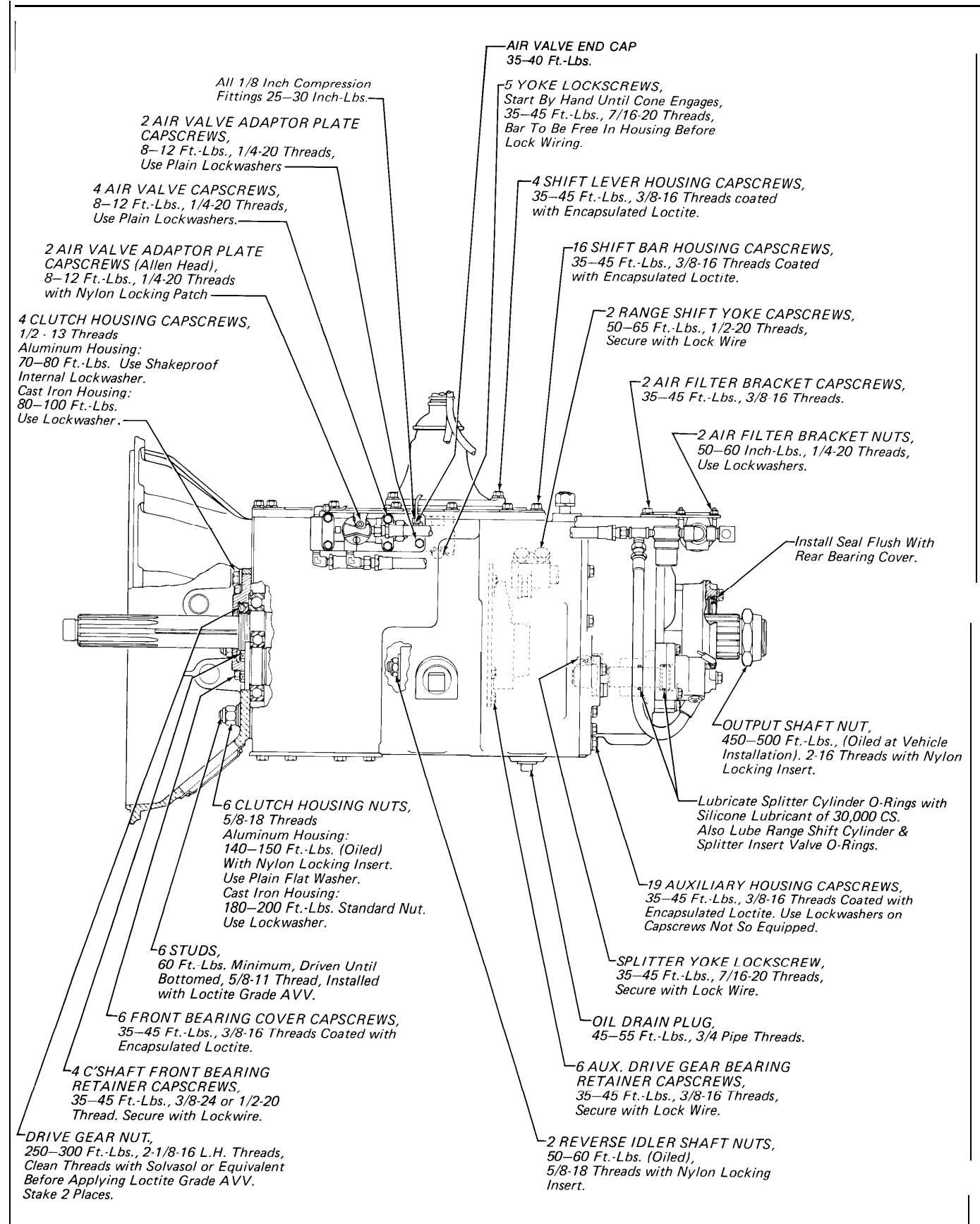

**VIEW OF PLUNGER IN  
LOW AND REVERSE YOKE**

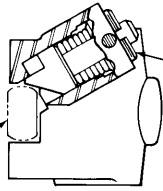

After Installing Plunger and Spring, Tighten Plug and Back Off 1/4 - 1/2 Turns, (T-955 Series 1 - 1-1/4 Turns). Stake Threads in Hole.

SHIFT LEVER.

2 SUPPORT STUDS,  
60 Ft.-Lbs., Minimum, Drive Until Bottomed,  
5/8 Threads Installed with Loctite Grade AVV.  
(When Plugs Are Used In Place Of Studs, Use  
Hydraulic Sealant).

2 SUPPORT STUD NUTS,  
170-185 Ft.-Lbs., (Oiled At Vehicle  
Installation). 5/8-18 Threads,  
Use Lockwashers.

AIR CLEANER PLUG,  
17-21 Ft.-Lbs., 1-1/4-18 Threads.

8 AUX. C'SHAFT REAR BEARING  
COVER CAPSCREWS,  
35-45 Ft.-Lbs., 3/8-16 Threads Coated  
with Encapsulated Loctite.

OIL FILL PLUG,  
60-75 Ft.-Lbs., 1-1/4 Pipe Threads.

8 LARGE P.T.O. COVER CAPSCREWS,  
50-65 Ft.-Lbs., 7/16-14 Threads coated  
with Encapsulated Loctite,  
Use Lockwashers.

4 SPLITTER CYLINDER COVER CAPSCREWS,  
20-25 Ft.-Lbs., 5/16-18 Threads Coated with  
Encapsulated Loctite. Use Lockwashers on  
Capscrews Not So Equipped.

SPLITTER CYLINDER PLUG,  
40-50 Ft.-Lbs., 5/8-18 Threads.

4 HAND HOLE COVER CAPSCREWS,  
20-25 Ft.-Lbs., 5/16-18 Threads.

SHIFT LEVER PIVOT PIN NUT,  
15-20 Ft.-Lbs., 5/16-24 Threads,  
Use Lockwasher.

REVERSE SIGNAL SWITCH PLUG,  
35-50 Ft.-Lbs., 9/16-18 Threads.

4 AUX. RANGE SHIFT CYLINDER  
CAPSCREWS,  
35-45 Ft.-Lbs., 3/8-16 Threads  
Coated with Encapsulated Loctite.

RANGE CYLINDER SHIFT BAR NUT  
70-85 Ft.-Lbs., 5/8-18 Threads with  
Nylon Locking Patch.  
(610 Model, 1/2-13 Threads,  
60-75 Ft.-Lbs., Use Lockwasher).

4 AUX. RANGE SHIFT CYLINDER  
COVER CAPSCREWS,  
35-45 Ft.-Lbs., 3/8-16 Threads Coated  
with Encapsulated Loctite.

6 SMALL P.T.O. COVER CAPSCREWS,  
18-23 Ft.-Lbs., 3/8-16 Threads Coated  
with Encapsulated Loctite.

SPEEDOMETER HOUSING PLUG,  
35-75 Ft.-Lbs., 13/16-20 Threads,  
Use Hydraulic Sealant.

THERMOCOUPLE PLUG,  
40-50 Ft.-Lbs., 1/2 Pipe Threads.

1 REAR BEARING COVER ESLOK  
CAPSCREW,  
35-45 Ft.-Lbs., 3/8-16 Threads,  
Use Brass Flat Washer.

5 REAR BEARING COVER CAPSCREWS,  
35-45 Ft.-Lbs., 3/8-16 Threads,  
Use Lockwashers.

## TOOL REFERENCE

A few special tools are required in the disassembly and reassembly of Fuller transmissions. Although in many instances basic mechanic's tools may be substituted with adequate results, it is highly recommended that the special tools be made or purchased and used to ensure proper results and avoid possible damage to the parts being installed or removed.

Fuller does not make or sell the tools listed, but tool prints and catalogs of known manufacturers of ready-made tools are available upon request. Please mention tool print number and model of transmission when ordering. Write:



**OIL SEAL DRIVER** Print Number T-18088-23  
Used to install the oil seal in the rear bearing housing.



**AUXILIARY PLATE HANGER BRACKET**  
Print Number T-22823

Used to support the auxiliary plate during removal and installation on the front case.

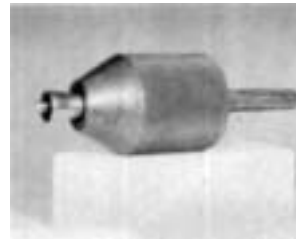

**SNAP RING INSTALLER** Print Number T-16552-1-N  
Used to install the snap ring in the output shaft quill. (RT-12515 Series)

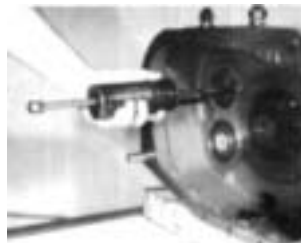
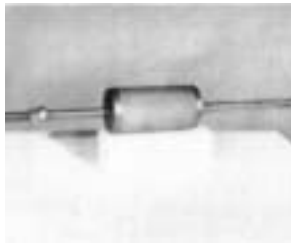

**IMPACT PULLER** Make from 18" steel rod threaded 1/2-13 on one end, attach end block and sliding block.

Used to remove reverse idler shafts.

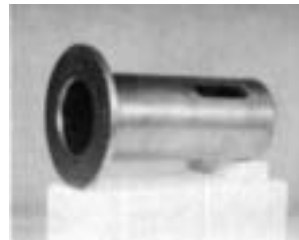

**BEARING DRIVERS** Print Number T-18042 (Dimensions for all drivers necessary on this print.)

Used to install bearings on shafts and in bores.



**DRIVE GEAR BEARING NUT REMOVER**  
Print Number T-22553B  
Print Number T-22553C (For push-type clutches)

Used to remove or install the drive gear bearing nut on the shaft.



**OUTPUT SHAFT HANGER BRACKET** Make from yoke stop nut and flat steel stock.

Used to support the auxiliary section when installed or removed from the front case in the vertical position.

## SPECIAL PROCEDURE FOR CHANGING CLUTCH (INPUT) SHAFT

In some cases in field repair it may be necessary to replace only the input shaft due to clutch wear on the splints.

In these instances the input shaft can be removed without disassembling the transmission other than removing the shifting bar housing. Removal of the clutch housing is optional. Following is the detailed procedure:

### Disassembly

1. Remove gear shift lever housing and shift bar housing from transmission.
2. Remove the front bearing cover.
3. Engage the mainshaft sliding clutches in two gears and remove the drive gear bearing nut.
4. Move the drive gear assembly as far forward as possible and remove the drive gear bearing.
5. Remove the washer from input shaft.
6. From the front, remove the snap ring from ID of drive gear.
7. Pull the input shaft forward and from splines of drive gear.

### Reassembly

1. Install new input shaft into splints of drive gear just far enough to expose snap ring groove in ID of drive gear.
2. Install snap ring in ID of drive gear.
3. Install washer on shaft.
4. Move the fourth-fifth speed sliding clutch gear forward to contact end of input shaft in hub of drive gear. Block between rear of sliding clutch and front of the fourth speed gear. When installing bearing this will hold input shaft in position to seat the bearing properly.
5. Install drive gear bearing on shaft and into case bore, making sure blocking remains in place.
6. Remove blocking from mainshaft and install the drive gear bearing nut, left-hand thread. Use Loctite sealant on threads of nut and shaft.
7. Peen nut into milled slots in shaft.
8. Re-install front bearing cover, shifting bar housing and gear shift lever housing.

### NOTE:

*The above instructions are for changing the input shaft only. To change the drive gear, complete disassembly of the front section must be made.*

Copyright Eaton Corporation, 2012. Eaton hereby grant their customers, vendors, or distributors permission to freely copy, reproduce and/or distribute this document in printed format. It may be copied only in its entirety without any changes or modifications. THIS INFORMATION IS NOT INTENDED FOR SALE OR RESALE, AND THIS NOTICE MUST REMAIN ON ALL COPIES.

**Note:** Features and specifications listed in this document are subject to change without notice and represent the maximum capabilities of the software and products with all options installed. Although every attempt has been made to ensure the accuracy of information contained within, Eaton makes no representation about the completeness, correctness or accuracy and assumes no responsibility for any errors or omissions. Features and functionality may vary depending on selected options.

**For spec'ing or service assistance, call 1-800-826-HELP (4357) or visit [www.eaton.com/roadranger](http://www.eaton.com/roadranger). In Mexico, call 001-800-826-4357.**

Roadranger: Eaton and trusted partners providing the best products and services in the industry, ensuring more time on the road.

**Eaton Corporation**

Vehicle Group  
P.O. Box 4013  
Kalamazoo, MI 49003 USA  
800-826-HELP (4357)  
[www.eaton.com/roadranger](http://www.eaton.com/roadranger)

Printed in USA

For parts or service call us  
Pro Gear & Transmission, Inc.



**1 (877) 776-4600**

**(407) 872-1901**

**parts@eprogear.com**

**906 W. Gore St.**

**Orlando, FL 32805**

