

Fuller Heavy Duty Transmissions TRSM0503

October 2007

RTX-12510
RTX-12515
RTXF-12510
RTXF-12515



Powering Business Worldwide

BACKED BY

Roadranger

SUPPORT

For parts or service call us
Pro Gear & Transmission, Inc.



1 (877) 776-4600

(407) 872-1901

parts@eprogear.com

906 W. Gore St.

Orlando, FL 32805



Table of Contents

Model Designations	Inspection
Description	Torque Ratings
Specifications	Reassembly Precautions
Lubrication	Reassembly Instructions
Operation	I. Auxiliary Section-RT-1110 Series
Air Systems	A. Output Shaft
Preventive Maintenance	B. Synchronizer
Changing Input Shaft	C. Auxiliary Countershafts
Disassembly Precautions	D. Range Shift Cylinder
Disassembly Instructions	II. Auxiliary Section –RT-12510 Series
I. Shifting Controls	A. Output Shaft
A. Deep Reduction Air System (RT-12515)	B. Synchronizer
B. Range Shift Air System	C. Auxiliary Countershafts
C. Gear Shift Lever Housing	D. Range Shift Cylinder
D. Shift Bar Housing	III. Auxiliary Section –RT-12515 Series
II. companion Flange, Auxiliary Housing and Clutch Housing	A. Output Shaft
111. Front Section	B. Range Mainshaft
A. Auxiliary Drive Gear	C. Deep Reduction Shift Cylinder
B. Left Reverse Idler Gear	D. Low Range Gear
C. Countershaft Bearings	E. Synchronizer
D. Mainshaft	F. Auxiliary Countershafts
E. Drive Gear	G. Range Shift Cylinder
F. Countershafts	IV. Front Section
G. Right Reverse Idler Gear	A. Right Reverse Idler Gear
IV. Auxiliary Section –RT-1110 Series	B. Countershafts
A. Range Shift Cylinder	C. Countershaft Installation
B. Auxiliary Countershafts	D. Drive Gear
C. Synchronizer	E. Drive Gear Installation
D. Low Speed Gear and Output Shaft	F. Left Countershaft Timing
V. Auxiliary Section –RT-12510 Series	Mainshaft Axial Clearances
A. Range Shift Cylinder	G. Mainshaft
B. Auxiliary Counershafts	H. Mainshaft Installation
C. Synchronizer	I. Left Reverse Idler Gear
D. Output Shaft	J. Mainshaft Final Installation
VI. Auxiliary Section –RT-12515 Series	K. Auxiliary Drive Gear
A. Range Shift Cylinder	V. Companion Flange, Auxiliary Housing and Clutch Housing
B. Auxiliary Counterhafts	VI. Shifting Controls
C. Synchronizer	A. Shift Bar Housing
D. Low Range Gear and Range Mainshaft	B. Gear Shift Lever Housing
E. Deep Reduction Shift Cylinder	C. Air System
F. Output Shaft	Tool Reference

Model Designations

- RT-III O— Roadranger transmission, twin countershaft, 10 speeds, 1100 lbs./ft. torque capacity.
- RTO-1 110 — Roadranger transmission, twin countershaft, 10 speeds, including an overdrive ratio, 1100 lbs.-ft. torque capacity.
- RT-12510 — Roadranger transmission, twin countershaft, 10 speeds, 1250 lbs./ft. torque capacity.
- RTO-12510 — Roadranger transmission, twin countershaft, 10 speeds, including an overdrive ratio, 1250 lbs.-ft. torque capacity.
- RT-12515 — Roadranger transmission, twin countershaft, 15 speeds, 1250 lbs./ft. torque capacity
- RTO-1 2515 — Roadranger transmission, twin countershaft, 15 speeds, including an overdrive ratio, 1250 lbs.-ft. torque capacity.
- “F” — Included in letter designation before numerals, such as RTF-12510, etc. denotes forward position of the gear shift lever.

NOTE

Illustrated parts lists with part numbers are available upon request. Write Service Department, Eaton Corporation, Transmission Division, 222 Mosel Avenue, Kalamazoo, Michigan 49007.

Description

The RT-111 O and RT-12510 transmissions are designed for heavy-duty on-highway equipment. The twin countershaft design, which splits torque equally between the two shafts, provides a high torque capacity to weight ratio. Because of torque splitting, each gear set carries only half the load, greatly reducing the face width of each gear.

Another unique design feature is the floating gear principle. The mainshaft gears when not engaged “float” between the countershaft gears, eliminating the need for gear sleeves and bushings. All gears are in constant mesh and have spur type teeth.

The RT-111 O and RT-12510 transmissions have ten forward speeds and two reverse, consisting of a five-speed front section and a two-speed auxiliary or range section, both contained in one case. First through fifth speeds are obtained by using the five gear ratios in the front section

through the low speed gear of the range section. Sixth through tenth speeds are obtained by using the five gear ratios in the front section through the high speed (direct drive) range gear. As in other Roadranger transmissions, the ratios are progressively spaced.

The RT-125 15 transmissions have 15 forward speeds and three reverse, consisting of a five-speed front section, which is identical to the RT-1 110 and RT-12510 front section, and a three-speed auxiliary or range section. Both sections are contained in one case, the rear plate being extended to accommodate the extra set of gears. The 15 speeds are obtained by using the five speeds of the front section through direct drive (high range), through the low speed range gear, and through the hole-gear of the auxiliary section. The hole-gear in the RT-12515 transmissions is engaged by air when selected by the driver.

10-speed Transmission

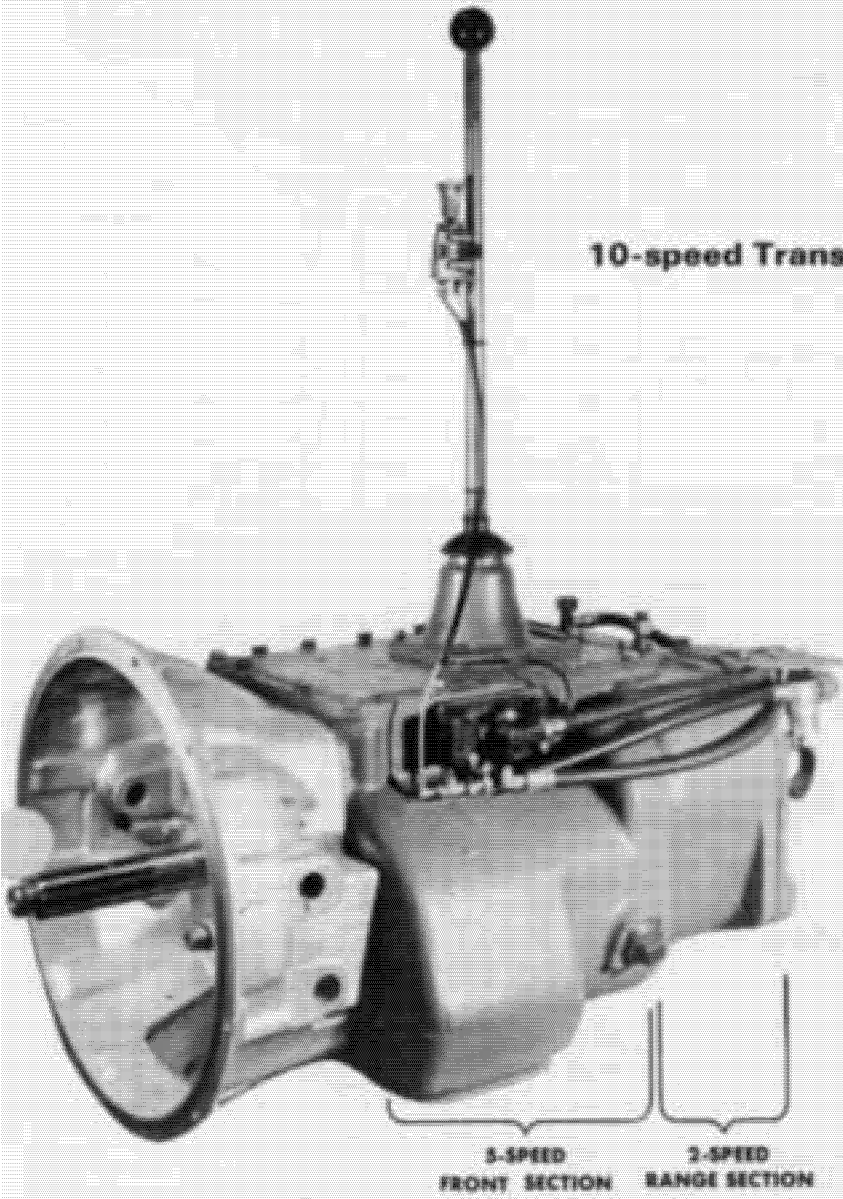

15-speed Transmission

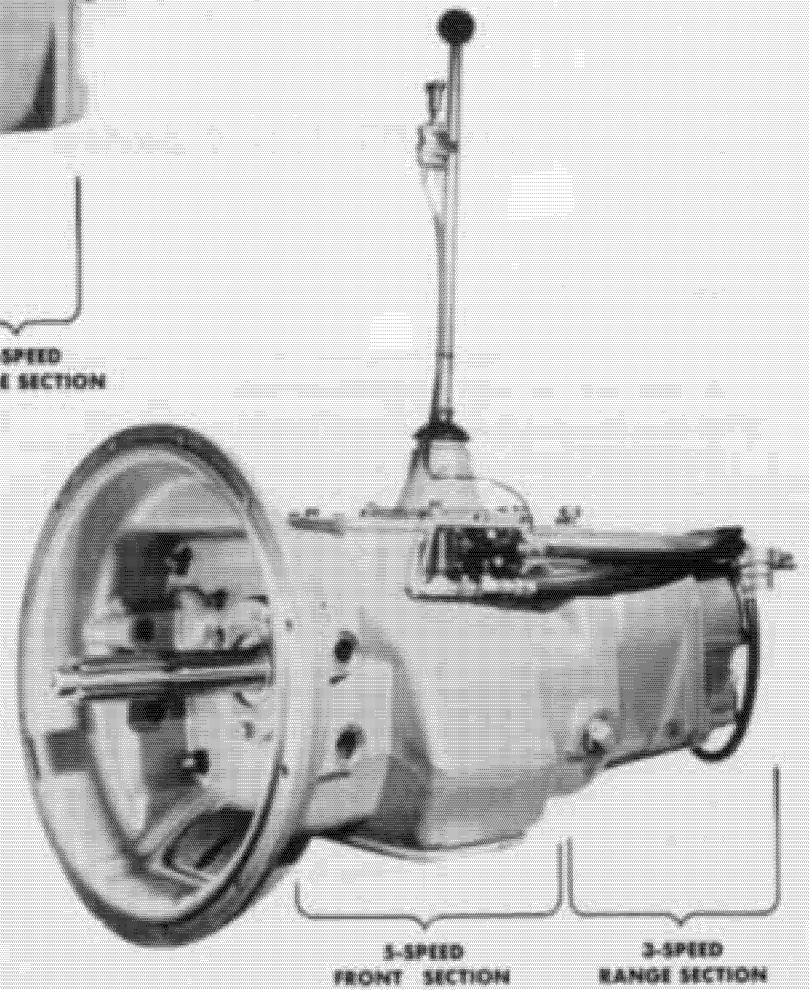

Specifications

Specifications - RT-1 110 Series

Speeds 10 progressive forward speeds, 2 reverse

Nominal Torque Capacity 1100 lb.-ft.

Input Drive Shaft 2" diameter

Power Take-Off

Openings

Right Side: SAE standard 6 bolt regular duty type, short length. High Range
 Bottom: SAE standard 8-bolt heavy-duty type.

PTO Gear Relative Speed to Input R.P. M.

Right Side: 45-tooth 6/8 pitch gear turning at .700 engine speed on RT-1 110 and RTF-1 110 models; .888 engine speed on RTO-1 110 and RTOF-1 110 models.

Bottom: 47-tooth 6/8 pitch gear turning at .700 engine speed on RT-1 110 and RTF-1 110 models; .888 engine speed on RTO-1 110 and RTOF-1 110 models. Low Range

Weight

SAE No. 1 aluminum clutch housing with standard controls, less clutch release parts – 620 lbs.

Oil Capacity

Approximately 25 pints, depending on inclination of engine and transmission. Fill to level of case filler opening.

GEAR RATIOS							
RT-1110 and RTF-1110				RTO-1 110 and RTOF-1 110			
SPEED	RATIO	%	STEP	SPEED	RATIO	%	STEP
10th	1.00		27	10th	.79		27
9th	1.27		30	9th	1.00		30
8th	1.65		28	8th	1.30		28
7th	2.11		30	7th	1.66		30
6th	2.74		30	6th	2.16		29
Range Shift				Range Shift			
5th	3.55		27	5th	2.79		27
4th	4.50		30	4th	3.55		30
3rd	5.83		28	3rd	4.59		28
2nd	7.49		30	2nd	5.90		30
1st	9.71			1st	7.65		
High Reverse	2.74			High Reverse	2.16		
Low Reverse	9.71			Low Reverse	7.65		

Specifications - RT-1 2510 Series

Speeds 10 progressive forward speeds, 2 reverse.

Nominal Torque Capacity 1250 lb.-ft.

Power Take-Off

Openings

Right Side: SAE standard 6-bolt regular duty type, short length. High Range
 Bottom: SAE standard 8-bolt heavy-duty type.

PTO Gear Relative Speed to Input R.P.M.

Right Side: 45-tooth 6/8 pitch gear turning at .700 engine speed on RT-1 2510 and RTF-12510 models; .888 engine speed on RTO-1 2510 and RTOF-12510 models.

Bottom: 47-tooth 6/8 pitch gear turning at .700 engine speed on RT-12510 and RTF-1 2510 models; .888 engine speed on RTO-1 2510 and RTOF-12510 models. Low Range

Weight

SAE No. 1 clutch housing with standard controls, less clutch release parts – 698 lbs.

Clutch Housing Size

SAE No. 1 deep only, 6-5/8", for push or pull type clutches.

Oil Capacity

Approximately 25 pints, depending on inclination of engine and transmission. Fill to level of case filler opening.

GEAR RATIOS							
RT-12510 and RTF-12510				RTO-125 10 and RTOF-12510			
SPEED	RATIO	%	STEP	SPEED	RATIO	%	STEP
10th	1.00		27	10th	.79		27
9th	1.27		29	9th	1.00		30
8th	1.65		28	8th	1.30		28
7th	2.11		30	7th	1.66		30
6th	2.74		29	6th	2.16		29
Range Shift				Range Shift			
5th	3.55		27	5th	2.79		27
4th	4.50		29	4th	3.55		30
3rd	5.83		28	3rd	4.59		28
2nd	7.49		30	2nd	5.90		30
1st	9.71			1st	7.65		
High Reverse	2.74			High Reverse	2.16		
Low Reverse	9.71			Low Reverse	7.65		

Specifications - RT-1 2515 Series

Speeds

15 forward speeds, 3 reverse. Five deep reduction ratios, plus evenly spaced ratios for a selective 11 or 12 progressive ratios.

Nominal Torque Capacity

1250 lb.-ft.

Power Take-Off

Openings

Right Side: SAE standard 6-bolt regular duty type, short length.

Bottom: SAE standard 8-bolt heavy-duty type.

PTO Gear Relative Speed to Input R.P. M.

RT-12515 and RTF-12515

Right Side: 45-tooth 6/8 pitch gear turning .700 engine speed.

Bottom: 47-tooth 6/8 pitch gear turning .700 engine speed.

RTO-12515 and RTOF-12515

Right Side: 45-tooth 6/8 pitch gear turning .888 engine speed.

Bottom: 47-tooth 6/8 pitch gear turning .888 engine speed.

Clutch Housing Size

SAE No. 1 deep only, 6-5/8", for push or pull type clutches.

Weight

SAE No. 1 clutch housing, with standard controls, less clutch release parts – 770 lbs.

Oil Capacity

Approximately 28 pints, depending on inclination of engine and transmission. Fill to level of case filler opening.

GEAR RATIOS					
RTO-12515 and RTOF-125 15					
RANGE					
RATIO	% STEP	SPEED	% STEP	RATIO	% STEP
				.79	10th
				1.00	27 9th
				1.30	30 8th
				1.66	28 7th
				2.16	30 6th
		29		2.79	27 5th
				3.55	30 4th
3.99		5th	12	4.59	30 3rd
5.07	27	4th	10	5.90	28 2nd
6.56	29	3rd	11	7.65	30 1st
8.43	28	2nd	10		
10.93	29	1st			

Deep Red. Range

High Range

Low Range

High Reverse 2.16
 Low Reverse 7.65
 Deep Reduction Reverse 10.93

GEAR RATIOS					
RT-12515 and RTF-12515					
RANGE					
RATIO	% STEP	SPEED	% STEP	RATIO	% STEP
				1.00	10th
				1.27	27 9th
				1.65	29 8th
				2.11	28 7th
				2.74	30 6th
		29		3.55	27 5th
				4.50	29 4th
5.07		5th	12	5.83	27 3rd
6.43	27	4th	10	7.49	28 2nd
8.34	30	3rd	11	9.71	30 1st
10.70	28	2nd	10		
13.87	29	1st			

Deep Red. Range

High Range

Low Range

High Reverse 2.74
 Low Reverse 9.71
 Deep Reduction Reverse 13.87

LUBRICATION

Proper Lubrication . . . the Key to long transmission life

Proper lubrication procedures are the key to a good all-around maintenance program. If the oil is not doing its job, or if the oil level is ignored, all the maintenance procedures in the world are not going to keep the transmission running or assure long transmission life.

Eaton® Fuller® Transmissions are designed so that the internal parts operate in a bath of oil circulated by the motion of gears and shafts.

Thus, all parts will be amply lubricated if these procedures are closely followed:

1. **Maintain oil level. Inspect regularly.**
2. **Change oil regularly.**
3. **Use the correct grade and type of oil.**
4. **Buy from a reputable dealer.**

Lubrication Change and Inspection

Eaton® Roadranger® CD50 Transmission Fluid	
HIGHWAY USE—Heavy Duty and Mid-Range	
First 3,000 to 5,000 miles (4827 to 8045 Km)	Factory fill Initial drain
Every 10,000 miles (16090 Km)	Check fluid level Check for leaks
Heavy Duty Highway Change Interval	
Every 250,000 miles (402336 Km)	Change transmission fluid,
Mid-Range Highway Change Interval	
Every 100,000 miles (160,000 Km) or every 3 years whichever occurs first	Change transmission fluid.
OFF-HIGHWAY USE	
First 30 hours	Factory fill Initial drain,
Every 40 hours	Inspect fluid level Check for leaks
Every 500 hours	Change transmission fluid where severe dirt conditions exist.
Every 1,000 hours	Change transmission fluid (Normal off-highway use),
Heavy Duty Engine Lubricant or Mineral Gear Lubricant	
HIGHWAY USE	
First 3,000 to 5,000 miles (4827 to 8045 Km)	Factory fill Initial drain.
Every 10,000 miles (16090 Km)	Inspect lubricant level, Check for leaks,
Every 50,000 miles (80450 Km)	Change transmission lubricant,
OFF-HIGHWAY USE	
First 30 hours	Change transmission lubricant on new units
Every 40 hours	Inspect lubricant level Check for leaks
Every 500 hours	Change transmission lubricant where severe dirt conditions exist.
Every 1,000 hours	Change transmission lubricant (Normal off-highway use),

Change the oil filter when fluid or lubricant is changed.

Recommended Lubricants		
Type	Grade (SAE)	Fahrenheit (Celsius) Ambient Temperature
Eaton® Roadranger® CD50 Transmission Fluid	50	All
Heavy Duty Engine Oil	50	Above 10°F(-12°C.)
MI L-L-2104B C or D or API-SF or API-CD	40	Above 10°F(-12°C.)
(Previous API designations acceptable)	30	Below 10°F(-12°C.)
Mineral Gear Oil with rust and oxidation Inhibitor	90 80W	Above 10°F(-12°C.) Below 10°F(-12°C.)
API-GL-1		

The use of mild EP gear oil or multi-purpose gear oil is not recommended, but if these gear oils are used, be sure to adhere to the following limitations:

Do not use mild EP gear oil or multi-purpose gear oil when operating temperatures are above 230°F (110°C). Many of these gear oils, particularly 85W140, break down above 230°F and coat seals, bearings and gears with deposits that may cause premature failures. If these deposits are observed (especially a coating on seal areas causing oil leakage), change to Eaton Roadranger CD50 transmission fluid, heavy duty engine oil or mineral gear oil to assure maximum component life and to maintain your warranty with Eaton. (Also see "Operating Temperatures".)

Additives and friction modifiers are not recommended for use in Eaton Fuller transmissions.

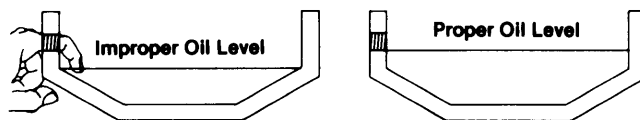

Proper Oil Level

Make sure oil is level with filler opening. Because you can reach oil with your finger does not mean oil is at proper level. One inch of oil level is about one gallon of oil.

Draining Oil

Drain transmission while oil is warm. To drain oil remove the drain plug at bottom of case. Clean the drain plug before re-installing.

Refilling

Clean case around filler plug and remove plug from side of case. Fill transmission to the level of the filler opening. If transmission has two filler openings, fill to level of both openings.

The exact amount of oil will depend on the transmission inclination and model. Do not over fill—this will cause oil to be forced out of the transmission.

When adding oil, types and brands of oil should not be mixed because of possible incompatibility.

LUBRICATION

Operating Temperatures —With Eaton® Roadranger® CD50 Transmission Fluid Heavy Duty Engine Oil and Mineral Oil

The transmission should not be operated consistently at temperatures above 250°F (120°C). However, intermittent operating temperatures to 300°F (149°C) will not harm the transmission. Operating temperatures above 250°F increase the lubricant's rate of oxidation and shorten its effective life. When the average operating temperature is above 250°F, the transmission may require more frequent oil changes or external cooling.

The following conditions in any combination can cause operating temperatures of over 250°F: (1) operating consistently at slow speeds, (2) high ambient temperatures, (3) restricted air flow around transmission, (4) exhaust system too close to transmission, (5) high horsepower, overdrive operation.

External oil coolers are available to reduce operating temperatures when the above conditions are encountered.

Transmission Oil Coolers are:

Recommended

- With engines of 350 H.P. and above with overdrive transmissions

Required

- With engines 399 H.P. and above with overdrive transmissions and GCW'S over 90,000 lbs.
- With engines 399 H.P. and above and 1400 Lbs.-Ft. or greater torque
- With engines 450 H.P. and above

— With EP or Multipurpose Gear Oil

Mild EP gear oil and multipurpose gear oil are not recommended when lubricant operating temperatures are above 230°F (110). In addition, transmission oil coolers are not recommended with these gear oils since the oil cooler materials may be attacked by these gear oils. The lower temperature limit and oil cooler restriction with these gear oils generally limit their success to milder applications.

Proper Lubrication Levels as Related to Transmission Installation Angles

If the transmission operating angle is more than 12 degrees, improper lubrication can occur. The operating angle is the transmission mounting angle in the chassis plus the percent of upgrade (expressed in degrees).

The chart below illustrates the safe percent of upgrade on which the transmission can be used with various chassis mounting angles. For example: if you have a 4 degree transmission mounting angle, then 8 degrees (or 14 percent of grade) is equal to the limit of 12 degrees. If you have a 0 degree mounting angle, the transmission can be operated on a 12 degree (21 percent) grade.

Anytime the transmission operating angle of 12 degrees is exceeded for an extended period of time the transmission should be equipped with an oil pump or cooler kit to insure proper lubrication.

Note on the chart the effect low oil levels can have on safe operating angles. Allowing the oil level to fall 1/2" below the filler plug hole reduces the degree of grade by approximately 3 degrees (5.5 percent).

Proper Lubrication Levels are Essential!

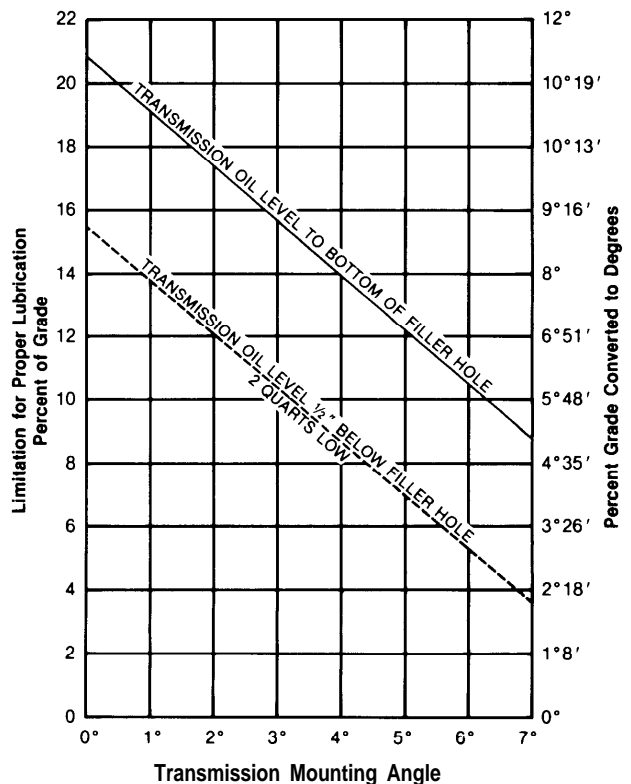

Dotted line showing "2 Quarts Low" is for reference only. Not recommended.

Operation

In the following instructions, it is assumed that the driver is familiar with motor trucks and tractors, and that he can coordinate the necessary movements of the shift lever and clutch pedal to make progressive and selective gear engagements in either direction, up or down.

RT-1 110 and RT-12510 Operation

The RT-1 110 and RT-12510 have ten selective ratios, evenly and progressively spaced. Do not shift these transmissions as you would a conventional model with an auxiliary or two-speed axle, because there is no split-shifting.

All shifts are made with one lever. The range control button is used one time only during an upshift sequence, and one time only during a downshift sequence.

Since the transmissions consist of a five-speed front section and a two-speed range section, the ten forward speeds are obtained by using a five-speed shifting pattern twice – the first time with the transmission in low range, and the second time with the transmission in high range.

Ten speeds obtained with one gear shift lever and range control button.

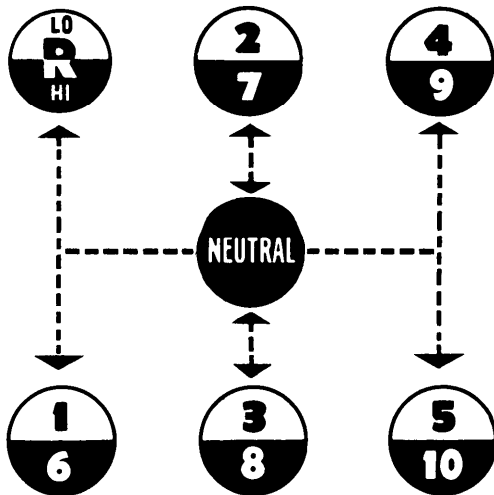

Shift pattern for the RT-1110 and R T-1251 O model transmissions.

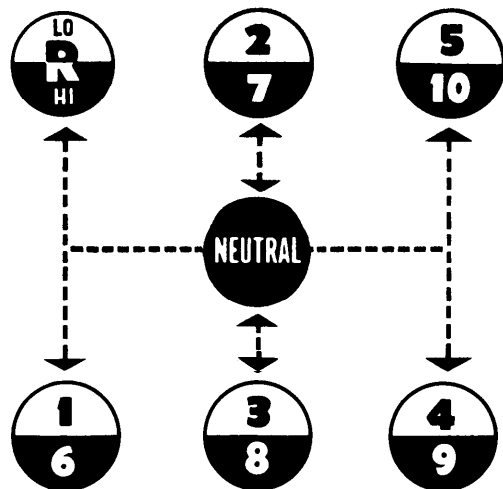

Shift pattern for the R TO-1110 and RTO-12510 model transmissions.

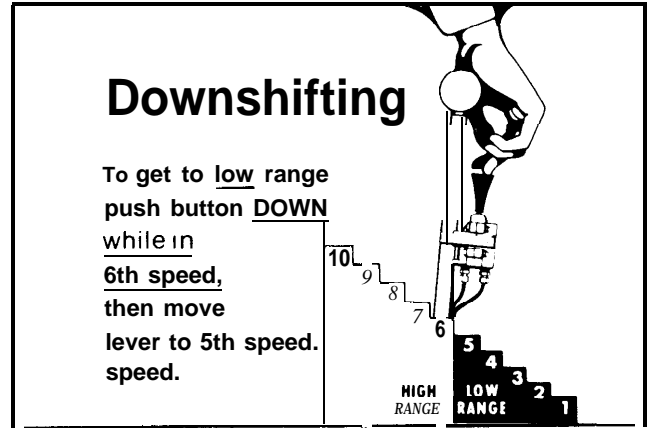
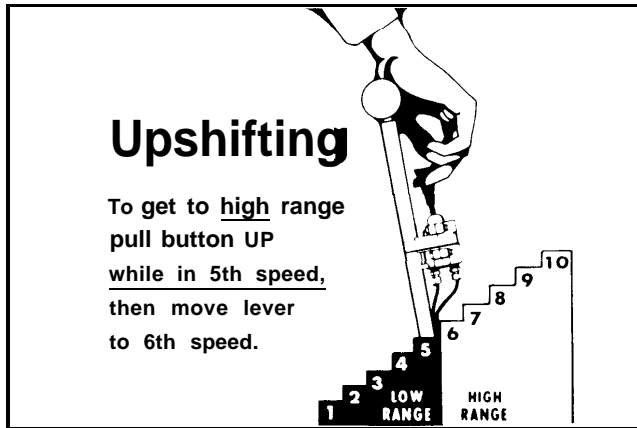

Upshifting

1. Move the gearshift lever to the neutral position.
2. Start the engine.
3. Wait for air system to reach normal line pressure.
4. Now look at the Range Control Button. If it is **up** push it to the down position. (With the downward movement of the button, the transmission will shift into low range.) If the button **was** down when the truck was last used, the transmission is already in low range.
5. Now start the vehicle and shift progressively through 1st, 2nd, 3rd and 4th to 5th.
6. When in 5th and **ready for the next upward shift**, **PULL** the Range Control Button **UP** and move the lever to 6th speed. As the lever **passes through the neutral position**, the transmission will automatically shift from low range to high range.
7. With the transmission in high range, you may now shift progressively through 7th, 8th and 9th to 10th.

Driving tip: always start vehicle moving in first speed gear.

Downshifting

1. When shifting down, move the lever from 10th through each successive lower speed to 6th.
2. When in 6th, and **ready for the next downward shift**, **PUSH** the Range Control Button **DOWN** and move the lever to 5th speed. As the lever **passes through the neutral position**, the transmission will automatically shift from high range to low range.
3. With the transmission in low range, shift downward through each of the four remaining steps.

General Instructions

The shift through neutral is important only on the first shift made after the control button is moved. Subsequent shifts through neutral will not activate the automatic range shift until the control button is moved once more.

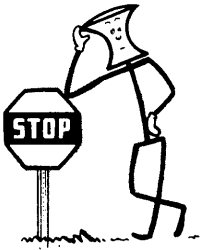

When necessary to slow or stop the vehicle, shift down through the individual short steps, allowing the compression of the engine to slow the vehicle. The life of chassis and trailer brakes can thus be prolonged.

When slowing the vehicle, it is also permissible to coast in high range with the clutch disengaged. The shift to low range, however, should not be made until it is necessary to accelerate the vehicle once more.

Shifts will be fast and short as the gear shift lever stroke is 2½ inches between positions. Conical engagement teeth are standard on these transmissions, thus helping to eliminate gear clashing. Gear ratios average 26 per cent between ratio steps.

Skip Shifting

After becoming proficient in shifting this transmission, the operator may wish to skip some of the gear ratios to offset a particular Operating condition. Skip shifting can be

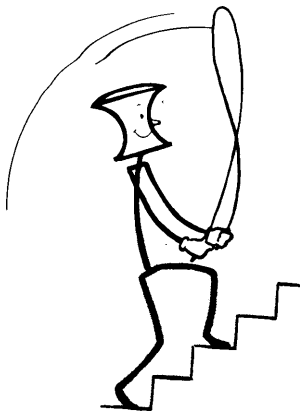

done when upshifting providing the range control button is pulled up to the high range position before making any shift which passes fifth speed.

Skip shifting is also possible during downshifting providing the range control button is pushed down to the low range position before making any shift which passes sixth speed.

Precautions

To protect the transmission from abuse, the following precautions should be observed when shifting the vehicle:



1. Do not attempt to shift from high range to low range at high vehicle speeds. This downward range shift should be made only at a road speed equal to that provided by fifth or a lower gear at governed engine speed.

2. Do not attempt to make any range shifts either up or down when the vehicle is moving in reverse. Stay in the range originally selected.

A mylar shift diagram is furnished with each transmission and should be installed on the vehicle dashboard. If it has been misplaced, new mylar shift diagrams can be purchased from the Service Department, Transmission Division, Eaton Corporation, Kalamazoo, Michigan.

RT-12515 and RTO-12515 Operation

The RT-125 15 transmission, like the RT-125 10, has a five-speed front section and a two-speed auxiliary or range section which enables the driver to select 10 forward speeds, evenly and progressively spaced. However, the RT-125 15 models have an additional five speeds obtained through a deep reduction gear (hole-gear).

The 10 ratios in high and low range are obtained with one lever and a range control button. The five speeds in deep reduction are obtained with the same gearshift lever and a Deep Reduction Valve which controls the "IN" or "OUT" position of the reduction gear.

The five ratios in deep reduction are evenly and progressively spaced. These five ratios, however, overlap the low range ratios and are not progressively spaced in relation to the low range ratios.

The deep reduction gear should be used only when

operating under adverse conditions and only when the transmission is in LOW RANGE with the control valve button down. Never move the Deep Reduction Valve to "IN" when in high range. When the valve is moved to "IN" the reduction ratios will be engaged regardless of the position of the Range Control Button.

The **RTO-12515** is operated in the same manner as the RT-125 15 except for the reversal of the 4th and 5th gear-shift lever positions.

Upshift Through Low and High Range

Shift upward through the 10 speeds of low and high range in the same manner as upshifting the RT-12510 or RTO-12510 model transmissions. **MAKE SURE THE DEEP REDUCTION VALVE IS IN THE "OUT" POSITION AT ALL TIMES** during the low and high range shifts.

SHIFTING DIAGRAM OF THE RT-12515

Fifteen speeds obtained with one gear shift lever, a Range Control Button and a Deep Reduction Valve. (Ratios shown with each gear shift lever position.)

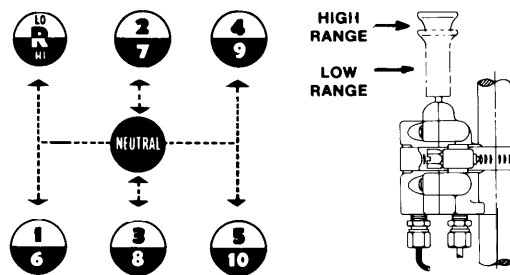

One through 10 speeds . . . with Range Control Button . . . and Deep Reduction gear disengaged.

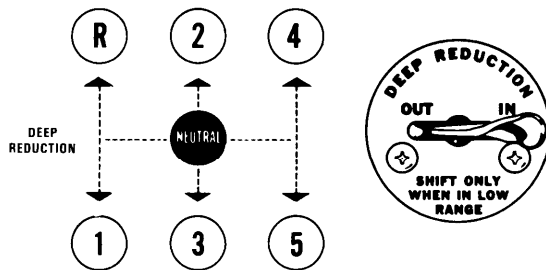

Five additional ratios . . . with Deep Reduction gear engaged.

SHIFTING DIAGRAM OF THE RTO-12515

Fifteen speeds obtained with one gear shift lever, a Range Control Button and a Deep Reduction Valve. (Ratios shown with each gear shift lever position.)

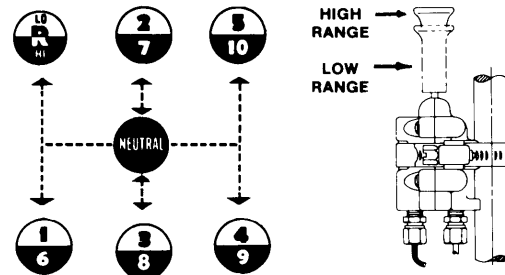

One through 10 speeds . . . with Range Control Button . . . and Deep Reduction gear disengaged.

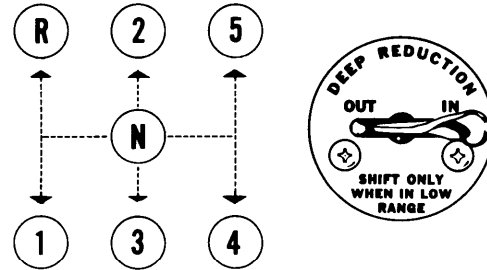

Five additional ratios . . . with Deep Reduction gear engaged.

SUGGESTED SHIFT PATTERN FOR THE RT-12515 THROUGH REDUCTION AND LOW AND HIGH RANGE

(Ratios shown next to each gear shift lever position)

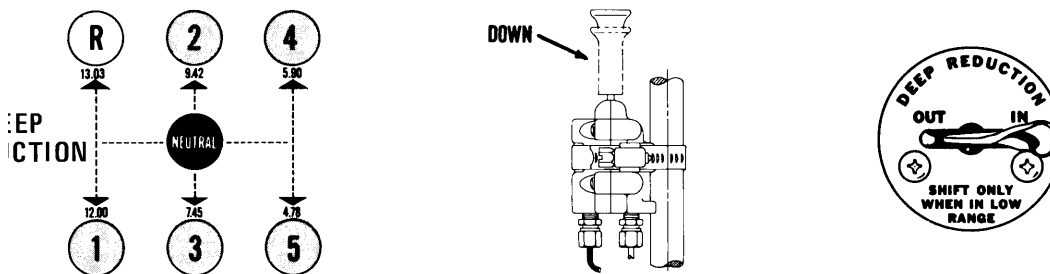

Shift 1 through 5 with range control button down and deep reduction valve to "IN"

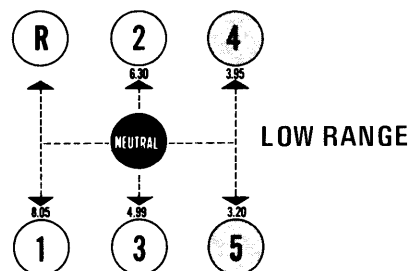

Move deep reduction valve to "OUT" while in 5th reduction . . . and shift through 4th & 5th of low range

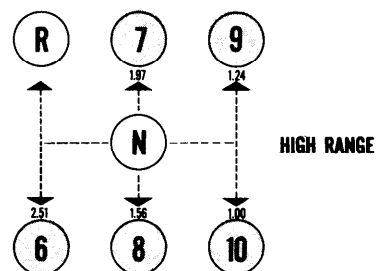
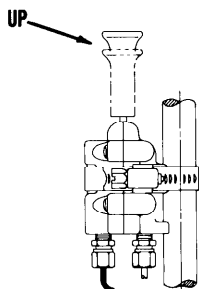

Pull range control button up while in 5th of low range . . . and shift 6th through 10th

Upshift Through Deep Reduction, Low and High Range

There are several patterns of upshifting depending upon conditions of road and load. Check gear ratios to determine the best ratio split for your particular condition. The following instructions are recommended for average conditions:

1. With the gearshift lever in neutral, the engine started and air system pressure normal, PUSH THE RANGE CONTROL BUTTON TO THE DOWN POSITION.
2. Move the Deep Reduction Valve to the "IN" position to engage the deep reduction gear.
3. Start the vehicle and shift progressively from 1st through 5th of the shift pattern.
4. When in 5th speed position and ready for the next upshift, move the Deep Reduction Valve to the "OUT" position and shift to the 4th speed position, thus shifting

out of the reduction ratios to low range ratios. Torque will keep the reduction gear engaged until the shift out of fifth position is made. Remember, although **the** shift lever is moved from 5th to 4th, this is an upshift and accelerator must be moved accordingly. There will be no automatic range shift as the transmission already is in low range.

5. Shift through the 4th and 5th speed positions of low range.
6. When ready for the next upshift, pull the Range Control Button up while in the 5th speed position of low range and shift the lever to the first speed position of the shift pattern. As the lever passes through neutral, the transmission will automatically shift from low to high range.
7. Shift progressively upward from 6th through 10th in high range.

NOTE: The above is for the RT-12515. The RTO-12515 shift from reduction to low range would differ, according to the ratios desired.

Important Procedures

1. When making the shift from a reduction ratio to a low range ratio, move the Deep Reduction Valve from “IN” to “OUT” IMMEDIATELY BEFORE making the shift. This is not a pre-select valve and only torque will hold the reduction gear after the lever is moved to “OUT”; the shift cylinder will make the shift by air as soon as torque is released.
2. Never move the Deep Reduction Valve lever with the transmission in high range (range control button up) as the reduction gear bypasses both the low and high range sections, regardless of the position of the range control button.
3. When downshifting it should not be necessary to shift into deep reduction ratios. The reduction in low range should be sufficient in most operating conditions.

All instructions pertaining to the Range Control Button, skip shifting and general precautions of the ten-speed shift pattern of the RT-1 110 and RT-12510 apply as well to the RT-12515.

Air Systems

Range Shift Air System – All Models

This system consists of an air filter, regulator, air valve, control valve, shift cylinder, fittings and connecting lines. See Illustration A.

Constant regulated air is supplied to the bottom port of the air valve and to the “IN” port of the control valve. With the control button down, air passes through the control valve and to the end port of the air valve. This permits air from the constant supply to flow through the low range port in bottom, side cap of air valve and to the shift cylinder air port. Air on this port moves the shift piston and bar to the rear to engage the low range gear.

With the control button up the control valve is closed and air is removed from end port of air valve. This permits air

from the constant supply to flow through the high range port in rear, side cap of air valve and to the shift cylinder cover air port. Air on this port moves the shift piston and bar forward to engage the high range gear.

When the control button is moved from one position to another, air from the previously charged line exhausts through the breather in air valve.

On some transmissions the air valve may be installed in a 180° position from that shown in Illustration A. The porting on these models, however, remains the same. The bottom port in the side cap is always the low range port.

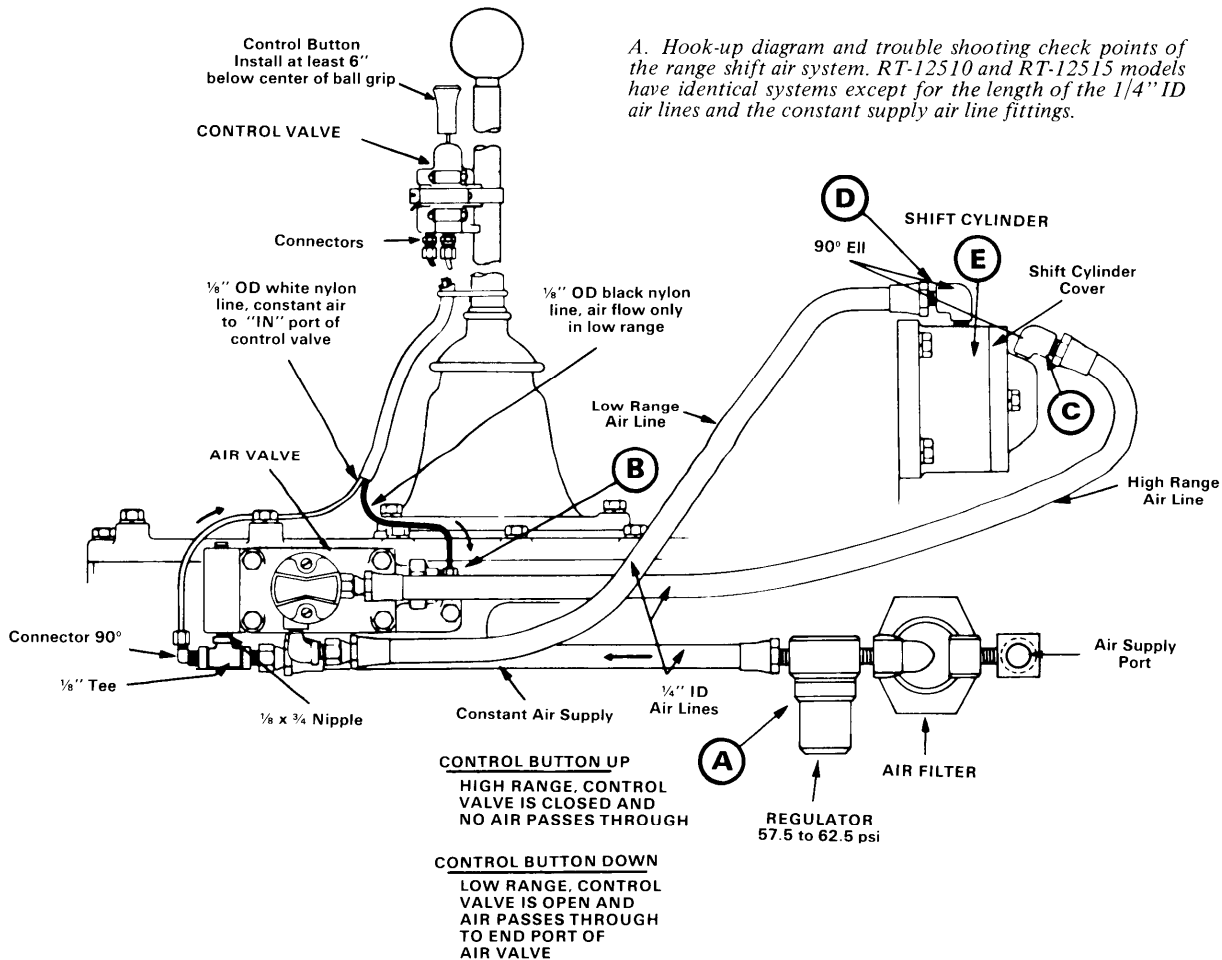

Hole-Gear Air System – RT-12515 Series

This system uses the air filter and regulator of the range shift air system, plus a Deep Reduction Valve, mounted in the vehicle's cab, and a hole-gearshift cylinder. See Illustration B.

Constant regulated air is supplied to the end port of the deep reduction valve and to the air port in the lower, right side of the hole-gearshift cylinder cover.

The deep reduction valve lever has two positions, "IN" and "OUT". With the lever moved to the "IN" position the valve is off. Thus, constant air channeled through the shift

cylinder and cover to the front of the shift piston moves the piston and shift bar to the rear to engage the hole-gear. As the hole-gear is engaged the range mainshaft is disengaged from the output shaft, removing the low and high range sections from the power flow.

With the deep reduction valve lever moved to the "OUT" position air flows out the side port of the valve and to the air port near the center of the hole-gearshift cylinder cover. This air, pushing against a larger piston area than the constant air supply, moves the shift piston and bar forward to disengage the hole-gear. As the hole-gear is disengaged, the range mainshaft is engaged to the output shaft, permitting use of the low and high range sections.

B. Hook-up diagram and troubleshooting checkpoints for the hole-gear air system.

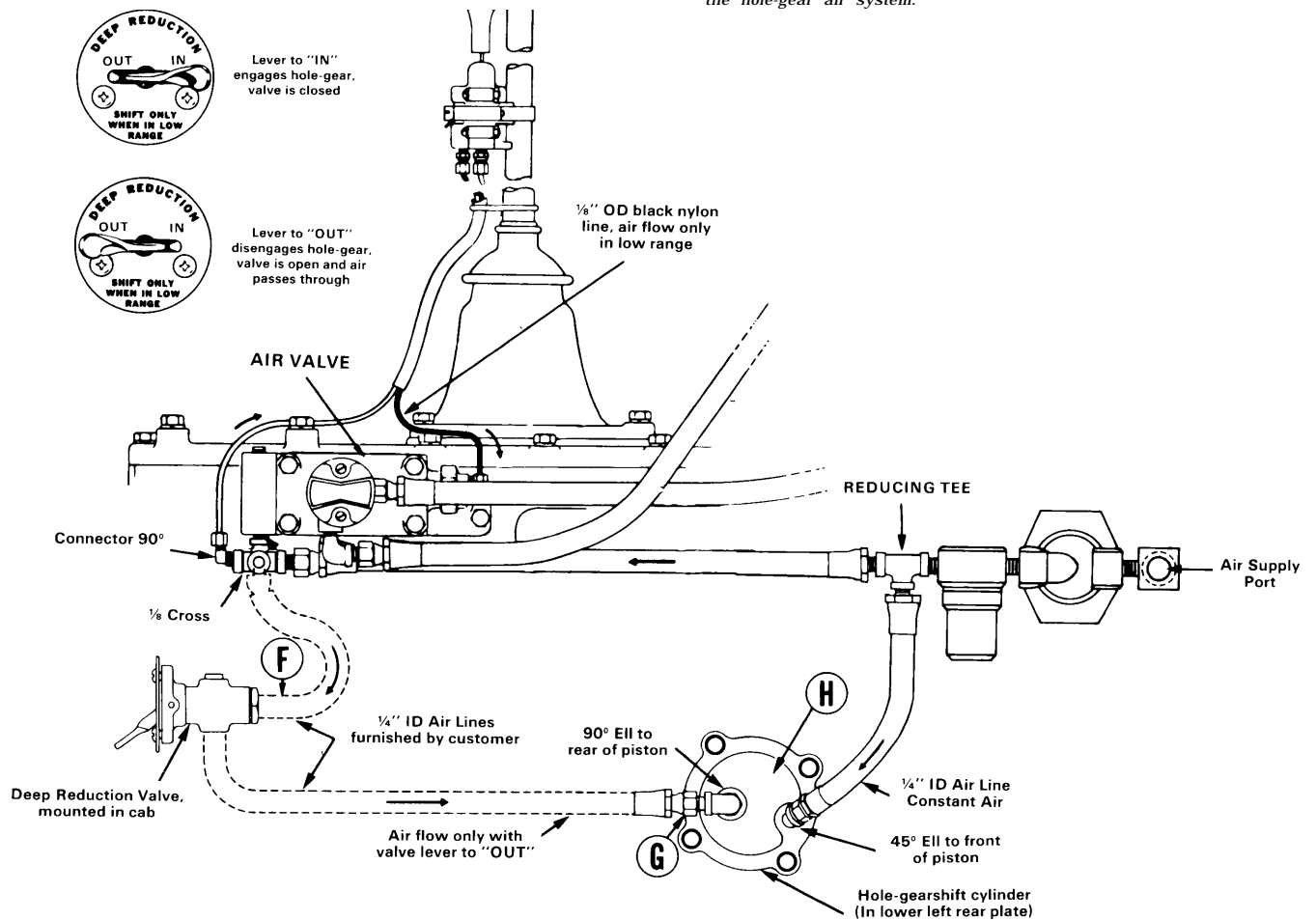

Air Valve Operation

With the range control button up the control valve shuts off the air supply to the end cap. Thus, the constant air entering at the constant supply port forces the piston to the rear. The constant air also flows through a channel in the center of the piston and to an external port which is aligned with the high range port of the air valve.

With the control button down the control valve opens and supplies air to the end cap. Since the piston area is larger on this end of the piston, it is forced in the opposite direction. The external air port in the piston is now aligned with the low range port of the air valve.

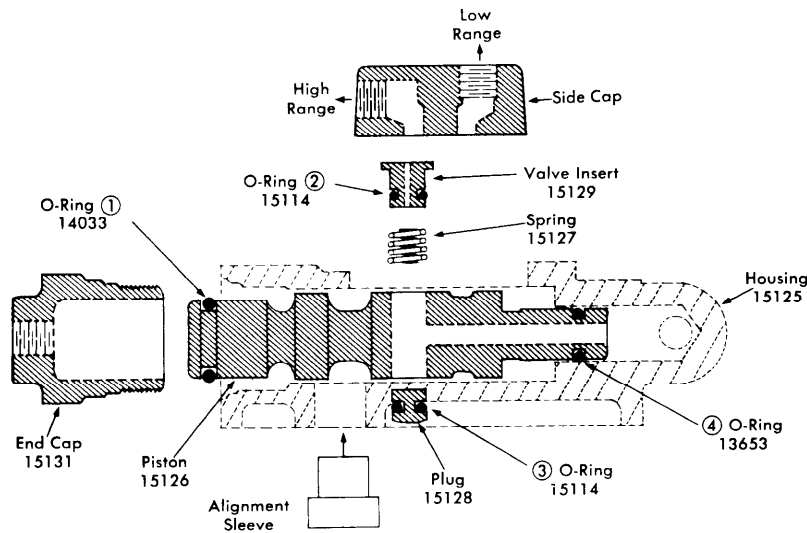

C. Exploded view of air valve. The alignment sleeve is not part of the assembly, but must be installed in housing for proper pre-select operation.

The four O-rings are indicated by circled numbers. If any of these are defective, there will be a constant air leak out of the exhaust on the air valve. In normal operation, exhaust will occur only for an instant as the range shift is made. The following chart is to be used as a guide to determine defective O-rings.

Defective O-Rings	RESULT
1	Constant leak through exhaust in low range only.
2 or 3	Constant leak through exhaust in both ranges.
4	Constant leak through exhaust in high range; steady but low volume leak through exhaust in low range.

To Disassemble Air Valve

1. Turn out the two capscrews and remove the side cap
2. Remove the valve insert from piston and remove O ring from the valve insert.
3. Remove the spring from piston.
4. Turn end cap from valve body and withdraw piston from bore.
5. Remove the two O-rings from piston.
6. Remove the nylon plug from piston and remove O-ring from plug.

Air Valve Pre-Selection

An actuating pin protruding from the shifting bar housing prevents the actuating piston in the air valve from moving while the gearshift lever is in a gear position and releases the

piston when the lever is moved to or through neutral. See detailed installation of air valve for installation precaution concerning the actuating pin.

SLEEVE

D, Cross-section of actuating pin and plunger assembly.

Air Regulator

The air regulator is not serviceable. If defective replace the air regulator unit. Reading at output of air regulator should be 57.5 to 62.5 psi.

Air Filter & Regulator Assembly

Air Filter

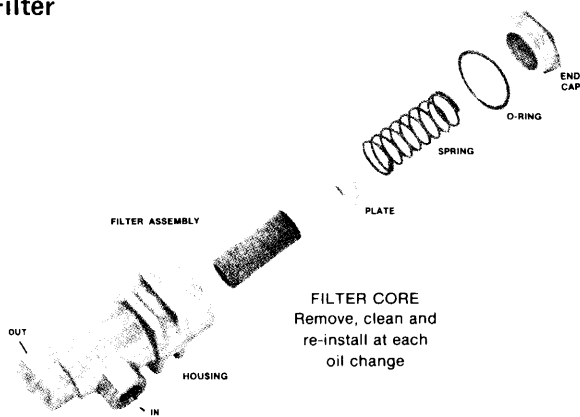

RT-12515 MODELS

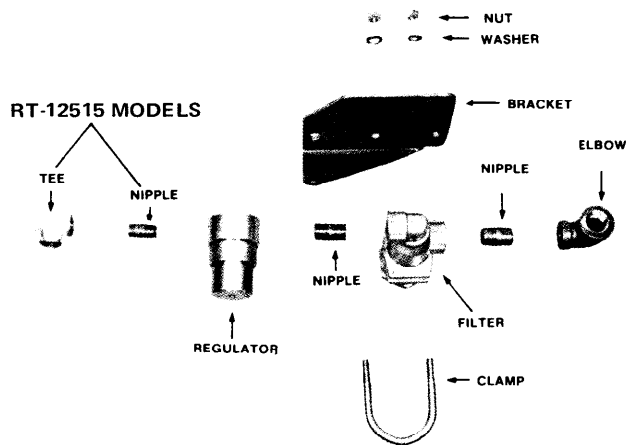

Control Valve Operation

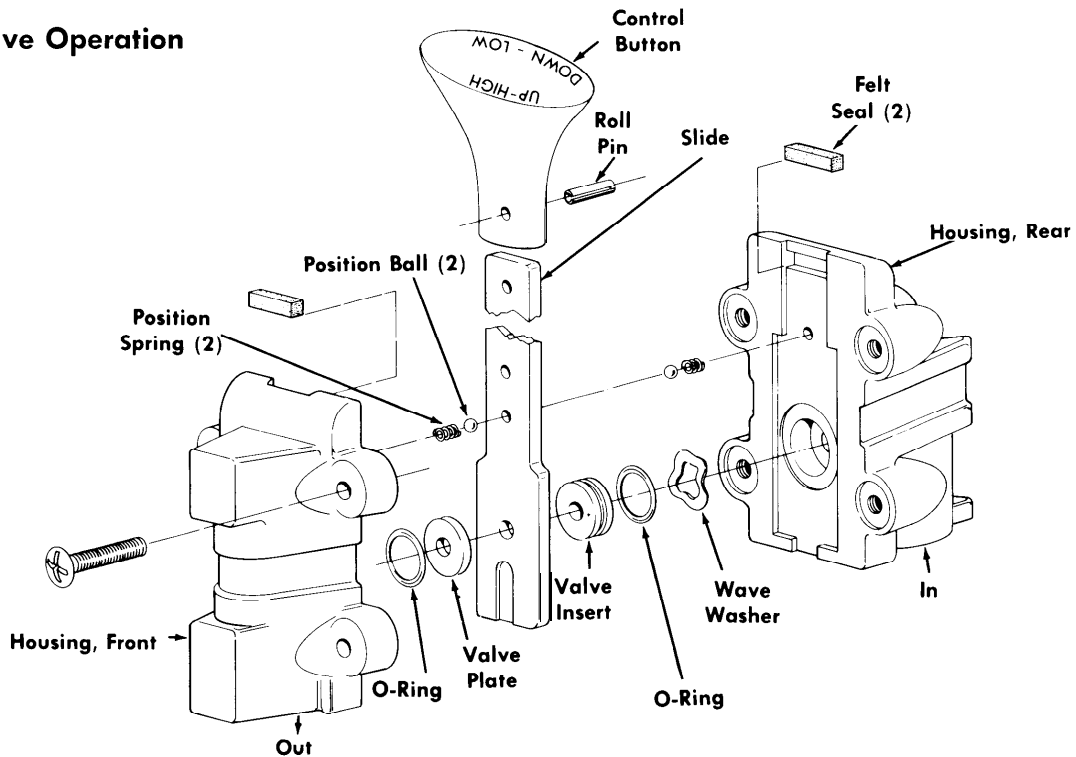

E. Exploded view of control valve. The "IN" port is constant supply. The "OUTLET" port is connected by 1/8" O. L. air line to end cap of air valve.

If the O-rings or parts in the control valve are defective there will be a constant air leak out the exhaust located on bottom of control valve.

A defective insert valve O-ring will result in a constant leak through exhaust in both ranges and valve will not make range shifts.

A defective housing O-ring will result in a constant, low volume leak through exhaust in low range only.

If the slide is assembled backwards, there will be a constant leak through exhaust in high range. When installing slide in control valve make sure that slot in slide faces the outlet part.

To Disassemble the Control Valve

1. Remove the four screws to separate front and rear housings.

2. Remove the slide and the two position balls and springs.
3. Remove the flat metal seal from outlet side and remove the O-ring from body.
4. Remove the valve insert from front housing and remove the O-ring from valve insert.
5. Remove the wave washer installed under valve insert.
6. Remove the two felt wipers from valve housings.
7. Punch out roll pin and remove control button from slide.

Air Valve O-Ring sizes, Ill. C			
Qty.	Location	ID	Width
2	Valve Insert and Plug	.208	.070
1	Piston	.549	.103
1	Piston	.364	.070
Control Valve O-Ring sizes, Ill. E			
1	Valve Insert	.301	.070
1	Housing	.375	.062

Trouble Shooting

Range Shift Air System All Models

The following checks are to be made with normal vehicle air pressure but with the engine off. Refer to Illustration A for check points.

1. Incorrect Hook-Up

With normal vehicle air pressure and gearshift lever in the neutral position, move the control button up and down, from one range to another.

- a. If lines are crossed between the control valve and the air valve on transmission, there will be a steady flow of air from the top exhaust in control valve if button is held in the up position.
- b. If lines are crossed between the air valve on transmission and the air or shift cylinder, the transmission gearing will not correspond with the button position. Low range, down position of button, will result in high range gear engagement in the transmission and vice versa.

2. Air Leaks

With normal vehicle air pressure and gearshift lever in the neutral position, coat all air lines and fittings with soapy water and check for leaks, moving control button to both positions.

- a. If there is a steady leak out exhaust of control valve, there are defective parts or O-rings in the control valve.
- b. If there is a steady leak out breather on air valve; there is a defective O-ring in the air valve; or there is a leak past O-rings on the shift cylinder piston (see Ill. F, Check Point E).
- c. If transmission fails to shift into low range or is slow to make the shift and the transmission case is pressurized, see Ill. F, Check Point E.
- d. Tighten all loose connections and replace defective parts or O-rings.

3. Air Regulator, Check Point A

With normal line pressure and gearshift lever in neutral, check exhaust port on side of air regulator. There should be no leak from this port.

If there is a steady leak from exhaust port, this indicates a defective air regulator and should be replaced.

Cut off the vehicle air pressure and install air gauge in line at output port of air regulator. Bring vehicle air pressure to normal. Regulated pressure should be 57.5 to 62.5 psi.

If correct pressure readings are not obtained, replace regulator.

4. Control Valve, Check Point B

With the gearshift lever in neutral, pull the control button up to high range and disconnect the 1/8" black nylon air line at air valve.

- a. When control button is pushed down a steady blast of air should flow from the disconnected line. Air will shut off when button is pulled up. This indicates that control valve is operating correctly. Reconnect air line. If control valve does not operate correctly, check for leaks, restrictions and defective O-rings.

5. High Range, Check Point C

With the gearshift lever in neutral, push the control button down and disconnect the high range air line from the shift cylinder cover.

- a. Pull the control button up. There should be a steady flow of air from the high range air line. Push button down to shut off air.
- b. Make sure vehicle engine is off and move the gearshift lever to a gear position. Pull the button up; there should be no air at high range line. Move the gearshift lever to neutral; there should now be a steady flow of air from the high range line. Push button down to shut off air and reconnect line.
- c. If air system operated incorrectly, this indicates that air valve is defective or that actuating parts in shifting bar housing are jammed or defective.

6. Low Range, Check Point D

With the gearshift lever in neutral, pull the control button up and disconnect the low range air line at shift cylinder.

- a. Repeat procedure under Check Point C, reversing the position of the control button in order to check the low range operation.

7. Range Shift Cylinder – Check Point E

If any of the seals in the range shift cylinder are defective the range shift will be affected. The degree of lost air, of course, will govern the degree of failure, from slow shift to complete failure to shift.

Refer to Illustration F for location of seals. Make sure cylinder bore is clean to prevent damage to piston seal. Use only a very light amount of shellac or Permatex on cover gasket to prevent clogging cylinder. Tighten cover capscrews securely.

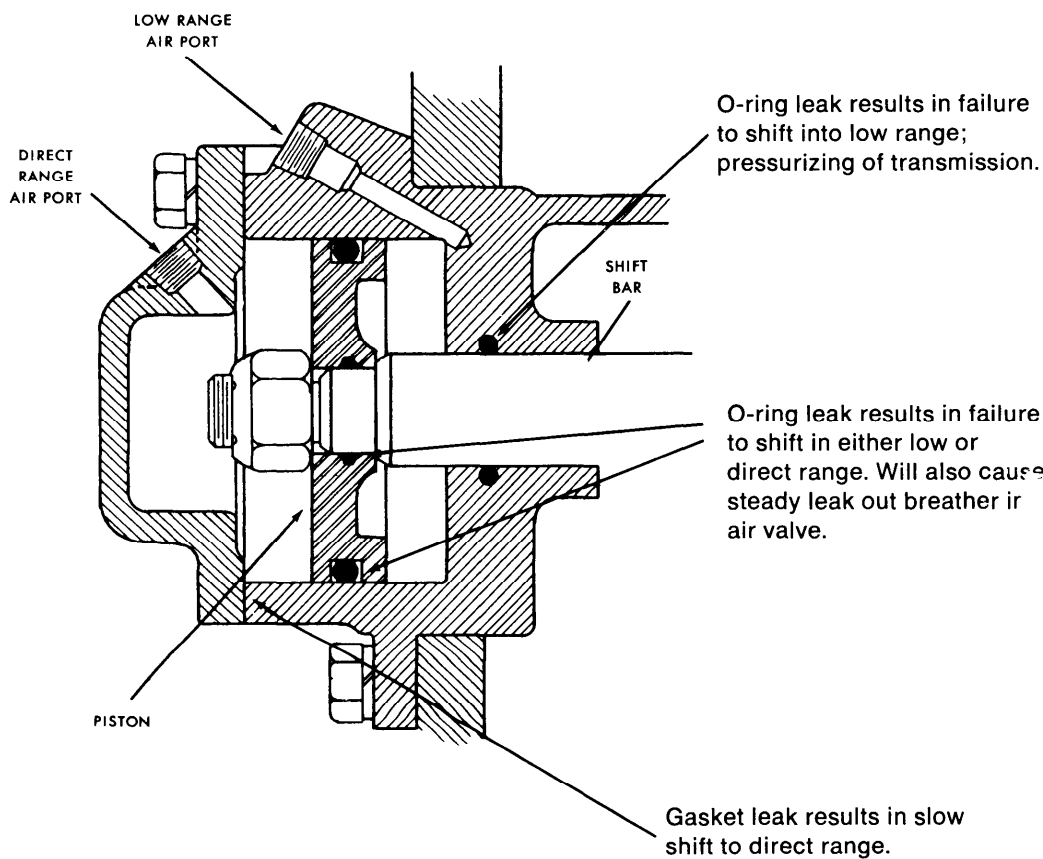

F. Range Shift Cylinder – All Models

Hole-Gear Air System RT-12515 and RTO-12515 Transmissions

The following checks are to be made with normal vehicle air pressure but with the engine off. It is assumed air lines have been checked for leaks and the air regulator has been checked and the correct reading obtained. Refer to Illustration B for check points.

1. Air Input – Check Point F

With gearshift lever in neutral and normal vehicle air pressure, loosen the connection at input (end port) of the deep reduction valve until it can be determined that there is a constant flow of air at this point. Reconnect line.

If there is no air at this point, there is a restriction in the line between the deep reduction valve and air valve. Also check to make sure this line is connected to constant supply.

2. Deep Reduction Valve – Check Point G

With the deep reduction valve lever to “IN”, remove the line from the deep reduction valve at the port in hole-gearshift cylinder; there should be no air at this point.

Move the deep reduction valve lever to “OUT”. There should now be a constant air flow from line. Move lever to “IN” to shut off air. If the above conditions do not exist, deep reduction valve is faulty or there is a restriction in air line.

3. Hole-Gearshift Cylinder – Check Point H

If any of the seals in the hole-gearshift cylinder are defective the hole-gearshift will be affected. The degree of lost air, of course, will govern the degree of failure, from slow shift to complete failure to shift.

Refer to Illustration G, for location of seals

Leak at seal A Failure to engage hole-gear; pressurizing of transmission; hole-gear can be disengaged.

Leak at seal B... Failure to engage hole-gear; leak from deep reduction valve exhaust port when valve is “IN”.

G. Cutaway. Deep Reduction Shift Cylinder. (R T-12515 models)

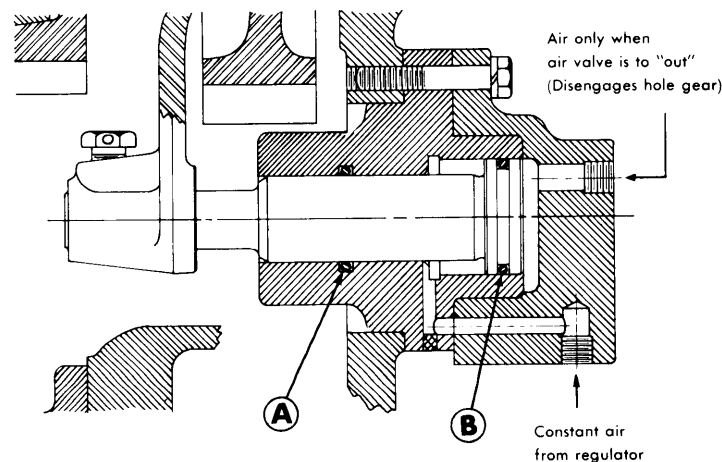

Preventive Maintenance Check Chart

CHECKS WITHOUT PARTIAL DISASSEMBLY OF CHASSIS OR CAB

- 1. Air System and Connections**
 - a. Check for leaks, worn air lines, loose connections and capscrews. See Air Systems.
- 2. Clutch Housing Mounting**
 - a. Check all capscrews in bolt circle of clutch housing for looseness. Tighten to recommended torque.
- 3. Clutch Release Bearing**
 - a. Remove hand hole cover and check radial and axial clearance in release bearing.
 - b. Check relative position of thrust surface of release bearing with thrust sleeve on push type clutches.
- 4. Clutch Pedal Shaft and Bores**
 - a. Pry upward on shafts to check wear.
 - b. If excessive movement is found, remove clutch release mechanism and check bushings in bores and wear on shafts.
- 5. Gear Lubricant**
 - a. Change at specified service intervals.
 - b. Use only gear oils as recommended. See Lubrication section.
- 6. Filler and Drain Plugs**
 - a. Remove filler plug and check level of lubricant at specified intervals. Tighten filler and drain plugs securely.
- 7. Gear Shift Lever**
 - a. Check for looseness and free play in housing. If lever is loose in housing, proceed with Check No. 8.

8. Gearshift Lever Housing Assembly

- a. Remove air lines at air valve and remove the gearshift lever housing assembly from transmission.
- b. Check tension spring and washer for set and wear.
- c. Check the gearshift lever pivot pin and pivot pin slot for wear.
- d. Check bottom end of gearshift lever for wear and check slot of yokes and blocks in shift bar housing for wear at contact points with shift lever.

CHECKS WITH DRIVE LINE DROPPED

9. Universal Joint Companion Flange Nut

- a. Check for tightness. Tighten to recommended torque.

CHECKS WITH UNIVERSAL JOINT COMPANION FLANGE REMOVED

10. Splines on Output Shaft

- a. Check for wear from movement and chucking action of the universal joint companion flange.

11. Mainshaft Rear Bearing Cover

- a. Check oil seal for wear.

12. Output Shaft

- a. Pry upward against output shaft to check radial clearance in mainshaft rear bearing.

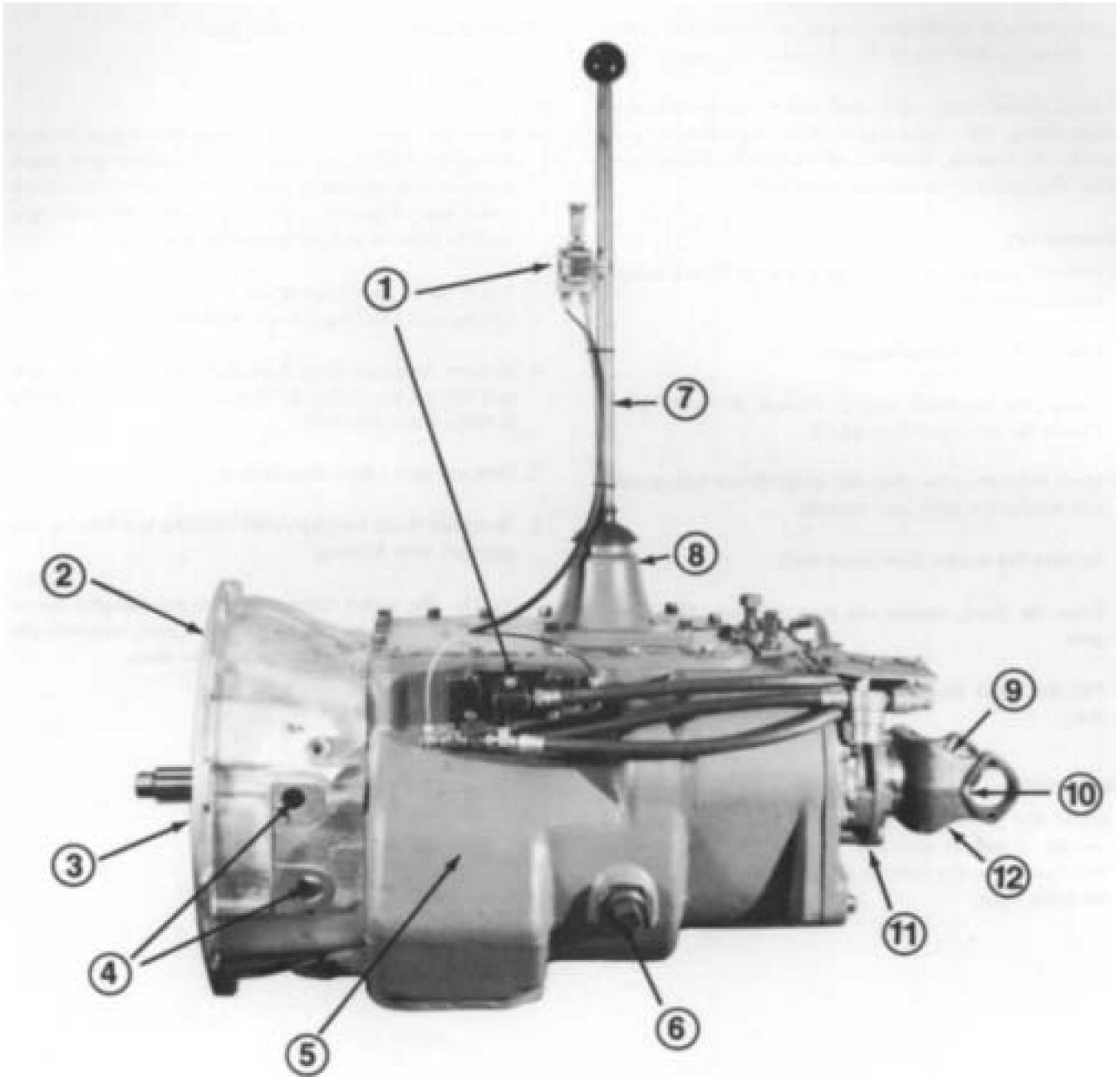

Special Procedure For Changing Clutch (Input) Shaft

In some cases in field repair it may be necessary to replace only the input shaft due to clutch wear on the splines.

In these instances the input shaft can be removed without disassembling the transmission other than removing the shifting bar housing. Removal of the clutch housing is optional. Following is the detailed procedure:

Disassembly

1. Remove gearshift lever housing and shift bar housing from transmission.
2. Remove the front bearing cover.
3. Engage the mainshaft sliding clutches in two gears and remove the drive gear bearing nut.
4. Move the drive gear assembly as far forward as possible and remove the drive gear bearing.
5. Remove the washer from input shaft.
6. From the front, remove the snap ring from ID of drive gear.
7. Pull the input shaft forward and from splines of drive gear.
2. Install snap ring in ID of drive gear.
3. Install washer on shaft.
4. Move the fourth-fifth speed sliding clutch gear forward to contact end of input shaft in hub of drive gear. Block between rear of sliding clutch and front of the fourth speed gear. When installing bearing this will hold input shaft in position to seat the bearing properly.
5. Install drive gear bearing on shaft and into case bore, making sure blocking remains in place.
6. Remove blocking from mainshaft and install the drive gear bearing nut, left-hand thread. Use Loctite sealant on threads of nut and shaft.
7. Peen nut into milled slots in shaft.
8. Re-install front bearing cover, shifting bar housing and gearshift lever housing.

NOTE: 7%e above instructions are for changing the input shaft only. To change the drive gear, complete disassembly of the front section must be made.

Reassembly

1. Install new input shaft into splines of drive gear just far enough to expose snap ring groove in ID of drive gear. Make sure that the bushing is installed in the pocket of the input shaft.

General Precautions for Disassembly

IMPORTANT: Read this section before starting the detailed disassembly procedures.

[It is assumed in the detailed disassembly instructions that the lubricant has been drained from the transmission, the necessary linkage and air lines removed and the transmission has been removed from the chassis. Removal of the gearshift lever housing assembly is included in the detailed instructions; however, this assembly must also be removed from transmission before removing unit from vehicle.

On RT-12515 and RTO-12515 models, air lines from the hole-gear switch in cab must be disconnected at the transmission before removing unit from vehicle.

Follow each procedure closely in each section, making use of both the text and pictures.

1. **BEARINGS** Carefully wash and relubricate all bearings as removed and protectively wrap until ready for use. Remove all bearings with pullers designed for this purpose -- do not remove bearings with hammer and punch.

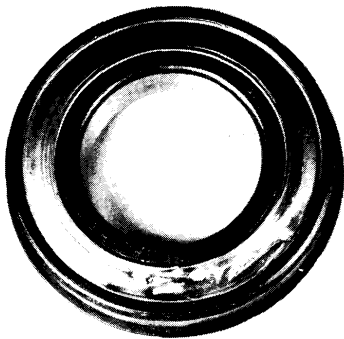

BEARING
REMOVED WITH
PUNCH, DAMAGED
SHIELD.

BEARING
REMOVED WITH
CHISEL, DAMAGED
OUTER RACE.

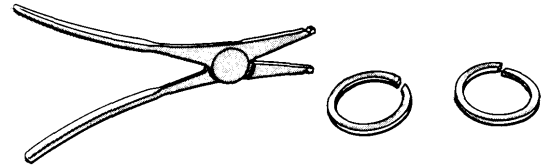
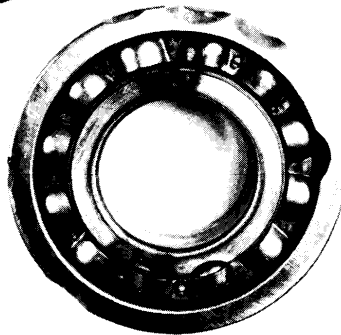

2. **SNAP RINGS** Remove snap rings with pliers designed for this purpose. Rings removed in this manner can be reused.
3. **INPUT SHAFT** The clutch or input shaft can be removed on most models without removing the countershaft, mainshaft or drive gear. See page 26.
4. **CLEANLINESS** Provide a clean place to work. It is important that no dirt or foreign material enters the unit during repairs. The outside of the unit should be carefully cleaned before starting the disassembly. Dirt is abrasive and can damage highly polished parts such as bearings, sleeves and bushings.
5. **WHEN DRIVING** Apply force to shafts, housings, etc., with restraint. Movement of some parts is restricted. Do not apply force after the part being driven stops solidly. Use soft hammers and bars for all disassembly work.

1. Shifting Controls.

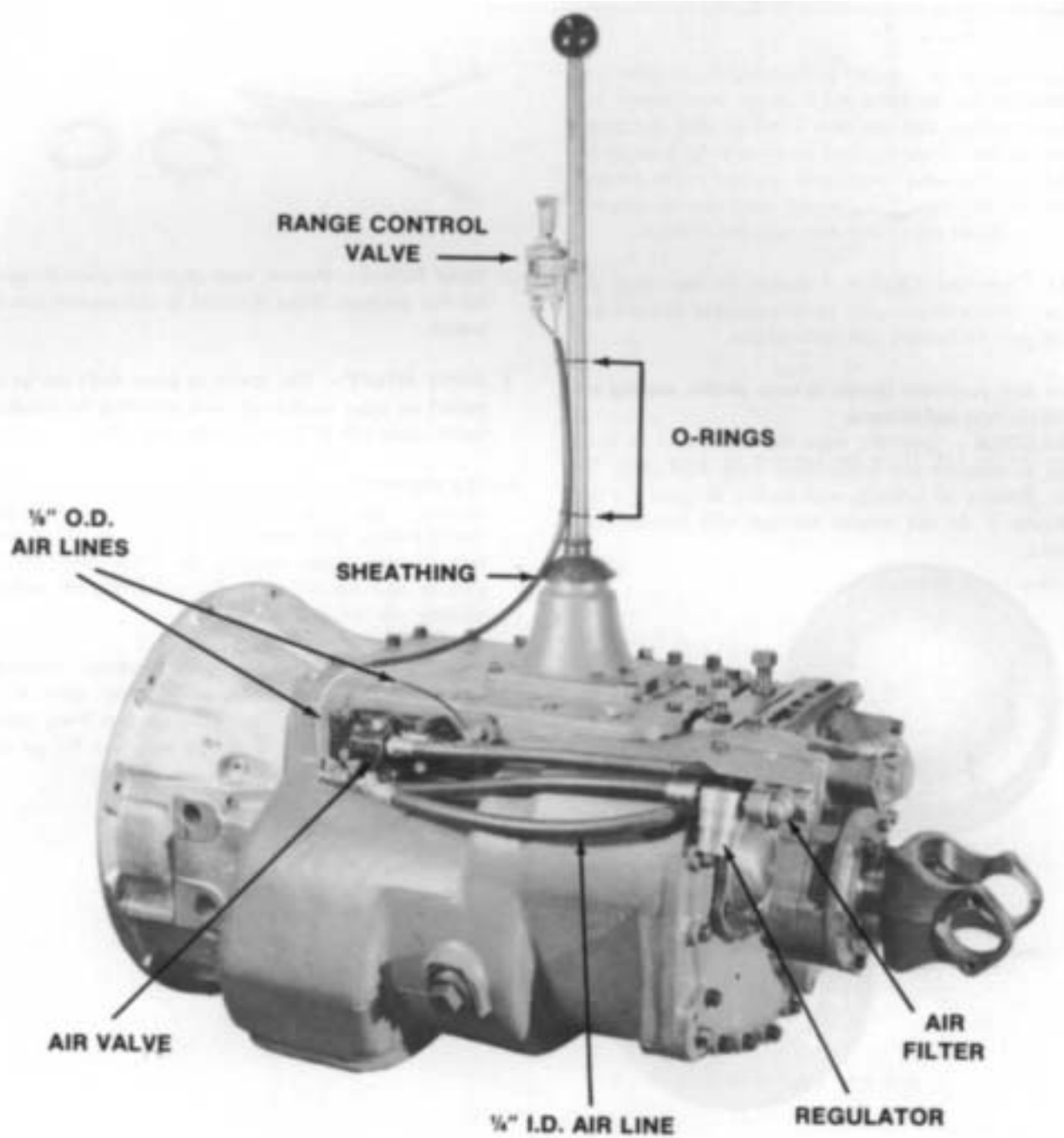

A. Removal of the Deep Reduction Shift Air System D RT-12515 Series

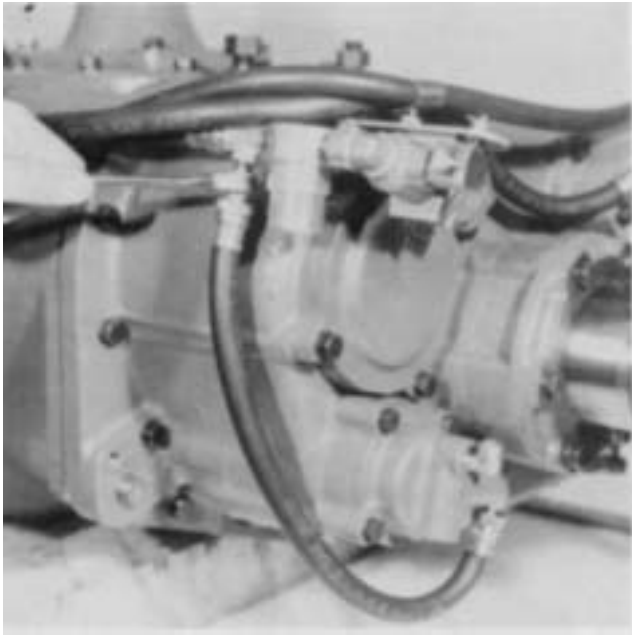

1. Remove the 1/4" ID air line between the deep reduction shift cylinder and the tee fitting forward of the filter / regulator assembly.

B. Removal of the Range Shift Air System

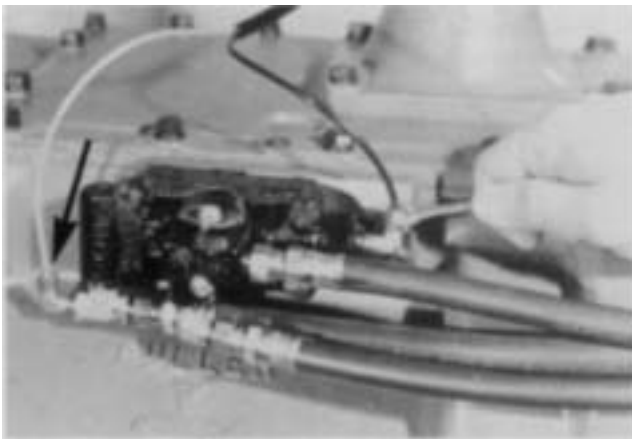

1. Disconnect the black and white 1/8" OD air line at the air valve on the side of the transmission.

NOTE: The gear shift lever housing, range control valve and lines may now be removed as a unit by turning out the four capscrews at the base of the gear shift lever housing.

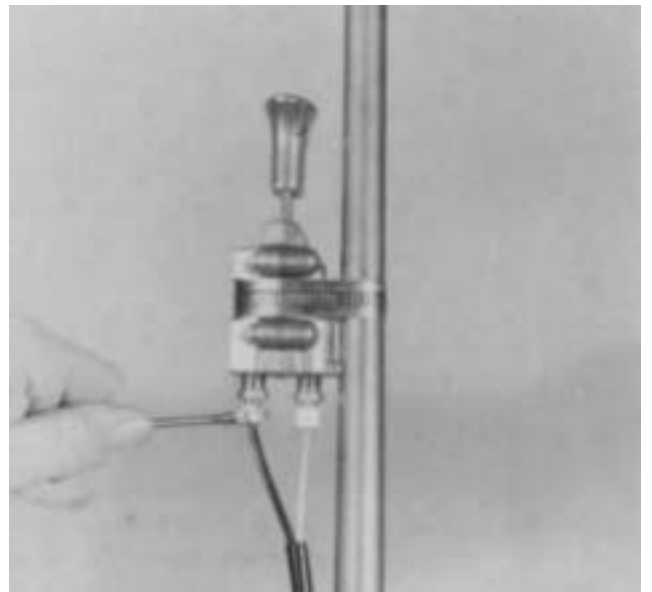

2. Disconnect the black and white 1/8" O D air line at the range control valve on the shift lever.

B. Removal of the Range Shift Air System - continued

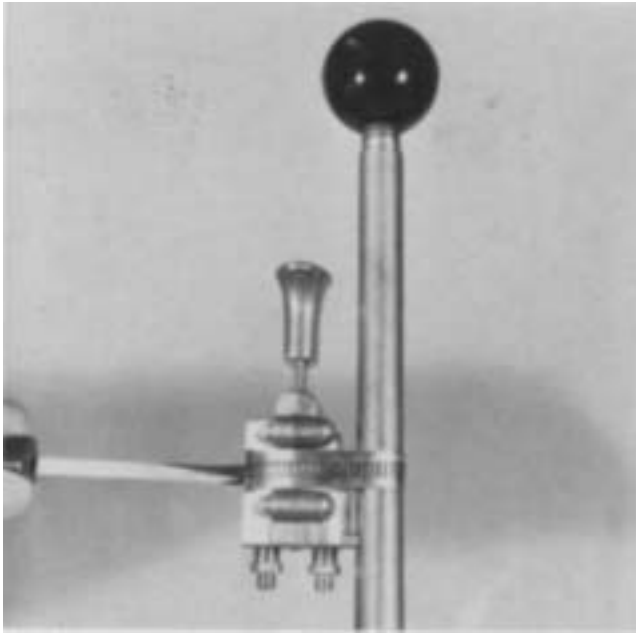

Loosen the clamp holding the range control valve to the lever.

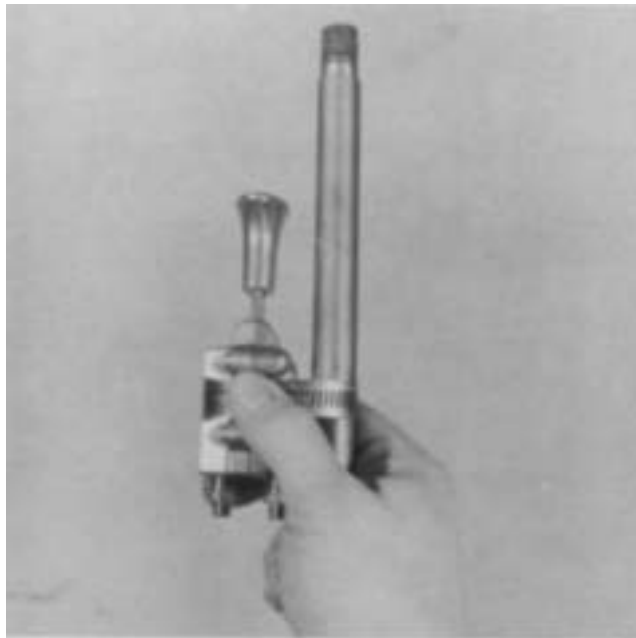

Turn the shift ball from the top of the lever and remove the valve, air lines, sheathing and o-rings. For further disassembly of the range control valve, refer to page 20.

NOTE: For ease of reassembly, it is advisable to tag the 1/4" I.D. air lines as to their proper locations during removal.



5. Remove the hose clamp and disconnect the two 1/4" ID air lines between the air valve and the range shift cylinder.

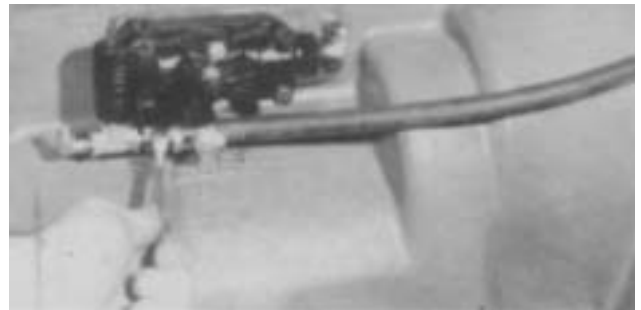

6. Disconnect the 1/4" ID air line between the air valve and the filter/regulator assembly.

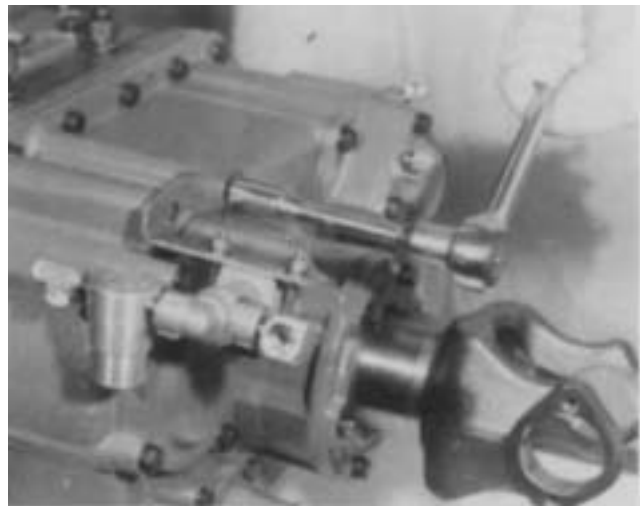

7. Remove the filter/regulator assembly from the auxiliary housing. For further disassembly, refer to page 19.



8. Turn out the four cap screws and remove the air valve from the side of the front case. For further disassembly of the air valve, refer to page 18.



10. Remove the spring and plunger from the bore in the adaptor plate.



Remove the alignment sleeve from the air valve or the bore in the adaptor plate.



11. Turn out the two cap screws and two Allen head screws and remove the adaptor plate from the side of the case.

Disassembly — Gearshift Lever Housing

C. Removal and Disassembly of the Gear Shift Lever Housing

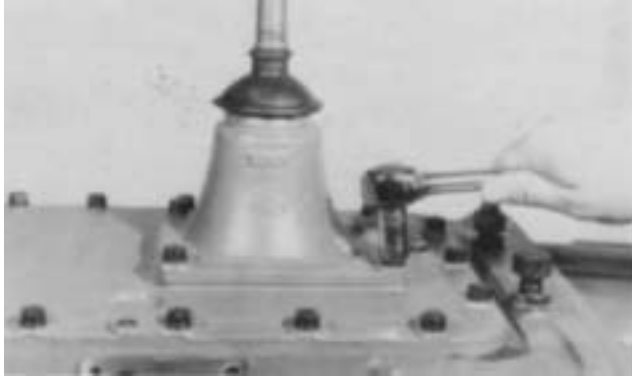

1. Turn out the four capscrews, jar lightly to break the gasket seal and lift the gear shift lever assembly from the shift bar housing.

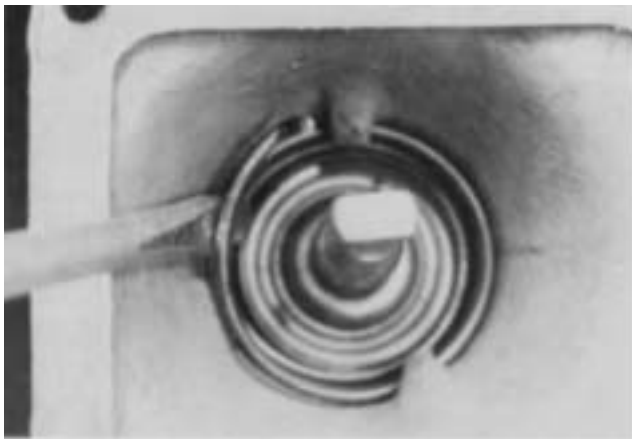

2. Remove the rubber dust cover from the lever and mount the assembly in a vise by the housing. Free the tension spring from the housing by inserting a large, heavy-bladed screwdriver between the spring and the housing and twisting. Force the spring from under the lugs in the housing one coil at a time.



3. Remove the tension spring washer and lever from the housing.

4. Turn out the nut and remove the pivot pin from the housing.



5. Remove the O-ring from the groove in the top of the housing.

D. Removal and Disassembly of the Shift Bar Housing Assembly



- 1 Turn out the retaining capscrews, jar to break the gasket seal and lift the shift bar housing from the case.

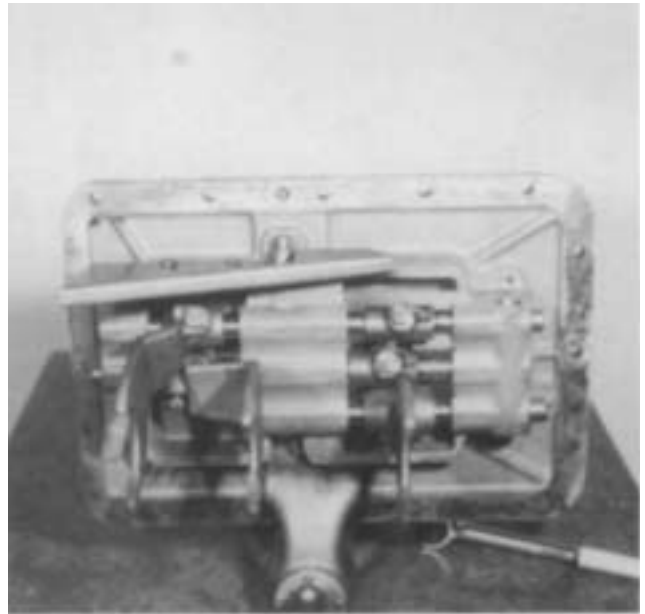

3. Mount the housing on its side in a vise with the exposed end of the actuating plunger facing up.

NOTE: Lay all parts on a clean bench in the order of removal to facilitate reassembly. Bars not being removed must be kept in the neutral position or interlock parts will lock the bars, preventing removal.



2. Remove the three tension springs and tip the housing to remove the three tension balls located under the springs. If necessary, remove the reverse light pin and plug from the housing.

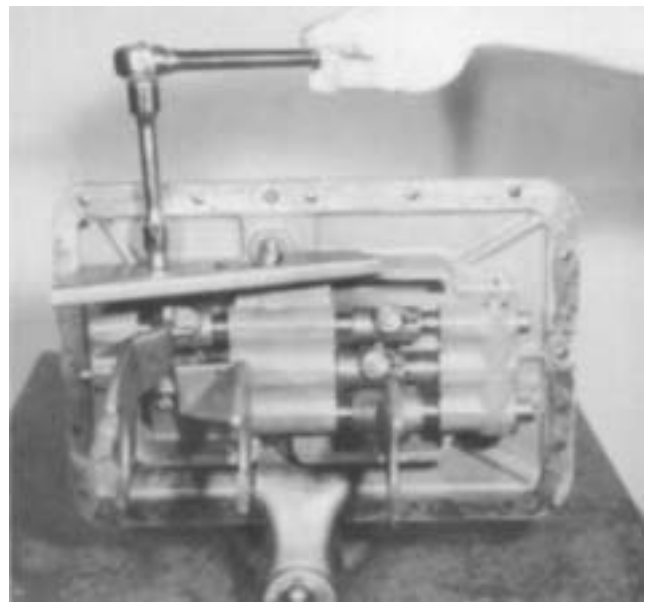

4. Cut the lockwire, turn out the lockscrews and remove the oil trough from the side of the shift bar housing. (Oil trough is optional)

Disassembly — Shift Bar Housing

D. Disassembly of the Shift Bar Housing - continued

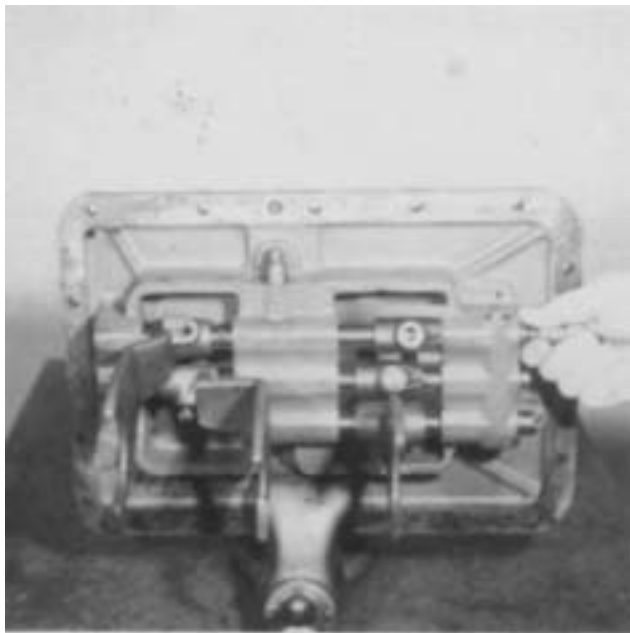

5. Cut the lockwires, turn out the lockscrews and remove the 4th-5th speed shift bar, block and yoke from the housing.

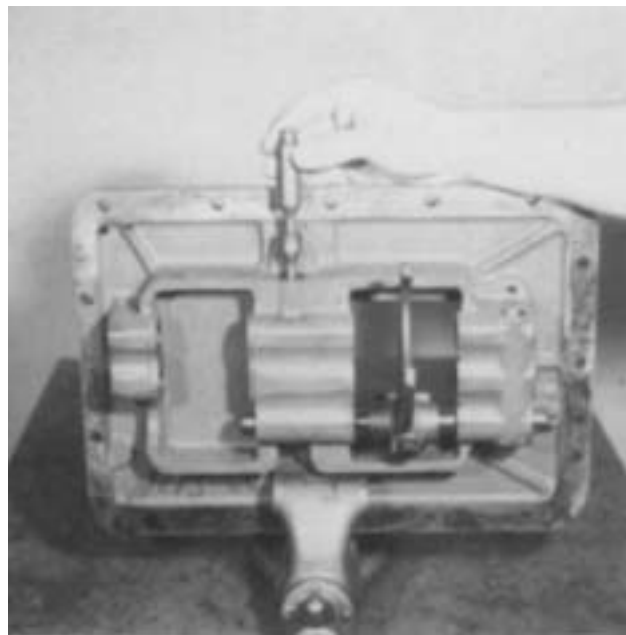

7. Remove the actuating plunger from the bore in the housing.

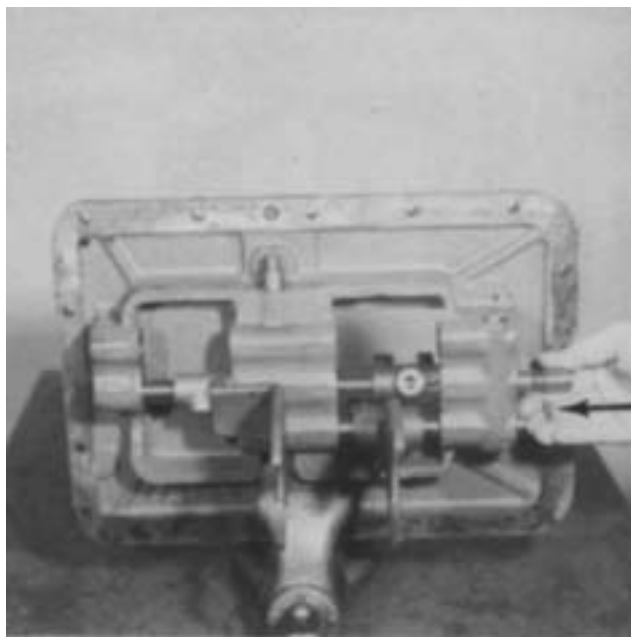

6. Cut the lockwires, turn out the lockscrews and remove the 2nd-3rd speed shift bar, block and yoke from the housing. As the neutral notch clears the housing boss, remove the interlock pin from the notch.

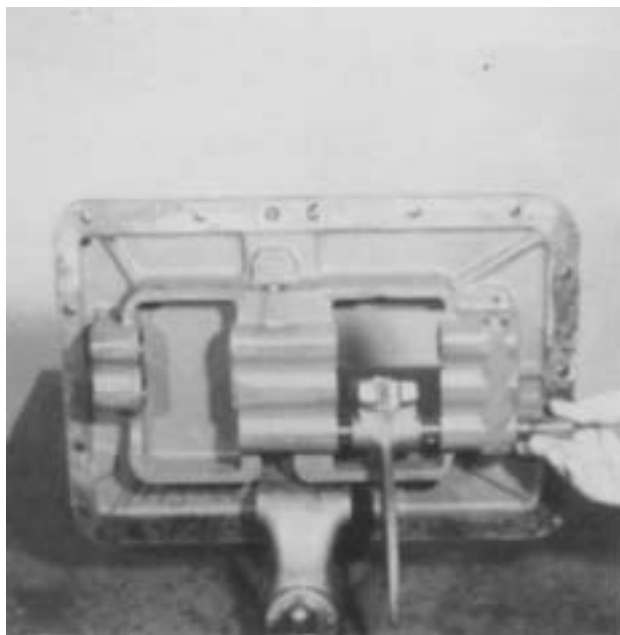

8. Cut the lockwire, turn out the lockscrew and remove the 1st-reverse speed shift bar and yoke.

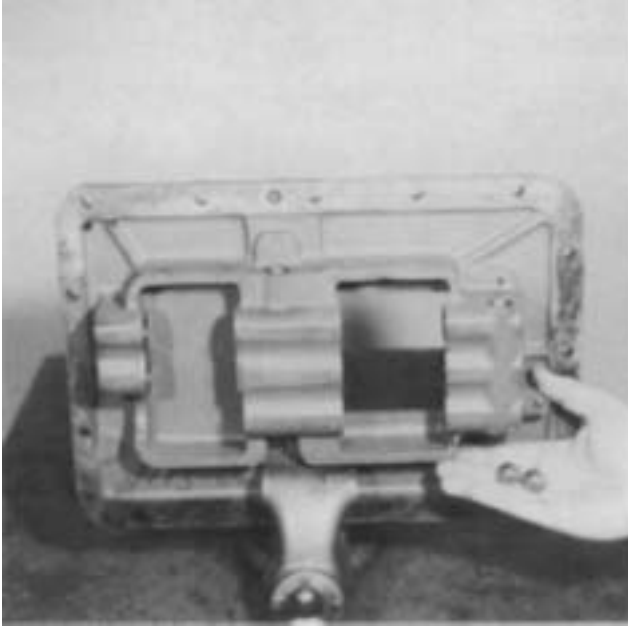

9. Remove the two interlock balls from the bore in the housing boss.

II. Companion Flange, Auxiliary Housing and Clutch Housing

A. Removal of the Companion Flange or Yoke



1. Use a large breaker bar to remove the stop nut from the output shaft.



2. Remove the stop nut washer and companion flange or yoke from the splines of the output shaft.

B. Removal of the Auxiliary Housing

NOTE: The RT-12515 auxiliary housing is shown in the following steps, but the procedure is the same for the RT-12510 and RT-1110 series transmissions.

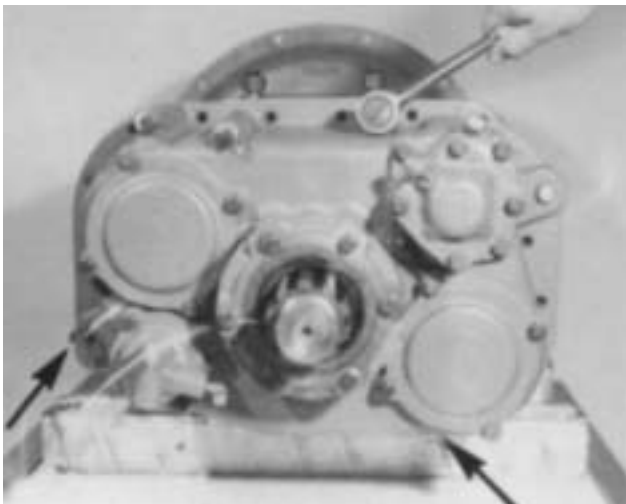

1. Turn out the capscrews and insert three puller screws in the three tapped holes in the auxiliary housing flange. Tighten the puller screws evenly to move the housing approximately 1/2" to the rear.

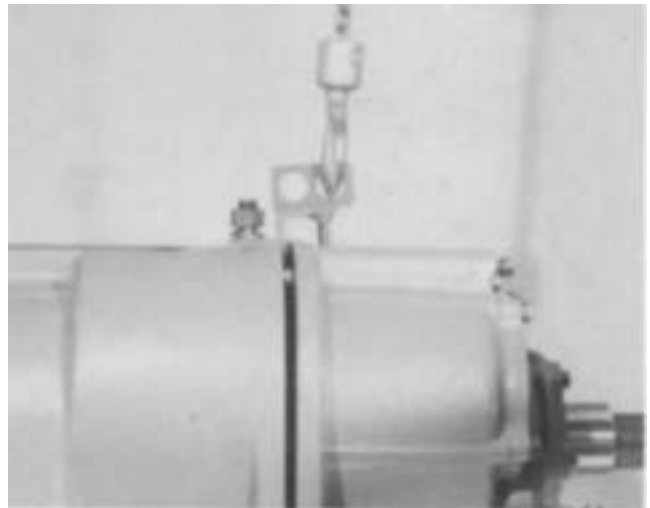

2. Attach a chain hoist to the auxiliary housing and move the housing to the rear and off the front case dowel pins.



3. The transmission can also be set vertically to remove the auxiliary housing. Block under the clutch housing to prevent damage to the input shaft and lift the auxiliary housing upwards and from the front case.

C. Removal of the Clutch Housing

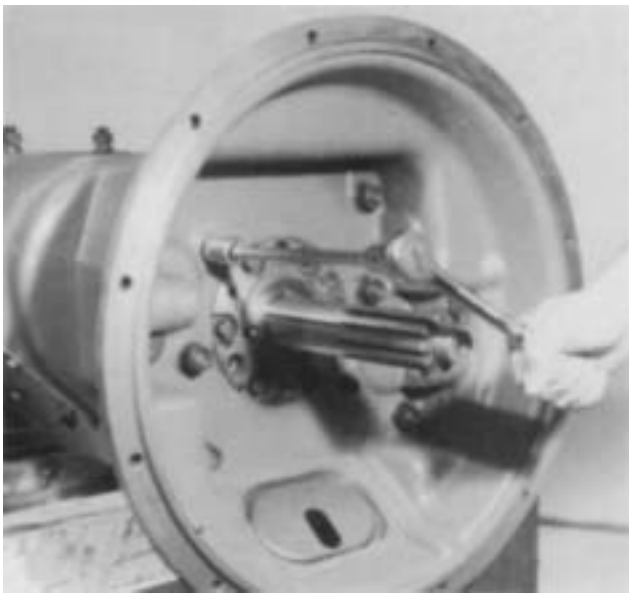

1. If so equipped, remove the clutch release mechanism and/or upshift clutch brake and turn out nuts and bolts securing the clutch housing to the front case.

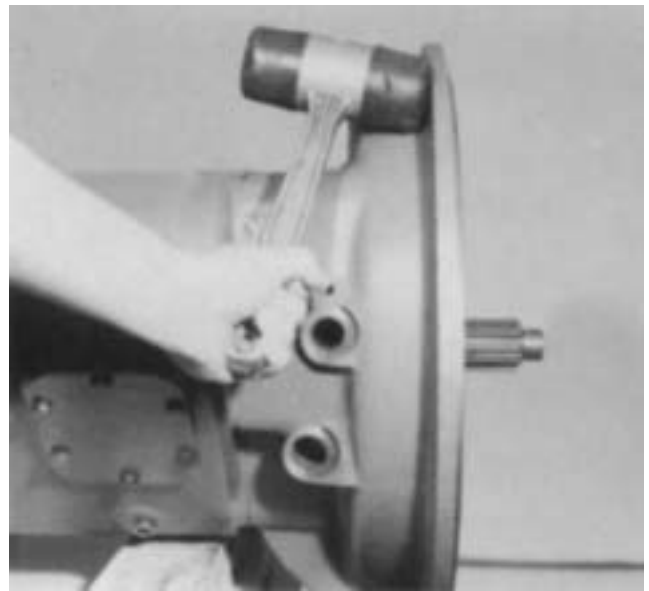

2. Jar the clutch housing with a rubber mallet to break the gasket seal and pull the housing straight forward and off the studs and front bearing cover.

III Front Section

A. Removal and Disassembly of the Auxiliary Drive Gear Assembly

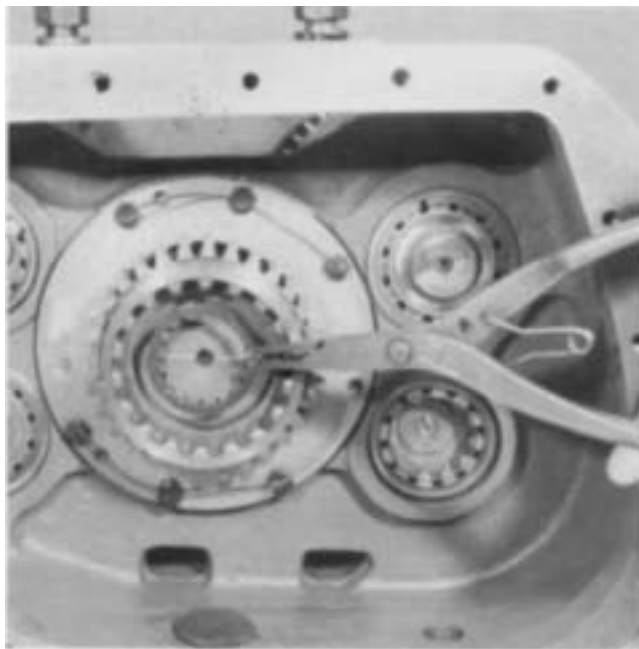

1. Remove the mainshaft rear snap ring from the shaft.

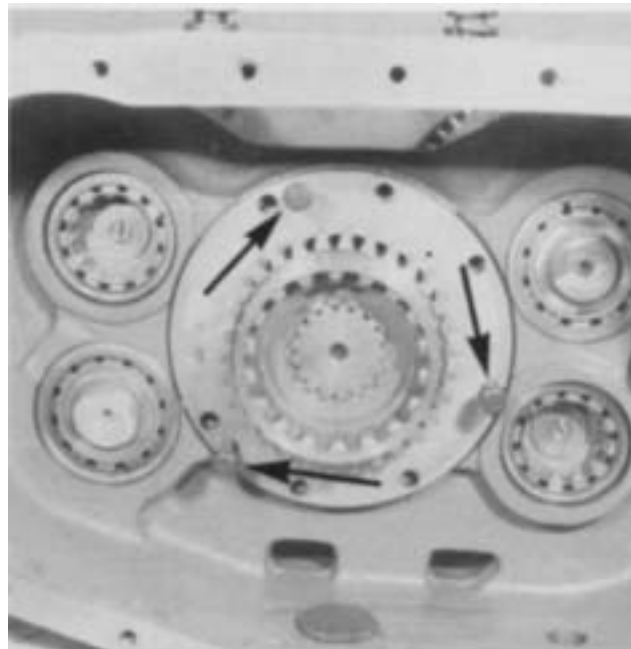

3. Insert three puller screws in the tapped holes of the retainer ring and tighten evenly to remove the drive gear assembly from the case bore.

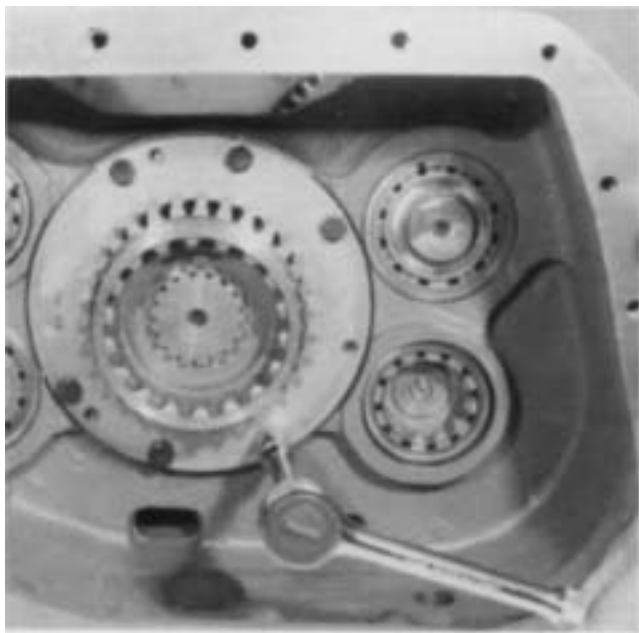

2. Cut the lockwires and remove the lockscrews from the bearing retainer ring.

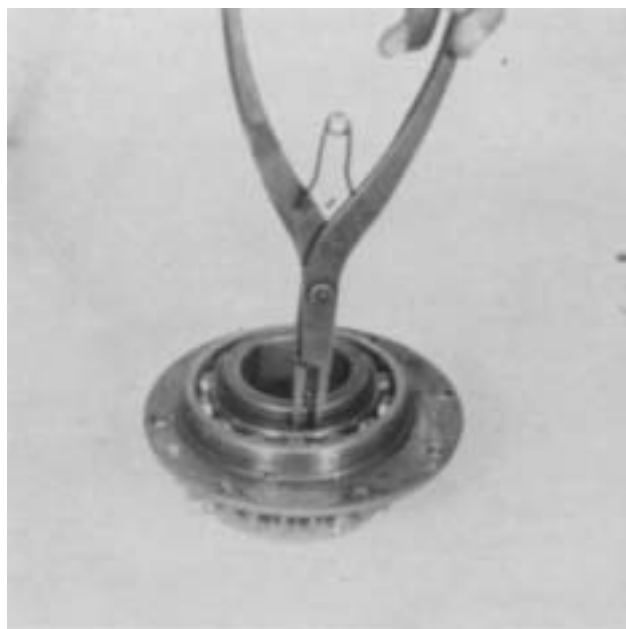

4. Remove the snap ring from the hub of the auxiliary drive gear and press the retainer ring and bearing from the gear.

B. Removal and Disassembly of the Left Reverse Idler Gear Assembly



1. Move the mainshaft reverse gear as far to the rear as possible and remove the snap ring from the ID of the gear.

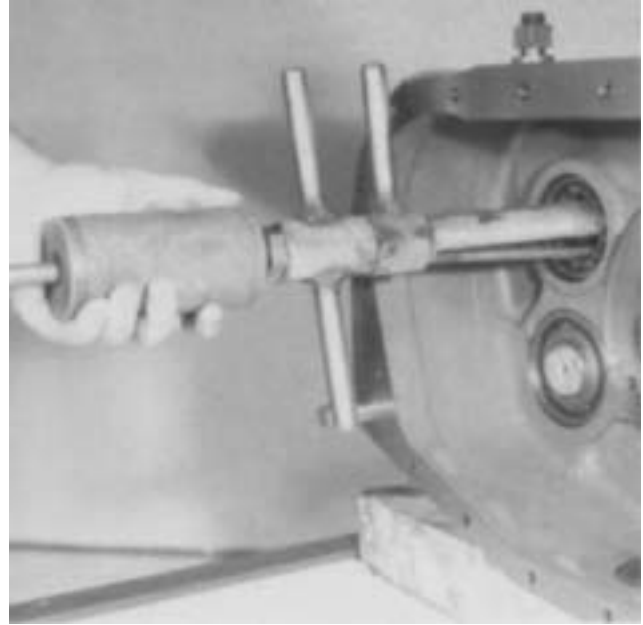

3. Use inside jaw pullers to remove the left auxiliary countershaft front bearing from the reverse idler bore. The right auxiliary countershaft front bearing may also be removed at this time.



2. Move the reverse gear forward and against the speed gear, engaging the splines of the sliding clutch.

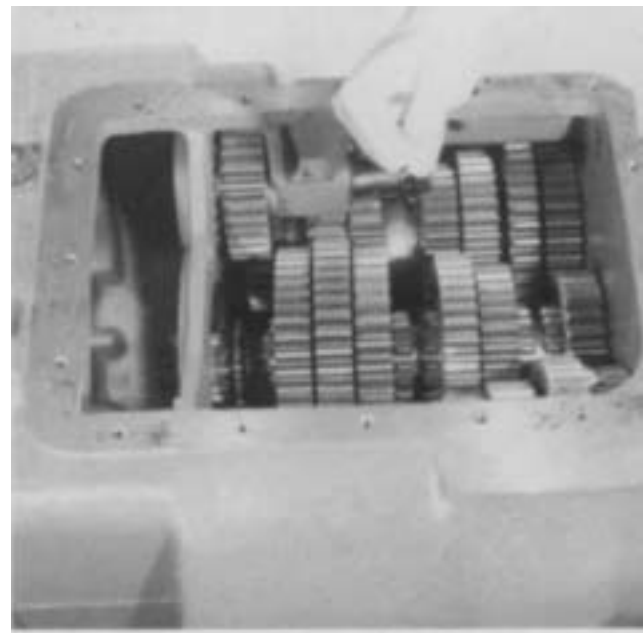

4. Remove the elastic stop nut and washer from the front of the idler shaft.

Disassembly — Front Section

B. Disassembly of the Left Reverse Idler Gear Assembly - continued

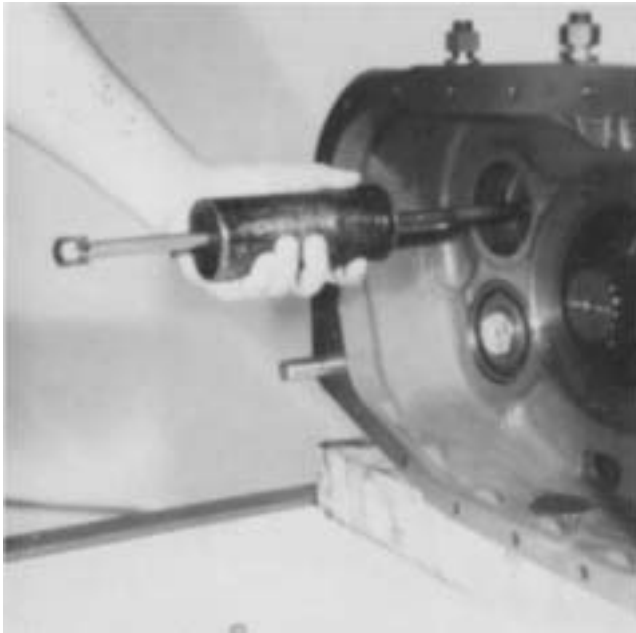

5. Remove the plug from the bore in the rear of the idler shaft, insert an impact puller in the bore and remove the shaft.



7. If necessary, remove the bearing inner race and rear washer from the idler shaft.

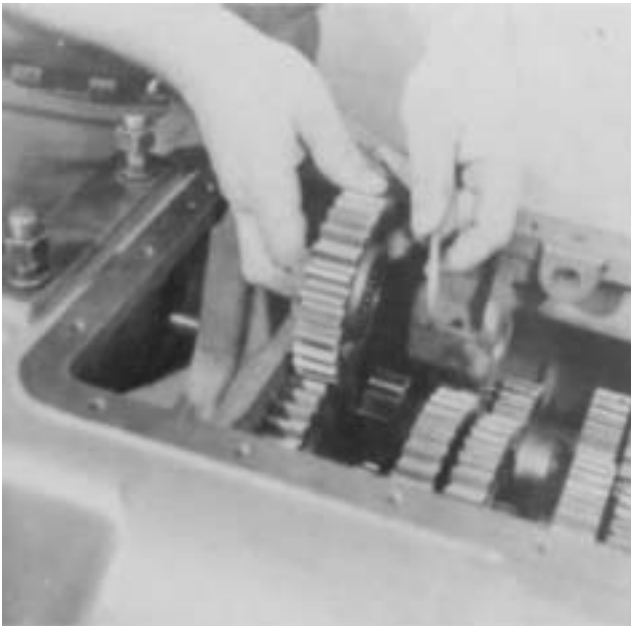

6. As the shaft is moved to the rear, remove the gear and thrust washer from the case.

C. Removal of the Countershaft Bearings

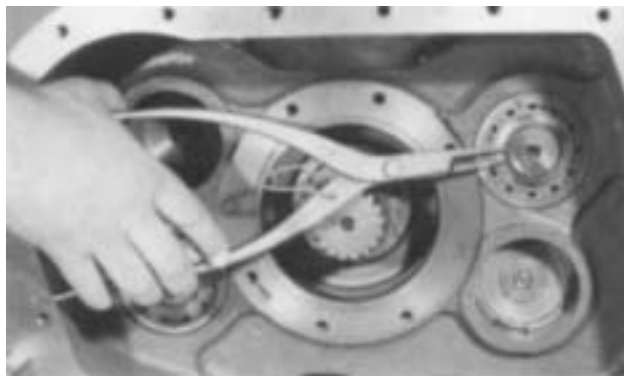

1. Remove the snap ring from the rear of each countershaft.



2. From inside the case, use a mallet and punch to drive the countershaft rear bearings to the rear and from the case bores and shafts.

NOTE: Removal procedures will most likely damage the bearings and removal should not be attempted unless replacement of the bearings is planned.



3. Cut the lockwires, turn out the lock screws and remove the two front bearing retaining plates.

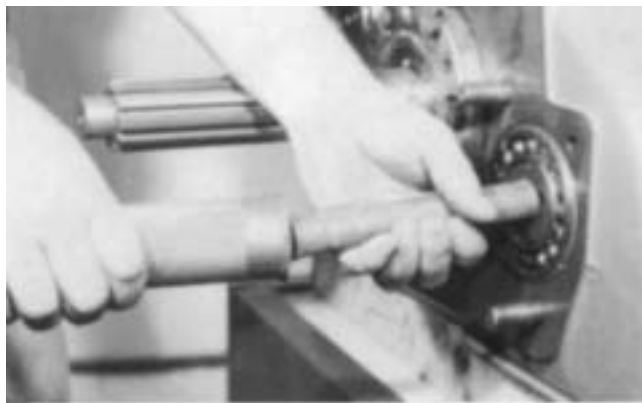

4. Use a soft bar and mallet to drive each countershaft as far to the rear as possible. This will partially unseat the front bearings.

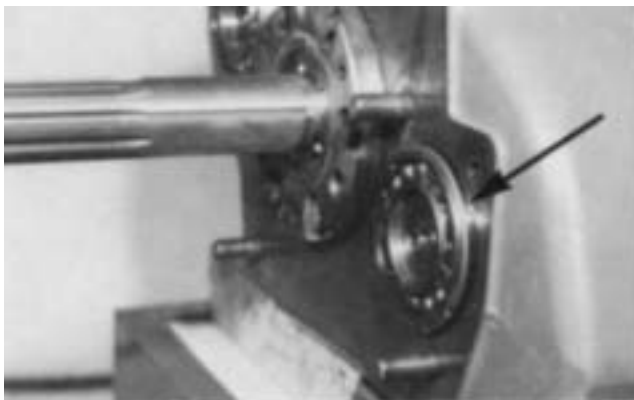

5. Use a soft bar and mallet on the rear of each countershaft to drive each shaft as far forward as possible, unseating the front bearings from the case bores. This will expose the front bearing snap rings.



6. Use a bearing puller to remove the countershaft front bearings.

D. Removal and Disassembly of the Mainshaft Assembly

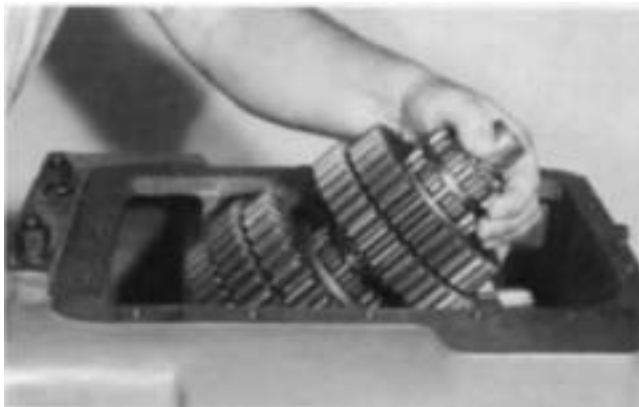

1. Block the right countershaft against the side of the case and move the mainshaft as far to the rear as possible. Tip the front of the mainshaft up and remove the assembly from the case. Use caution as the reverse gear is free and may fall from the shaft.

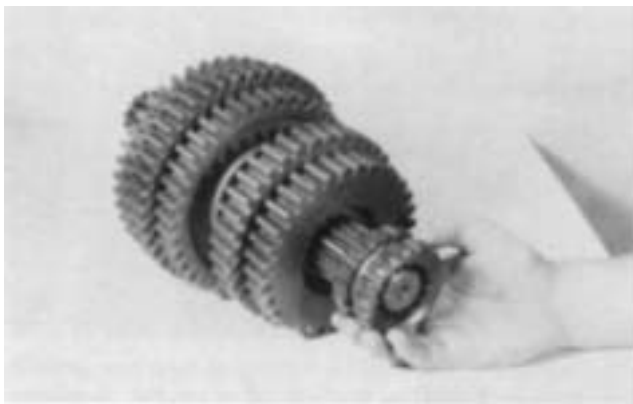

2. Remove the 4th-5th speed sliding clutch.

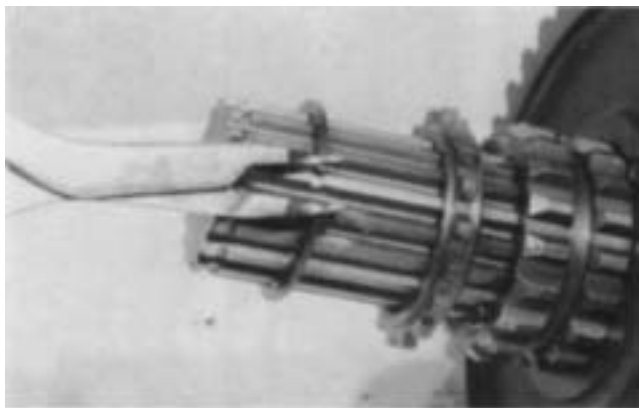

3. Remove the snap ring from the rear of the mainshaft.

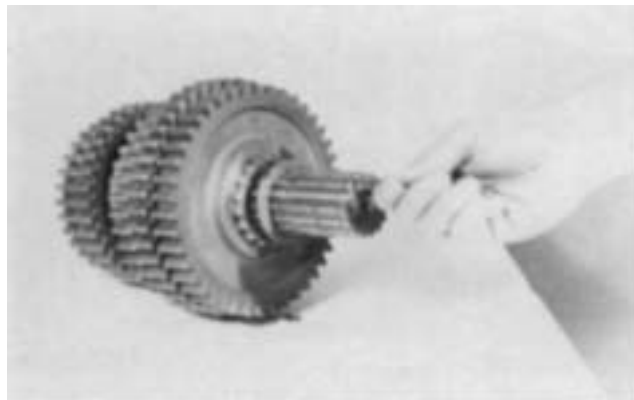

4. Remove the reverse gear spacer and pull the key to the rear and from the mainshaft.

NOTE: When removing washers, spacers and gears, note their location to facilitate reassembly of the mainshaft. Keep washers and spacers with the gear from which they were removed; there is one spacer and one washer for each gear. The spacers have external splines and the washers have internal splines.

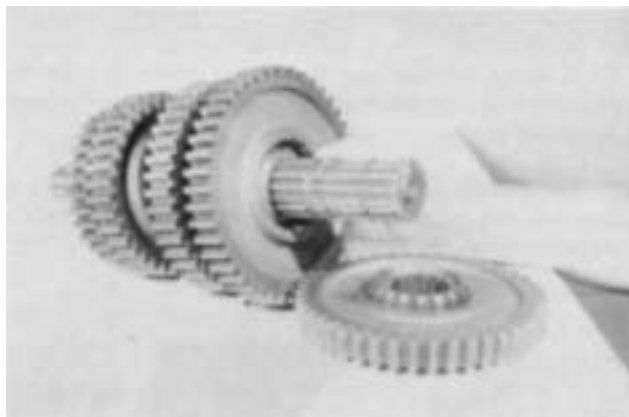

5. Work the washers, spacers and gears from the mainshaft. It will be necessary to turn the washers, located in the hubs of the gears, to align with the splines of the mainshaft. If necessary, remove the snap ring from the hub of each gear.

E. Removal and Disassembly of the Drive Gear Assembly

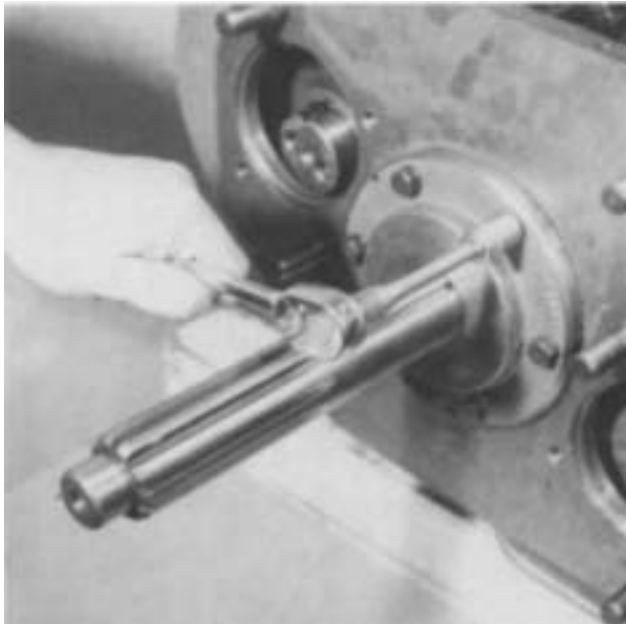

1. Turn out the front bearing cover retaining capscrews and from inside the case, use a soft bar and mallet to move the drive gear forward. This will force the front bearing cover away from the case. Remove the front bearing cover from the input shaft.

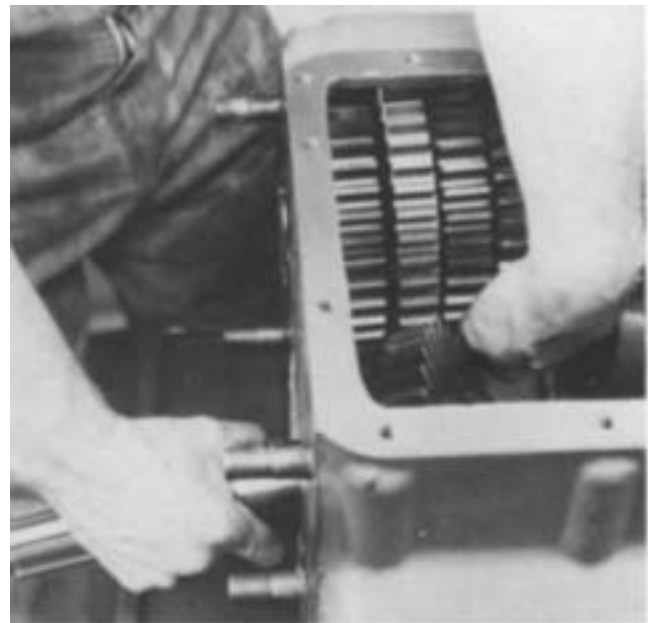

3. Move the drive gear assembly to the rear and into the case, working past the countershaft gears. Remove the drive gear assembly from the case.



2. Remove the snap ring from the drive gear bearing.



4. Relieve the drive gear bearing nut at the points where it is peened into the milled slots of the shaft.

Disassembly — Front Section

E. Disassembly of the Drive Gear Assembly - continued



5. Turn the bearing nut from the shaft. (LH thread)

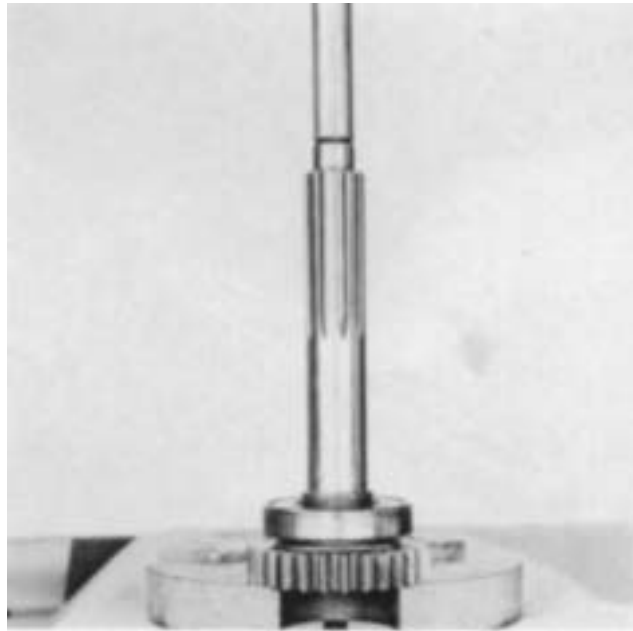

6. Using the rear face of the drive gear as abase, press the shaft through the gear to unseat the bearing from the shaft. This will free the bearing, spacer and drive gear. If necessary, remove the snap ring from the drive gear.

F. Removal and Disassembly of the Countershaft Assemblies

NOTE: Except for the number of teeth on the PTO gear, the countershaft assemblies are identical and are disassembled in the same manner.

IMPORTANT: Never use the PTO gear as a pressing base. The narrow thickness of this gear makes it susceptible to breakage.

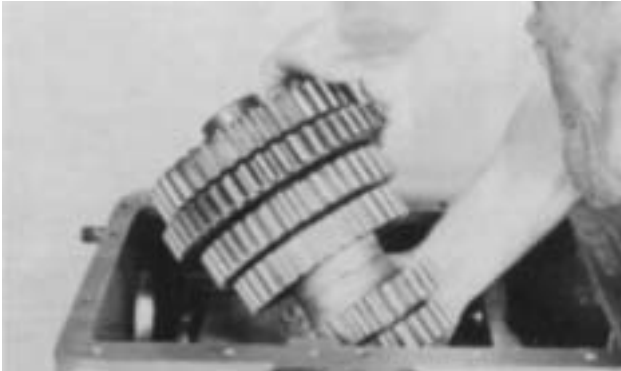

1. Move the right countershaft to the rear as far as possible, moving the front of the shaft to the inside of the case. Lift the shaft from the case and repeat the procedure for the left countershaft.

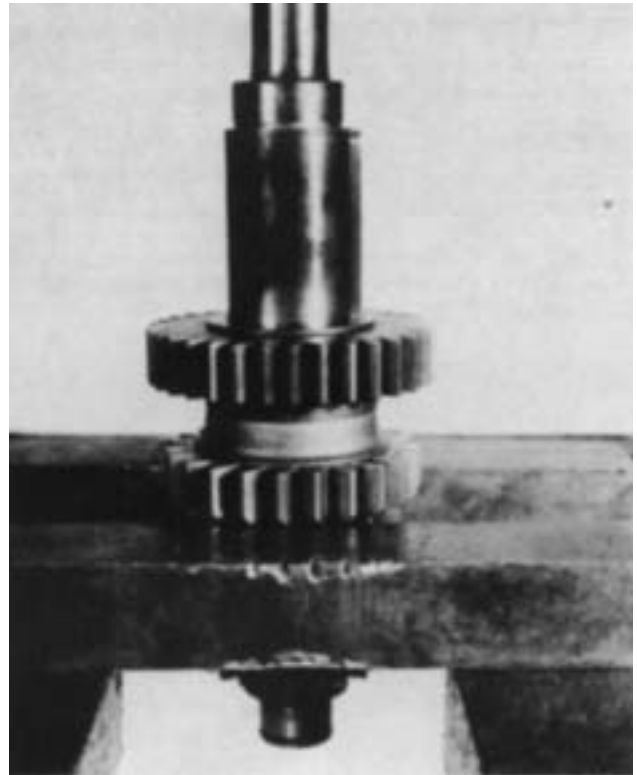

3. Using the 2nd speed gear as a base, press the 2nd and 3rd speed gears from the shaft. If necessary, use a hammer and punch to remove the key from the countershaft keyway.

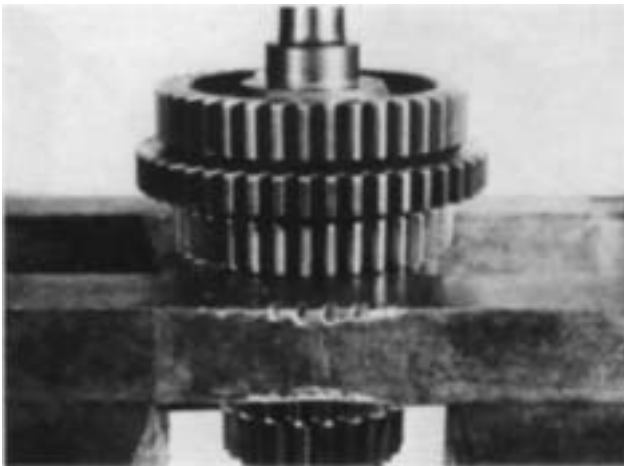

2. Remove the spacer from the front of the countershaft and using the 4th speed gear as a base, press the direct, PTO and 4th speed gears from the shaft. This will require a press of at least 25 ton capacity. Use a safety shield as a precaution.

G. Removal and Disassembly of the Right Reverse Idler Gear Assembly

NOTE: The right reverse idler gear assembly is identical to the left and is disassembled in the same manner.

IV. Auxiliary Section - RT-1110 Series

A. Removal and Disassembly of the Range Shift Cylinder Assembly



1. For ease of disassembly, mount the auxiliary section upright in a vise. Turn out the cap screws and remove the range shift cylinder cover.



4. Pull the yoke bar to the rear and out of the cylinder. Remove the piston from the housing.

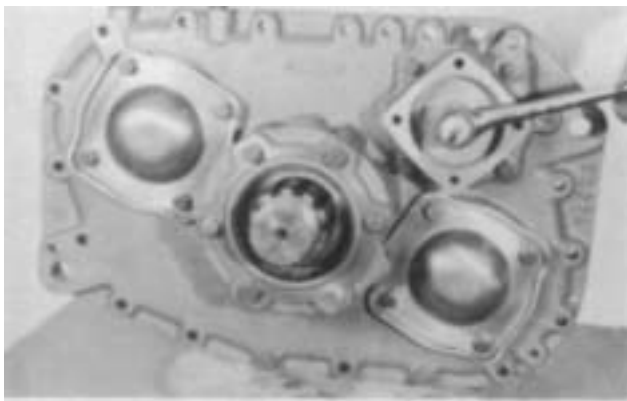

2. Turn the nut from the end of the shift yoke bar.



5. Remove the O-rings from the OD and ID of the piston.



3. Cut the lockwire and turn out the two yoke lock screws.



6. Turn out the cap screws and remove the shift cylinder housing from the auxiliary plate. Remove the shift yoke from the sliding clutch gear of the synchronizer assembly. If necessary, remove the O-ring from the bore in the cylinder housing.

6. Removal of the Auxiliary Countershaft Assemblies



1. Turn out the capscrews and remove the two rear bearing covers.



2. Remove the snap ring from the rear of each countershaft.



3. Use a soft bar and mallet to drive the countershaft forward and from the rear bearings.



4. Remove the bearings from the bores by tapping lightly and evenly to the rear with a soft bar.

NOTE: Check the bearing inner race on the front of each countershaft. If worn or damaged, remove with pry bars or appropriate jaw pullers. If the auxiliary countershaft front bearings are to be changed, these inner races must be changed also.

C. Removal and Disassembly of the Synchronizer Assembly



1. Pull the synchronizer assembly from the splines of the output shaft.



2. Pull the direct (high range) cone synchronizer from the pins of the low speed synchronizer ring. Cover the assembly with a cloth as the three springs will be released at the blocker pin locations.

C. Removal and Disassembly of the Synchronizer Assembly - continued

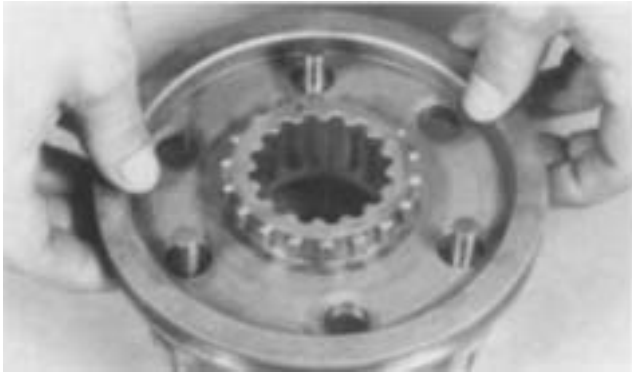

3. Remove the sliding clutch gear from the pins of the low speed synchronizer.

D. Disassembly of the Low Speed Gear and Tailshaft Assembly

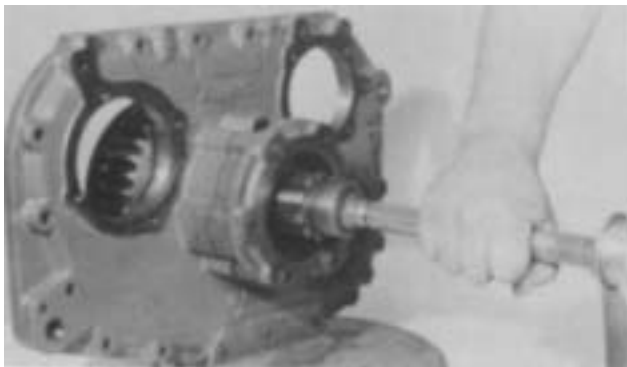

1. Use a soft bar and mallet to drive the output shaft forward and through the rear bearing.

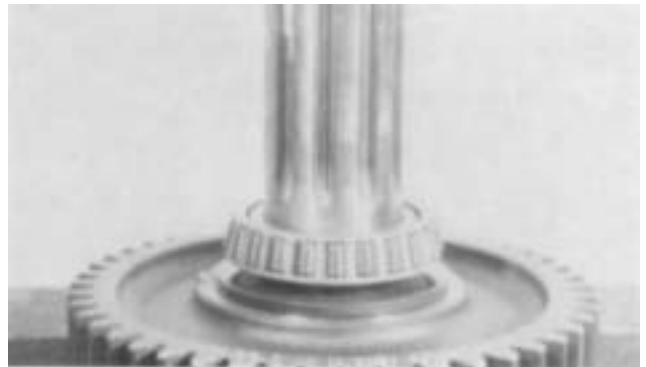

3. Using the front face of the low speed gear as a base, press that shaft through the gear and bearing, freeing bearing, washer and gear from shaft.



2. Remove the bearing inner spacer from the shaft.



4. If necessary, remove snap ring from the ID of the low speed gear.



5. Remove the splined spacer from the shaft.



6. Remove the stepped washer from the shaft.



7. Turn out the cap screws and remove the rear bearing cover. If necessary, remove the oil seal from the cover.



8. Remove the bearing rear cone from the housing.



9. Remove the two bearing cups and outer spacer from the housing bore.

V Auxiliary Section - RT-12510 Series

A. Removal and Disassembly of the Range Shift Cylinder Assembly



1. For ease of disassembly, mount the auxiliary section up-right in a vise. Turn out the capscrews and remove the range shift cylinder cover.

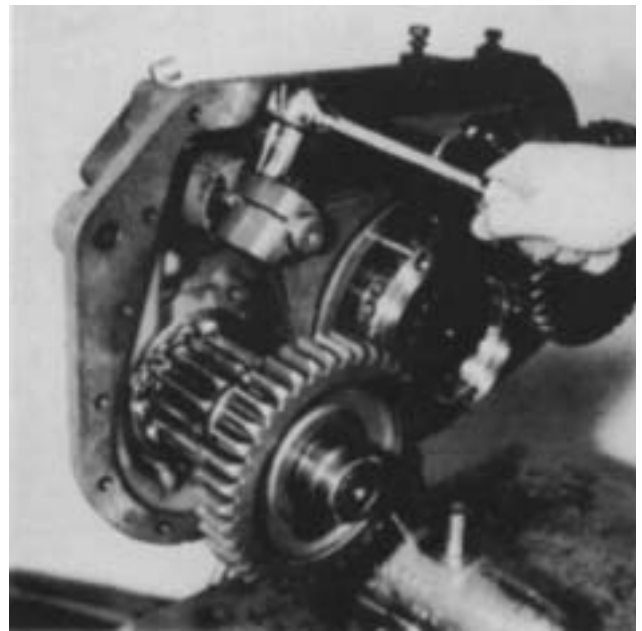

3. Cut the lockwire and turn out the two yoke lock screws.

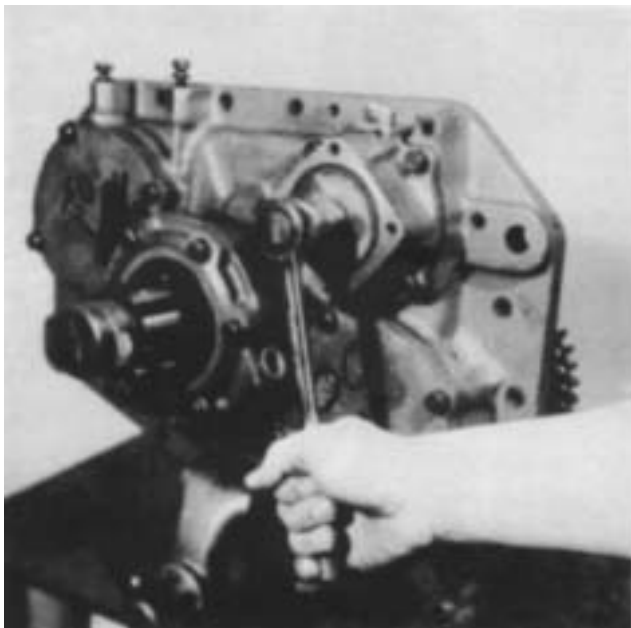

2. Turn the elastic stop nut from the end of the yoke bar.

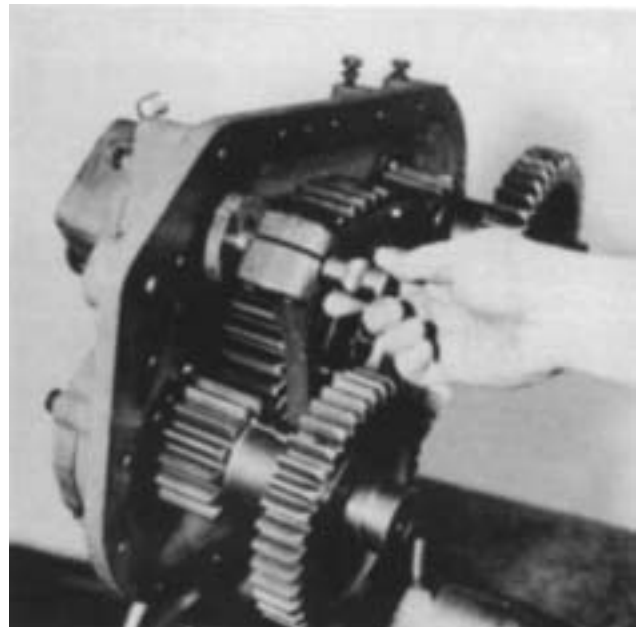

4. Pull the bar forward and out of the shift cylinder. Remove the piston from the cylinder bore.



5. Remove the O-rings from the OD and ID of the piston and from the bore in the shift cylinder.

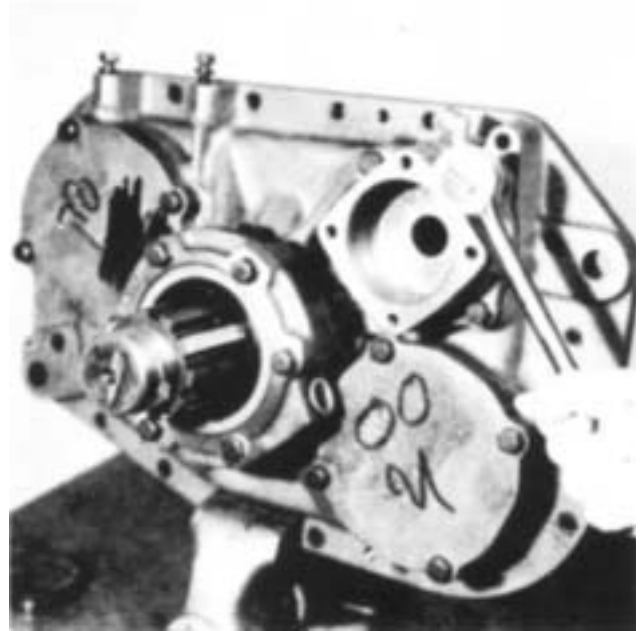

6. Turn out the capscrews and remove the shift cylinder housing. Remove the shift yoke from the sliding clutch gear of the synchronizer. If necessary, remove O-ring from bore in cylinder housing.

B. Removal of the Auxiliary Countershaft Assemblies

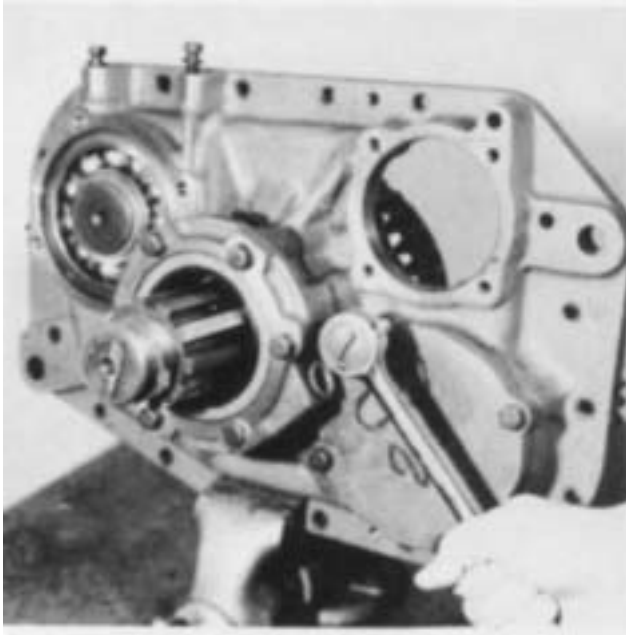

1. Turn out the capscrews and remove the two rear bearing covers.

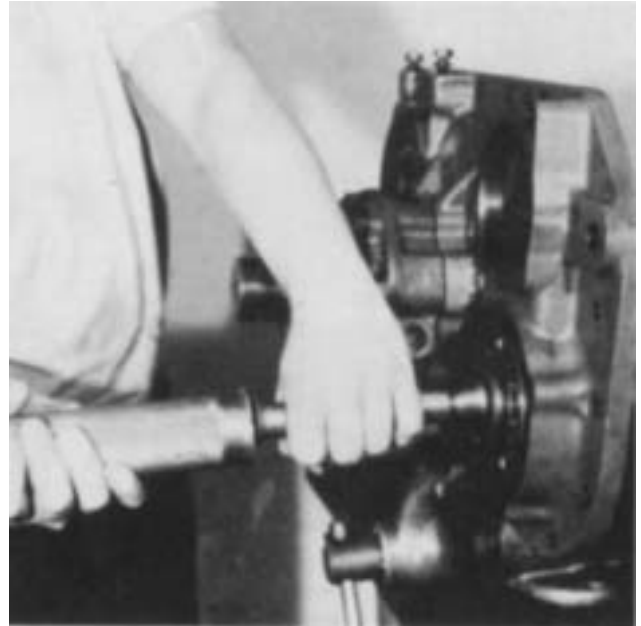

3. Use a soft bar and mallet to drive the countershaft forward and from the rear bearings.

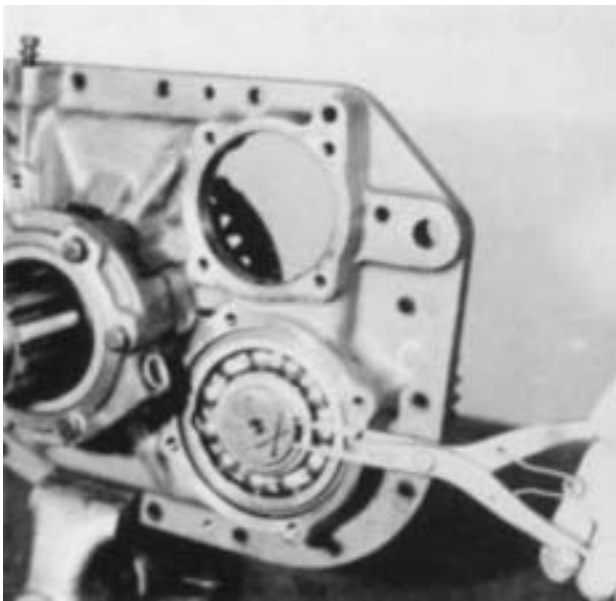

2. Remove the snap ring from the rear of each countershaft.

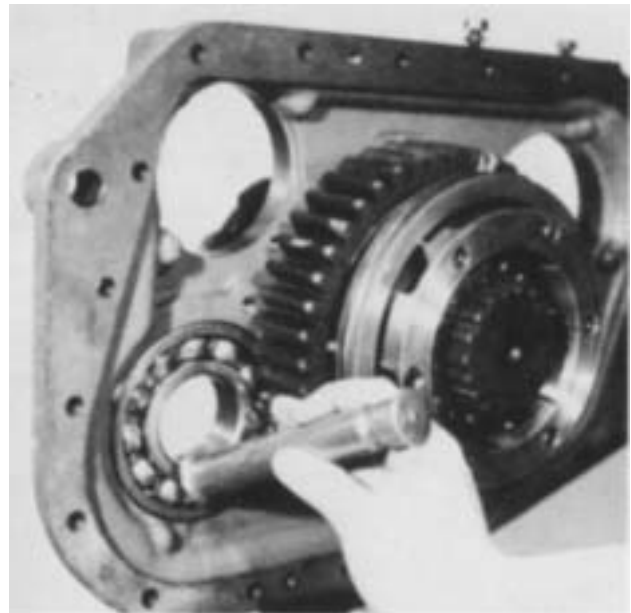

4. Remove the bearings from bores by tapping lightly and evenly to the rear with a soft bar.

NOTE: Check bearing inner races on front of each countershaft. If worn or damaged, remove with pry bars or appropriate jaw pullers.

C. Removal and Disassembly of the Synchronizer Assembly -- continued

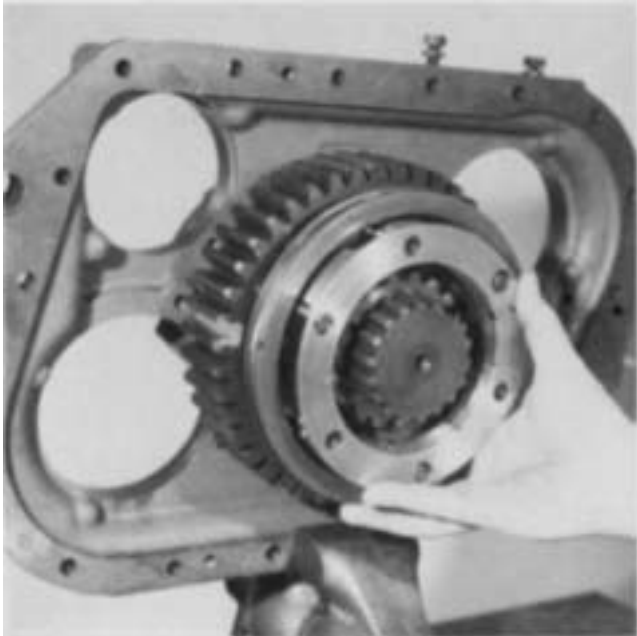

1. Pull the synchronizer assembly from the splines of the output shaft.

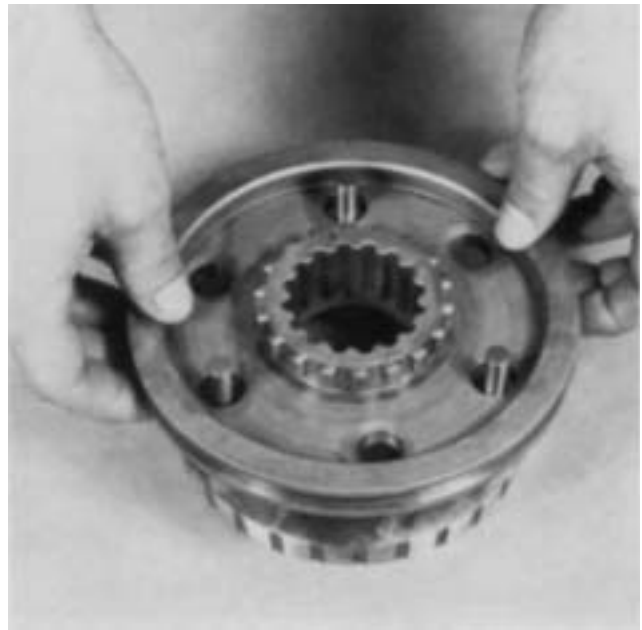

3. Remove the sliding clutch gear from the pins of the low speed synchronizer.



2. Pull the direct (high range) cone synchronizer from the pins of the low speed synchronizer ring. Cover with a cloth as the three springs will be released at the blocker pin locations.

D. Removal and Disassembly of the Output Shaft Assembly

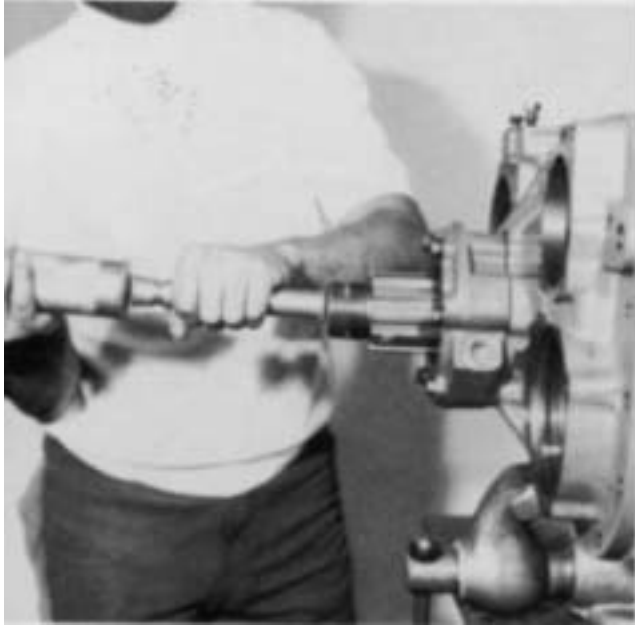

1. Use a soft bar and mallet to drive the output shaft forward and from the rear bearing assembly.

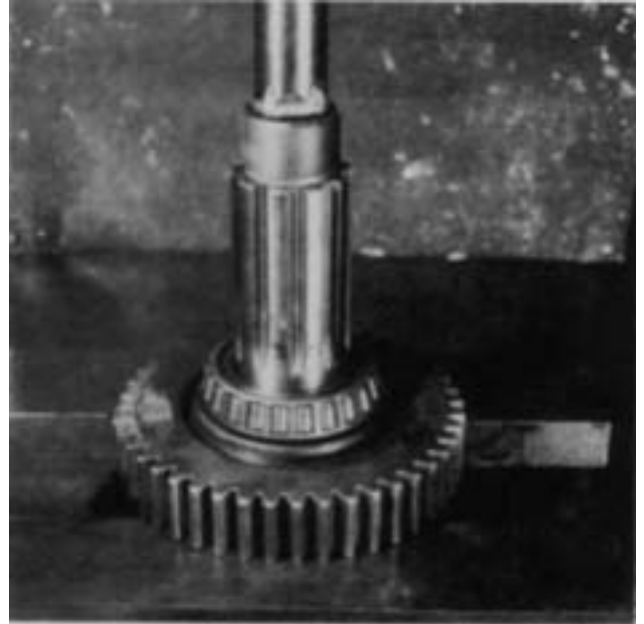

3. Using the front face of the low speed gear as a base, press the shaft through the gear and bearing. Remove the splined spacer from the hub of the gear.



2. Remove the bearing inner spacer from the shaft.

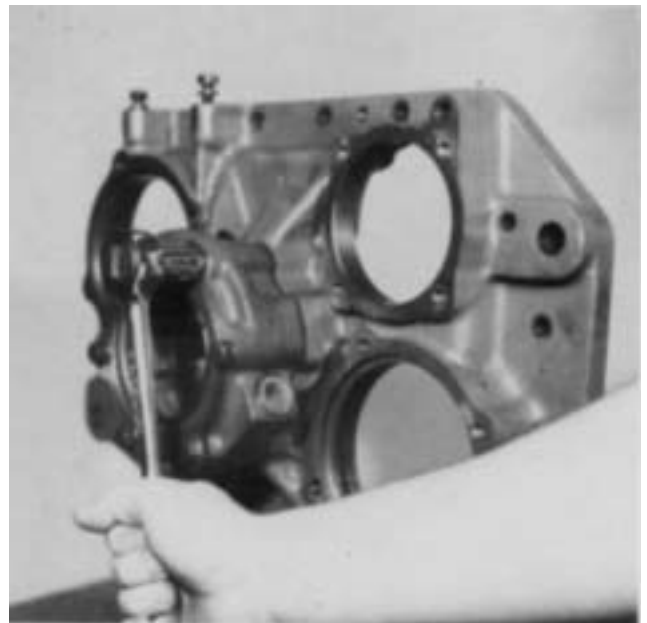

4. Turn out the capscrews and remove the rear bearing housing. If necessary, remove the oil seal from the housing. Remove the rear bearing cone from the housing.



5. Remove the two bearing cups and outer spacer from the auxiliary plate bore.

VI Auxiliary Section - RT-12515 Series

A. Removal and Disassembly of the Range Shift Cylinder Assembly

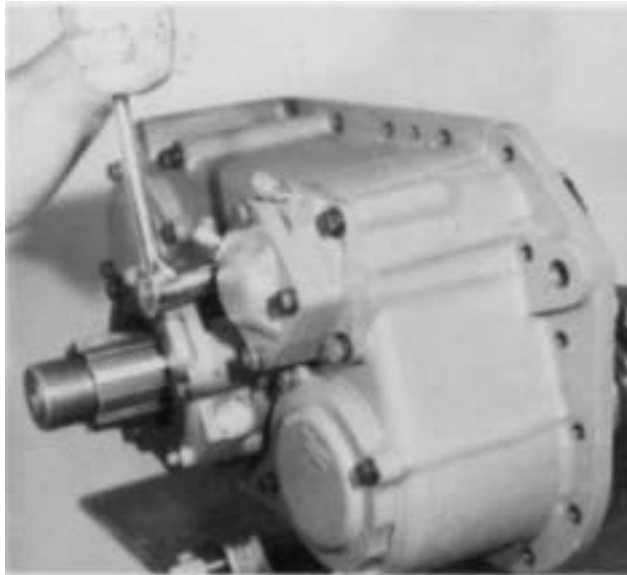

1. For ease of disassembly, mount the auxiliary section in a vise in the upright position. Turn out the capscrews and remove the range shift cylinder cover.

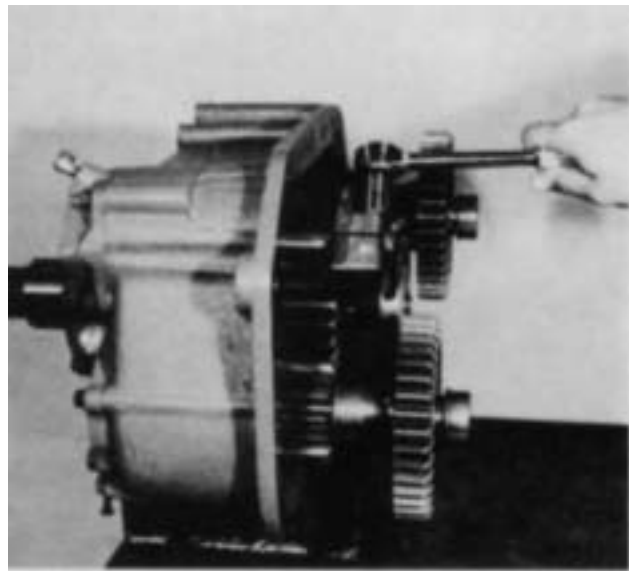

3. Cut the lockwire and turn out the two yoke lockscrews.

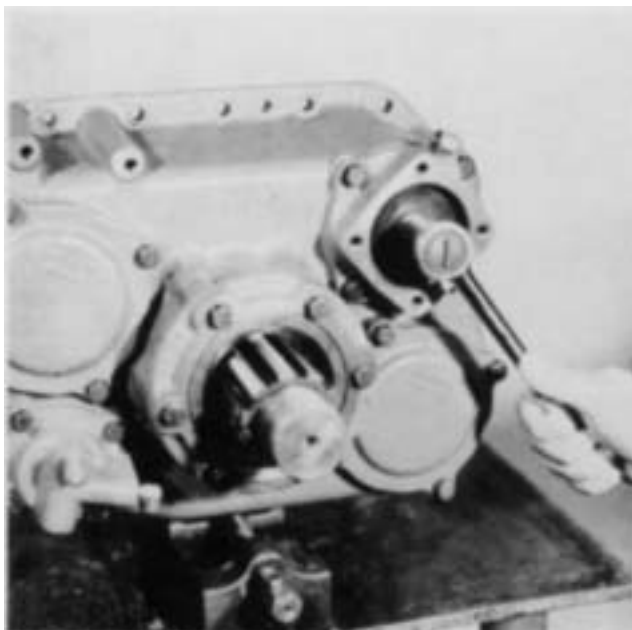

2. Turn the nut from the end of the yoke bar.

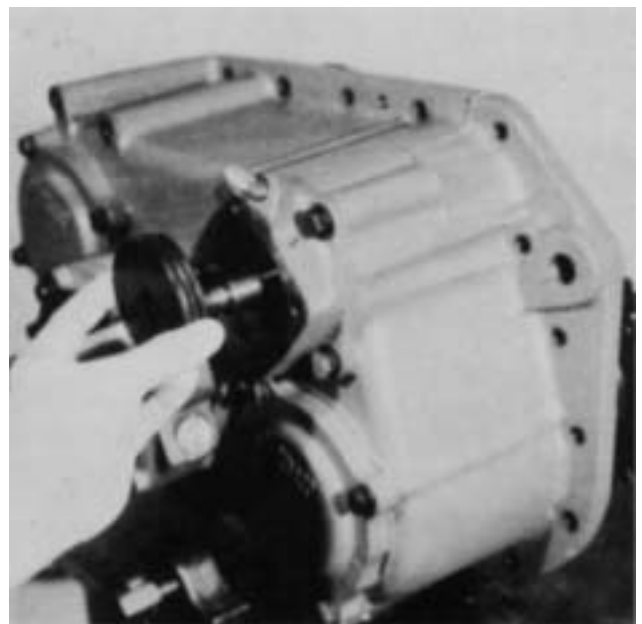

4. Push the yoke bar to the rear and from the housing. Remove the piston from the bar.



5. Remove the O-rings from the piston.

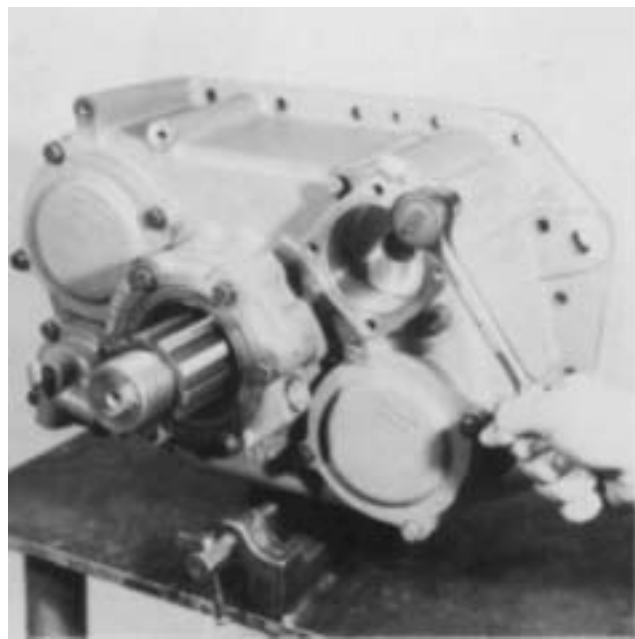

6. Turn out the cap screws and remove the shift cylinder housing. If necessary, remove the O-ring from the ID of the housing.

B. Removal of the Auxiliary Countershaft Assemblies.



1. Turn out the capscrews and remove the two rear bearing covers.



2. Remove the snap ring from the rear of each auxiliary countershaft.



3. Use a soft bar and mallet to drive the countershaft forward and from the rear bearings.

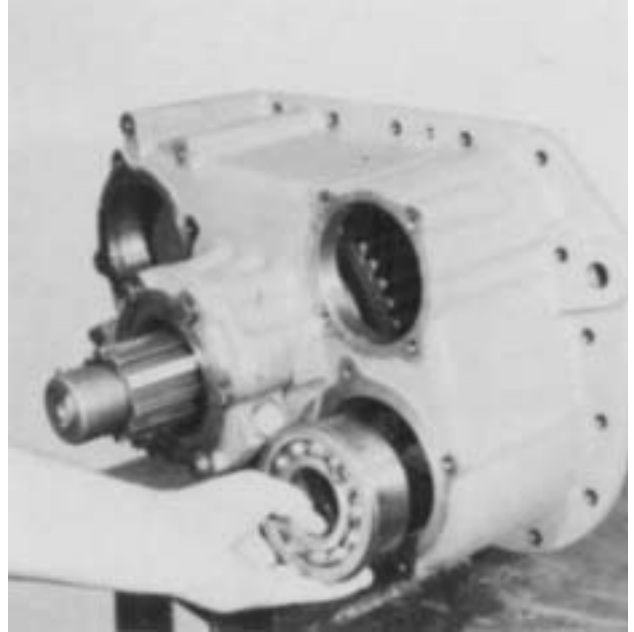

4. Remove the bearings from the bores by tapping lightly and evenly to the rear with a soft bar.



5. If necessary, remove the bearing inner race from the front of each countershaft with a puller or pry bars.

C. Removal and Disassembly of the Synchronizer Assembly



1. Pull the synchronizer assembly from the splines of the output shaft.

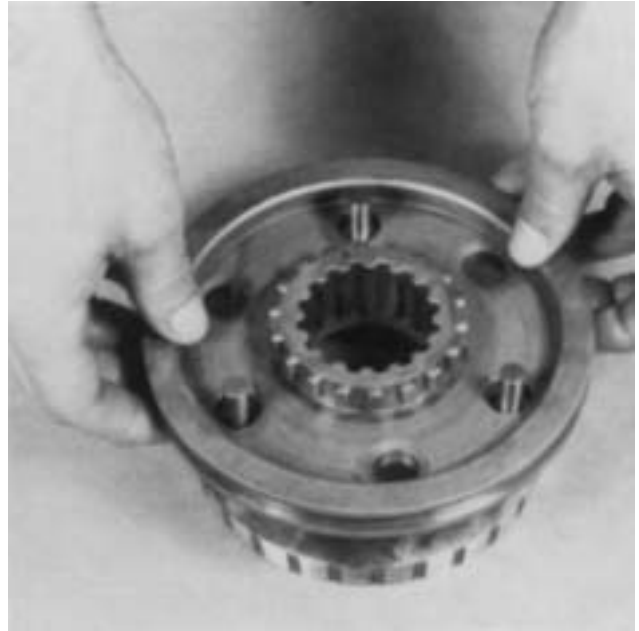

3. Remove the sliding clutch from the pins of the low speed synchronizer.



2. Pull the direct (high range) cone synchronizer from the pins of the low speed synchronizer ring. Cover the assembly with a cloth as the three springs will be released at the blocker pin locations.

D. Removal of the Low Range Gear and Range Mainshaft Assembly

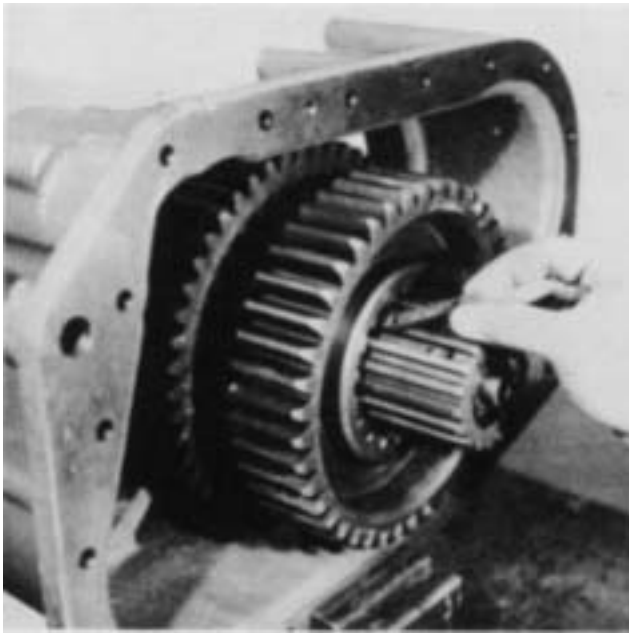

1. Remove the key from the keyway between the splines of the range mainshaft.

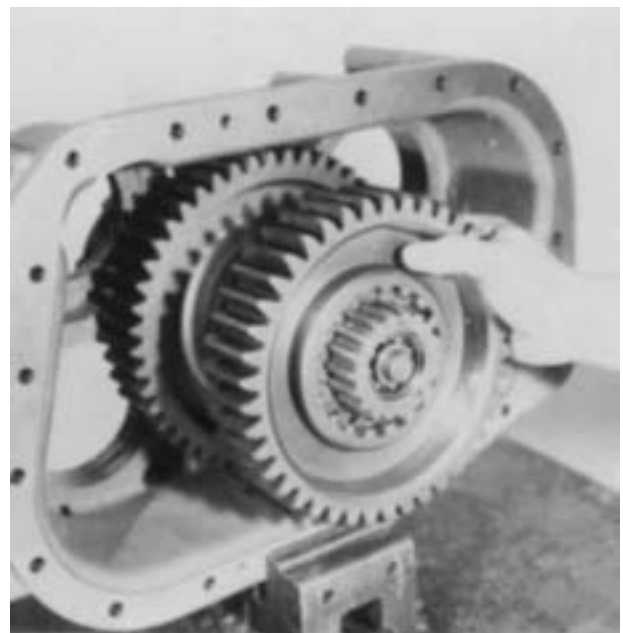

3. Pull the gear and washer forward and off the splines of the range mainshaft.

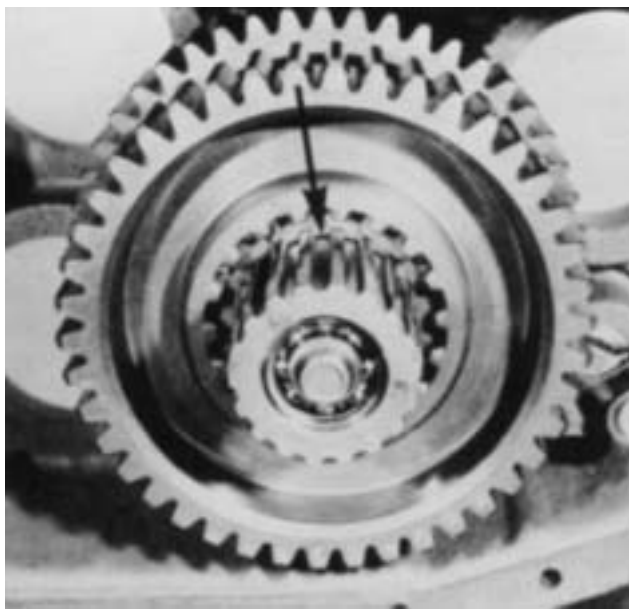

2. Turn the washer located in the hub of the gear so that the splines on the washer align with the splines on the shaft.

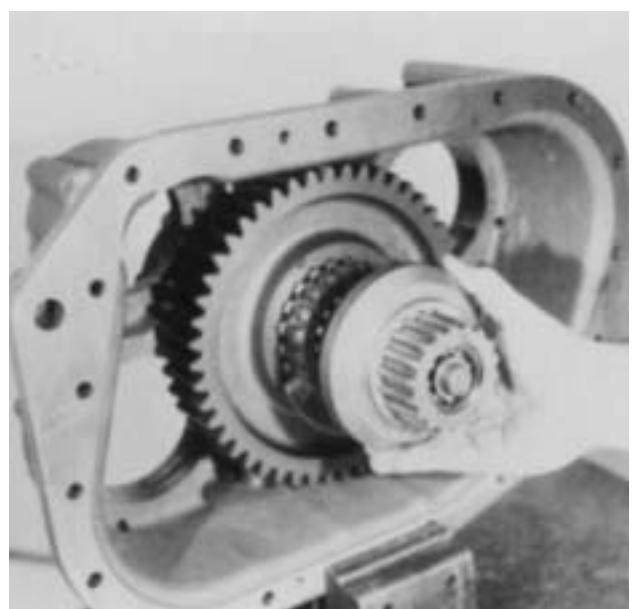

4. Remove the coupler from the shaft.

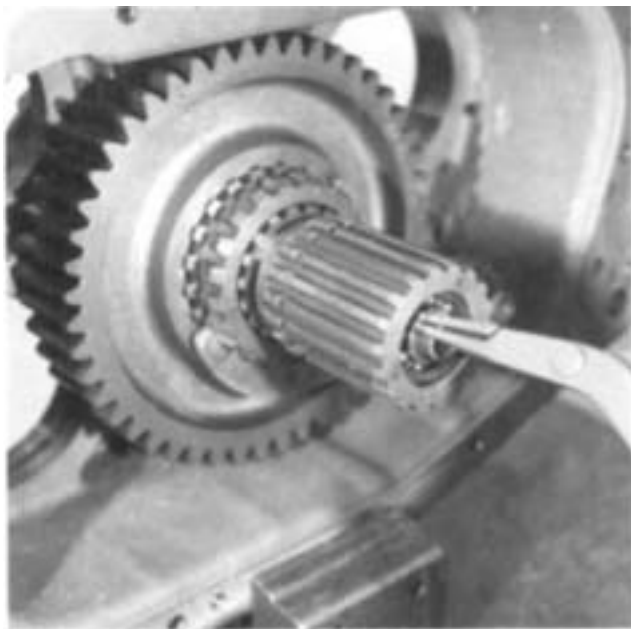

5. Remove the snap ring from the output shaft quill.



7. Remove the bearing from the shaft. If necessary, use an inside jaw impact puller.

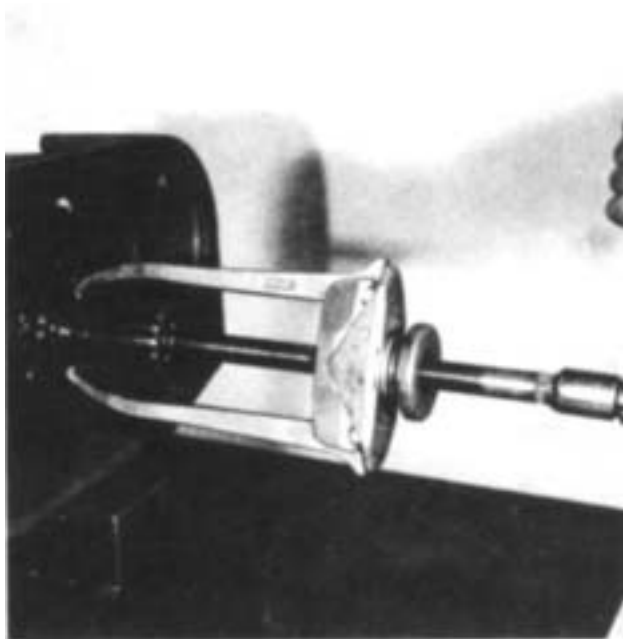

6. Use a puller or pry bars to pull the range mainshaft forward and from the output shaft quill.



8. If necessary, remove the snap ring from the OD of the shaft. Check the bushing in the shaft and replace if worn.

E. Removal and Disassembly of the Deep Reduction Shift Cylinder



1. Cut the lockwire and turn out the lock screw from the shift yoke.



2. Pull the shift yoke and clutch forward and from the auxiliary housing.



3. Turn out the capscrews and remove the shift cylinder cover.



4. Remove the yoke bar from the housing. Remove the O-ring from the bar.

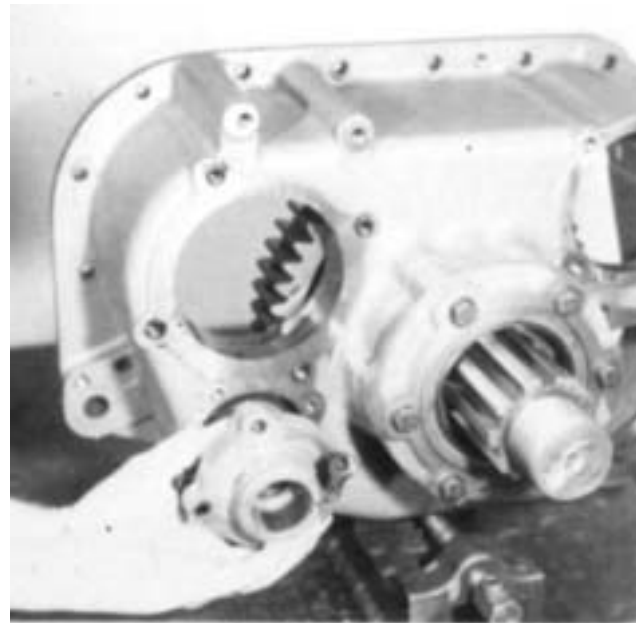

5. Remove the cylinder housing from the auxiliary housing. Remove the O-ring from the bore in the housing.

F. Removal and Disassembly of the Output Shaft Assembly



1. Turn out the cap screws and remove the rear bearing housing. If necessary, remove the oil seal from the housing.

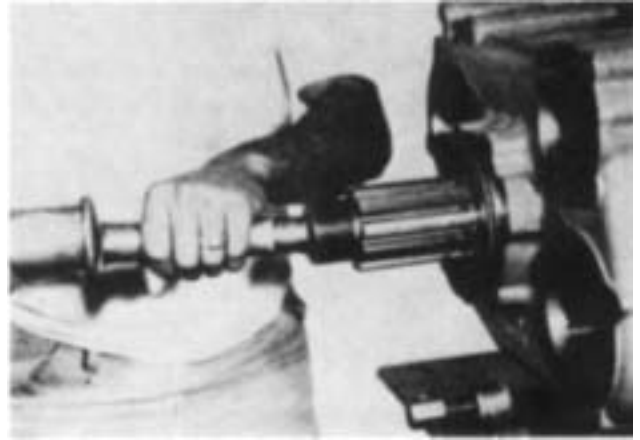

4. Use a soft bar and mallet to drive the output shaft forward and from the auxiliary housing.

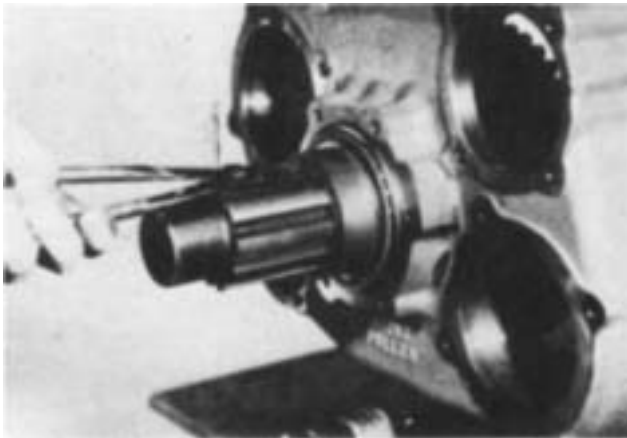

2. Remove the snap ring from the output shaft.

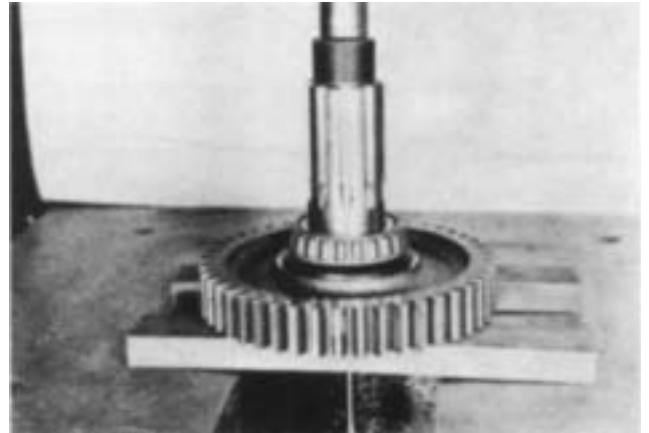

5. Use the deep reduction gear as a base to press the rear bearing from the output shaft. This will free the gear, washer, spacer and oil deflector.



3. Remove the speedometer drive gear or replacement spacer from the shaft.

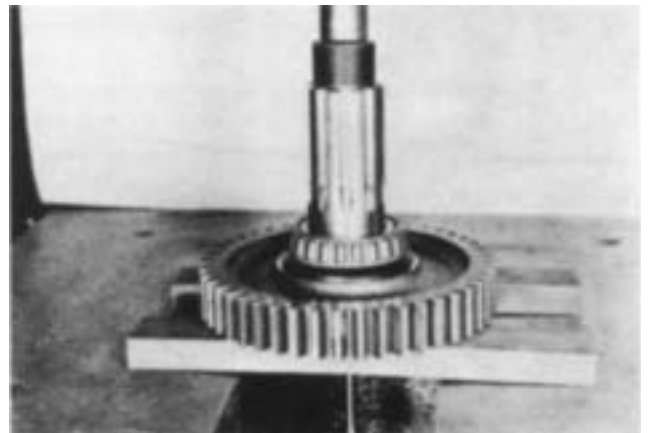

6. Remove the two bearing cups and outer spacer from the auxiliary housing bore.

Inspection

Before reassembling the transmission, the individual parts should be carefully checked to eliminate those damaged from previous service. This inspection procedure should be carefully followed to insure the maximum of wear life from the rebuilt unit.

The cost of a new part is generally a small fraction of the total cost of downtime and labor, should the use of a questionable part make additional repairs necessary before the next regularly scheduled overhaul.

Recommended inspection procedures are set forth in the following checklist:

A. Bearings

1. Wash all bearings in clean solvent. Check balls, rolls and races for pits and spalled areas. Replace bearings which are pitted or spalled.



2. Lubricate bearings which are spalled or pitted and check for axial and radial clearances. Replace bearings with excessive clearances.

3. Check fits of bearings in case bores. If outer races turn freely in the bores, the case should be replaced.

B. Gears

1. Check operating gear teeth for pitting on the tooth faces. Gears with pitted teeth should be replaced.
2. Check all engaging gear teeth. Gears with teeth worn, tapered or reduced in length from clashing in shifting should be replaced.
3. Check axial clearances of gears. Where excessive clearance is found, check gear snap ring, washer, spacer and gear hub for excessive wear. Maintain .005 to .012 axial clearance of mainshaft gears.

C. Splines

1. Check splines on all shafts for wear. If sliding clutch gears, companion flange or clutch hub have worn into the sides of the splines, the shafts in this condition should be replaced.

D. Thrust Washers

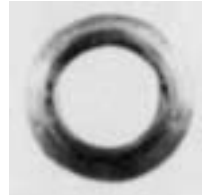

1. Check surfaces of all thrust washers. Washers scored or reduced in thickness should be replaced.

E. Reverse Gear and Shaft

1. Check bearing sleeve for wear from action of roller bearings.

F. Gray Iron Parts



1. Check all gray iron parts for cracks and breaks. Replace or repair parts found to be damaged. Heavy castings may be welded or brazed providing the cracks do not extend into bearing bores or bolting surfaces.

G. Clutch Release Parts

1. Check clutch release parts. Replace yokes worn at cam surfaces and gearing carrier worn at contact pads.
2. Check pedal shafts. Replace those worn at bearing surfaces.

**H. Shifting Bar Housing Assembly**

1. Check yokes and blocks for wear at pads and lever slot. Replace worn parts.



2. Check yokes for alignment. Straighten those which are sprung.
3. Check lockscrews in yokes and blocks. Tighten and rewire those found loose.
4. If housing has been dismantled, check neutral

notches of shifting bars for wear from interlock balls. Bars indented at points adjacent to the neutral notch should be replaced.

I. Gearshift Lever Housing Assembly

1. Check spring tension on shift lever. Replace tension spring and washer if lever moves too freely.

2. If housing is dismantled, check pivot pin and corresponding slot in lever for wear. Replace both parts if worn.

J. Bearing Covers

1. Check covers for wear from thrust of adjacent bearing. Replace covers worn and grooved from thrust of bearing outer race.
2. Check bores of covers for wear. Replace those worn oversize.

K. Oil Return Threads and Seals

1. Check oil return threads in front bearing cover. If sealing action of threads has been destroyed by contact with input shaft, replace the cover.
2. Check oil seal in mainshaft rear bearing cover. If sealing action of lip has been destroyed, replace seal.

L. Synchronizers

1. Check high and low range synchronizers for burrs, uneven and excessive wear at contact surface.
2. Check blocker pins for excessive wear or looseness.
3. Check synchronizer contact surfaces on the high and low range gears for excessive wear.
4. Check contact surfaces of synchronizers for imbedded metal particles.

Torque Ratings

Recommended torque ratings, location and thread sizes of capscrews and nuts are listed below. Capscrew lengths are given for reference purposes as a guide for installation at proper locations.

Correct torque application is extremely important to assure long transmission life and dependable performance. Over-tightening and under-tightening can result in a loose installation and, in many instances, eventually cause damage to transmission gears, shafts or bearings. Do not torque capscrews dry.

CAPSCREWS			
Location	Qty.	Thread Size And Length	Torque Rating Foot-Pounds
Air Valve	4	1/4-20 x 1 -3/4	15-20
Air Valve Adapter Plate	2	1/4-20 x 7/8	15-20
Filter Bracket	2	3/8-16 x 3/4	20-25
*PTO Cover. small	6	3/8-16 x 3/4	18-23 (12-15 with oil filter)
Hole-Gear Shift Cylinder (RT-12515 only)	4	5/16-18 x 1-7/8	20-25
Aux. Drive Gear Retainer Ring	6	3/8-16 x 1	35-45
Range Shift Cylinder	4	3/8-16 x 1	
Range Shift Cylinder Cover	4	3/8-16 x 1	
Range Shift Cylinder Cover (RT-12515 only)	4	3/8-16 x 1-1/4	
Shift Bar Housing	16	3/8-16 x 1-1/4	
Gear Shift Lever Housing	4	3/8-16 x 1-1/4	
Front Bearing Cover	6	3/8-16 x 1-1/4	
Countershaft Rear Bearing Covers	8	3/8-16 x 1-1/4	
Rear Plate to Case	18	3/8-16 x 2	
	1	3/8-16 x 1-3/4	
Rear Plate to Case (RT-12515 only)	18	3/8-16 x 1-1/2	
	1	3/8-16 x 2	
Mainshaft Rear Bearing Cover	6	3/8-16 x 2-3/4	
C/S Front Bearing Retainers	4	3/8-24 x 1	
PTO Cover large	8	7/16-14 x 1-1/4	50-65
Clutch Housing to Case	2	1/2-13 x 1-1/2	90-100
	2	1/2-13 x 3-1/2	

*NOTE: Installing the capscrews with more than 23 ft-lbs. of torque will force the corners of the PTO cover away from the case with resultant oil leakage.

NUTS			
Location	Qty .	Thread Size	Torque Rating Foot-Pounds
Reverse Idler Shafts	2	5/18-18	75-80
Range Shift Piston	1	5/8-18	70-85
Clutch Housing to Case	6	5/8-18	180-190
Drive Gear	1	2-1/8-16	250-300
Companion Flange or Yoke	1	2-16	450-500

Location of Gaskets

Seat gasket with shellac on part to be installed. Use new gaskets throughout when assembling transmission. Gaskets are located between the following parts:

RT-1110, RT-12510

1. Gearshift lever housing and shift bar housing.
2. Shift bar housing and case.
3. Air valve adapter plate and case.
4. Air valve and adapter plate.
5. Clutch housing and case.
6. Front bearing cover and case.
7. Rear plate and case.
8. Mainshaft rear bearing cover and rear plate.
9. Auxiliary range shift cylinder cover and cylinder.

10. Auxiliary range shift cylinder and rear plate.
11. Right auxiliary countershaft rear bearing cover and rear plate.
12. Left auxiliary countershaft rear bearing cover and rear plate.
13. Large PTO cover and case.
14. Small PTO cover and case.

RT-12515

To the above list add:

1. Hole-gear shift cylinder cover and cylinder.
2. Hole-gear shift cylinder and case.

General Precautions for Reassembly

IMPORTANT: Read this section before starting the detailed reassembly procedures.

Make sure that interiors of case and housings are clean. It is important that dirt be kept out of transmission during reassembly. Dirt is abrasive and can damage polished surfaces of sleeves, bushings, bearings and washers. Use certain precautions, as listed below, during reassembly.

1. **GASKETS** -- Use new gaskets throughout the transmission as it is being rebuilt. Make sure all gaskets are installed, as omission of gasket can result in oil leakage or misalignment of bearing covers. See "Location of Gaskets" heading.



2. **CAPSCREWS** -- To prevent oil leakage, use thread sealant on all capscrews. See torque rating chart for recommended torque.

3. **O-RINGS** - Lubricate all O-rings with Fuller part no. 71206 or 71203 silicone lubricant.

4. **INITIAL LUBRICATION** Coat all thrust washers and splines of shafts with Lubriplate during installation to provide initial lubrication, preventing scoring and galling.

5. **AXIAL CLEARANCES** D Maintain original axial clearances of mainshaft forward speed gears of .005" to .012". Mainshaft reverse gear clearance is .005" to .012".

6. **BEARINGS** - Use of flanged-end bearing drivers is recommended for the installation of bearings. These



drivers apply equal force to both races of bearing, preventing damage to balls and races and maintaining correct bearing alignment with shaft and bore. If tubular or sleeve type driver is used, apply force only to inner race.

7. **UNIVERSAL JOINT COMPANION FLANGE** - Pull the companion flange tightly into place with the mainshaft nut, using 450-500 foot-pounds of torque. Make sure the



speedometer gear has been installed on yoke. If a speedometer gear is not used, a replacement spacer of the same width must be used. Failure to pull the yoke or flange tightly into place will permit the shaft to move axially with resultant damage to rear bearing.

REASSEMBLY INSTRUCTIONS

1. Auxiliary Section - RT-1110 Series

A. Reassembly of the Output Shaft and Rear Bearing Assembly

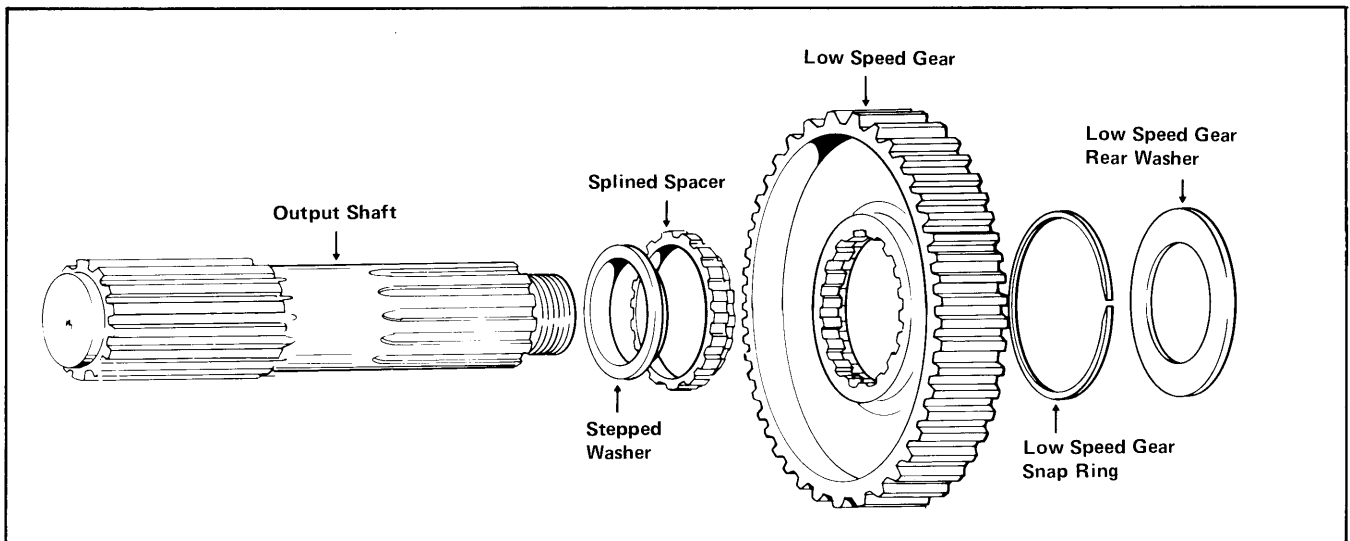

1. Set the output shaft on bench with threaded end up and install the stepped washer, large diameter down.

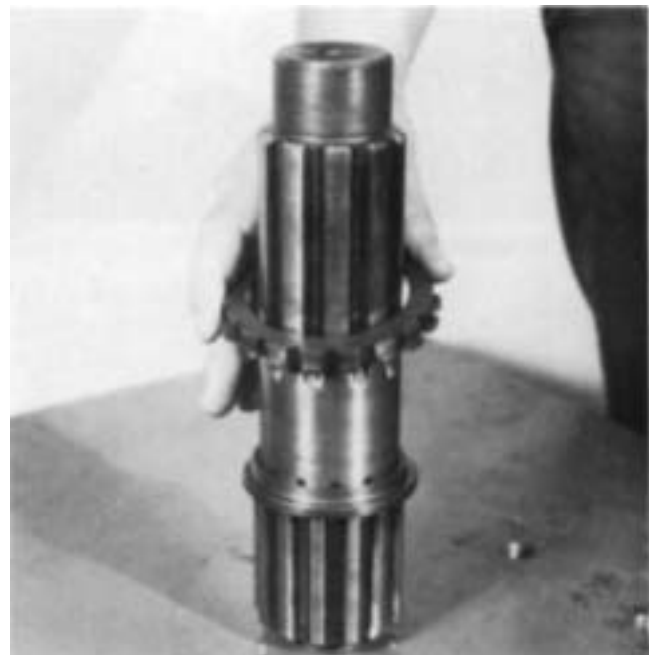

2. Install the splined spacer on the shaft, large diameter down.

A. Reassembly of the Output Shaft Assembly - continued



3. If previously removed, install the snap ring in the ID of the low speed gear and install the gear on-the shaft, flat side up.



4. Install the washer on the shaft.



5. Install the front bearing cone on the shaft and against the washer, taper up. Bearing is a matched set; make sure correct cone for cup is used as indicated by markings.

NOTE: Heating of bearing cones for installation is recommended, provided the bearing is not heated over 275°F. Heat lamps are recommended as heat source.



6. Install the bearing inner spacer on the shaft.



7. Place the front cup of the rear bearing into the rear of the housing bore, taper to the inside.



8. Place the bearing outer spacer on the cup and place rear cup on the spacer. Tap the two cups and spacer evenly into the rear bore until the lip of the rear cup seats on the housing.

B. Reassembly and Installation of the Synchronizer Assembly



1. Place the larger low speed ring on the bench with the pins upward and install the sliding clutch on the ring, protruding clutching teeth down.

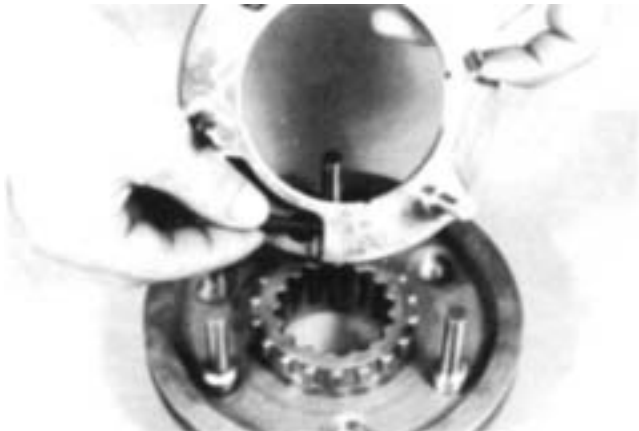

2. Install the three springs in the direct ring.

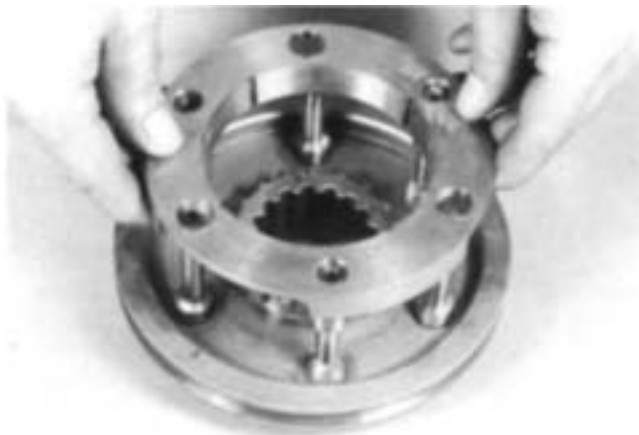

3. Install the direct ring on the low speed ring pins, seating the springs against the pins.

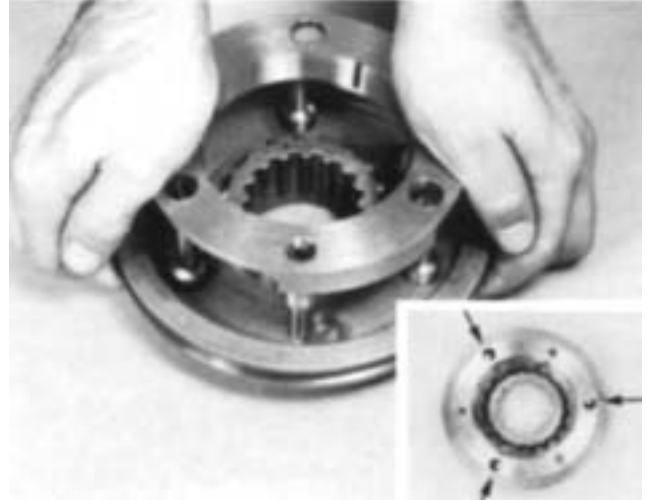

4. Apply pressure to the direct ring while twisting counter-clockwise to fully seat the direct ring on the low speed ring pins.



5. Set the synchronizer assembly on blocking approximately 2" high on a bench large enough to accommodate the rear housing.

C. Timing and Installation of the Auxiliary Countershafts and Output Shaft



1. On the small diameter low range gear of each counter-
shaft, mark the tooth which is stamped with an "O".

IMPORTANT: Make sure that the bearing inner race has been installed on the front of each auxiliary counter-
shaft, large diameter towards the gear.



3. Install the output shaft assembly on the synchronizer,
meshing the splines of the shaft with the synchronizer.

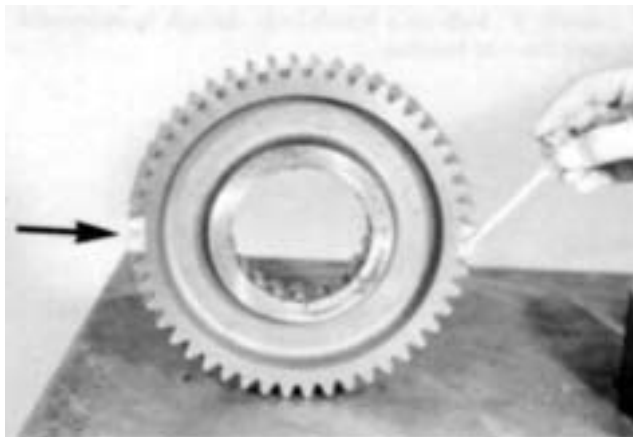

2. Mark any two adjacent teeth on the low speed gear and
then mark the two teeth directly opposite.



4. Place the countershaft into position against the output
shaft, meshing the marked tooth on each countershaft
between a set of marked teeth on the low speed gear.



5. Place the auxiliary housing down over the assembly, centering the countershafts in the rear bearing bores.



8. Install the countershaft rear bearings on the shafts and in the bores.

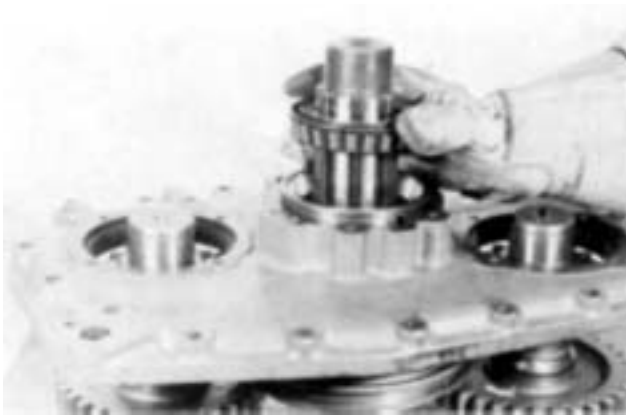

6. Heat the rear bearing cone and install it on the output shaft, taper facing down.

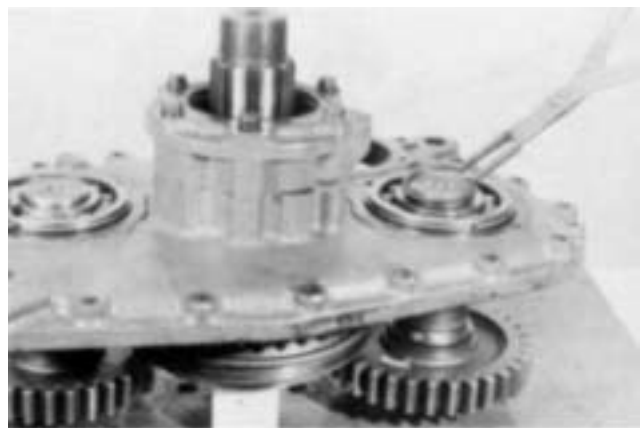

9. Install the snap ring in the rear of each countershaft.

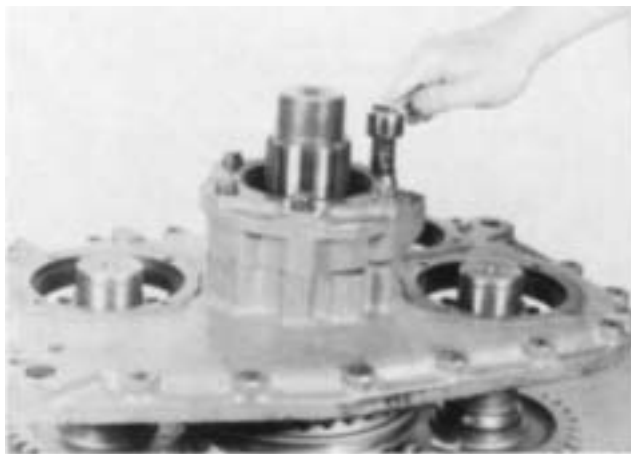

7. If previously removed, install the oil seal in the rear bearing cover and install the cover on the rear housing. The capscrew with the brass washer is installed in the hole intersecting the speedometer bore.



10. Install the rear bearing covers.

D. Installation of the Range Shift Cylinder Assembly

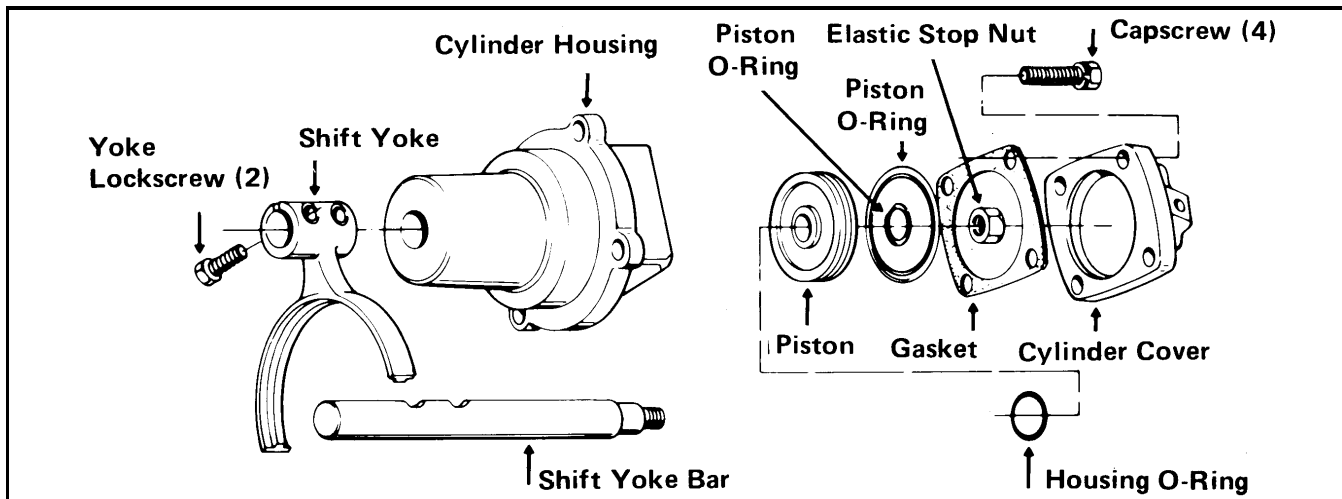

1. Install the housing in a vise in the upright position. Install O-ring in the cylinder bore and secure the housing to the rear housing with four capscrews. The air line fitting is to the top.



3. Install the O-rings in the OD and ID of the piston.



2. Hold the shift yoke in position in the sliding clutch slot, long hub to the front, and insert the yoke bar through the yoke hub and shift cylinder threaded end first. Align the slots in the shaft with the lockscrew bores in the yoke hub. Insert two yoke lockscrews; tighten and wire securely.



4. Install the piston on the bar, flat side out, and secure with the elastic stop nut.



5. Install the shift cylinder cover with the air line fitting to the top left.

11. Auxiliary Section - RT-12510 Series

A. Reassembly of the Output Shaft and Rear Bearing Assembly

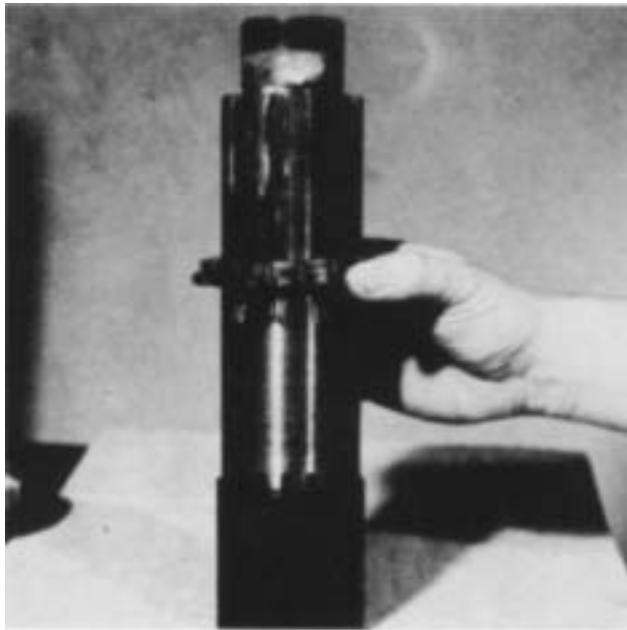
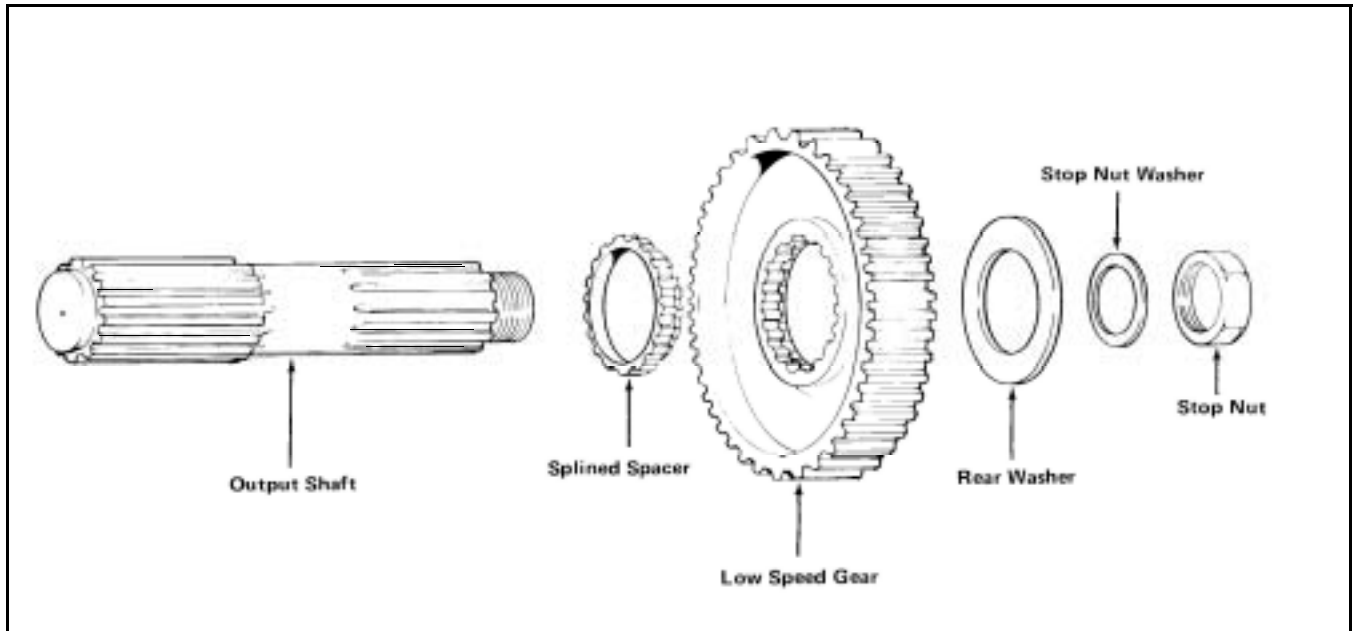

1. Place the output shaft on a bench with the threaded end up and install the splined spacer on the shaft, large diameter down.

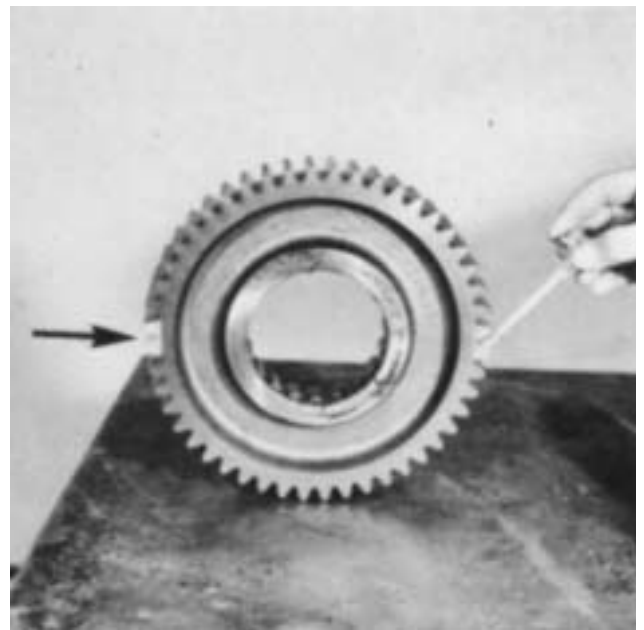

2. Mark any two adjacent teeth on the low speed gear and then mark the two teeth directly opposite.



3. Install the low speed gear on the shaft with the clutching teeth down and engaging the splines of the spacer.

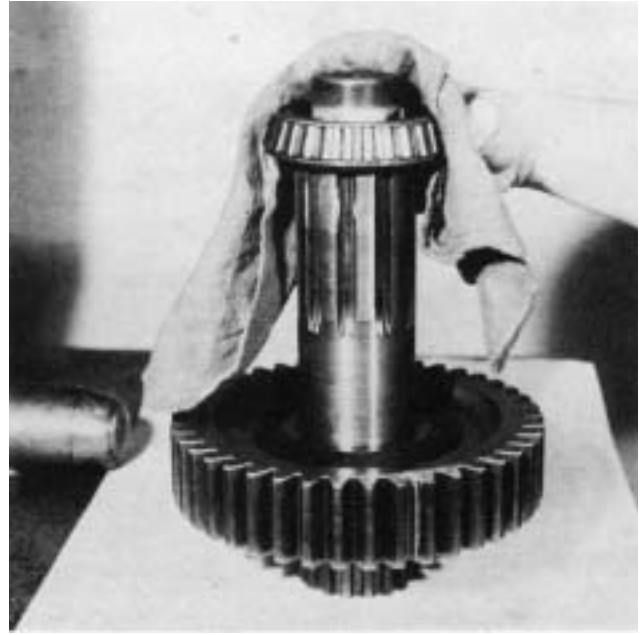

5. Heat and install the front bearing cone on the shaft and against the washer, taper facing up.

NOTE: Heating of the bearing will facilitate installation. Do not heat the bearing over 275°F.

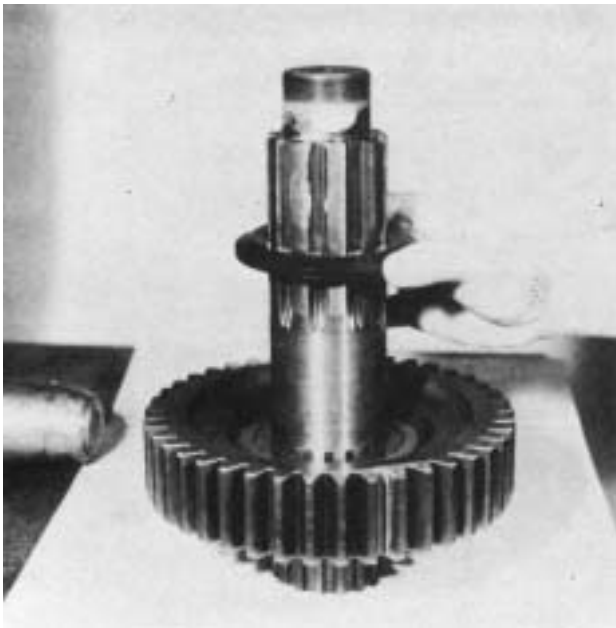

4. Install the washer on the shaft, flat surface down.

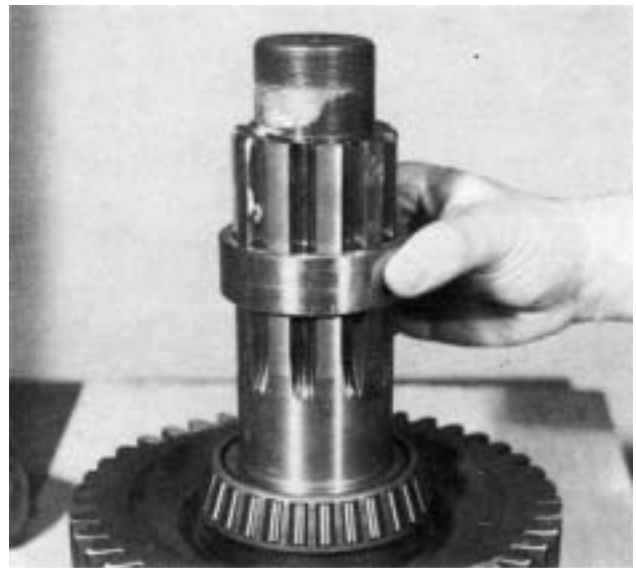

6. Install the bearing inner spacer on the shaft.

A. Reassembly of the Output Shaft and Rear Bearing Assembly - continued

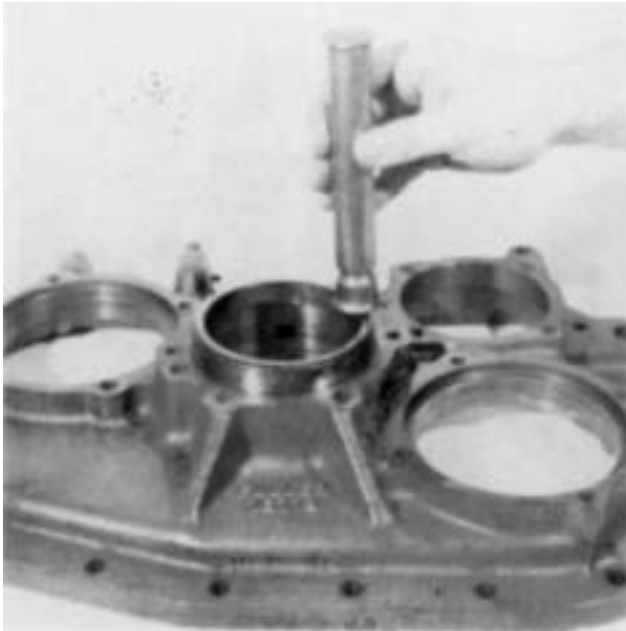

7. Place the front cup of the bearing assembly in the plate bore with the taper to the inside. Tap the cup evenly into the plate with a soft bar.

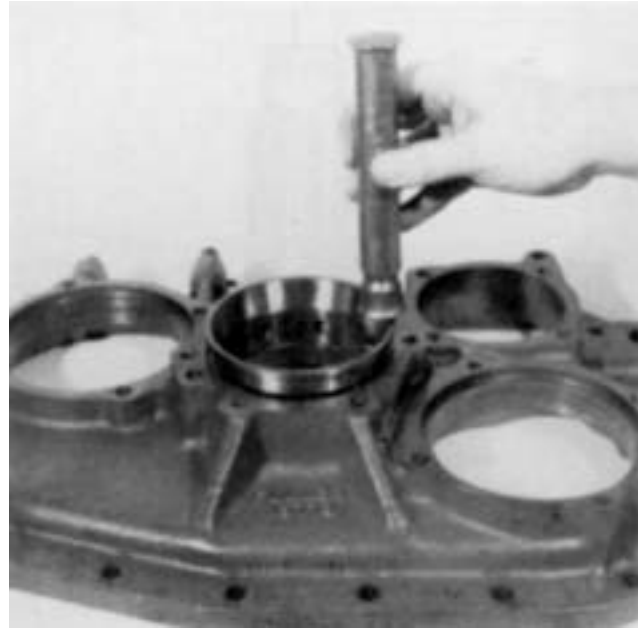

9. Place the bearing rear cup on the outer spacer and evenly tap the cup into the plate bore until the lip of the cup seats against the plate.

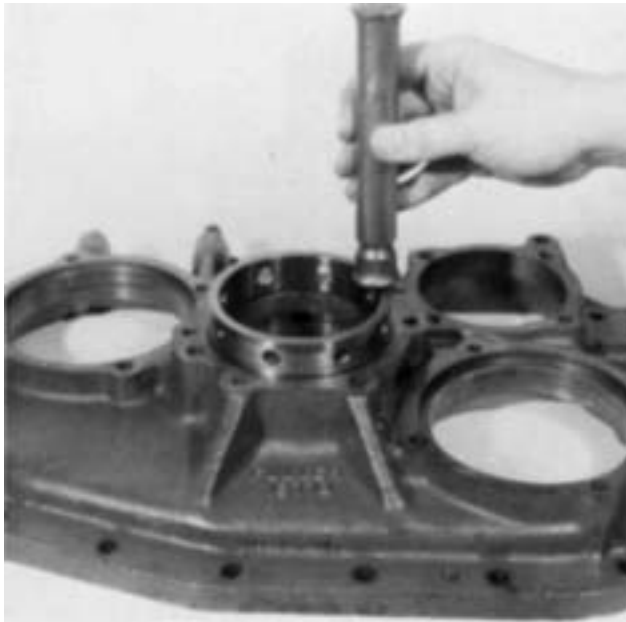

8. Place the outer spacer on the front cup and tap the spacer evenly into the plate bore.



10. Place the rear plate over the output shaft assembly. Use caution to avoid moving the lip of the rear cup away from the plate.



11. Heat and install the rear bearing cone, taper to the reside.

NOTE: Heating of the bearing will facilitate installation. Do not heat the bearing over 275°F.

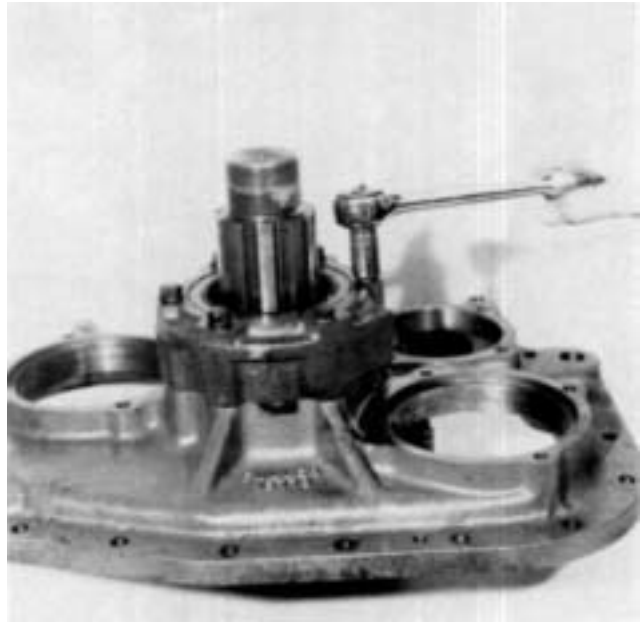

13. Install the rear bearing housing over the output shaft and against the rear plate. If the transmission is equipped with a speedometer drive gear, the gear must be installed on the output shaft prior to installation of the rear bearing housing. Use a brass washer on the cap screw intersecting the speedometer drive gear bore.



12. If previously removed, install the oil seal in the rear bearing housing,

B Reassembly and installation of the Synchronizer Assembly



1. Place the larger (low speed) brass synchronizer ring on a bench with the pins facing up and install the sliding clutch gear over the ring, protruding clutching teeth down.

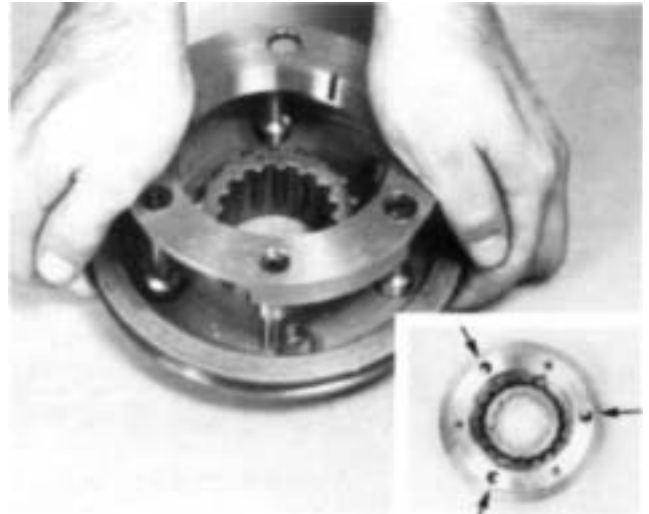

4. Apply pressure to the direct ring while twisting counter-clockwise to fully seat the direct ring on the low speed ring pins.



2. Install the three springs in the direct ring.



3. Install the direct ring on the low speed ring pins, seating the springs against the pins.

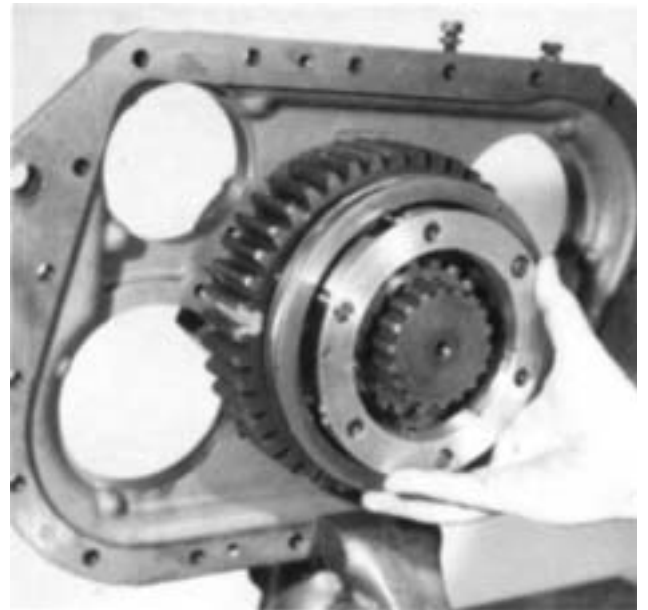

5. Mount the auxiliary plate in a vise in the upright position and install the synchronizer assembly on the output shaft and into the reduction gear bore.

Timing and Installation of the Auxiliary Countershaft Assemblies



1. On the small diameter low range gear of each countershaft, mark the tooth which is stamped with an "O".

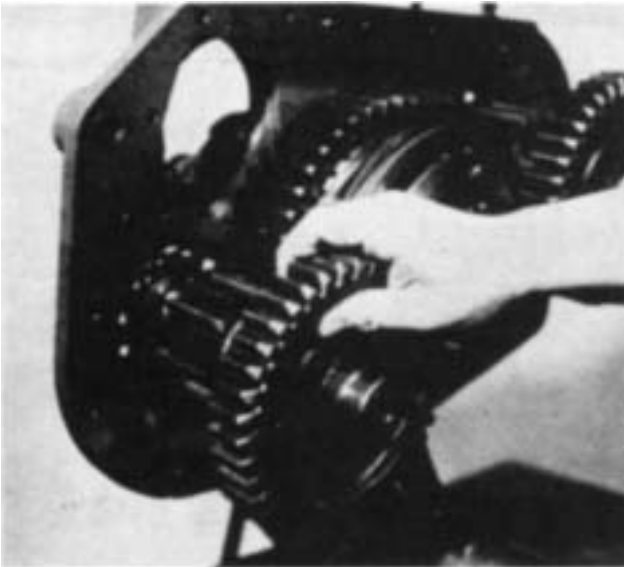

2. Place one of the countershaft into position in the rear plate, meshing the marked tooth on the countershaft between two of the marked teeth on the low speed gear. Use a soft bar to start the rear bearing on to the shaft and into the case bore and use a bearing driver to complete the installation. Check the synchronizer assembly during bearing installation to make sure that the springs do not pop out. Repeat the procedure for the remaining countershaft.

NOTE: Make sure that the bearing inner race is installed on the front of each auxiliary countershaft.

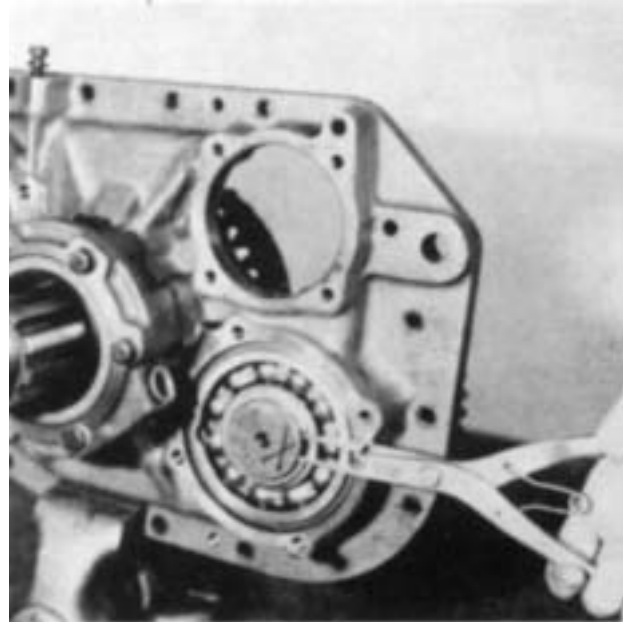

3. Install the snap ring on the rear of each countershaft.

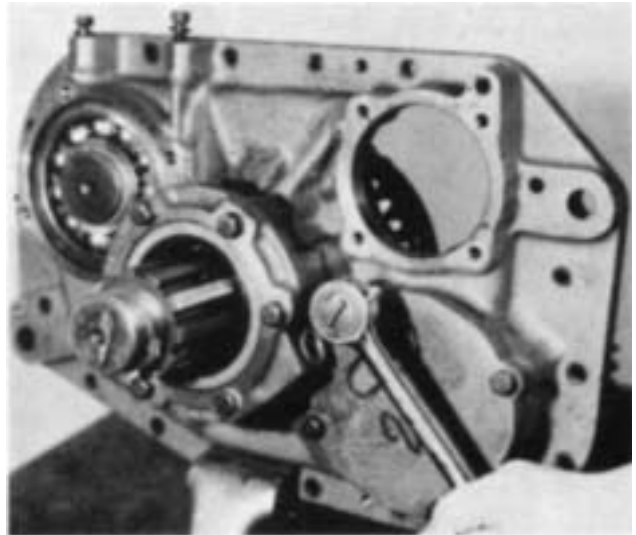

4. Install the countershaft rear bearing covers.

D. Installation of the Range Shift Cylinder Assembly

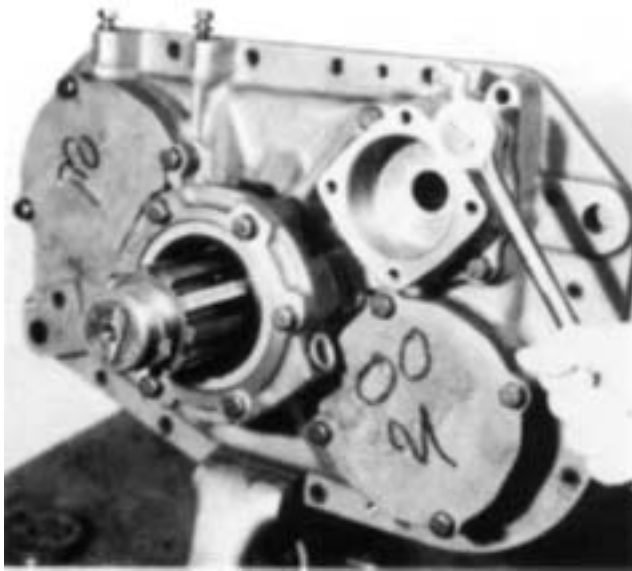

1. If previously removed, install the O-ring in the bore of the cylinder housing and install the housing in the rear plate bore, air fitting to the top right. Secure with the four capscrews.

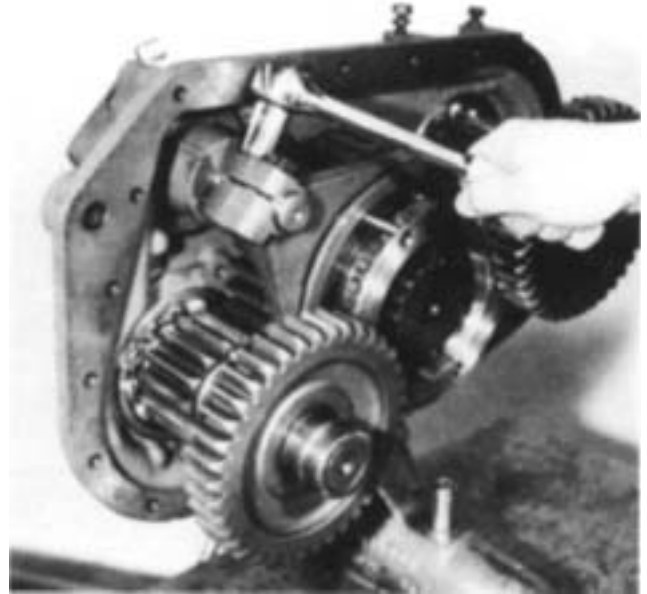

3. Insert the two yoke lock screws; tighten and wire securely.

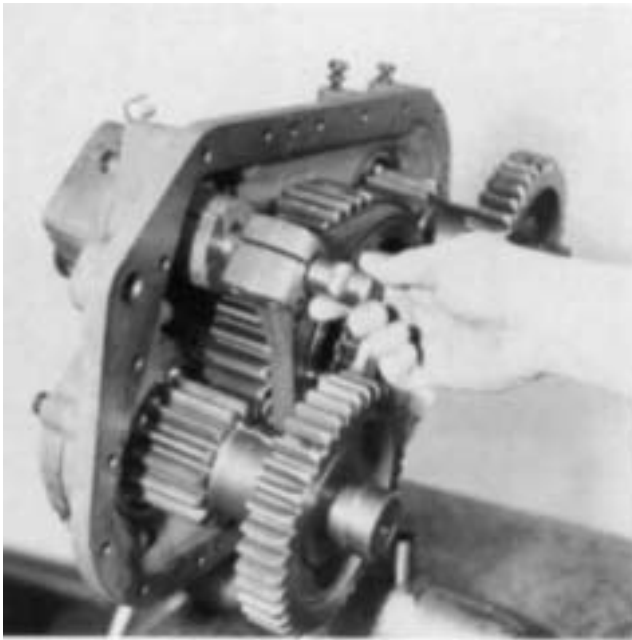

2. Hold the shift yoke in position in the synchronizer sliding clutch gear with the long hub of the yoke to the rear and insert the yoke bar through the yoke and cylinder housing, aligning the notches in the bar with the yoke lock screw bores.



4. If previously removed, install the O-rings in the OD and ID of the piston.

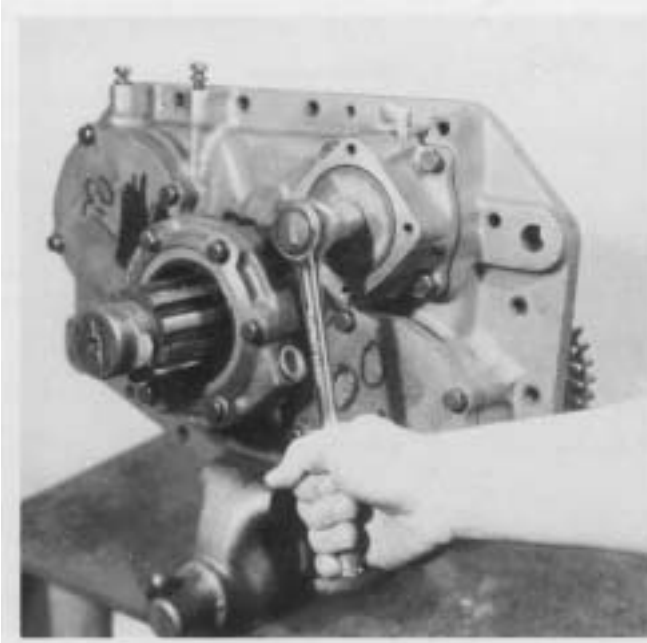

5. Install the piston on the bar, flat side out and secure with the elastic stop nut.



6. Install the shift cylinder cover on the housing with the air fitting to the top left.

III. Auxiliary Section - RT-12515 Series

A. Reassembly of the Output Shaft and Rear Bearing Assembly

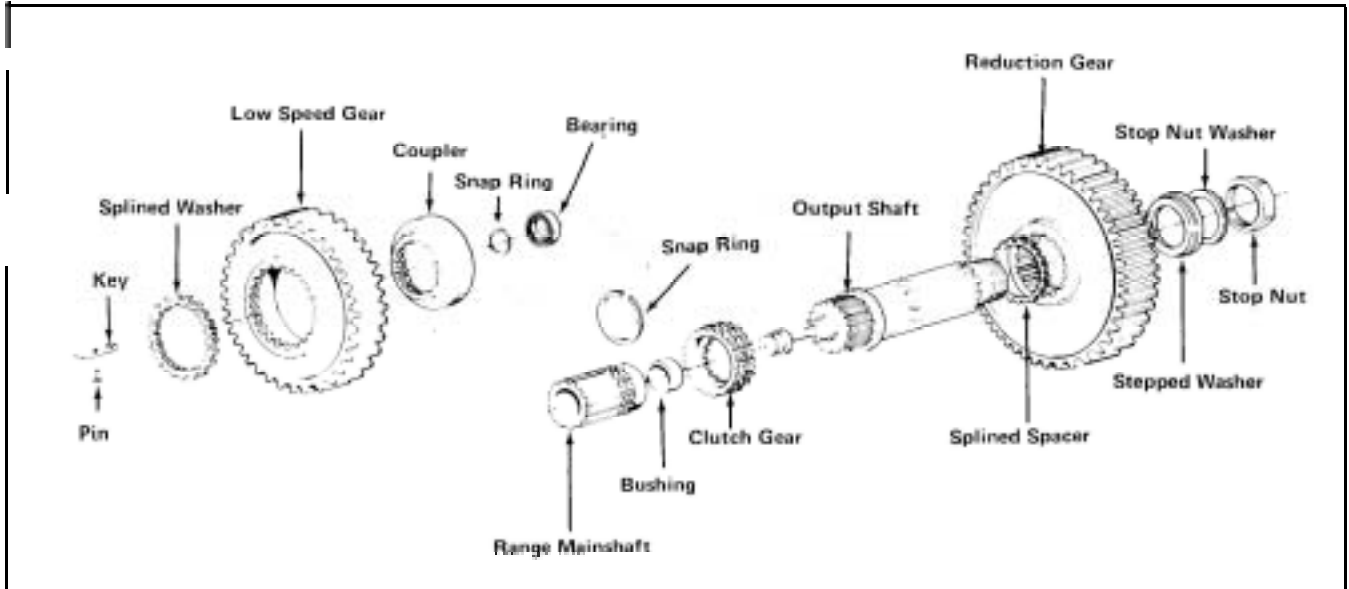

1. Place the output shaft on blocking with the threaded end up. Use caution to avoid damage to the quill.



2. Install the splined spacer on the shaft.

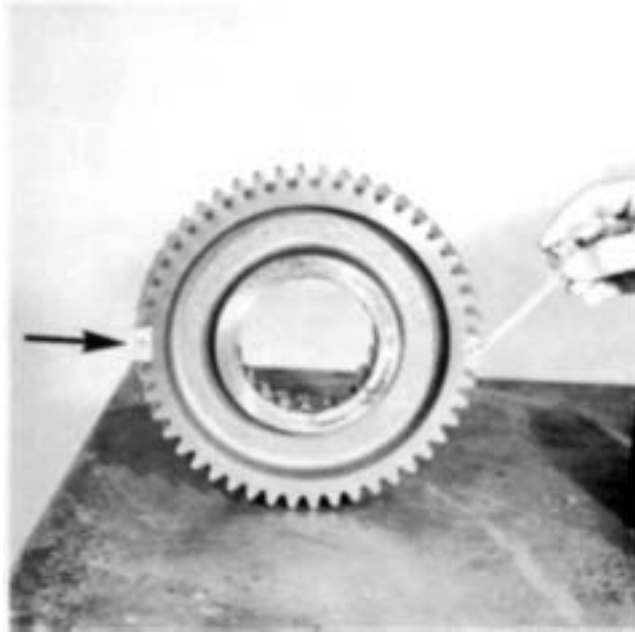

3. Mark any two adjacent teeth on the reduction gear and then mark the two teeth directly opposite.



5. Install the washer on the shaft and against the gear with the side with the large groove facing up.



4. Install the reduction gear on the shaft and spacer with the clutching teeth down.



6. Install the oil deflector in the rear housing bore with the cupped surface facing up. Use a large bearing driver to drive the deflector down until the top surface of the deflector is 2" below the machined surface of the output shaft bore.

NOTE: If available, use two bearing outer spacers stacked on top of each other to drive the oil deflector into the bore. The deflector will be at the proper depth when the top of the top spacer is flush with the machined surface of the output shaft bore.

A. Reassembly of the Output Shaft Assembly - continued

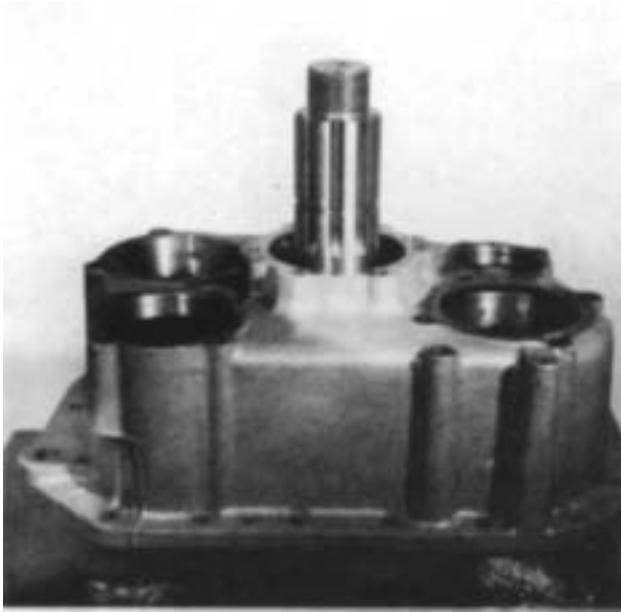

7. Install the rear housing over the output shaft, allowing the housing to rest on the reduction gear.



9. Install the bearing inner spacer on the shaft and against the front bearing cone.

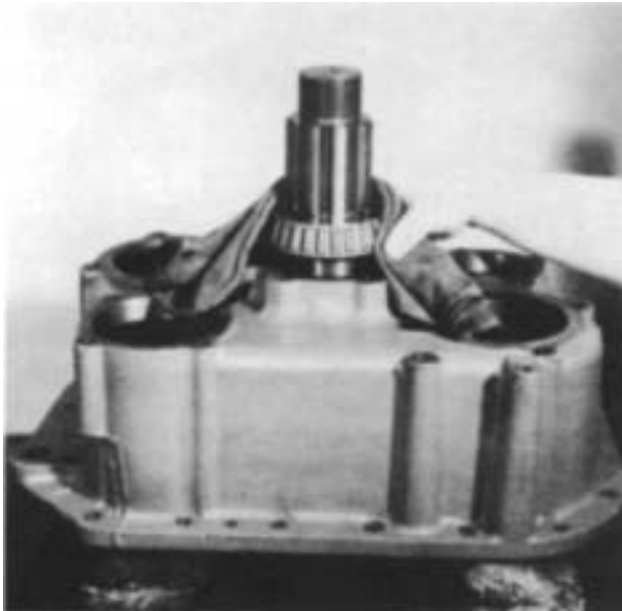

8. Heat the front bearing cone and install in the bore and against the oil deflector with the cone surface facing up.
NOTE: Heating of the bearings will facilitate installation. Do not heat the bearings over 275°F.

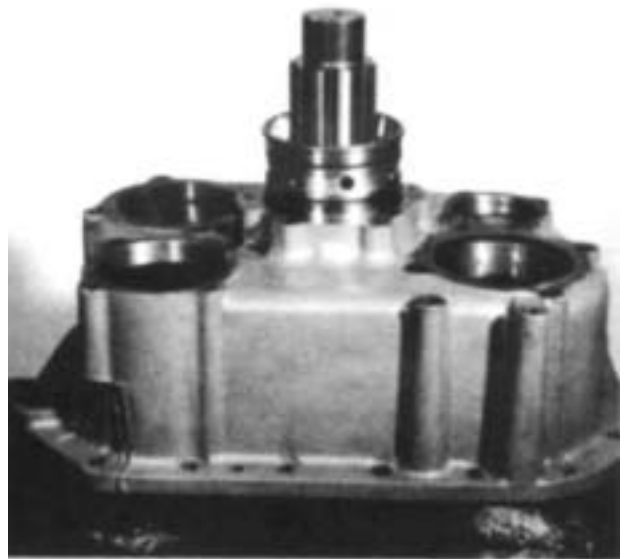

10. Stack the two bearing cups and outer spacer in the output shaft bore in the proper sequence. Make sure that the front bearing cup taper matches the taper direction of the front bearing cone.

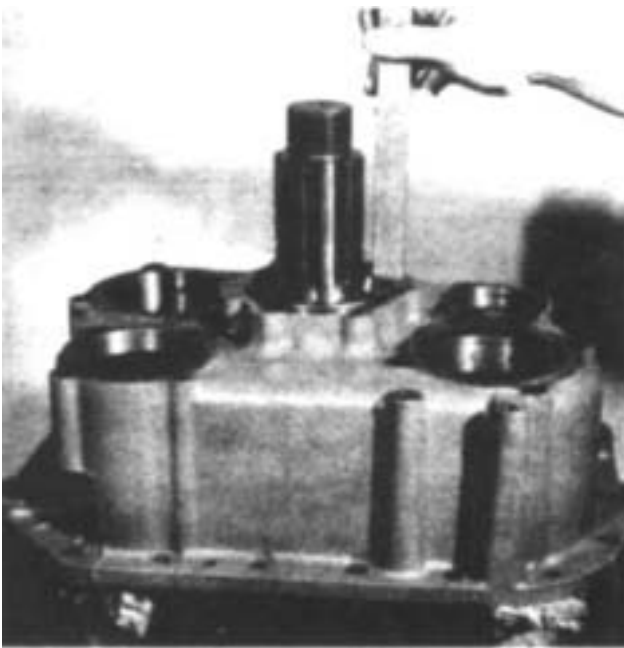

11. Tap the two cups and outer spacer lightly and evenly into the case bore until the lip of the rear cup seats against the machined surface. It will be necessary to block under the rear housing slightly to permit the output shaft assembly to move far enough.

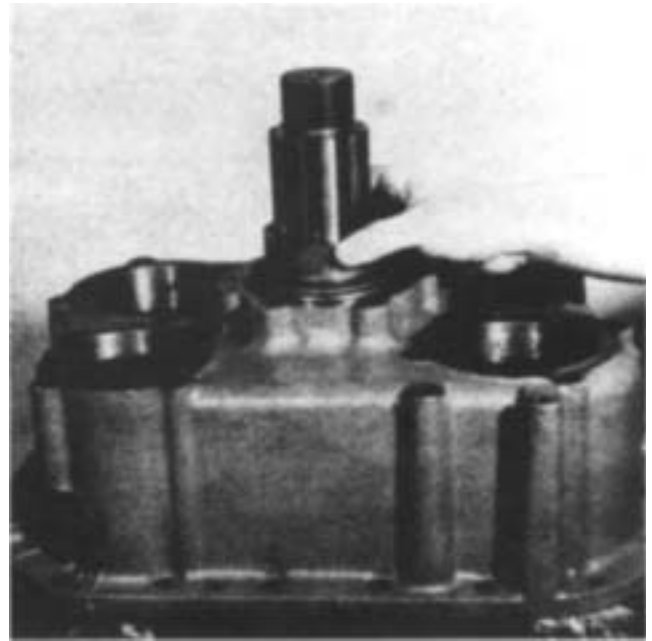

13. Install the speedometer drive gear or replacement spacer on the shaft and against the rear bearing cone.

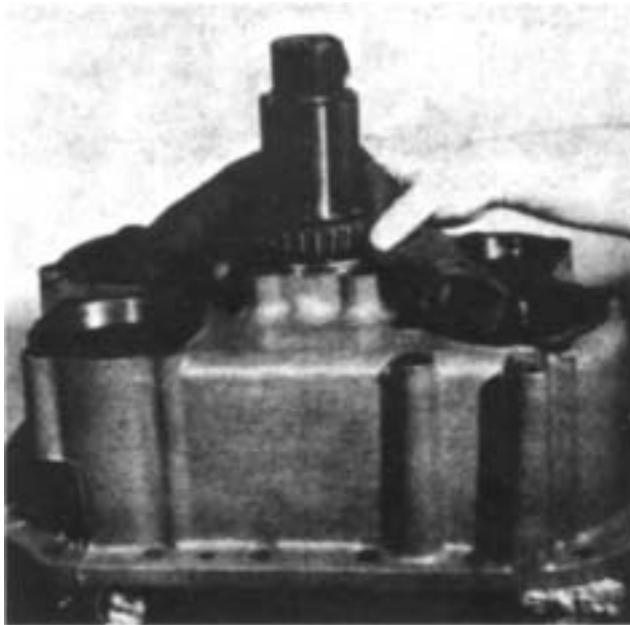

12. Heat and install the rear bearing cone on the shaft and in the rear cup, taper facing down.

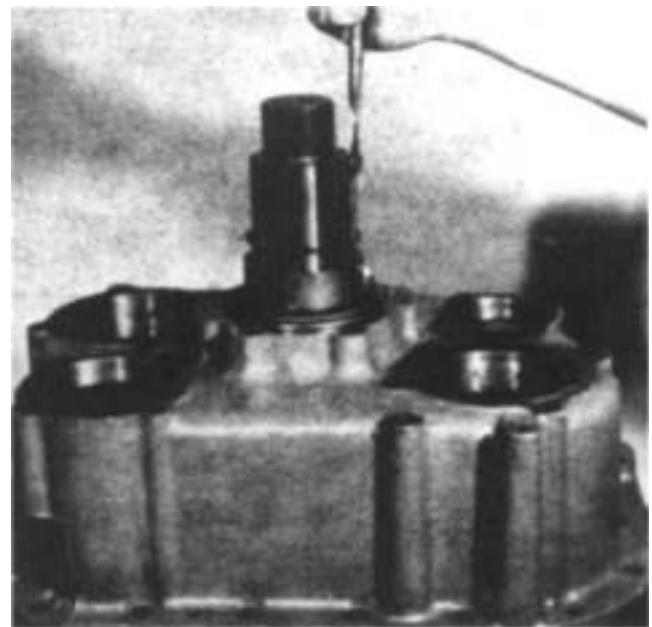

14. Install the snap ring in the output shaft groove.

A. Reassembly of the Output Shaft Assembly - continued



15. If previously removed, install the oil seal in the rear bearing housing with the side of the seal with the seam facing into the housing.



16. Install the rear bearing housing on the auxiliary housing, making sure that the oil port in the auxiliary housing aligns with the notch in the bearing housing. Use a brass washer on the capscrew intersecting the speedometer drive bore.

B. Installation of the Range Mainshaft Assembly

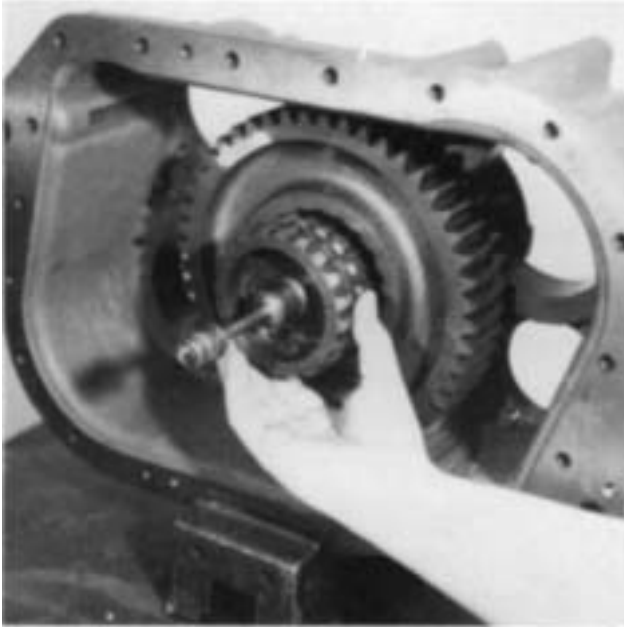

1. Install the clutch gear on the shaft, internal clutching teeth to the rear.

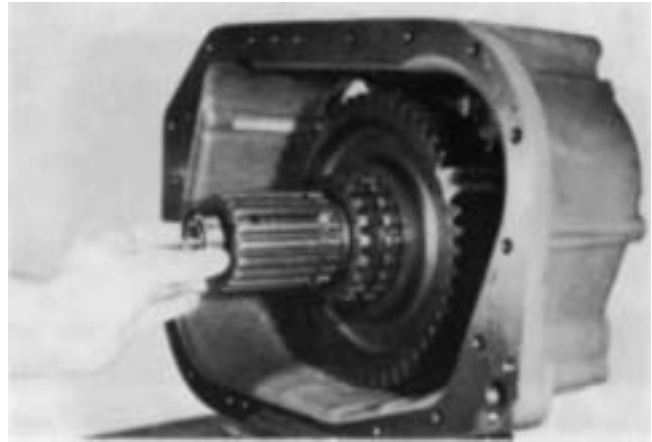

3. Install the range mainshaft on the output shaft quill.

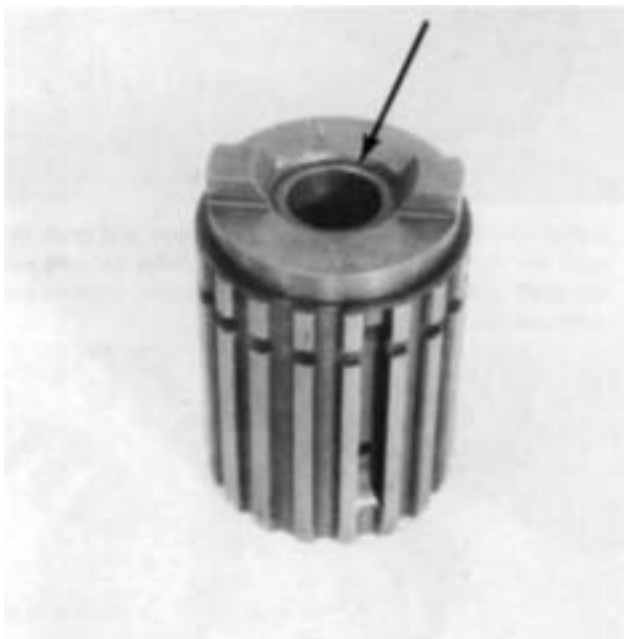

2. If previously removed, install the snap ring on the range mainshaft. Check the bushing in the pocket of the mainshaft for wear. Replace if defective.

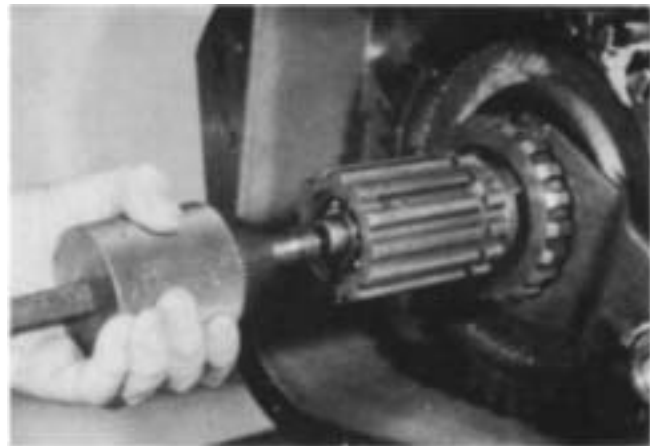

4. Install the bearing on the quill and in the range mainshaft.

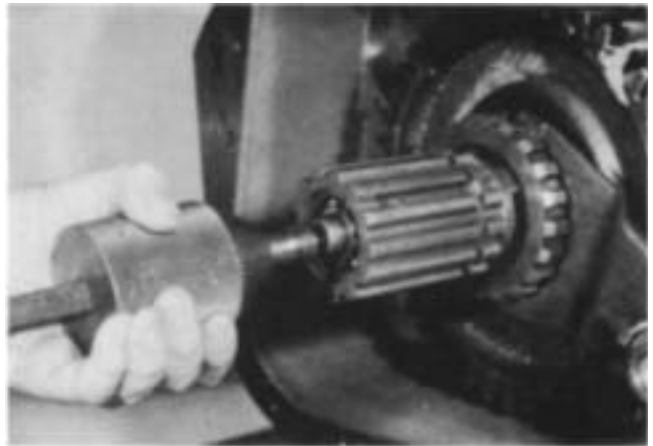

5. Secure the bearing with the snap ring.

C. Reassembly and Installation of the Deep Reduction Shift Cylinder

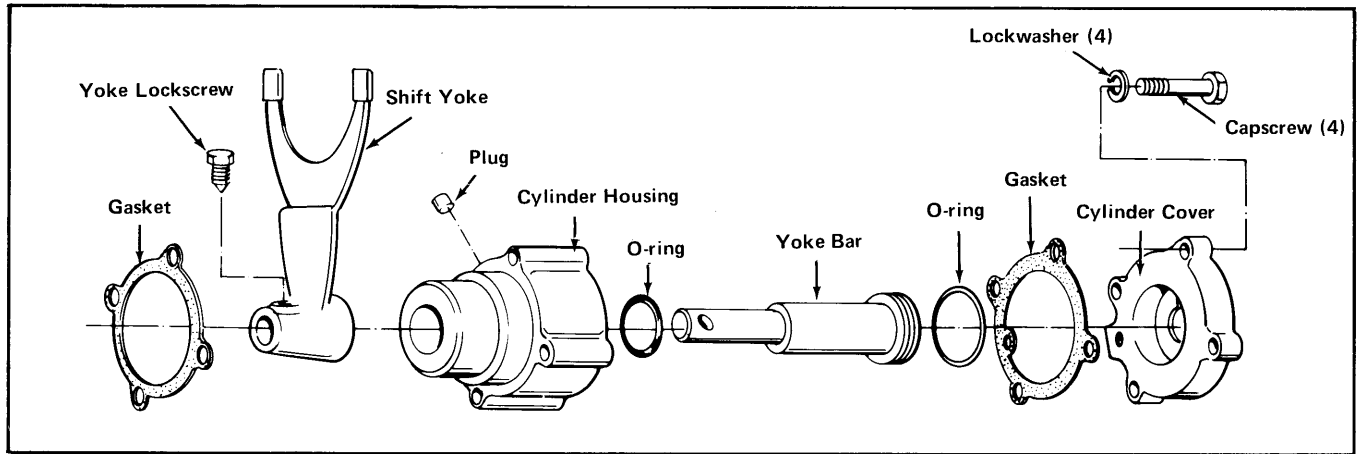

1. Install an O-ring in the bore of the shift cylinder and install the cylinder in the auxiliary housing with the air channel to the right.



3. Install the O-ring in the yoke bar groove and push the yoke bar forward and through the cylinder housing and the shift yoke. Install the yoke lockscrew; tighten and wire securely.



2. Install the yoke in the sliding clutch yoke slot with the lockscrew hole facing up.



4. Install the cylinder cover, aligning the air channel with the channel in the cylinder housing.

D. Installation of the Low Range Gear

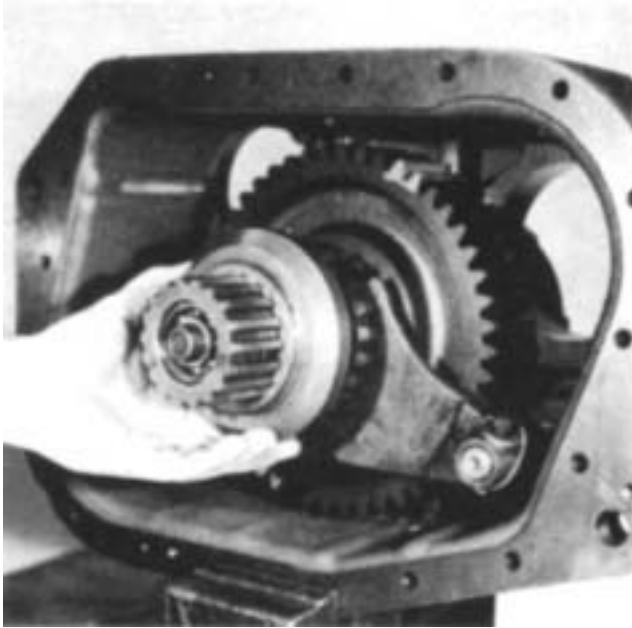

1. Install the coupler on the shaft, large diameter to the rear.



3. Install the splined washer on the shaft and in the hub of the gear. Turn the washer to lock the gear on the shaft.

NOTE: Splined washers with varying thicknesses are available. Use the washer that provides the tightest fit in the hub of the gear.

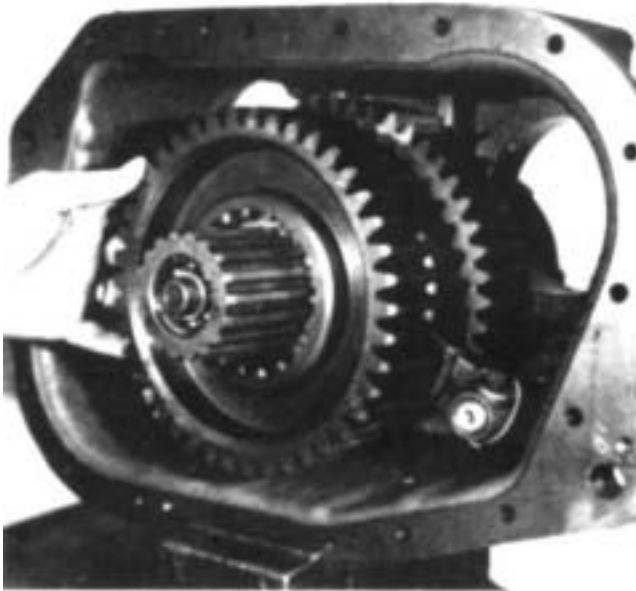

2. Mark any two adjacent teeth on the low range gear and then mark the two teeth directly opposite. Install the gear on the shaft and against the coupler with the dished side facing to the front.

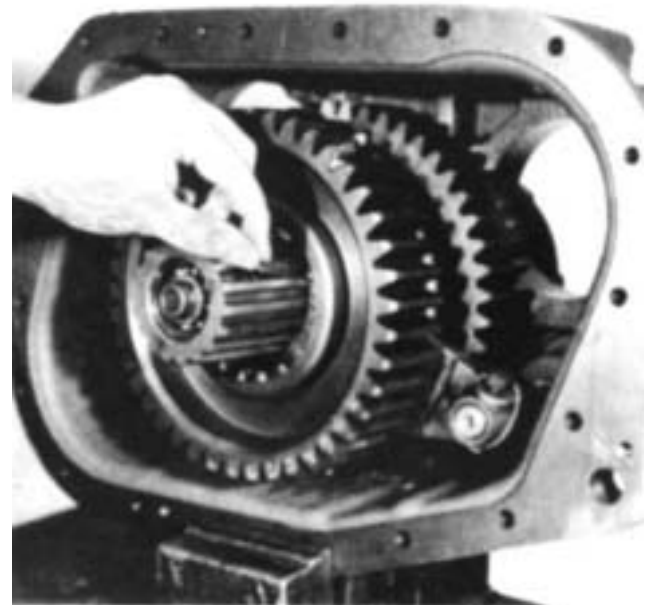

4. Install the key in the keyway, inserting the thick end between the splines of the washer.

E. Reassembly and Installation of the Synchronizer Assembly

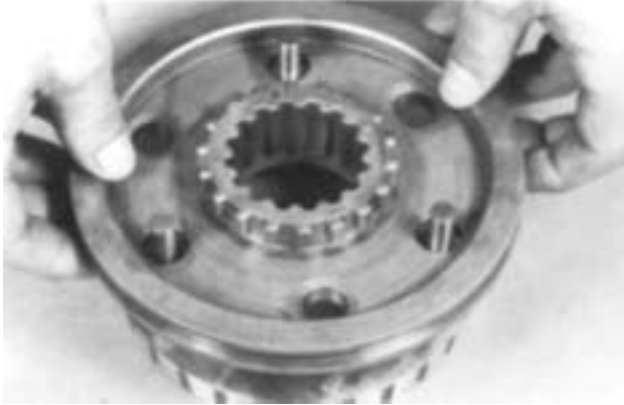

1. Place the larger low speed ring on the bench with the pins upward and install the sliding clutch on the ring, protruding clutching teeth down.

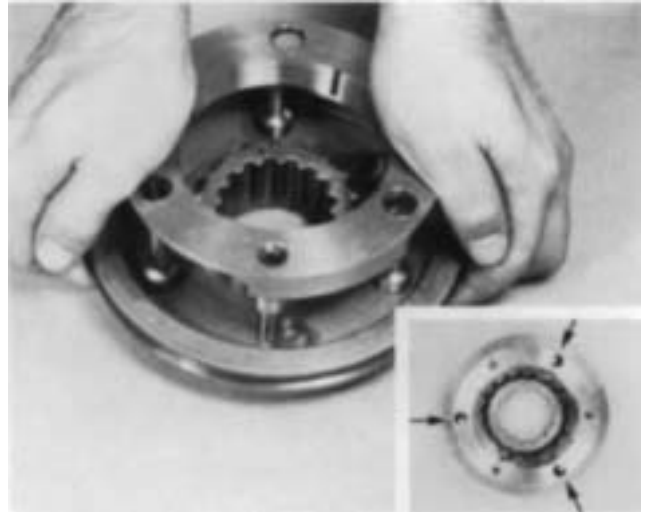

4. Apply pressure to the direct ring while twisting counter-clockwise to fully seat the direct ring on the low speed ring pins.



2. Install the three springs in the direct ring.

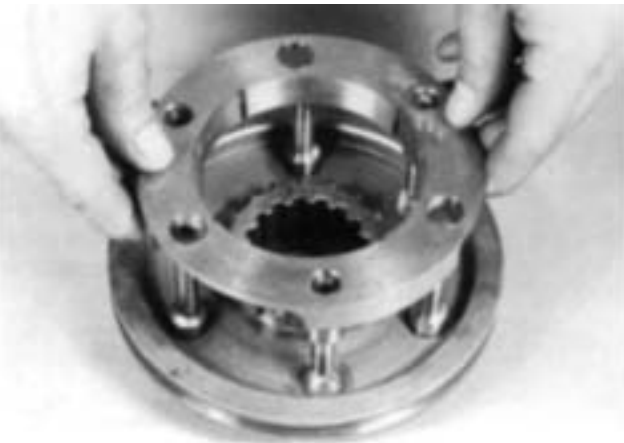

3. Install the direct ring on the low speed ring pins, seating the springs against the pins.

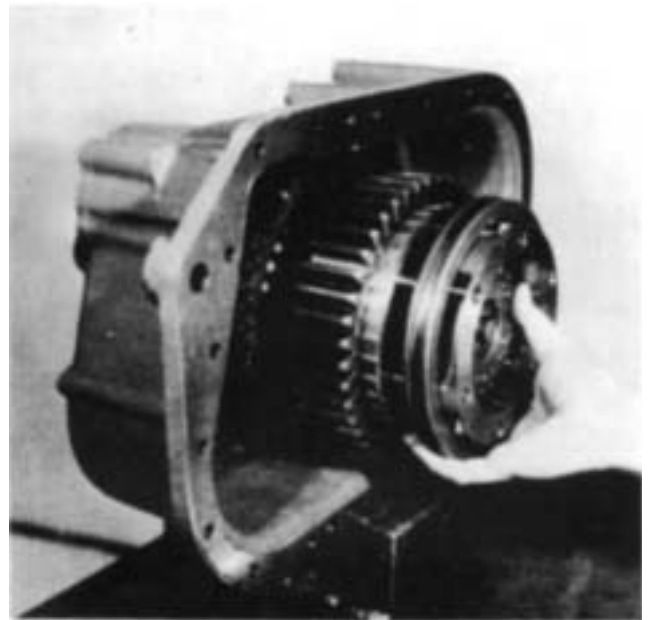

5. Install the synchronizer assembly on the splines of the output shaft and in the hub of the low speed gear.

F. Timing and Installation of the Auxiliary Countershaft Assemblies

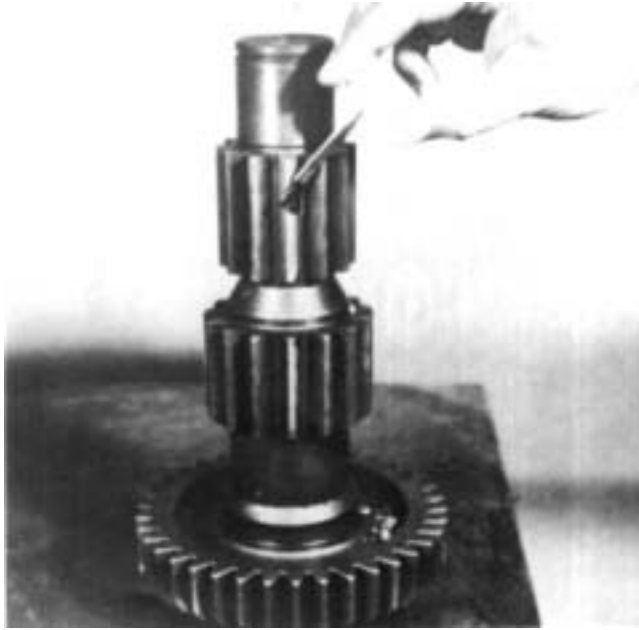

1. Mark the tooth which is stamped with an "O" on each of the three sets of gears on the auxiliary countershaft.

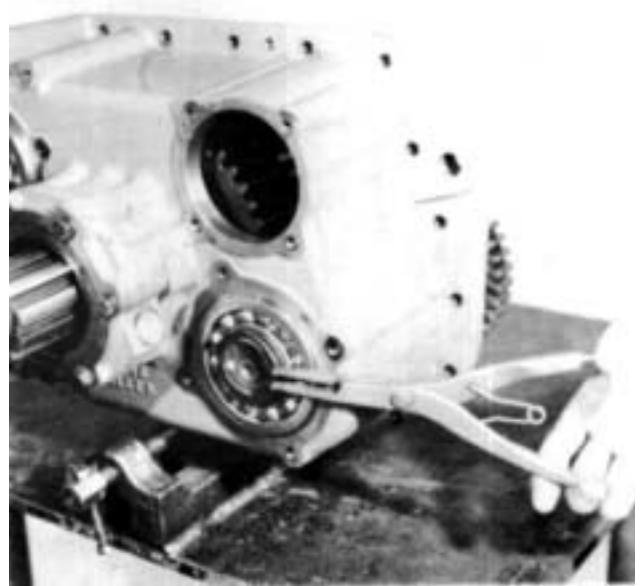

3. Install the snap ring in the groove on the rear of each countershaft.

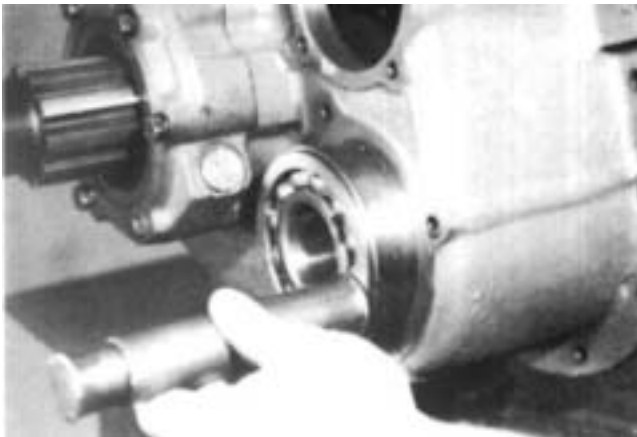

2. Place one of the countershaft into position in the case, meshing the marked teeth on the shaft between one of the sets of marked teeth on each of the gears. Hold the countershaft in position and use a soft bar to tap the rear bearing on to the shaft and into the case bore. Use a bearing driver to complete installation of the bearing. Check the synchronizer during bearing installation to make sure that the springs do not pop out. Repeat the procedure to install the remaining countershaft.

IMPORTANT: Make sure that the bearing inner race is installed on the front of each countershaft.

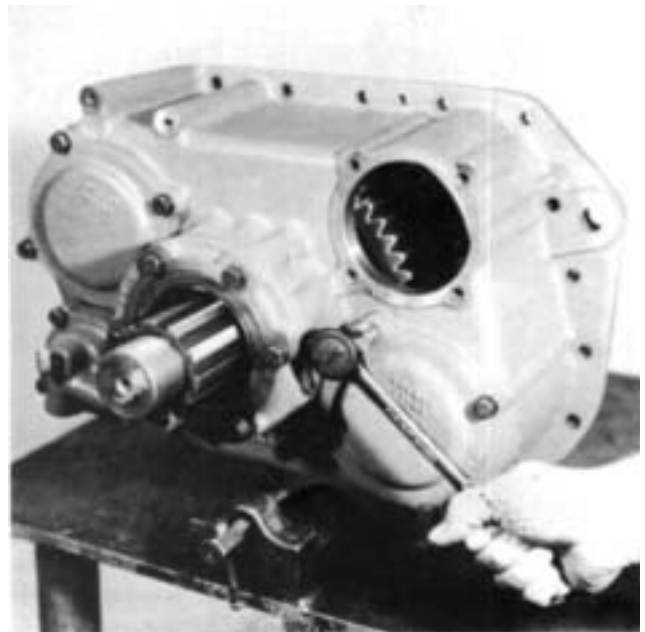

4. Install the two rear bearing covers.

G. Reassembly and Installation of the Range Shift Cylinder

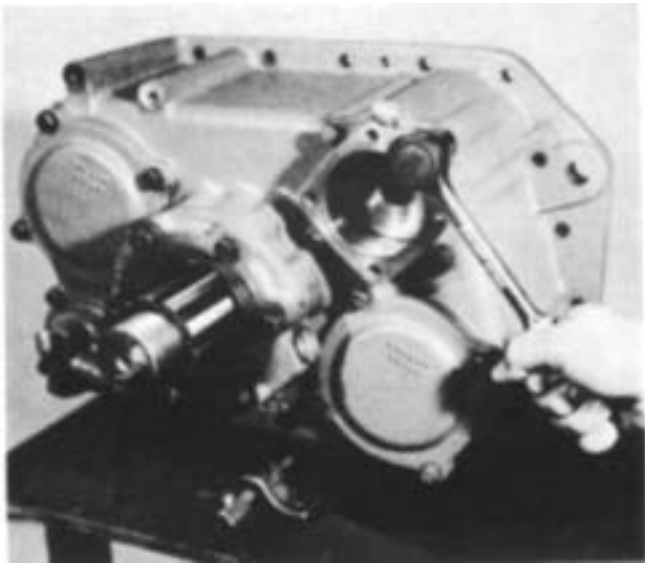
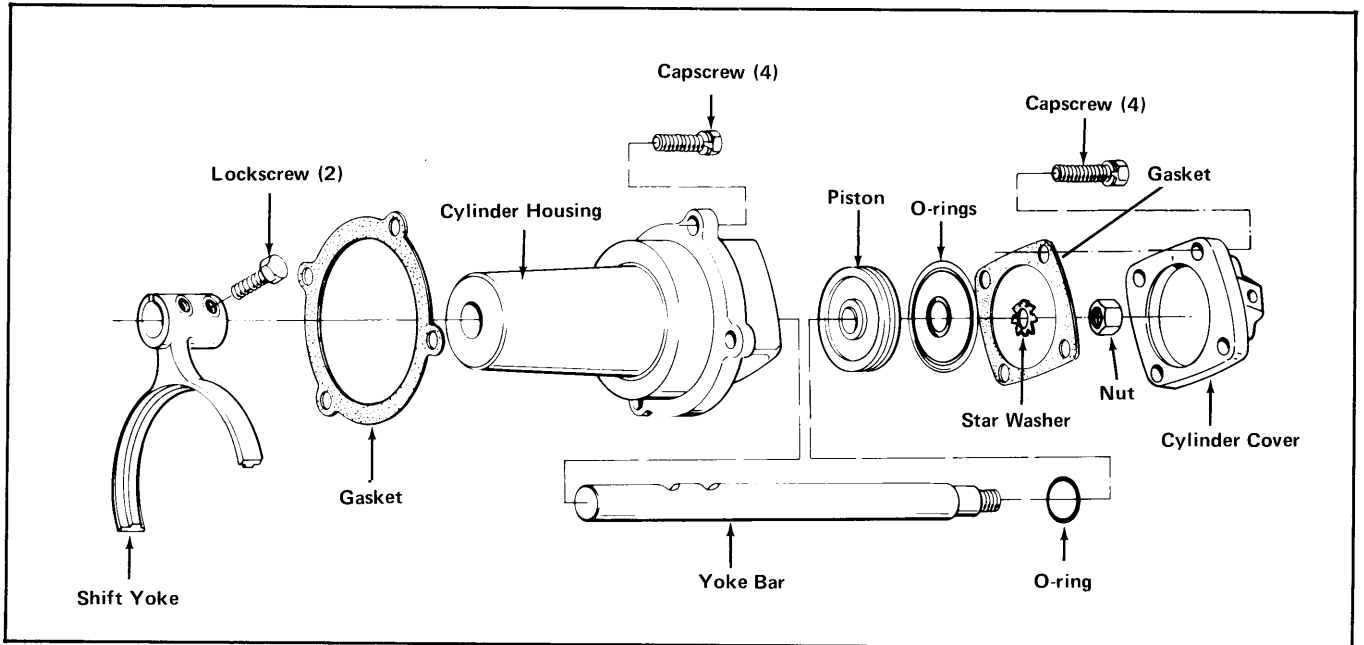

1. Install the O-ring in the bore of the shift cylinder and install the cylinder housing in the rear housing with the air line fitting to the top.

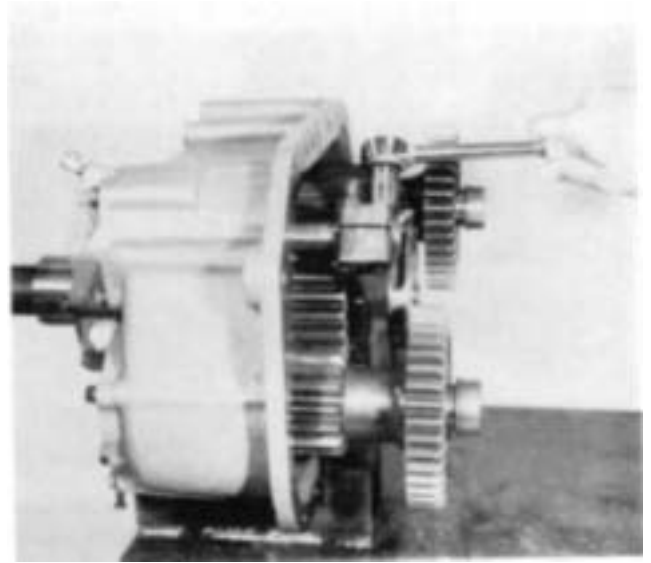

2. Hold the shift yoke in position on the sliding clutch with the long hub of the yoke to the rear and insert the yoke bar through the hub and shift cylinder, aligning the slots in the bar with the lockscrew bores in the yoke hub. Install the two yoke lockscrews; tighten and wire securely.



3. Install the O-rings in the O D and ID of the piston.

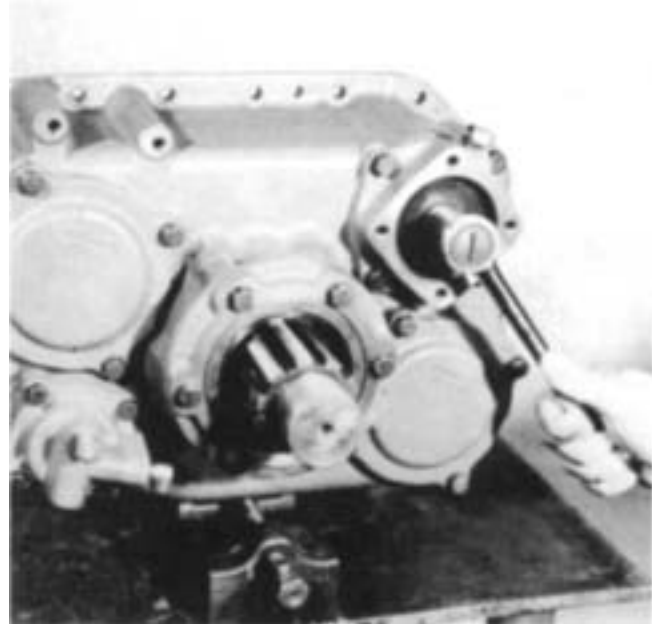

5. Install the elastic stop nut on the bar and tighten securely.

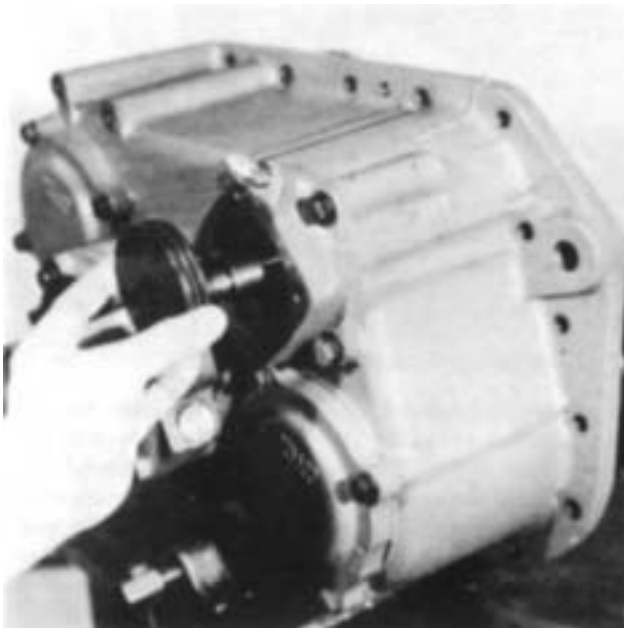

4. Install the piston on the bar with the flat face out.

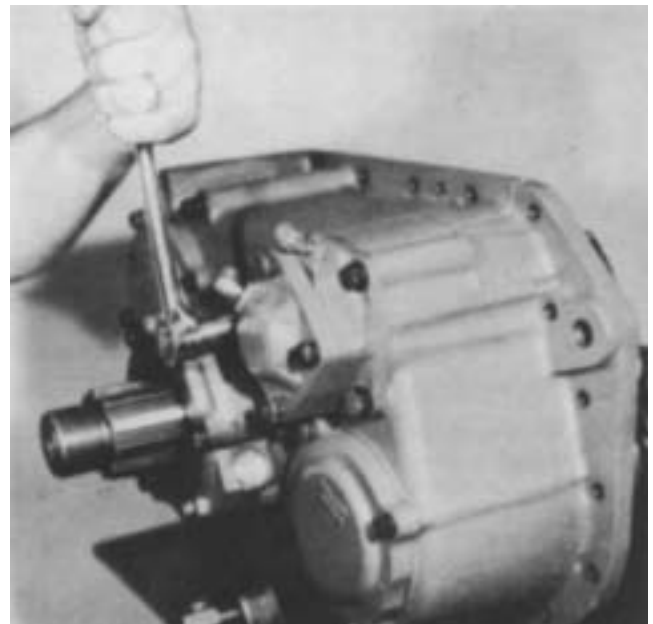

6. Install the cover on the shift cylinder with the air fitting to the top left.

IV. Front Section

A. Reassembly and Installation of the Right Reverse Idler Gear Assembly

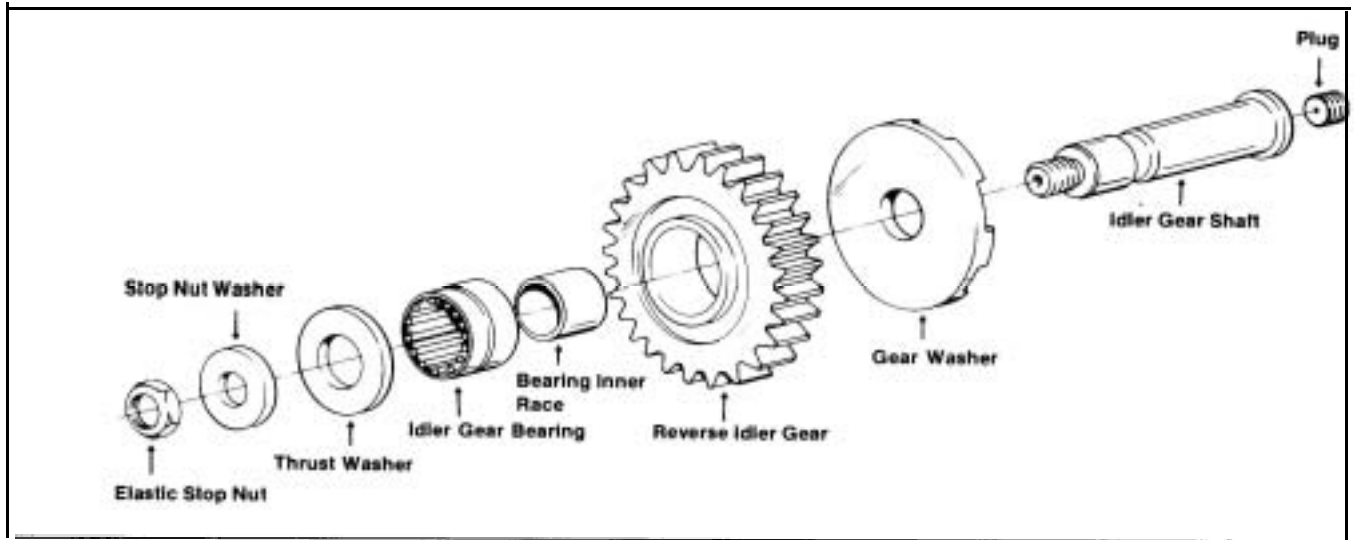

NOTE: Check to make sure that the three magnetic discs are solidly in place in the bottom of the case. These can be installed with "3M Brand" adhesive, No. EC 1300.



1. Install the plug in the end of the reverse idler shaft and install the idler gear washer on the shaft. If previously removed, press the needle bearing into the bore of the idler gear.

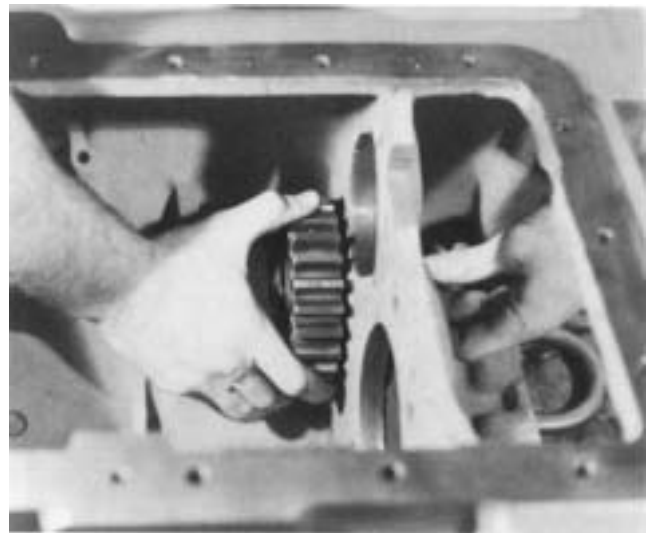

2. If previously removed, install the bearing inner race on the shaft and insert the shaft, threaded end first into the lower right wall of the case. As the shaft is moved forward, install the reverse idler gear and thrust washer on the shaft, making sure that the long hub on the idler gear is facing towards the front of the case. The thrust washer is installed between the front of the gear and the housing boss.

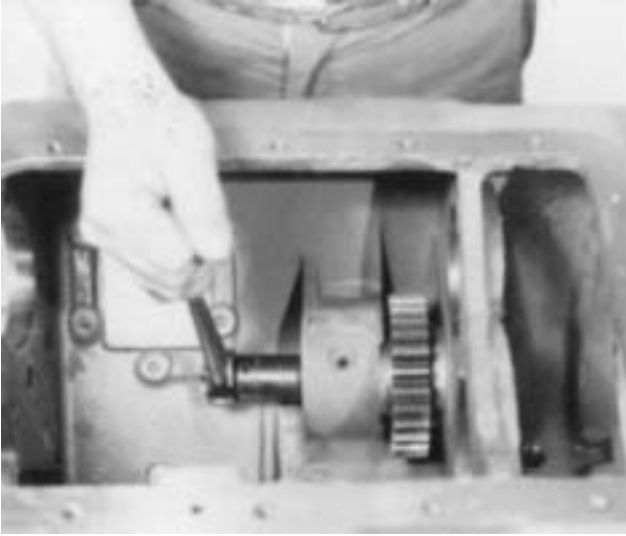

3. Seat the shaft securely in the bore, making sure that the needle bearings are positioned properly on the inner race before moving the shaft forward. Secure the shaft with the washer and elastic stop nut. Tighten to recommended torque.

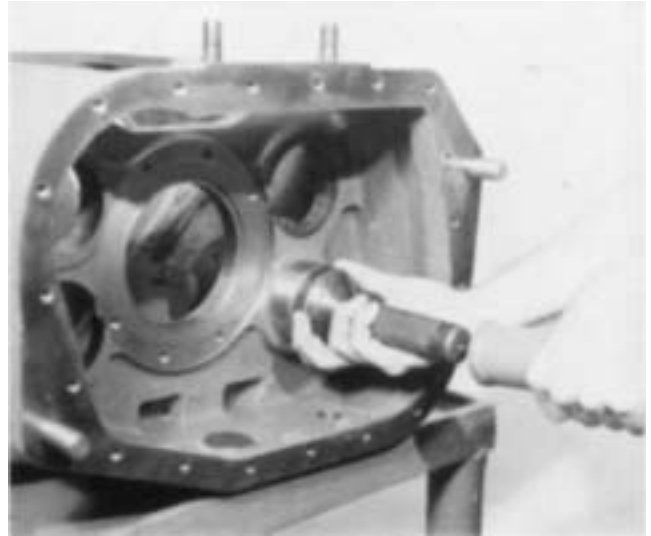

4. Install the auxiliary countershaft front bearing in the bore with a bearing driver.

Reassembly — Front Section

B. Reassembly of the Countershaft Assemblies

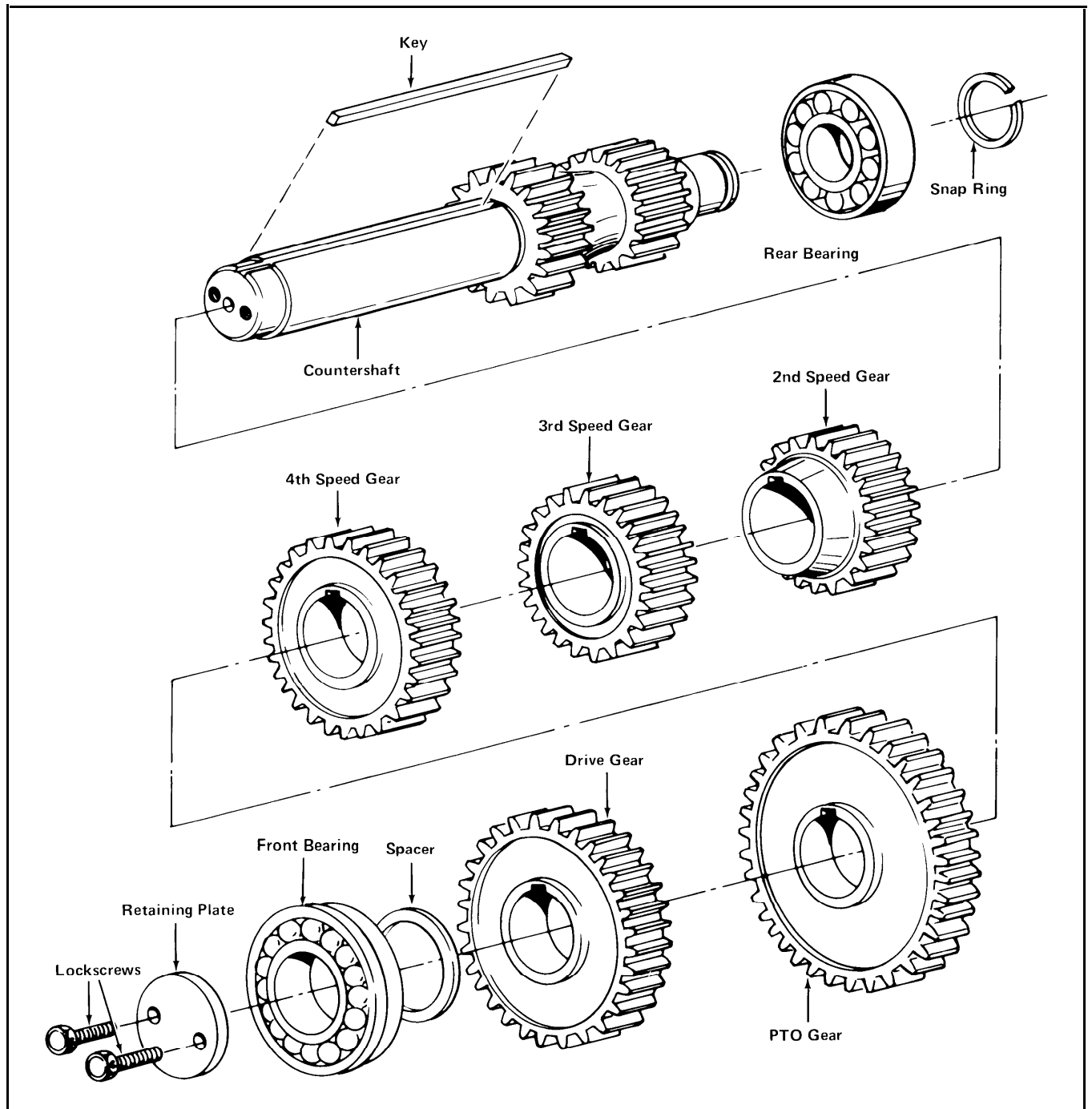

NOTE: Except for the number of teeth on the PTO gears, the countershaft are identical and assembled in the same manner.

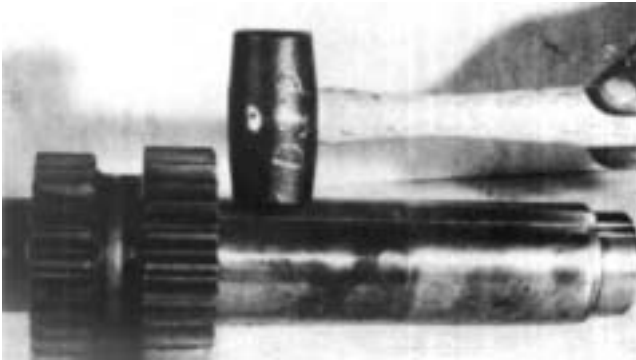

1. If previously removed, install the key in the keyway with the beveled end of the key away from the gears.

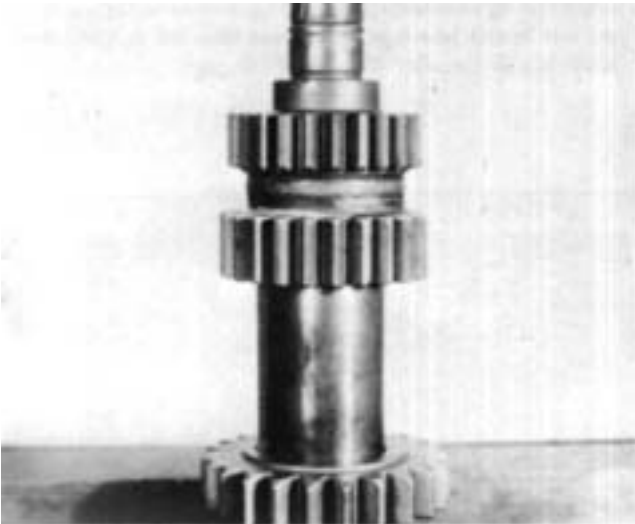

2. Press the 2nd speed gear on to the shaft with the long hub of the gear facing down.

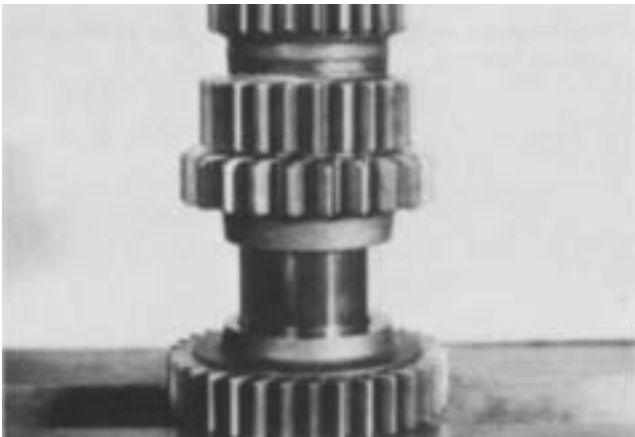

3. Press the 3rd speed gear on to the shaft with the long hub of the gear facing up.



4. Press the 4th speed or O/D gear onto the shaft with the long hub of the gear facing down.



5. Start the PTO gear on to the shaft with the rounded side of the teeth facing up. Install the drive gear on the shaft with the long hub facing up and press the PTO and drive gears into position. Install the spacer on the shaft next to the drive gear.

C. Timing and Installation of the Countershaft Assemblies

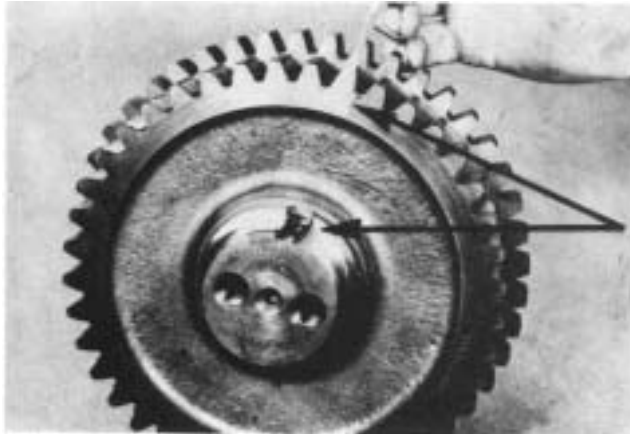

1. On the drive gear of each countershaft, mark the gear tooth which aligns with the keyway in the shaft. This tooth will be stamped with an "O".

NOTE: The left-side countershaft takes a 47-tooth PTO gear; the right side countershaft takes a 45-tooth PTO gear.

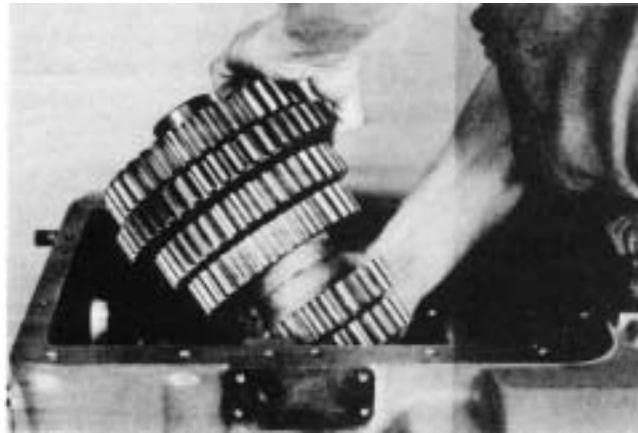

2. Place the left countershaft into position in the case, but do not install bearings. Make sure the left countershaft has the larger 47-tooth PTO gear.



3. Place the right countershaft into position in the case, but do not install bearings. Make sure that the right countershaft has the smaller 45-tooth PTO gear.

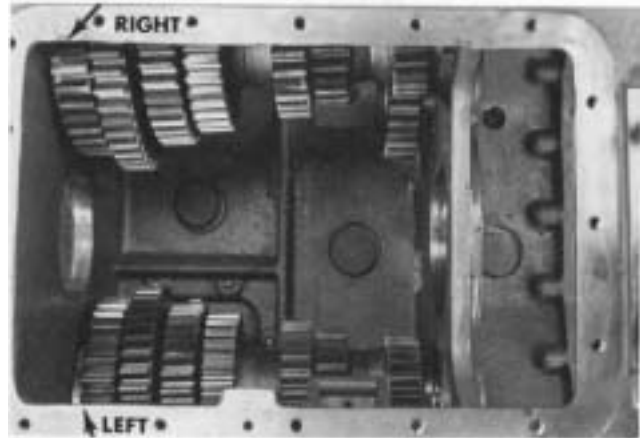

4. Countershafts will now be in approximate position but without bearings.

D. Reassembly of the Drive Gear Assembly



1. Install the snap ring in the groove in the ID of the drive gear.

NOTE: Make sure that the busing is installed in the pocket of the input shaft.

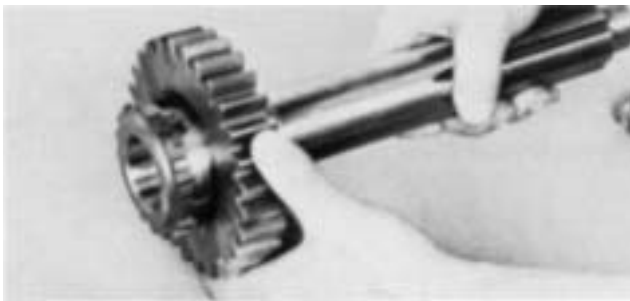

2. Install the drive gear on the shaft, engaging the internal splines of the gear with the teeth on the shaft, snap ring of gear towards the front.



3. Install the drive gear spacer on the shaft and against the gear.



4. Press the drive gear bearing on the shaft with the shield to the front.



5. Apply Grade AV Loctite to the threads of the shaft and nut.

Reassembly — Front Section

D. Reassembly of the Drive Gear Assembly - continued

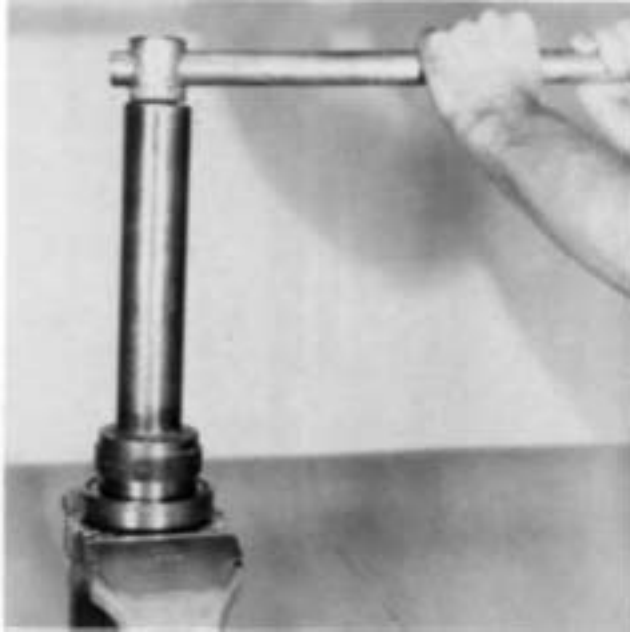

6. Install the bearing nut on the shaft with 250-300 ft. lbs. of torque.



7. Peen the nut into the two milled slots of the shaft.

NOTE: To hasten hardening of the Loctite, place the assembly under heat lamps 10 to 15 minutes.

E. Timing and Installation of the Drive Gear Assembly

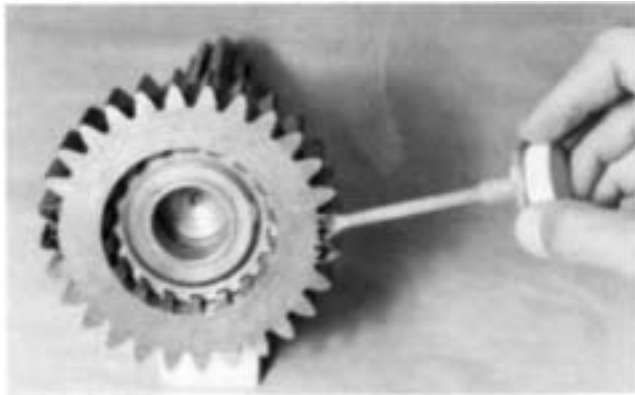

1. Mark any two adjacent teeth on the drive gear and then mark the two teeth directly opposite.

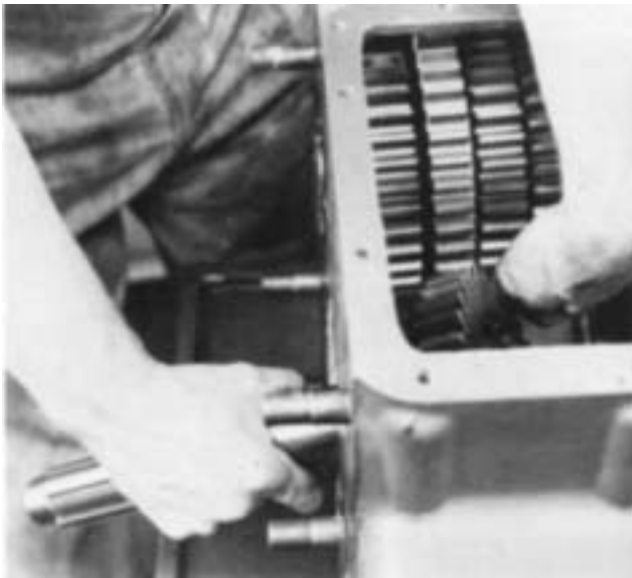

2. Make sure that the snap ring is removed from the drive gear bearing and insert the drive shaft from inside the case through the front bore and move as far forward as possible to expose the snap ring groove in the bearing. It will be necessary to work the drive gear past the countershaft PTO gears.



3. Install the snap ring in the groove in the drive gear bearing. Leave the drive gear in the forward position as installation is not completed until the countershaft bearings are installed.

F. Timing of the Left Countershaft Assembly

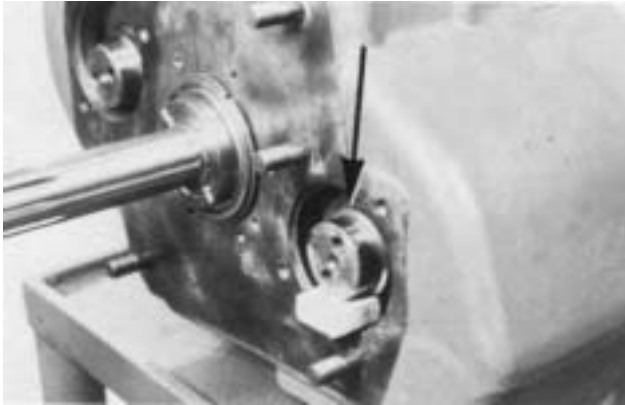

1. Use blocking to center the front of the left countershaft in the case bore.



2. Mesh the marked tooth of the left countershaft drive gear with two of the marked teeth of the main drive gear.

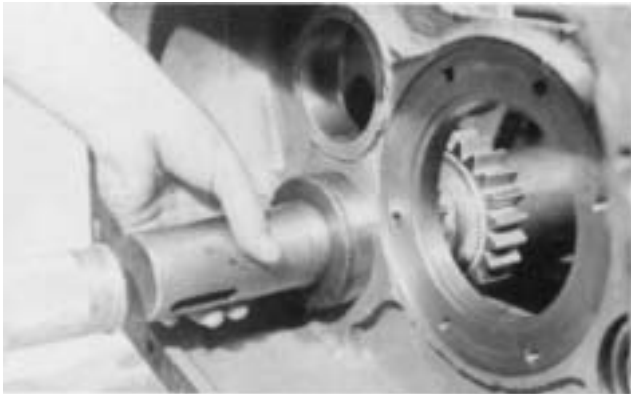

3. With the countershaft as far to the rear as possible, start the rear bearing on the shaft. Center and install the rear bearing on the shaft and in the case bore, seating the bearing against the shoulder of the shaft.



4. Remove the blocking and install the front bearing on the countershaft and in the case bore. Make sure that the timing teeth are still meshed



5. Install the snap ring on the rear of the countershaft.



6. Install the bearing retainer plate on the front of countershaft. Tighten and wire capscrews securely.

Setting Correct Axial Clearances For Mainshaft Gears

Axial Clearance (End Play) Limits Are:
 Reverse speed gear - Minimum of .005"
 Forward speed gears - .005" to .012"

Washers are used to obtain the correct limits; six thicknesses are available as follows:

LIMITS	COLOR CODE
.248-.250	White
.253-.255	Green
.258-.260	Orange
.263-.265	Purple
.268-.278	Yellow
.273-.275	Black

Refer to Illustrated Parts Lists for washer part numbers. (See page 3).

Always use the low limit washer in the LOW GEAR and 2nd SPEED GEAR positions as shown at right. Refer to the service manual covering mainshaft reassembly for method of assembling parts.

Reverse gear clearance must be set as low as possible to the minimum .005". Clearance can be measured before the mainshaft assembly is installed in the case. This is done by securing the reverse gear in position on mainshaft with the reverse gear snap ring and the front snap ring; then, secure auxiliary drive gear assembly in position at rear of mainshaft with the rear snap ring. (See page 110).

**The "LOW", "1st", "2nd" and "3rd" speed gear designations are the nomenclatures for 9- and 13-speed direct models. Gear speeds shown in parentheses are nomenclatures for 10- and 15-speed direct models. On overdrive models, the 3rd (or 4th) speed gear becomes 4th (or 5th) speed gear.

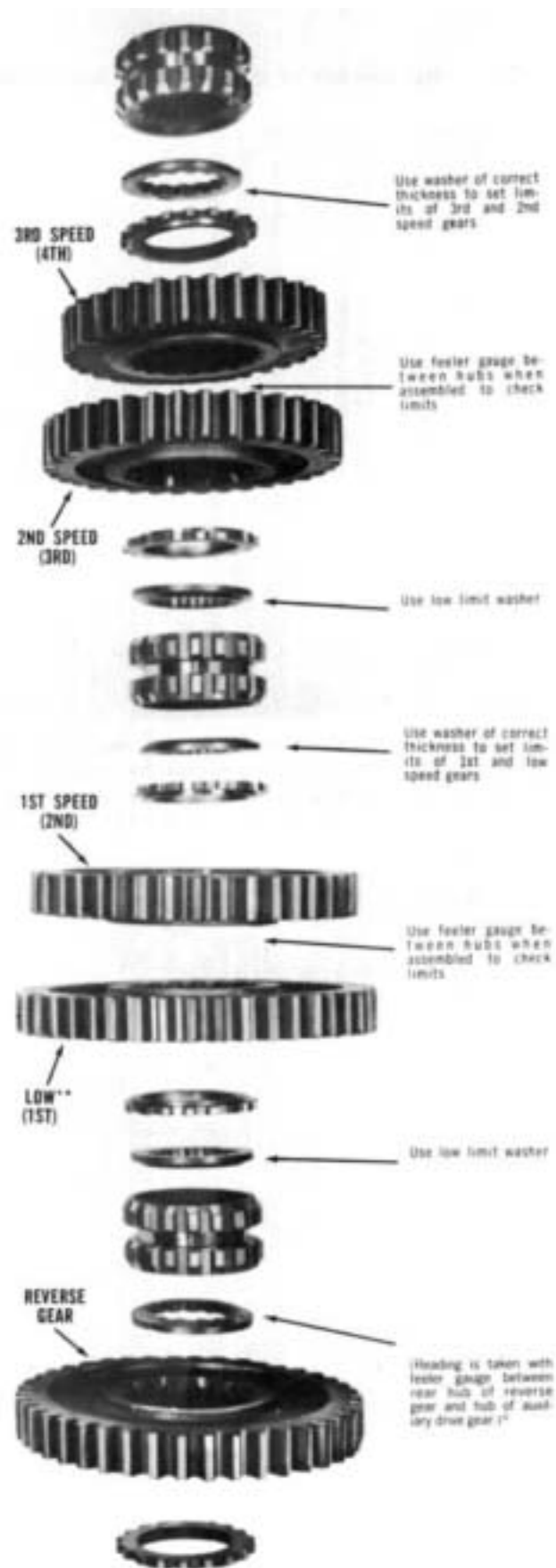

G. Reassembly of the Mainshaft Assembly

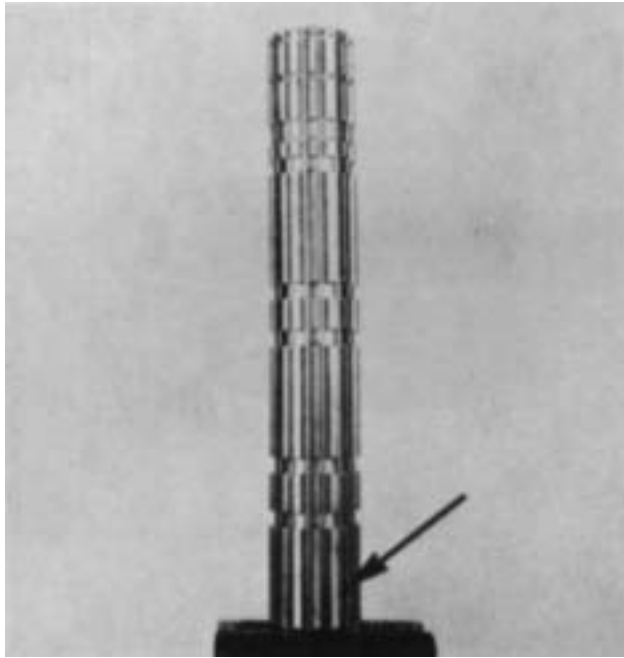

1. If previously removed, install the snap ring in the groove in ID of all mainshaft gears except the reverse gear and mount the mainshaft in a vise with the pilot (front) end down, making sure that the roll pin is in place in the keyway.

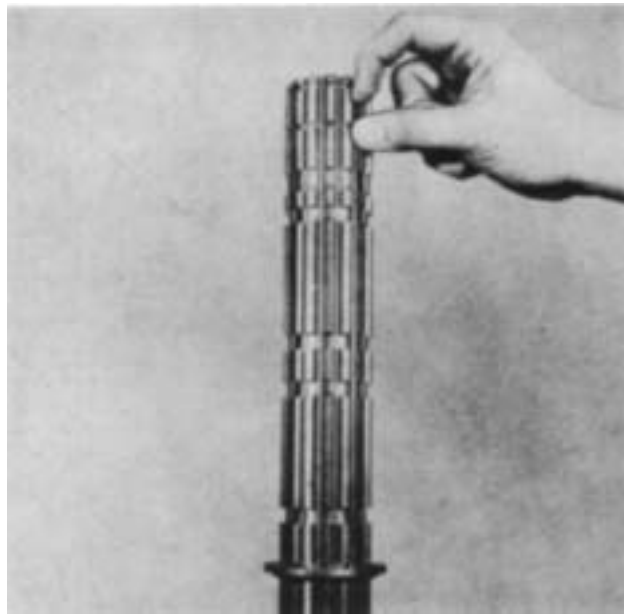

2. Install the 4th speed gear washer, flat side up, and lock in place with the key.

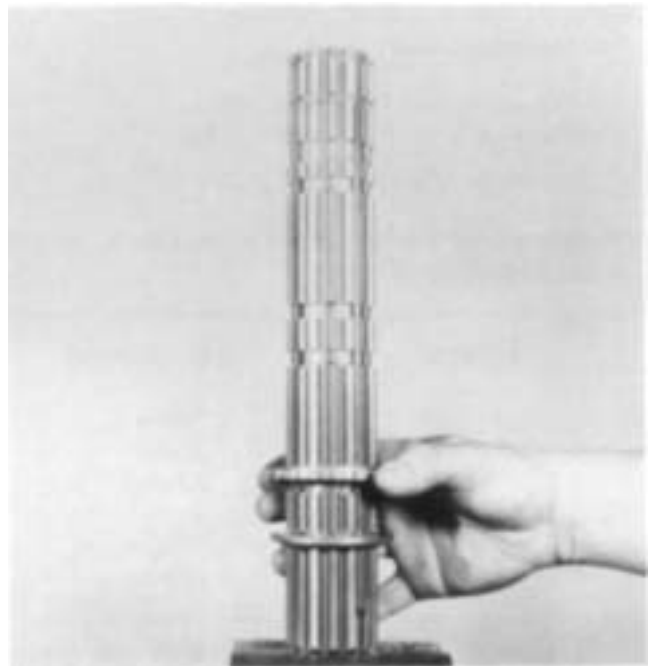

3. Install the spacer on the washer, stepped side up.



4. Install the 4th speed gear on the shaft with the clutching teeth down. Turn the gear until it engages the splines of the spacer.

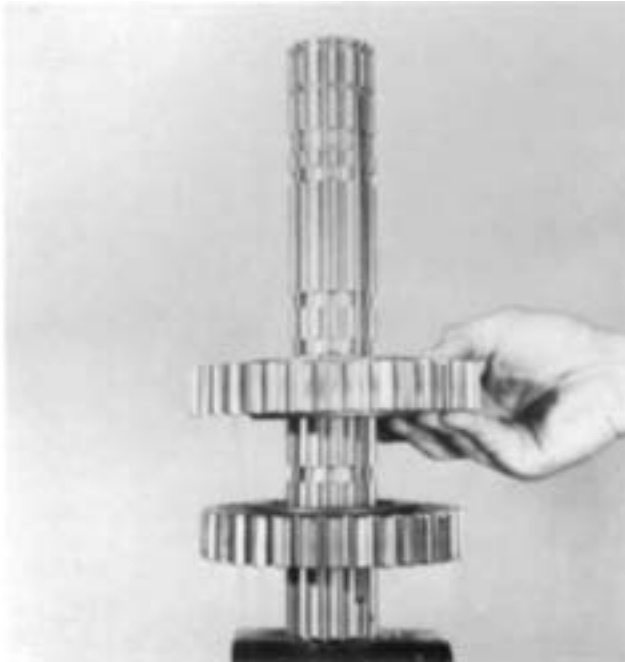

5. Install the 3rd speed gear on the 4th speed gear, clutching teeth up.

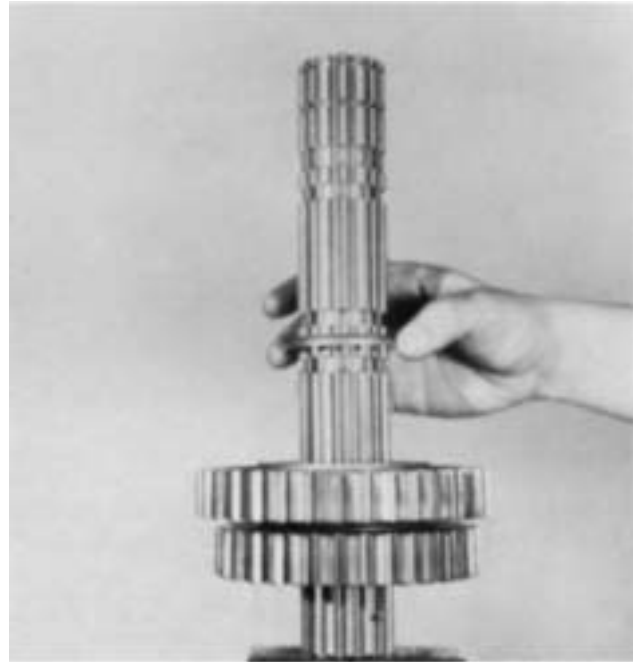

7. Remove the key and install the 3rd speed gear washer on the shaft and in the gear. Turn the washer to align the large slot with the keyway. Lock the washer in place with the key.

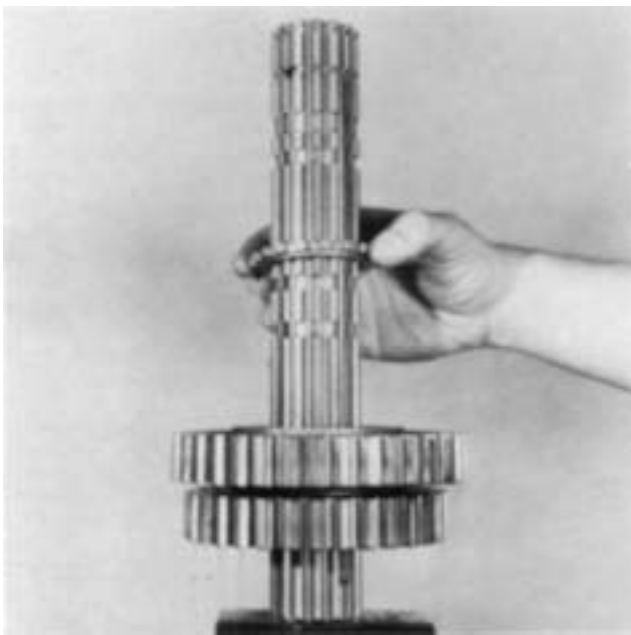

6. Install the spacer on the shaft and in the 3rd speed gear, stepped side down.

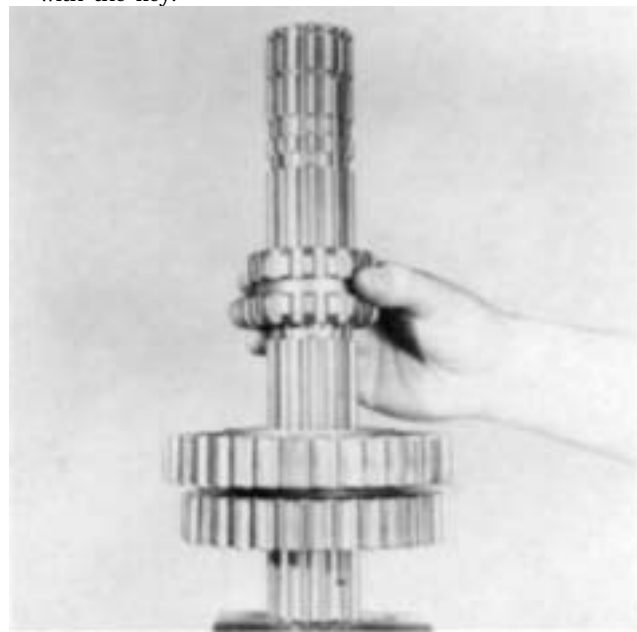

8. Install the 2nd-3rd speed sliding clutch on the shaft, aligning the large groove in the clutch with the keyway. Remove the key.

G. Reassembly of the Mainshaft Assembly - continued

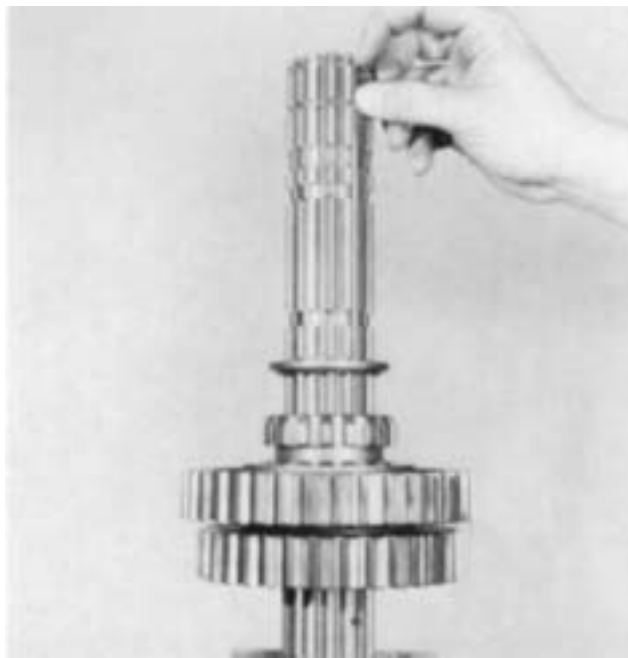

9. Install the 2nd speed gear washer on the shaft, flat side up, turn to align the large slot with the keyway and lock in position with the key.

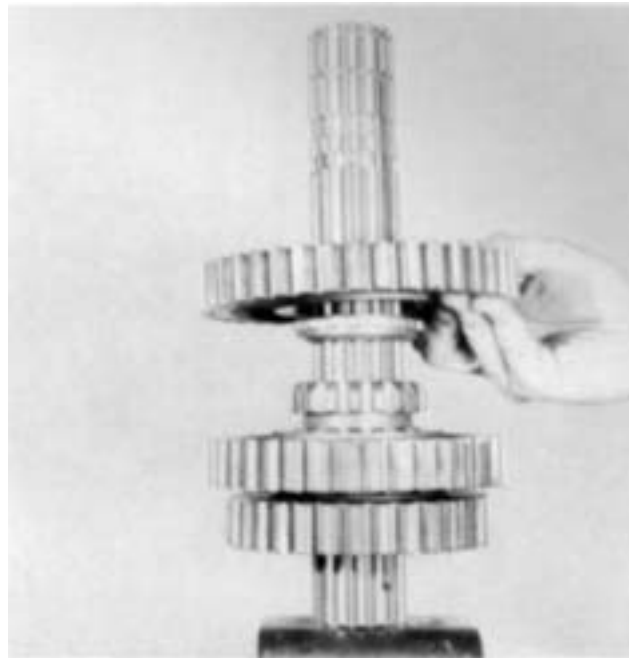

11. Install the 2nd speed gear on the shaft against the stepped spacer, clutching teeth down. Turn the gear until its splines engage with the splines of the spacer.

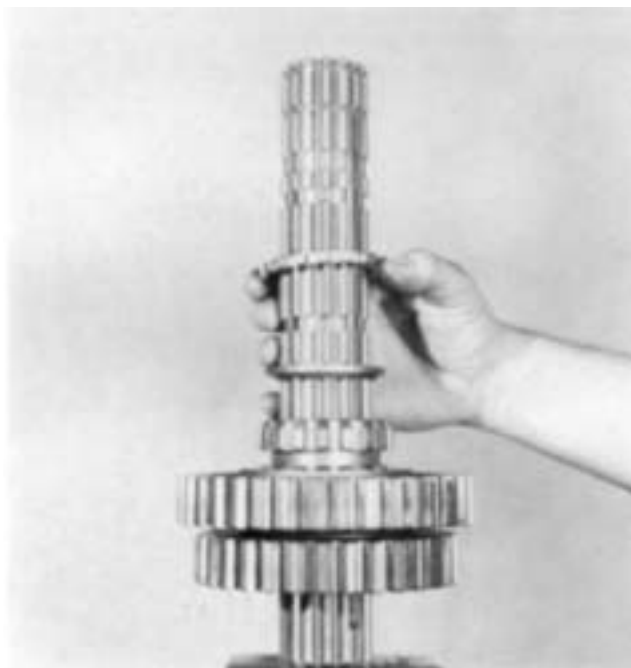

10. Install the stepped spacer on the washer, flat side down.

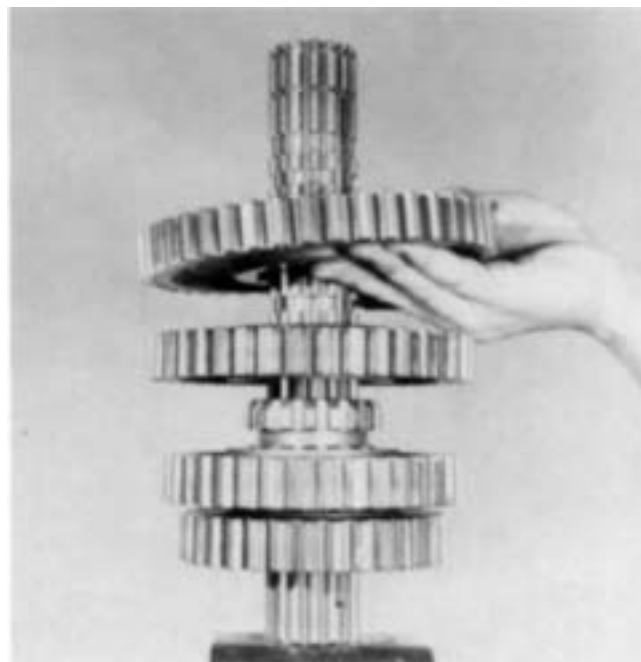

12 Install the 1st speed gear on the shaft against the 2nd speed gear, clutching teeth up.

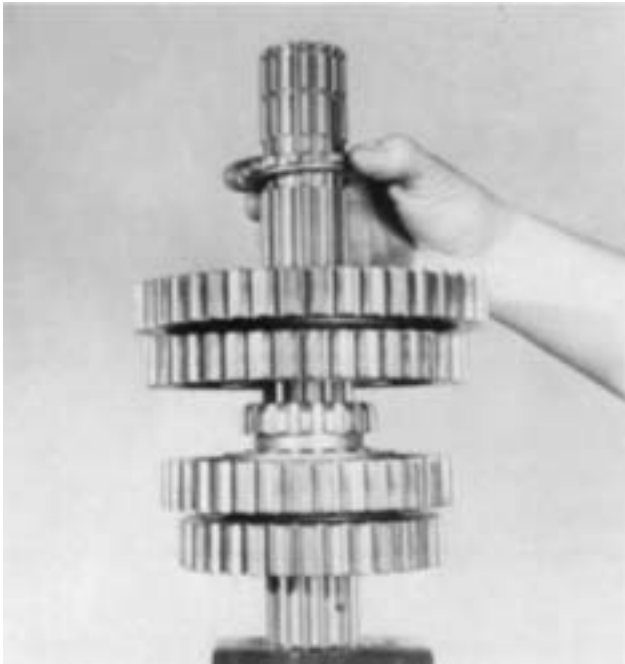

13. Install the 1st speed gear spacer on the shaft and in the gear, flat side up.

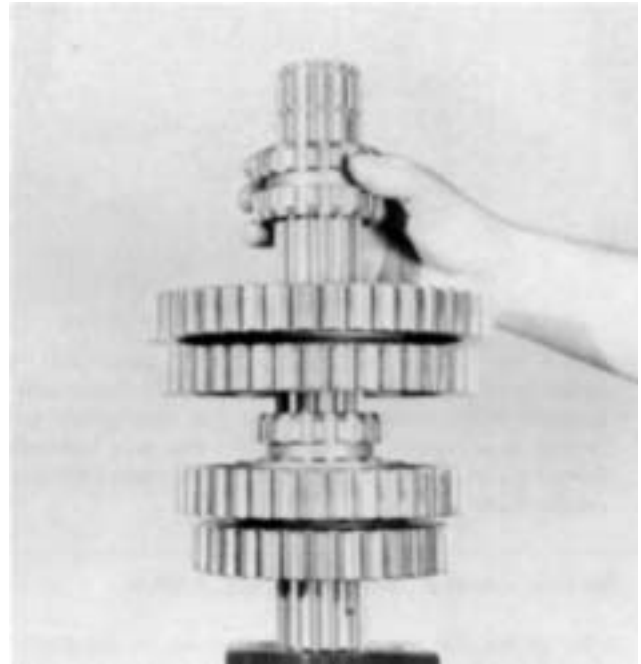

15. Align the large slot with the keyway and install the 1st-reverse speed sliding clutch.

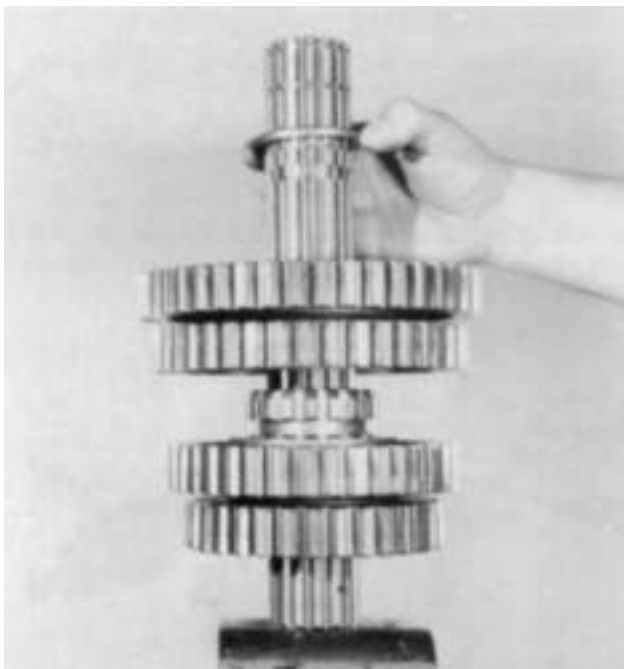

14. Remove the key and install the 1st speed gear washer on the shaft, flat side down. Align the large slot in the washer with the keyway and lock in position with the key.

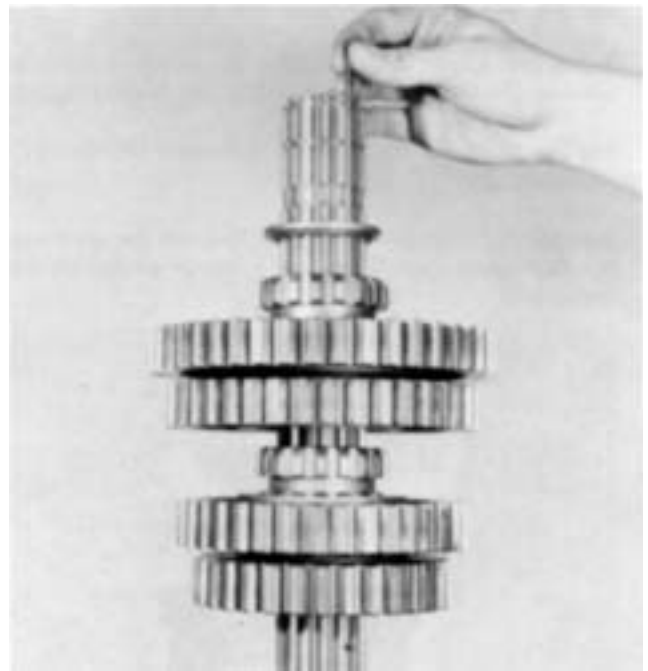

16. Remove the key and install the reverse gear washer on the shaft. Align the large slot in the washer with the keyway and lock in position with the key.

G. Reassembly of the Mainshaft Assembly - continued



17. Install the reverse gear on shaft and against the 1st speed gear, engaging splines of the sliding clutch gear. Remove the assembly from the vise and install the reverse gear spacer on the shaft, flat side forward. Install the snap ring in the groove at the end of the key on the shaft.

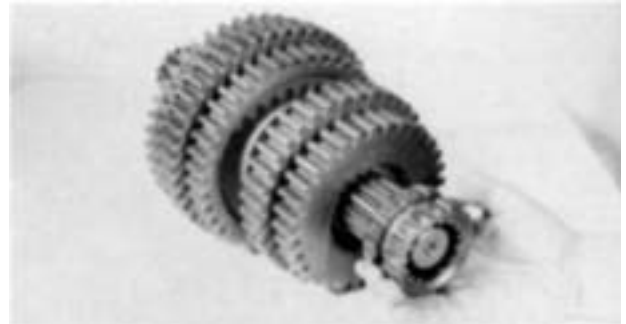

18. Install the sliding clutch gear on the front of the mainshaft.

Setting Reverse Gear End-play Limits

After setting the correct axial clearances for the mainshaft forward speed gears, (see page 105), secure the mainshaft assembly in a vise with the front end down. install the snap ring in the hub of the reverse gear find install the gear on the shaft in its proper position with the clutching teeth facing down.

Install the auxiliary drive gear assembly on the shaft in its proper position and secure the assembly to the shaft with the rear mainshaft snap ring. (Photo A)

Insert two screwdrivers between the auxiliary drive gear and the reverse gear and pry upwards. Insert a feeler gauge between the hubs of the reverse gear and the auxiliary drive gear to check clearance. (Photo B)

Use the chart on page 105 to determine the correct washer to use to bring the clearance as close as possible to the minimum .005".

Remove the auxiliary drive gear. Remove the snap ring from the hub of the reverse gear and allow the gear to rest on the first speed gear. Replace the reverse washer on the shaft with the correct thickness washer and proceed with the reassembly.



H. Installation of the Mainshaft Assembly and Right Countershaft



1. Block the right countershaft assembly against the side of the case, move the reverse gear on the mainshaft forward and against the mainshaft 1st speed gear and lower the mainshaft assembly, rear end first, into the case. Slide the mainshaft forward, installing the front of the shaft in the bushing in the input shaft.

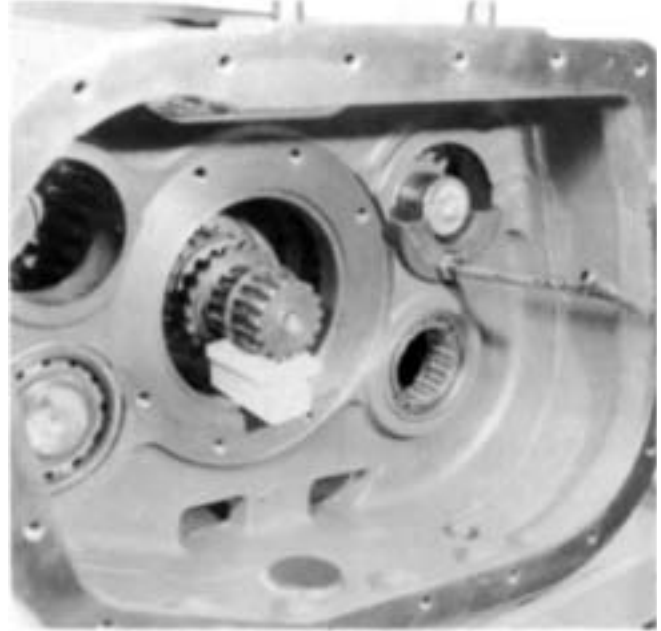

3. Use wood blocks or equivalent to center the rear of the mainshaft and the countershaft and partially install the front countershaft bearing. Complete installation of the countershaft bearings in the same manner as used for the left countershaft bearings.

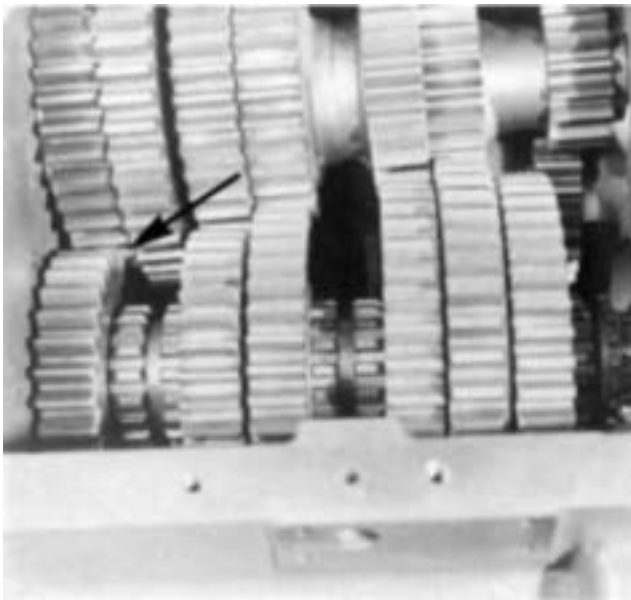

2. Remove the blocking from the right countershaft and move the countershaft into position, making sure that the marked tooth on the countershaft drive gear meshes between the marked teeth on the drive gear. Check to make sure that the left countershaft has remained in time.

Reassembly — Front Section

1. Reassembly and installation of the Left Reverse Idler Gear

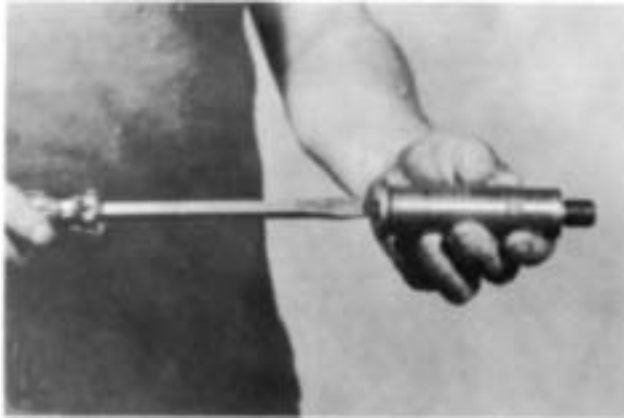

1. Install plug in reverse idler shaft.

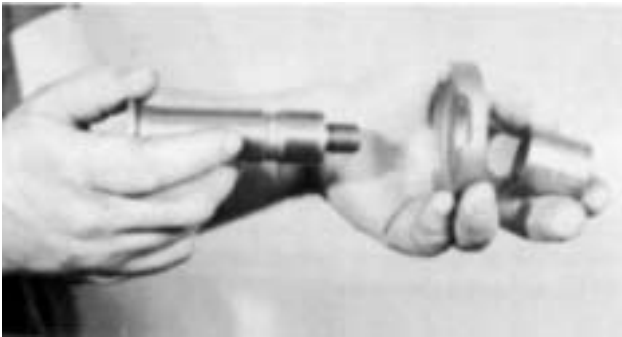

2. Install the rear washer and bearing inner race on the shaft. If previously removed, press the needle bearing in the bore of the gear.

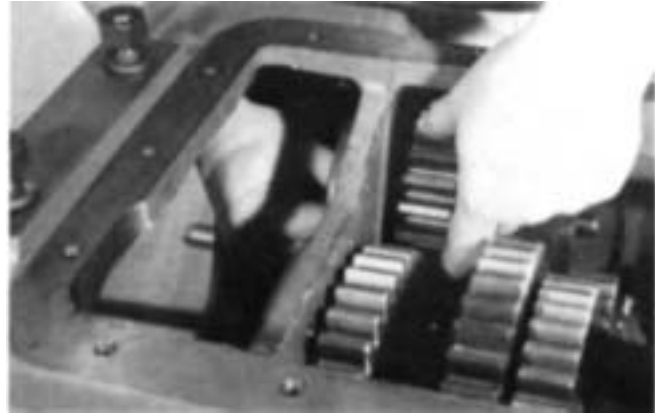

3. Hold the gear and thrust washer in place in the case with the thrust washer between the gear and housing boss and the idler gear meshed with the teeth of the countershaft reverse gear. Insert the idler shaft through the bore in the rear case wall, the gear and washer and the housing boss. Make sure that the long hub of the gear faces towards the front of the case.

NOTE: Do not force the shaft into the gear, as this will result in damage to the bearing. Check the needle bearing to make sure that all the rollers are in place.



4. Secure the shaft with the washer and elastic stop nut.

J. Final Installation of the Mainshaft Assembly



1. Move the reverse gear as far as possible to the rear, against the wall of the case and mesh teeth with those of the reverse idler gears. Slide the reverse gear spacer forward and into the reverse gear.

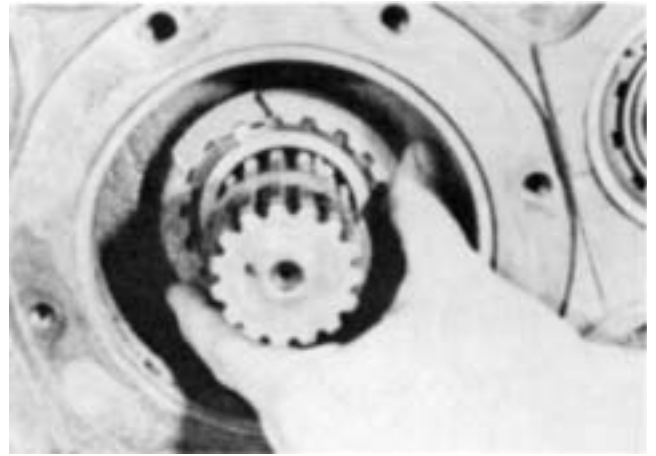

3. Move the reverse gear forward on the shaft and into correct position.

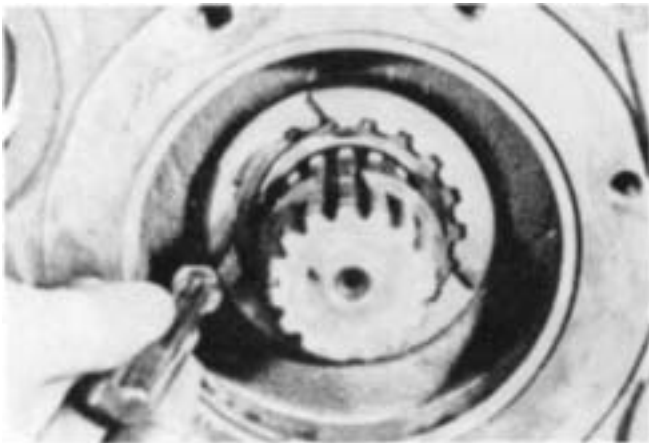

2. Install the snap ring in the hub of the reverse gear.

K. Reassembly and installation of the Auxiliary Drive Gear Assembly

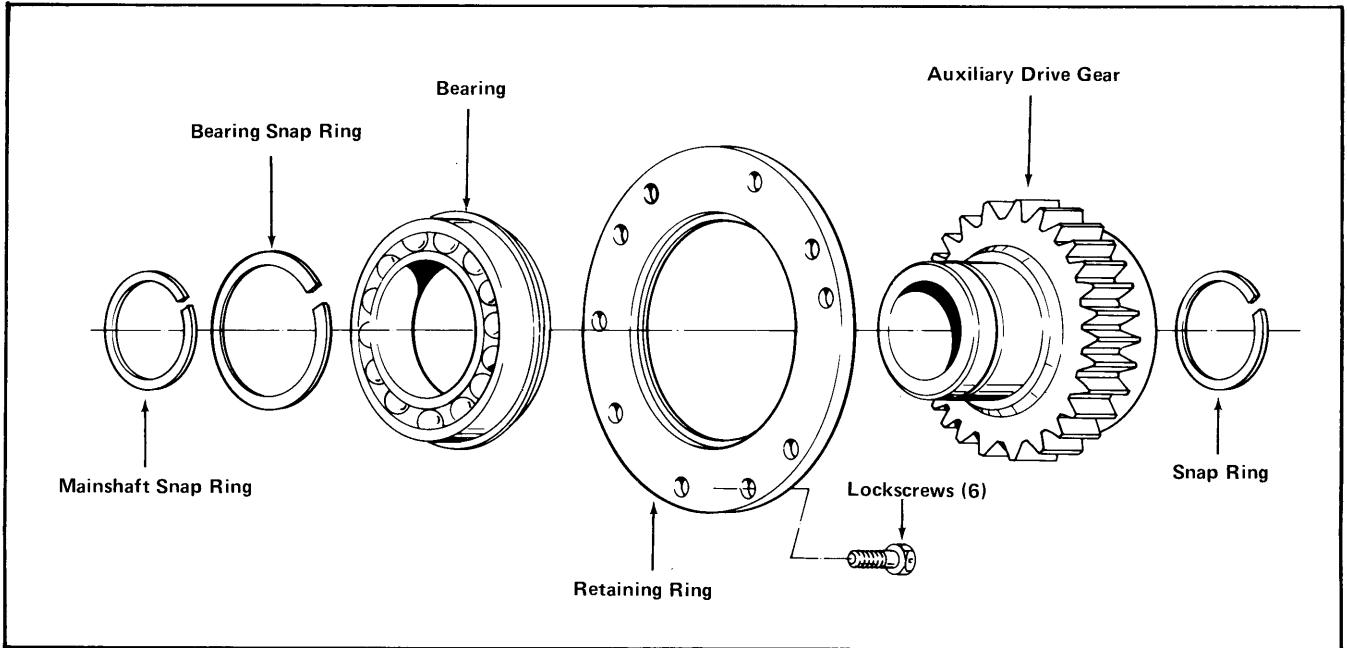

1. Install the retainer ring on the gear with the groove in the ring facing away from the gear.



2. Install the bearing on the gear with the snap ring facing the groove in the retainer. Tap lightly on the inner race of the bearing with a soft bar and mall.



3. Install the snap ring in the drive gear groove to secure the bearing to the gear.

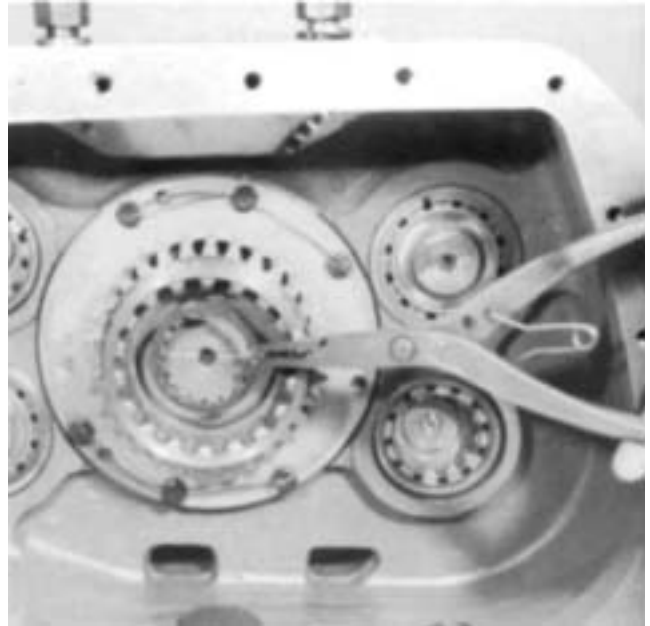

5. Install the snap ring on the end of the mainshaft.

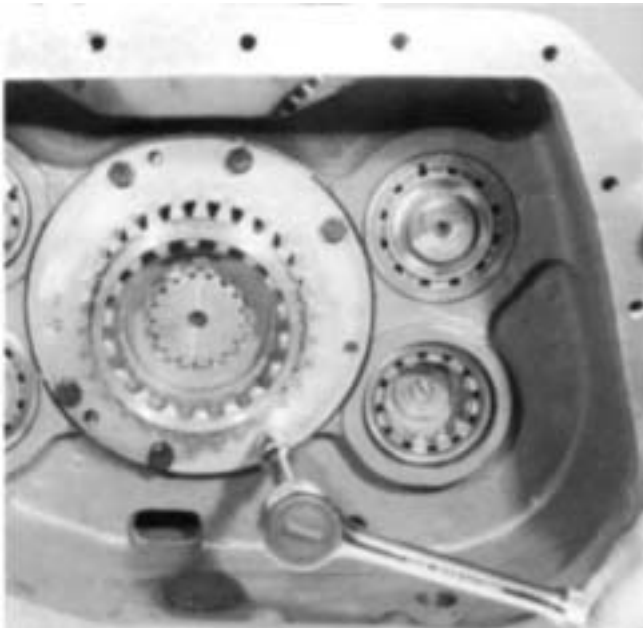

4. Install the auxiliary drive gear on the end of the mainshaft and use a driver and mallet to seat the bearing in the bore. Align the six lock screw holes in the retainer with the lock screw bores in the case boss. Install the six lock screws; tighten and wire securely in groups of three.

V. Companion Flange, Auxiliary Housing and Clutch Housing

A. Installation of the Clutch Housing

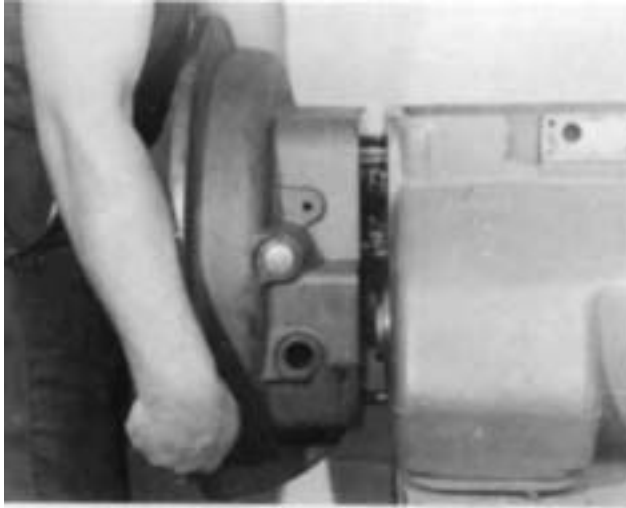

1. Install the clutch housing on the six studs on the front of the case. Move the housing evenly against the case piloting the housing on the drive gear bearing cover.

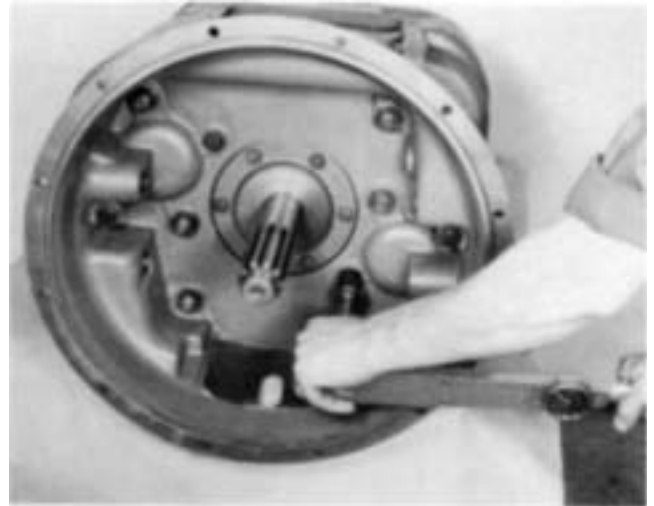

2. Install the lockwashers and nuts on the studs and install the four bolts in the housing. Secure the nuts with 180-190 ft./lbs. of torque, and secure the bolts with 90-100 ft.fibs. of torque.

B. Installation of the Auxiliary Housing

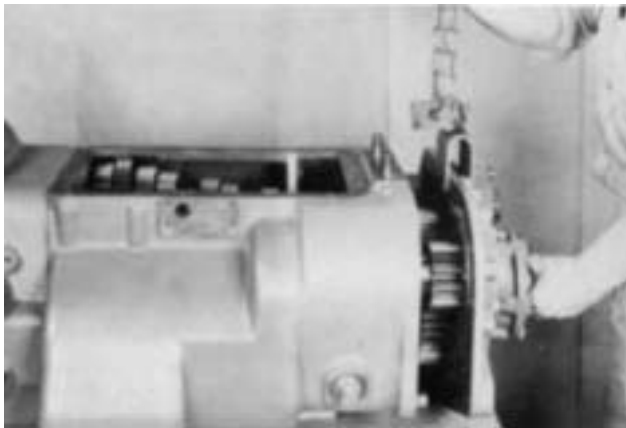

1. Place a chain hoist on the auxiliary section to properly balance and hold its weight. Move the auxiliary section evenly onto the rear of the front case. The two countershaft drive gears will mesh with the auxiliary drive gear and the front of both countershaft will seat in the two bearings installed in the front section. Move assembly evenly, rotating drive gears if necessary to properly mesh the gears.

IMPORTANT: Make sure that the bearing inner race has been installed on the front of each auxiliary countershaft.

2. (RT-12515) If the auxiliary housing is to be installed on the front case horizontally, it is advisable to time the auxiliary countershaft to the auxiliary drive gear. The extreme length and weight of the auxiliary countershaft can cause them to drop a tooth out of time on the auxiliary drive gear.

C. Installation of the Companion Flange or Yoke

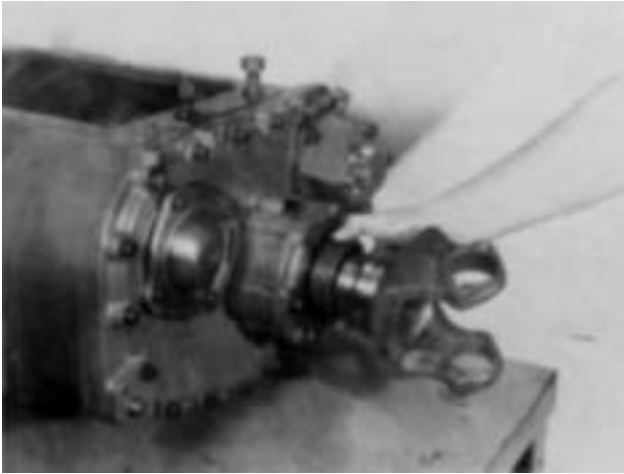

1. Lock the mainshaft in two speeds and install the speedometer drive gear on the replacement spacer on the flange or yoke. Install the flange or yoke on the splines of the output shaft.

NOTE: On RT-12510 and RT-12515 transmissions, the speedometer drive gear or replacement spacer should be installed prior to installation of the rear bearing housing.

2. Secure the flange or yoke with the elastic stop nut, and washer tightening with a torque wrench to 450-500 ft./lbs. of torque.

VI. Shifting Controls

A. Reassembly of the Shift Bar Housing Assembly

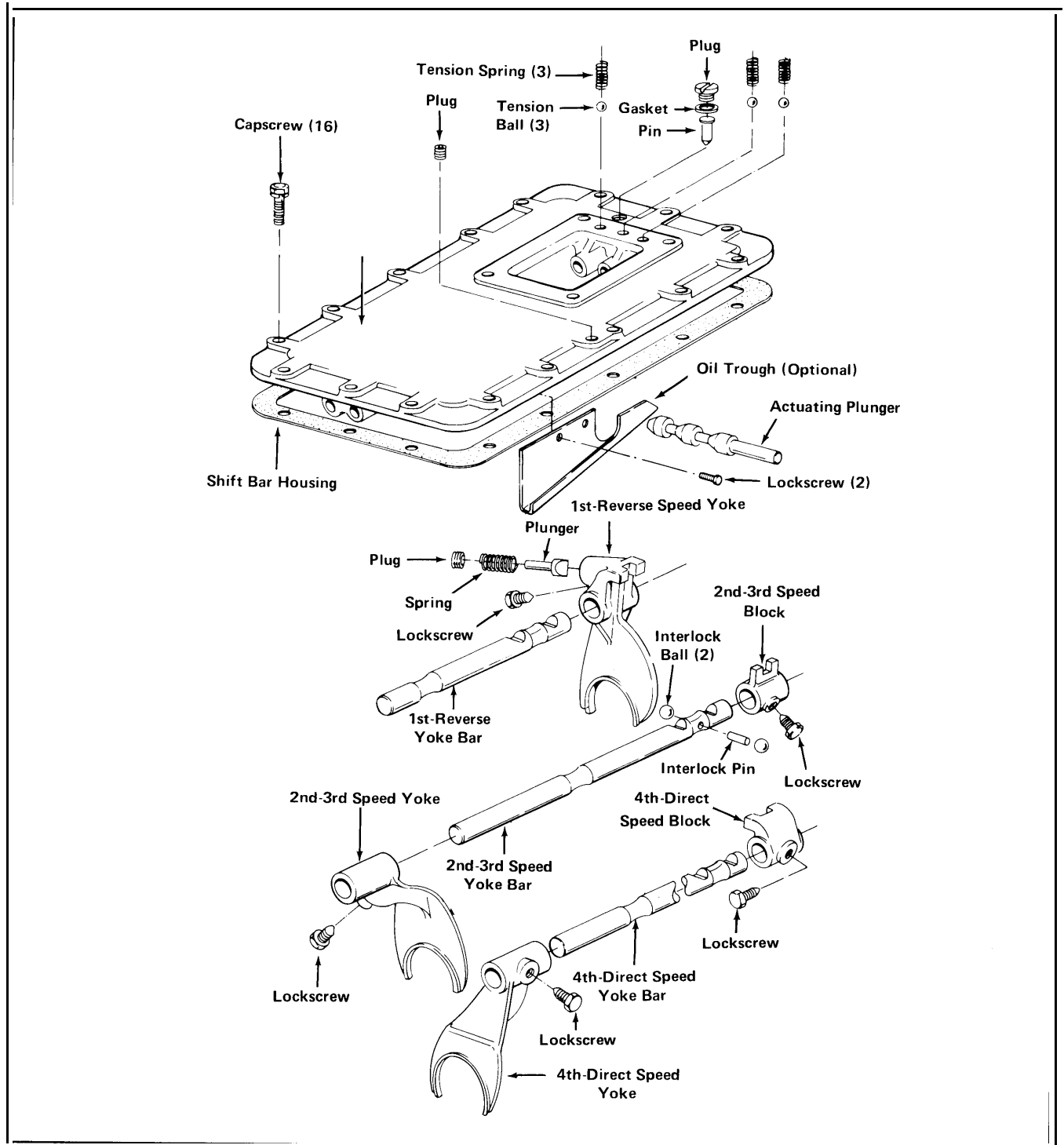

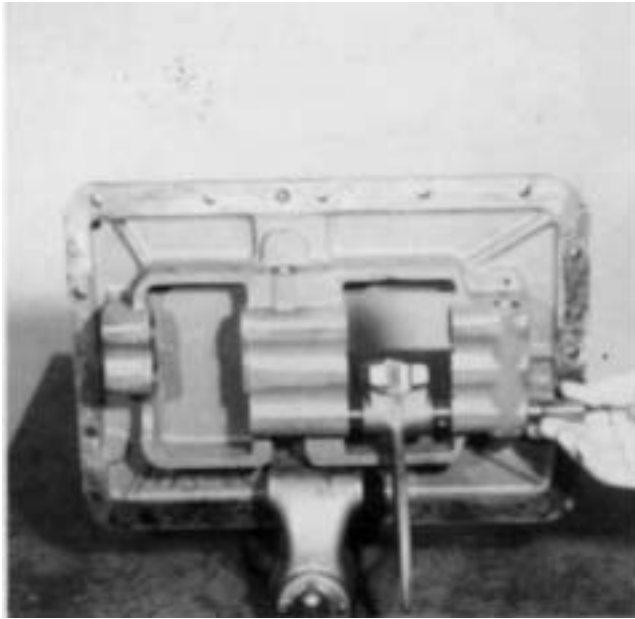

1. Mount the shift bar housing in a vise and hold the 1st-reverse speed yoke in the indicated position. Insert the 1st-reverse shift bar through the housing boss and the yoke with the end of the bar with the three notched entering the boss last. Align the lockscrew bores on bar and the yoke. Insert the yoke lockscrew; tighten to 35-45 ft./lbs. of torque and wire securely.

CAUTION: Installing the yoke lock screws with more than 45 ft./lbs. of torque can result in distortion of the shift bars.

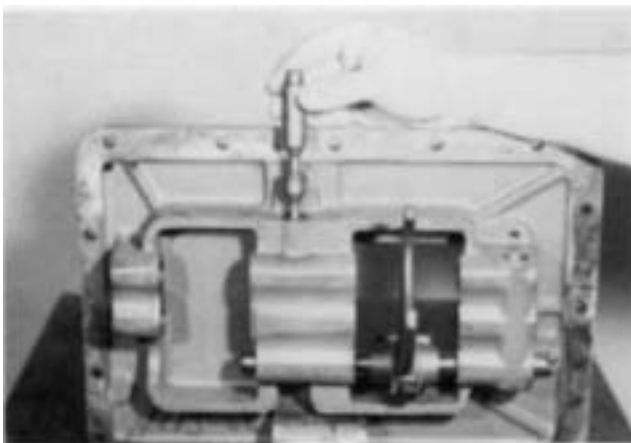

2. Install the actuating plunger in the case boss,

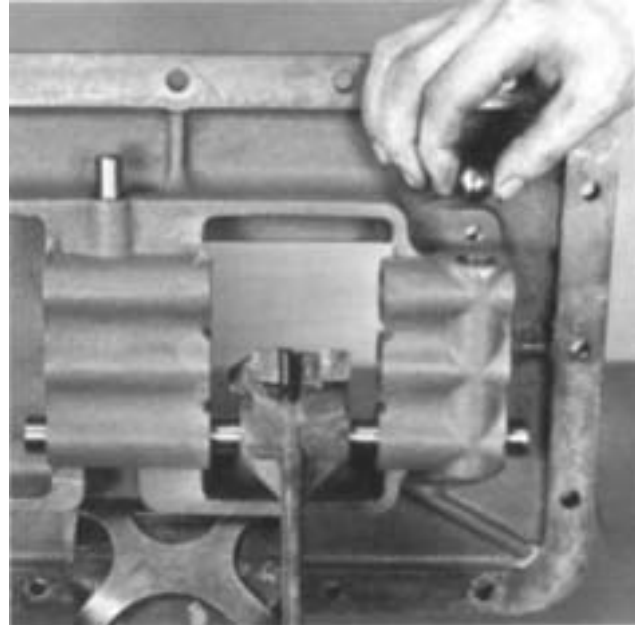

3. Insert an interlock ball in the case boss.

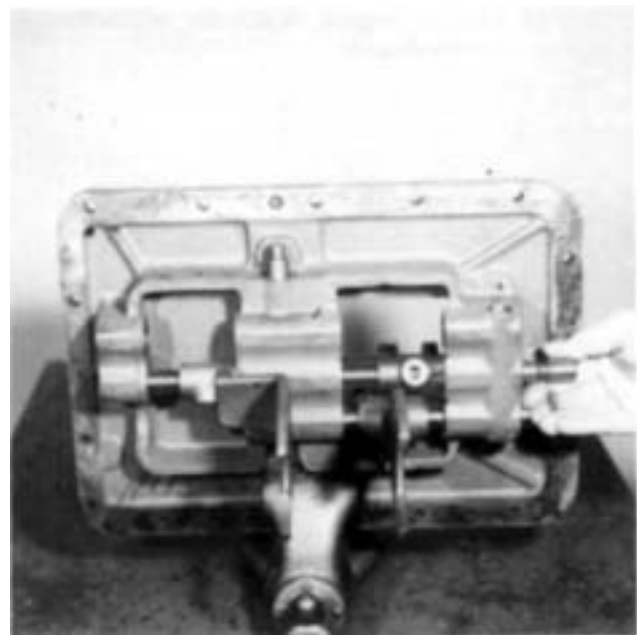

4. Install the 2nd-3rd speed shift yoke and block on the shift bar as it is inserted into the housing boss. Install the pin in the neutral notch of the bar as it is inserted into the boss. Install the yoke and block lockscrews; tighten and wire securely.

Reassembly — Shift Bar Housing

A. Reassembly of the Shift Bar Housing Assembly - continued

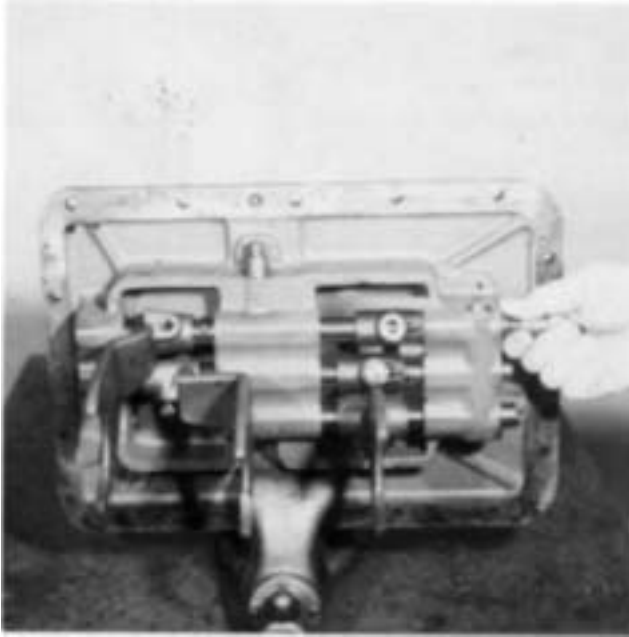

5. Insert an interlock ball in the case boss and install the 4th-5th speed shift yoke and block on the bar as it is inserted into the housing. Install the two lockscrews; tighten and wire securely.

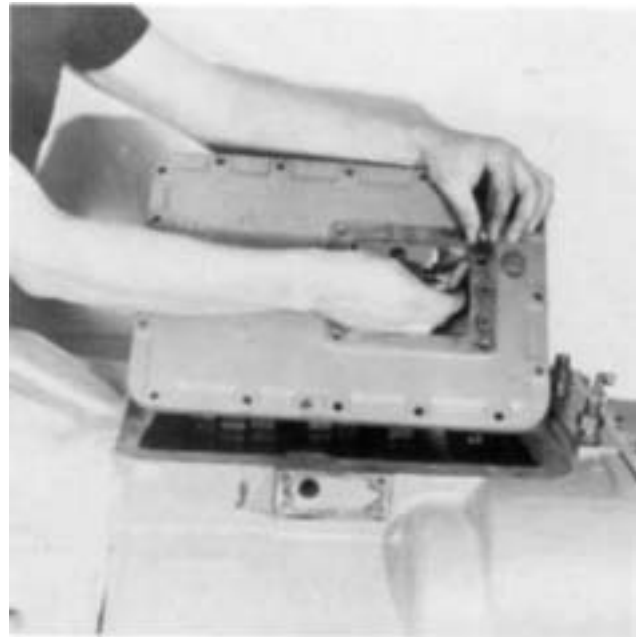

7. Remove the housing from the vise and install the three tension balls in the bores. Install the tension springs over the balls.

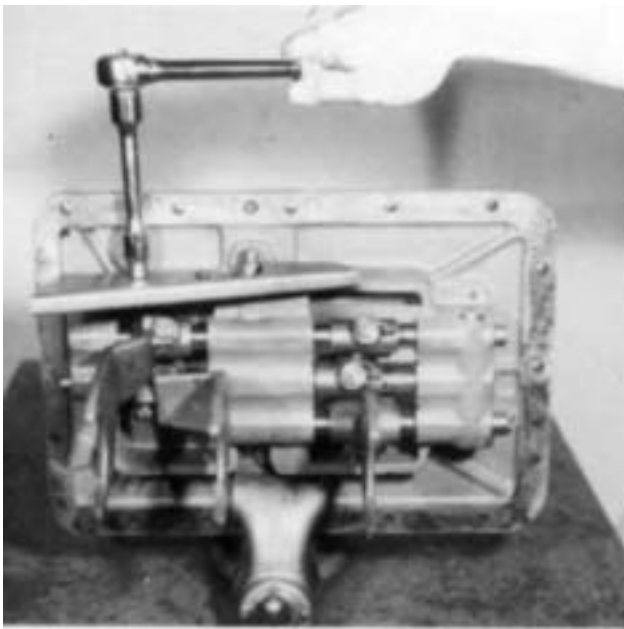

6. Install the oil trough on the housing. (Oil trough is optional). Tighten lock screws and wire securely.

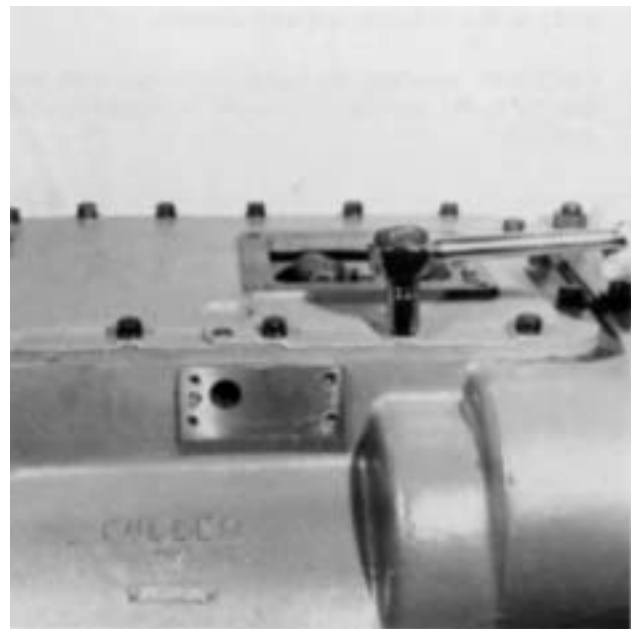

8. Make sure that the shift bars and the sliding clutches are all in the neutral position and install the shift bar housing on the front case. Secure with the 16 capscrews.

B. Reassembly of the Gear Shift Lever Housing Assembly



1. Install the O-ring in the top of the housing.

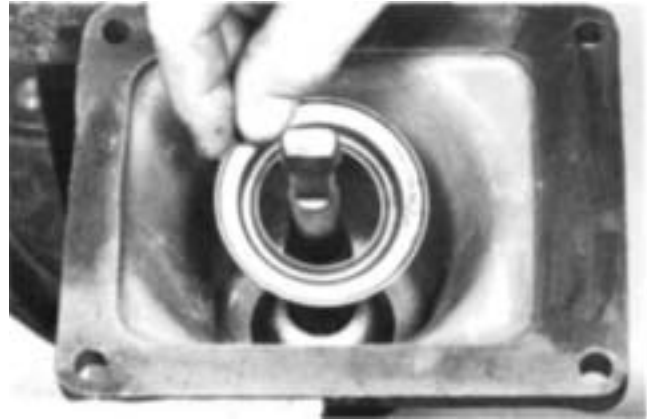

4. Install the tension spring washer in the housing.



2. Install the pivot pin in the housing, threaded end out, and secure with the nut and lockwashers.



3. Install the housing in a soft-jawed vise with the bottom facing up and insert the shift lever in the housing, fitting the slot in the pivot ball of the lever with the pivot pin.

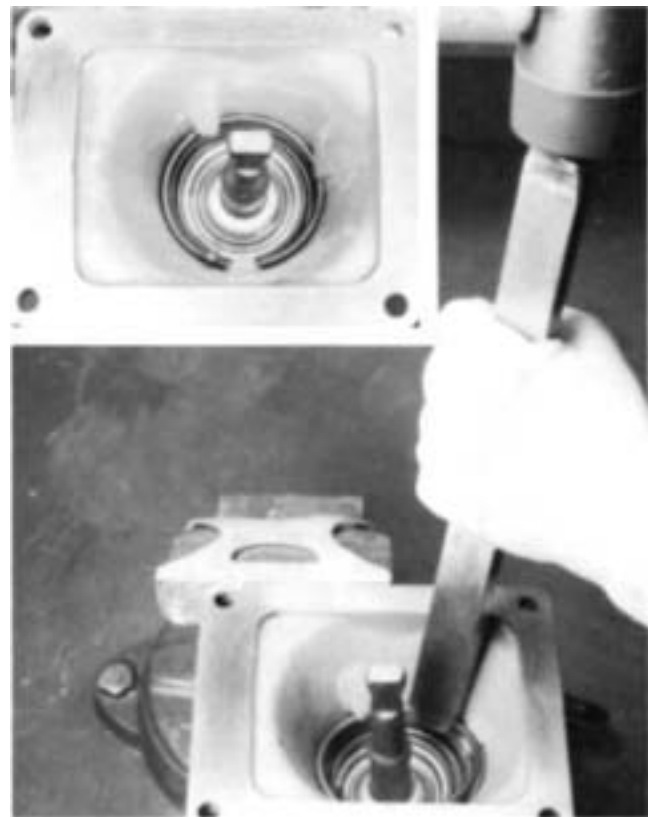

5. Install the tension spring in the housing, seating the spring under the lugs cast in the housing. Install the gear shift lever housing on the shift bar housing with the reinforced end over the three tension springs.

Reassembly-Air System

C. Reassembly of the Air System

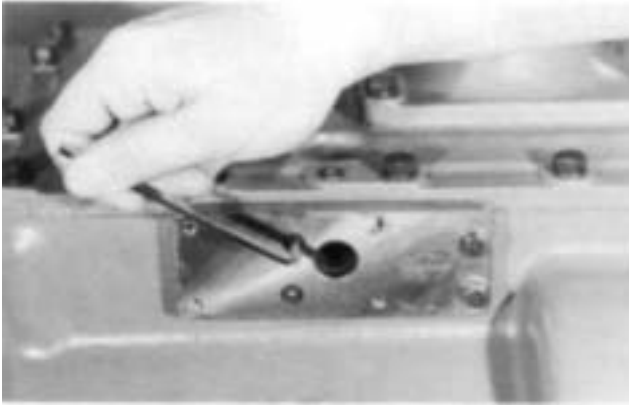

1. Install the adapter plat on the front case. Use the alignment sleeve to make sure that the bore in the adapter plate lines up properly with the bore in the front case.



4. Install the air valve on the adapter plate, tightening the four capscrews evenly.

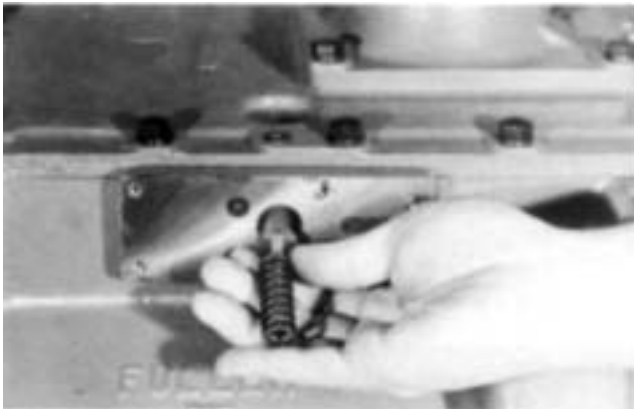

2. Install the actuating pin and spring in the bore.

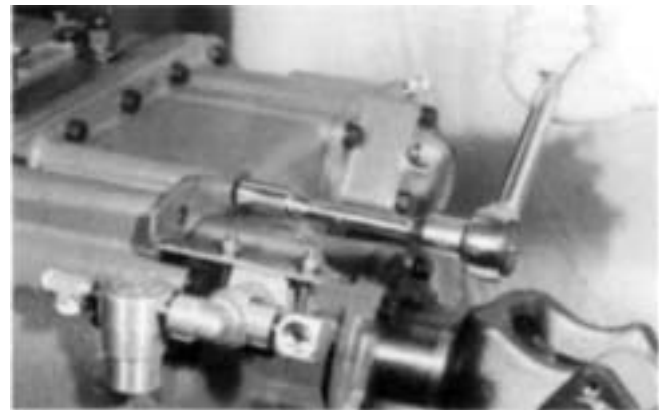

5. If previously removed, install the brass fittings in the air valve and range shift cylinder. Secure the filter/regulator assembly and the air valve.



3. Check to make sure that the piston in the air valve is either all the way forward or all the way to the rear and install the alignment sleeve in the bore.



6. Connect the 1/4" ID supply air line between the filter/regulator assembly and the air valve.

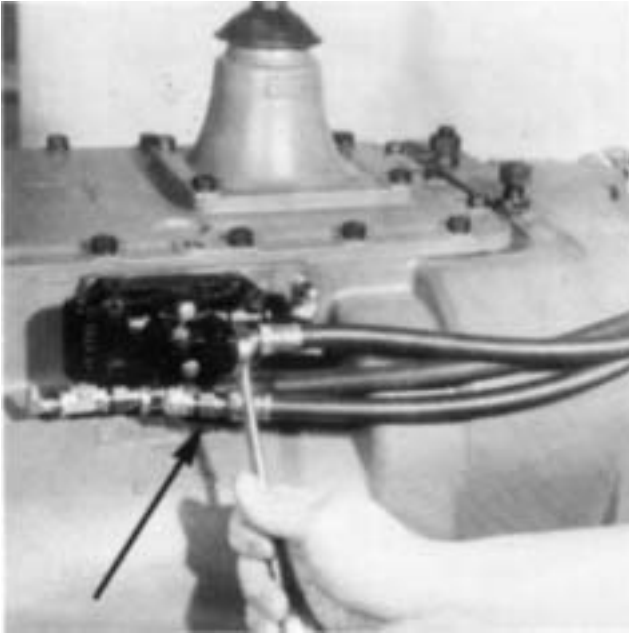

7. Connect the two 1/4" ID air lines between the air valve and the range shift cylinder. The front fitting on the shift cylinder is connected to the bottom fitting on the air valve side cap (arrow), and the rear fitting on the shift cylinder is connected to the rear bore on the air valve side cap.



8. Install the range control valve on the gear shift lever so that the control button is approximately 6" below the centerline of the ball. Secure the valve by tightening the screw on the clamp.

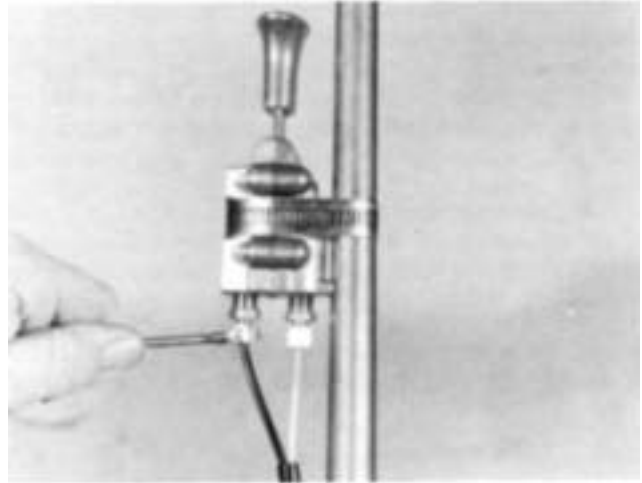

9. Connect the black and white 1/8" OD air lines to the control valve as indicated.



10. Connect the 1/8" OD air lines at the air valve as indicated.

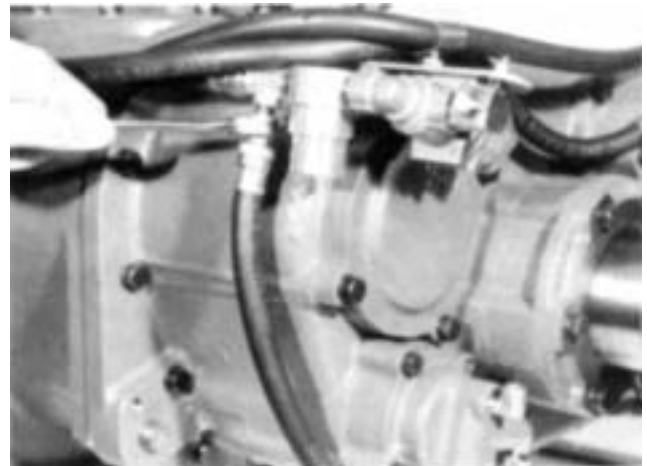

11. (RT-12515 Models) Connect the 1/4" ID air line between the "T" fitting forward of the filter/regulator assembly and the deep reduction shift cylinder.

Tool Reference

A few special tools are required in the disassembly and re-assembly of Fuller transmissions. Although in many instances basic mechanic's tools may be substituted with adequate results, it is highly recommended that the special tools be made or purchased and used to ensure proper results and avoid possible damage to the parts being installed or removed.

Fuller does not make or sell the tools listed, but tool prints and catalogs of known manufacturers of ready made tools are available upon request. Please mention tool print number and model of transmission when ordering. Write:

Service Department / Eaton Corporation / Transmission Division / 222 Mosel Avenue/ Kalamazoo, Michigan 49007



OIL SEAL DRIVER Print Number T-18088-37
Print Number T-18088-36 (RT-1110)

Used to install the oil seal in the rear bearing housing.



AUXILIARY PLATE HANGER BRACKET
Print Number T-22823

Used to support the auxiliary plate during removal and installation on the front case.

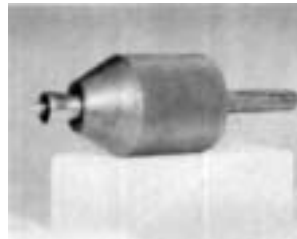

SNAP RING INSTALLER Print Number T-16552-1-N

Used to install the snap ring in the output shaft quill. (RT-I2515 Series)

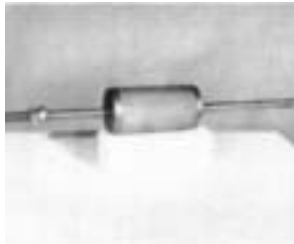

IMPACT PULLER Make from 18" steel rod threaded 1/2-13 on one end, attach end block and sliding block. Used to remove reverse idler shafts.

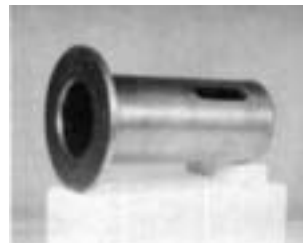

BEARING DRIVERS Print Number T-18042 (Dimensions for all drivers necessary on this print.)

Used to install bearings on shafts and in bores.



DRIVE GEAR BEARING NUT REMOVER
Print Number T-22553B

Print Number T-22553C (For push-type clutches)

Used to remove or install the drive gear bearing nut on the shaft.



OUTPUT SHAFT HANGER BRACKET Make from yoke stop nut and flat steel stock

Used to support the auxiliary section when installed or removed from the front case in the vertical position.

Copyright Eaton Corporation, 2012. Eaton hereby grant their customers, vendors, or distributors permission to freely copy, reproduce and/or distribute this document in printed format. It may be copied only in its entirety without any changes or modifications. THIS INFORMATION IS NOT INTENDED FOR SALE OR RESALE, AND THIS NOTICE MUST REMAIN ON ALL COPIES.

Note: Features and specifications listed in this document are subject to change without notice and represent the maximum capabilities of the software and products with all options installed. Although every attempt has been made to ensure the accuracy of information contained within, Eaton makes no representation about the completeness, correctness or accuracy and assumes no responsibility for any errors or omissions. Features and functionality may vary depending on selected options.

For spec'ing or service assistance, call 1-800-826-HELP (4357) or visit www.eaton.com/roadranger. In Mexico, call 001-800-826-4357.

Roadranger: Eaton and trusted partners providing the best products and services in the industry, ensuring more time on the road.

Eaton Corporation

Vehicle Group
P.O. Box 4013
Kalamazoo, MI 49003 USA
800-826-HELP (4357)
www.eaton.com/roadranger

Printed in USA

For parts or service call us
Pro Gear & Transmission, Inc.



1 (877) 776-4600

(407) 872-1901

parts@eprogear.com

906 W. Gore St.

Orlando, FL 32805

