

Fuller Heavy Duty Transmissions TRSM0440

August 2009

RTX-11709A
RTX-11709B
RTX-11709H
RTX-11710B
RTX-11710C
RTX-12709A
RTX-12709B
RTX-12709H
RTX-12710B
RTX-12710C
RTX-13709H
RTX-13710B
RTX-13710C
RTX-14709A
RTX-14709B
RTX-14709H
RTX-14710B
RTX-14710C

RTX-15710B
RTX-15710C
RTX-15715
RTX-16709B
RTX-16709H
RTX-16710B
RTX-16710C
RTXF-11709H
RTXF-11710B
RTXF-11710C
RTXF-12709H
RTXF-12710B
RTXF-12710C
RTXF-13709H
RTXF-13710B
RTXF-13710C
RTXF-14709H
RTXF-14710B

RTXF-14710C
RTXF-15710B
RTXF-15710C



Powering Business Worldwide

BACKED BY

Roadranger

SUPPORT

For parts or service call us
Pro Gear & Transmission, Inc.



1 (877) 776-4600

(407) 872-1901

parts@eprogear.com

906 W. Gore St.

Orlando, FL 32805



Warnings and Precautions

Warnings and Precautions



Before starting a vehicle always be seated in the driver's seat, place the transmission in neutral, set the parking brakes and disengage the clutch.

Before working on a vehicle place the transmission in neutral, set the parking brakes and block the wheels.

Before towing the vehicle place the transmission in neutral, and lift the rear wheels off the ground, remove the axle shafts, or disconnect the driveline to avoid damage to the transmission during towing.

The description and specifications contained in this service publication are current at the time of printing.

Eaton Corporation reserves the right to discontinue or modify its models and/or procedures and to change specifications at any time without notice.

Any reference to brand name in this publication is made as an example of the types of tools and materials recommended for use and should not be considered an endorsement. Equivalents may be used.



This symbol is used throughout this manual to call attention to procedures where carelessness or failure to follow specific instructions may result in personal injury and/or component damage.

Departure from the instructions, choice of tools, materials and recommended parts mentioned in this publication may jeopardize the personal safety of the service technician or vehicle operator.

Warning: Failure to follow indicated procedures creates a high risk of personal injury to the service technician.

Caution: Failure to follow indicated procedures may cause component damage or malfunction.

Note: Additional service information not covered in the service procedures.

Tip: Helpful removal and installation procedures to aid in the service of this unit.

Always use genuine Eaton replacement parts.

General Information

Purpose and Scope of Manual	4
Disassemble Precautions	4
Serial Tag and Model Nomenclature	8
Model Options	9
Gear Ratios - XX709, 1X710	11
Torque Ratings	12
Lubrication	14
Tool Information	16
Preventative Maintenance	20
Power Flow	25

Timing

Timing Procedures	27
Front Section	27
Auxiliary Section	28

In-Vehicle Service Procedure

Air System

How to Remove Compression Type Fittings	29
How to Install Compression Type Fittings	30
How to Remove Push-To-Connect Type Fittings	31
How to Install Push-To-Connect Type Fittings	32
How to Remove Rubber 1/4" Air Hoses	33
How to Install Rubber 1/4" Air Hoses	34
How to Install the Air Filter/Regulator	35
How to Remove the Air Filter/Regulator	36
How to Remove a Roadranger Valve	37
How to Install a Roadranger Valve	38
How to Remove a Slave Valve	39
How to Install a Slave Valve	40

Shift Bar Housing

How to Remove the Gear Shift Lever/Remote Shift Control	41
How to Install the Gear Shift Lever/Remote Shift Control	42
How to Adjust the Remote Shift Control (LRC Type)	43
Neutral Switch Operation and Testing	45
How to Remove the Neutral Switch	46
How to Install the Neutral Switch	47
Reverse Switch Operation and Testing	48
How to Remove the Reverse Switch	49
How to Install the Reverse Switch	50

Output Yoke/Companion Flange

How to Remove the Output Yoke/Companion Flange and Nut	51
How to Install the Output Yoke/Companion Flange and Nut	54
How to Remove the Output Yoke/Flange and Retaining Capscrews	55
How to Install the Output Yoke/Flange and Retaining Capscrews	56

Auxiliary Section

How to Remove the Auxiliary Section with Tapered Bearings	57
How to Install the Auxiliary Section in Chassis	60

Transmission Overhaul Procedures - Bench Service

Shift Bar Housing

How to Disassemble the Gear Shift Lever	63
How to Assemble the Gear Shift Lever	65
How to Remove the Shift Bar Housing	67
How to Install the Shift Bar Housing	69
How to Disassemble the Shift Bar Housing	71
How to Assemble the Shift Bar Housing	73

Disassemble Auxiliary Section

How to Remove the Auxiliary Section with Tapered Bearings	77
How to Disassemble the Range Cylinder Assembly	80
How to Remove the Auxiliary Countershaft Assembly	83
How to Disassemble the Synchronizer Assembly	86
How to Disassemble the Output Shaft Assembly	87

Assemble Auxiliary Section

How to Assemble the Output Shaft Assembly	92
How to Assemble the Synchronizer Assembly	94
How to Install the Oil Seal	96
How to Assemble the Range Cylinder Assembly	97
How to Install the Countershaft Assemblies	100

Disassemble Front Section

How to Remove the Clutch Housing (with Internal Oil Tube)	106
How to Install the Clutch Housing (with Internal Oil Tube)	108
How to Remove the Standard Torque Auxiliary Drive Gear Assembly	111
How to Disassemble the Upper and Lower Reverse Idler Gear Assembly	112
How to Remove the Upper and Lower Countershaft Bearings	114
How to Remove the Input Shaft and Main Drive Gear	116
How to Remove the Mainshaft Assembly	119
How to Disassemble the Mainshaft Assembly	121
How to Disassemble the Mainshaft Assembly with Low Force Gearing	125
How to Remove the Countershaft Assemblies	127
How to Disassemble the Countershaft Assemblies	129
How to Disassemble the Auxiliary Drive Gear Assembly	132

Assemble Front Section

How to Prepare the Main Case for Assembly	133
How to Assemble the Auxiliary Drive Gear Assembly	134
How to Assemble the Lower Reverse Idler Gear Assembly	136
How to Assemble the Mainshaft Assembly with Low Force Gearing	138
How to Assemble the Countershaft Assemblies	141
How to Install the Auxiliary Countershaft Assembly	144
How to Install the Lower Countershaft Bearings	147
How to Install the Input Shaft and Main Drive Gear	150
Mainshaft Assembly	152
How to Install the Mainshaft Assembly with Selective (Adjustable) Thickness Tolerance Washers	153
How to Install the Mainshaft	161
How to Install the Upper Countershaft Bearings	163
How to Assemble the Upper Reverse Idler Gear Assembly	166
How to Install the Standard Torque Auxiliary Drive Gear Assembly	168

Install Auxiliary Section

How to Install the Auxiliary Section With Tapered Bearings	169
Shim Procedure With A Shim Tool For Tapered Bearings	172
Shim Procedure without a Shim Tool for Tapered Bearings	175

Purpose and Scope of Manual

This manual is designed to provide information necessary to service and repair the Eaton Fuller transmissions listed on the front.

How to use this Manual

The service procedures have been divided into two sections: In-Vehicle Service Procedures and Transmission Overhaul Procedures—Bench Service. In-Vehicle Service Procedures contain procedures that can be performed while the transmission is still installed in the vehicle. Transmission Overhaul Procedures contain procedures that are performed after the transmission has been removed from the vehicle.

The procedure sections are laid out with a general heading at the top outside edge of each page followed by more specific headings and the procedures. To find the information you need in these sections, first go to the section that contains the procedure you need. Then look at the heading at the top and outside edge of each page until you find the one that contains the procedure you need.

Transmission Overhaul Procedures follow the general steps for complete disassembly and then assembly of the transmission.

Note: In some instances the transmission appearance may be different from the illustrations, but the procedure is the same.

Disassemble Precautions

It is assumed in the detailed assembly instructions that the lubricant has been drained from the transmission, the necessary linkage and vehicle air lines disconnected and the transmission has been removed from vehicle chassis. Removal of the gear shift lever housing assembly (or remote control assembly) is included in the detailed instructions (How to Remove the Gear Shift Lever). This assembly **MUST** be detached from the shift bar housing before the transmission can be removed.

Follow closely each procedure in the detailed instructions, make use of the text, illustrations, and photographs provided.

Assemblies

- When disassembling the various assemblies, such as the mainshaft, countershafts, and shift bar housing, lay all parts on a clean bench in the same sequence as removed. This procedure will simplify assembly and reduce the possibility of losing parts.

Bearings

- Carefully wash and lubricate all usable bearings as removed and protectively wrap until ready for use. Remove bearings planned to be reused with pullers designed for this purpose.

Cleanliness

- Provide a clean place to work. It is important that no dirt or foreign material enters the unit during repairs. Dirt is an abrasive and can damage bearings. It is always a good practice to clean the outside of the unit before starting the planned disassembly.

Input Shaft

- The input shaft can be removed from the transmission without removing the countershafts, mainshaft, or main drive gear. Special procedures are required and provided in this manual.

Snap Rings

- Remove snap rings with pliers designed for this purpose. Snap rings removed in this manner can be reused, if they are not sprung or loose.

Introduction

When Using Tools to Move Parts

- Always apply force to shafts, housings, etc., with restraint. Movement of some parts is restricted. Never apply force to driven parts after they stop solidly. The use of soft hammers, soft bars, and mauls for all disassembly work is recommended.

Inspection Precautions

Before assembling the transmission, check each part carefully for abnormal or excessive wear and damage to determine reuse or replacement. When replacement is necessary, use only genuine Eaton® Fuller® Transmission parts to assure continued performance and extended life from your unit.

Since the cost of a new part is generally a small fraction of the total cost of downtime and labor, avoid reusing a questionable part which could lead to additional repairs and expense soon after assembly. To aid in determining the reuse or replacement of any transmission part, consideration should also be given to the unit's history, mileage, application, etc.

Recommended inspection procedures are provided in the following checklist.

Bearings

- Wash all bearings in clean solvent. Check balls, rollers, and raceways for pitting, discoloration, and spalled areas. Replace bearings that are pitted, discolored, spalled, or damaged during disassembly.
- Lubricate bearings that are not pitted, discolored, or spalled and check for axial and radial clearances.
- Replace bearings with excessive clearances.
- Check bearing fit. Bearing inner races should be tight to shaft; outer races slightly tight to slightly loose in case bore. If the bearing spins freely in the bore the case should be replaced.

Bearing Covers

- Check covers for wear from thrust of adjacent bearing. Replace covers damaged from thrust of bearing outer race.
- Check cover bores for wear. Replace those worn or oversized.

Clutch Release Parts

- Check clutch release parts. Replace yokes worn at cam surfaces and bearing carrier worn at contact pads.
- Check pedal shafts. Replace those worn at bushing surfaces.

Gears

- Check gear teeth for frosting and pitting. Frosting of gear teeth faces presents no threat of transmission failure. Often in continued operation of the unit, frosted gears "heal" and do not progress to the pitting stage. In most cases, gears with light to moderate pitted teeth have considerable gear life remaining and can be reused, but gears in the advanced stage of pitting should be replaced.
- Check for gears with clutching teeth abnormally worn, tapered, or reduced in length from clashing during shifting. Replace gears found in any of these conditions.
- Check axial clearance of gears.

Gear Shift Lever Housing Assembly

- Check spring tension on shift lever. Replace tension spring if lever moves too freely.
- If housing is disassembled, check gear shift lever bottom end and shift finger assembly for wear. Replace both gears if excessively worn.

Gray Iron Parts

- Check all gray iron parts for cracks and breaks. Replace parts found to be damaged.

Oil Return Threads and Seals

- Check oil return threads on the input shaft. If return action of threads has been destroyed, replace the input shaft.
- Check oil seal in rear bearing cover. If sealing action of lip has been destroyed, replace seal.

O-Rings

- Check all O-rings for cracks or distortion. Replace if worn.

Reverse Idler Gear Assemblies

- Check for excessive wear from action of roller bearings.

Shift Bar Housing Assembly

- Check for wear on shift yokes and blocks at pads and lever slot. Replace excessively worn parts.
- Check yokes for correct alignment. Replace sprung yokes.
- Check lockscrews in yoke and blocks. Tighten and rewire those found loose.
- If housing has been disassembled, check neutral notches of shift bars for wear from interlock balls.

Sliding Clutches

- Check all shift yokes and yoke slots in sliding clutches for extreme wear or discoloration from heat.
- Check engaging teeth of sliding clutches for partial engagement pattern.

Splines

- Check splines on all shafts for abnormal wear. If sliding clutch gears, companion flange, or clutch hub has wear marks in the spline sides, replace the specific shaft effected.

Synchronizer Assembly

- Check synchronizer for burrs, uneven and excessive wear at contact surface, and metal particles.
- Check blocker pins for excessive wear or looseness.
- Check synchronizer contact surfaces on the synchronizer cups for wear.

Washers

- Check surfaces of all washers. Washers scored or reduced in thickness should be replaced.

Assembly Precautions

Make sure that case interiors and housings are clean. It is important that dirt and other foreign materials are kept out of the transmission during assembly. Dirt is an abrasive and can damage polished surfaces of bearings and washers. Use certain precautions, as listed below, during assembly.

Axial Clearances

- Maintain original axial clearances of .006" to .015" for mainshaft gears.

Bearings

- Use a flange-end bearing driver for bearing installation. These special drivers apply equal force to both bearing races, preventing damage to balls/rollers and races while maintaining correct bearing alignment with bore and shaft. Avoid using a tubular or sleeve-type driver, whenever possible, as force is applied to only one of the bearing races.

Introduction

Capscrews

- To prevent oil leakage and loosening, use Eaton Fuller sealant #71205 on all capscrews.

Gaskets

- Use new gaskets throughout the transmission as it is being rebuilt. Make sure all gaskets are installed. An omission of any gasket can result in oil leakage or misalignment of bearing covers.

Initial Lubrication

- Coat all limit washers and shaft splines with Lubricant during assembly to prevent scoring and galling of such parts.

O-Rings

- Lubricate all O-rings with silicon lubricant.

Universal Joint Companion Flange or Yoke

- Pull the companion flange or yoke tightly into place with the output shaft nut, using 450-500 lbs. ft. of torque. Make sure the speedometer drive gear or a replacement spacer of the same width has been installed. Failure to pull the companion flange or yoke tightly into place can result in damage to the mainshaft rear bearing.

IMPORTANT: See the appropriate Illustrated Parts Lists (specified by model number) to ensure that proper parts are used during assembly of the transmission.

Serial Tag Information and Model Nomenclature

Transmission model designation and other transmission identification information are stamped on the serial tag. To identify the transmission model and serial number, locate the tag on the transmission and then locate the numbers as shown. Figure 1-1 below shows the tag which is located on the transmission.

When calling for service assistance or parts, have the model and serial numbers handy

Do not remove or destroy the transmission identification tag!

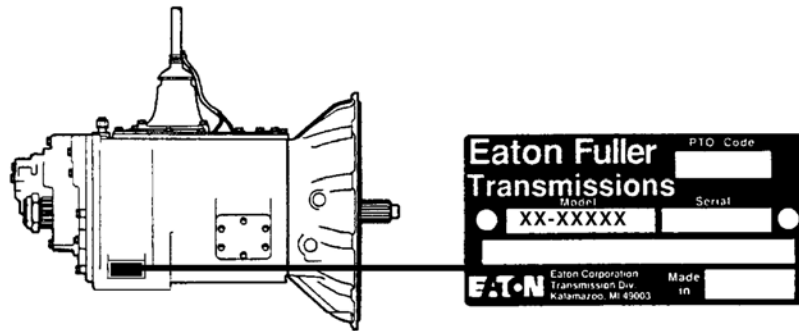
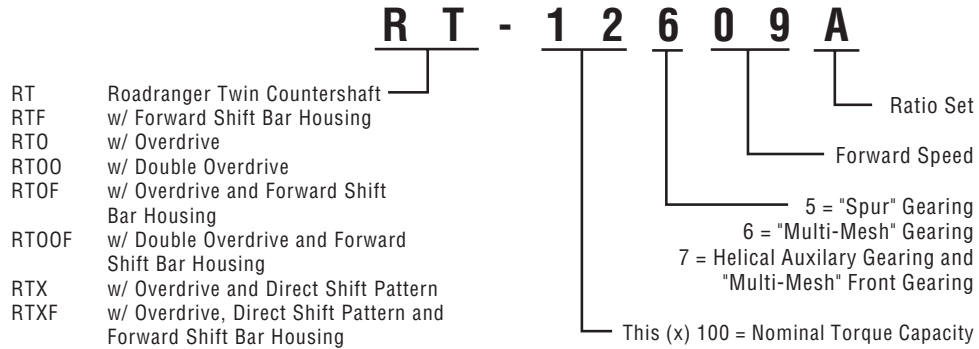

Fig 1-1

Transmission Tag and Location

Model Number

The model number gives basic information about the transmission and is explained below. Use this number when calling for service assistance or replacement parts.



Serial Number

The serial number is the sequential identification number of the transmission. Before calling for service assistance, write the number down as it may be needed.

Bill of material or Customer number

This number may be located below the model and serial numbers. It is a reference number used by Eaton®.

Model Designations

Model Options

Torque Rating

The torque rating of the transmission specified in the model number is the input torque capacity in lb. ft. Various torque ratings are available. For more information, call the Roadranger Help Desk at 1-800-826-HELP (4357).

Two types of shift bar housings are available for this transmission. Both are described and shown below.

Shift Bar housings

Standard: The standard shift bar housing has a gear shift lever opening that is located toward the rear of the transmission. The housing is shown in figure 1-2.

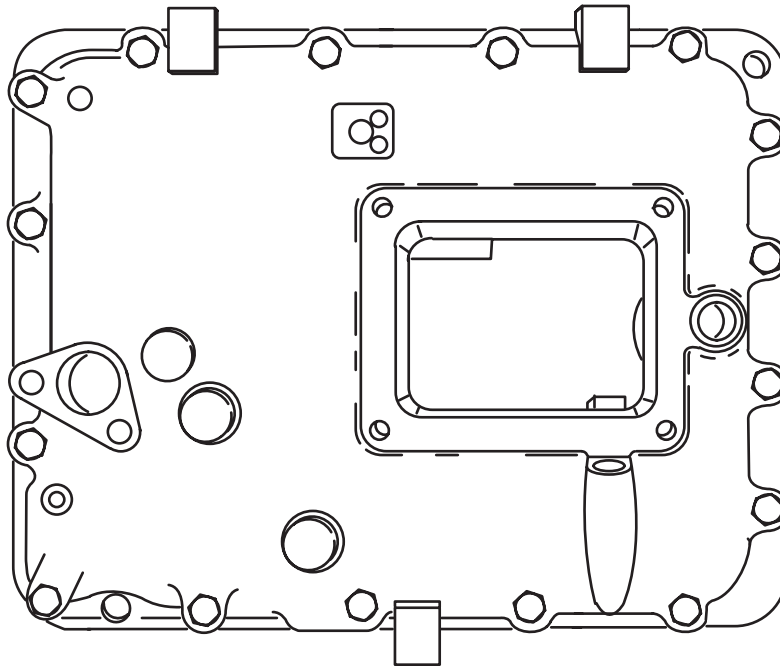

Fig 1-2

Forward Opening: The forward opening shift bar housing has a gear shift lever opening located three inches closer to the front of the transmission than the standard opening. This forward design allows greater flexibility in mounting the transmission and is indicated by an “F” in the model number. The housing is shown in figure1-3.

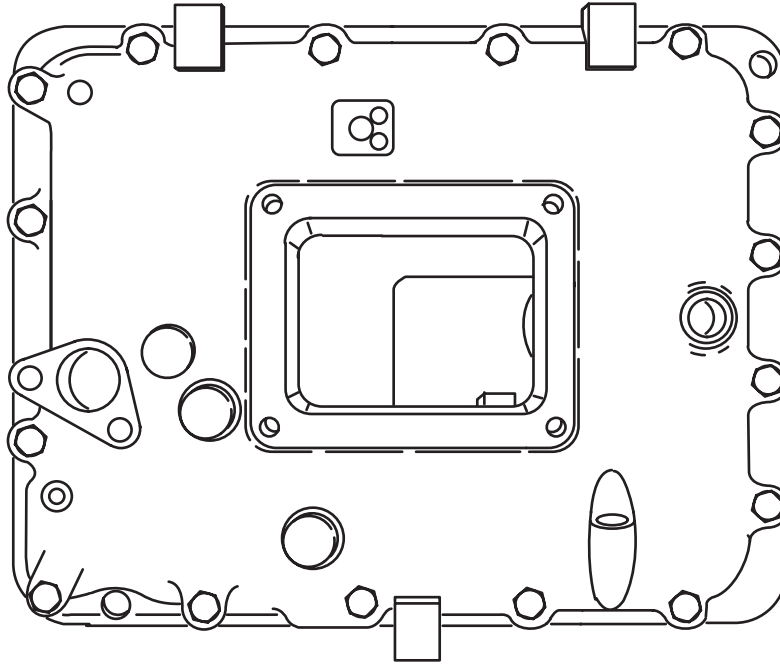

Fig 1-3

Lubrication Pumps

Two types of lubrication pumps are available for use on this transmission and are described below:

PTO Driven: A PTO driven pump is externally mounted on the 6 or 8 bolt PTO openings and driven off the PTO gear.

Auxiliary Countershaft: An auxiliary countershaft pump is mounted on the rear of the transmission and driven off the auxiliary countershaft.

Power Take Off (PTO) Usage

PTOs can be mounted in the following ways:

6 or 8 Bolt: The 6 or 8 bolt openings are standard with the transmission. The PTO is mounted to the opening and driven from the PTO gear on the front countershaft.

Thru-Shaft: The thru-shaft PTO mounts on the rear of the transmission. It requires a special auxiliary housing and main case countershaft with internal splines.

Model Designations

Gear Ratios

Model	Speed Gear Ratios											Relative Speed PTO Gear To Input R.P.M.		Length In / mm *	Weight Lbs/ Kgs **	Oil Cap. Pints / Liters ***
	1st	2nd	3rd	4th	5th	6th	7th	8th	9th	10	Reverse	Right	Btm			
RT-11709H	13.29	9.16	6.53	4.80	3.57	2.56	1.83	1.34	-	-	3.89/ 13.89	.696	.696	28.90 / 734.1	606 / 275	25.5 / 12
RT-11710B	14.78	11.00	8.17	6.00	4.46	3.31	2.46	1.83	1.34	1.00	3.38/ 14.78	.788	.788	28.9 / 734.1	604 / 274	26 / 12
RT-12709H	13.29	9.16	6.53	4.80	3.57	2.56	1.83	1.34	-	-	3.89/ 13.89	.696	.696	28.90 / 734.1	606 / 275	25.5 / 12
RT-12710B	14.78	11.00	8.17	6.00	4.46	3.31	2.46	1.83	1.34	1.00	3.38/ 14.78	.788	.788	28.9 / 734.1	606 / 275	26 / 12
RT-13709H	13.29	9.16	6.53	4.80	3.57	2.56	1.83	1.34	-	-	3.89/ 13.89	.696	.696	28.90 / 734.1	606 / 275	25.5 / 12
RT-13710B	14.78	11.00	8.17	6.00	4.46	3.31	2.46	1.83	1.34	1.00	3.38/ 14.78	.788	.788	28.9 / 734.1	611 / 277	26 / 12
RT-14709H	13.29	9.16	6.53	4.80	3.57	2.56	1.83	1.34	-	-	3.89/ 13.89	.696	.696	28.90 / 734.1	606 / 275	25.5 / 12
RT-14710B	14.78	11.00	8.17	6.00	4.46	3.31	2.46	1.83	1.34	1.00	3.38/ 14.78	.788	.788	29.5 / 749.3	624 / 283	26 / 12
RTX-11709H	10.55	7.41	5.23	3.79	2.77	1.95	1.38	1.00	-	-	2.99/ 11.33	.788	.788	28.91 / 743.3	664 / 301	25.5 / 12
RTX-11710B	10.99	8.18	6.07	4.46	3.32	2.46	1.83	1.36	1.00	.74	2.52/ 11.23	.788	.788	28.9 / 734.1	604 / 274	26 / 12
RTX-12709H	10.55	7.41	5.23	3.79	2.77	1.95	1.38	1.00	-	-	2.99/ 11.33	.788	.788	28.91 / 743.3	664 / 301	25.5 / 12
RTX-12710B	10.99	8.18	6.07	4.46	3.32	2.46	1.83	1.36	1.00	.74	2.52/ 11.23	.788	.788	28.9 / 734.1	606 / 275	26 / 12
RTX-13709H	10.55	7.41	5.23	3.79	2.77	1.95	1.38	1.00	-	-	2.99/ 11.33	.788	.788	28.91 / 743.3	664 / 301	25.5 / 12
RTX-13710B	10.99	8.18	6.07	4.46	3.32	2.46	1.83	1.36	1.00	.74	2.52/ 11.23	.788	.788	28.9 / 734.1	611 / 277	26 / 12
RTX-14709H	10.55	7.41	5.23	3.79	2.77	1.95	1.38	1.00	-	-	2.99/ 11.33	.788	.788	28.91 / 743.3	664 / 301	25.5 / 12
RTX-14710B	10.99	8.18	6.07	4.46	3.32	2.46	1.83	1.36	1.00	.74	2.52/ 11.23	.788	.788	29.5 / 749.3	624 / 283	26 / 12
RTX-16709H	10.55	7.41	5.23	3.79	2.77	1.95	1.38	1.00	-	-	2.99/ 11.33	.788	.788	28.91 / 743.3	664 / 301	25.5 / 12
RTX-16709B	12.46	7.41	5.23	3.79	2.77	1.95	1.38	1.00	-	-	3.43/ 13.03	.788	.788	29.50 / 749.3	693 / 314	25.5 / 12

* **Lengths** measured from face of clutch housing to front bottoming surface of companion flange or yoke.

** **Weights** include SAE No.1 cast iron clutch housing and standard controls (control valve, gear shift lever and housing assembly, and air lines), less clutch release parts. All weights are approximate.

*****Oil Capacities** are approximate, depending on inclination of engine and transmission. Always fill transmission with proper grade and type of lubricant to level of filler opening. See "Lubrication" on page 14.

Torque Ratings

Correct torque application is extremely important to assure long transmission life and dependable performance. Overtightening or under-tightening can result in a loose installation and, in many instances, eventually cause damage to transmission gears, shafts or bearings. Use of a thread sealer/locking compound is recommended for all capscrews. Do not torque capscrews dry.

Torque - Front Section

Description	Torque Value lbs. ft.	Thread Size	Additional Comments
1 Main Drive Gear Bearing Nut	250-300		Apply Loctite grade 277 sealant. Stake to input shaft.
6 Front Bearing Cover Capscrews	35-45	3/8" - 16	Apply Loctite 242 to threads.
6 Clutch Housing Nuts	Aluminum housing: 170-175 Cast Iron Housing: 180-190	5/8" - 18	Use lockwashers.
4 Slave Air Valve Capscrews	8-12	1/4" - 20	Apply Loctite 242 to threads.
1 Neutral Signal Switch Plug	35-50	3/4" - 16	
5 Shift Block and Yoke Lockscrews	35-45	7/16" - 20	Secure with lockwire.
16 Shift Bar Housing and 4 Shift Lever Housing Capscrews	35-45	3/8" - 16	Apply Loctite 242 to threads.
1 Reverse Signal Switch Plug	35-50	9/16" - 18	
2 Support Stud Nuts	170-185	5/8" - 18	Use lockwashers.
1 Oil Drain Plug	45-55	3/4" Pipe	
6 Mainshaft Rear Bearing Retainer Capscrews	35-45	3/8" - 16	Secure with lockwire.
1 Oil Fill Plug	25-35	1-1/4" Pipe	
2 Reverse Idler Shaft Nuts	50-60	5/8" - 18	
6 Small PTO Cover Capscrews	20-25	3/8" - 16	Apply Loctite 242 to threads.
8 Large PTO Cover Capscrews	50-65	7/16" - 14	Apply Loctite 242 to threads.
4 Hand Hole Cover Capscrews	20-25	5/16" - 18	
2 Countershaft Front Bearing Retainer Capscrews	90-120	5/8" - 18	Secure with lockwire.
4 Clutch Housing Capscrews	Aluminum housing: 70-75 Cast Iron Housing: 90-100	1/2" - 13	Use lockwashers.

Specifications

Torque - Auxiliary Section

Description	Torque Value lbs. ft.	Thread Size	Additional Comments
2 Air Filter/Regulator Mounting Capscrews	8-12	1/4" - 20	Apply Loctite 242 to threads.
1 Range Cylinder Shift Bar Nut	70-85	5/8" - 18	
2 Range Shift Yoke Capscrews	50-65	1/2" - 20	Secure with lockwire.
6 Mainshaft Rear Bearing Cover Capscrews	35-45	3/8" - 16	Apply Loctite 242 to threads.
4 Range Cylinder Mounting Capscrews	35-45	3/8" - 16	Apply Loctite 242 to threads.
4 Range Cylinder Cover Capscrews	35-45	3/8" - 16	Apply Loctite 242 to threads.
8 Countershaft Rear Bearing Cover Capscrews	35-45	3/8"-16	Apply Loctite 242 to threads.
1 Speedometer Housing Plug	35-50	13/16" - 20	Apply Loctite 242 to threads.
19 Auxiliary Housing Capscrews	35-45	3/8" - 16	Apply Loctite 242 to threads.
1 Output Shaft Nut	450-500	2" - 16	Oiled at vehicle installation.

Lubrication

Proper lubrication procedures are the key to a good all-around maintenance program.

Fuller® Transmissions are designed so that the internal parts operate in an oil circulating bath created by the motion of the gears and shafts.

All parts will be properly lubricated if these procedures are closely followed:

- Maintain oil level. Inspect regularly.
- Follow maintenance interval chart.
- Use the correct grade and type of oil.
- Buy from a reputable dealer.

Maintain Proper Oil Level

Make sure oil is level with the filler opening. Being able to reach oil with your finger does not mean oil is at proper level. **(One inch of oil level is about one gallon of oil.)**

When adding oil, never mix engine oils and gear oils in the same transmission.

Additives and friction modifiers must not be introduced.

Buy from a reputable dealer.

The use of lubricants not meeting requirements will affect warranty coverage.

Lubrication Information

For additional lubrication information and lube intervals, see TCMT0021 or call 1-800-826-HELP (4357).

For a list of approved lubricants, see TCMT0020 or call 1-800-826-HELP (4357).

Oil Level

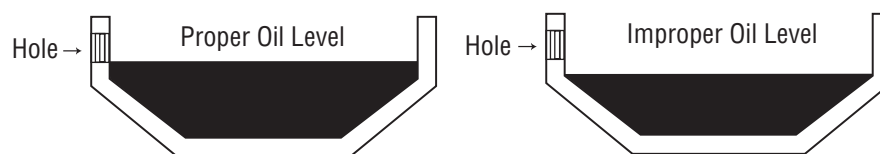

Oil Filter

For transmissions equipped with oil filter, P/N 4304827.

- For highway use - Inspect filter for leaks or damage replace as necessary.
- For off-highway use - Change filter every two years.

Lubrication

If your vehicle has a transmission oil filter, you must change the filter when fluid or lubricant is changed.

Transmission Operating Angles

If the transmission operating angle is more than 12 degrees, improper lubrication will occur. The operating angle is the transmission mounting angle in the chassis plus the percent of upgrade (expressed in degrees). For operating angles over 12 degrees, the transmission must be equipped with an oil pump or cooler kit to insure proper lubrication.

Operating Temperatures with Oil Coolers

The transmission must not be operated consistently at temperatures above 250° F. Operation at temperatures above 250°F [121°C] causes loaded gear tooth temperatures to exceed 350°F [177°C] which will ultimately destroy the heat treatment of the gears. If the elevated temperature is associated with an unusual operating condition that will reoccur, a cooler should be added, or the capacity of the existing cooling system increased.

The following conditions in any combination can cause operating temperatures of over 250° F [121°C]:

- Operating consistently at slow speed.
- High ambient temperatures.
- Restricted air flow around transmission.
- Use of engine retarder.
- High horsepower operation.

Note: Transmission coolers must be used to reduce the operating temperatures when the above conditions are encountered.

Oil Cooler Chart

Transmission Oil Coolers are:
Recommended
• With engines of 350 H.P. and above.
Required
• With engines 399 H.P. and above and GCW's over 90,000 lbs.
• With engines 399 H.P. and above and 1400 lb. ft. or greater torque.
• With engines 1500 lb. ft. and above

Tool Information

Some repair procedures pictured in this manual show the use of specialized tools. Their actual use is recommended as they make transmission repair easier, faster, and prevent costly damage to critical parts.

But for the most part, ordinary mechanic's tools such as socket wrenches, screwdrivers, etc., and other standard shop items such as a press, mauls and soft bars are all that is needed to successfully disassemble and reassemble any Eaton Fuller Transmission.

Recommended Tools

The following tables list and describe the typical tools required to properly service this model transmission above and beyond the necessary basic wrenches, sockets, screwdrivers, and prybars.

General Tools

The following tools are available from several tool manufacturers such as Snap-On, Mac, Craftsman, OTC, and many others.

TOOL	PURPOSE
0 - 100 lbs. ft. 1/2" drive Torque Wrench.	General torquing of fasteners (typically 15-80 lbs. ft.).
0 - 600 lbs. ft. 3/4" or 1" drive Torque Wrench.	Torquing of output nut to 500 lbs. ft.
0 - 50 lbs. in. 3/8" drive Torque Wrench.	General torquing of fasteners.
0 - 30 lbs. in. 1/4" drive Torque Wrench.	Torquing of capscrews to 7 lbs. in. during auxiliary countershaft bearing endplay setting procedure.
70 MM or 2-2/4" Socket - Standard Depth	To remove the output yoke nut.
Large Brass Drift	Used to protect shafts and bearings during removal.
Large Dead Blow Hammer or Maul	To provide force for shaft and bearing removal.
Snap Ring Pliers - Large Standard External	To remove the snap rings at the auxiliary drive gear, input shaft bearing, and countershaft bearings.
Feeler Gauges	To set mainshaft washer endplay and auxiliary tapered bearing endplay.
Rolling Head (Crow's Foot) Prybar	To remove the auxiliary drive gear bearing.
(2) Air Pressure Gauges 0-100 PSI (0-1034 kPa)	To troubleshoot and verify correct operation of air system.
Universal Bushing Driver	To remove and install clutch housing bushings. Bushing OD = 1.125", ID = 1.000"

Tool Information

Eaton Fuller Model Special Tools

The following special tools are designed for this Eaton® Fuller® transmission. The addresses and phone numbers of the tool suppliers are listed after the table. This list is provided as a convenience to our customers. These tools are manufactured by independent companies with no relationship to Eaton® Fuller®. Eaton® Fuller® does not warrant the fit or function of the listed tools. To obtain the tools, contact the tool supplier directly.

REF. NO.	TOOL	PURPOSE	G & W TOOL NO.	GREAT LAKES TOOL NO.	OTC TOOL NO.
T1	Output Yoke Puller	May be required to remove a rusted output yoke.	SP-450		7075
T2	Auxiliary Section Hanger	To support, or hang, the auxiliary section in the horizontal position.	G-40	T-125	5061
T3	Auxiliary Countershaft Support and Shim Tool	To hold the auxiliary countershafts in position while installing the auxiliary section in the horizontal position. Also to simplify the checking and setting of the auxiliary countershaft bearing endplay.	G-250	T-311	5062
T4	Shift Lever Spring Installation Tool (Tension Spring Driver)	To install the shift tower tension spring.	G-116	T-170	
T5	Slide Hammer	To remove the output seal and reverse idler shafts. Requires 1/2"-13 threads. (Optional, idler shaft can be driven out from front.)	G-70	T-150	1155 Slide Hammer / 8007 1/2" -13 Adapter
T6	Bearing Puller	To remove front section countershaft bearings.	G-10 or G-15	T-100	7070A Kit
T7	Bearing Driver	To install front section countershaft bearings (3.97" OD, 1.78" ID).	G200 Kit	T-101 Kit	
T8	Bearing Driver	To install the front countershaft rear bearings (3.5" OD, 1.6" ID)	G200 Kit	T-101 Kit	
T9	Countershaft Support Tools (2)	To support and locate the front section countershafts during bearing removal and installation.	G-50 / G-51 / G-58	T-145S	7109
T10	Input Bearing Driver	To install input bearing on input shaft.	G-35	T-120	5066 (2" shaft)
T11	Bearing Puller	To remove the auxiliary countershaft tapered bearings.	G-247A / G-247G		1123 / 927
T12	Bearing Driver	To install the auxiliary countershaft tapered bearings.	G200 Kit	T-101 Kit	
T13	Output Seal Removal Tool	To remove the output seal in chassis. Can use slide hammer.			Use 27315 hook with 1155 slide hammer

* Tool numbers are referenced in the service procedures.

Tool Information

REF. NO.	TOOL	PURPOSE	G & W TOOL NO.	GREAT LAKES TOOL NO.	OTC TOOL NO.
T14	Auxiliary Section Removal Adapter Plate	To attach transmission jack to auxiliary section for auxiliary section removal in chassis.	G-115		49611 (Used with OTC transmission jack P/N 5019.)
T15	Mainshaft Hook	To assist in lifting of mainshaft from front section.	G-225	T-165	
T16	Input Bearing Puller	To remove input bearing.	G-38		7070A Kit
T17	Bearing Race Puller	To remove the auxiliary countershaft tapered bearing outer races.	G-247B attached to G-70 impact puller	T-157 with T-150	7136 puller attached to 1155 slide hammer
T18	Bearing Race Installer	To install the auxiliary countershaft tapered bearing outer races.	G-200 Kit	T-101 Kit	27524/27530 discs used with 27488 handle and 10020 screw.

* Tool numbers are referenced in the service procedures.

Shop Equipment

20 Ton capacity press	To press countershaft gears from countershaft.
-----------------------	--

Special Tools Manufacturers

Below are the addresses and phone numbers of the companies that make tools specifically for Eaton® Fuller® transmissions.

G and W Tool Company

1105 E. Louisville
Broken Arrow, OK 74012-5724
800-247-5882

Great Lakes Tool

8530 M-89
Richland, MI 49083
800-877-9618

O.T.C.

655 Eisenhower Dr.
Owatonna, MN 55060-1171
800-533-6127

The specialized tools can be obtained from a tool supplier or made from tool prints as required by the individual user. Detailed Eaton Fuller Transmission Tool Prints are available upon request by writing to:

Eaton Corporation
Truck Components Operations
Technical Service
P.O. Box 4013
Kalamazoo, Michigan 49003

Tool Information

Eaton Aftermarket Parts

The following tools are available through Eaton Aftermarket Parts. To obtain any of the tools listed, contact your local Eaton® parts distributor.

TOOL	PURPOSE	EATON PART NUMBER
5/32" Air Line Release Tool	To remove 5/32" air lines from push-to-connect fittings.	P/N 4301157 included in kit K-2394.
Air Line Cutting Tool	To cut plastic air lines smoothly and squarely.	P/N 4301158 included in kit K-2394.
Output Seal Driver	To install output seal.	For 7 series: Eaton P/N 5564501 driver. For 9 series: Use Eaton P/N 5564509 adapter with 5564501 driver. Both parts included in Complete Eaton Seal Kit P/N K-3651.
Output Seal Slinger Driver	To install output seal slinger.	For 7 series: Eaton P/N 71223. For 9 series: Eaton P/N 4303829.

Preventative Maintenance

Everyday there are countless vehicles operating over the highways with transmissions in such a neglected mechanical condition, they can be referred to as failures looking for a place to break down. They lack a proper and organized preventive maintenance program.

Preventive maintenance is a general term which applies to all procedures necessary to have maximum life and satisfactory service at the lowest possible cost, short of removing and repairing the unit.

A number of conditions contrary to good preventive maintenance can generally be pointed to when inspecting a failed transmission. Taking a few minutes every so many hours or miles to do a few simple checks could help avoid eventual breakdown or reduce the repair cost. If the transmission is not cared for, it will breakdown.

Preventative Maintenance Check Points

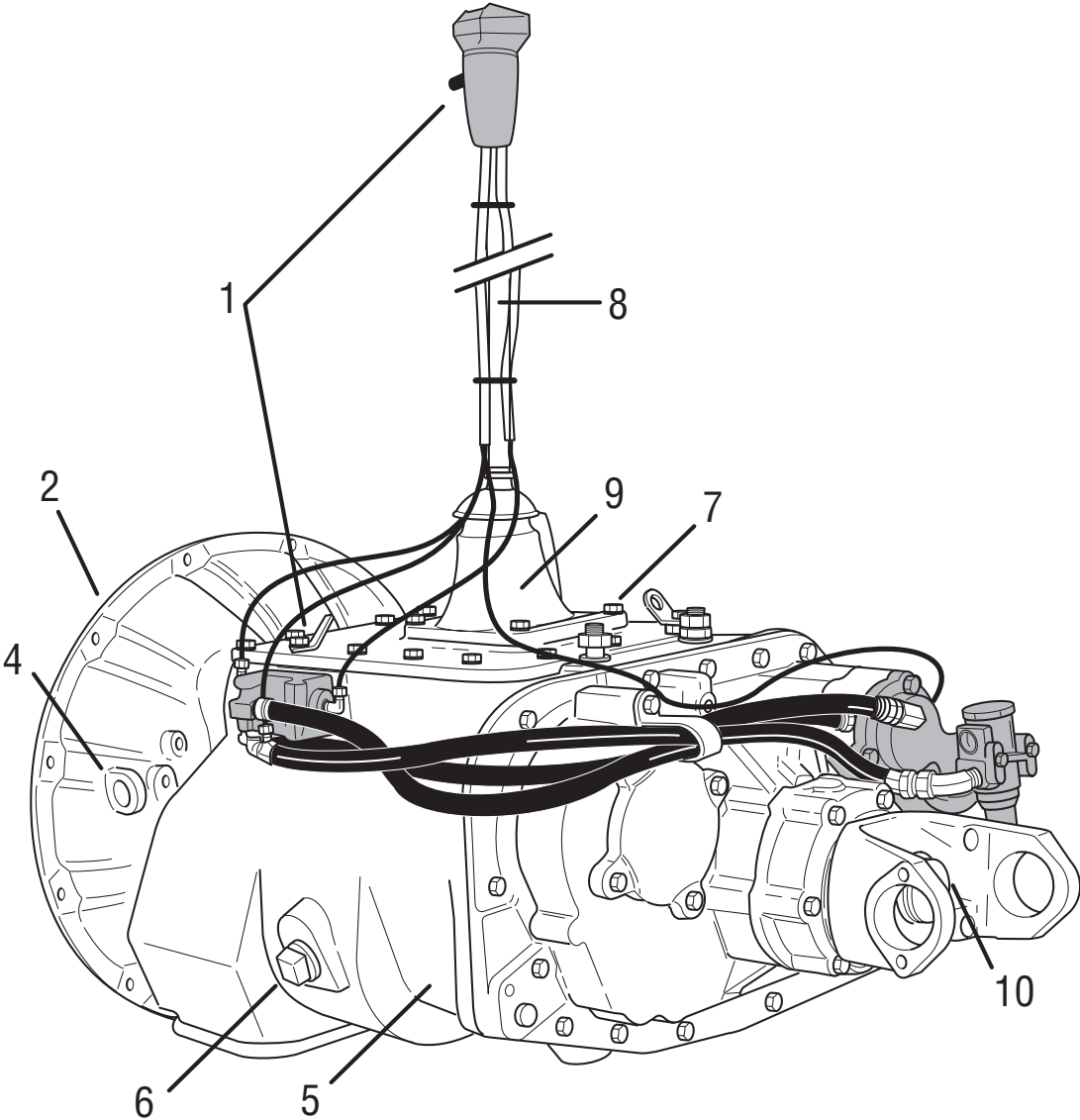

Note: Transmission appearance may differ, the procedure is the same.

Preventative Maintenance

Air System and Connections (1)

- Check for leaks, worn air lines, loose connections and capscrews.

Clutch Housing Mounting (2)

- Check all capscrews of clutch housing flange for looseness.

Clutch Release Bearing (Not Shown)

- Remove hand hole cover and check radial and axial clearance in release bearing.
- Check relative position of thrust surface of release bearing with thrust sleeve on push-type clutches.

Clutch Pedal Shaft and Bores (4)

- Pry upward on shafts to check wear.
- If excessive movement is found, remove clutch release mechanism and check bushings on bores and wear on shafts. See OEM literature.

Lubricant (5)

- Change at specified service intervals.
- Use only the types and grades as recommended. See "Recommended Lubrication Chart".

Filler and Drain Plugs (6)

- Remove filler plugs and check level of lubricant at specified intervals. Tighten fill and drain plugs securely.

Capscrews and Gaskets (7)

- For applicable models, check all capscrews, especially those on PTO covers and rear bearing covers for looseness which would cause oil leakage.
- Check PTO opening and rear bearing covers for oil leakage due to faulty gasket.

Gear Shift Lever (8)

- Check for looseness and free play in housing. If lever is loose in housing, proceed with Check No. 9.

Gear Shift Lever Housing Assembly (9)

- If present, remove air lines at air valve or slave valve. Remove the gear shift lever housing assembly from the transmission.
- Check the tension spring and washer for set and wear.
- Check the gear shift lever spade pin and slot for wear.
- Check bottom end of gear shift lever for wear and check slot of yokes and blocks in shift bar housing for wear at contact points with shift lever.

Checks With Drive Line Dropped

Universal Joint Companion Flange or Yoke Nut (10)

- Check for tightness. Tighten to recommended torque.

Output Shaft (Not Shown)

- Pry upward against output shaft to check radial clearance in mainshaft rear bearing.

Checks With Universal Joint Companion Flange or Yoke Removed

Note: If necessary, use solvent and shop rag to clean sealing surface of companion flange or yoke. Do not use crocus cloth, emery paper, or other abrasive materials that will mar surface finish.

Splines on Output Shaft (Not Shown)

- Check for wear from movement and chucking action of the universal joint companion flange or yoke.

Mainshaft Rear Bearing Cover (13)

- Check oil seal for wear.

Preventative Maintenance

Oil Leak Inspection Process

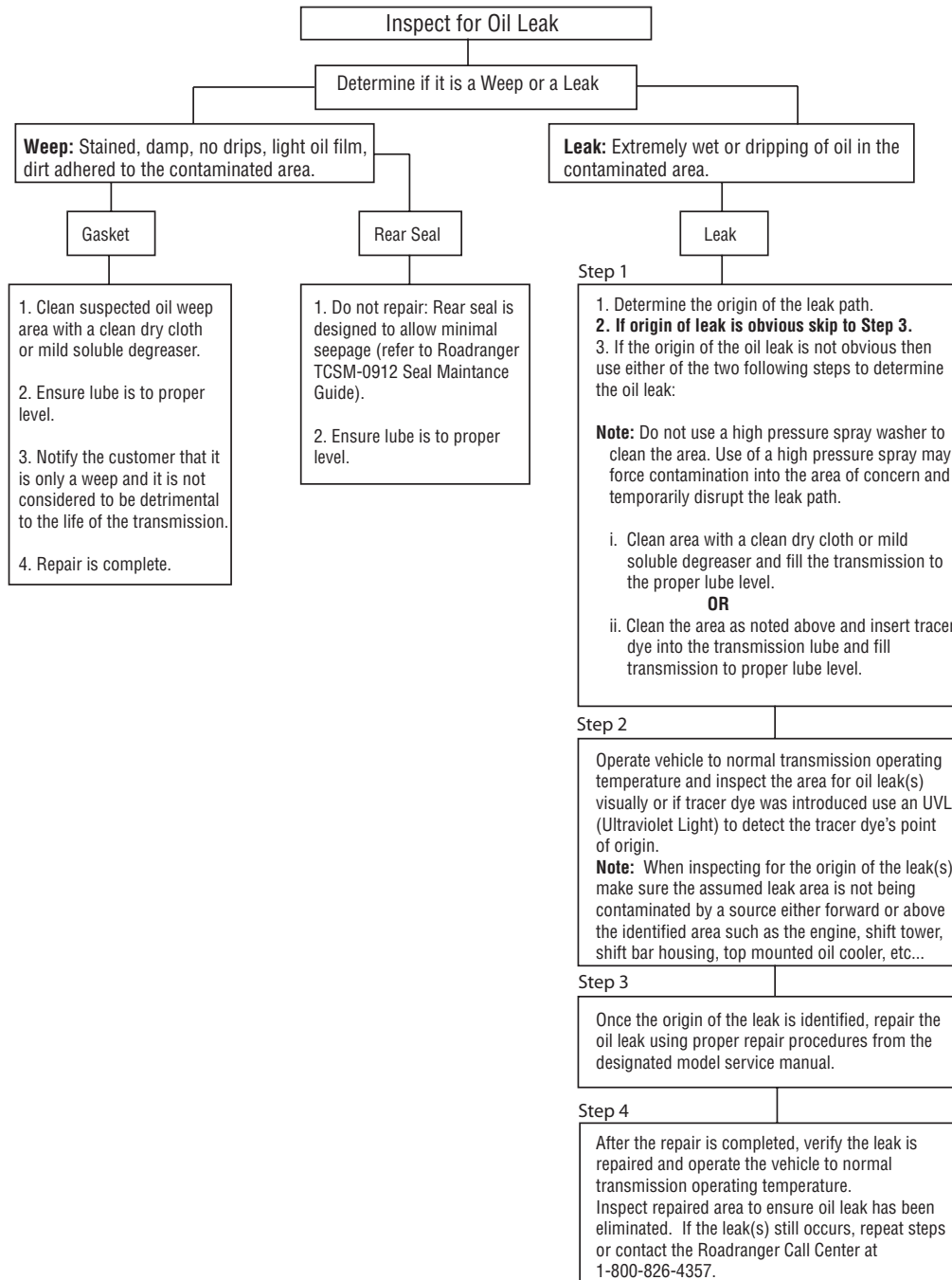

Inspection

Part to Inspect	What to Check For	Action to be Done
Speedometer Connections	Speedometer cables should not be loose.	Applied hydraulic thread sealant #71208 to threads. Torque speedometer sleeve to 35-50 lbs. ft.
	Should be an O-ring or gasket between the mating speedometer sleeve and the rear bearing cover.	Replace the O-ring/gasket if damaged or missing.
Rear Bearing Cover Capscrews, Gasket, and Nylon Collar	Check retaining capscrews for tightness.	Apply Eaton Sealant #71205 to the cap-screw threads. Torque capscrews to 35-45 lbs. ft.
	Verify nylon collar and gasket are installed at the chamfered hole, aligned near the mechanical speedometer opening.	Use new parts if need to replace. Apply Eaton Sealant #71205 to the cap-screw threads. Torque capscrews to 35-45 lbs. ft.
	Verify that a rear bearing cover gasket is in place.	Install a new gasket if rear bearing cover was removed.
Output Yoke Retaining Nut	Check the output yoke retaining nut for tightness.	Torque the output yoke retaining nut to 450-500 lbs. ft. Do not over torque the output nut.
PTO Covers and Openings	Check the capscrews for tightness.	Apply Eaton Sealant #71205 to the cap-screw threads. Tighten 6 bolt PTO capscrews to 35-45 lbs. ft. Tighten 8 bolt PTO capscrews to 50-65 lbs. ft.
Gray Iron Parts	Check front bearing cover, front case, shift bar housing, rear bearing cover, and clutch housing for cracks or breaks.	Replace parts found to be damaged.
Front Bearing Cover	Check return threads for damage.	If threads damaged, replace the input shaft.
	Check the capscrews for tightness.	Tighten the capscrews to 35-45 lbs. ft.
Oil Cooler and Oil Filter	Check all connectors, fittings, hoses, and filter element for tightness.	Tighten any loose fittings.
Oil Drain Plug, Oil Fill Plug	Check the oil drain plug and the oil fill plug for leakage.	Torque the oil drain plug to 45-55 lbs. ft.
		Torque the oil fill plug to 60-70 lbs. ft.

Power Flow

Power Flow

The transmission must efficiently transfer the engine's power, in terms of torque, to the vehicle's rear wheels. Knowledge of what takes place in the transmission during torque transfer is essential when troubleshooting and making repairs.

Front Section Power Flow (All Models)

- Power (torque) from the vehicle's engine is transferred to the transmission's input shaft. (1)
- Splines of input shaft engage internal splines in hub of main drive gear. (2)
- Torque is split between the two countershaft drive gears. (3)
- Torque is delivered along both countershafts to mating countershaft gears of "engaged" mainshaft gear. The cross section views illustrate 1st/6th speed gear engagement. (4)
- Internal clutching teeth in hub of engaged mainshaft gear transfers torque to mainshaft through sliding clutch. (5)
- Mainshaft transfers torque directly to rear auxiliary drive gear. (6)

Auxiliary Section Power Flow: LO RANGE (All Models)

- The auxiliary drive gear splits torque between the two auxiliary countershaft drive gears. (7)
- Torque is delivered along both auxiliary countershafts to the "engaged" LO RANGE gear on range mainshaft or output shaft. (8)
- Torque is transferred to range mainshaft or output shaft through sliding clutch. (9)
- Torque is delivered to driveline as LO RANGE 1st. (10)

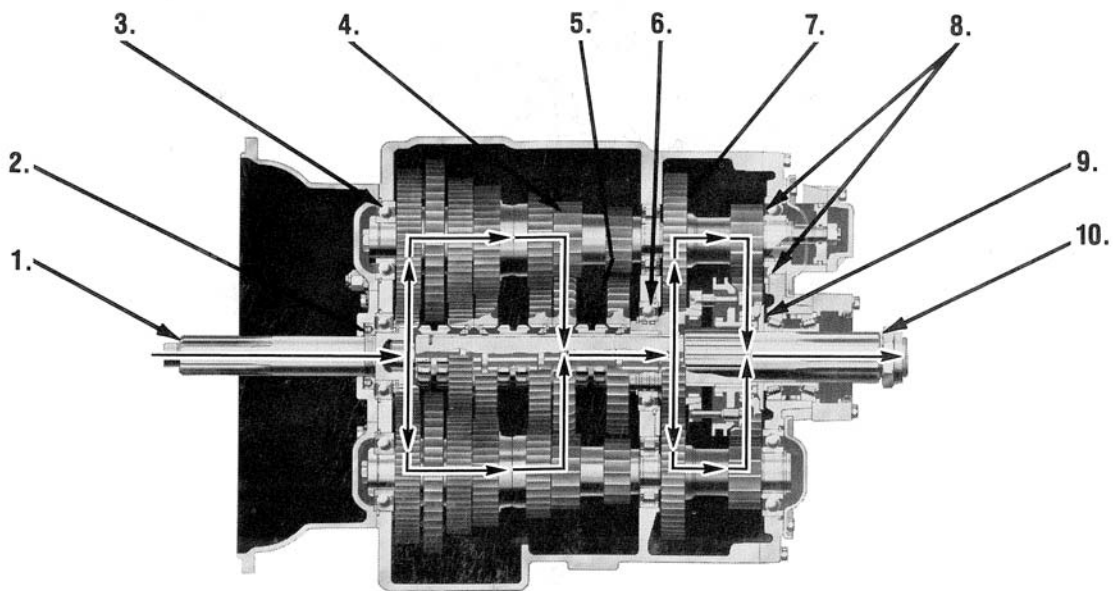

Auxiliary Section Power Flow - HI RANGE (All Models)

- The auxiliary drive gear transfers torque directly to the range mainshaft or output shaft through "engaged" sliding clutch. (7)
- Torque is delivered through the range mainshaft and/or output shaft to driveline as HI RANGE 6th. (8)

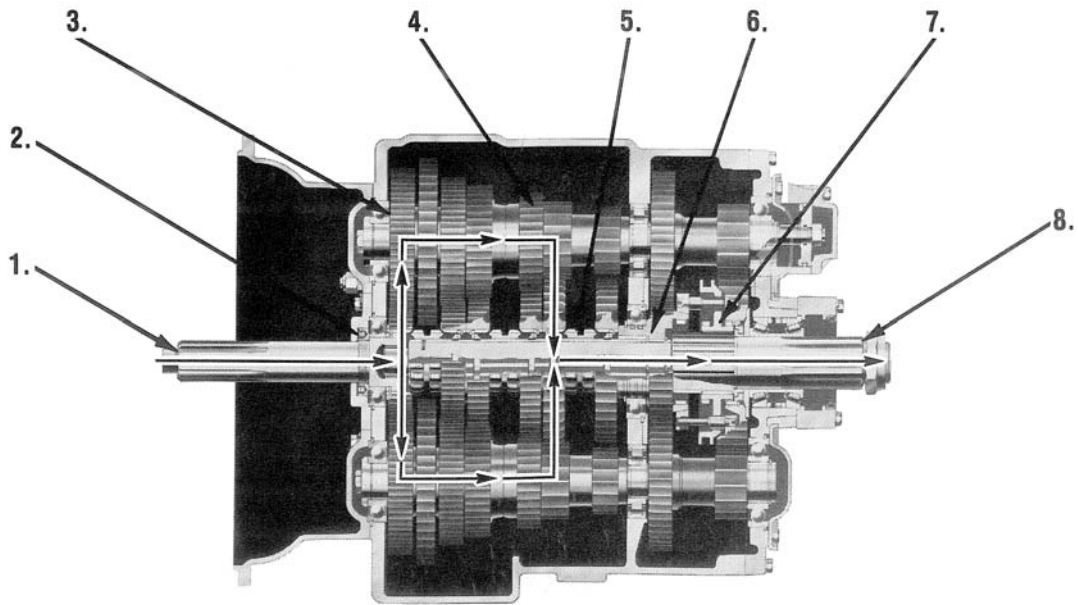

Power Flow

Timing

Timing Procedures

Special Instructions

It is essential that both countershaft assemblies of the front and auxiliary sections are "timed." This assures proper tooth contact is made between mainshaft gears seeking to center on the mainshaft during torque transfer and mating countershaft gears that distribute the load evenly. If not properly timed, serious damage to the transmission is likely to result from unequal tooth contact causing the mainshaft gears to climb out of equilibrium.

Timing is a simple procedure of marking the appropriate teeth of a gear set prior to installation and placing them in proper mesh while in the transmission. In the front section, it is necessary to time only the drive gear set. And depending on the model, only the LO range, deep reduction, or splitter gear set is timed in the auxiliary section.

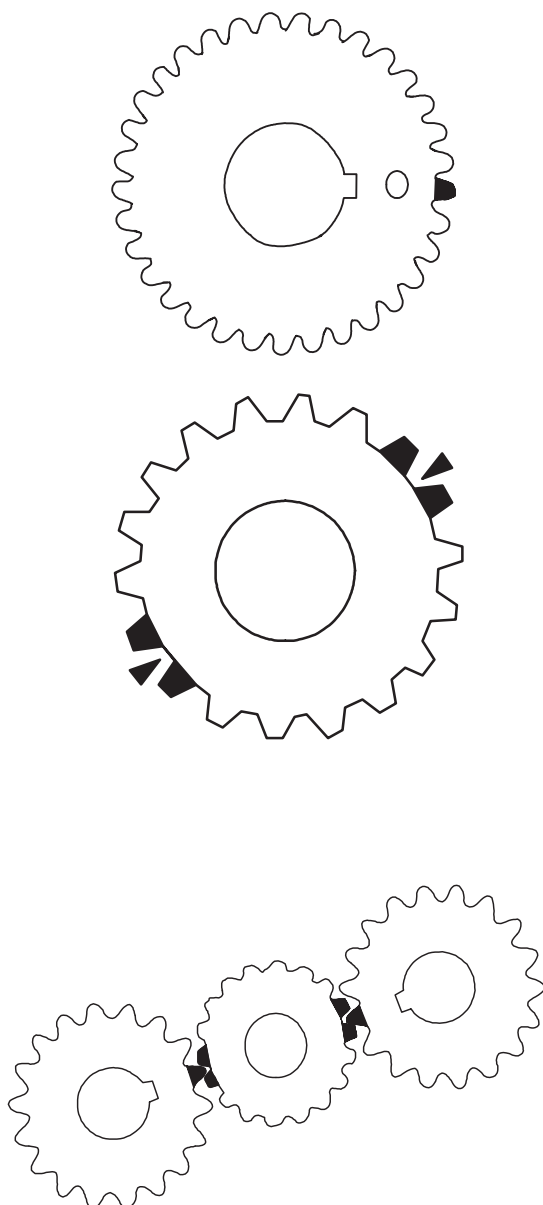

Procedure - Front Section

1. **Marking countershaft drive gear teeth:** Prior to placing each countershaft assembly into the case, clearly mark the tooth located directly over the drive gear keyway as shown. This tooth is stamped with an "O" to aid identification.

2. **Marking main drive gear teeth:** Mark any two adjacent teeth on the main drive gear.

Mark the two adjacent teeth located directly opposite the first set marked on the main drive gear. As shown to the left, there should be an equal number of unmarked gear teeth on each side between the marked sets.

3. **Meshing marked countershaft drive gear teeth with marked main drive gear teeth:** After placing the mainshaft assembly into the case, the countershaft bearings are installed to complete installation of the countershaft assemblies.

When installing the bearings on the left countershaft, mesh the countershaft drive gear marked tooth with either set of main drive gear two marked teeth.

Repeat the procedure when installing the bearings on the right countershaft, make use of the remaining set of main drive gear two marked teeth to time assembly.

Procedure - Auxiliary Section

4. **Marking the helical auxiliary countershafts:** Mark any two teeth on the LO range gear. Then mark two teeth located directly opposite the first marked.

Prior to placing each auxiliary countershaft assembly into housing, mark the tooth on each auxiliary countershaft assembly LO range gear stamped with the two "O"s. Repeat the procedure on each auxiliary countershaft reduction gear.

Follow the assembly procedures in the "How to Install the Auxiliary Section With Tapered Bearings" on page 165.

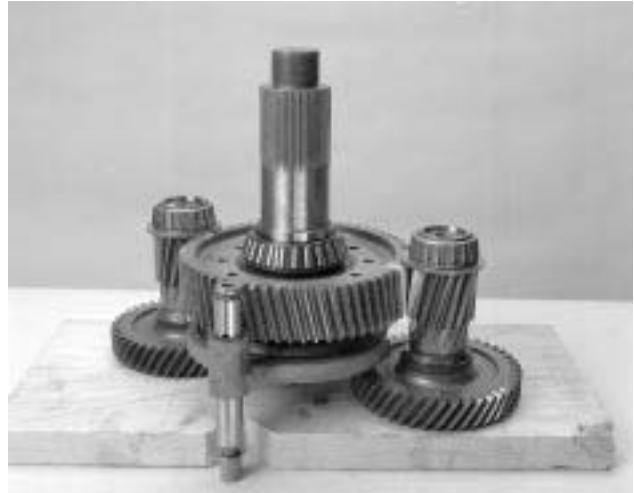

Air System

How to Remove Compression Type Fittings

Special Instructions

⚠ WARNING

A sudden release of air pressure can cause personal injury or damage to equipment. To prevent injury or equipment damage, exhaust the vehicle air tanks.

⚠ CAUTION

Small air lines are available in 1/8" or 5/32" sizes. Make sure 1/8" air lines are used with 1/8" fittings and 5/32" air lines are used with 5/32" fittings. Mixing sizes can cause air leaks or damage to fittings.

Before removing the air lines and hoses, label or record their location.

Special Tools

Typical service tools

Procedure -

1. Exhaust the vehicle air tanks before continuing.
2. Loosen the nut on the fitting, and slide it back out of the way.
3. Pull the air line and attached collet from the fitting.
4. Inspect the fitting, air line, collet, and nut for damage or wear. Replace as necessary.

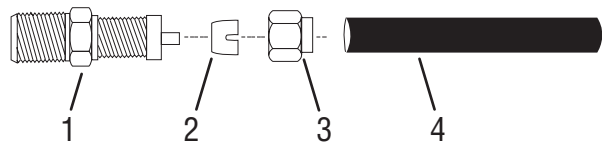

1. Connector
2. Collet
3. Nut
4. Air Line

How to Install Compression Type Fittings

Special Instructions



A sudden release of air pressure can cause personal injury or damage to equipment. To prevent injury or equipment damage, exhaust the vehicle air tanks.



Small air lines are available in 1/8" or 5/32" sizes. Make sure 1/8" air lines are used with 1/8" fittings and 5/32" air lines are used with 5/32" fittings. Mixing sizes can cause air leaks or damage to fittings.

Special Tools

Typical service tools

Procedure -

1. Check the threads of the fitting for thread sealant. If no sealant is present, apply Eaton® Fuller® thread sealant #71205 or equivalent.
2. Install the fitting.

Note: Do not overtighten the nut. Overtightening can compress the collet too much and cause an air line restriction.

3. Install the air line, collet, and nut. If installing a new fitting, place the collet in the fitting and loosely install the nut. (Do not tighten the nut yet.) Insert the air line through the nut and into the collet. Tighten the nut as usual.

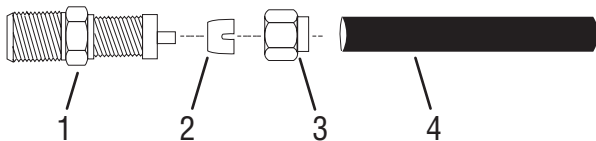

1. Connector
2. Collet
3. Nut
4. Air Line

4. Enable the vehicle air system. Allow the air tanks to pressurize, and check for leaks. Repair as necessary.

Air System

How to Remove Push-To-Connect Type Fittings

Special Instructions

⚠ WARNING

A sudden release of air pressure can cause personal injury or damage to equipment. To prevent injury or equipment damage, exhaust the vehicle air tanks.

⚠ CAUTION

Make sure only 5/32" air lines are used with push-to-connect fittings. Using sizes other than 5/32" can cause air leaks or damage to fittings.

Before removing the air lines and hose, label or record their location.

Special Tools

See "Tool Information".

For 'push-to-connect' fittings, the Eaton service tool kit K-2394 is recommended.

The kit contains the release tool and the tubing cutter.

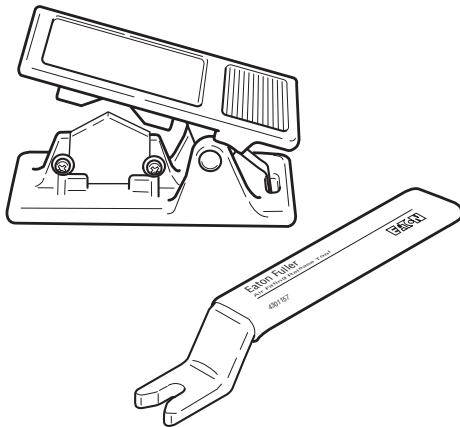

Procedure -

1. Exhaust the vehicle air tanks before continuing.
2. Use the air line release tool from kit K-2394 to press the release sleeve down while pulling the air line from the fitting.
3. Inspect the fitting for damage or wear. Remove and replace as necessary.

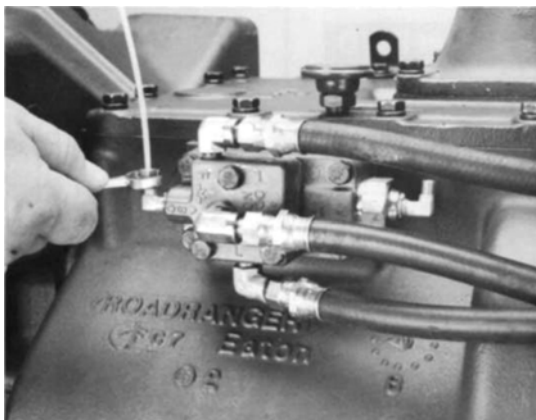

How to Install Push-To-Connect Type Fittings

Special Instructions

⚠ WARNING

A sudden release of air pressure can cause personal injury or damage to equipment. To prevent injury or equipment damage, exhaust the vehicle air tanks.

⚠ CAUTION

Make sure only 5/32" air lines are used with push-to-connect fittings. Using sizes other than 5/32" can cause air leaks or damage to fittings.

Special Tools

See "Tool Information"

For 'push-to-connect' fittings, we recommend Eaton service tool kit K-2394. The kit contains the release tool and the tubing cutter.

Procedure -

1. Check the threads of the fitting for thread sealant. If no sealant is present, apply Eaton® Fuller® thread sealant #71205 or equivalent.
2. Install the fitting.
3. Inspect the air line for burrs or deformed areas. Trim the air line if necessary using a sharp razor blade or the air line cutting tool from kit K-2394. The cut must be smooth and square. If the tubing end is deformed or burred, the internal O-ring in the fitting will be damaged when the air line is inserted.
4. Push the air line into the fitting. It should insert approximately 3/4". If it does not insert far enough or is difficult to insert, the fitting may be damaged and should be replaced. After inserting, give the air line a slight tug to make sure the line stays in place. If line does not stay in place, replace the fitting.
5. Enable the vehicle air system. Allow the air tanks to pressurize, and check for leaks.



Air System

How to Remove Rubber 1/4" Air Hoses

Special Instructions

For the 1/4" I.D. air hoses, install the fixed nut end first.

Special Tools

Typical service tools



Procedure -

1. Remove all air line brackets and ties.
2. Remove swivel end.
3. Remove fixed end.

How to Install Rubber 1/4" Air Hoses

Special Instructions

For the 1/4" I.D. air hoses, install the fixed nut end first.

Special Tools

Typical service tools

Procedure -

1. If necessary, apply Eaton Fuller thread sealant # 71205 or equivalent to threads.
2. Install and tighten fixed end first, then install and tighten swivel end.
3. Replace all air line brackets and ties.



Air System

How to Install the Air Filter/Regulator

Special Instructions

The air filter/regulator has two (2) O-rings located between the filter/regulator and the range cylinder cover.

Special Tools

Typical service tools

Procedure -

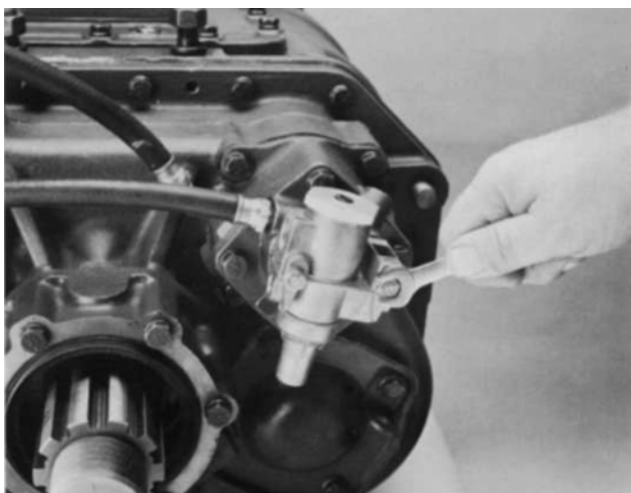

1. Position the air filter/regulator.
2. Apply Eaton/Fuller Sealant #71205 or equivalent to the two (2) retaining cap screws.
3. Install the two (2) retaining cap screws, tighten to 8-12 lbs. ft. of torque.

How to Remove the Air Filter/Regulator

Special Instructions

The air filter/regulator has two (2) O-rings located between the filter/regulator and the auxiliary section.

Special Tools

Typical service tools

Procedure -

1. Remove the air lines from the air filter regulator.
2. From the air filter/regulator, remove the two (2) capscrews.

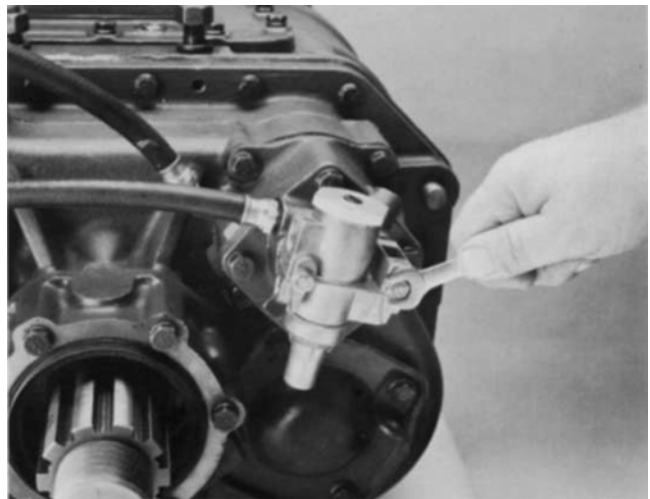

Air System

How to Remove a Roadranger Valve

Special Instructions

 **WARNING**

A sudden release of air pressure can injure you or damage equipment. To prevent injury or equipment damage, the vehicle air tanks must be exhausted.

Special Tools

Typical service tools



Procedure -

1. From the Roadranger valve cover, remove the two (2) mounting screws.
2. Slide the Roadranger valve cover down.
3. From the air fittings, disconnect the air lines.
4. From the Roadranger base, loosen the jam nut. Rotate the Roadranger valve until the valve is removed.
5. Inspect the parts: nut, valve cover, air lines, sheathing, and O-rings from the lever shaft.
6. In the Roadranger valve, inspect the air fittings, and remove if damaged.

How to Install a Roadranger Valve

Special Instructions

To position the Roadranger valve, the range lever must be to the front or the splitter button to the left when facing forward.

Special Tools

Typical service tools

Procedure -

1. Make sure the nut, valve cover, air lines, sheathing, and O-rings are in position on the lever shaft.
2. If previously removed, replace the air fittings and torque to 84-120 lbs. in.
3. Place the Roadranger valve on the lever shaft and rotate so the range selector faces the vehicle front.
4. From the Roadranger valve bottom, tighten the jam nut to 35-45 lbs. ft. of torque.
5. Connect the air lines to the air fittings.
6. Slide the cover into position on the Roadranger valve.
7. Install the Roadranger valve cover mounting screws.

Note: Make sure the air lines are seated fully.



Air System

How to Remove a Slave Valve

Special Instructions

⚠ WARNING

A sudden release of air pressure can injure you or damage equipment. To prevent injury or equipment damage, the vehicle air tanks must be exhausted.

Special Tools

Typical service tools



Procedure -

1. Record or mark air line locations.
2. Remove all air lines.
Note: Remove three 1/4" ID air hoses at swivel fitting at range cylinder location. Remove air line bracket at rear of transmission. Remove slave valve with air hoses still attached.
3. Remove the retaining cap screws around valve perimeter.
4. Remove slave valve and gasket.
5. From the transmission case, remove the sleeve, spring, and plunger pin.
6. Inspect the air fittings, replace if damaged.

How to Install a Slave Valve

Special Instructions

None

Special Tools

Typical service tools

Procedure -

1. Clean gasket surface and install air fittings.
2. Lightly lubricate and install plunger pin, spring, and sleeve into case.
3. Install any necessary air hoses at this time.
4. Install new gasket.
5. Apply Eaton/Fuller Sealant #71205 or equivalent to the retaining capscrews.
6. Install the retaining capscrews. Tighten to 8-12 lbs. ft. of torque.

Note: Make sure the retaining capscrews are properly torqued.

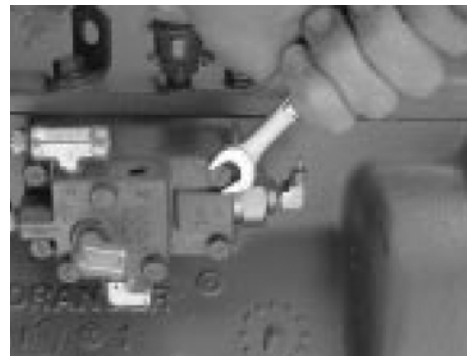

In-Vehicle Service Procedure

How to Remove the Gear Shift Lever/Remote Shift Control

Special Instructions

The air lines must be disconnected from the transmission or from the Roadranger valve.

Different detent springs are available to increase or decrease shifting effort. Note and record specific locations for specific springs. In some cases, a stiffer spring is installed in the top rail position.

Remote control housings are removed the same way as gear shift levers.

Special Tools

Typical service tools

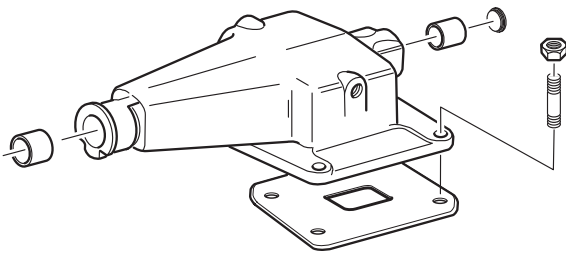
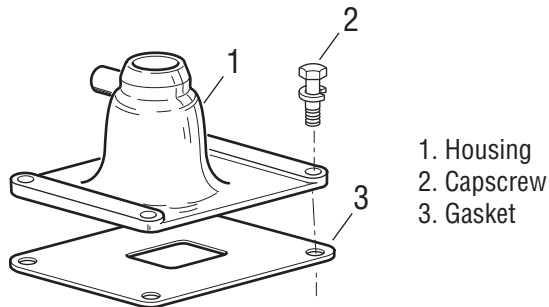

Procedure -

1. From the gear shift lever base/shift control housing, remove the four (4) retaining capscrews.

2. To break the gasket seal, lightly jar the gear shift/shift control housing.

3. Remove the gear shift lever housing.

CAUTION

Make sure the detent springs do not fall into the transmission.

4. Remove detent springs as needed.
5. Remove the gasket and clean the area the replacement gasket will contact.

How to Install the Gear Shift Lever/Remote Shift Control

Special Instructions

Remote control housings are installed the same way as gear shift levers.

For standard and forward shift bar housings, make sure the detent springs and balls are in the shift bar housing top bores.

Make sure the shift block and yoke notches are aligned in the neutral position.

Special Tools

Typical service tools

Procedure -

1. Thoroughly clean mounting surface.
2. Position a new gear shift lever/shift control housing gasket on the gear shift lever mounting surface.
3. Install the detent springs.



4. Install the shift lever/shift control housing. Make sure the tip (finger) of the gear shift lever fits into the slots in the shift block.

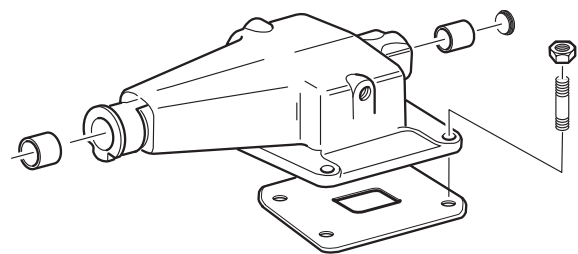

5. Apply Eaton/Fuller Sealant #71205 or equivalent to the retaining capscrews.
6. Install the retaining capscrews, tighten to 35-45 lbs. ft. of torque.

Note: Make sure the capscrews are properly torqued.

Note: Make sure you can shift the transmission.

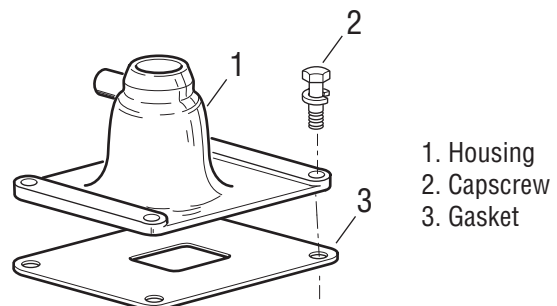

In-Vehicle Service Procedure

How to Adjust the Remote Shift Control (LRC Type)

Special Instructions

The following is a typical adjustment procedure for an LRC type slave control. It is recommended that the OEM Chassis Service Manual be consulted first.

Special Tools

Typical service tools

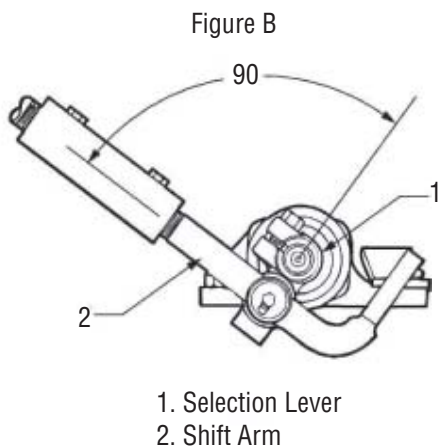
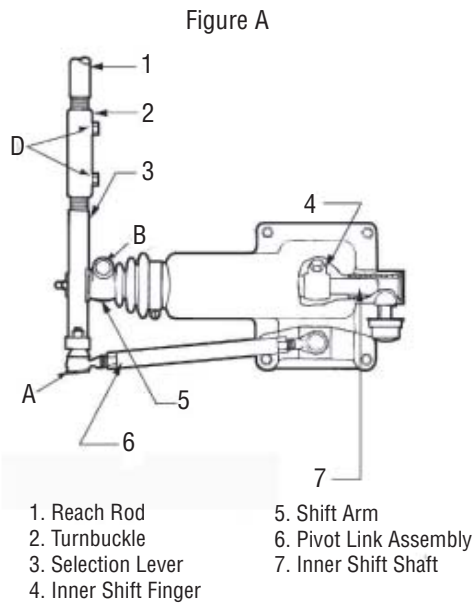

Procedure -

1. Move the gear shift lever forward or backward to the neutral position.
2. Move the gear shift lever sideways, toward reverse, until you feel resistance from the reverse plunger spring. DO NOT shift to reverse. The shift finger must remain in this position while you are making all the adjustments.
3. Remove the cotter pin, castle nut and ball joint A (see figure A) from the selection lever. Do not remove the ball joint from the pivot link.
4. Loosen the capscrew B (see figure A) and remove the shift arm from the inner shift shaft. Do not disconnect the selection lever from the shift arm.
5. Turn the shift arm until it is at a right angle (90°) to the selection lever as viewed from the side (see figure B).

Note: Ideally, the shift arm should be adjusted 90° to the selection lever as described, but in some chassis configurations it may be necessary to index the shift arm in the vertical position. Indexing the shift lever is done to prevent shift lever jump out. This type of adjustment will cause an unequal amount of gear shift lever travel between neutral and a forward lever position as compared to neutral and a rearward lever position.

6. Install the shift arm on the splines of the inner shift shaft. You may have to move the shift arm 4° or 5° to align the splines of the two parts. Disregard any movement of the gear shift lever at this point. The gear shift lever will be

adjusted later.

7. Tighten the capscrew B (see figure A) on the shift arm.
8. Connect the pivot link assembly ball joint to the selection lever. Secure it with the castle nut and cotter pin.
9. Loosen the jam nuts C (see figure C) on the pivot link.
10. Check to be sure the inner shift finger is still in place.
11. Rotate the pivot link until the curved end of the selection lever is parallel with the shift arm as viewed from the rear (see figure C).
12. Tighten the pivot link jam nuts C (see figure C).
13. Loosen both capscrews on the turnbuckle D (see figure A).
14. Check to be sure inner shift finger is still in place.
15. Rotate the turnbuckle to obtain the proper forward-backward neutral position of the gear shift lever in the cab.
16. Tighten one turnbuckle D capscrew (see figure A).
17. Move the gear shift lever to the desired position.
18. Turn the second turnbuckle D capscrew.
19. Check for linkage obstructions in all gear positions.

Figure C

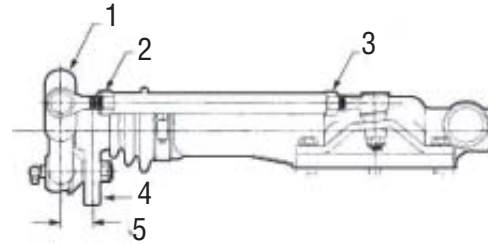

1. Selection Lever
2. L.H. Thread
3. R.H. Thread
4. Shift Arm
5. Parallel

In-Vehicle Service Procedure

Neutral Switch Operation and Testing

Special Instructions

The neutral switch is a normally closed switch. An electrical current flows through it when the transmission shifter is in the neutral position. When the transmission shifter is in gear, the switch is open and no current flows through it. Likewise, the switch is open when the ball is depressed. The switch is actuated by the air valve shaft.

Special Tools

Typical service tools

Volt/Ohm meter

Procedure -

1. Disconnect the wiring from the switch.
2. Connect an ohm meter to check for continuity or a small reading.
3. Place the transmission shift lever in the neutral position. The ohm meter should register continuity or a small reading. If it does, go to the next step. If it does not, remove the switch and replace it.
4. Shift the transmission into all gear positions. The ohm meter should read open or infinity. If it does not, remove the switch. Then, depress the switch ball and check for continuity. The ohm meter should read open or infinity when the ball is depressed.
5. Look into the neutral switch hole and verify that the air valve shaft moves as the transmission is shifted from neutral into gear.
 - If it does, replace the switch.
 - If not, remove the shift bar housing and check the air valve and shift rails for excessive wear. Also, check the slave valve plunger and spring for free movement.

How to Remove the Neutral Switch

Special Instructions

None

Special Tools

Typical service tools

Procedure -

1. Remove 2 screws retaining wire terminals.
2. Remove the switch using a 7/8" deep well socket or box end wrench.

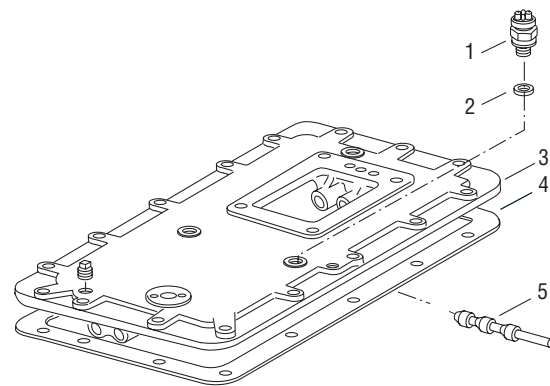

1. Neutral Light Switch
2. Gasket
3. Shift Bar Housing
4. Gasket
5. Air Valve Shaft

In-Vehicle Service Procedure

How to Install the Neutral Switch

Special Instructions

None

Special Tools

Typical service tools

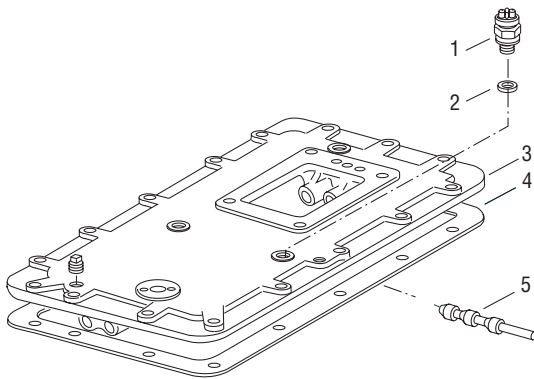

1. Neutral Light Switch
2. Gasket
3. Shift Bar Housing
4. Gasket
5. Air Valve Shaft

Procedure -

1. Install a new gasket.
2. Install the neutral switch. Tighten it to 15-20 lbs. ft. (20-27 N•m) of torque.
3. Connect the wiring to the switch.

Reverse Switch Operation and Testing

Special Instructions

The reverse switch is a normally open ball switch. When the transmission is shifted into reverse, a ramp on the reverse yoke bar contacts and raises a pin. The pin depresses the ball on the switch, which closes the switch contact, allowing current to flow through the switch and light up the vehicle's backup lights.

Special Tools

Typical service tools

Volt/Ohm meter

Procedure -

1. Disconnect the wiring from the switch.
2. Connect an ohm meter to check for continuity.
3. Place the transmission shift lever in any position except reverse. If the switch is working properly, the ohm meter should read open or infinity. If it is not, remove the switch and recheck it for continuity. Replace as necessary.
4. Place the transmission shift lever in the reverse position. If the switch is working properly, the ohm meter should register continuity, or a small reading. If it does not, remove the switch and recheck it for continuity. Replace it as necessary. Also, check for sticking or excessive wear of the reverse pin.

In-Vehicle Service Procedure

How to Remove the Reverse Switch

Special Instructions

None

Special Tools

Typical service tools

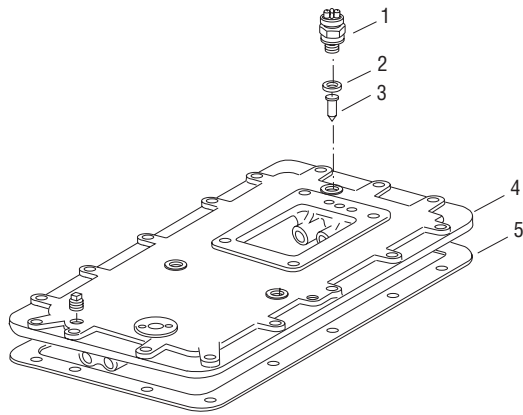

1. Reverse Light Switch
2. Gasket
3. Pin
4. Shift Bar Housing
5. Gasket

Procedure -

1. Remove 2 screws retaining wire terminals.
2. Remove the switch using a 7/8" deep well socket or box end wrench.

How to Install the Reverse Switch

Special Instructions

None

Special Tools

Typical service tools

Procedure -

1. Insert the reverse pin in the reverse switch bore.
2. Install new gasket on switch.
3. Install the reverse switch. Tighten it to 15-20 lbs. ft. (20-27 N•m) of torque.
4. Connect the wiring to the switch.

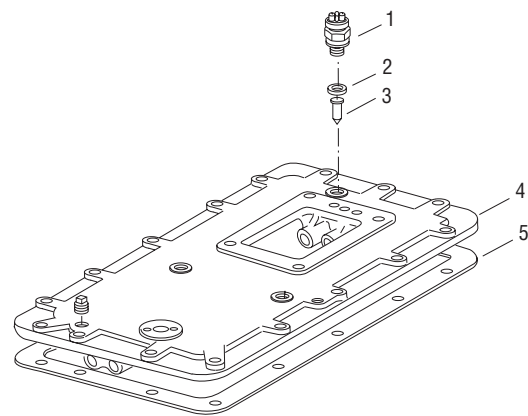

1. Reverse Light Switch
2. Gasket
3. Pin
4. Shift Bar Housing
5. Gasket

In-Vehicle Service Procedure

How to Remove the Output Yoke/Companion Flange and Nut

Special Instructions

You must remove the shift bar housing in order to lock the transmission.

For proper cleaning and maintenance, see TRSM0912 "Rear Seal Maintenance Guide".

After removal of the output yoke/companion flange, temporarily replace the output shaft nut to protect the output shaft threads during auxiliary section disassembly.

Special Tools

See Tool Information.

A large breaker bar or air impact wrench

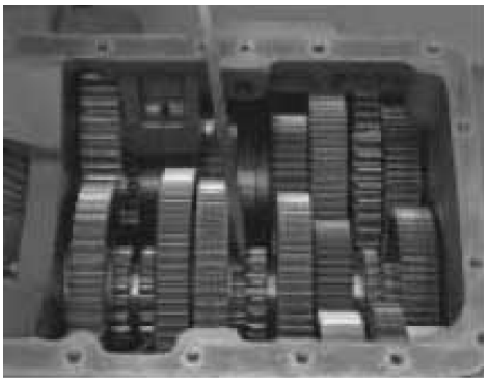

Procedure -

1. Engage two (2) mainshaft sliding clutches into two (2) mainshaft gears to lock the transmission or use a yoke holding tool if available.
2. Use a large breaker bar or air impact wrench to remove the output shaft nut.

In-Vehicle Service Procedure

3. Remove the output yoke. Use the output yoke puller (Tool ref. ID T1).



In-Vehicle Service Procedure

How to Install the Output Yoke/Companion Flange and Nut

Special Instructions

You must remove the shift bar housing in order to lock the transmission.

For proper cleaning and maintenance, see TCSM0912 Seal Maintenance Guide.

Special Tools

See Tool Information.

Torque wrench with 0-600 lbs. ft. capacity

Procedure -

1. Engage two (2) mainshaft sliding clutches into two (2) mainshaft gears to lock the transmission, or use a yoke holding tool if available.
2. Install the speedometer drive gear rotor or replacement spacer on the output shaft inside the rear bearing cover.
3. If the slinger on the yoke is damaged, replace using a Slinger/Seal kit.
4. Install the output yoke over the output shaft. The yoke should slide on and stop before contacting the speedometer rotor. As the output shaft nut is installed, the output yoke will contact the speedometer rotor.

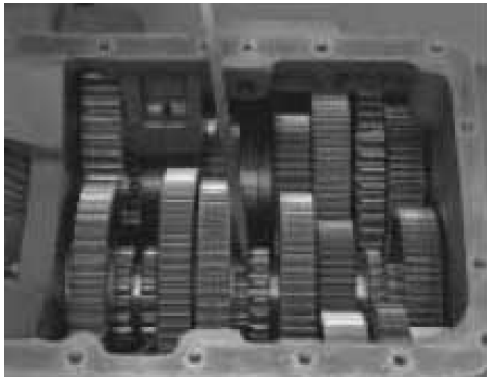

In-Vehicle Service Procedure

5. Install the output shaft nut, tighten to 450-500 lbs. ft. of torque.
6. Make sure the output shaft nut is properly torqued and unlock the transmission, or remove the yoke holding tool.



In-Vehicle Service Procedures

How to Remove the Output Yoke / Flange and Retaining Capscrews

Special Instructions

None

Special Tools

- Typical service tools

Procedure -

1. Remove drive shaft from transmission. Reference OEM removal guidelines.
2. Remove the end yoke retaining capscrews and washer from auxiliary mainshaft.
3. Remove the end yoke/flange.

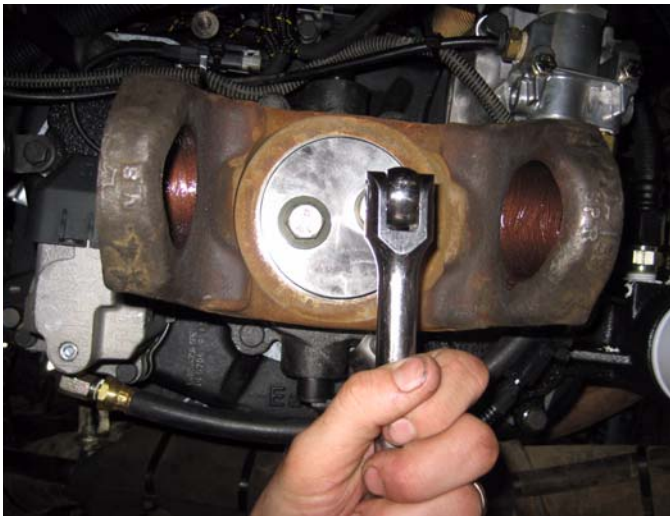

How to Install the Output Yoke / Flange and Retaining Capscrews

Special Instructions

For proper cleaning and maintenance, see TCSM0912 Seal Maintenance Guide.

Special Tools

- Typical service tools

Procedure -

1. Install end yoke, retaining washer, and capscrews. Apply Eaton/Fuller #71205 liquid thread sealant to capscrews and then snug each capscrew to 35 lbs. ft. [47 N·m.]
2. Fully tighten both retaining capscrews to specified torque rating 74-81 lbs. ft. [100-110 N·m.]

Note: This fastening design employs Spirallock™ threads. A conventional metric thread pitch tap cannot be used for thread restoration on this product.

WARNING

Use only Eaton/Fuller #71205 liquid thread sealant or liquid equivalent on the yoke retaining capscrews. Do not use any type of thread locking tape on the end yoke retaining capscrews. This may cause the capscrews threads to strip and cause the end yoke to loosen.

3. Reinstall driveshaft per OEM guidelines.



In-Vehicle Service Procedure

How to Remove the Auxiliary Section with Tapered Bearings

Special Instructions

There can be different capscrew lengths, note their location.

Auxiliary sections can be removed either with the transmission in the horizontal position or the vertical position.

Auxiliary countershaft retaining straps may be installed to hold the countershafts in place. You can make retaining straps from 3" x 1" bar stock. Auxiliary can be removed without straps, use caution.

Special Tools

See Tool Information.

Item T2: Auxiliary section hanger bracket for horizontal removal

A steel bar longer than the width of the output yoke for vertical removal

A hoist with a lifting chain

Auxiliary countershaft retaining straps



Procedure -

1. To remove the auxiliary section in the horizontal position:

Remove the four (4) capscrews and the auxiliary countershaft rear bearing cover, gasket, and rear bearing shim.

In-Vehicle Service Procedure

2. Install the auxiliary countershaft retaining straps with 2 - 3/8" NC x 1" and 1 - 3/8" NC x 1-1/2" clean capscrews.

Note: Do not use an air gun. Tighten by hand until the capscrews are snug.

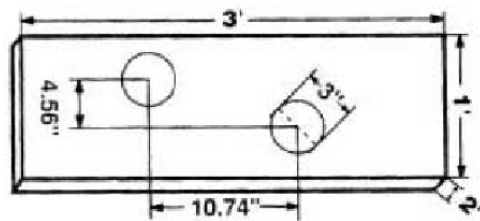
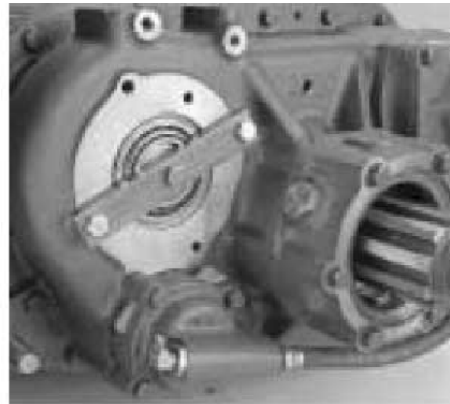

3. From the auxiliary section housing, remove the retaining capscrews that attach the front section to the auxiliary section.
4. Insert the two (2) longest capscrews in the housing flange tapped holes. Tighten evenly to move the auxiliary section away from the front box. Go far enough to break the gasket seal.
5. Remove the capscrews from the tapped holes.
6. Attach an auxiliary section hanger bracket to the auxiliary section top.
7. Attach a lifting chain to the auxiliary section hanger bracket.
8. Move assembly to the rear until auxiliary section is free.
9. Remove the gasket and clean all mounting surfaces of gasket material.



In-Vehicle Service Procedure

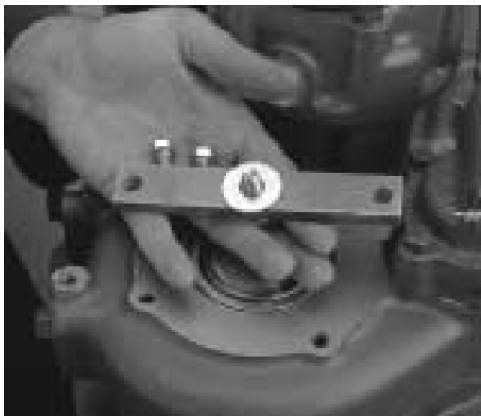

Procedure -

1. To remove the auxiliary section in the vertical position:

With blocks under the clutch housing to prevent input shaft damage, place transmission in the vertical position, clutch housing down.

2. Remove the four (4) capscrews and the auxiliary countershaft rear bearing cover, gasket, and rear bearing shim. Clean the gasket surface area.

3. Install the auxiliary countershaft retaining straps with 2 - 3/8" NC x 1" and 1 - 3/8" NC x 2-1/2" clean capscrews.

Note: Do not use an air gun. Tighten by hand until the capscrews are snug.

4. From the auxiliary section housing, remove the retaining capscrews that attach the front box to the auxiliary section.

5. Install a steel bar through the yoke.

6. Attach a lifting chain to the steel bar.

7. Lift assembly from the front section.

How to Install the Auxiliary Section in Chassis

Special Instructions

None

Special Tools

See Tool Information.

Item T3: Countershaft support tools

Item T14: Auxiliary section removal adapter plate

A hoist with lifting chain

Procedure -

1. Install the countershaft support tools on the auxiliary section countershafts to center and hold the countershafts in position. Install a 3/8"-16 X 2-1/2" long capscrew into countershaft center.
2. If removed, slide the output yoke over the output shaft. Lightly oil the threads and install the output nut on the output shaft. Torque the nut to 450-500 lbs. ft. (610-677 N•m).

Note: To prevent the output shaft from rotating while installing the nut, place a clean shop rag in the gear mesh.

Note: Due to chassis interference, it may not be possible to install the yoke at this step. However, the output shaft must be drawn fully into position to prevent it from sagging when the auxiliary section is installed in the chassis. If the chassis causes interference, the yoke can be temporarily installed to draw up the output shaft and then removed before the auxiliary section is installed.

3. Use crocus cloth or a wire wheel to clean rust and paint from the dowel pins before installing them.



CAUTION: If the dowel pins are not installed in the main case to the proper depth, the auxiliary section will not properly align with the main case and bearing or synchronizer failure may occur.



In-Vehicle Service Procedure

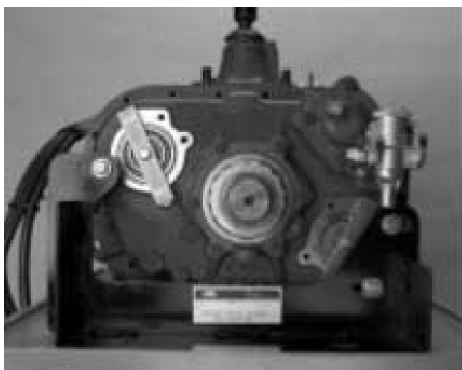
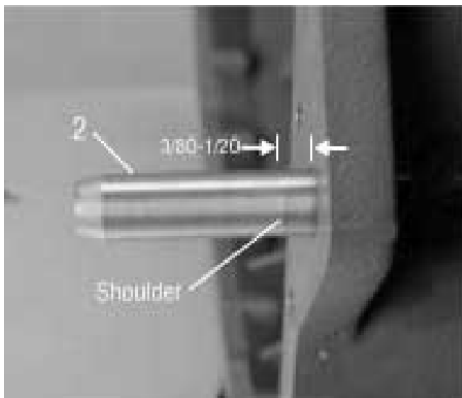

4. Install the dowel pins into the main case so that 3/8"-1/2" of the shoulder is exposed or pin is flush with front of case ear.
5. Clean all rust and paint from the dowel pin holes in the auxiliary section housing, and lightly grease the dowel pins on the main case and the dowel pin holes on the auxiliary section housing.
6. Make sure the auxiliary section is in low range. If not, blow shop air (max 100 PSI) into the low range supply port to shift the range synchronizer to low. If necessary, make sure the deep reduction clutch is engaged into gear.
7. Position the gasket onto the main case mounting surface.
8. Mount the auxiliary section on the lifting device or jack.
9. Tighten the center capscrew on the countershaft support tools to draw the countershafts into a level position. Do not overtighten the capscrews. The output yoke and shaft must be able to rotate.
10. Position the auxiliary section in line with the main case, and slide the housing onto the dowel pins. Mesh the countershafts with the auxiliary drive gear. Rotate the output yoke and shaft slightly to help the gears mesh and slide the auxiliary section forward until it is flush with the main section.



CAUTION: The auxiliary section should slide into place fairly easily. DO NOT force it on or pull it into place with the capscrews. Excessive force may damage the transmission. If excessive force is necessary, the gearing is likely out of time.

11. If the auxiliary section does not install fully, slide it back and check the following:
 - a. The output yoke and nut should be installed to pull back and center the auxiliary mainshaft assembly.
 - b. The countershaft support tool center capscrew should be snug to level the countershafts.
 - c. The dowel pins and auxiliary housing mating holes should be clean and well oiled.
 - d. The internal gearing on the auxiliary section must have been properly timed during reassembly.
12. Apply Eaton® Fuller® thread sealant #71205 or equivalent to the all the retaining capscrew threads. Install the capscrews to secure the auxiliary section to the main case. Torque the capscrews to 40-45 lbs. ft. (54-61 N•m).

13. If the countershaft, countershaft bearings, or auxiliary housing have been replaced, or if the countershafts, bearings, or shims were not marked and reassembled in the same location, the bearing endplay must be checked and set by shimming. Shim the countershaft bearings using "Shim Procedure Without a Shim Tool for Tapered Bearings" on page 171.
14. If shimming is not required, remove the support tools, and install the proper shim, gasket, and countershaft bearing cover. Secure the bearing covers with the capscrews. Install sealer. Tighten the capscrews to 40-45 lbs. ft. (54-61 N•m).
15. Connect all removed air hoses and lines. Use Eaton® Fuller® thread sealant #71205 or equivalent as necessary.
16. Connect the driveshaft and U-joint, and refill the transmission with the recommended lubricant. For lubrication instructions refer to "Lubrication."

Bench Service Procedure

How to Disassemble the Gear Shift Lever

Special Instructions

If total disassembly is needed, the Roadranger valve, must be removed first.

Release the spring one coil at a time.

Special Tools

Vise with brass jaws or wood blocks

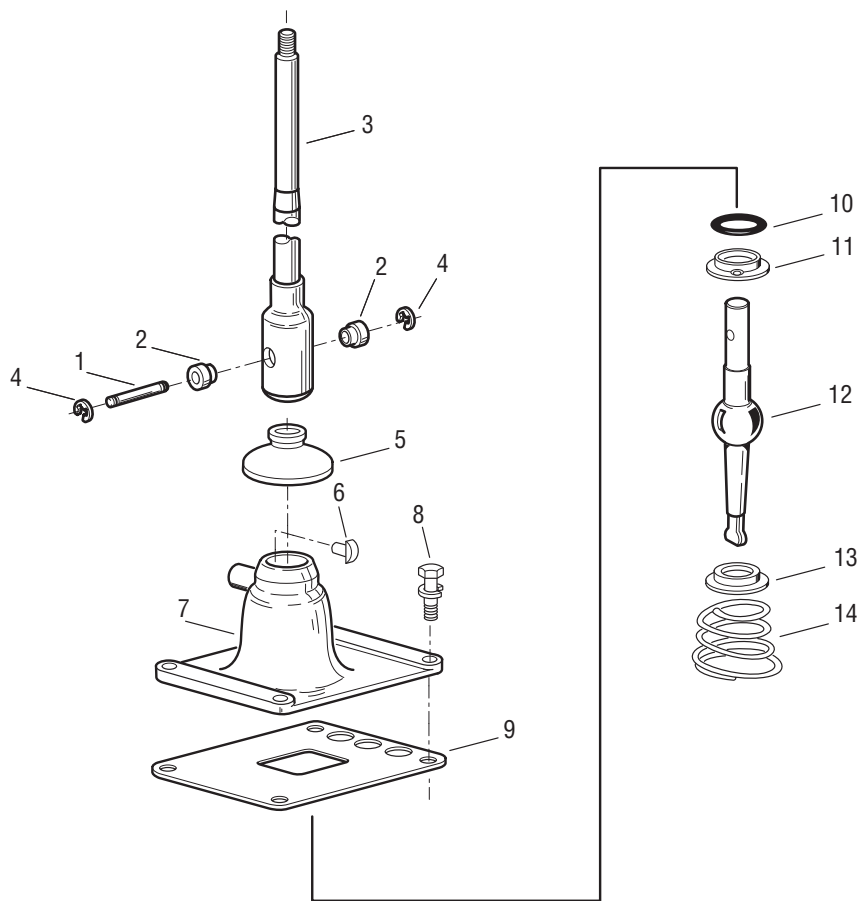

1. Pin

2. Bushing

3. Upper Lever

4. Snap Ring

5. Rubber Boot

6. Spade Pin

7. Housing

8. Capscrew

9. Gasket

10. O-ring

11. Washer

12. Lower Lever

13. Stepped Washer

14. Tension Spring

Procedure -

1. On a non-isolated shift lever, remove the Roadranger valve using the “How to Remove a Roadranger Valve” on page 37. If the shift lever is equipped with a lever isolator, remove the snap ring, bushing, and cross pin to disconnect and remove the upper lever.
2. Slide the rubber boot up and off the shift lever shaft.
3. With housing bottom facing up, secure the assembly in a vise.
4. Use large screwdriver to twist between the spring and housing, forcing the spring from under the housing lugs one coil at a time.
5. From inside the housing tower, remove the tension spring, washer, and gear shift lever.
6. In models so equipped, from the housing bore, remove the nut and washer.
7. From the housing tower spade pin bore, remove and inspect the spade pin, discard if damaged.
8. From the housing tower inside groove, inspect the O-ring, discard if damaged.

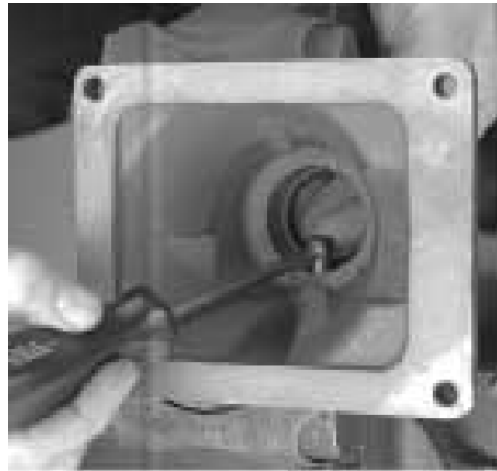

Bench Service Procedure

How to Assemble the Gear Shift Lever

Special Instructions

Inspect tension spring and washer for wear.

Apply Eaton rust preventative lubricant #71212 or equivalent to the shift lever pivot ball. A rust preventative lubricant film should cover all surfaces between and including the pivot ball.

Seat the tension spring one coil at a time.

Special Tools

Vise with brass jaws or wood blocks

Item T4: Tension Spring Driver

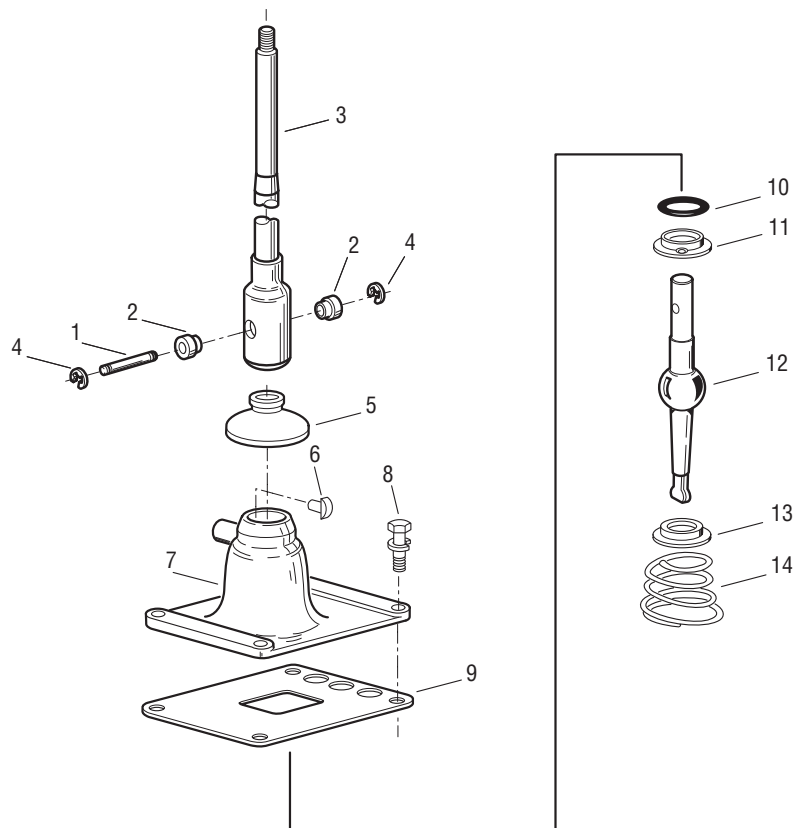

1. Pin

2. Bushing

3. Upper Lever

4. Snap Ring

5. Rubber Boot

6. Spade Pin

7. Housing

8. Capscrew

9. Gasket

10. O-ring

11. Washer

12. Lower Lever

13. Stepped Washer

14. Tension Spring

Bench Service Procedure

Procedure -

1. With housing bottom facing up, secure the assembly in a vise.
2. If the spade pin is damaged, replace and install the spade pin, in housing tower bore.
3. In models so equipped, install the nut and washer in the housing bore.
4. If the O-ring is damaged, replace; lubricate the O-ring with Eaton/Fuller lubricant #71206 or equivalent. Install the O-ring in the housing tower inside groove.
5. Align the lever ball slot with the spade pin and position the gear shift lever in the housing tower.
6. With dished-side up, install the washer over the ball.
7. Use a tension spring driver to install the tension spring under the housing lugs.
8. Remove the assembly from the vise.
9. Install a rubber boot over the gear shift lever and against the housing.

Note: Make sure the gear shift lever can move.

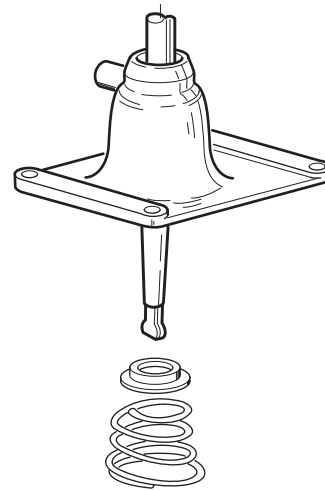
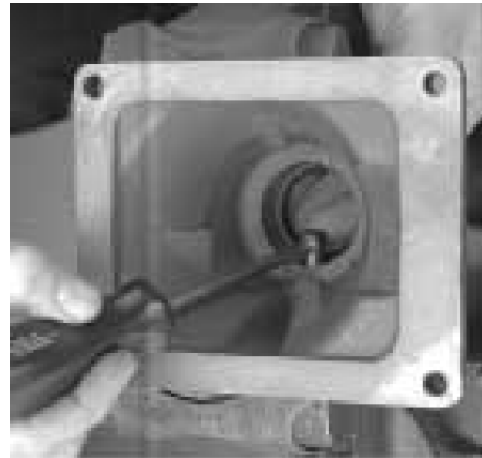

Bench Service Procedure

How to Remove the Shift Bar Housing

Special Instructions

Before removing the shift bar housing, the air lines must be disconnected.

For models equipped with an oil pump and/or cooler assemblies, make sure to disconnect the oil line connected to the shift bar housing.

There are three (3) sizes of capscrews. The 1 1/2" capscrews are used with the lifting eyes. The 1 1/4" are used on all other locations except the left front corner at the roll pin location. This capscrew is 1 3/4".

Be careful when removing the shift bar housing to prevent damaging the oil tube with the shift yokes.

Special Tools

Typical service tools

Procedure -

1. From the shift bar housing, remove the two retaining capscrews securing the oil cooler. Remove oil cooler and set aside.
2. Remove slave valve.



Bench Service Procedure

3. Remove interlock parts (pin, spring, and sleeve).



4. From the shift bar housing rim, remove the retaining cap-screws.



5. To break the gasket seal, jar the shift bar housing.

6. Remove the shift bar housing.



7. Inspect the roll pin, replace if damaged.

8. Remove the gasket and clean all mounting surfaces of gasket material.

9. If the three (3) sets of tension springs and balls from the housing top bores are loose, tilt the assembly and remove them.



Bench Service Procedure

How to Install the Shift Bar Housing

Special Instructions

There are three (3) sizes of capscrews. The 1-1/2" capscrews are used with the lifting eyes. The 1-1/4" are used on all other locations except the left front corner at the roll pin location. This capscrew is 1-3/4".

Be careful when removing the shift bar housing to prevent damaging the oil tube with the shift yokes.

The slave valve and interlock parts must be removed prior to installing the shift bar housing.

Special Tools

Typical service tools



Procedure -

1. Place the shift bar housing and shift blocks in the neutral position
2. Place the mainshaft sliding clutches in the neutral position.
3. Position a new shift bar housing gasket on the shift bar housing mounting surface.

Note: The slave valve and interlock assembly must remain off, until the shift bar housing is installed, to avoid damaging the interlock pin.

4. As you install the shift bar housing make sure the yokes fit into the corresponding sliding clutch slots and the housing aligns with the roll pin.
5. Apply Eaton/Fuller Sealant #71205 or equivalent to the retaining capscrews.

Bench Service Procedure

6. Install interlock parts (pin, spring and sleeve).



7. Install slave valve and tighten to specifications.



Bench Service Procedure

How to Disassemble the Shift Bar Housing

Special Instructions

To aid in assembly, mark the location and orientation of all shift yokes and blocks.

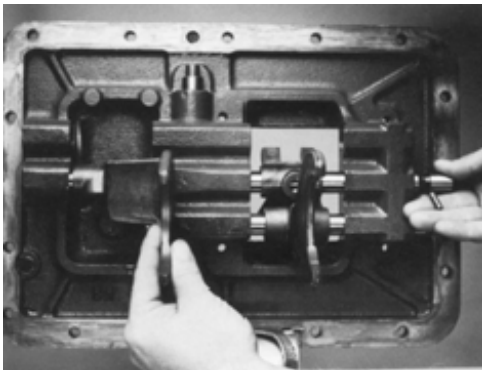
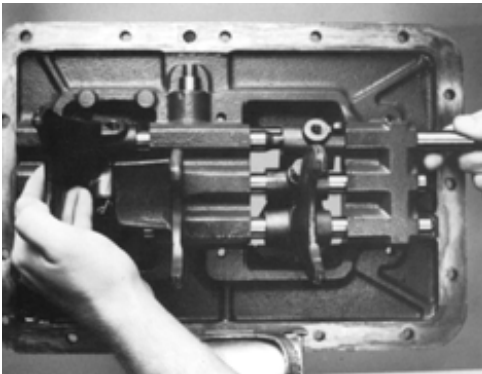
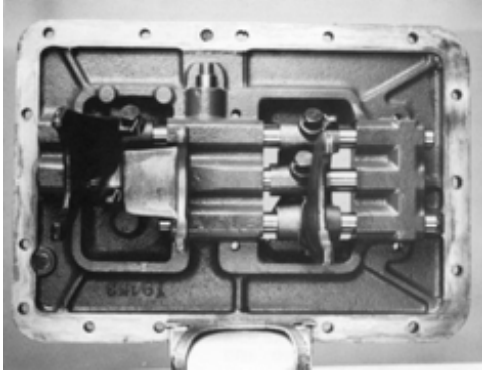

Procedure -

1. If installed, remove the oil trough capscrews and oil trough.

2. If present, cut and remove the lockwire on the yoke lock screws. Remove the yoke lock screws. Slide the yoke bar from the bore.

Note: The remaining yoke bars must be in the neutral position so that yoke bars will slide out freely.

3. Remove all yoke lockscrews, yoke bars, yokes, and shift blocks.

Bench Service Procedure

4. Remove the two 3/4" interlock balls.

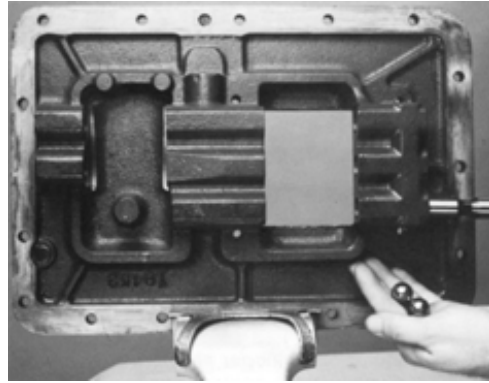

5. Remove the air valve shaft.

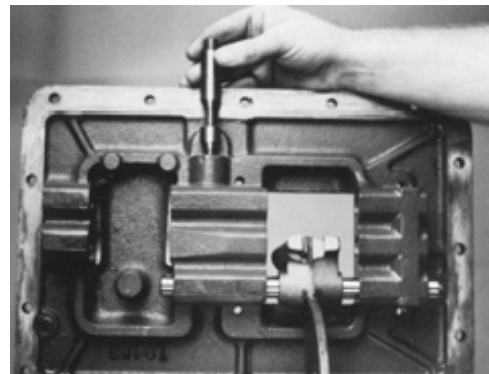

6. For the reverse yoke, unscrew the plug to remove the spring and plunger.



7. If equipped with a yoke activator (x-actuator configuration), remove the nut or snap ring (depending on version) and remove yoke activator.

Note: On version with snap ring, do not remove pivot pin if parts will not be replaced.

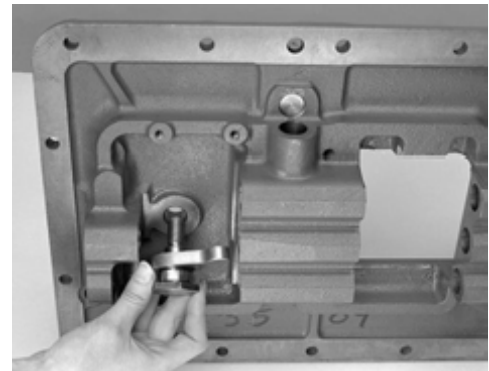

Bench Service Procedure

How to Assemble the Shift Bar Housing

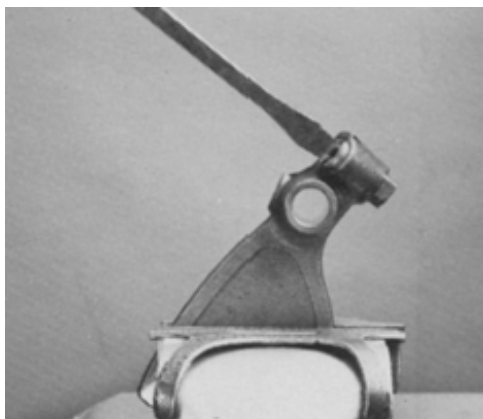

Procedure -

1. Install the plunger in the 1st & reverse shift yoke bore, plunger shank to the outside.
2. Install the spring into the bore over the plunger shank.
3. Install the plug and tighten to compress the spring.

Bench Service Procedure

4. After plug bottoms out, back the plug out 1 - 1-1/2 turns.



5. Complete the block assembly process by staking the plug through the small hole in block.



CAUTION: Overtorquing of lockscrew can result in distortion and binding of yoke bar. Make sure yoke bar has free movement. Lockwire lockscrew.

6. Install the reverse yoke bar, reverse yoke and direct/overdrive yoke (on x-actuator versions). The yoke bar neutral notches must be positioned in line with the detent ball bores. Start the lockscrews by hand to assure proper engagement of the cone into the yoke bar hole. Torque the lockscrews to 35-45 lbs. ft.

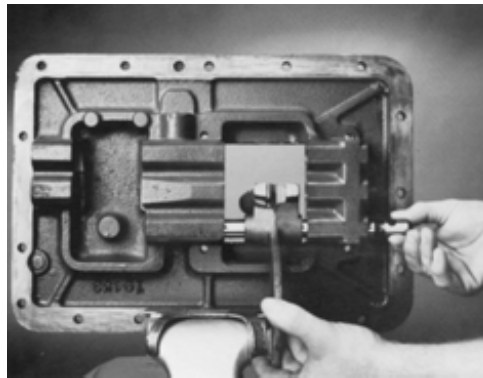

7. Install air valve shaft.

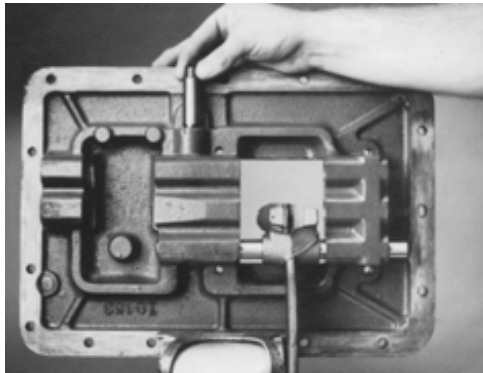

Bench Service Procedure

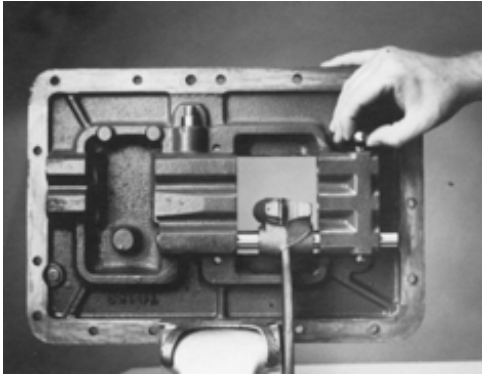

8. Install one 3/4" interlock ball.

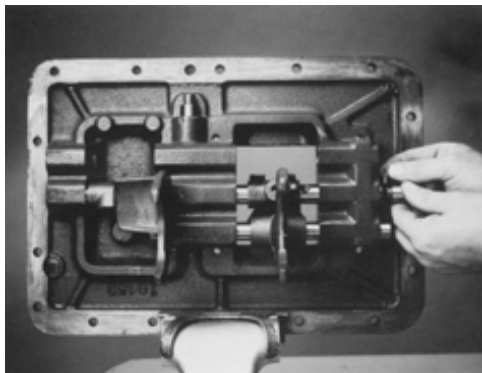

9. Insert small pin into middle yoke bar.

Note: The yoke bar and pin must be kept in line with the interlock ball bore. If the yoke bar is rotated, the pin can slide out and bind in the detent ball bore. Slide yoke bar through shift block and yoke while installing bar into center housing bore. Start the lockscrews by hand to assure proper engagement of the cone into the yoke bar hole. Torque the lockscrews to 35-45 lbs. ft.



CAUTION: Overtorquing of lockscrew can result in distortion and binding of yoke bar. Make sure yoke bar has free movement. Lockwire lockscrew.

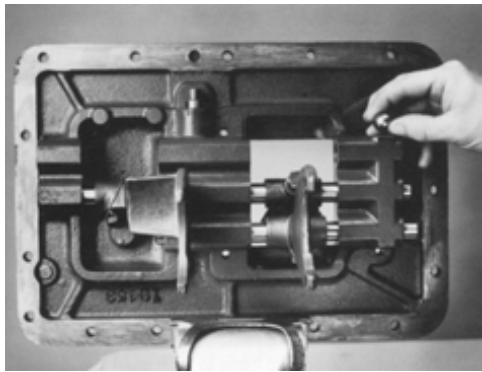

10. Install the 2nd 3/4" interlock ball.

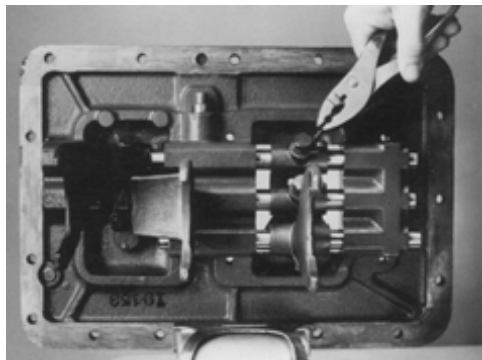

11. Install the third yoke bar into the housing. Slide through the remaining shift block and shift yoke. Start the lockscrews by hand to assure proper engagement of the cone into the yoke bar hole. Torque the lockscrews to 35-45 lbs. ft.



CAUTION: Overtorquing of lockscrew can result in distortion and binding of yoke bar. Make sure yoke bar has free movement. Lockwire lockscrew.

Bench Service Procedure

12. Install the oil trough and oil trough capscrews. Torque the lockscrews to 8-12 lbs. ft. If applicable, lockwire the screws. If lockwire holes are not present, clean threads and use a thread locking compound to retain the capscrews.
13. Insert reverse switch pin. Install gasket and reverse light switch or plug. Torque to 15-20 lbs. ft.
14. Install gasket and neutral switch or plug. Torque to 15-20 lbs. ft.
15. If used, install breather.

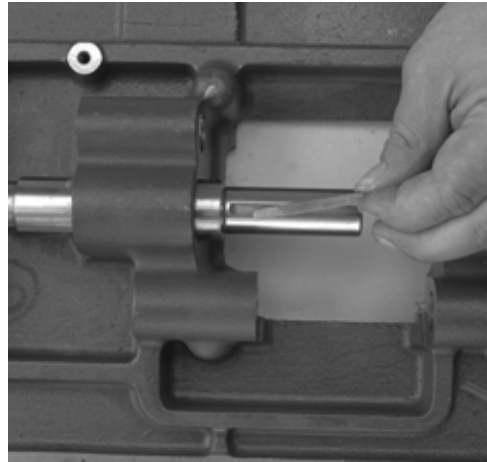

16. Install the three (3) detent balls, one in each housing top bore.

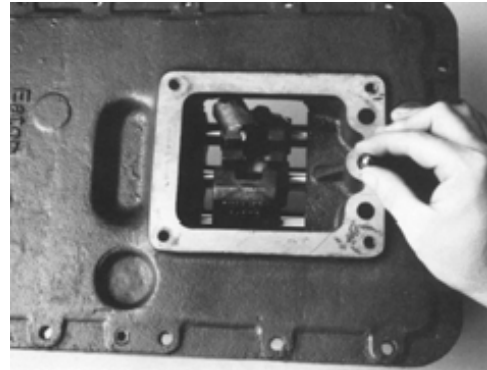

17. Install the three (3) detent springs, one over each detent ball.

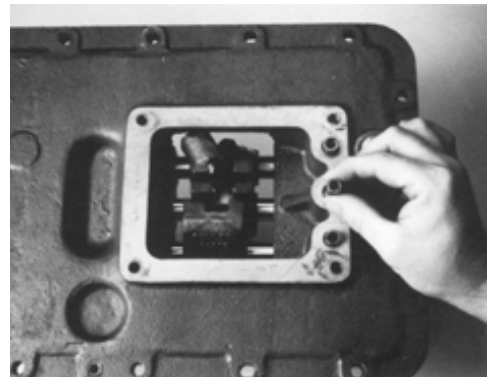

Bench Service Procedure

How to Remove the Auxiliary Section with Tapered Bearings

Special Instructions

There can be different capscrew lengths, note their location.

Auxiliary sections can be removed either with the transmission in the horizontal position or the vertical position.

Auxiliary countershaft retaining straps may be installed to hold the countershafts in place. You can make retaining straps from 3" x 1" bar stock. Auxiliary can be removed without straps, use caution.

Special Tools

See 'Tool Information'.

Item T2: Auxiliary section hanger bracket for horizontal removal

A steel bar longer than the width of the output yoke for vertical removal

A hoist with a lifting chain

Auxiliary countershaft retaining straps



Procedure -

1. To remove the auxiliary section in the horizontal position:

Remove the four (4) capscrews and the auxiliary countershaft rear bearing cover, gasket, and rear bearing shim.

Bench Service Procedure

2. Install the auxiliary countershaft retaining straps with 2 - 3/8" NC x 1" and 1 - 3/8" NC x 1 - 1/2" clean capscrews.

Note: Do not use an air gun. Tighten by hand until the capscrews are snug.

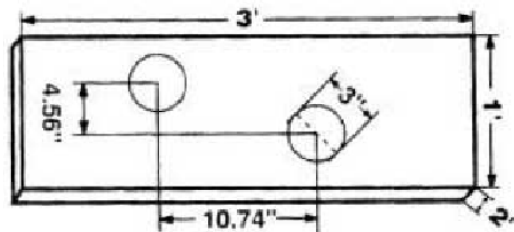

3. From the auxiliary section housing, remove the retaining capscrews that attach the front section to the auxiliary section.



4. Insert the two (2) longest capscrews in the housing flange tapped holes. Tighten evenly to move the auxiliary section away from the front box. Go far enough to break the gasket seal.
5. Remove the capscrews from the tapped holes.
6. Attach an auxiliary section hanger bracket to the auxiliary section top.
7. Attach a lifting chain to the auxiliary section hanger bracket.
8. Move assembly to the rear until auxiliary section is free.
9. Remove the gasket and clean all mounting surfaces of gasket material.



Bench Service Procedure



Procedure -

1. To remove the auxiliary section in the vertical position:

With blocks under the clutch housing to prevent input shaft damage, place transmission in the vertical position, clutch housing down.

2. Remove the four (4) capscrews and the auxiliary countershaft rear bearing cover, gasket, and rear bearing shim. Clean the gasket surface area.

3. Install the auxiliary countershaft retaining straps with 2 - 3/8" NC x 1" and 1 - 3/8" NC x 2 - 1/2" clean capscrews.

Note: Do not use an air gun. Tighten by hand until the capscrews are snug.

4. From the auxiliary section housing, remove the retaining capscrews that attach the front box to the auxiliary section.

5. Install a steel bar through the yoke.

6. Attach a lifting chain to the steel bar.

7. Lift assembly from the front section.

How to Disassemble the Range Cylinder Assembly

Procedure -

1. From the range cylinder cover, remove the capscrews, cover, and gasket.
2. Clean the gasket mounting surfaces of all gasket material.
3. From the range cylinder housing bore, remove the 15/16" nut.
4. Remove 3/4" bolts from range yoke.

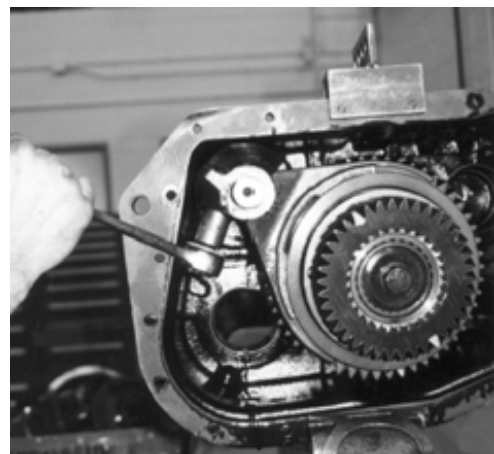
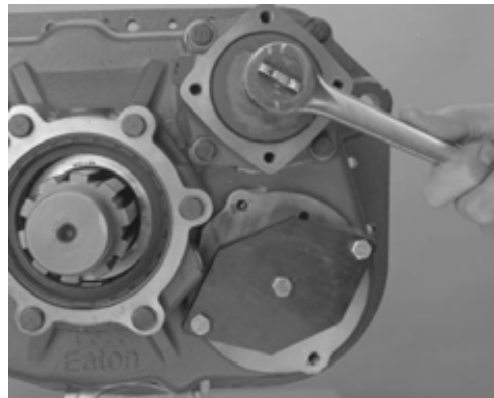
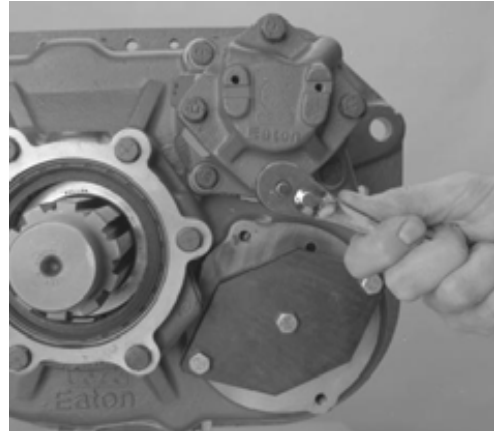

Bench Service Procedure

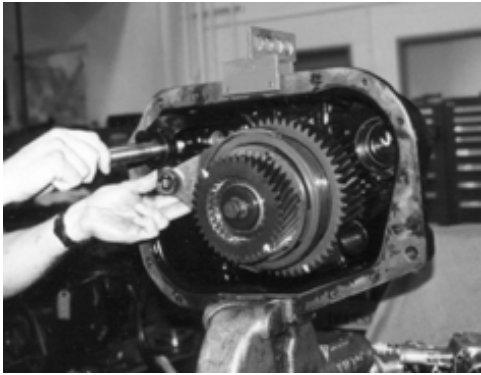

5. Pull range shaft out of cylinder and remove range yoke from synchronizer.

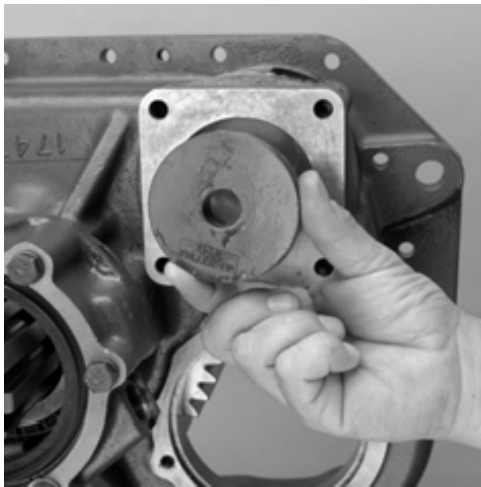

6. From the cylinder housing bore, remove the range piston.



7. Inspect the range piston O-rings, remove if damaged.

Bench Service Procedure

8. From the range cylinder housing, remove the housing and gasket.
9. Clean the gasket mounting surfaces of all gasket material.

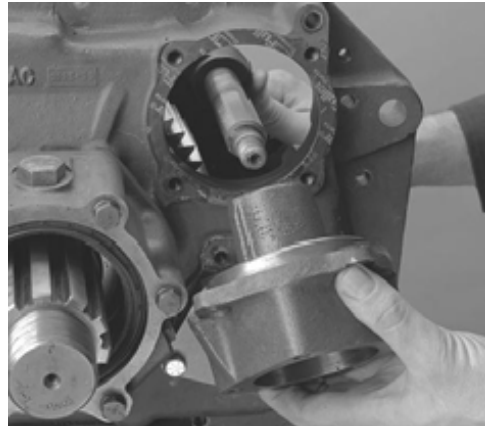

10. Inspect the O-ring inside the range cylinder housing bore, remove if damaged.

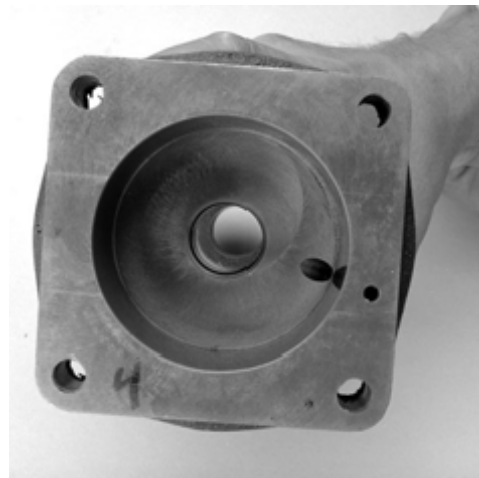

Bench Service Procedure

How to Remove the Auxiliary Countershaft Assembly

Special Instructions

For ease of disassembly, mount the auxiliary section upright in a vise.

Both countershafts are removed the same.

As the countershaft strap is removed, the countershaft can fall.

Special Tools

See "Tool Information".

Vise with brass jaws or wood blocks

Item T11: Bearing Puller

Soft bar and maul

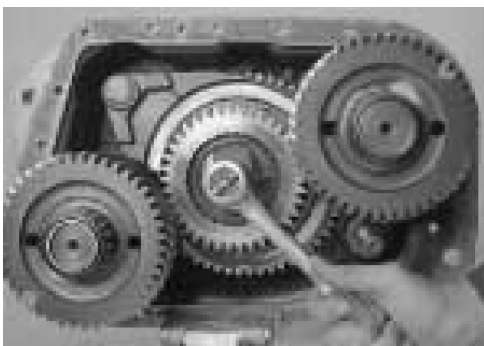
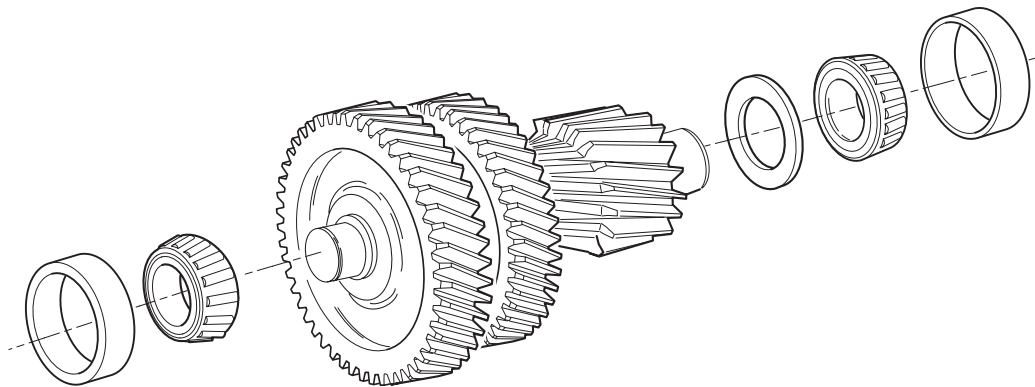

Procedure -

1. To hold the auxiliary countershafts from turning, place a shop rag or equivalent between the splitter gear and one countershaft.
2. From the output shaft, loosen the 15/16" capscrew and retainer. Do not remove the capscrew.

Bench Service Procedure

3. Install countershaft retaining strap.



4. Use a soft bar and maul to drive the output shaft forward far enough to partially unseat the bearing.



5. Support the auxiliary countershaft while removing the auxiliary countershaft retaining strap.

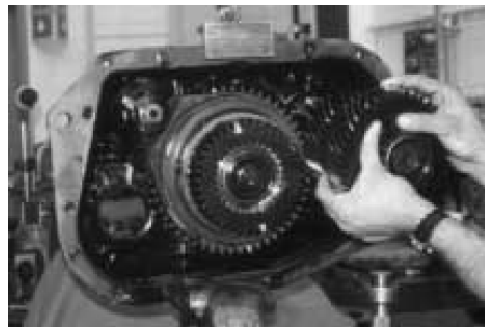

6. Remove the auxiliary countershaft.

7. Remove the auxiliary countershaft bearing race from bore.



Bench Service Procedure

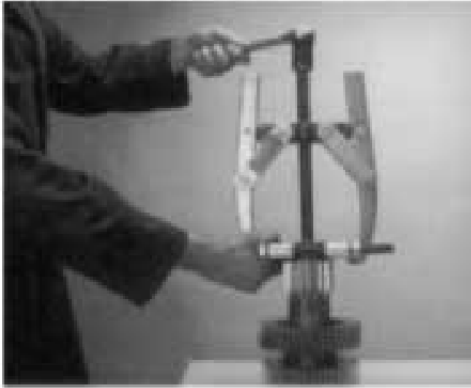

8. If necessary, secure the countershaft assemblies in a vise and remove both the front and rear bearings with a bearing separator and jaw pullers.



How to Disassemble the Synchronizer Assembly

Special Instructions

Place the synchronizer assembly on a clean, flat surface. Cover the synchronizer assembly with a shop rag to prevent losing the three (3) springs under pressure from the HI range synchronizer pin locations.

Special Tools

Typical service tools

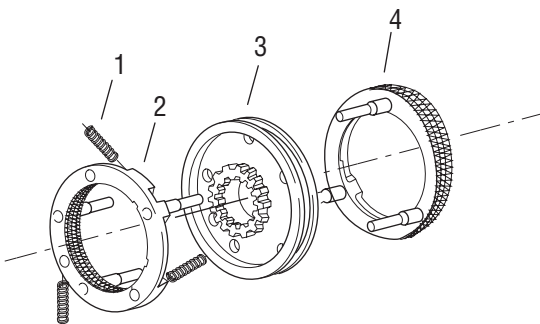

1. Spring
2. Synchronizer Hi
3. Sliding Clutch
4. Synchronizer Lo

Procedure -

1. Place the larger LO range synchronizer ring on the bench.
2. Cover the synchronizer with a shop rag to contain the springs.
3. Grab both sides of the HI range synchronizer and pull.
4. From the synchronizer ring LO range pins, remove the sliding clutch.



Bench Service Procedure

How to Disassemble the Output Shaft Assembly

Special Instructions

When using the soft bar and maul on the output shaft, be careful not to damage the threads.

When removing the rear bearing cover, the rear bearing cone drops from the housing bore.

Special Tools

Vise with brass jaws or wood blocks

Press

Soft bar and maul

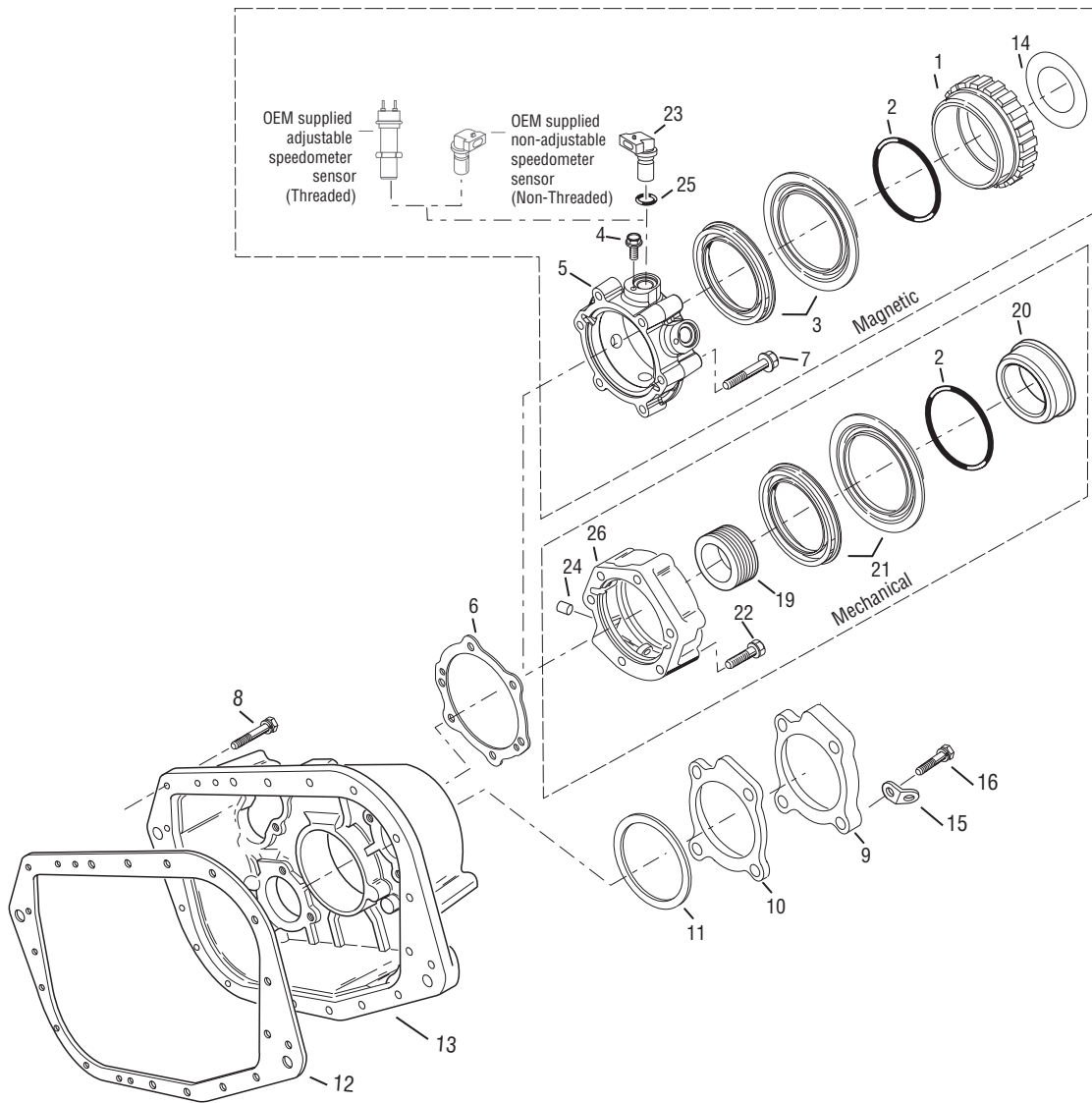

1 - Speedo rotor assembly

2 - O-ring

3 - Oil seal kit

4 - Capscrew

5 - Rear bearing cover assembly

6 - Gasket

7 - Capscrew

8 - Capscrew

9 - Cover

10 - Gasket

11 - Shim Kit

12 - Gasket

13 - Rear housing

14 - Slinger

15 - Lifting eye

16 - Capscrew

19 - Speedo drive gear

20 - Speedo spacer assembly

21 - Oil seal w/slinger

22 - Capscrew

23 - Speed sensor kit

24 - Bushing

25 - O-ring

26 - Rear bearing cover assembly

Bench Service Procedure



Procedure -

1. Use a soft bar and maul to drive the output shaft forward and through the rear bearing assembly.

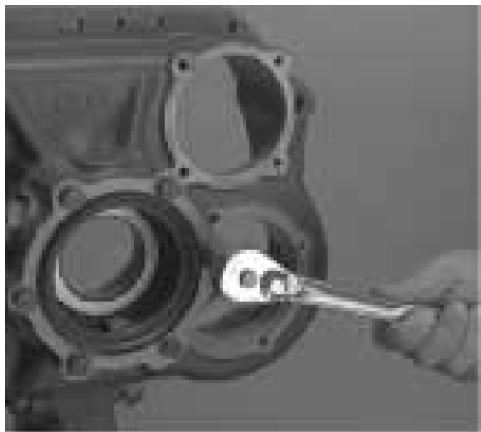

2. From the auxiliary housing rear, remove the rear bearing retaining cap screws, cover, and gasket.

3. Clean the gasket mounting surface of gasket material.



4. Inspect the rear bearing cover oil seal for damage, remove if damaged.

Bench Service Procedure

5. From the auxiliary housing rear, remove the bearing cup and spacer.



6. From the auxiliary housing front, remove the remaining bearing cup.



7. Some models have a one piece bearing race. Remove it from the bearing bore.



Bench Service Procedure



8. From the output shaft, remove the bearing inner spacer.



9. Use the output shaft assemble gear front face as a base, press the output shaft through the bearing and gear.

How to Assemble the Output Shaft Assembly

Special Instructions

Make sure the magnetic plugs are installed in the auxiliary housing.

Output shaft stack up should be done on a clean, flat surface.

When heating the bearings, do not heat above 275°F (136°C).

When installing the rear bearing race, the proper depth is when the race shoulder is seated on bearing bore top.

Because the collar becomes distorted when compressed, do not use an old nylon collar in the rear bearing cover.

Special Tools

See "Tool Information."

Toolmaker's dye

Heat lamp or hot plate and oil

Oil seal installation tool

Procedure -

1. Use toolmaker's dye and mark the LO range gear for timing purposes.
2. Mark any two (2) adjacent teeth on the LO range gear. Repeat the procedure for the two (2) adjacent teeth directly opposite the first set marked.



Bench Service Procedure



3. With splined washer facing up, place the washer on the output shaft shoulder.



4. With LO range gear clutching teeth down, position LO range gear on the output shaft, engage the washer splines.

5. With chamfer side up, position the LO range gear rear washer on the output shaft against the LO range gear.

6. With tapered side up, use heat or appropriate driver and install the output shaft rear bearing.

7. On the output shaft, position the bearing inner spacer. Set aside.

8. Lay the auxiliary housing front face down on a clean flat surface. Install the bearing race in the bearing bore.



How to Assemble the Synchronizer Assembly

Special Instructions

Assembly should be done on a clean, flat surface slightly lower than your waist.

Pins on the LO range synchronizer must line up with the chamfered holes on the sliding clutch bottom.

When compressing the HI range synchronizer springs cover with a shop rag. In the event compression is not achieved the first time, this prevents the springs from leaving the bench area.

Special Tools

Typical service tools

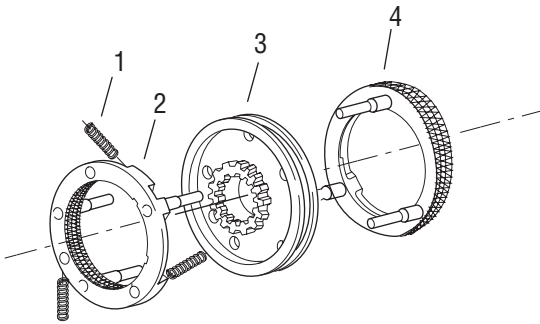

1. Spring
2. Synchronizer Hi
3. Sliding Clutch
4. Synchronizer Lo

Procedure -

1. On the bench place the larger LO range synchronizer ring face down with pins up.
2. With the sliding clutch recessed side up, place the sliding clutch on the LO range synchronizer pins.



Bench Service Procedure



3. In the HI range synchronizer bores, install the three (3) springs.



4. Place the HI range synchronizer ring over the LO range synchronizer ring. Rotate the HI range synchronizer until the springs are seated against the pins.
5. Cover the assembly with a shop rag.



6. Apply downward pressure to the HI range synchronizer ring while twisting counterclockwise. This compresses the springs to fully seat HI range on the LO range synchronizer. This should be done with a rapid twist and push motion.

Note: Make sure there are three springs and they are fully compressed.

Note: Make sure you can move the sliding clutch from HI to LO range and back.

How to Install the Oil Seal

Special Tools

See Tool Information Eaton Aftermarket Tools for part numbers.

Oil seal driver

Oil seal slinger driver

Procedure -

1. Install the seal into the rear bearing cover using the proper seal driver. The seal is fully installed when the flange on the seal is flush with the shoulder in the bore.



2. Install a new slinger on the seal sleeve or output yoke using a slinger driver.

Note: Some versions use a sealing ring which is pressed into a groove on the seal sleeve rear. Make sure this seal is in place on this design level.



Bench Service Procedure

How to Assemble the Range Cylinder Assembly

Special Instructions

Apply Eaton lubricant #71214 or equivalent to shift cylinder assembly and insert valve O-rings so a film covers the entire surface of each O-ring.

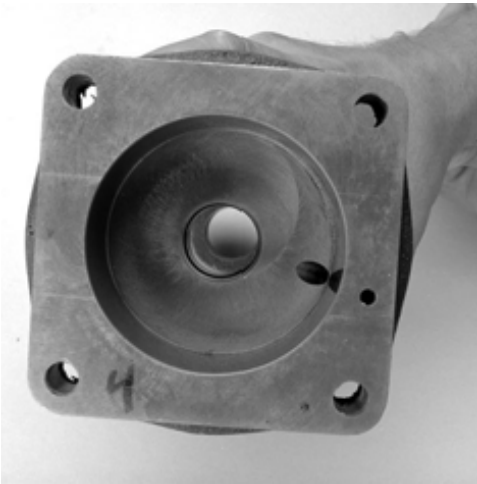

Procedure -

1. If previously removed, in the cylinder housing bore, install the small O-ring.
2. If previously removed, on the piston I.D. and O.D., install the piston O-rings.
3. Position a new gasket on the range cylinder housing mounting surface.
4. Install the cylinder housing.
5. Apply Eaton/Fuller sealant #71205 or equivalent to the retaining capscrews.
6. Install the capscrews, tighten to 20-25 lbs. ft. of torque.

Bench Service Procedure

7. Lean auxiliary section back with range cylinder upward.

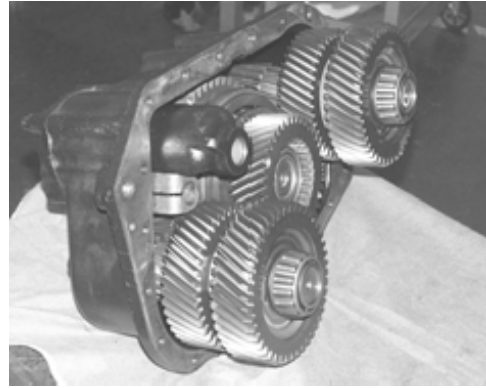

8. Insert the piston. Push it in as far as it will go.



9. Slide range bar through the cylinder and yoke, aligning grooves on range bar with bolt holes in range yoke.



10. Apply Eaton Fuller sealant #71205 or equivalent to range yoke bolts. Install bolts and torque to 50-65 lbs. ft. of torque.

11. Secure the piston with the retaining nut, tighten to 70-85 lbs. ft. of torque.

12. Position a new gasket on the cylinder housing cover mounting surface.



Bench Service Procedure

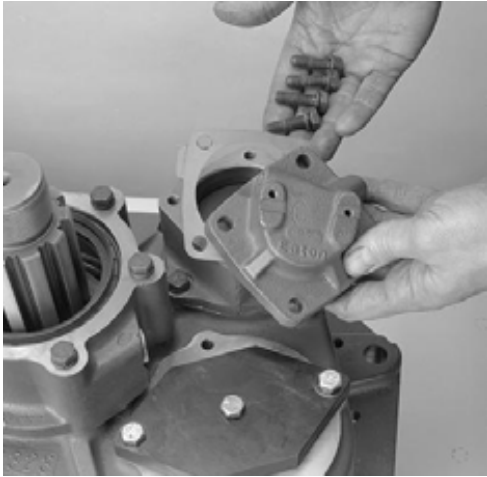

13. Over the gasket, position the range cylinder cover.

14. Apply Eaton/Fuller sealant #71205 or equivalent to the retaining capscrews.

15. Install the capscrews, tighten to 20-25 lbs. ft. of torque.

Final Check

Make sure all capscrews are tighten to their proper torque.

Make sure gaskets were used at the appropriate positions.

How to Install the Countershaft Assemblies

Special Instructions

To make auxiliary section assembly easier, you can make an auxiliary section fixture out of a 2" x 12".

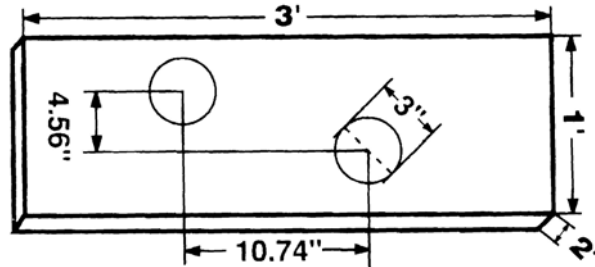

Make sure to use an auxiliary drive gear retaining bolt with thread sealant material.

Special Tools

See "Tool Information".

Toolmaker's dye

Item T12: Bearing driver

Shim gauges or countershaft retaining straps

Procedure -

1. If previously removed, install the countershaft bearings on each of the countershafts.

IMPORTANT: Locate the "O" stamped in each countershaft and mark the adjoining teeth with a highly visible paint or dye.



Bench Service Procedure



2. Place the two countershaft in the fixture or on a flat bench with the large HI range gears down.



3. Position the output shaft, LO range and synchronizer assembly between the two countershaft.

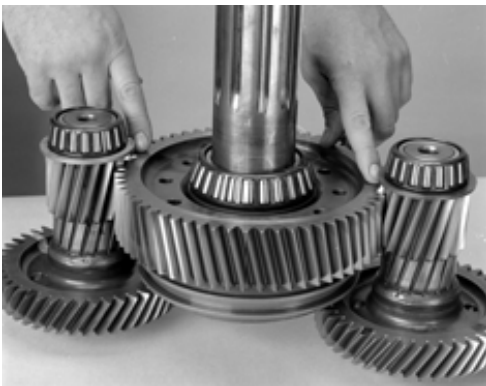

4. Check the timing marks on the LO range gear, making sure the countershaft gear timing marks are aligned between the LO range gear teeth.

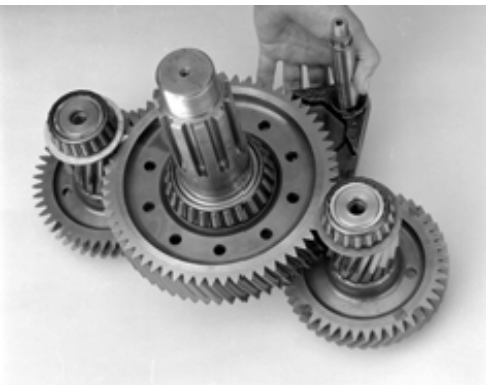

5. Place the range yoke assembly into the synchronizer sliding clutch.

Bench Service Procedure

6. Place the auxiliary housing over the output shaft and countershaft assemblies.

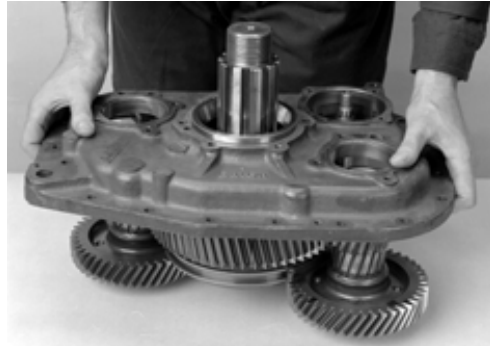

7. Install the two rear countershaft bearing races in the auxiliary section bores.



8. Place the shim gauges over each bearing, install capscrews 1-2-1/2 x 3/8", and 2-1" x 3/8".



9. **TIGHTEN ALL CAPSCREWS ONLY UNTIL SNUG.** Countershaft retaining straps may also be used.

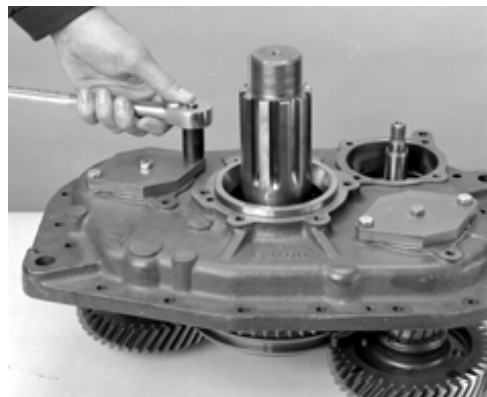

Bench Service Procedure

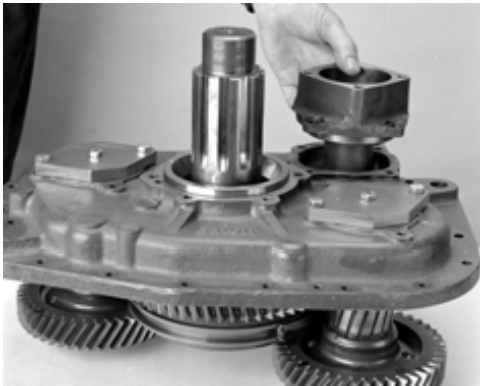

10. Install range cylinder into auxiliary section bore.

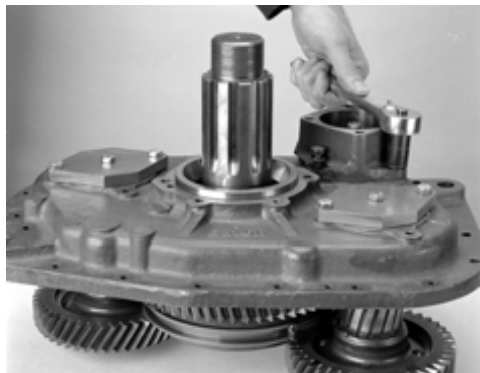

11. Torque capscrews to required torque.

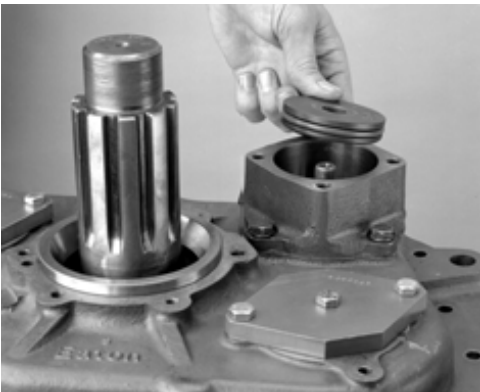

12. Place range piston in cylinder bore.



13. Torque piston retaining nut to recommended specification.

Bench Service Procedure

14. Position new gasket and range cylinder cover on the range cylinder and tighten to recommended torque.

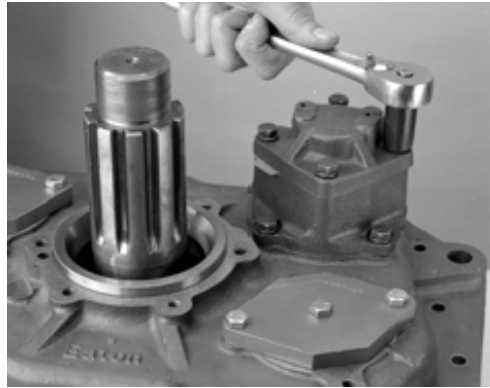

15. Install bearing spacer on the output shaft.



16. Heat the rear bearing and place it on the output shaft until seated.

Note: Do not heat the bearing above 275°F (136°) use a bearing heater if possible.

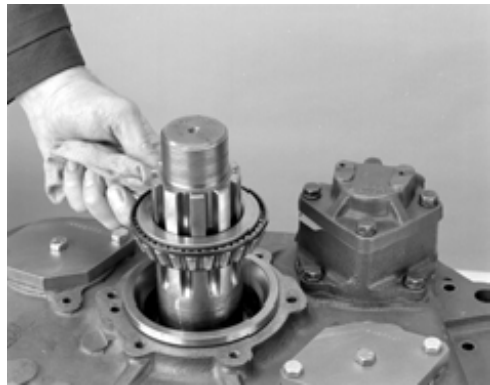

17. Position the rear bearing cover and gasket on housing, tighten bolts to recommended torque.

Note: One rear bearing capscrews hole is chamfered the nylon collar and brass washer must be installed at this location to correctly seal the rear bearing cover. DO NOT REUSE OLD NYLON COLLAR.

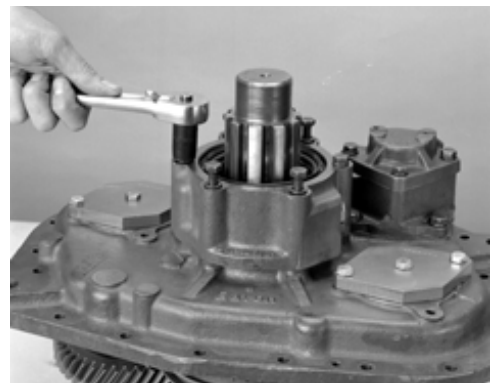

Bench Service Procedure

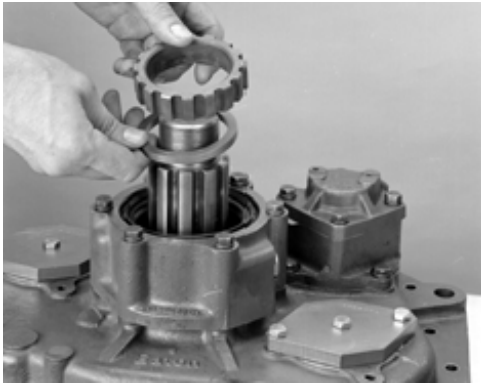

18. Spacer must be installed between bearing and speedometer drive gear.



19. Install output yoke and nut on output shaft, for installation of auxiliary section to the main case.

How to Remove the Clutch Housing (with Internal Oil Tube)

Special Instructions

Removal of the clutch housing is performed in the horizontal position.

The clutch release mechanism must be removed.

Some early production models do not have an oil tube behind the clutch housing. For these models, skip step 5.

Special Tools

Typical service tools

Procedure -

1. From inside the clutch housing, remove the nuts and washers.

Note: Depending on the transmission model, the clutch housing may have 10 or 12 bolts.

2. From inside the clutch housing, remove the capscrews.
3. Jar clutch housing to break gasket seal.

4. Pull the clutch housing from the studs and transmission case.

5. If oil tube is not being removed skip to step 10.

6. Remove oil tube.

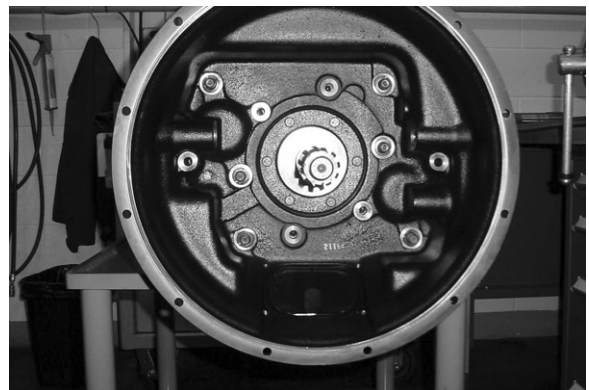

Bench Service Procedure

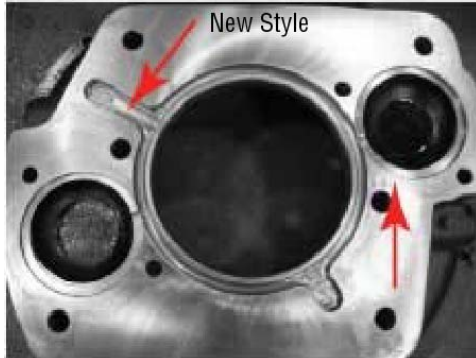

7. Remove the gasket and clean all mounting surfaces of gasket material.
 - a. Without oil tube channel (Older style)
 - b. With oil tube channel (New style)

Note: Clutch housing with oil channel can be used on transmissions without the oil tube.

How to Install the Clutch Housing (with Internal Oil Tube)

Special Instructions

Installation of the clutch housing is performed in the horizontal position.

IMPORTANT: Some early production models do not have an oil tube behind the clutch housing. For these models skip steps 3, 4, and 5.

The oil tube comes in two different lengths. The older units extend 2/3 of the way through the front box. The new units go into the intermediate wall that separates the main case from the auxiliary case (see step 5).

Special Tools

Typical service tools

Procedure -

1. Position a new gasket on the housing mounting surface with the bead toward the case.

Note: If the front bearing cover was removed, it needs to be installed before the clutch housing to ensure correct alignment of the clutch housing.



2. Make sure gasket is orientated so that all bolt holes and lube passage holes are showing.
3. If oil tube is not being replaced follow steps 8-10.
4. Inspect O-rings on oil tube and replace if damaged.

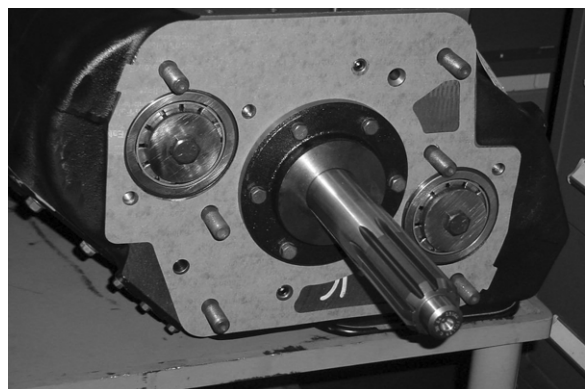

Bench Service Procedure



5. Apply Eaton Fuller silicone lubricant #71203 to O-rings and install oil tube in case.



6. Press oil tube firmly into place.

Bench Service Procedure

7. The oil tube has two different lengths. Older units extend 2/3 of the way into the main case and newer units go into the intermediate wall. Make sure the lube tube seats properly.

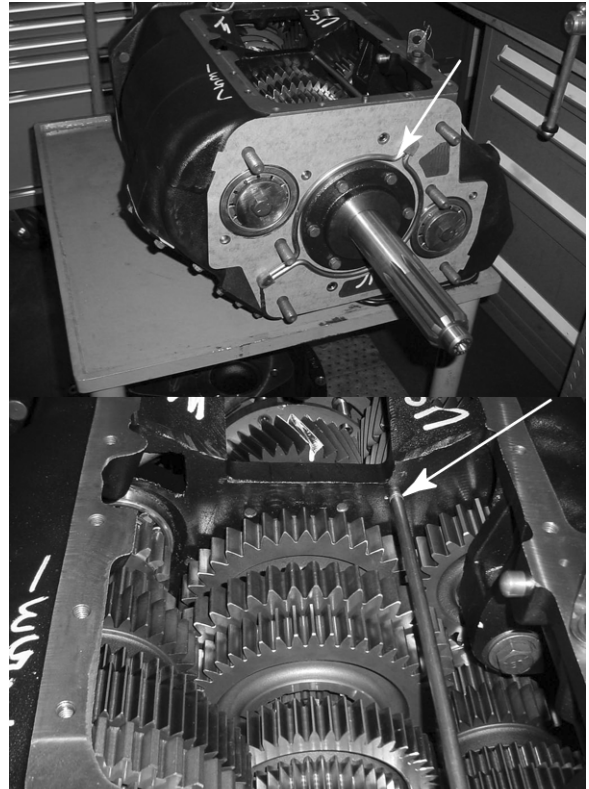

8. Install the clutch housing on the front box, pilot it on the six studs and front bearing cover.



9. Install the nuts with washers or lock washers on the studs, tighten to 180-190 lbs. ft. of torque.

10. Install the capscrews with lock washers, tighten to 90-100 lbs. ft. of torque.

Note: Make sure the capscrews are properly torqued.

Note: Depending on the transmission model, the clutch housing may have 10 or 12 bolts.

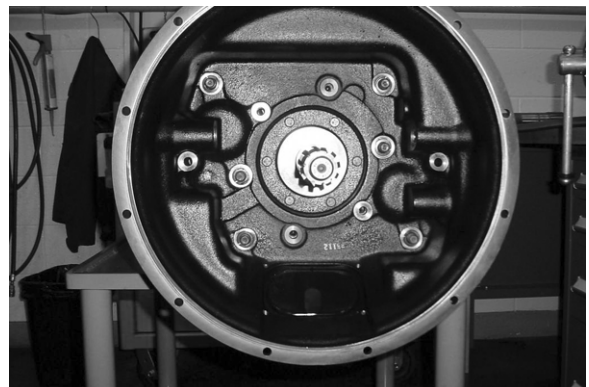

Bench Service Procedure

How to Remove the Standard Torque Auxiliary Drive Gear Assembly

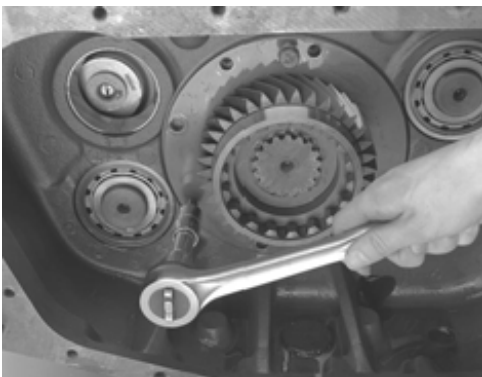
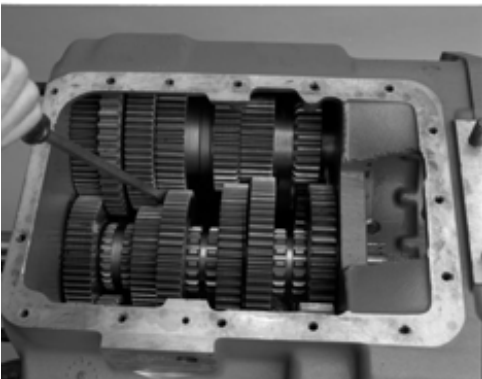
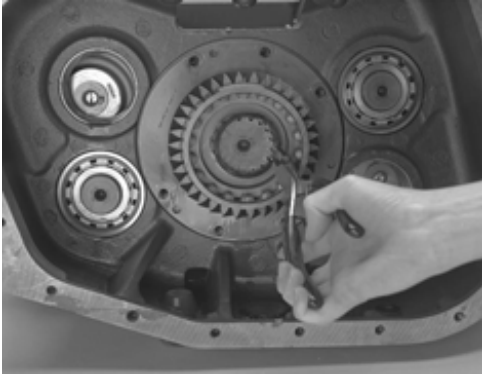

Procedure -

1. Remove the mainshaft rear groove snap ring.
2. Remove the six (6) auxiliary bearing retainer ring cap-screws and bearing retainer ring.
3. Insert a prybar into the main case gearing and use it to slide the mainshaft assembly rearward to move the auxiliary drive gear bearing from its bore.
4. If it does not move easily, it may be necessary to install three capscrews in the threaded holes on the retainer plate. Tighten the three screws evenly to force the auxiliary drive gear assembly from the case. The 3 threaded holes are only found on earlier models.

How to Disassemble the Upper and Lower Reverse Idler Gear Assembly

Special Instructions

The new reverse idler shaft uses a snap-ring on the front in place of the capscrew.

Lower reverse idler gear removal is the same, but the mainshaft and countershafts must be removed.

Special Tools

- Slide Hammer T5 (see Table 6)

Previous Design

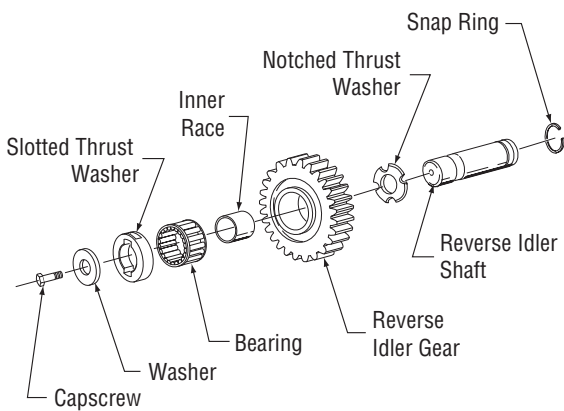

Current Design

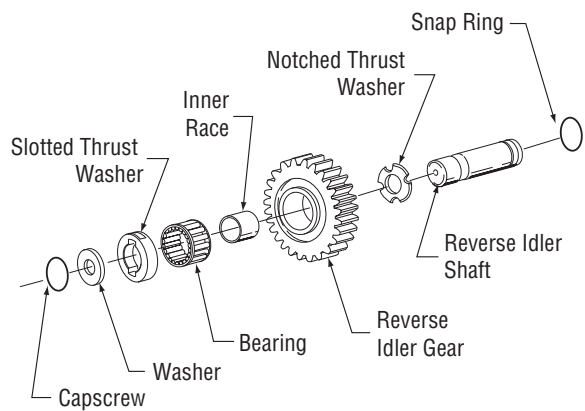

Procedure -

1. Remove the capscrew (or nut) on the front of the reverse idler shaft.

Note: If idler shaft spins, place a large screwdriver between reverse idler boss to keep shaft from spinning.

2. (On new design idler shafts remove the snap ring).

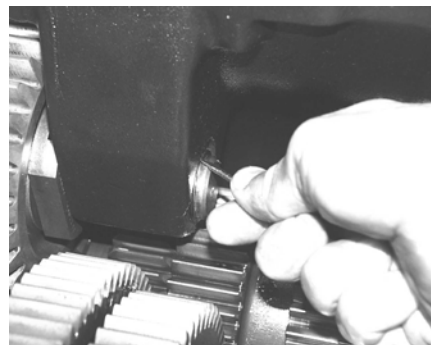
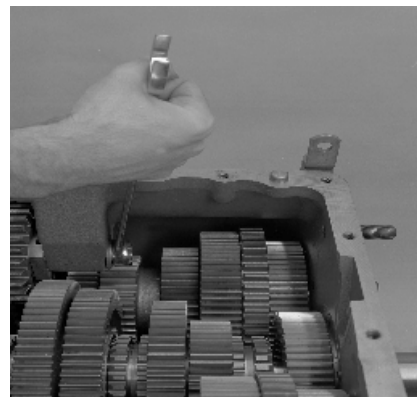

Bench Service Procedure

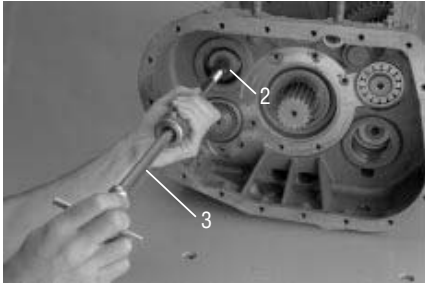

3. Thread a slide hammer puller (Tool ref. ID T5) into the rear of the reverse idler shaft. The threads are M12x1.75.

Note: Not all shafts styles had threads.

4. Using the slide hammer, remove the reverse idler shaft.

Note: If a slide hammer is not available, the reverse idler can be driven out as shown in the photo.

Note: While removing the reverse idler shaft, the lube spacer and washer can drop to the transmission case bottom.

Note: If desired, the upper reverse idler gear can be removed without removing the mainshaft. To do so, remove the snap ring from the mainshaft reverse gear, and move the mainshaft reverse gear forward.

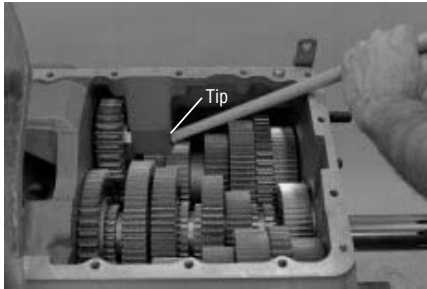

How to Remove the Upper and Lower Countershaft Bearings

Special Instructions

The following instructions are used to remove the upper and lower countershaft bearings. To remove the mainshaft assembly, only the upper countershaft bearings need to be removed.

Performing the following instructions will damage the bearings and should be not be done unless bearing replacement is planned.

The bearing inner race remains pressed on the countershaft after removal of the front bearings.

Special Tools

See "Tool Information" on page 16..

Soft bar and maul

Item T6: Bearing puller or pry bars

Procedure -

1. To keep the mainshaft pilot from falling out of the input shaft pocket, temporarily install the auxiliary drive gear on the mainshaft.
2. From each countershaft rear groove, remove the snap ring.
3. Remove six capscrews from front bearing cover and remove front bearing cover.
4. From inside the case, use a soft bar and maul to drive the countershaft rear bearings rearward off the shaft.



CAUTION: Damage will likely occur to this bearing during removal. It is strongly recommended that this bearing is discarded.



Bench Service Procedure



5. From the front of each countershaft, remove the capscrew and front retainer plate.
6. Use the soft bar and maul to drive each countershaft to the rear as far as possible. This partially unseats the front bearings.
7. Return to the case rear, and drive each countershaft forward as far as possible. This exposes the external snap ring.

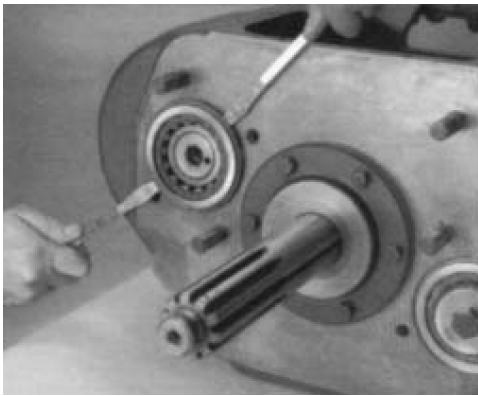

8. Use the appropriate bearing puller or pry bars to remove the countershaft front bearings.

How to Remove the Input Shaft and Main Drive Gear

Special Instructions

None

Special Tools

See "Tool Information."

Item T16: Bearing puller

Soft bar and maul

Procedure -

1. From the front bearing cover, remove the six (6) retaining capscrews and cover. Remove any remaining gasket material from the case and cover.
2. present, remove and discard the rubber seal ring on the input shaft. The ring is used only to seal the transmission during shipment.



Bench Service Procedure



3. From the input shaft groove, remove the bearing retaining snap ring.



4. Use a soft bar and maul to drive the input shaft toward the case rear as far as possible. Pull the input shaft forward.

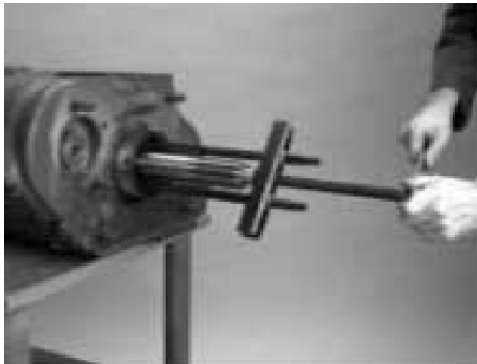

5. Install the bearing puller tool and remove the input bearing from the case and input shaft or use pry bars or screwdrivers to complete removal of the bearing.

6. From the drive gear front, remove drive gear spacer.



Bench Service Procedure

7. Remove the drive gear internal snap ring.

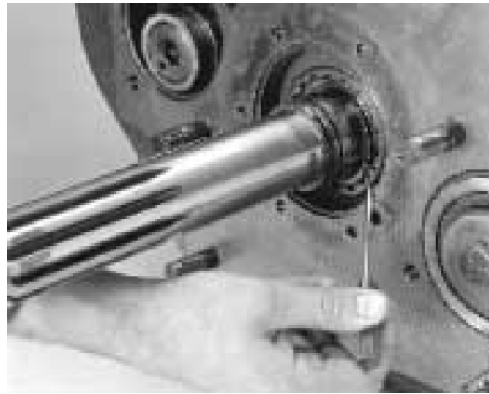

8. Pull the input shaft forward and out of the drive gear.



9. From inside the case, remove the drive gear.

10. Inspect the bushing in the input shaft pocket, replace if damaged.



Bench Service Procedure

How to Remove the Mainshaft Assembly

Special Instructions

None

Special Tools

See "Tool Information."

Item T15: Mainshaft hook



Procedure -

1. Secure the upper countershaft to the side and away from the mainshaft. Optional: Insert prybar between upper countershaft and main drive gear as shown.

2. Insert the mainshaft hook tool or rope around the mainshaft.

Note: Keep the upper countershaft forward against the case front wall.

3. Pull the mainshaft to the rear to free the pilot from the input shaft pocket.



WARNING: Be careful when removing the mainshaft assembly. The sliding clutch on the front and the reverse gear on the back can slip off the shaft.

Bench Service Procedure

4. Tilt the mainshaft front up and lift the assembly from the case.



Bench Service Procedure

How to Disassemble the Mainshaft Assembly

Special Instructions

During disassembly, lay all parts on a clean bench in order of removal to facilitate reassembly.

When removing limit washers, spacers and gears, note their location. Keep the internal-splined washers and external-splined spacers with the gear from which they were removed. There is only one limit washer and one spacer belonging to each gear.

Mainshaft assembly construction varies with transmission model type. Some of the following steps will only apply to certain model configurations. Refer to the specific model parts catalog if you are uncertain if parts are applicable. The following illustrations may differ slightly from the exact model and design level you are servicing.

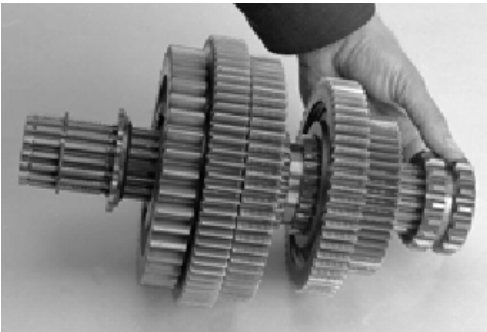
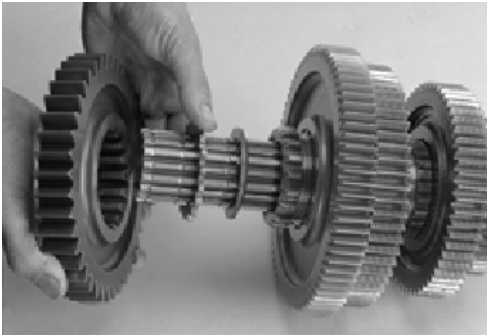

Procedure -

1. Remove reverse gear.
2. Remove reverse gear spline spacer.
3. Tilt the mainshaft up, and from the opposite end, remove the sliding clutch

4. Some models use a flat key at the front, remove this key. Rotate the spline washer that is retained by this key to remove the front gear and washers.

TIP: To make disassembly easier, clamp the mainshaft front in a vise with brass jaw protectors.

5. Place the mainshaft in a vertical position.

Bench Service Procedure

6. From the mainshaft rear, pull the mainshaft key from the mainshaft key way.



7. Turn the reverse gear limit washer to align its splines with the mainshaft and remove the washer.
8. Remove the reverse-1st speed sliding clutch.

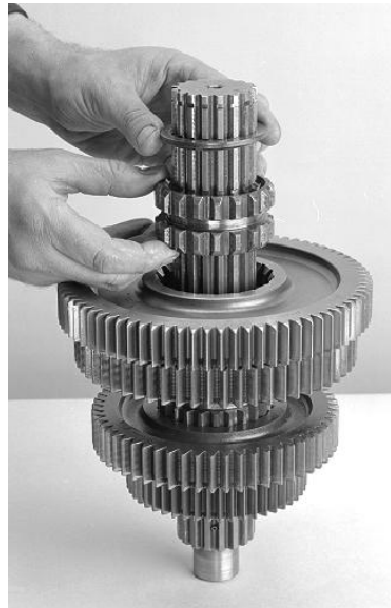

Bench Service Procedure

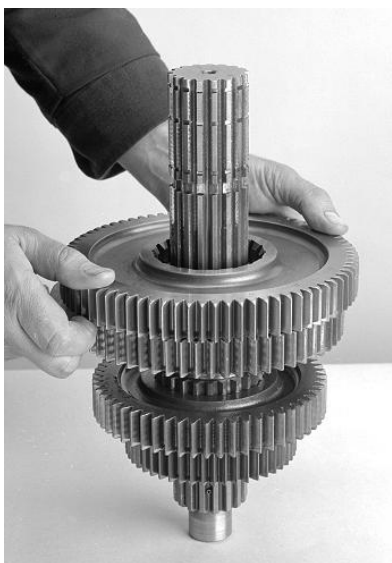

9. Lift and turn 1st gear to align the limit washer splines.



10. Remove the limit washer, spacer and 1st gear.

Bench Service Procedure

11. Turn the 2nd gear limit washer to align its splines with the mainshaft. Remove 2nd gear and its limit washer.
12. Remove the 2nd-3rd sliding clutch.



13. Remove each remaining gear, limit washer, and spacer.
14. Inspect the roll pin, remove if damaged.

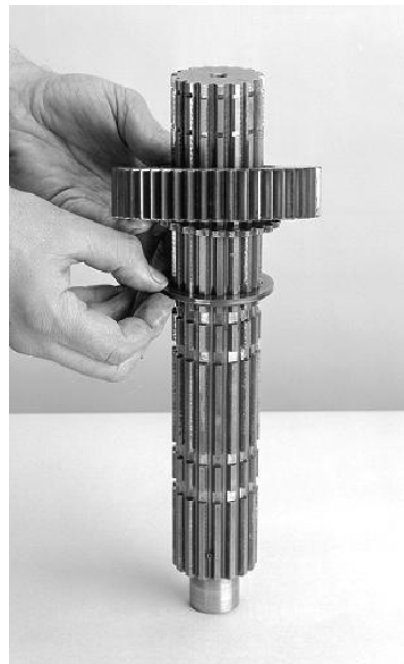

Transmission Overhaul Procedures-Bench Service

How to Disassemble the Mainshaft Assembly with Low Force Gearing

Special Instructions

The design of the mainshaft with Low Force Gearing is slightly different from the standard mainshaft. It still utilizes Non-Selective (Non-Adjustable) Tolerance Washers, but the 1st and reverse gears and sliding clutch have been redesigned. In this configuration, the 1st/reverse sliding clutch rides on a clutch hub, and the 1st and reverse gears have been redesigned to accommodate this change.

Lay all parts on a clean bench in order of removal to facilitate assembly.

Special Tools

- Typical service tools

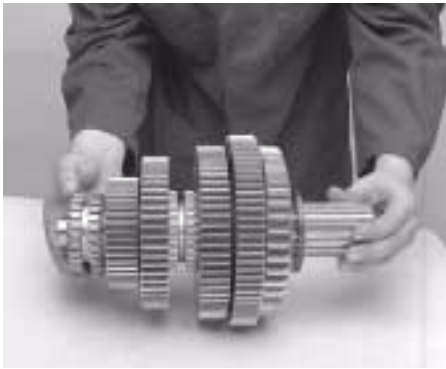

Procedure -

1. Lay the mainshaft on its side, and from the front, remove the 4th (or overdrive) and 5th sliding clutch.
2. Place the mainshaft in a vertical position, pilot end down. Remove the reverse gear, clutch hub, and sliding clutch.
3. Remove the snap ring and key. Mark keyway location.

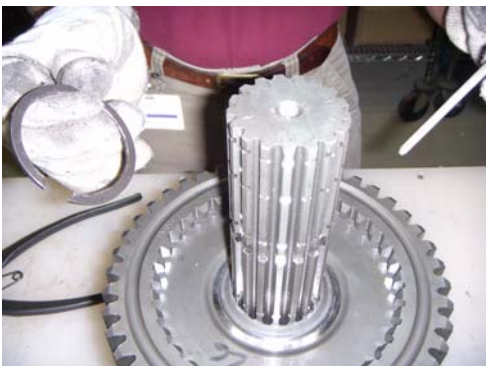

Transmission Overhaul Procedures-Bench Service

4. Remove the offset washer and 1st gear.



5. Remove the flat washer and 2nd gear.



6. Remove the offset washer and sliding clutch, and then remove the offset washer and 3rd gear.



7. Remove the flat washer, remove the 4th or overdrive gear, and remove the offset washer.



Bench Service Procedure

How to Remove the Countershaft Assemblies

Special Instructions

Except for the PTO gears, the upper and lower countershaft assemblies are the same. Mark the countershafts as UPPER or LOWER as you remove them.

The mainshaft and main drive gear must be removed before removing the countershaft assemblies.

Special Tools

Typical service tools

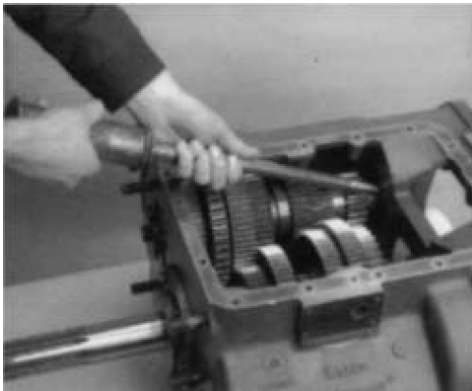

Procedure -

1. Mark the countershafts as UPPER or LOWER as you remove them.

Note: The mainshaft and main drive gear must be removed before removing the countershaft assemblies.

2. Remove the rear snap ring from the rear upper countershaft bearing.

3. From inside the case, use a long soft bar to drive the upper countershaft rear bearing rearward off the shaft.

Note: Damage will likely occur to this bearing during removal. It is strongly recommended that this bearing is discarded.

4. Remove the capscrew and the retainer from the upper countershaft front.

5. Slide the lower countershaft forward. This will move the front bearing forward to expose the external snap ring.

Bench Service Procedure

6. Use the appropriate bearing puller (Tool ID T6) or two prybars to remove the lower front bearing from its bore.
7. Move the upper countershaft to the rear until the front bearing journal clears the front case bore.



8. Swing the front of the countershaft to the center of the case, and lift out the countershaft assembly.

Note: A large hook or piece of rope may help support the countershaft.

Note: Follow the same procedure for lower countershaft removal.



Bench Service Procedure

How to Disassemble the Countershaft Assemblies

Special Instructions

As you disassemble the countershafts, mark each part as belonging to the upper or lower countershaft and mark the gears for front or back orientation.

Except for the PTO gears, the left and right countershaft assemblies are identical and disassembled in the same manner.

Special Tools

See "Tool Information."

Snap ring pliers

Press

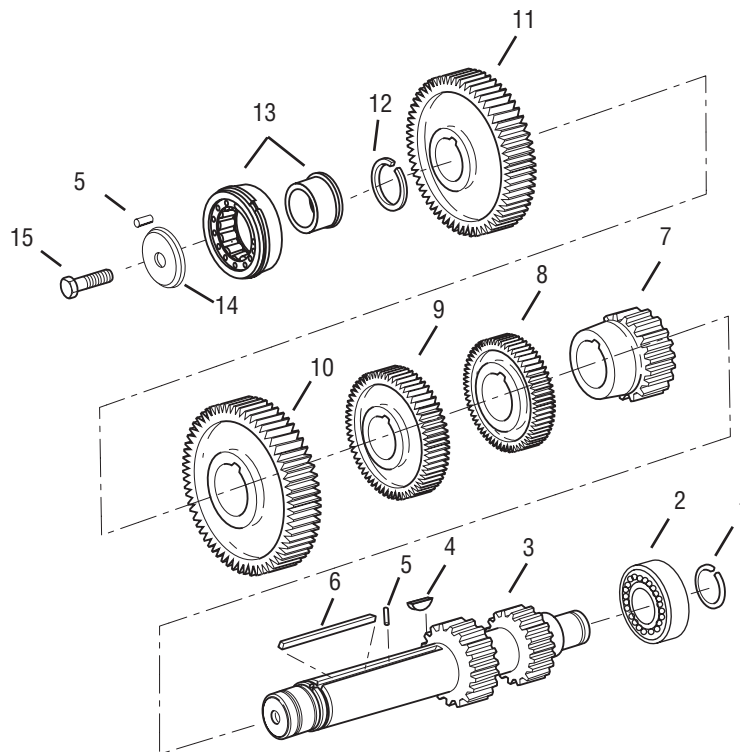

1 - Snap Ring

2 - Bearing

3 - Countershaft

4 - Key

5 - Roll Pin

6 - Key

7 - 2nd Gear

8 - 3rd Gear

9 - 4th Gear

10 - PTO Gear

11 - Drive Gear

12 - Snap Ring

13 - Bearing

14 - Retainer

15 - Capscrew

Procedure -

1. Remove the front countershaft snap ring.



CAUTION: NEVER USE THE PTO GEAR AS A PRESSING BASE. The narrow face width of this gear makes it very susceptible to breakage.

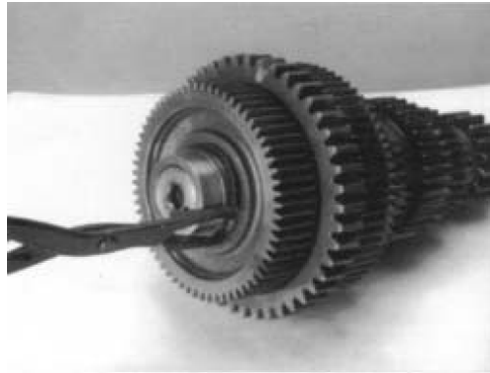

2. Place the countershaft in the press as shown. Using the rear face of 3rd/Overdrive speed gear as a base, press the drive gear, PTO gear, and 3rd/Overdrive speed gear from each countershaft. This removes the front bearing inner race from the countershaft.

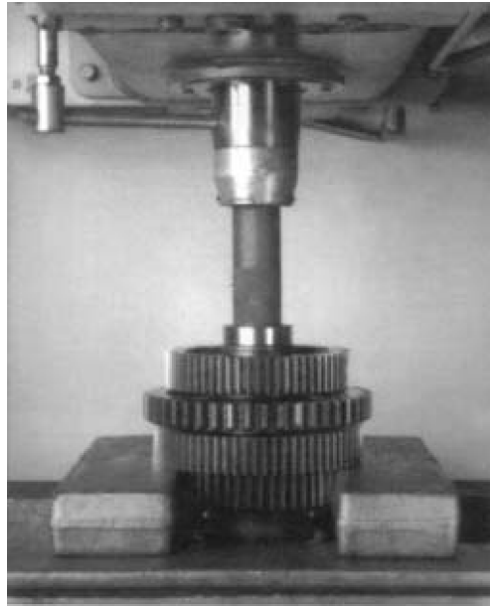

3. Position the countershaft in the press as shown. Press the next two gears from the shaft.

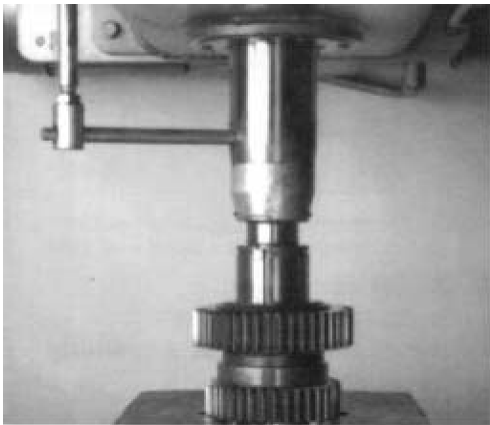

Bench Service Procedure

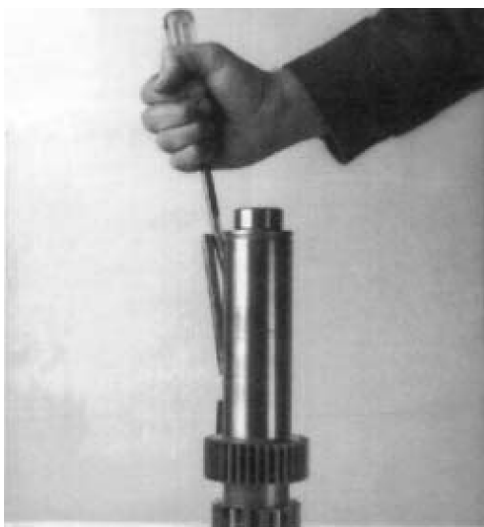

4. Inspect the keys and roll pin. Remove and replace if damaged.

How to Disassemble the Auxiliary Drive Gear Assembly

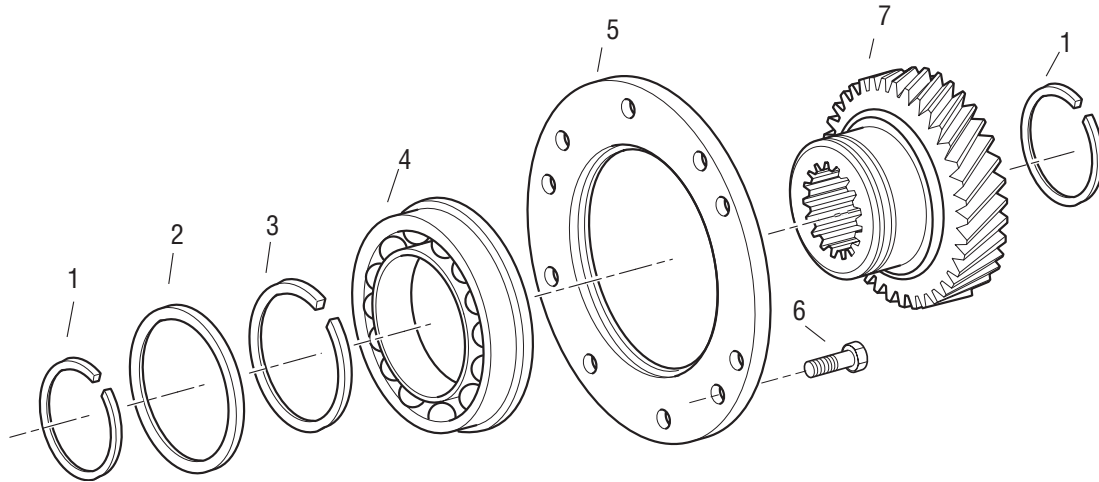

1 - Snap Ring

2 - Retainer

3 - Snap Ring

4 - Bearing

5 - Retainer

6 - Capscrew

7 - Auxiliary Drive Gear

Procedure -

1. If so equipped, remove the snap ring retainer with two screwdrivers.
2. Remove the snap ring from the auxiliary drive gear hub.
3. Use a press, if necessary, to remove the gear from the bearing.

Bench Service Procedure

How to Prepare the Main Case for Assembly

Thoroughly clean case of metal particles. Remove the gasket material from flange surfaces. Inspect flange surfaces for damage. Inspect bearing bores for damage or excessive wear. Replace as necessary.

If necessary, replace any damaged or worn clutch housing or rear support studs. Apply Eaton® Fuller® thread sealant #71205 or equivalent to any replacement studs before installing them.

Verify the three magnetic discs are firmly attached to the bottom of the main case. If they are not firmly attached, apply 3M scotch grip or equivalent adhesive to the bottom of the discs and attach them to the main case.

How to Assemble the Auxiliary Drive Gear Assembly

Special Instructions

Inspect the O-rings and replace if damaged.

Apply Eaton Lubricant #71214 or equivalent to the auxiliary drive gear O-rings.

Because the auxiliary drive gear assembly is used in checking reverse gear axial clearances and centering mainshaft in rear bearing bore during assembly of the mainshaft assembly, it is necessary to complete the following procedure BEFORE assembling the mainshaft assembly.

Special Tools

See "Tool Information."

Item T10: A flanged-end driver and maul

Procedure -

1. If previously removed, install the O-rings on extended front hub of auxiliary drive gear.
2. Install the retainer ring on auxiliary drive gear, snap ring groove facing front hub and away from gear teeth.

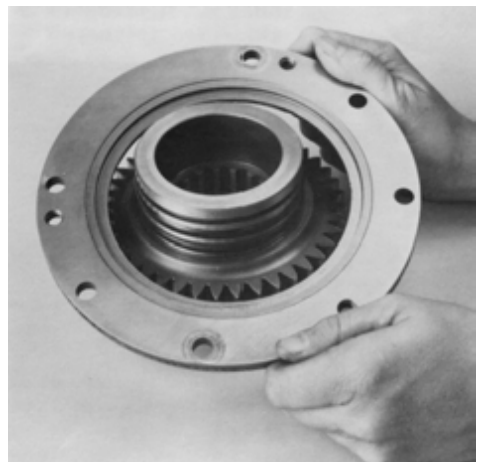

Bench Service Procedure



3. Start the auxiliary drive gear bearing on front hub, bearing snap ring facing groove in retainer ring. Using both the inner and outer race of bearing as a base, press the bearing on gear with snap ring in groove of retainer ring or use a bearing driver.



4. Install the snap ring in groove of front gear hub to retain bearing.

How to Assemble the Lower Reverse Idler Gear Assembly

Special Instructions

The new reverse idler shaft uses a snap ring in place of the capscrew.

Special Tools

- Torque Wrench 100 lb. ft. capacity
- Previous Design

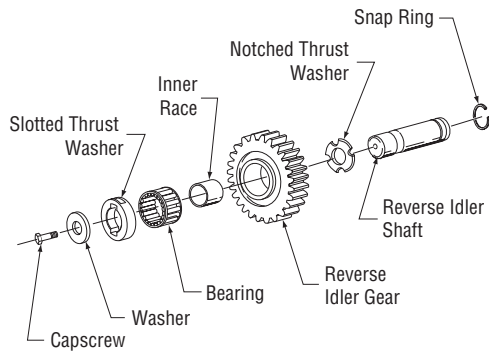

Current Design

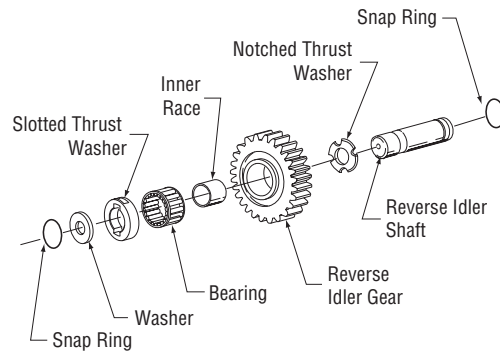

Procedure -

1. Position the reverse idler bearing and inner race into the reverse idler gear.
2. Hold the reverse idler gear and flat thrust washer in place in the main case, and insert the idler shaft, threaded end to the front, through the rear case bore and into the gear. Do not insert the reverse idler shaft into the main case support boss yet.
3. Position the slotted thrust washer in front of the gear with a slot facing up. Note the word FRONT on the slotted washer, and make sure it faces the front of the transmission. Continue to feed the idler shaft forward through this washer and into the hole in the case boss.
4. Slide the reverse idler shaft into the support boss bore, and with a soft bar and driver, drive the reverse idler shaft fully into position.

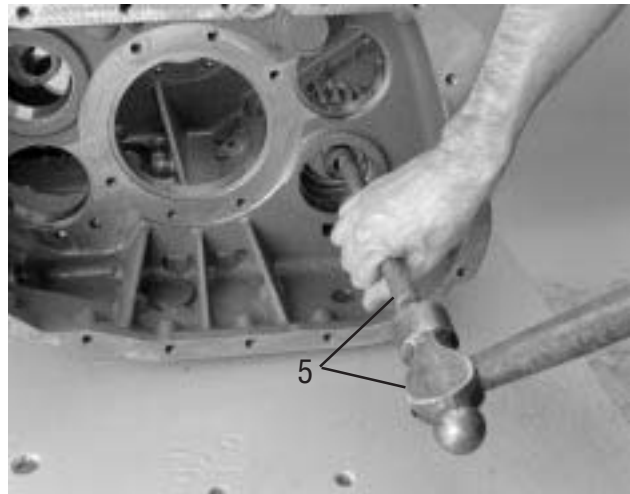

Bench Service Procedure

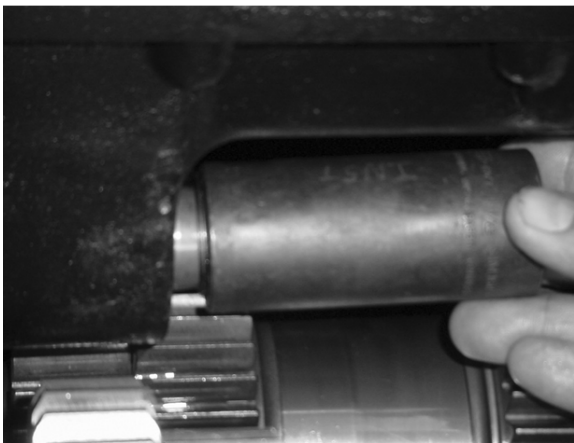
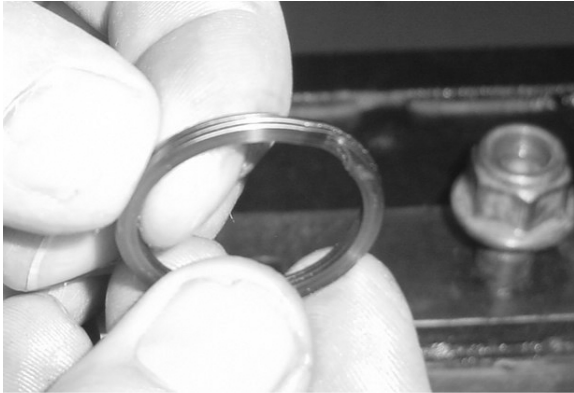

5. Secure the shaft in position according to one of the procedures below:

Note: For Nut Fastener Design: Inspect the nylon locking insert in the nut, and replace the nut if it is excessively worn. After inspecting and/or replacing the nut, install the nut and washer on shaft front. Tighten the nut to 67-75 lb. ft. (90 to 101 N•m) of torque.

Note: For Capscrew Fastener Design: Apply Eaton®Fuller® thread sealant #71205 or equivalent to the capscrew threads, and install the capscrew and washer. Tighten the capscrew to 67-75 lb. ft. (90 to 101 N•m) of torque.

Note: For Snap-ring design: Install the washer and snap ring on the idler shaft using a 1-1/8" (29 mm) socket. Push the snap ring over the tapered end of the shaft until fully seated in groove.

How to Assemble the Mainshaft Assembly with Low Force Gearing

Special Instructions

The design of the mainshaft with Low Force Gearing is slightly different from the standard mainshaft. It still utilizes Non-Selective (Non-Adjustable) Tolerance Washers, but the 1st and reverse gears and sliding clutch have been redesigned. In this configuration, the 1st/reverse sliding clutch rides on a clutch hub and the 1st and reverse gears have been redesigned to accommodate this change.

The proper mainshaft key must always be used with the proper design mainshaft washers. If necessary, refer to the parts manual for your specific model to confirm the proper parts.

Special Tools

- A piece of 5/32" air line, 1" long
- Vise with brass jaws

Procedure -

1. With mainshaft pilot-end down, secure the mainshaft in a vise equipped with brass jaws or wood blocks.
2. If previously removed, install the roll pin in keyway.



3. With mainshaft pilot-end down, install offset washer (flat surface up). Rotate the washer until the washer splines and mainshaft splines align.
4. Start at the mainshaft bottom and install a plastic line in the marked keyway to lock the washer in place.



5. With clutching teeth down, position the 4th gear on the mainshaft.
6. Install the flat washer. Rotate the washer until the washer splines and mainshaft splines align.



Transmission Overhaul Procedures-Bench Service



7. With clutching teeth up and against the spacer, install the 3rd gear.



8. Position the offset washer (flat surface down) against the gear. Rotate the washer until the washer splines and mainshaft splines align.



9. Push the air line up to lock the washers on the mainshaft.

10. With the missing internal splines aligned with the plastic line, install the proper sliding clutch.



11. Position the next offset washer in the next available groove. Rotate the washer until the washer splines and mainshaft splines align.

12. Push the air line up to lock the washer on the mainshaft.

13. With clutching teeth down, position the 2nd gear on the mainshaft.

14. Position the flat washer against the gear. Rotate the washer until the washer splines and mainshaft splines align.

Transmission Overhaul Procedures-Bench Service

15. With clutching teeth up, install the 1st gear on the shaft against previously installed gear.



16. Position the offset washer (flat surface down) against the gear. Rotate the washer until the washer splines and mainshaft splines align.
17. From the mainshaft rear, install the mainshaft key into the spline with the air line. Pull the air line from the spline while installing the key.



18. Install the snap ring in the mainshaft groove.
19. Install the 1st/reverse sliding clutch.



20. Install the clutch hub with the bezel facing up.
21. Install the reverse gear.
22. Remove the mainshaft from the vise and lay on its side. Install the front sliding clutch into position.

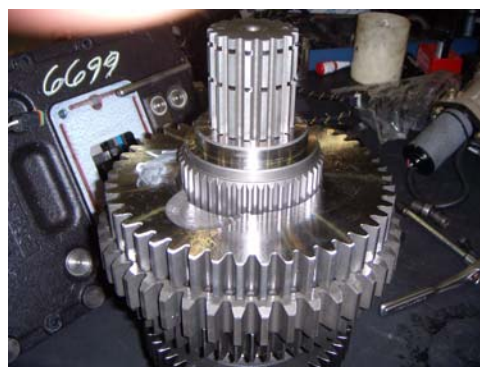

Bench Service Procedure

How to Assemble the Countershaft Assemblies

Special Instructions

Except for the PTO gears, the upper and lower countershaft assemblies are the same. To avoid confusion during installation, mark the upper countershaft (45-tooth PTO gear) with an "U". The lower countershaft has a 47-tooth PTO gear.

Special Tools

Snap ring pliers

Press

Procedure -

1. If previously removed, install the keys in each countershaft keyway.
2. Align smallest diameter gear keyway with the countershaft key, long hub to countershaft front, and press the gear on the countershaft.



Bench Service Procedure

3. Align 2nd smallest diameter gear keyway with the countershaft key, long hub against 1st speed gear, and press the gear on the countershaft.



4. Align 3rd smallest diameter gear keyway with the countershaft key, long hub to countershaft front, and press the gear on the countershaft.



Bench Service Procedure



5. Align PTO gear keyway with the countershaft key, bullet-nose of teeth facing up (shaft rear). Align drive gear keyway with the countershaft key, long hub against PTO gear, and press both gears on the countershaft.



6. On each countershaft front, install the drive gear retaining snap ring in groove.



7. Use a flanged-driver or the press to install the bearing inner race on the countershaft front against the drive gear.

Note: Make sure all gears are pressed into place.

Note: Make sure the bearing inner race is installed.

How to Install the Auxiliary Countershaft Assembly

Special Instructions

To make auxiliary section assembly easier, you can make an auxiliary section fixture out of a 2" x 12" piece of wood.

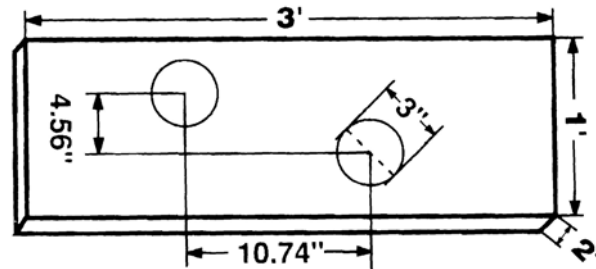

This fixture is designed to ease the assembly of the auxiliary gearing. Set the auxiliary countershaft rear bearings in the 3" holes. Set the assembled auxiliary mainshaft between the countershafts with the timing marks aligned.

Special Tools

Auxiliary countershaft retaining straps

Toolmaker's dye

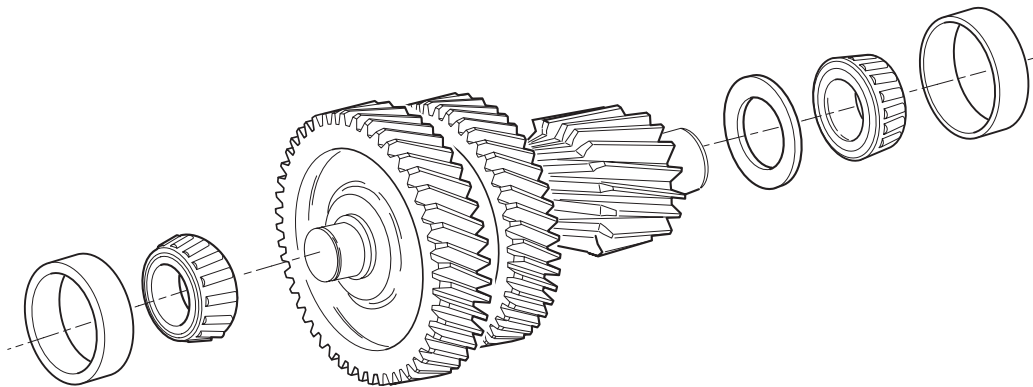

Procedure -

1. Place the countershaft assembly vertical on a clean, flat surface. If previously removed, use the proper driver and maul to install the countershaft bearings.
2. Mark each countershaft for correct timing. Locate the "O's" stamped on the countershaft and mark the teeth with highly visible toolmaker's dye or paint.



Bench Service Procedure



3. Place the countershafts in the fixture or on a flat surface for reassembly. Turn the countershafts so that the two teeth marked on each LO range gear are towards the middle.



4. Align the output shaft between the countershafts, match the timing marks.



5. With range yoke offset side facing down, install into the synchronizer sliding slot.

6. Place the auxiliary housing over the countershaft assemblies and the output shaft assembly.



7. Make sure the output shaft bearing spacer is on the output shaft.
8. Heat the rear output bearing cone and install the bearing, tapered side down, on the shaft.
9. Position a new gasket on the rear bearing cover mounting surface.

Bench Service Procedure

10. Position the rear bearing cover.
11. Apply Eaton/Fuller Sealant #71205 or equivalent to the retaining capscrews.
12. Install the six (6) retaining capscrews in the non-chamfered hole, tighten to 35-45 lbs. ft. of torque.



13. Install the bearing races.



14. Install each auxiliary countershaft retaining strap with 2 - 3/8" NC x 1" and 1 - 3/8" NC x 2 1/2" clean capscrews.

Note: Do not use an air gun. Tighten by hand until the capscrews are snug.



Bench Service Procedure

How to Install the Lower Countershaft Bearings

Special Instructions

The lower reverse idler assembly should be installed before the lower countershaft.

The front bearing inner race must be pressed on the countershaft front.

The flanged-end driver must cover the bearing outer race for proper installation.

Special Tools

See "Tool Information."

Item T7: Flanged-end bearing driver

Item T8: Bearing driver

Item T9: Countershaft support tool



Procedure -

1. Move the countershaft to the rear and insert the countershaft support tool to center shaft in rear case bore.
2. Obtain a spare inner countershaft race.

Bench Service Procedure

3. Temporarily install the spare countershaft inner race inside the front roller bearing for installation.



4. Use a flanged-end driver to start the front bearing in case bore.
5. Use a screwdriver inserted in the countershaft capscrew bore to help center the countershaft.
6. Move the countershaft forward into the bearing.
7. Use a flanged-end bearing driver and maul to completely seat the front bearing in the case bore.



Note: Make sure to contact only the bearing and not the temporary race with the driver. The temporary race should fall out when installation is complete.

8. On the countershaft front, position the retainer plate with roll pin in hole at shaft end.
9. Install the front bearing retainer plate and capscrew. If the capscrew is being reused, apply Eaton Fuller thread sealant #71205 or equivalent. Torque the capscrew to 90-120 lbs. ft.



Note: Earlier models may have a roll pin in the retainer. This roll pin is not required and was removed on units built after 1994.

Bench Service Procedure

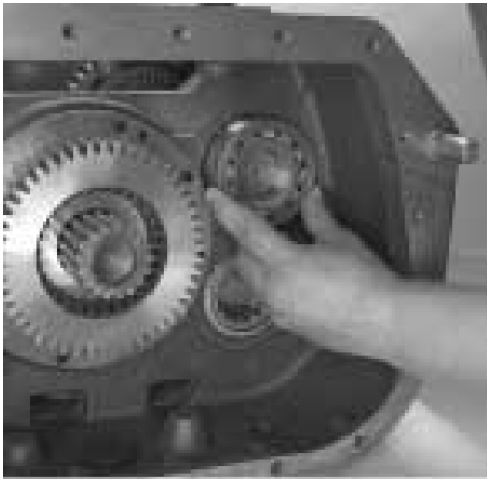

10. From the rear, remove the countershaft support tool.

11. Install the rear countershaft bearing. Position the bearing so that the larger chamfer on the bearing inside diameter is installed towards the shaft. Use a bearing driver that contacts both the bearing inner race and outer race.

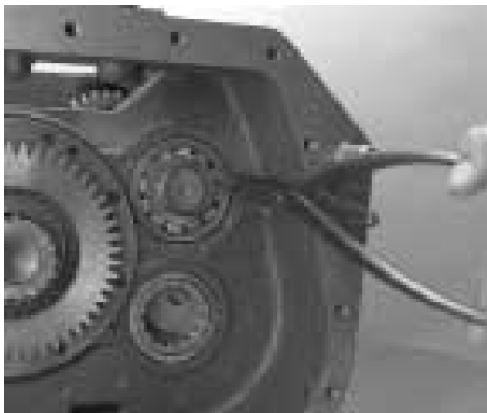

12. In the countershaft rear groove, install the rear snap ring.

Note: Make sure the front bearing capscrew is properly torqued.

Note: Make sure the rear snap ring is in place.

How to Install the Input Shaft and Main Drive Gear

Special Instructions

None

Special Tools

See "Tool Information."

Item T10: Input bearing driver

Toolmaker's dye

Procedure -

1. Use a highly visible toolmaker's dye and mark the main drive gear for timing purposes. To mark the gear, paint toolmaker's dye on any two adjacent teeth, and then paint the two adjacent teeth directly opposite the first two teeth.
2. If necessary, install the bushing in the back of the input shaft.
3. Temporarily position the upper countershaft up and away from the transmission center.
4. From inside the case, mesh the lower countershaft drive gear marked tooth with either set of main drive gear marked teeth.
5. From the front, engage the input shaft spline teeth into the main drive gear.

Note: The current design input shaft spline teeth have noticeable clearance to the main drive gear internal spline teeth. This is normal.

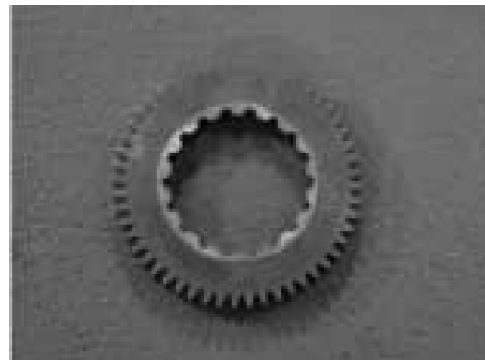

Bench Service Procedure

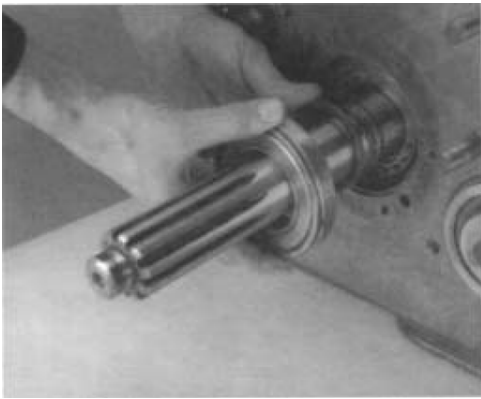

6. Install the snap ring in the main drive gear inside groove.
7. Install the spacer washer over the input shaft. With the bearing external snap ring to the outside, position the bearing on the input shaft.

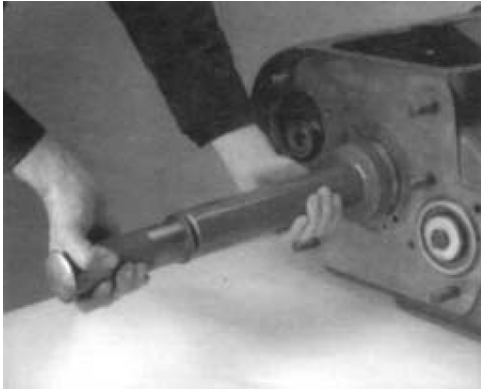

8. Install the input shaft bearing over the input shaft. Use a flanged-end bearing driver which contacts both the bearing inner race and outer race. Drive the bearing until it contacts the front case.
9. Temporarily install the front bearing cover with two cap-screws.
10. From inside the main case, drive the input shaft forward until it is fully seated.



11. Install the input shaft retaining snap ring.
Note: Do not replace the small rubber lip seal. It is used only to prevent leakage during shipping.
12. Do not reinstall the input bearing cover at this time. Instead, pull the input shaft and bearing forward to allow for main-shaft installation.

Mainshaft Assembly

There are three distinct mainshaft washer and mainshaft key designs. They are (listed from oldest design to newest design):

- Six (6) sided mainshaft key with selective (adjustable) thickness tolerance washers.
- Three (3) sided mainshaft key with selective (adjustable) thickness tolerance washers.
- Three (3) sided mainshaft key with non-selective (non-adjustable) tolerance washers.

Note: Between 1993 and 1996, some models were produced with a mixture of selective thickness washers and non-selective tolerance washers on the same mainshaft.

The proper mainshaft key must always be used with the proper design mainshaft washers. If necessary, refer to the parts manual for your specific model to confirm the proper parts.

Previous design levels can be updated to the current design.

Bench Service Procedure

How to Install the Mainshaft Assembly with Selective (Adjustable) Thickness Tolerance Washers

Special Instructions

Each mainshaft gear must have its inside snap ring installed before placement on the mainshaft. Do not install reverse gear inside snap ring at this time.

Gear tolerance washers are internally splined and locked to the mainshaft by the key. Gear spacers are externally splined to engage with gear hub clutching teeth. There is one tolerance washer and one spacer for each mainshaft gear.

Axial clearance (end-play) limits are .006"-.015" for all mainshaft gears.

If the axial clearance is less than the minimum .006" tolerance, the tolerance washer should be replaced with a thinner tolerance washer. This will increase the axial clearance between the gears. If the axial clearance is greater than the maximum .015" tolerance, a thicker tolerance washer should be installed. This will decrease the axial clearance between the gears.

If necessary, refer to the parts manual for your specific transmission model to determine the correct position of each mainshaft gear.

The mainshaft you are using may have 3 grooves in certain gear positions. The middle groove is not used with the selective washer design.

Selective Mainshaft Washers

Use the following chart to specify and order Washers. Washers are required to set correct tolerance or end-play between mainshaft gears. A set of five selective Washers is required for proper mainshaft assembly.

Do not mix Key and Washer designs. Always match Washers with appropriate Key shape.

6-Sided Key

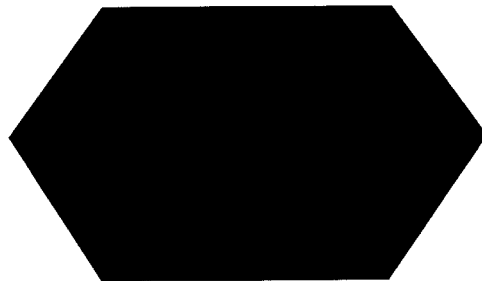

3-Sided Key

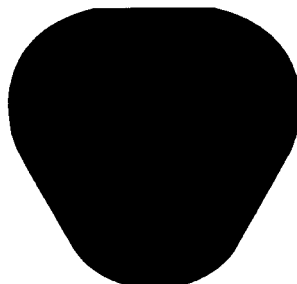

Bench Service Procedure

Selective Mainshaft Washers Table

Current Part	Size	Color Code
4300830	.244	Blue - Light Blue
4300382	.249	White - Light Blue
4300383	.254	Green - Light Blue
4300384	.259	Orange - Light Blue
4300385	.264	Purple - Light Blue
4300386	.269	Yellow - Light Blue
4300387	.274	Black - Light Blue

Current Part	Size	Color Code
14711	.248 - .250	White
14712	.253 - .255	Green
14713	.258 - .260	Orange
14714	.263 - .265	Purple
14715	.268 - .270	Yellow
14716	.273 - .275	Black

Washers for 6-Sided Key - OBSOLETE

These Washers are not available - Part # and Color are Listed Here for Reference Only. These Washers are replaced by Washers for Hex Key shown above - Replaced By #'s are indicated.

Obsolete	Current Part	Color Code
18701	14711	White - Red
18702	14712	Green - Red
18703	14713	Orange - Red
18704	14714	Purple - Red
18705	14715	Yellow - Red
18706	14716	Black - Red

Bench Service Procedure

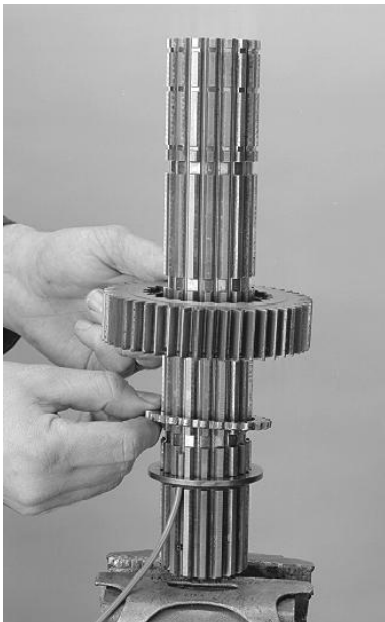
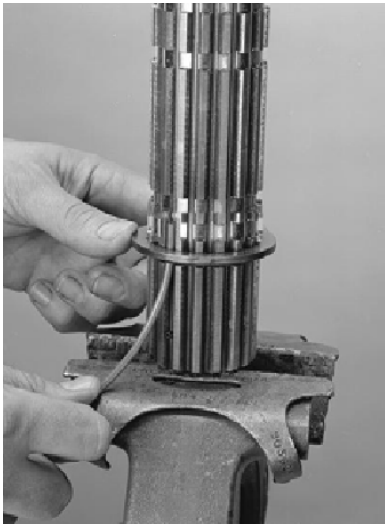

Procedure -

1. With mainshaft pilot-end down, secure the mainshaft in a vise equipped with brass jaws or wood blocks.
2. If previously removed, install the roll pin in keyway.
3. With the washer flat side up, position a gear tolerance washer (white) in the mainshaft 1st or bottom groove. Rotate the washer until the washer splines and mainshaft splines align.
4. Start at the mainshaft bottom and install a 1/8" or 5/32" diameter plastic line in the keyway to lock the washer in place. As limit washers and gears are installed, continue to push the plastic line up.
5. Against the 4th speed gear washer, position a spacer washer against the tolerance washer.
6. With clutching teeth down and engaged with the spacer external splines, position the proper gear on the mainshaft. If necessary, refer to the illustrated parts list to determine gear order.

7. With clutching teeth up and against this gear, install the next and spacer washer.

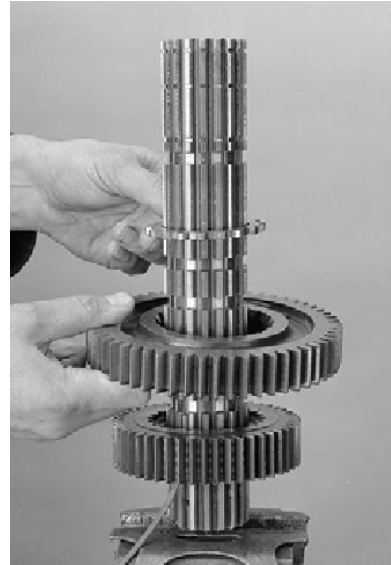

8. With the washer flat side down, position a tolerance washer against the spacer. Rotate the washer until the washer splines and mainshaft splines align.
9. Push the air line up to lock the washer on the mainshaft.



10. Insert two large screwdrivers between the two gears. Apply slight downward pressure to spread gear evenly. Between the gear hub and mainshaft spacer, insert .006" feeler gauge and .015" feeler gauge. If out of tolerance, change the washer against the mainshaft spacer. Refer to information before stepped procedures for further information.
11. With the missing internal splines aligned with the plastic line, install a sliding clutch.
12. With the washer flat side up, position tolerance washer (white) in the next available groove. Rotate the washer until the washer splines and mainshaft splines align.



Bench Service Procedure



13. Push the air line up to lock the washer on the mainshaft.



14. Install a gear spacer.

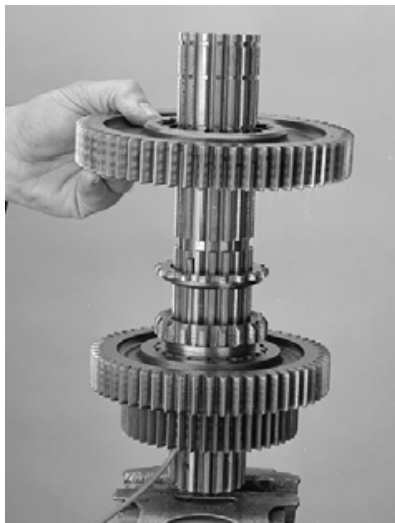

15. With clutching teeth down, position the next gear on the mainshaft engaging with spacer external splines.

16. With clutching teeth up, install the next gear on shaft against the previously positioned gear.
17. Position another spacer against the previously positioned gear, engaging the spacer external splines with gear clutching teeth.



18. With washer flat side down, position the tolerance washer against the spacer. Rotate the washer until the washer splines and mainshaft splines align.
19. Push the air line up to lock the washer on the mainshaft.



20. Insert two large screwdrivers between the two gears. Apply slight downward pressure to spread the gears evenly. Between the gear hub and mainshaft spacer, insert .006" feeler gauge and .015" feeler gauge. If out of tolerance, change the washer against the mainshaft spacer. Refer to information before stepped procedures for further information.
21. Align the sliding clutch missing internal spline with the mainshaft key and install the reverse speed sliding clutch.
22. With the flat side up, place a washer (blue or white) in the next available groove. Rotate the washer until the washer splines and mainshaft splines align.

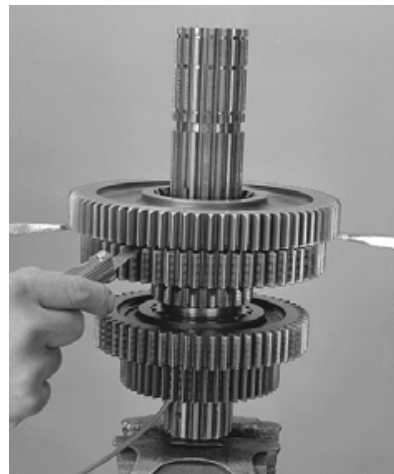

Bench Service Procedure



23. Push the air line up to lock the washer on the mainshaft.
24. Against the tolerance washer, position reverse speed gear spacer.

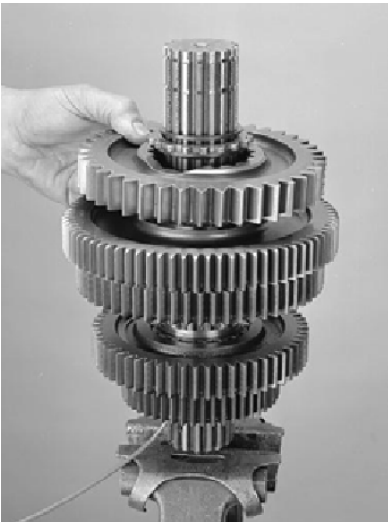

25. Install reverse gear on the mainshaft. Engage the gear clutching teeth with spacer external splines and sliding clutch. Move the reverse gear down against the 1st speed gear.



26. At this time remove the air line and insert the mainshaft key. Be careful not to move the gears while doing this procedure, the tolerance washers are unlocked and can rotate, which would cause the gears to drop.

27. Some models use a flat key at the front. Install the spline washer that is retained by this key, then insert this key.

28. Remove the mainshaft from the vise.

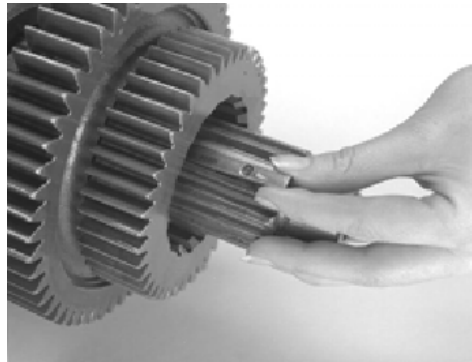

29. On the shaft front, align the sliding clutch missing internal spline with the mainshaft key and install the front sliding clutch. Engage the sliding clutch external splines with the gear clutching teeth.

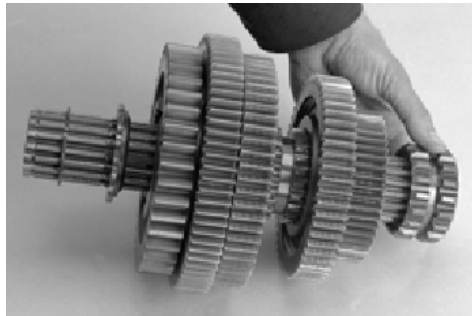

Bench Service Procedure

How to Install the Mainshaft

Special Tools

See "Tool Information."

Item T15: Mainshaft hook

A piece of rope

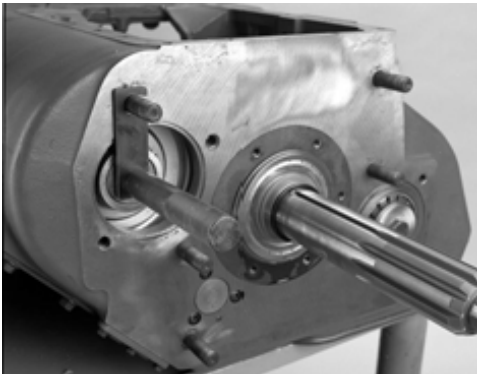

Procedure -

1. Secure the upper countershaft up and away from the transmission center.

TIP: A large screwdriver or prybar can be inserted between the main drive gear and countershaft, as shown.

2. Hold the reverse gear against the next gear, and lower the mainshaft assembly into position while guiding the shaft rear through the case bore. A mainshaft hook or piece of rope can be used to hold on to the mainshaft.

Bench Service Procedure

3. Move the mainshaft forward to position the mainshaft pilot end into the input shaft rear.



4. The reverse idler gear will not be fully installed at this time.

Note: Install the reverse idler bearing and inner race into the reverse idler gear. Place the gear in its approximate location. The gear's long hub is positioned forward.

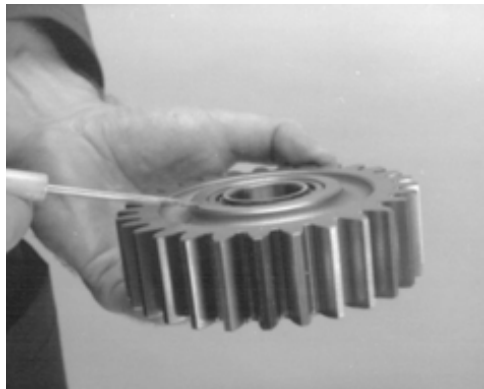

5. Slide the mainshaft reverse gear rearward.

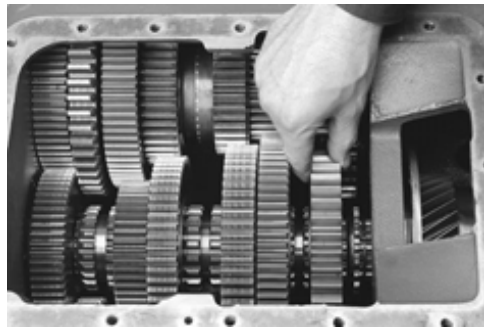

6. While holding the mainshaft reverse gear rearward, install the snap ring into the reverse gear.
7. To temporarily hold the mainshaft rear in position, slide the auxiliary drive gear assembly over the mainshaft rear and into the case bore. Do not complete installation of the auxiliary drive at this time.

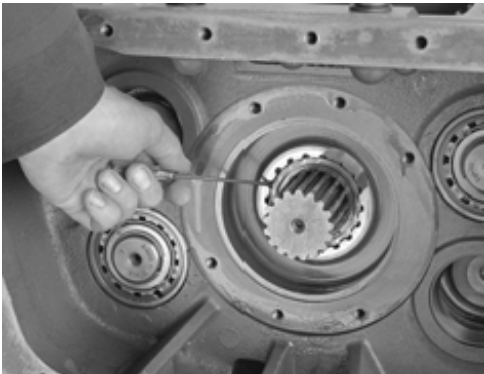

Bench Service Procedure

How to Install the Upper Countershaft Bearings

Special Instructions

The front bearing inner race must be pressed on the countershaft front.

The flanged-end driver must cover the bearing outer race for proper installation.

Temporarily use the assembled auxiliary drive gear to hold the mainshaft in the input shaft pilot.



The upper countershaft bearings must be installed after the installation of the mainshaft.

Special Tools

See Tool Information.

Item T7: Flanged-end bearing driver

Item T8: Bearing driver

Item T9: Countershaft support tool

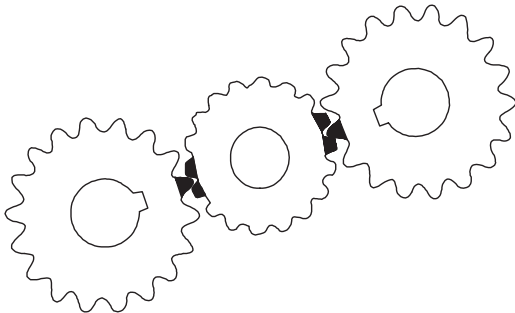

Procedure -

1. Make sure the lower countershaft and main drive gear timing marks are aligned.
2. Mesh the upper countershaft marked tooth with the two remaining main drive gear marked teeth.
3. Move the countershaft to the rear and insert the counter-

shaft support tool to center shaft in rear case bore.



4. Obtain a spare inner countershaft race.



5. Temporarily install a spare countershaft inner race inside the front roller bearing for installation.



6. Use a flanged-end driver to start the front bearing in case bore.
7. Use a screwdriver inserted in the countershaft capscrew bore to help center the countershaft.
8. Move the countershaft forward into the bearing.
9. Use a flanged-end bearing driver and maul to completely seat the front bearing in the case bore.

Note: Make sure to contact only the bearing and not the temporary race with the driver. The temporary race should fall out when installation is complete.

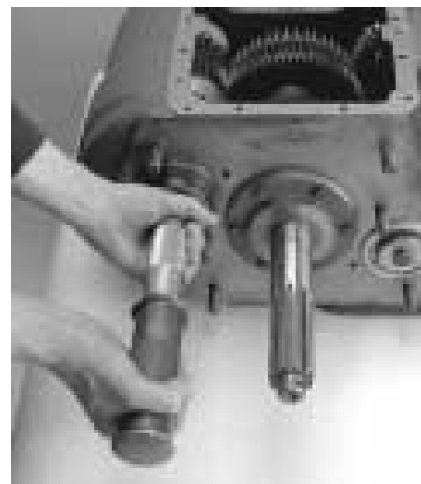

Bench Service Procedure

10. On the countershaft front, position the retainer plate with roll pin in hole at shaft end.



11. Install the front bearing retainer plate and capscrew. If the capscrew is being reused, apply Eaton Fuller thread sealant #71205 or equivalent. Torque the capscrew to 90-120 lbs. ft.

Note: Earlier models may have a roll pin in the retainer. This roll pin is not required and was removed on units built after 1994.



12. From the rear, remove the countershaft support tool.
13. Install the rear countershaft bearing. Position the bearing so that the larger chamfer on the bearing inside diameter is installed towards the shaft. Use a bearing driver that contacts both the bearing inner race and outer race.

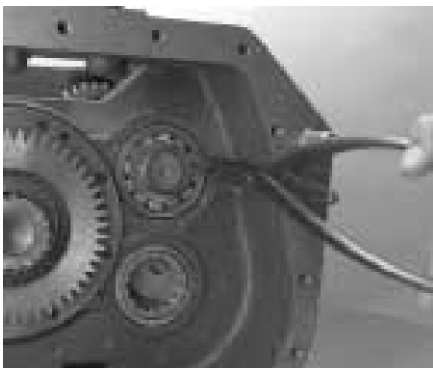

14. In the countershaft rear groove, install the rear snap ring.

Note: Make sure the front bearing capscrew is properly torqued.

Note: Make sure the rear snap ring is in place.

How to Install the Upper Reverse Idler Gear Assembly

Special Instructions

The installation procedure is the same as that for the lower reverse idler shaft.

The new reverse idler shaft uses a snap-ring in place of the capscrew.

Previous Design

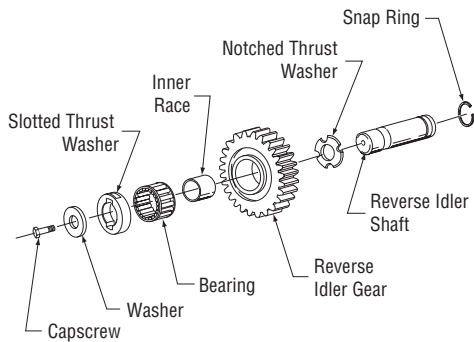

Current Design

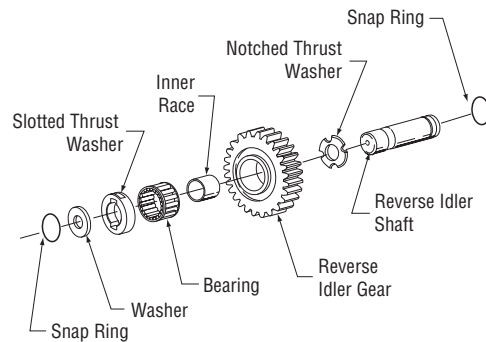

Special Tools

- Typical service tools

Procedure -

1. Lift the mainshaft reverse gear to allow the reverse idler gear to drop into mesh and into the proper position.
2. Place and hold the idler flat thrust washer at the back of the gear.
3. While holding the gear and washer in position, feed the reverse idler shaft through the flat thrust washer and gear.
4. Position the slotted thrust washer in front of the reverse idler gear with one of the slots facing up, and continue to feed the idler shaft forward. Make sure the word FRONT faces the front of the main case.
5. With a soft bar and driver, drive the reverse idler shaft fully into position.

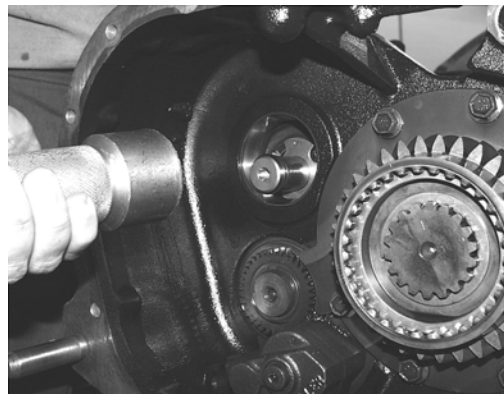

Bench Service Procedure

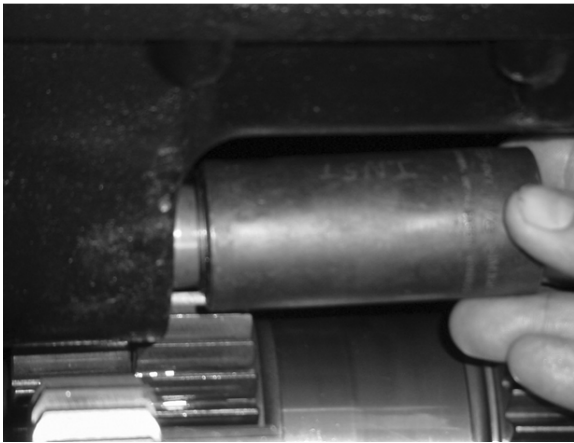
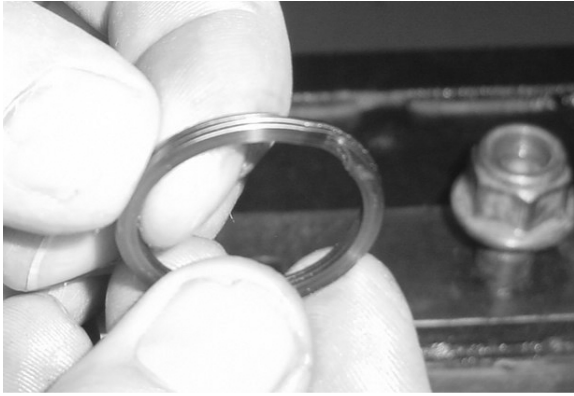

6. Secure the shaft in position according to one of the procedures below:

Note: For Nut Fastener Design: Inspect the nylon locking insert in the nut, and replace the nut if it is excessively worn. After inspecting and/or replacing the nut, install the nut and washer on shaft front. Tighten the nut to 67-75 lb. ft. (90-101 N•m) of torque.

Note: For Capscrew Fastener Design: Apply Eaton®Fuller® thread sealant #71205 or equivalent to the capscrew threads, and install the capscrew and washer. Torque the capscrews to 67-75 lb. ft. (90-101 N•m).

Note: For Snap-ring design: Install the washer and snap ring on the idler shaft using a 1-1/8" (29 mm) socket. Push the snap ring over the tapered end of the shaft until fully seated in groove.

How to Install the Standard Torque Auxiliary Drive Gear Assembly

Procedure -

1. Install the auxiliary drive gear assembly on the mainshaft rear. Use a flanged-end driver to fully seat the assembly in the case bore.
2. Apply Eaton® Fuller® thread sealant #71205 or equivalent to the capscrew threads, and install the six (6) capscrews. Torque the capscrews to 35-45 lbs. ft.

Note: On some previous designs, lock wire was used on the capscrews, lock wire as needed.

3. Install the snap ring in the mainshaft groove rear. The mainshaft may need to slide rearward.

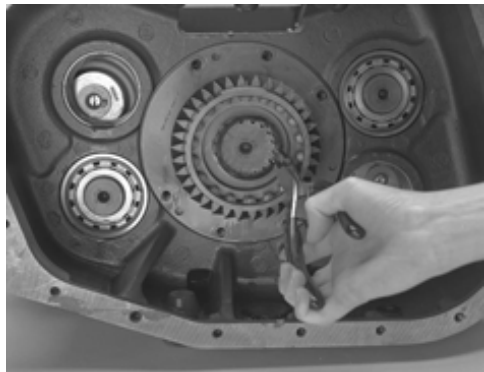
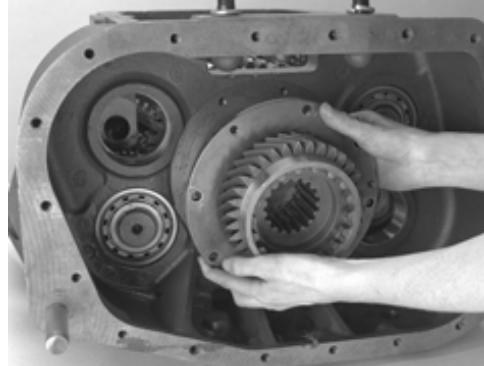

Bench Service Procedure

How to Install the Auxiliary Section With Tapered Bearings

Special Instructions

There are different capscrew lengths, install in the correct location.

Auxiliary sections can be installed either with the transmission in the horizontal position or the vertical position.

To install in the vertical position, the clutch housing must be installed.

Special Tools

See Tool Information.

Item T2: Auxiliary section hanger bracket for horizontal removal

A steel bar longer than the width of the output yoke for vertical removal

A hoist with a lifting chain

Procedure - To install the auxiliary section in the horizontal position.

1. Position a new gasket on the transmission mounting surface.
2. Attach an auxiliary section hanger bracket to the auxiliary section top.
3. Attach a lifting chain to the auxiliary section hanger bracket.
4. Position the auxiliary section on the two (2) dowel pins.
5. Slide the auxiliary section on until the hanger bracket contacts the front section back.
6. Remove the auxiliary section hanger bracket.
7. Slide the auxiliary section the rest of the way into position.
8. Apply Eaton/Fuller Sealant #71205 or equivalent to the retaining capscrews.

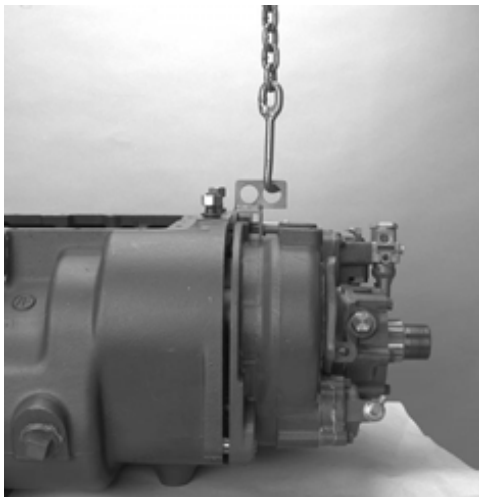

Bench Service Procedure

9. Install the retaining capscrews, tighten to 35-45 lbs. ft. of torque.
10. To finish installation, see See “Shim Procedure With A Shim Tool For Tapered Bearings” on page 168..



Procedure - To install the auxiliary section in the vertical position.

11. With blocks under the clutch housing to prevent input shaft damage, place the transmission in the vertical position, clutch housing down.
12. Position a new gasket on the transmission mounting surface.
13. Install a steel bar through the yoke.
14. Attach a lifting chain to the steel bar.
15. Position the auxiliary section over the two (2) dowel pins.
16. Slide the auxiliary section down the dowels.
17. Apply Eaton/Fuller Sealant #71205 or equivalent to the retaining capscrews.



Bench Service Procedure

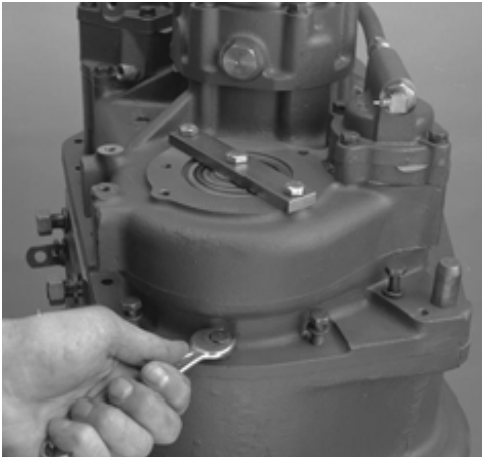

18. Install the retaining capscrews, tighten to 35-45 lbs. ft. of torque.
19. Remove the steel bar and chain.
20. To finish installation, see See “Shim Procedure With A Shim Tool For Tapered Bearings” on page 168..

Shim Procedure With A Shim Tool For Tapered Bearings

Special Instructions

If you are not using a shim tool, go to the procedure "Shim Procedure Without a Shim Tool for Tapered Bearings."

CAUTION

Use genuine Eaton® replacement gaskets for the auxiliary housing and countershaft bearing cover. Do not omit the gaskets. Bearing endplay is influenced by the compressed thickness of the gasket (.011-.012" or .28-.30 mm).

The bearing endplay must be checked and adjusted any time a countershaft, bearing, or housing is replaced. If, during reassembly, the same countershaft, bearings, housing, and shims are reused and kept in the same location, it is not necessary to reset bearing endplay.

The following procedure is used to adjust the endplay for the auxiliary countershaft tapered bearings. By correctly following this procedure, each countershaft will have .001"-.005" (.03-.12 mm) endplay.

Special Tools

See "Tool Information."

Item T3: Shim tool

Procedure -

1. The auxiliary countershaft bearing covers and shims should be removed. Make sure all old gasket material is cleaned from the gasket mounting surfaces on the countershaft bearing covers and the auxiliary housing.
2. Verify that the auxiliary section is in gear. When the output shaft is rotated, the countershafts must also rotate. If not, shift the auxiliary into gear by applying shop air to the high range air port on range cylinder to shift into gear.
3. Clean and lightly oil the threads of two countershaft bearing cover capscrews. Thread these capscrews into two opposing capscrew holes in the housing. They must thread in easily. If necessary, run a 3/8"-16 tap into the holes to clean the threads.
4. Install the .100" shim tool and evenly thread in the two

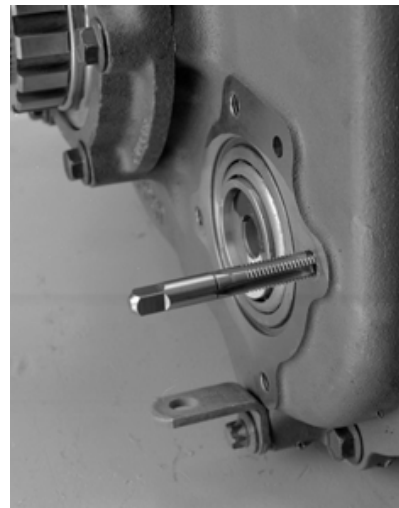

Bench Service Procedure

cleaned capscrews. Do not install the gasket at this time.



- Evenly tighten the two capscrews to 7 lbs. in. (inch-pounds). The gap between the shim tool and the housing surface should be even from side to side.

Note: 7 lbs. in. is slightly more than finger tight. Do not overtighten the capscrews. If the capscrews are too tight, the shim tool will warp.

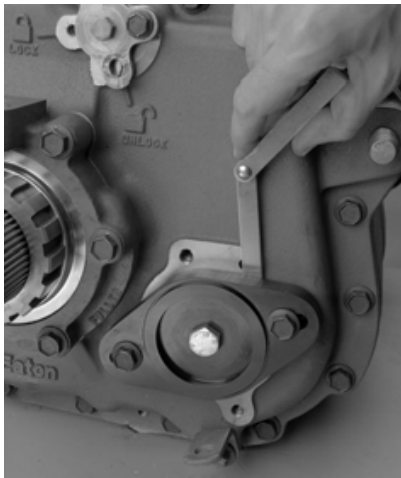

- Rotate the output shaft 4 times clockwise and 4 times counterclockwise. The rotation will seat and align the rollers in each tapered bearing. Re-torque the capscrews to 7 lbs. in. If the countershafts do not rotate, the range sliding clutch is in neutral. Shift the range clutch to either high or low range.
- Use a feeler gauge to measure the gap between the shim tool and the auxiliary housing gasket surface. Measure and record the gap at both capscrew locations.

Gap 1 = .060"; Gap 2 = .050"
Total Gap: .060" + .050" = .110"
Average: .110"/2 = .055"
Select yellow shim as indicated in the shim chart at the end of this section.

- Average the two feeler gauge measurements by adding the measurements together and dividing by 2 as shown in Example 1.
- Locate the feeler gauge average measurement in the shim chart at the end of this section to determine the required shim and color code.

Note: The oil pump shim is used when an auxiliary oil pump or PTO is mounted on the countershaft. The oil pump shims have a smaller outside diameter.

Bench Service Procedure

10. Remove the shim tool.
11. Install the shim and place a new gasket around the auxiliary countershaft bore.
12. Apply Eaton® Fuller® thread sealant #71205 or equivalent to the auxiliary countershaft rear bearing cover capscrews and auxiliary countershaft rear bearing cover.
13. Install the auxiliary countershaft rear bearing cover and secure it with the capscrews. Make sure the shim is in proper location and is not pinched between the cover and the housing. Tighten the capscrews to 35-45 lbs. ft. (54-61 N•m).

TIP: Use a thick grease to hold the shim in position when installing the cover.

14. Repeat this procedure for the remaining countershaft.

Feeler Gauge Average Gap	Shim Thickness	Standard Shim Part Number	Oil Pump Shim Part Number	Color Code
.072-.075	.033-.034	4302345	4302346	Gold
.69-.0715	.036-.037	21452	21472	Red
.066-.0685	.039-.040	21453	21473	Pink
.063-.0655	.042-.043	21454	21474	Brown
.060-.0625	.045-.046	21455	21475	Tan
.057-.0595	.048-.049	21456	21476	Orange
.054-.0565	.051-.052	21457	21477	Yellow
.051-.0535	.054-.055	21458	21478	Green
.048-.0505	.057-.058	21459	21479	Light Blue
.045-.0475	.060-.061	21460	21480	Lavender
.042-.0445	.063-.064	21461	21481	White
.039-.0415	.066-.067	21684	21686	Black
.036-.0385	.069-.070	21685	21687	Silver

Bench Service Procedure

Shim Procedure Without a Shim Tool for Tapered Bearings

Special Instructions

The shim procedure can be done in the horizontal or vertical position. The procedure is done the same.



Use genuine Eaton® replacement gaskets for the auxiliary housing and countershaft bearing cover. Do not omit the gaskets. Bearing endplay is influenced by the compressed thickness of the gasket (.011-.012" or .28-.30 mm).

The bearing endplay must be checked and adjusted any time a countershaft, bearing, or housing is replaced. If, during reassembly, the same countershaft, bearings, housing, and shims are reused and kept in the same location, it is not necessary to reset bearing endplay.

The following procedure is used to adjust the endplay for the auxiliary countershaft tapered bearings. By correctly following this procedure, each countershaft will have .001"-.005" (.03-.12 mm) endplay.

Shims must be aligned properly or else the rear bearing cover may be damaged when final torque is applied.

Special Tools

Typical service tools

Shims and Feeler gauge



Procedure -

1. The auxiliary countershaft bearing covers or countershaft straps and shims should be removed. Make sure all old gasket material is cleaned from the gasket mounting surfaces on the countershaft bearing covers and the auxiliary housing.
2. Verify that the auxiliary section is in gear. When the output shaft is rotated, the countershafts must also rotate. If not shift the auxiliary into gear by applying shop air to the high range air port on range cylinder to shift into gear.
3. Make sure a 0.100 countershaft rear bearing shim is installed. Be sure the countershaft rear bearing races are

seated in the bearing bores.

4. Install two (2) clean 3/8 " x 1" capscrews without washers directly across from each other in each bearing cover. Tapped holes in auxiliary case must be free of thread adhesive.



5. Evenly tighten the capscrews to 7 lbs. in. of torque. Do not install the countershaft rear bearing cover gasket. The gap between the bearing cover and the housing surface should be even from side to side.

Note: 7 lbs. in. is slightly more than finger tight. Do not overtighten the capscrews. If the capscrews are too tight, the bearing cover will become distorted.

6. Rotate the output shaft 4 times clockwise and 4 times counterclockwise. The rotation will seat and align the rollers in each tapered bearing. Re-torque the capscrews to 7lbs. in. If the countershafts do not rotate, the range sliding clutch or deep reduction sliding clutch is in neutral. Apply shop compressed air to shift cylinders to shift the sliding clutches into gear.



7. Use a feeler gauge, as close to each capscrew location as possible, and measure the gap between the countershaft rear bearing cover and the auxiliary housing gasket surface. Measure and record the gap at both capscrew locations.
8. Average the two feeler gauge measurements by adding the measurements together and dividing by 2 as shown in Example.



SHIM CHART

Gap 1 = .060; Gap 2 = .050
Total Gap = .060 + .050 = .110

Bench Service Procedure

SHIM CHART

Average = $110/2 = .055$

Select yellow shim as indicated in the shim chart at the end of this selection.



9. Locate the feeler gauge average measurement in the shim chart to determine the required shim and color code.

Note: The oil pump shim is used when an auxiliary oil pump or PTO is mounted on the countershaft. The oil pump shims have a smaller outside diameter.

10. Remove the countershaft rear bearing cover and gauging shim.
11. Place the selected shim on the rear countershaft bearing race.

12. Position a new gasket on countershaft rear bearing cover mounting surface.

13. Position the countershaft rear bearing cover over the new gasket.

14. Apply Eaton® Fuller® thread sealant #71205 or equivalent to the auxiliary countershaft rear bearing cover capscrews and auxiliary countershaft rear bearing cover.

15. Install the auxiliary countershaft rear bearing cover and secure it with the capscrews. Make sure the shim is in the proper location and is not pinched between the cover and the housing. Tighten the capscrews to 40-45 lbs. ft. (54-61 N•m).

Note: Use a thick grease to hold the shim in position when installing the cover.

16. Repeat this procedure for the remaining countershaft.

Note: Make sure capscrews are properly torqued.

Note: Make sure the input shaft rotates.

SHIM TABLE

Feeler Gauge Average Gap	Shim Thickness	Standard Shim Part Number	Oil Pump Shim Part Number	Color Code
.072-.075	.033-.034	4302345	4302346	Gold
.69-.0715	.036-.037	21452	21472	Red
.066-.0685	.039-.040	21453	21473	Pink
.063-.0655	.042-.043	21454	21474	Brown
.060-.0625	.045-.046	21455	21475	Tan
.057-.0595	.048-.049	21456	21476	Orange
.054-.0565	.051-.052	21457	21477	Yellow
.051-.0535	.054-.055	21458	21478	Green
.048-.0505	.057-.058	21459	21479	Light Blue
.045-.0475	.060-.061	21460	21480	Lavender
.042-.0445	.063-.064	21461	21481	White
.039-.0415	.066-.067	21684	21686	Black
.036-.0385	.069-.070	21685	21687	Silver

Copyright Eaton Corporation, 2012. Eaton hereby grant their customers, vendors, or distributors permission to freely copy, reproduce and/or distribute this document in printed format. It may be copied only in its entirety without any changes or modifications. THIS INFORMATION IS NOT INTENDED FOR SALE OR RESALE, AND THIS NOTICE MUST REMAIN ON ALL COPIES.

Note: Features and specifications listed in this document are subject to change without notice and represent the maximum capabilities of the software and products with all options installed. Although every attempt has been made to ensure the accuracy of information contained within, Eaton makes no representation about the completeness, correctness or accuracy and assumes no responsibility for any errors or omissions. Features and functionality may vary depending on selected options.

For spec'ing or service assistance, call 1-800-826-HELP (4357) or visit www.eaton.com/roadranger. In Mexico, call 001-800-826-4357.

Roadranger: Eaton and trusted partners providing the best products and services in the industry, ensuring more time on the road.

Eaton Corporation

Vehicle Group
P.O. Box 4013
Kalamazoo, MI 49003 USA
800-826-HELP (4357)
www.eaton.com/roadranger

Printed in USA

For parts or service call us
Pro Gear & Transmission, Inc.



1 (877) 776-4600

(407) 872-1901

parts@eprogear.com

906 W. Gore St.

Orlando, FL 32805

