

# Fuller Medium Heavy Transmissions TRSM0202

October 2007



*Powering Business Worldwide*

BACKED BY

**Roadranger**

SUPPORT

For parts or service call us  
Pro Gear & Transmission, Inc.



**1 (877) 776-4600**

**(407) 872-1901**

**parts@eprogear.com**

**906 W. Gore St.**

**Orlando, FL 32805**





# Service Manual

- Operation
- Lubrication
- Maintenance
- Repair

## **T-955 Series**

Fuller<sup>®</sup>  
Twin Countershaft  
Transmissions

# Table of Contents

Model Designations .....	3	Inspection .....	46
Description .....	4	Gasket Locations .....	47
Specifications .....	4	Torque Ratings .....	48
Gear Ratios .....	5	Reassembly Precautions .....	49
Operation .....	6	Reassembly Instructions .....	50
Lubrication .....	10		
Preventive Maintenance Check Chart .....	12	I. Auxiliary Section - T-955ALL Models	
Disassembly Precautions .....	14	A. Low Speed Gear and Output Shaft .....	50
Disassembly Instructions .....	15	B. Rear Bearing Assembly .....	52
I. Shifting Controls		C. Low Gear Shift Cylinder Assembly .....	54
A. Low Gear Shift Air System (T-955ALL Models) .....	16	D. Range Mainshaft and First Speed Gear .....	56
B. Gear Shift Lever Housing Assembly .....	17	E. Auxiliary Countershafts .....	58
C. Shift Bar Housing Assembly .....	18	II. Auxiliary Section - T-955AL, T-955GL Models	
II. Clutch Housing, Companion Flange and Auxiliary Section		A. First Speed Gear and Output Shaft .....	60
A. Removal of the Clutch Housing .....	22	B. Output Shaft and Rear Bearing Installation .....	62
B. Companion Flange or Yoke .....	23	C. Auxiliary Countershaft Assemblies .....	64
C. Auxiliary Rear Section .....	23	D. First-reverse Speed Sliding Clutch .....	65
III. Front Section		III. Front Section	
A. Auxiliary Drive Gear Assembly .....	24	A. Right Reverse Idler Gear Assembly .....	66
B. Left Reverse Idler Gear Assembly .....	26	B. Countershaft Assemblies .....	68
C. Right Countershaft Bearing Removal .....	28	C. Drive Gear Assembly .....	70
D. Mainshaft Assembly .....	29	D. Left Countershaft Installation .....	73
E. Left Countershaft Bearing Removal .....	31	E. Mainshaft Assembly .....	74
F. Input Shaft and Drive Gear Assembly .....	32	F. Right Countershaft Installation .....	81
G. Countershaft Assemblies .....	34	G. Left Reverse Idler Gear Assembly .....	82
H. Right Reverse Idler Gear Assembly .....	35	H. Auxiliary Drive Gear Assembly .....	84
IV. Auxiliary Section - T-955AL, T-955GL Models		IV. Clutch Housing, Companion Flange and Auxiliary Section	
A. First-reverse Speed Sliding Clutch Gear .....	36	A. Clutch Housing .....	86
B. Auxiliary Countershaft Assemblies .....	37	B. Auxiliary Rear Housing .....	87
C. First Speed Gear, Output Shaft and Rear Bearing Assembly .....	38	C. Companion Flange or Yoke .....	87
V. Auxiliary Section - T-955ALL Models		V. Shifting Controls	
A. Auxiliary Countershaft Assemblies .....	40	A. Shift Bar Housing Assembly .....	88
B. Sliding Clutch and First Speed Gear .....	41	B. Gear Shift Lever Housing Assembly .....	92
C. Low Gear Shift Cylinder .....	42	C. Low Gear Air System (T-955ALL Models) .....	93
D. Range Mainshaft .....	44	Air System .....	94
E. Low Speed Gear, Output Shaft and Rear Bearing Assembly .....	45	Mainshaft Axial Clearance Chart .....	95
		Tool Reference .....	96

## **Model Designations**

- T-955AL – Six speed, direct drive.
- TO-955AL – Six speed, overdrive.
- T-955GL – Six speed, gathered ratios.
- T-955ALL – Seven speed, direct drive.
- TO-955ALL – Seven speed, overdrive.

Unless stated otherwise, this manual applies to all models in the T-955 series which includes: T-955AL, TO-955AL, T-955ALL, TO-955ALL, T-955GL

### **NOTE**

**Illustrated parts lists with parts numbers are available upon request.**

## Description

These 950 lb.-ft. torque capacity units are designed to take advantage of the power curve of the high torque rise engines and to give the ratio spread necessary for construction vehicles.

The T-955AL and TO-955AL six speed models have ratios for construction vehicles, especially dump truck operation. The 11.17 low gear provides ample reduction for starting heavy loads, yet can be shifted progressively without stopping vehicle. The two reverse ratios, progressively shifted, provide fast backing speeds plus deep reduction for job-site spotting. The TO-955AL overdrive model gives a .65 overdrive ratio where heavy duty drive axles are needed and ratio choices are limited.

The T-955ALL and TO-955ALL seven speed models, especially suited for both dump and mixer operations, provide the reduction for extremely adverse conditions, also ratios for curbing and paving. Three reverse ratios give a range for stockpiling, job-site work and load spotting. The TO-955ALL overdrive model is available to obtain highway speeds when heavy duty axle ratio choice is limited.

The T-955GL model has special “gathered” ratios for vehicles operating primarily on highway.

## Specifications

### Speeds

T-955AL, GL: 6 forward speeds, 2 reverse  
T-955ALL: 7 forward speeds, 3 reverse

### Power Take-Off

Right Side: regular duty, 6-bolt type  
45 tooth PTO gear  
Bottom: heavy duty, 8-bolt type  
47 tooth PTO gear

### PTO Gear Relative Speed to Input R.P.M.

T-955AL: .533, right side and bottom  
T-955GL: .700, right side and bottom  
TO-955AL: .820, right side and bottom  
T-955ALL: .533, right side and bottom  
TO-955ALL: .820, right side and bottom

**Torque Rating** 950 lb.-ft.

**Clutch Housing Size** SAE No. 1, 2 aluminum

### Length (from face of clutch housing to end of splines on tailshaft)

T-955AL, GL: 30 7/8”  
T-955ALL: 34 1/16”

### Weight

T-955AL, GL: 580 lbs.  
T-955ALL: 646 lbs.

### Oil Capacity (pints)

T-955AL, GL: 25  
T-955ALL: 28

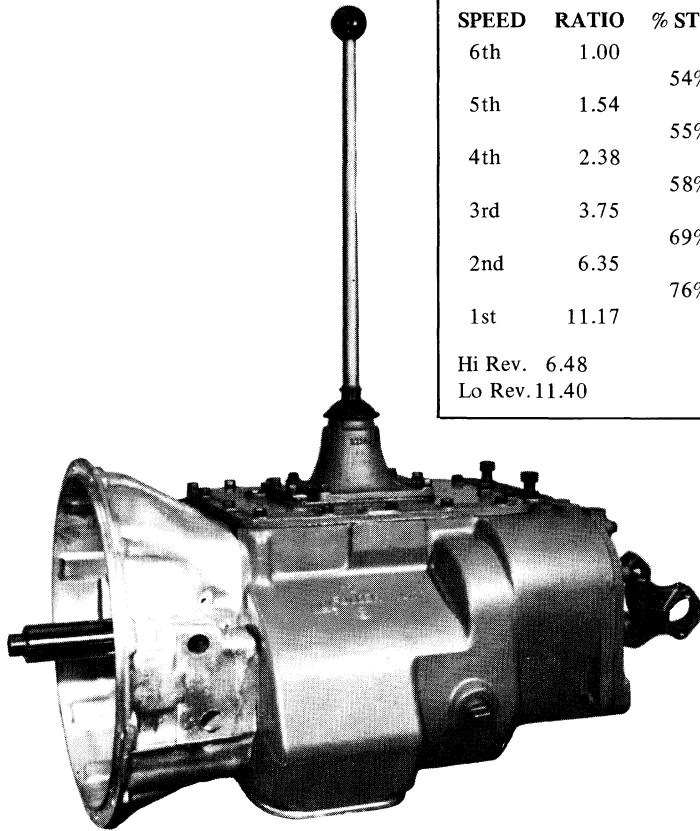

T-955AL			GEAR RATIOS TO-955AL			T-955GL		
SPEED	RATIO	% STEP	SPEED	RATIO	%STEP	SPEED	RATIO	% STEP
6th	1.00	54%	6th	.65	54%	6th	1.00	31%
5th	1.54	55%	5th	1.00	54%	5th	1.31	43%
4th	2.38	58%	4th	1.54	58%	4th	1.87	60%
3rd	3.75	69%	3rd	2.44	69%	3rd	2.99	62%
2nd	6.35	76%	2nd	4.13	76%	2nd	4.84	76%
1st	11.17		1st	7.26		1st	8.51	
Hi Rev.	6.48		Hi Rev.	4.21		Hi Rev.	4.94	
Lo Rev.	11.40		Lo Rev.	7.41		Lo Rev.	8.69	

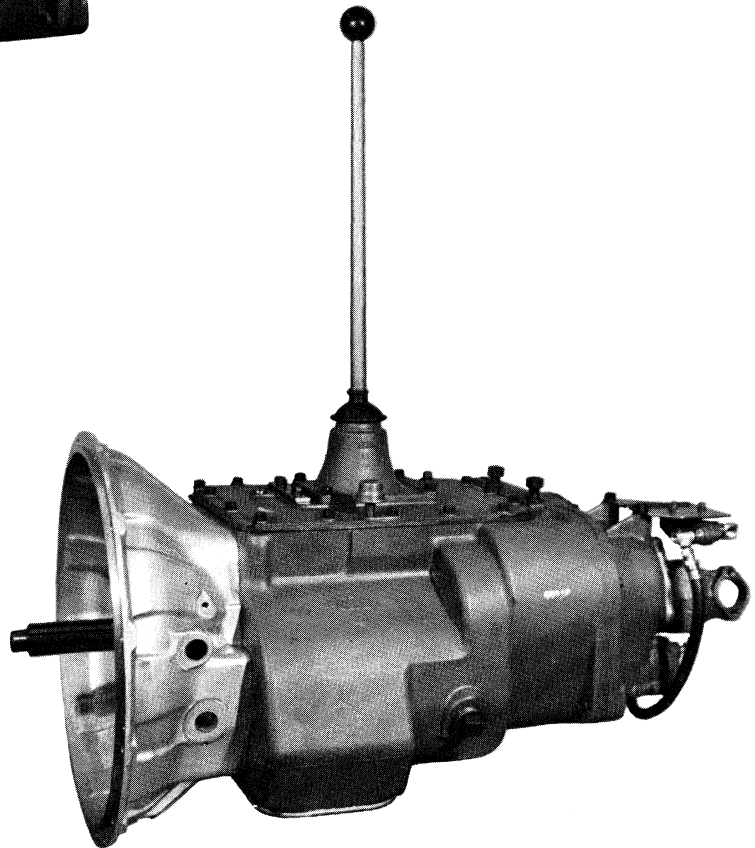

GEAR RATIOS					
T-955ALL			TO-955AL		
SPEED	RATIO	% STEP	SPEED	RATIO	% STEP
6th	1.00	54%	6th	.65	54%
5th	1.54	55%	5th	1.00	54%
4th	2.38	58%	4th	1.54	58%
3rd	3.75	69%	3rd	2.44	69%
2nd	6.35	76%	2nd	4.13	76%
1st	11.17	138%	1st	7.26	76%
Lo	26.54		Lo	17.25	138%
Hi Rev.	6.48		Hi Rev.	4.21	
Lo Rev.	11.40		Lo Rev.	7.41	
Lo-Lo Rev.	27.09		Lo-Lo Rev.	17.61	



# Operation

In the following instructions it is assumed that the driver is familiar with motor trucks and tractors, and that he can coordinate the necessary movement of the shift lever and clutch pedal to make progressive and selective gear engagements in either direction, up or down.

## Six Speed Models

T-955AL, T-955GL & TO-955AL Models

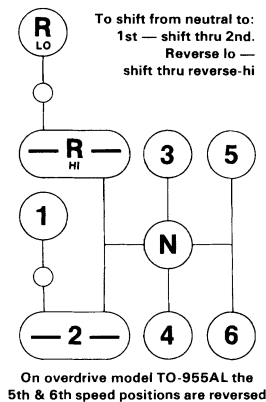

1. Start engine with gear shift lever in the neutral position.
2. To start vehicle moving, shift into the 1st speed position. This is done by moving the gear shift lever through the 2nd speed gear position with the clutch disengaged (it may be necessary to feather clutch to move lever into 2nd). Move lever through the 2nd speed gear position to the extreme left, then push lever forward into 1st gear.

*NOTE: While moving the lever into first you may feel the neutral position between 2nd and 1st gears. This neutral position can be used at stop lights, etc.*

3. After vehicle has gained sufficient speed in 1st gear, shift lever into the 2nd speed position.
4. Shift from 2nd to 3rd by moving lever from the extreme right in the second speed gear position into the 3rd speed position.

*NOTE: A spring and plunger will move the gear shift lever to the extreme right in the 2nd speed gear position. When shifting from 1st to 2nd the gear shift lever will be moved to the extreme right position; when shifting from 2nd to 1st, operator must move lever to the extreme left position while in 2nd gear position against the spring pressure.*

5. Shift on upward through 4th, 5th and 6th in the shift pattern. On overdrive models, the 5th and 6th speed gear positions are reversed.

## Reverse and Lo Reverse

To shift into reverse, move the gear shift lever into the reverse gear position.

To shift into Lo reverse; first shift into reverse, then move lever to the extreme left and forward into the lo reverse position (it may be necessary to feather clutch to move lever into reverse.)

### Seven Speed Models

T-955ALL and TO-955ALL Models

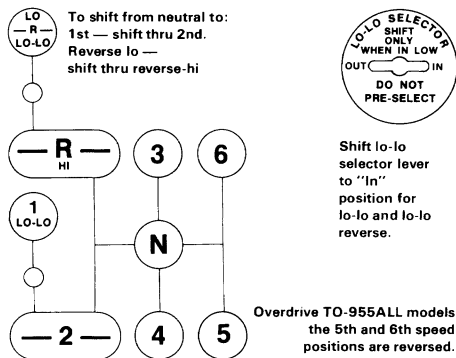

1. Start engine with gear shift lever in the neutral position.
2. To start vehicle moving under normal conditions, shift into the 1st speed position. This is done by moving the gear shift lever through the 2nd speed gear position with the clutch disengaged (it may be necessary to feather clutch to move lever into 2nd.) Move lever through the 2nd speed gear position to the extreme left, then push lever forward into 1st gear.

*NOTE: While moving the lever into first you may feel the neutral position between 2nd and 1st gears. This neutral position can be used at stop lights, etc.*

3. To shift into Lo-Lo under adverse conditions: To shift into Lo-Lo the gear shift lever must be in the 1st speed gear position. Switch the Lo-Lo selector from “Out” to “In” and **immediately** disengage and re-engage clutch; transmission will shift into Lo-Lo. To shift out of Lo-Lo, switch selector from “In” to “Out” and **immediately** disengage and re-engage clutch.
4. After vehicle has gained sufficient speed in 1st gear, shift lever to the 2nd speed position.
5. Shift from 2nd to 3rd by moving lever from the extreme right in the second speed gear position into the 3rd speed gear position.

*NOTE: A spring and plunger will move the gear shift lever to the extreme right in the 2nd speed gear position: when shifting from 1st to 2nd the gear shift lever will be moved to the extreme right position; when shifting from 2nd to 1st, operator must move lever to the extreme left position while in 2nd gear position against the spring pressure.*

6. Shift on upward through 4th, 5th and 6th in the shift pattern. On overdrive models, the 5th and 6th speed gear positions are reversed.

### Reverse, Reverse Lo and Lo-Lo

To shift into reverse, move the gear shift lever into the reverse gear position.

To shift into Lo reverse: first shift into reverse, then move lever to the extreme left and forward into the Lo reverse position (it may be necessary to feather clutch to move lever into reverse.)

To shift into Lo-Lo reverse: first shift into Lo reverse, then switch the Lo-Lo selector from “Out” to “In” and immediately disengage and re-engage clutch. To shift from Lo-Lo reverse to Lo reverse: switch selector from “In” to “Out” and immediately disengage and re-engage clutch.

*NOTE: Reverse gears can be shifted progressively without stopping vehicle.*

### Alternative Method of Upshifting the T-955ALL and TO-955ALL Transmissions

1. As in the previous instructions, start vehicle with gear shift lever in neutral and shift into the Lo-Lo position, moving the selector switch to the “In” position.
2. After vehicle has gained sufficient momentum, shift upward through the shift pattern through 2nd, 3rd, 4th and 5th to 6th, KEEPING THE SELECTOR SWITCH TO THE “IN” POSITION.
3. When in 6th and ready for the next UPSHIFT, switch the selector switch from “IN” to “OUT” and immediately move the gear shift lever to the 4th speed gear position. Remember this is an upshift.
4. Continue upshifting through 5th and 6th.

*NOTE: When using this method of shifting (by using the shift pattern with the selector switch to “IN”) it is necessary to move the gear shift lever two gear positions lower to make the upshift. For instance, if you are in 6th, switch selector from “IN” to “OUT”, and move gear shift lever to 4th; if you are in 5th, switch selector from “IN” to “OUT” and move gear shift lever to 3rd.*

Upshift Gear Positions Using Alternative Method of Shifting

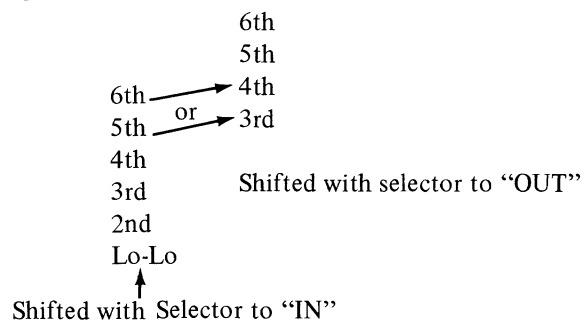

## To Convert From T-955AL To TO-955AL, or T-955ALL To TO-955ALL

To convert from an T-955AL or T-955ALL to an over-drive model TO-955AL or TO-955ALL the fifth speed gear on the mainshaft and mating gears, one on each countershaft, are interchanged with the main drive gear and mating countershaft drive gears.

The transmission front section must be completely disassembled to make the change as the drive gear on each

countershaft must be removed. When reassembling make sure gear hubs are in the right position as described in the detailed reassembly section of this manual.

Extra parts, other than gaskets, are not needed to make the conversion. A new drive gear bearing nut may be needed as this part may be damaged during removal.

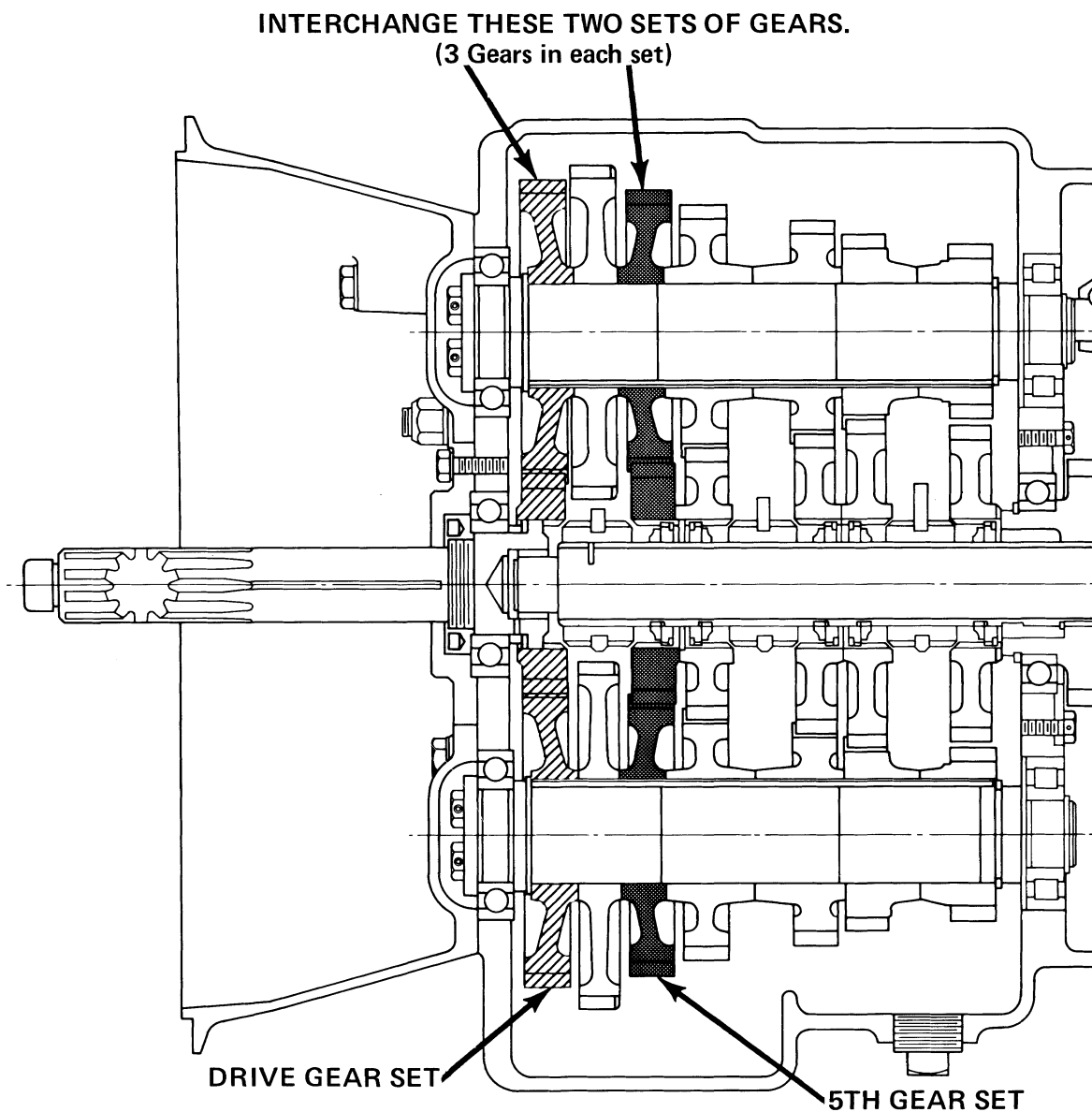

**FRONT SECTION OF T-955AL AND T-955ALL**

## Special Procedure For Changing Clutch (Input) Shaft

In some cases in field repair it may be necessary to replace only the input shaft due to clutch wear on the splines.

In these instances the input shaft can be removed without disassembling the transmission other than removing the shifting bar housing. Removal of the clutch housing is optional. Following is the detailed procedure:

### Disassembly

1. Remove gear shift lever housing and shift bar housing from transmission.
2. Remove the front bearing cover.
3. Engage the mainshaft sliding clutches in two gears and remove the drive gear bearing nut.
4. Move the drive gear assembly as far forward as possible and remove the drive gear bearing.
5. Remove the washer from input shaft.
6. From the front, remove the snap ring from ID of drive gear.
7. Pull the input shaft forward and from splines of drive gear.

### Reassembly

1. Install new input shaft into splines of drive gear just far enough to expose snap ring groove in ID of drive gear.
2. Install snap ring in ID of drive gear.
3. Install washer on shaft.
4. **IMPORTANT** – Move the sliding clutch gear forward to contact end of input shaft in hub of drive gear. Block between rear of sliding clutch and front of the fifth speed gear. When installing bearing this will hold input shaft in position to seat the bearing properly.
5. Install drive gear bearing on shaft and into case bore, making sure blocking remains in place.
6. Remove blocking from mainshaft and install the drive gear bearing nut, left-hand thread. Use Loctite sealant on threads of nut and shaft.
7. Peen nut into milled slots in shaft.
8. Re-install front bearing cover, shifting bar housing and gear shift lever housing.

*NOTE: The above instructions are for changing the input shaft only. To change the drive gear, complete disassembly of the front section must be made.*

## Lubrication

### RECOMMENDED LUBRICANTS

#### ON-HIGHWAY VEHICLES

Type	Grade	Temperature
Heavy Duty Engine Oil MIL-L-2104B	SAE 50 SAE 30	Above + 10°F. Below + 10°F.
Mineral Gear Oil R and O Type	SAE 90 SAE 80	Above + 10°F. Below + 10°F.
Mild E.P. Oil (except Sulfur-chlorine-lead type) MIL-L-2105B	SAE 90 SAE 80	Above + 10°F. Below + 10°F.

*Heavy-duty engine oil.* Make sure to specify heavy-duty type meeting MIL-L-2104B specifications.

*Mineral gear oil* inhibited against rust, oxidation and foaming.

*Extreme pressure oils* under some conditions might form carbon deposits on gears, shafts, bearings and synchronizer discs, and may also glaze friction surfaces of synchronizer discs – conditions which will result in transmission malfunction and premature failure. It is suggested that if these conditions exist, and E.P. oil is being used, a change should be made to mineral oil or heavy-duty engine oil as recommended.

#### OFF-HIGHWAY AND MINING EQUIPMENT

Heavy Duty Engine Oil MIL-L-2104B	SAE 50 SAE 30	Above + 10°F. Below +10°F.
Special Recommendation – For extreme cold weather where temperature is consistently below 0°F.		
Heavy Duty Engine Oil MIL-L-2104B	SAE 20W	Below 0°F.

FULLER TRANSMISSIONS are designed so that the internal parts operate in a bath of oil circulated by the motion of gears and shafts. Grey iron parts have built-in channels where needed, to help lubricate bearings and shafts.

Thus, all parts will be amply lubricated if these procedures are closely followed:

1. **Maintain oil level. Inspect regularly.**
2. **Change oil regularly.**
3. **Use the correct grade and type of oil.**
4. **Buy from a reputable dealer.**

To keep the gear oil clean between oil changes use the Fuller Transmission Gear Oil Filter which can be attached to the right-side power take-off opening. This assembly includes a replaceable filter element that removes the accumulation of metallic particles, road dirt and grit deposited in the lubricant.

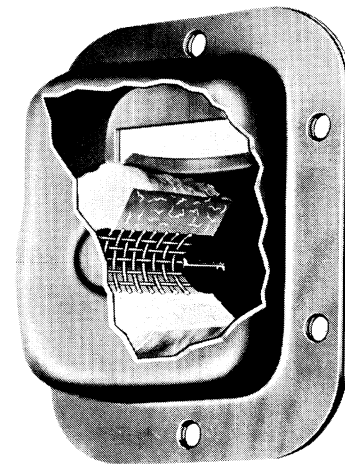

*Fuller Transmission Gear Oil Filter*

### Draining Oil

To drain the transmission remove the drain plug at the bottom of the front case. Drain oil when transmission is warm. After the transmission has been drained and before it is refilled, the case should be thoroughly flushed with a clean flushing oil or kerosene. Do not use flushing compound if unit is equipped with side or front mounted pressure lubrication pumps unless pump is removed and opening covered with plate. Clean both drain plugs before reinstalling.

### Refilling

In order to assure complete filling of the transmission with oil, the following two methods may be used:

- 1) At any inclination: Plug the fill hole in the front case and add entire quantity through opening in shift bar housing. The transmission must be *completely drained* before using this method in order to avoid overfilling.
- 2) At upgrade inclinations from 0 through 3 degrees: Add sufficient quantities through the fill hole to level the oil at the bottom of the fill hole.

Do not overfill. Overfilling will cause the oil to be forced out of the case through the mainshaft openings.

### Adding Oil

It is recommended that types and brands of oil not be intermixed because of possible incompatibility.

Additions of oil during servicing operations should be made through the fill hole to level the oil at the bottom of the fill hole with the transmission at a 0 to 3 degree upgrade angle.

### Operating Temperature

It is imperative that the operating temperature of the transmission does not exceed 250°F.

Extensive operation at temperatures exceeding 250°F. will result in rapid breakdown of the oil and shorten transmission life.

Transmissions used in stationary equipment, or in vehicles operating at slow road speeds, may have to be equipped with external coolers so that the 250°F. temperature is not exceeded.

### Inspection

Gear oil is to be kept even with the level of the filler opening at all times. Check at the following intervals:

- Highway Service .....1,000 miles
- Off-highway Service .....40 hours

### Gear Oil Change

Change the gear oil on all new equipment after the first 3000 to 5000 miles (on-highway), or first 40 hours (off-highway); thereafter, make oil changes as follows:

- Highway Service .....25,000 miles
- Off-highway Service
  - Logging and associated operations ..... 1,000 hours
  - Dirt moving, mining and associated operations .....250 to 500 hours, as indicated by operation and contamination of lubricant.

### Special Recommendation

The above oil inspection and change periods are based on the average use and operating conditions for the applications listed. It is recommended that the individual owner make a periodic lab analysis of the lubricant to determine contamination based on the individual's own operating conditions. After this has been determined, the individual owner can then set his own inspection and oil change periods.

### Clutch Release Bearing

Follow vehicle manufacturer's chassis lubrication recommendations.

### Oil Filter

If so equipped, replace filter element at each oil change; clean filter element housing.

**Preventive Maintenance Check Chart**

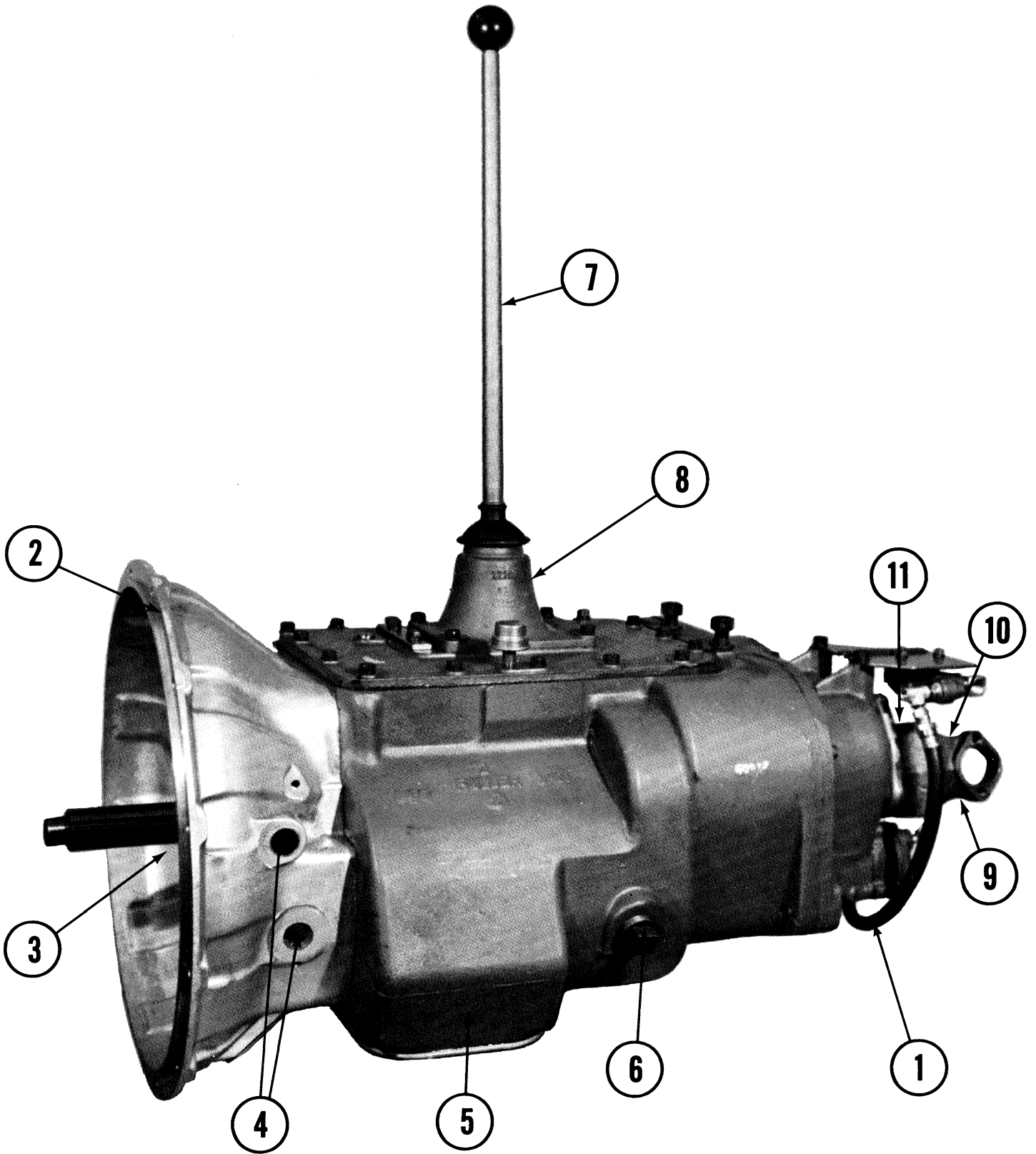

## Preventive Maintenance Check Chart

### CHECKS WITHOUT PARTIAL DISASSEMBLY OF CHASSIS OR CAB

- 1. Air System and Connections (T-955ALL)**
  - a. Check for leaks, worn air lines, loose connections and capscrews, See Air Systems, page 94.
- 2. Clutch Housing Mounting**
  - a. Check all capscrews in bolt circle of clutch housing for looseness.
- 3. Clutch Release Bearing**
  - a. Remove hand hole cover and check radial and axial clearances in release bearing.
  - b. Check relative position of thrust surface of release bearing with thrust sleeve on push type clutches.
- 4. Clutch Pedal Shaft and Bores**
  - a. Pry upward on shafts to check wear.
  - b. If excessive movement is found, remove clutch release mechanism and check bushings in bores and wear on shafts.
- 5. Gear Lubricant**
  - a. Change at specified service intervals.
  - b. Use only gear oils as recommended. See Lubrication section.
- 6. Filler and Drain Plugs**
  - a. Remove filler plug and check level of lubricant at specified intervals. Tighten filler and drain plugs securely.
- 7. Gear Shift Lever**
  - a. Check for looseness and free play in housing. If lever is loose in housing, proceed with Check No. 8.

- 8. Gear Shift Lever Housing Assembly**
  - a. Remove the gear shift lever housing assembly from transmission.
  - b. Check tension spring and washer for set and wear.
  - c. Check the gear shift lever pivot pin and pivot pin slot for wear.
  - d. Check bottom end of gear shift lever for wear and check slot of yokes and blocks in shift bar housing for wear at contact points with shift lever.

### CHECKS WITH DRIVE LINE DROPPED

- 9. Universal Joint Companion Flange Nut**
  - a. Check for tightness. Tighten to recommended torque.

### CHECKS WITH UNIVERSAL JOINT COMPANION FLANGE REMOVED

- 10. Output Shaft**
  - a. Check splines for wear from movement and chucking action of the universal joint companion flange.
  - b. Pry upward against output shaft to check radial clearance in mainshaft rear bearing.
- 11. Mainshaft Rear Bearing Cover**
  - a. Check oil seal for wear.



## General Precautions for Disassembly

**IMPORTANT: Read this section before starting the detailed disassembly procedures**

It is assumed in the detailed disassembly instructions that the lubricant has been drained from the transmission, the necessary linkage and air lines removed and the transmission has been removed from the chassis. Removal of the gear shift lever housing assembly is included in the detailed instructions; however, this assembly must also be removed from transmission before removing unit from vehicle.

The two control valve air lines must be disconnected at the transmission before removing unit from vehicle. (T-955ALL)

Follow each procedure closely in each section, making use of both the text and pictures.

1. **BEARINGS** – Carefully wash and relubricate all bearings as removed and protectively wrap until ready for use. Remove bearings with pullers designed for this purpose.

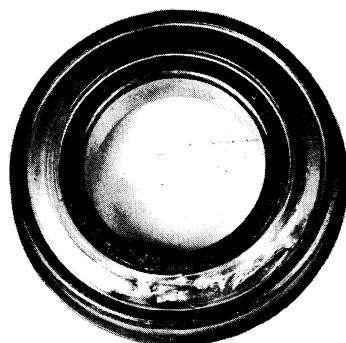

BEARING  
REMOVED WITH  
PUNCH, DAMAGED  
SHIELD.

BEARING  
REMOVED WITH  
CHISEL, DAMAGED  
OUTER RACE.

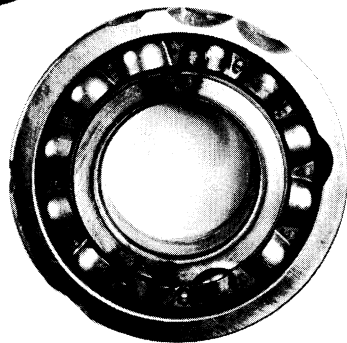

2. **ASSEMBLIES** – When disassembling the various assemblies, such as the mainshaft, countershafts and shifting bar housing, lay all parts on a clean bench in the same sequence as removed. This procedure will simplify reassembly and reduce the possibility of losing parts.

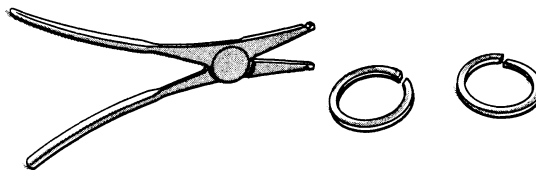

3. **SNAP RINGS** – Remove snap rings with pliers designed for this purpose. Rings removed in this manner can be reused.
4. **INPUT SHAFT** – The clutch or input shaft can be removed without removing the countershafts, mainshaft or drive gear.
5. **CLEANLINESS** – Provide a clean place to work. It is important that no dirt or foreign material enters the unit during repairs. The outside of the unit should be carefully cleaned before starting the disassembly. Dirt is abrasive and can damage bearings.
6. **WHEN DRIVING** – Apply force to shafts, housings, etc., with restraint. Movement of some parts is restricted. Do not apply force after the part being driven stops solidly. Use soft hammers and bars for all disassembly work.

# DISASSEMBLY INSTRUCTIONS

## I. Shifting Controls

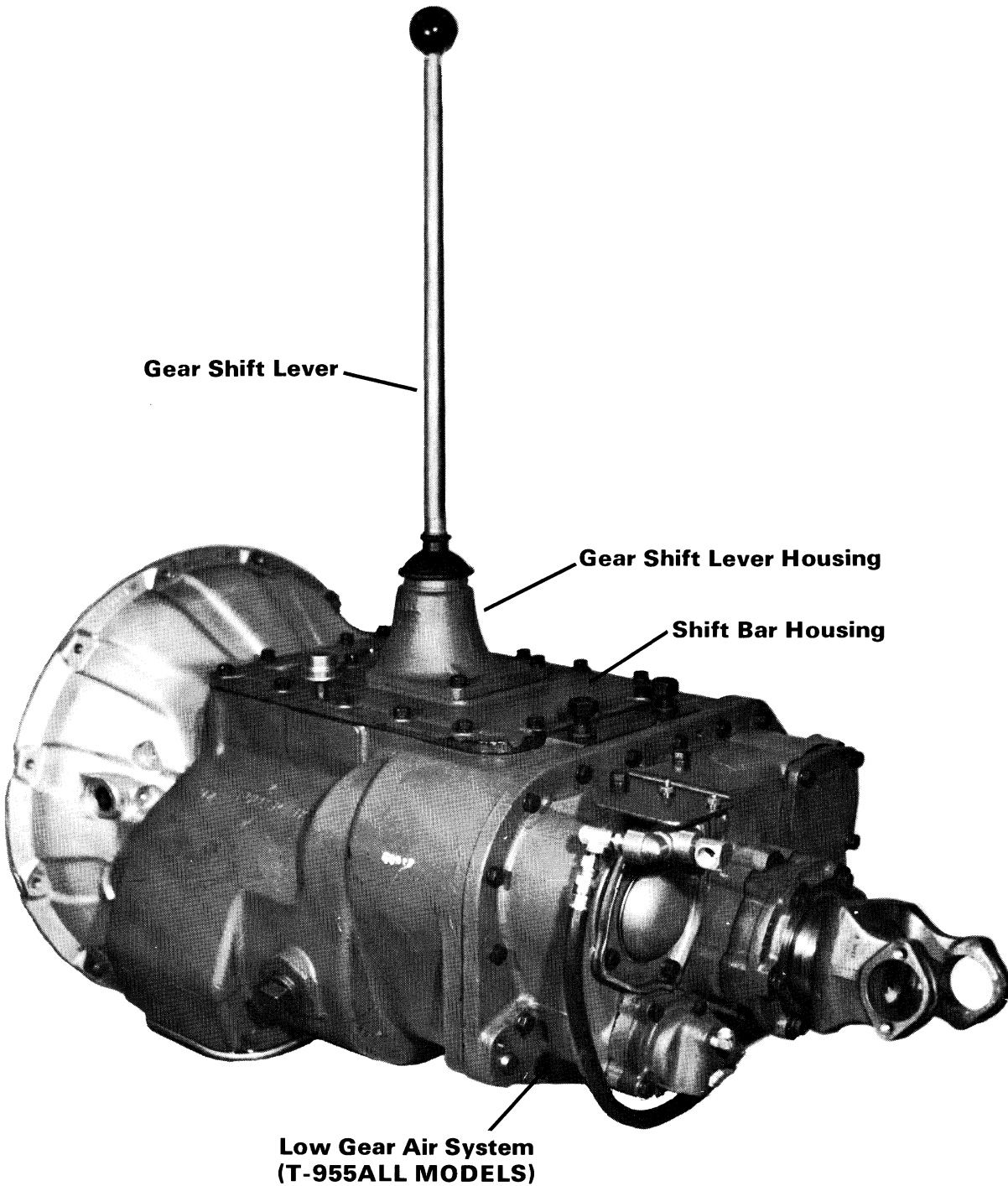

A. Removal of the Low Gear Shift Air System (T-955ALL Models)

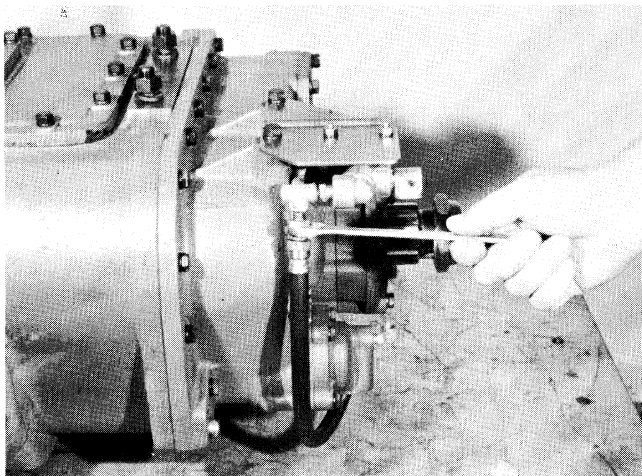
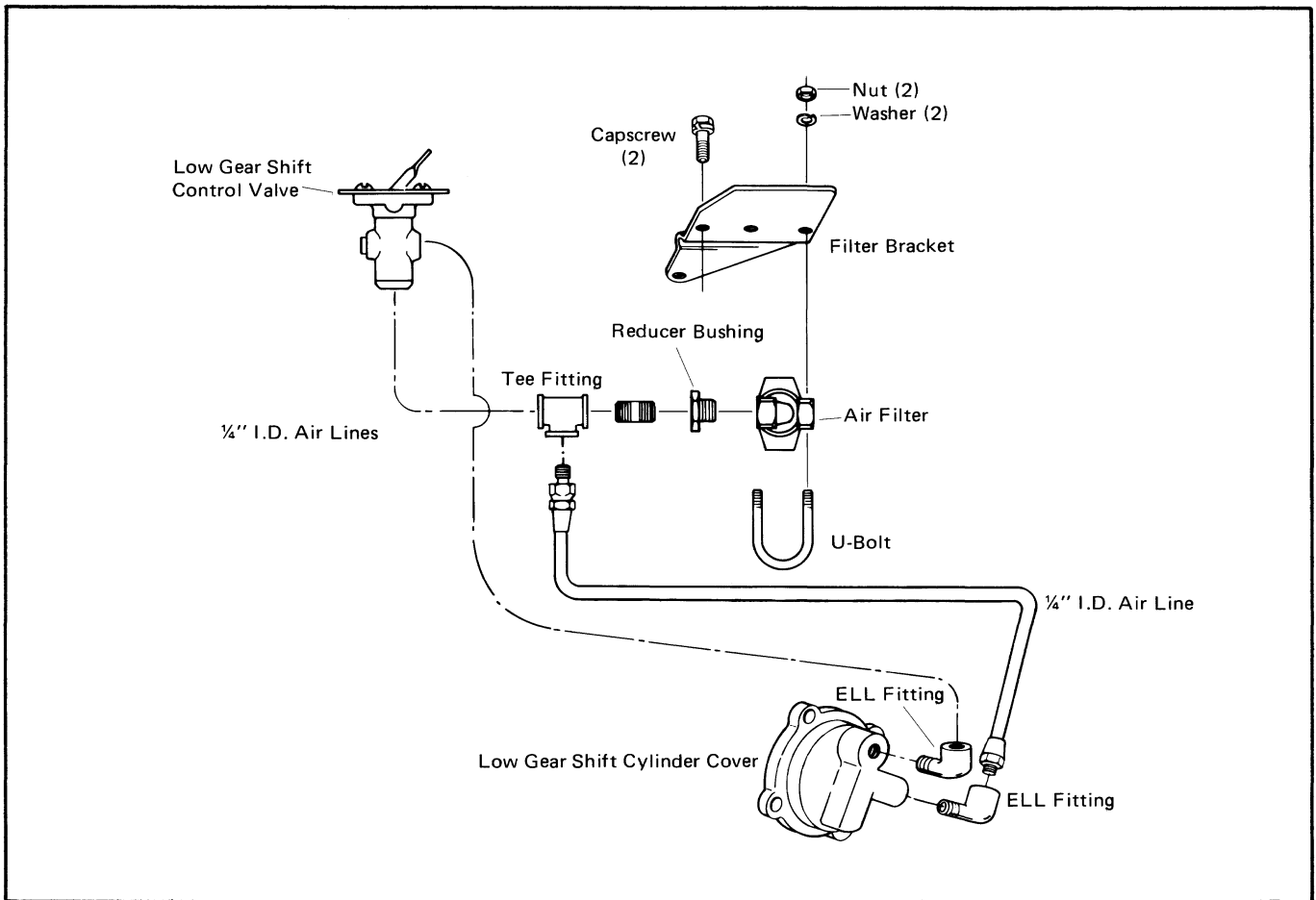

1. Disconnect the air line between the tee fitting forward of the air filter and the low gear shift cylinder.

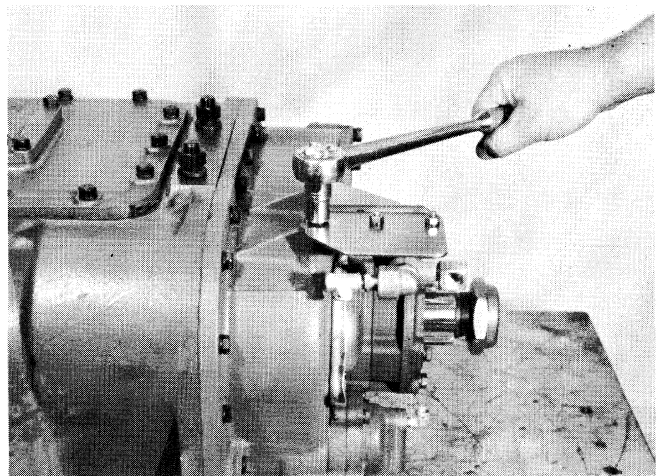

2. Turn out the two capscrews and remove the air filter and bracket assembly. For disassembly and maintenance of the filter, refer to page 94.

**B. Removal and Disassembly of the Gear Shift Lever Housing Assembly**

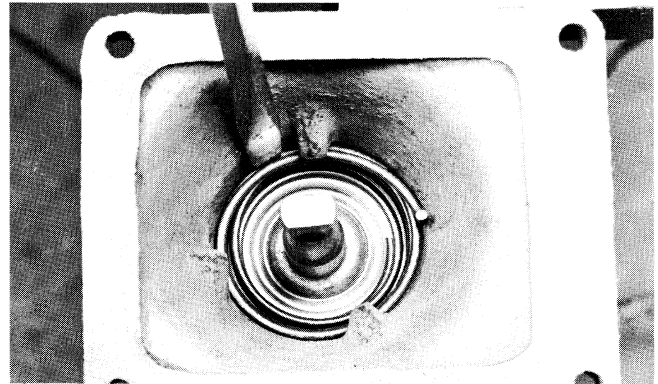
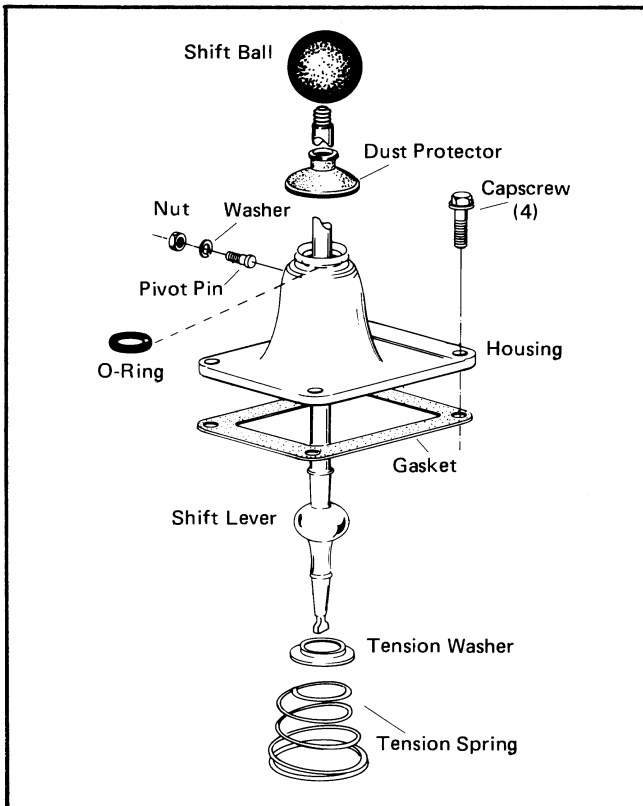

2. Mount the assembly in a vise, upside down, by the housing and using a large, heavy-bladed screwdriver, pry the tension spring up and over the lugs in the housing, one coil at a time. Remove the spring from the housing.



3. Remove the tension spring washer from the housing and pull the lever up and from the housing.

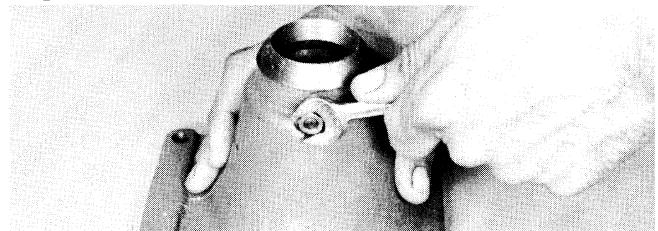

4. If necessary, remove the nut, pivot pin and washer from the housing.

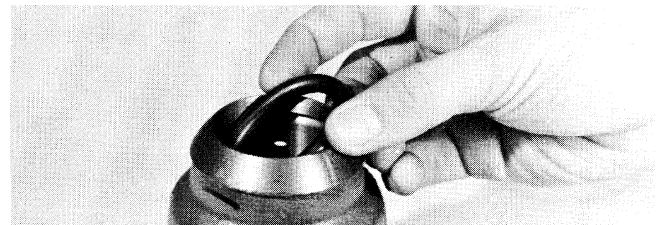

5. Remove the O-ring from the groove in the top of the housing.

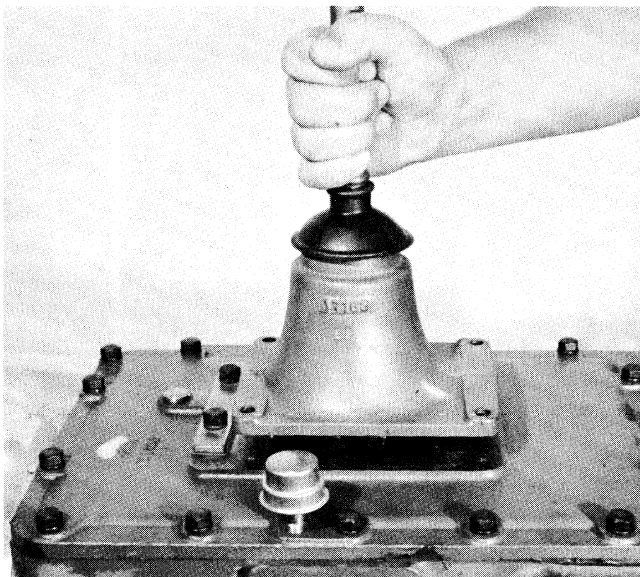

1. Turn out the four capscrews, jar lightly to break the gasket seal and lift the gear shift lever housing from the shift bar housing. Turn the shift ball from the lever and remove the rubber dust protector.

C. Removal and Disassembly of the Shift Bar Housing Assembly

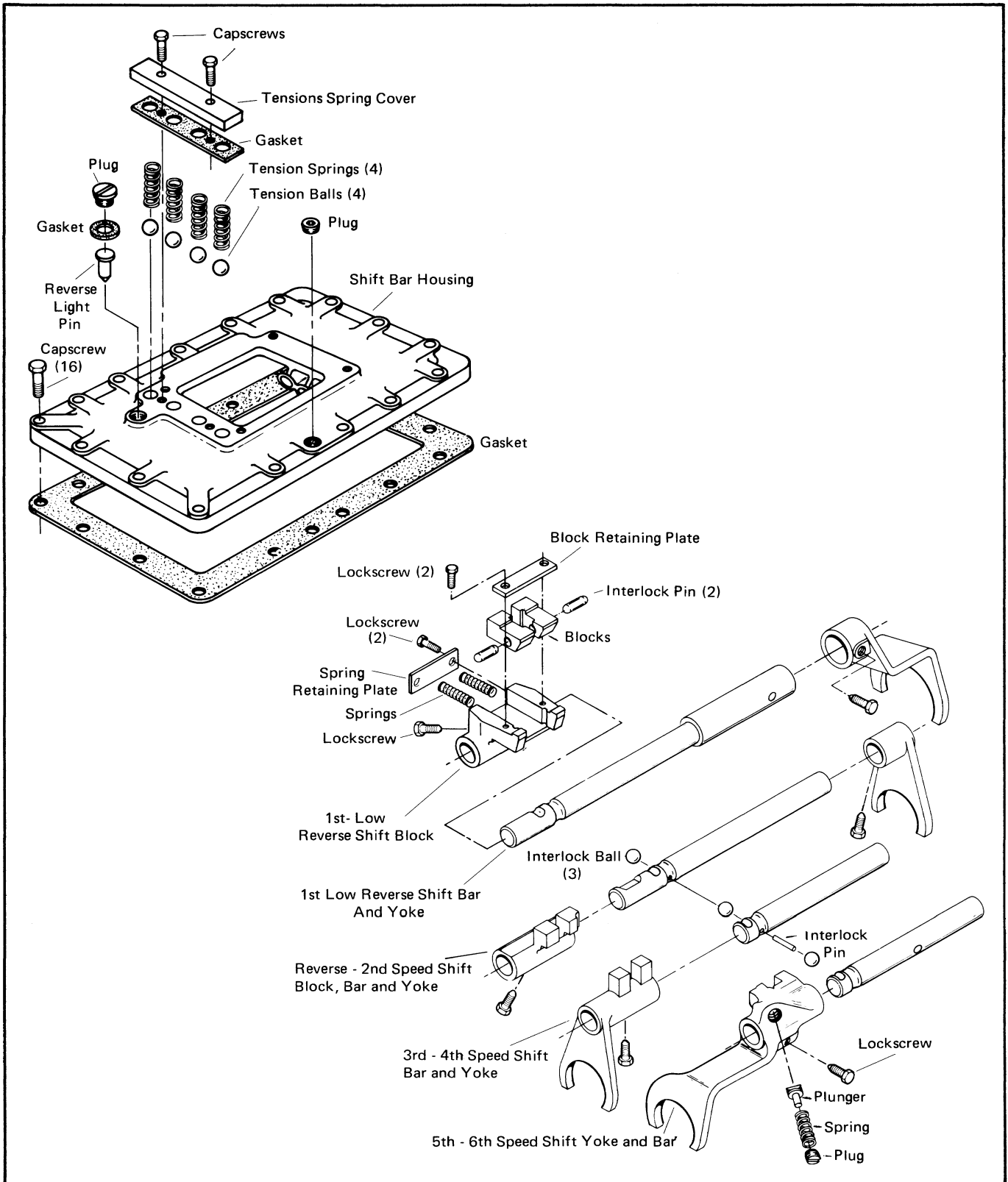

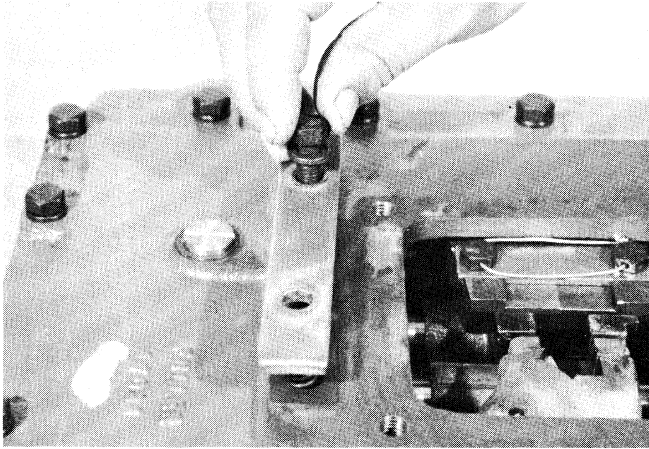

1. Turn out the two retaining cap screws and remove the tension spring cover.

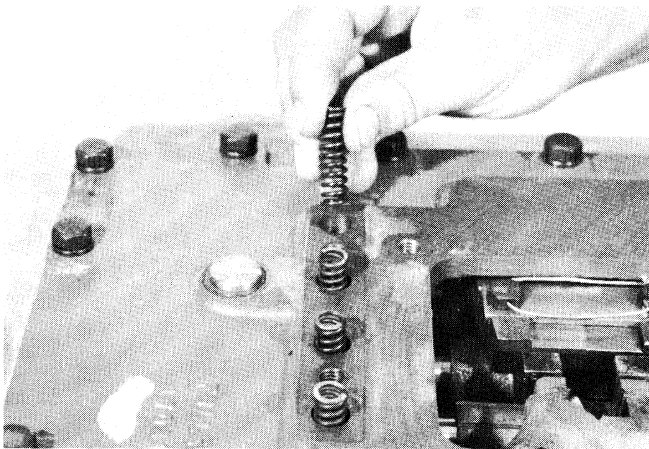

2. Remove the four tension springs.

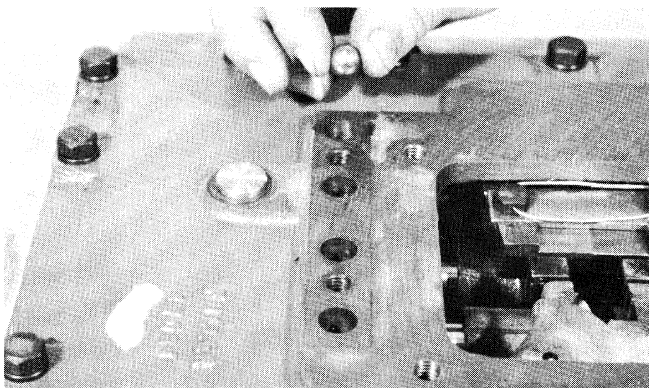

3. Use a magnet to remove the four tension balls located under the springs. If a magnet is not available, remove the balls by tipping the housing after it has been removed from the transmission.

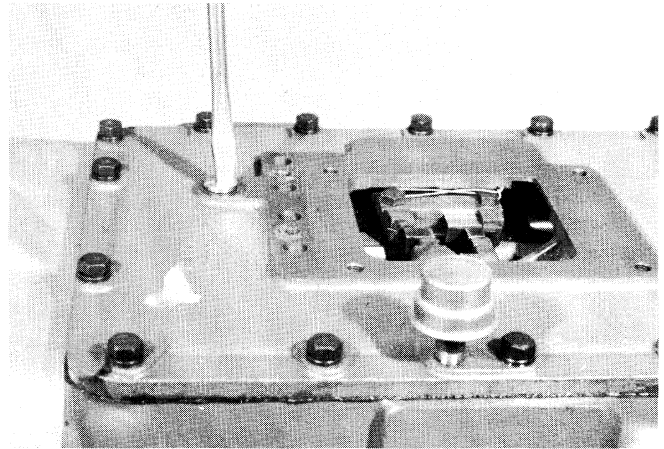

4. If necessary, remove the reverse light pin and plug from the housing.

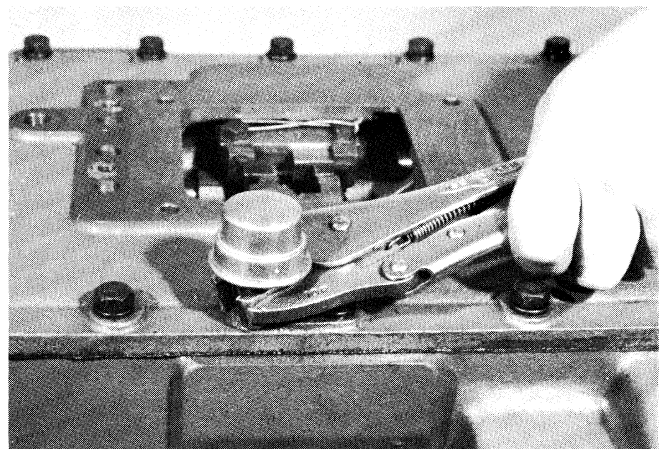

5. If necessary, use pliers or vise-grips to remove the air breather.

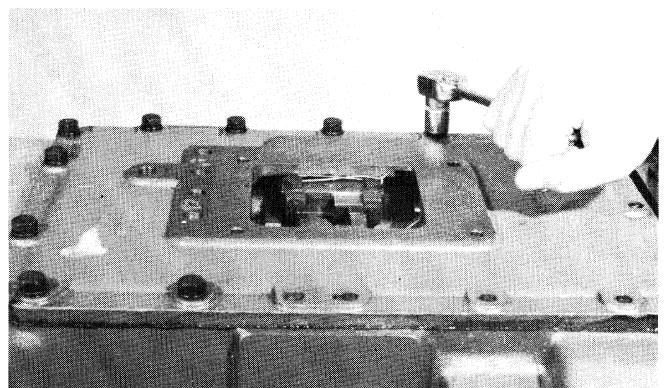

6. Turn out the 16 retaining cap screws, jar to break the gasket seal and lift the shift bar housing from the transmission.

**C. Removal and Disassembly of the Shift Bar Housing Assembly — continued**

**NOTE:** In the following steps for ease of reassembly, place all parts in their order of removal on a clean workbench, placing the correct shift yokes and blocks on each bar. Bars not being removed must be kept in the neutral position or interlock parts will lock the bars, preventing removal.

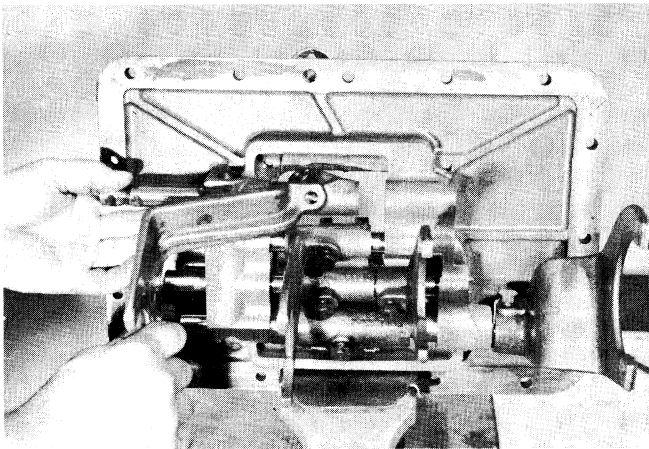

7. Mount the shift bar housing in a vise with the shortest shift bar to the top and cut all lockwires. Turn out the lock screw and pull the short (5th-6th speed) shift bar from the shift yoke and web of the housing. If necessary, use a screwdriver to turn out the plug and remove the spring and plunger from the shift yoke.

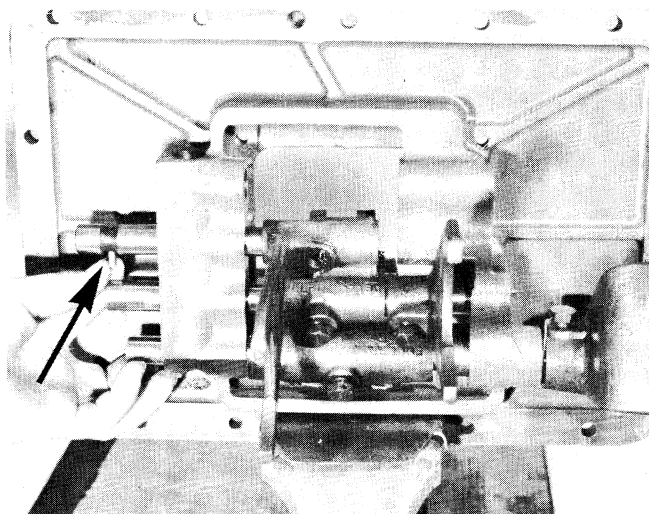

8. Turn out the lock screw and pull the 3rd-4th speed shift bar from the yoke and web of the housing. As the bar clears the web the interlock pin will fall from the bore in the bar.

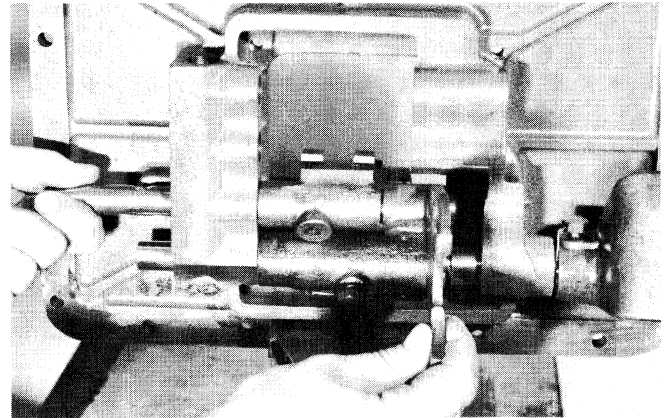

9. Turn out the two lock screws and pull the 2nd-reverse shift bar from the web of the housing and the shift yoke and block.

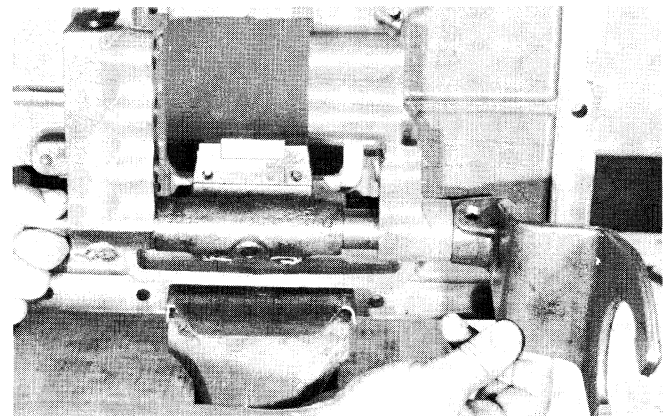

10. Turn out the two lock screws and pull the 1st-low reverse shift bar from the web of the housing and the shift yoke and block.

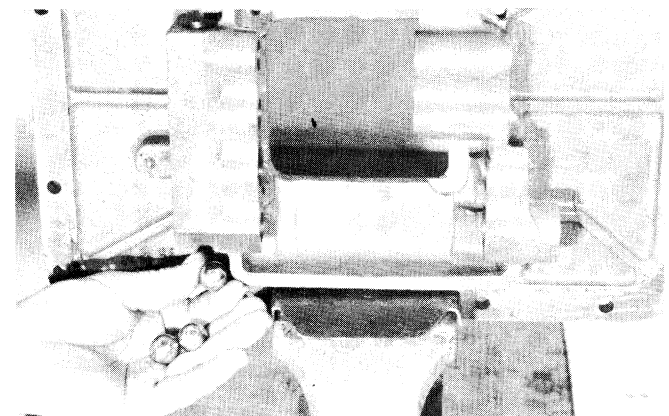

11. Three interlock balls are located in the web of the housing. These will fall from the web as the last shift bar is removed or may have to be removed from the web.

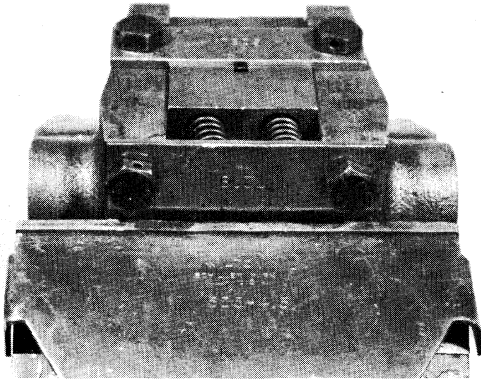

12. Mount the 1st-low reverse shift block in a vise and remove the two sets of lockwires.

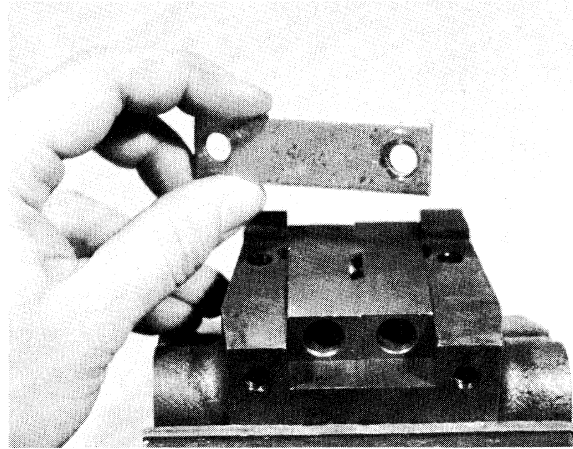

15. Turn out the two lock screws and remove the block retaining plate.

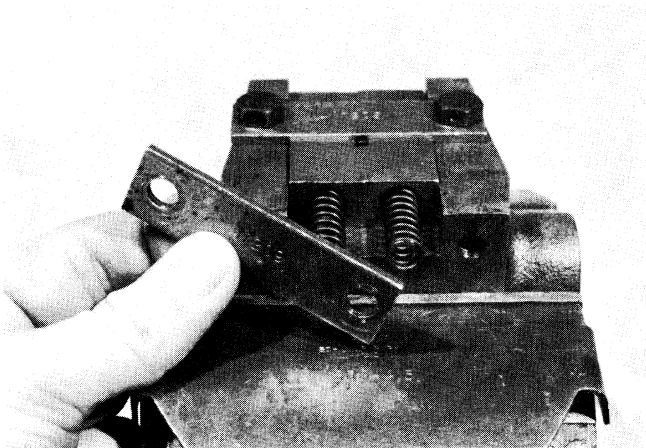

13. Turn out the two lock screws evenly and remove the spring retaining plate.

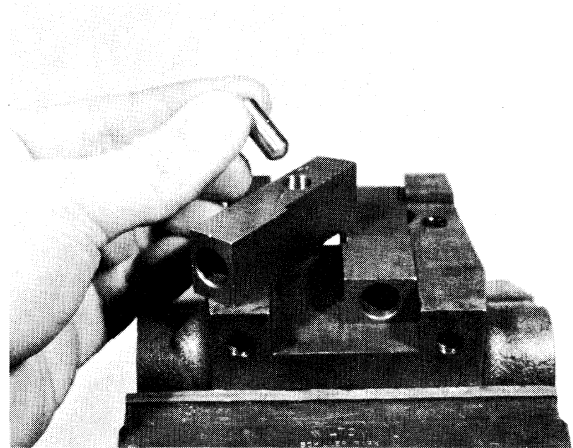

16. Remove the two blocks and remove the interlock pin from each block.

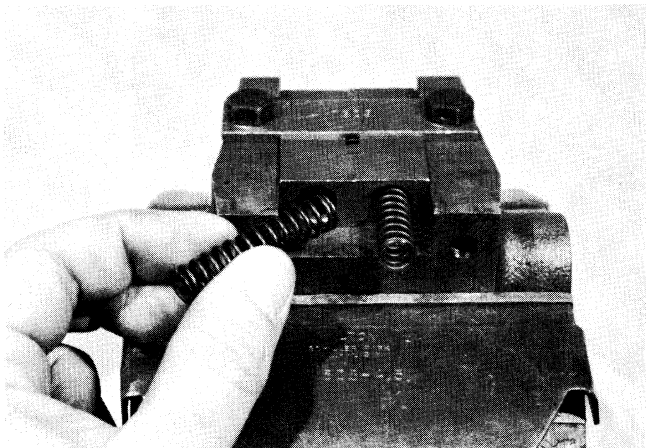

14. Remove the two springs from the bores.



## II. Clutch Housing, Companion Flange and Auxiliary Section

### A. Removal of the Clutch Housing

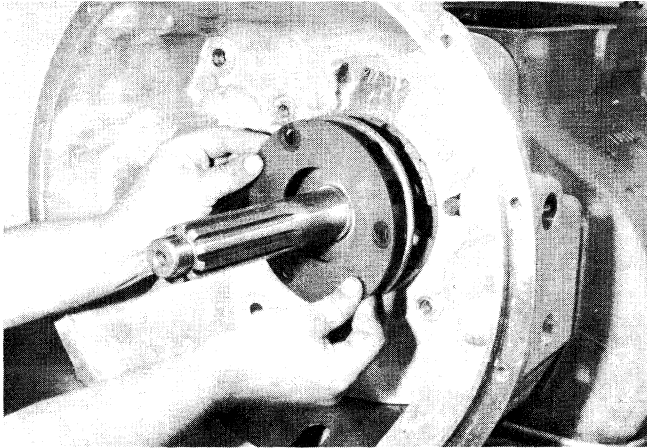

1. If so equipped, remove the upshift clutch brake assembly from the front bearing cover.

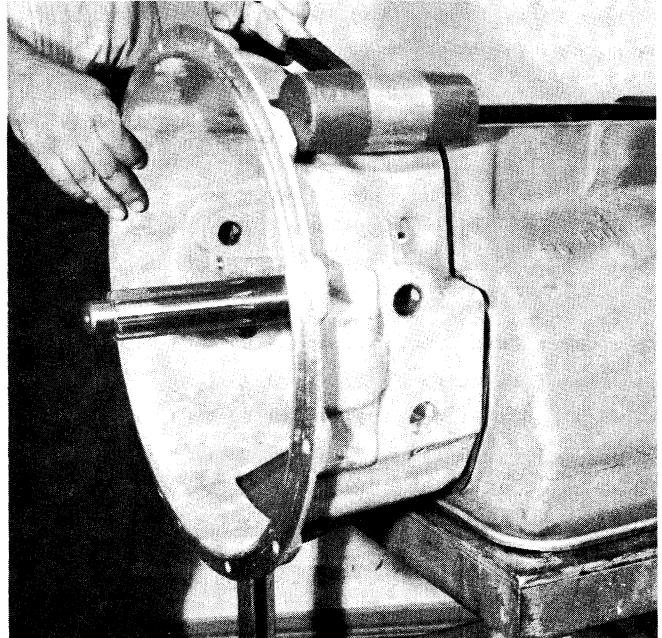

3. Use a rubber mallet to tap the clutch housing forward and off the front bearing cover and studs.

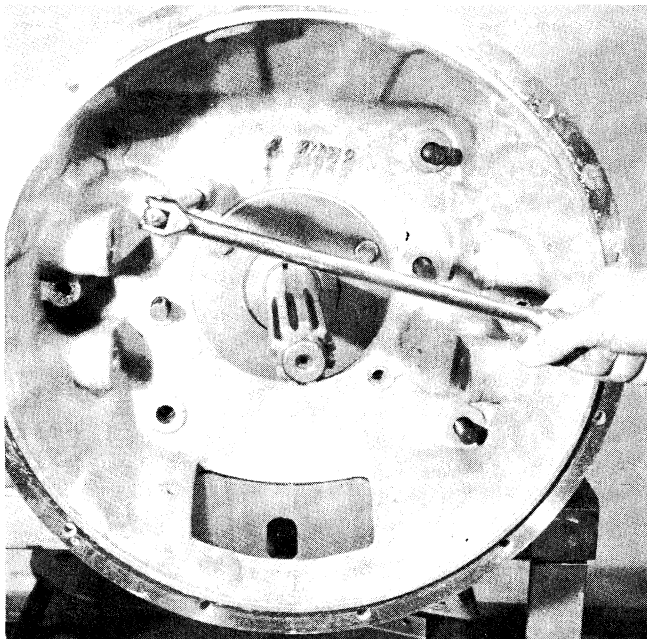

2. Turn out the four bolts and six nuts which attach the clutch housing to the transmission.

### B. Removal of the Companion Flange or Yoke

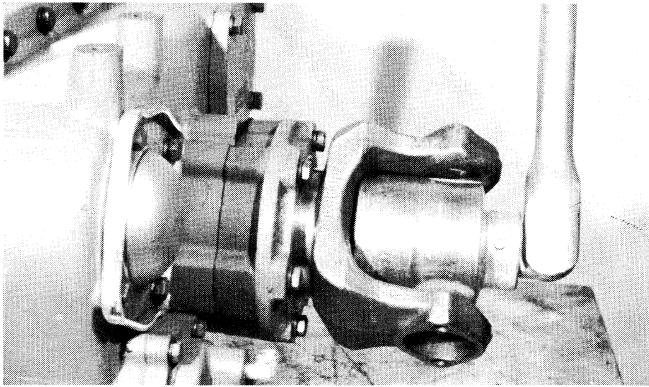

1. Turn the elastic stop nut from the output shaft.

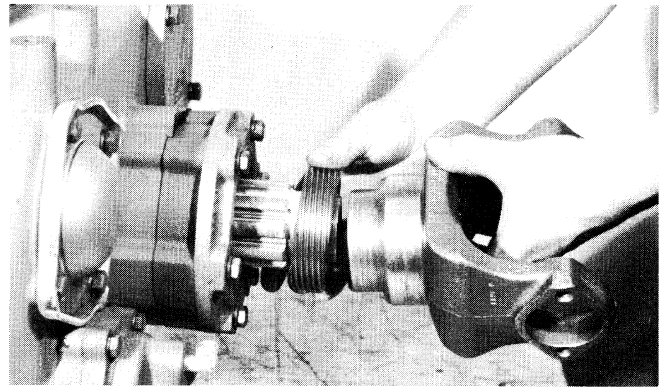

2. Pull the companion flange or yoke from the splines of the output shaft and remove the speedometer drive gear or spacer from the flange or yoke.

### C. Removal of the Auxiliary Rear Section

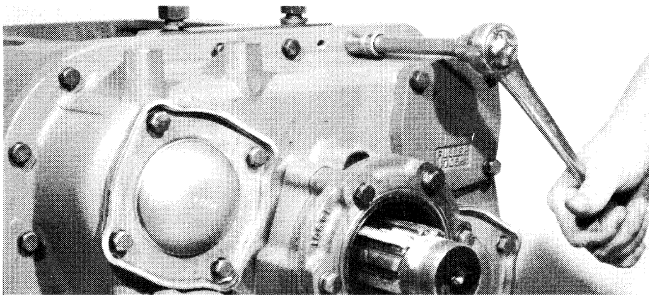

1. Turn out the 19 capscrews retaining the auxiliary section to the front case.

**NOTE:** With T-955AL and GL series transmissions, it may be necessary to remove the plate located at the top right corner of the auxiliary section to allow access to the top right retaining capscrews.

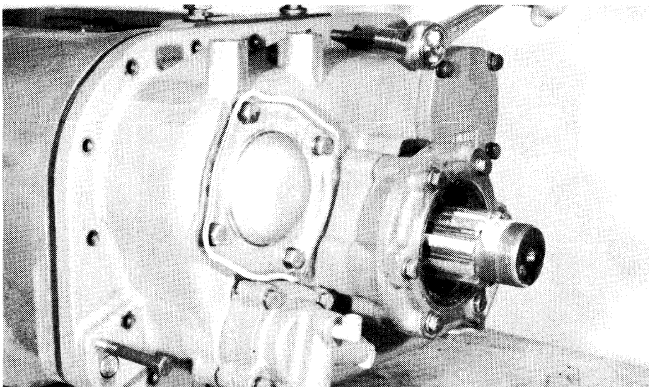

2. Insert three puller screws in the tapped holes in the flange of the auxiliary section and tighten evenly to break the gasket seal and move the rear section away from the front case. Move the rear housing back approximately  $\frac{1}{2}$ ".

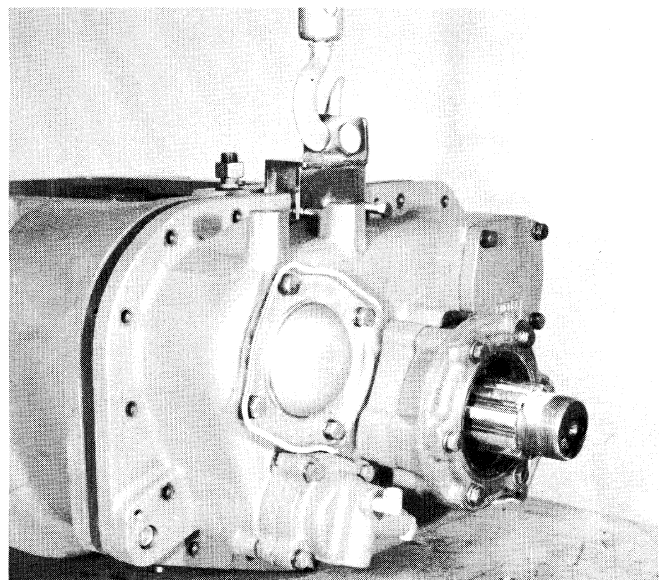

3. Remove the puller screws and attach a hanger bracket to the top of the rear housing. Use a chain hoist to move the rear housing off the front case dowel pins.

**NOTE:** It is advisable to re-install the elastic stop nut on the output shaft to avoid damage to the threads.

### III. Front Section

#### A. Removal and Disassembly of the Auxiliary Drive Gear Assembly

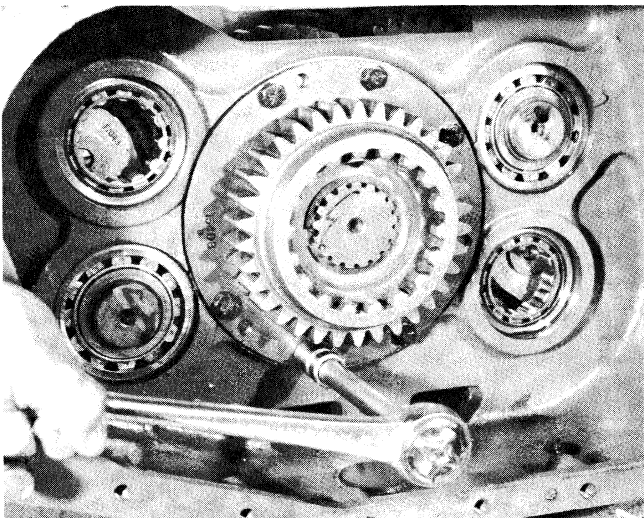
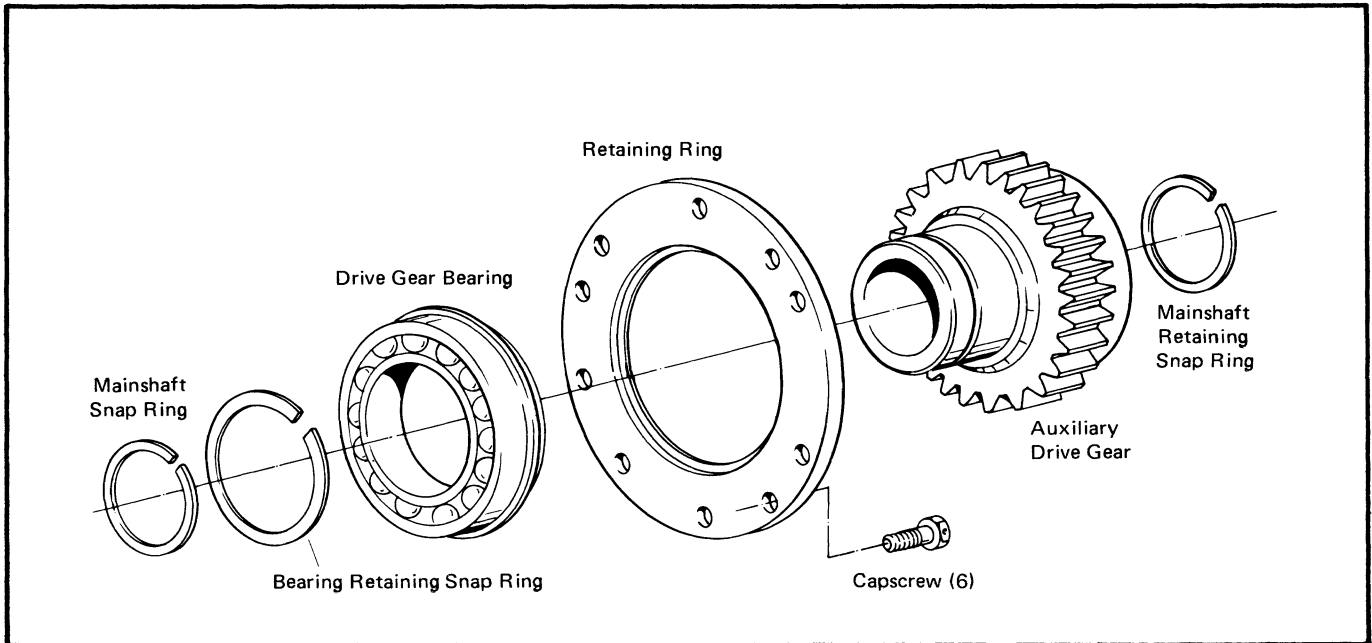

1. Cut the two lockwires and turn out the six capscrews retaining the auxiliary drive gear assembly to the front case.

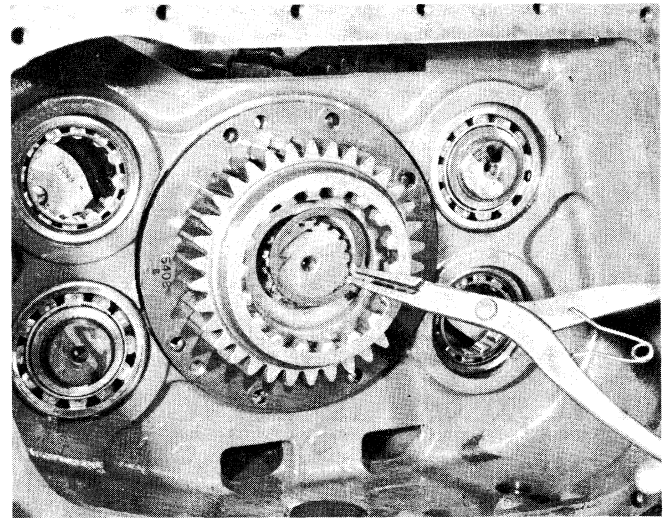

2. Remove the snap ring from the groove in the rear of the mainshaft.

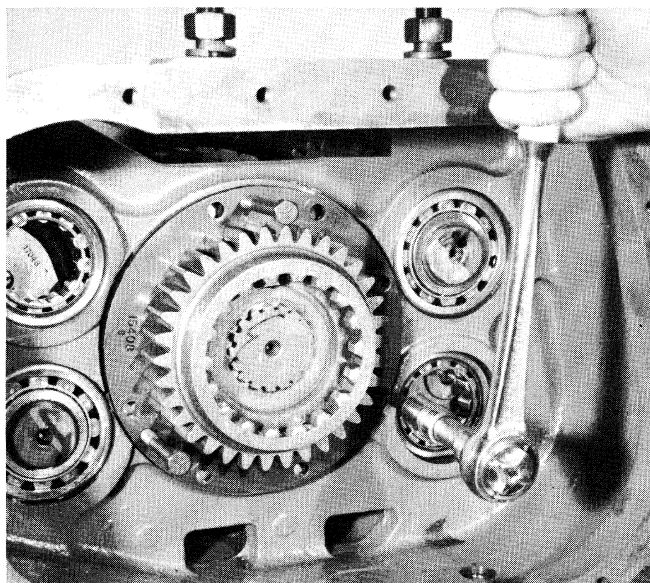

3. Insert three puller screws in the tapped holes of the retaining ring and tighten evenly to move the assembly to the rear and from the case bore.

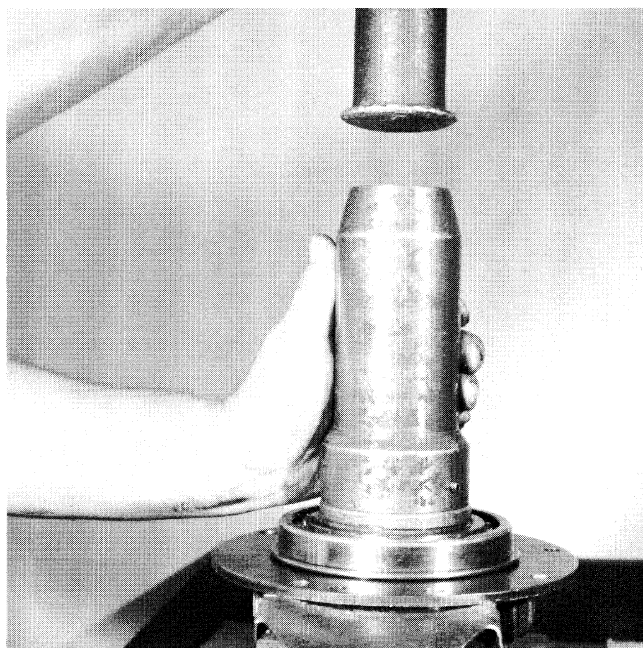

5. Support the assembly in a vise by the retaining ring and use a mallet and driver to drive the gear down and from the bearing. This will free the retaining ring.

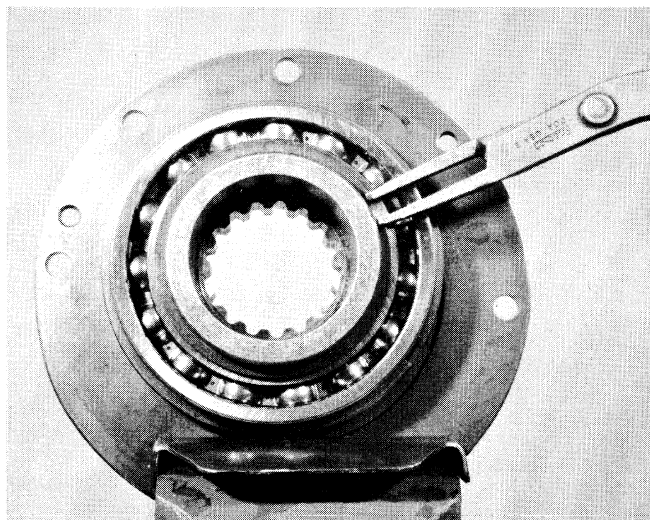

4. Remove the snap ring from the groove on the front of the auxiliary drive gear.

B. Removal of the Left Reverse Idler Gear Assembly

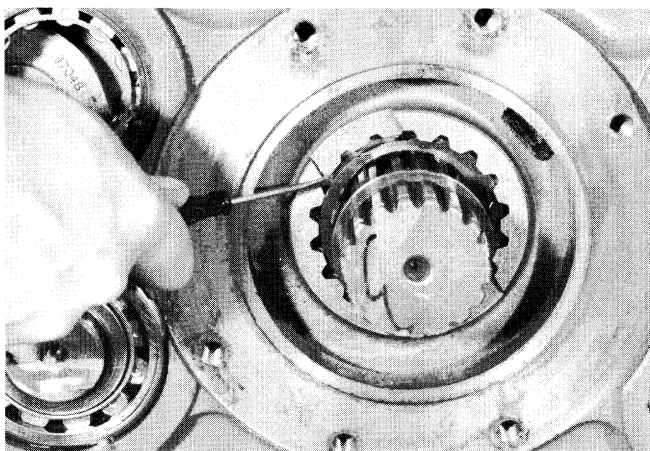
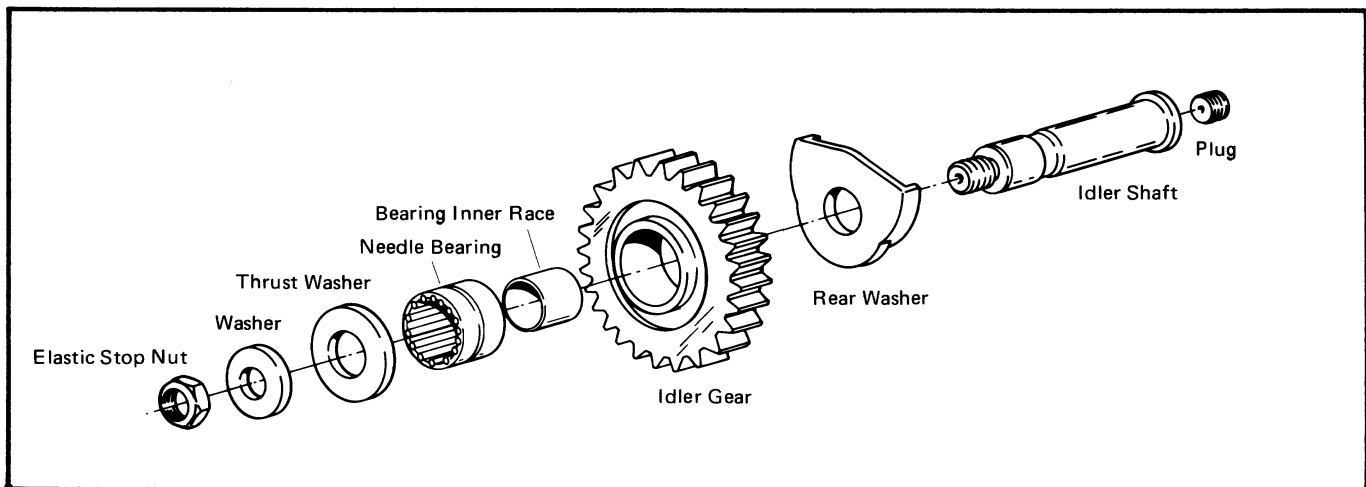

1. Remove the snap ring from the ID of the hub of the mainshaft reverse gear.

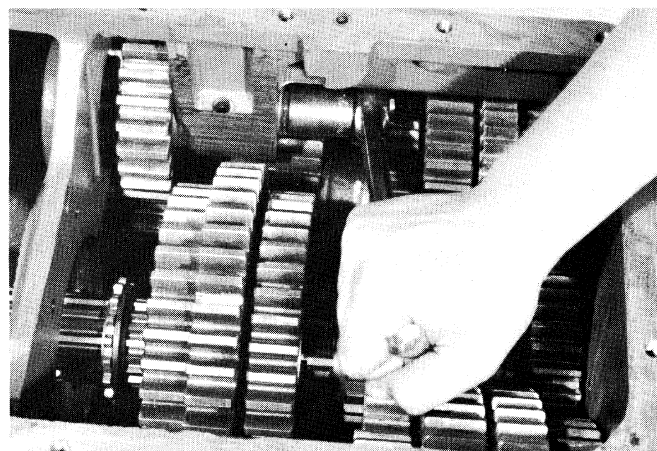

3. Remove the elastic stop nut and washer from the end of the idler shaft.

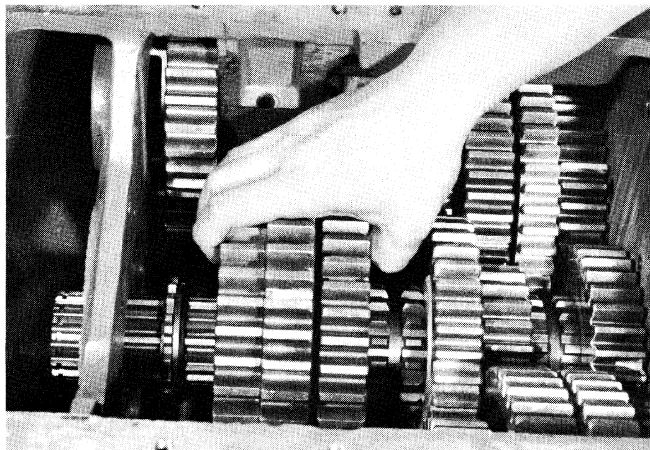

2. Move the reverse gear forward on the mainshaft and against the 1st speed gear, engaging the splines of both the reverse and 1st speed gears with the splines of the sliding clutch gear.

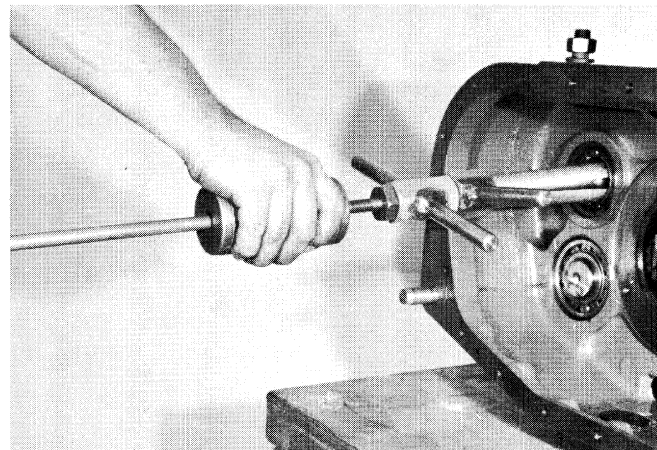

4. Use inside jaw pullers to remove the left auxiliary countershaft front bearing from the case bore. The right auxiliary countershaft front bearing may also be removed at this time.

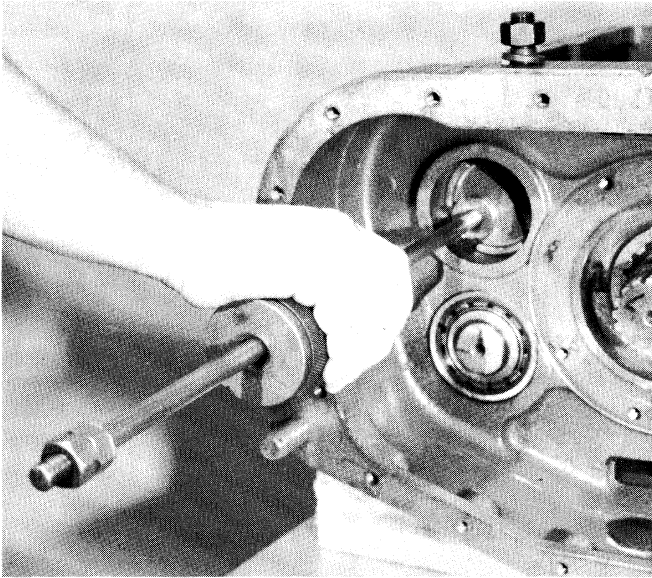

5. Remove the plug from the end of the idler shaft and insert an impact puller in the tapped hole. Hold the gear and thrust washer in place inside the case and pull the idler shaft to the rear and from the case.

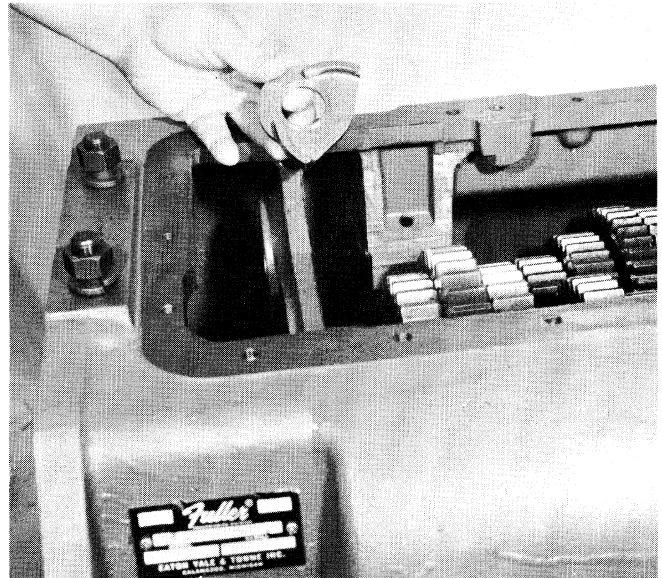

7. Remove the idler rear washer from the case.

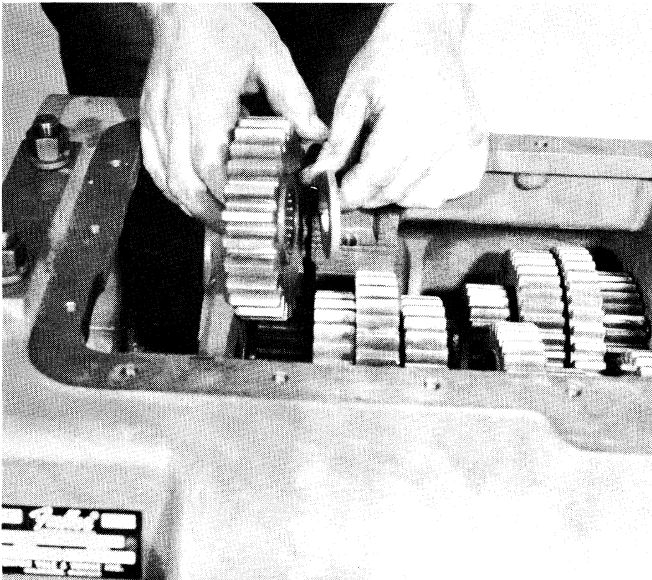

6. Remove the gear and thrust washer from the case.

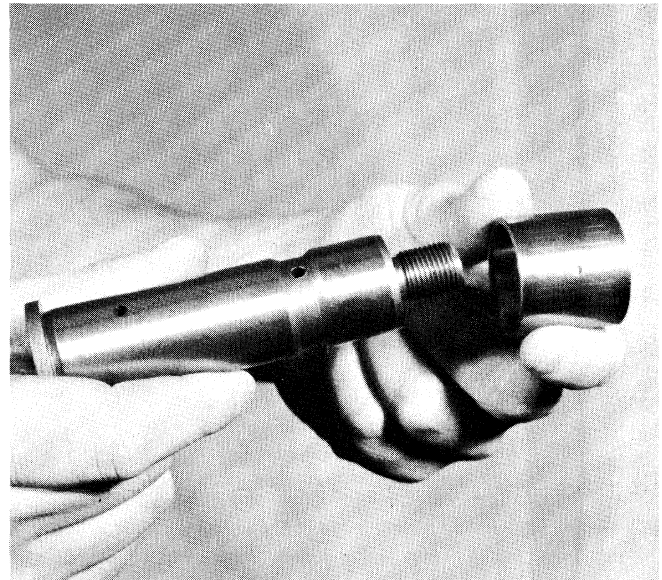

8. Remove the bearing inner race from the idler gear. If necessary, press the bearing from the gear.

C. Removal of the Right Countershaft Bearings

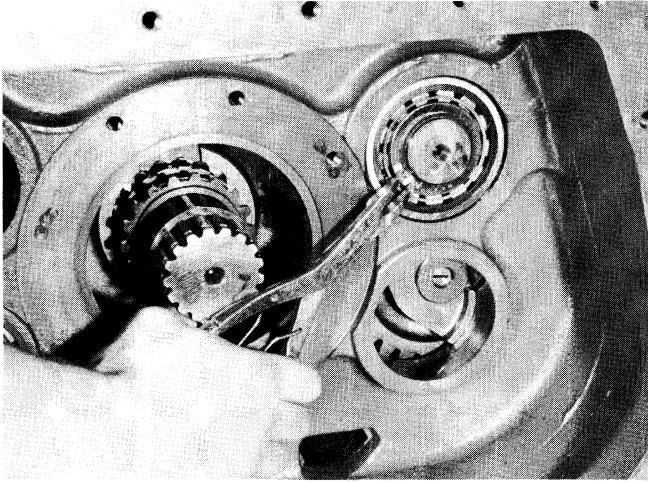

1. Remove the snap ring from the groove in the rear of the right countershaft.



2. Use a mallet and punch or other similar pointed instrument against the inner race of the bearing to drive the bearing to the rear and from the case bore and countershaft.

**NOTE:** Removal of the countershaft rear bearings will generally result in damage to the bearings and should not be attempted unless replacement of the bearings is planned.

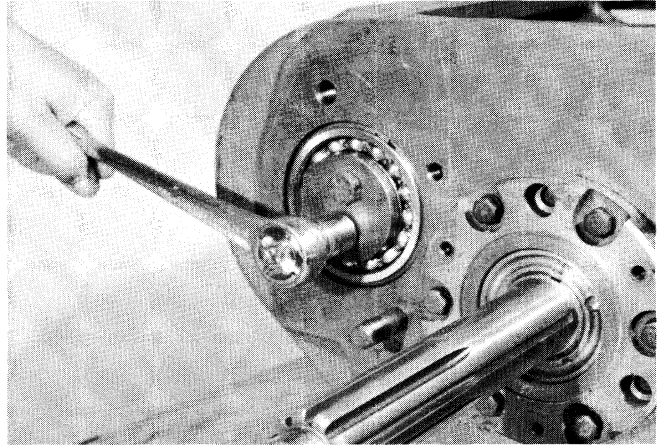

3. Cut the lockwire, turn out the two lock screws and remove the front bearing retaining plate. It may be necessary to lock the transmission in two speeds to remove the lock screws.

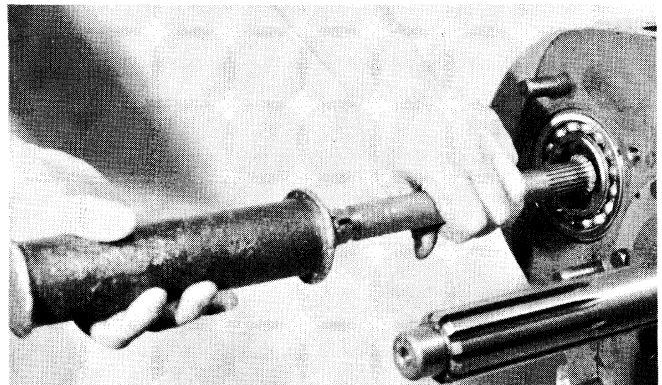

4. Use a soft bar and mallet to drive the countershaft as far as possible to the rear.

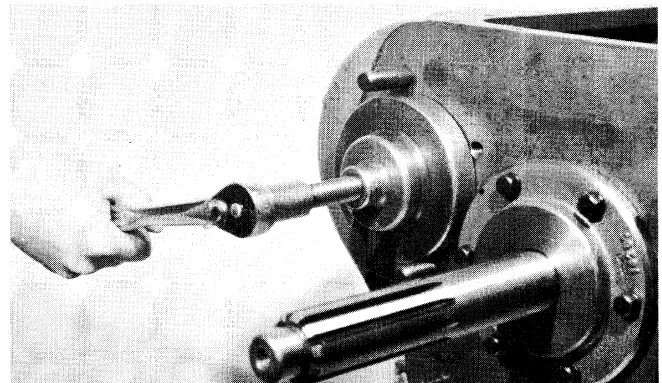

5. Use a soft bar and mallet on the rear of the countershaft to drive the shaft as far forward as possible. This will unseat the front bearing from the case bore. Use a bearing puller to remove the bearing from the countershaft.

D. Removal and Disassembly of the Mainshaft Assembly

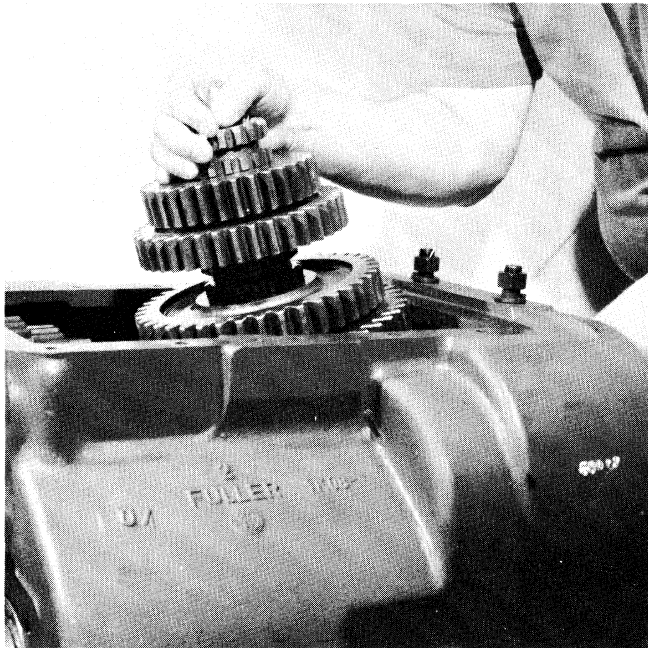
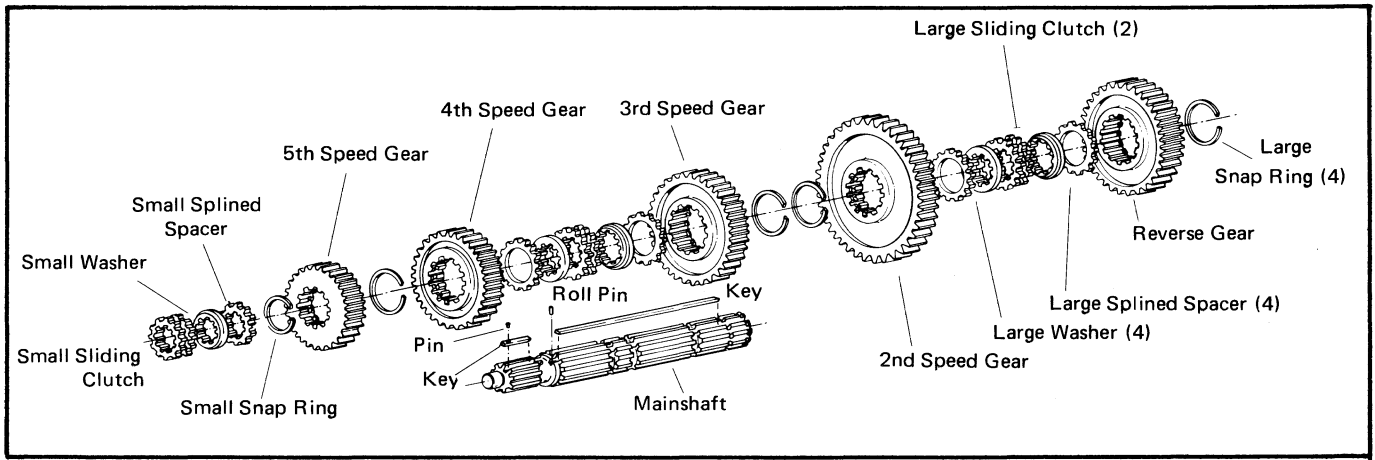

1. Block the right countershaft against the side of the case and pull the mainshaft as far to the rear as possible. Tilt the front of the mainshaft up, move the assembly forward and lift the mainshaft from the case, working the gears on the mainshaft past the gears on the countershaft. Use caution as the reverse gear is free and can fall from the mainshaft.

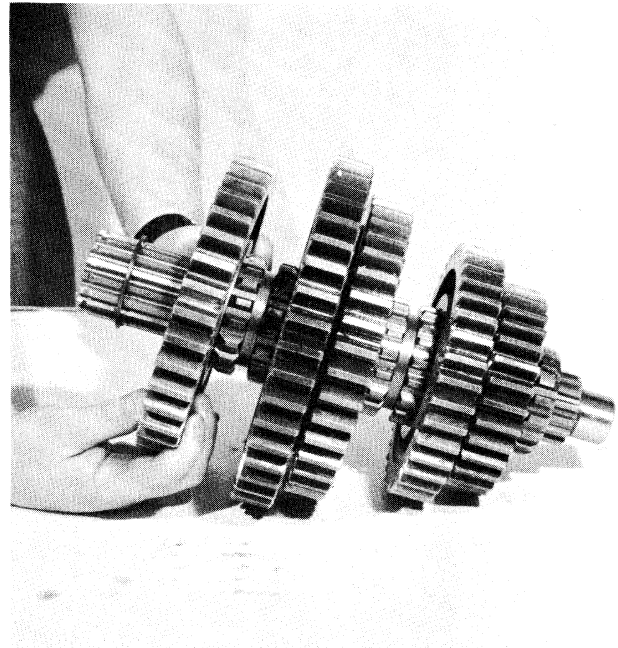

2. Place the mainshaft on a workbench and remove the reverse gear.



**D. Removal and Disassembly of the Mainshaft Assembly — continued**

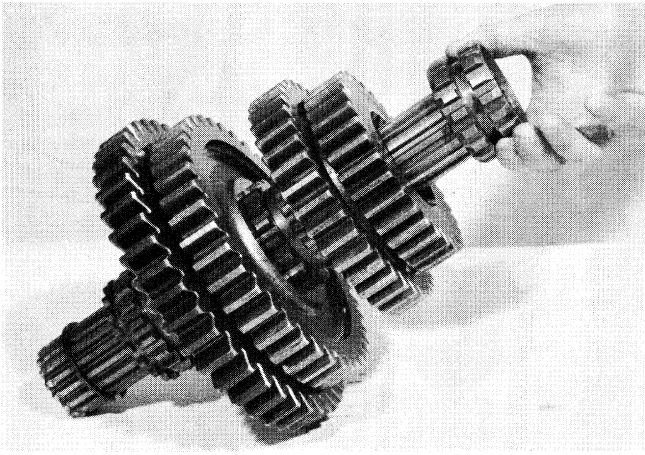

**3. Remove the 5th-6th speed sliding clutch from the front of the mainshaft.**

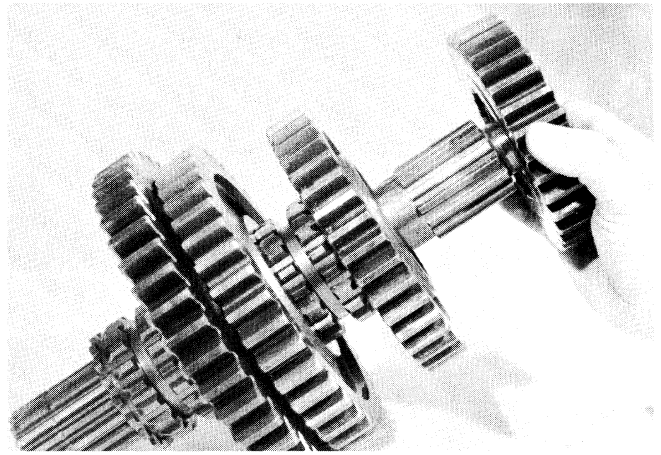

**6. Remove the 5th speed gear, spacer and washer from the mainshaft.**

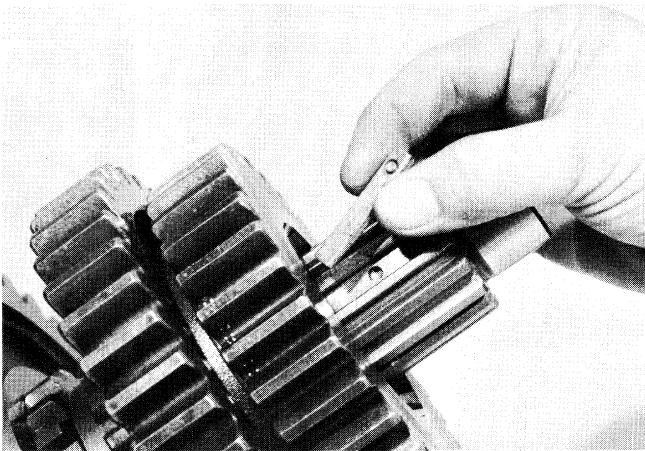

**4. Remove the key located under the 5th-6th speed sliding clutch.**

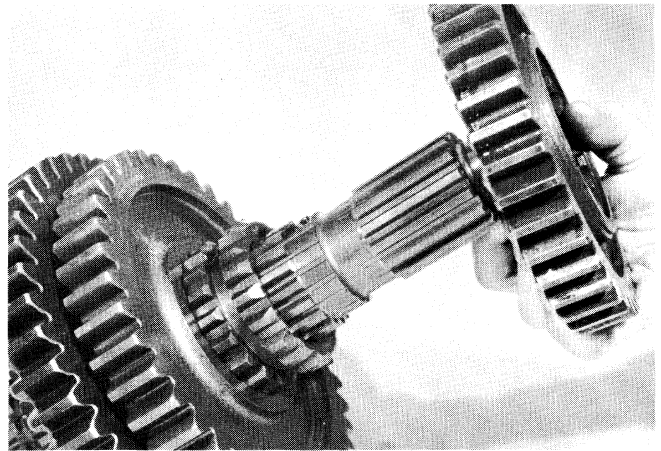

**7. Remove the 4th speed gear, spacer and washer from the mainshaft.**

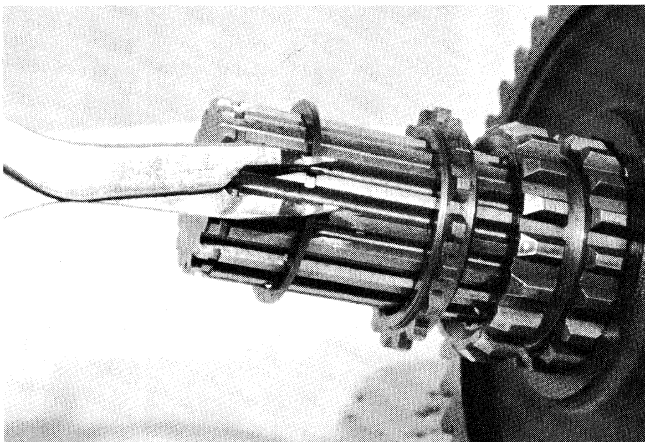

**5. Remove the snap ring from the groove in the rear of the mainshaft.**

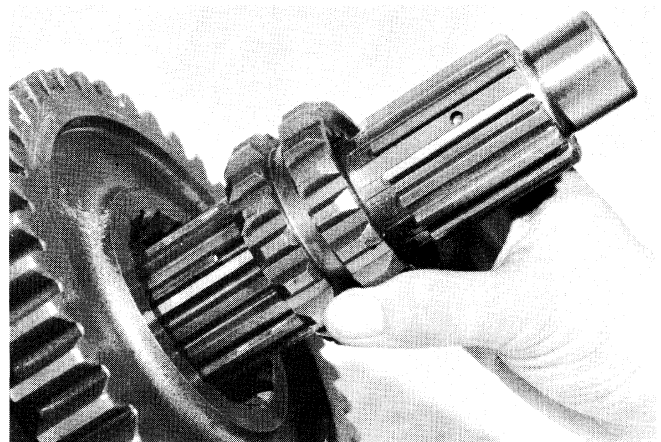

**8. Pull the 3rd-4th speed sliding clutch from the splines of the mainshaft.**

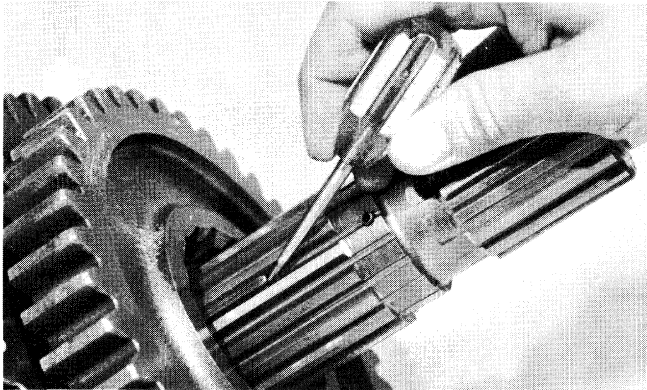

9. Use a pointed object to push the key down the mainshaft until the other end extends beyond the mainshaft.

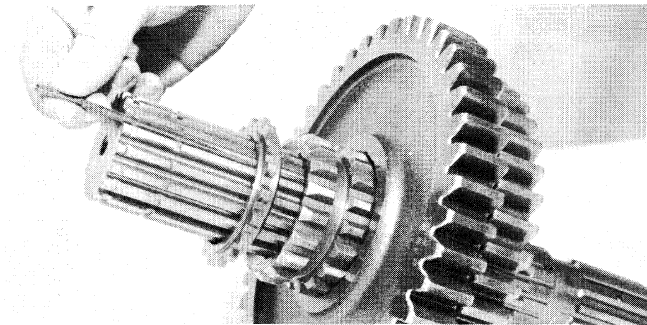

10. Pull the key from the keyway.

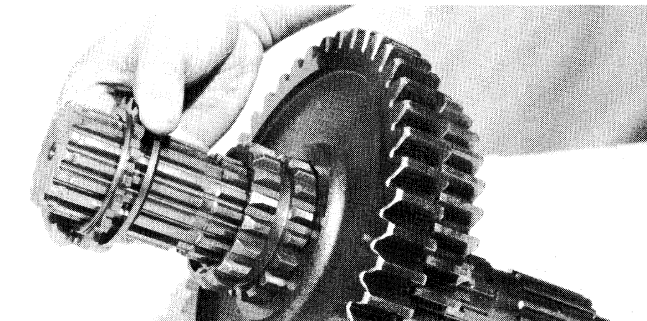

11. Remove the reverse gear washer and spacer from the mainshaft.

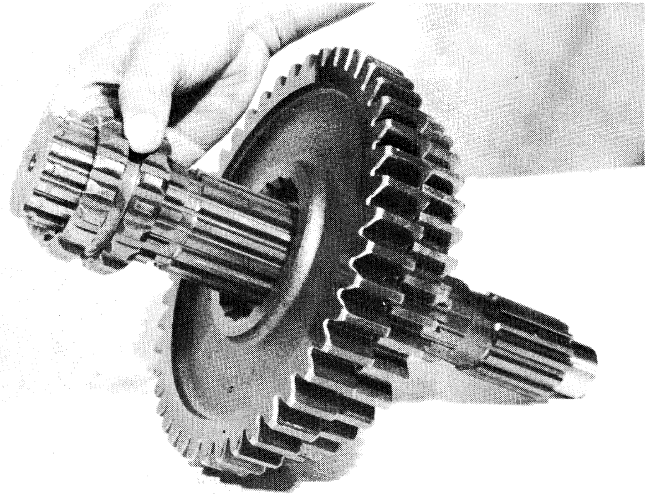

12. Pull the reverse-2nd speed sliding clutch from the splines of the mainshaft.

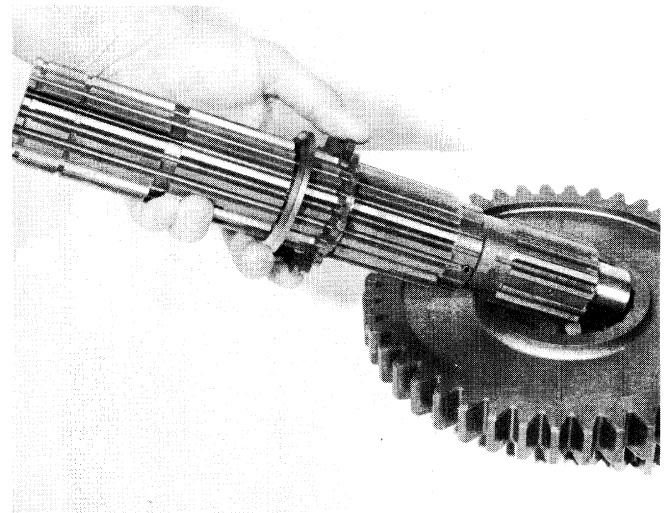

13. Remove the second and third speed gears, washers and spacers from the mainshaft.

## E. Removal of the Left Countershaft Bearings

1. See page 28 as removal procedures for both sets of countershaft bearings are identical.

**F. Removal and Disassembly of the Input Shaft and Drive Gear Assembly**

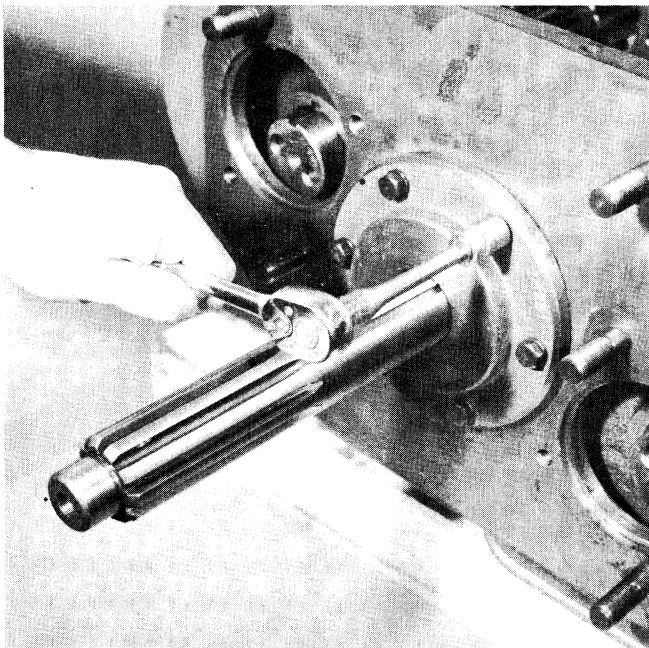
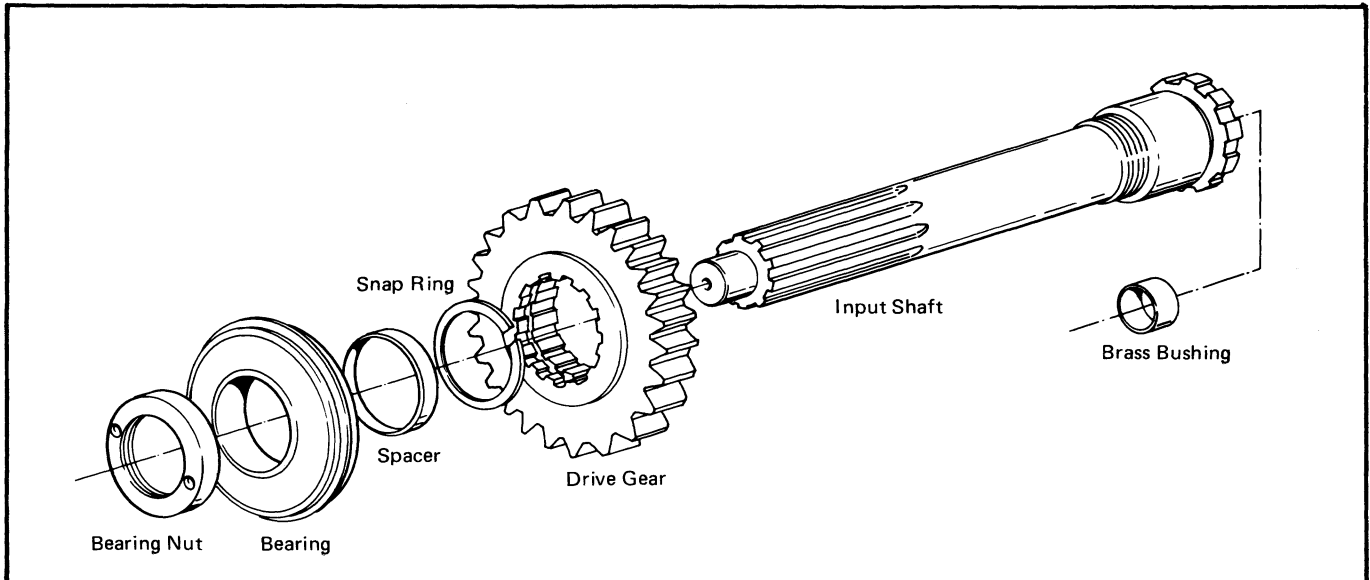

**1. Turn out the retaining cap screws and remove the front bearing cover.**

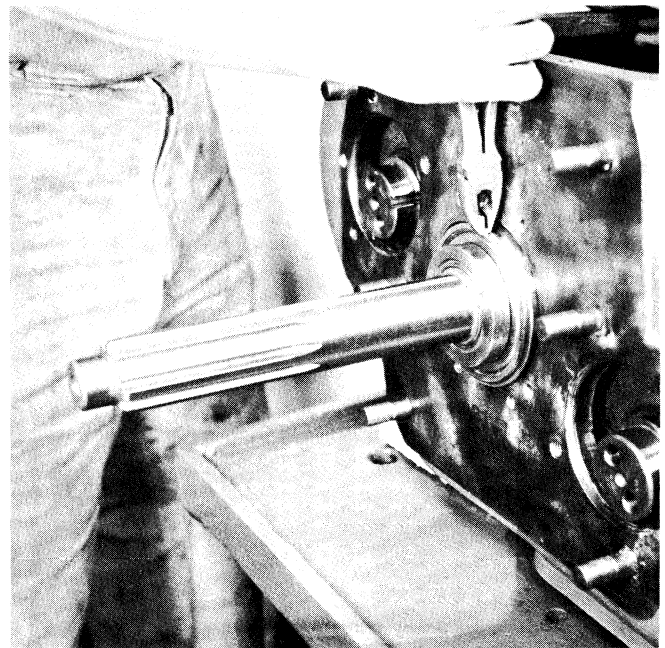

**2. From inside the case, tap the drive gear forward so that the snap ring can be removed from the bearing. Use a soft bar and mallet to move the drive gear forward if necessary.**

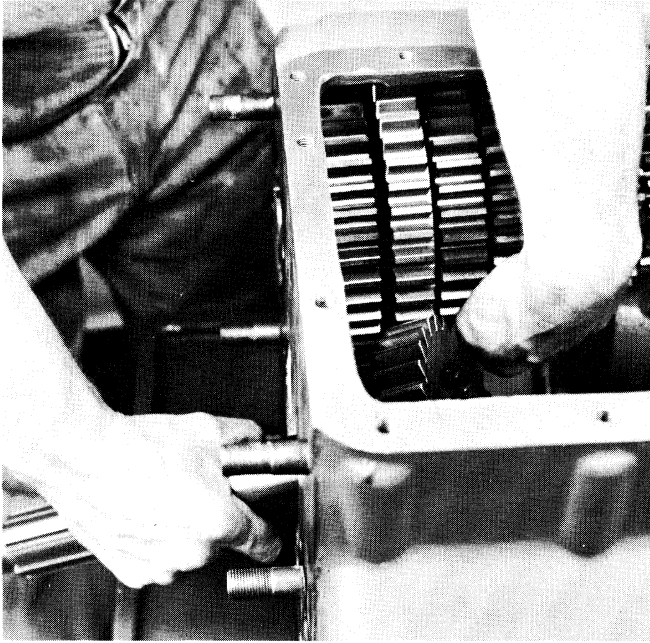

3. Move the drive gear assembly to the inside of the case, working past the countershaft assemblies. Remove the drive gear assembly from the case.

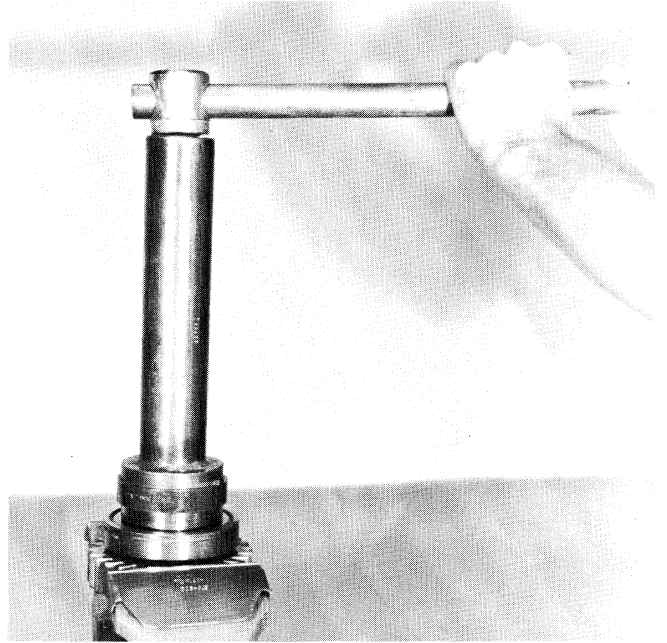

5. Turn the bearing nut from the shaft (left hand thread.)

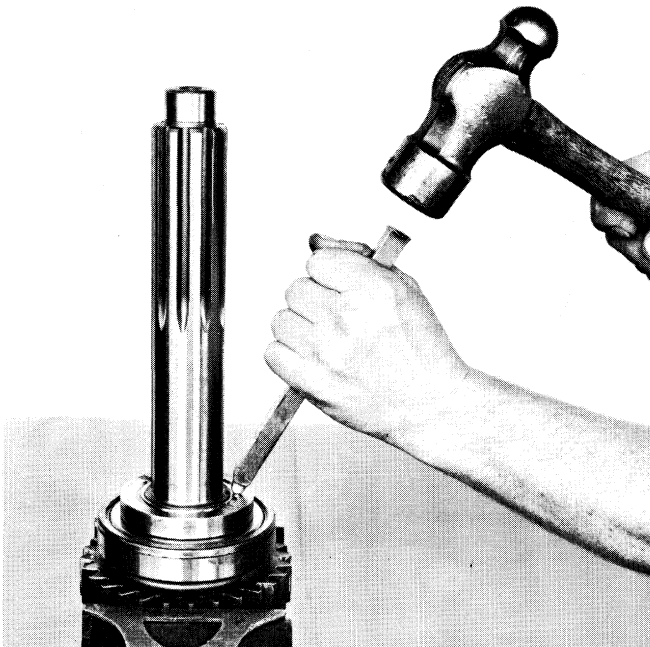

4. Relieve the bearing nut where it is peened into the shaft.

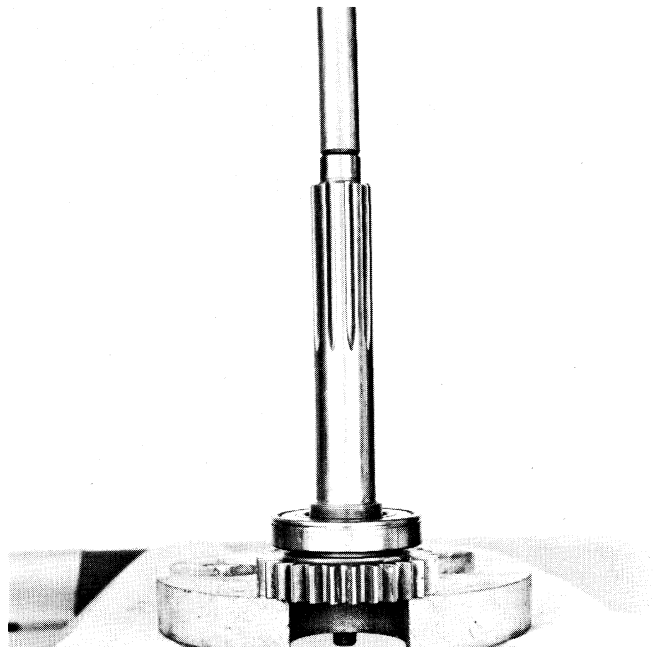

6. Press the shaft through the bearing and gear. If necessary, remove the snap ring from the ID of the gear. Check the bushing in the pocket of the input shaft; replace if damaged.

G. Removal and Disassembly of the Countershaft Assemblies

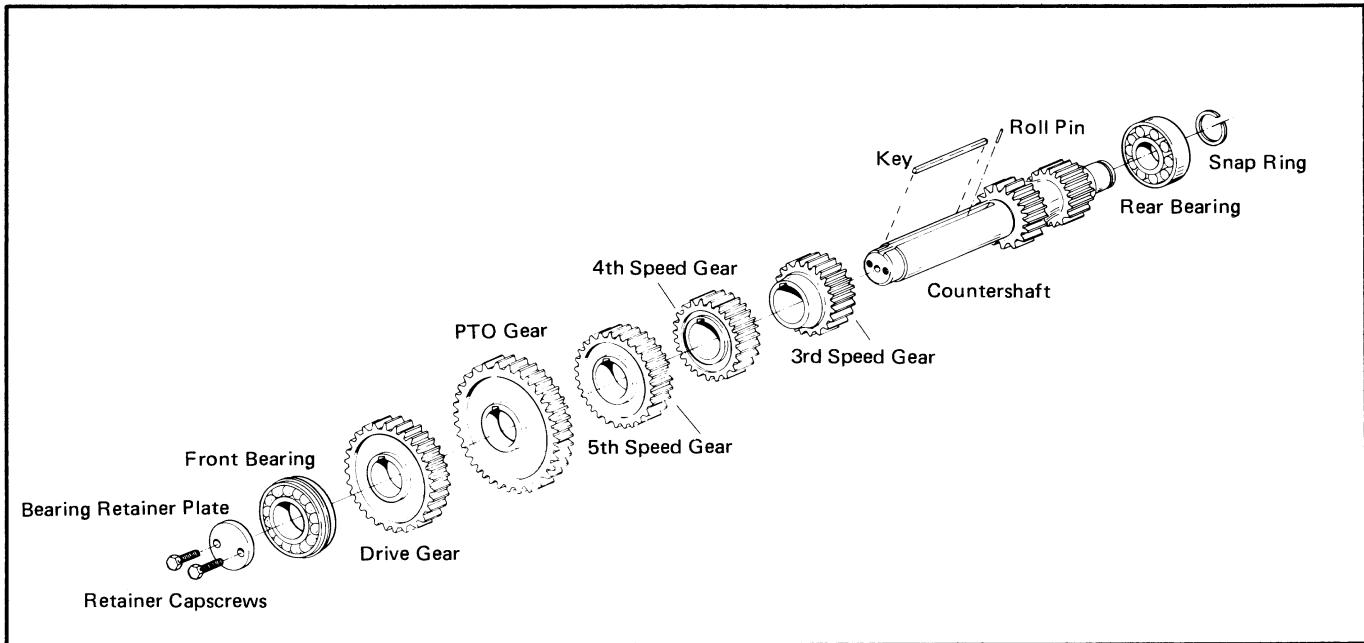

1. Remove the right and left countershaft assemblies from the case.

**NOTE:** Except for the number of teeth on the PTO gears, the countershaft assemblies are identical and disassembled in the same manner.

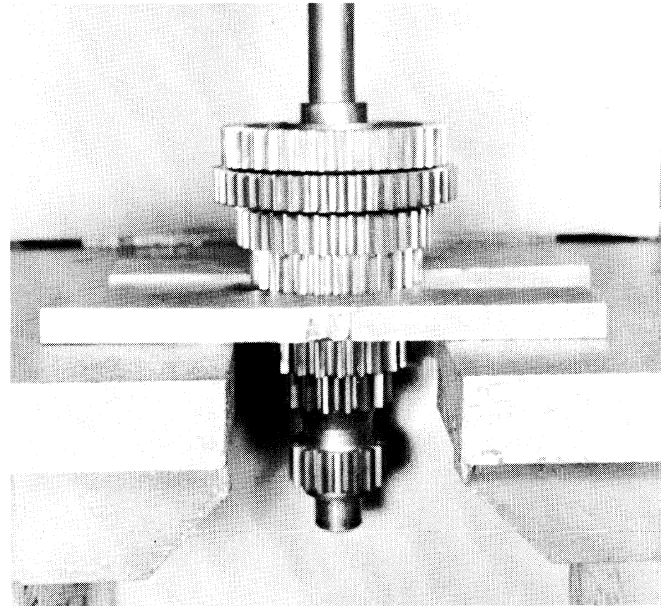

2. Press the 6th, PTO, 5th and 4th speed gears from the countershaft. (This will require a press of at least 25-ton capacity; use metal shield as a safety precaution.)

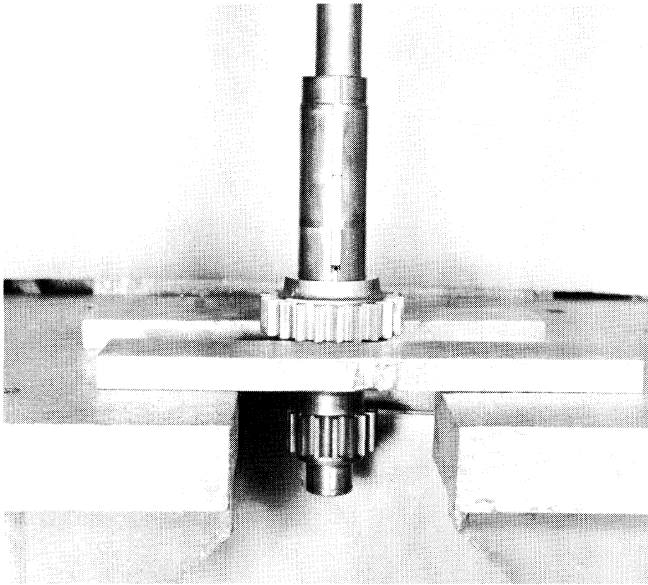

**IMPORTANT:** Never use the PTO gear as a base for pressing as the larger diameter of this gear makes it susceptible to breakage.

3. Press the 3rd speed gear from the shaft. If necessary, remove the key and roll pin from the shaft.

#### H. Removal and Disassembly of the Right Reverse Idler Gear Assembly

1. Refer to page 26 as the right and left reverse idler gear assemblies are identical and are disassembled in the same manner.

## IV. Auxiliary Section

### T-955AL, T-955GL, Models

#### A. Removal of the First-Reverse Speed Sliding Clutch Gear

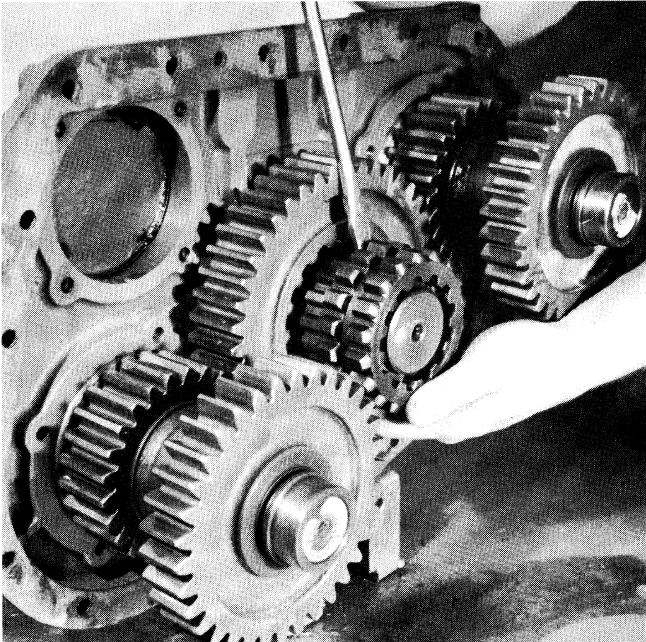

1. Insert a large screwdriver between the sliding clutch gear and the 1st speed gear and pry the sliding clutch forward and off the splines of the output shaft.

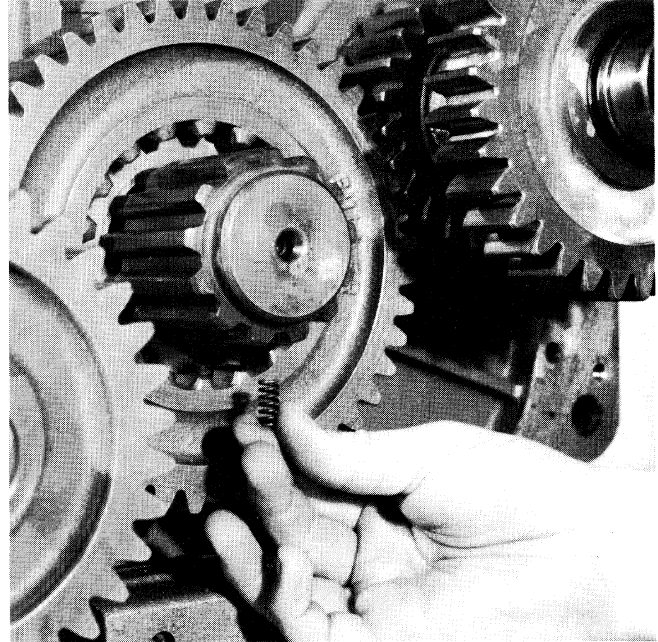

3. Rotate the output shaft until the tension spring falls from the bore in the shaft.



2. Remove the tension ball from the bore in the output shaft.

**B. Removal of the Auxiliary Countershaft Assemblies**

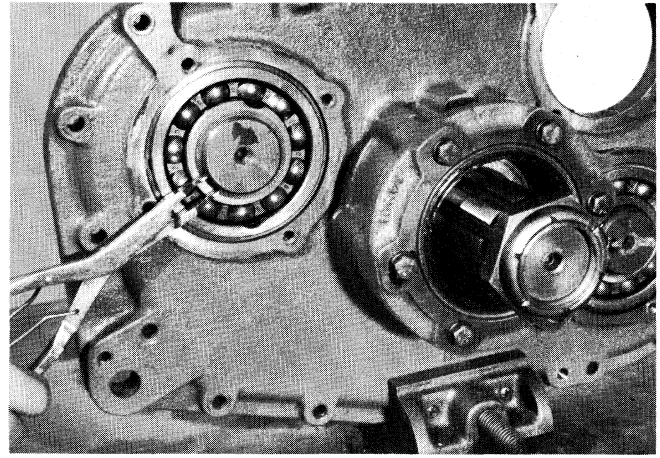
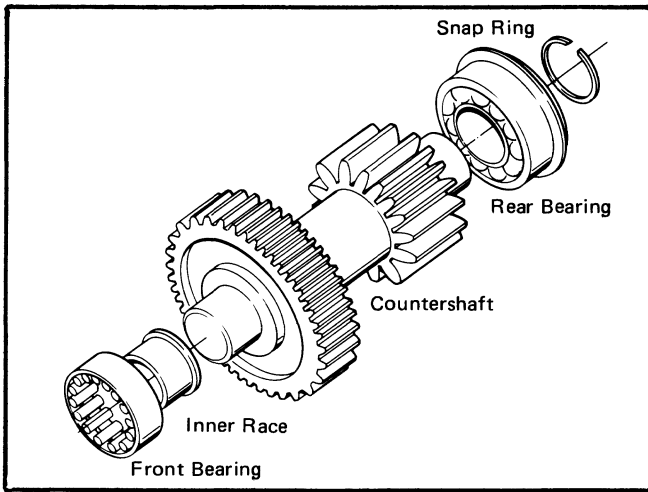

3. Remove the snap ring from the rear of each auxiliary countershaft.

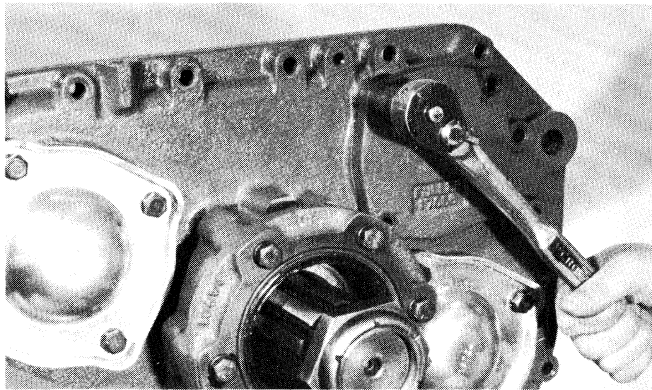

1. If not previously removed, turn out the retaining cap screws and remove the rear cover.

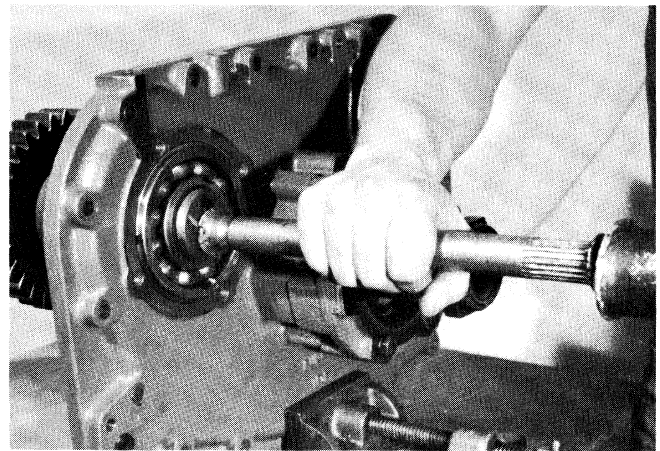

4. Use a soft bar and mallet to drive the countershafts forward and from the rear bearings. If necessary, remove the bearing inner race from the front of each shaft.

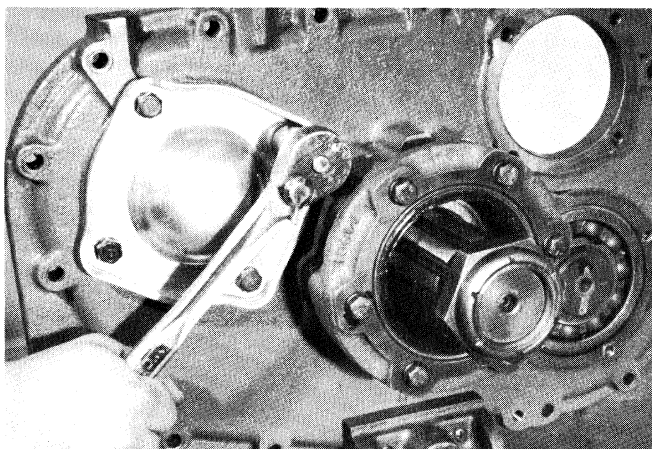

2. Turn out the cap screws and remove the two rear bearing covers.

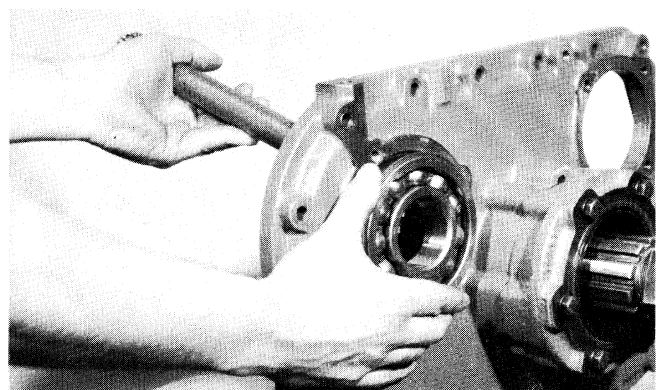

5. Use a soft bar to tap the bearings to the rear and from the housing bores. Tap on the outer race to avoid damage to the bearings.



C. Removal of the First Speed Gear, Output Shaft and Rear Bearing Assembly

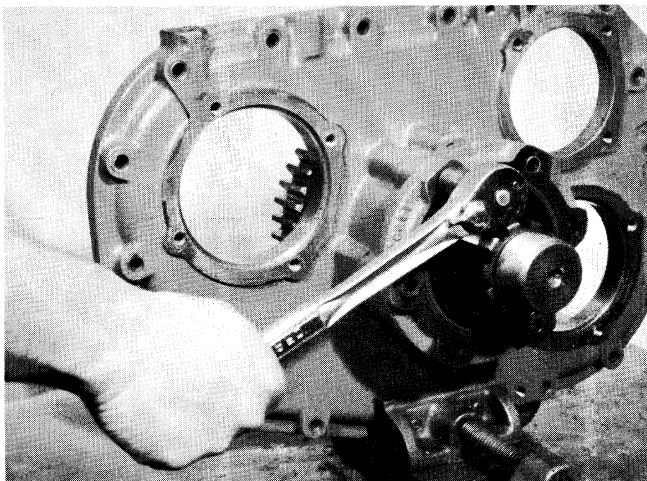
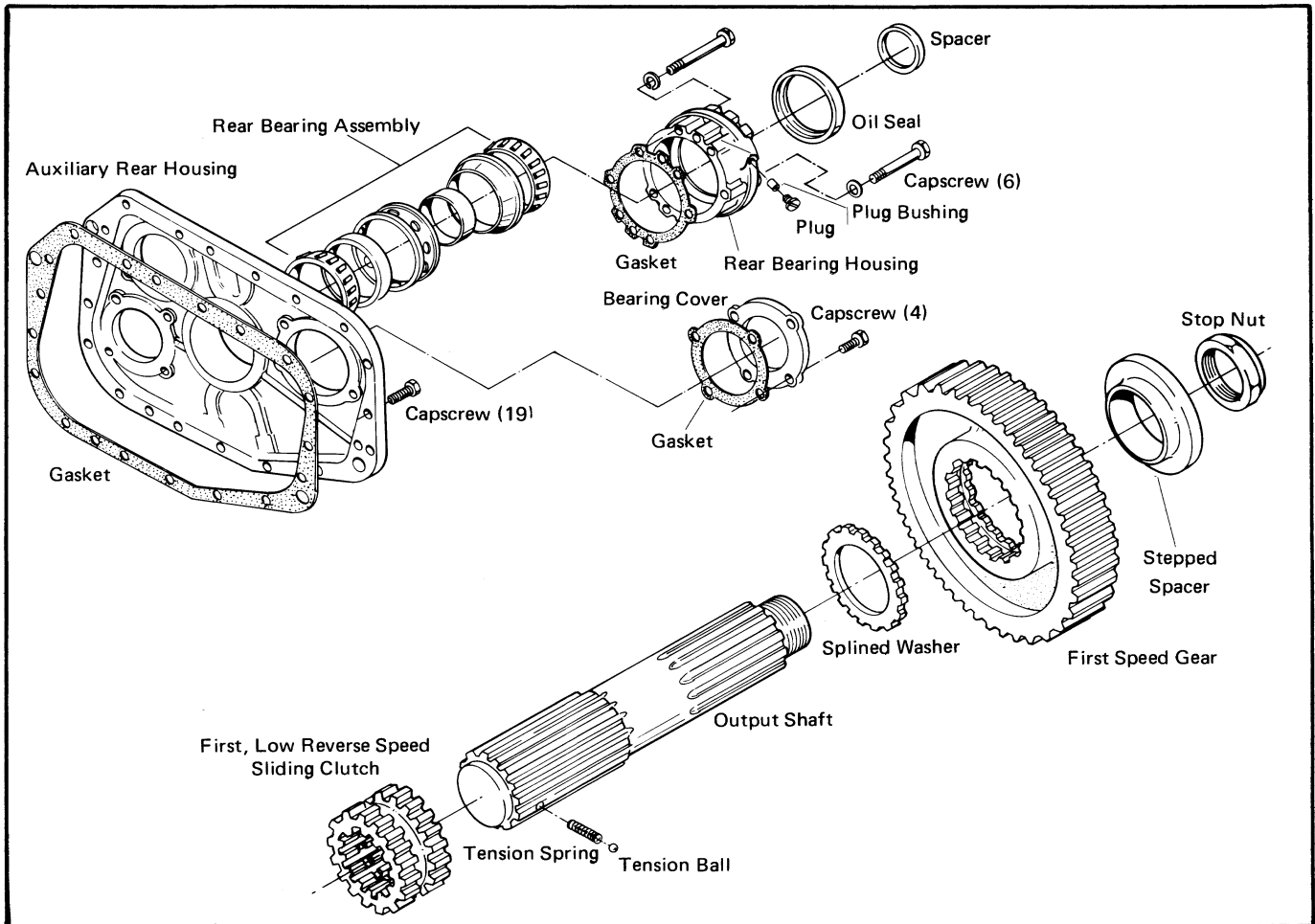

1. Turn out the six retaining cap screws and remove the rear bearing housing. If necessary, remove the oil seal from the housing.

**NOTE:** The oil seal will most likely be damaged during removal and should not be removed unless replacement of the seal is planned.

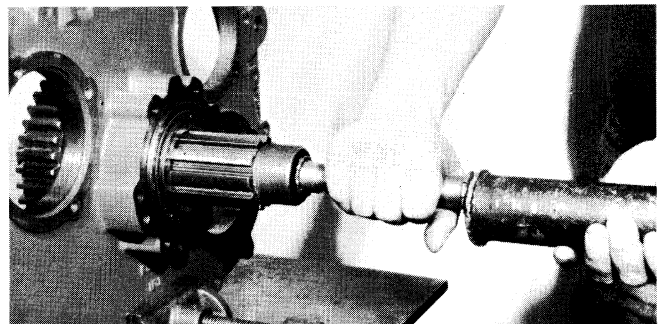

2. Use a soft bar and mallet to drive the output shaft forward and from the rear bearing assembly.

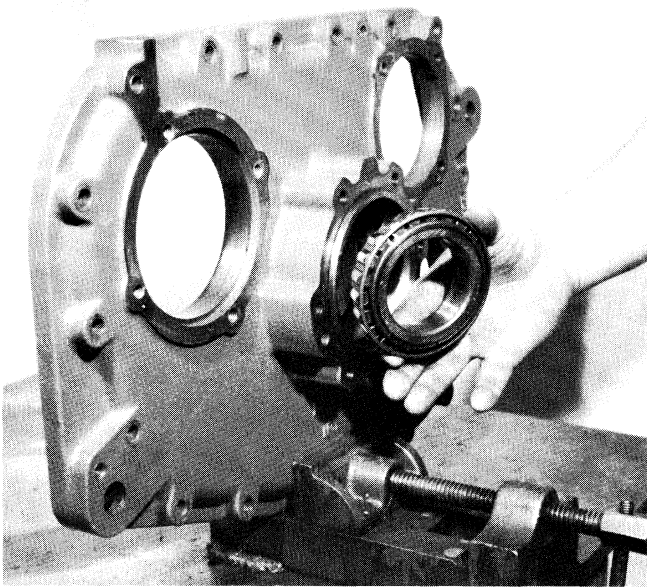

3. Remove the rear bearing cone from the rear housing.

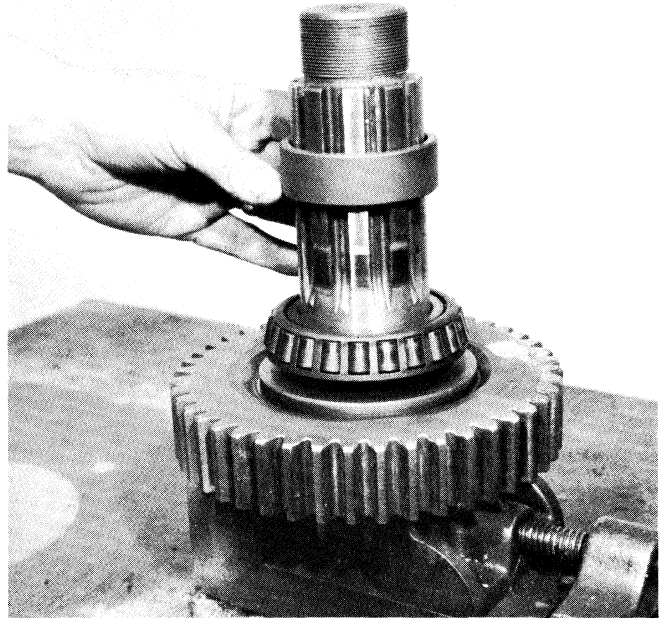

5. Place the output shaft on end and remove the bearing inner spacer.

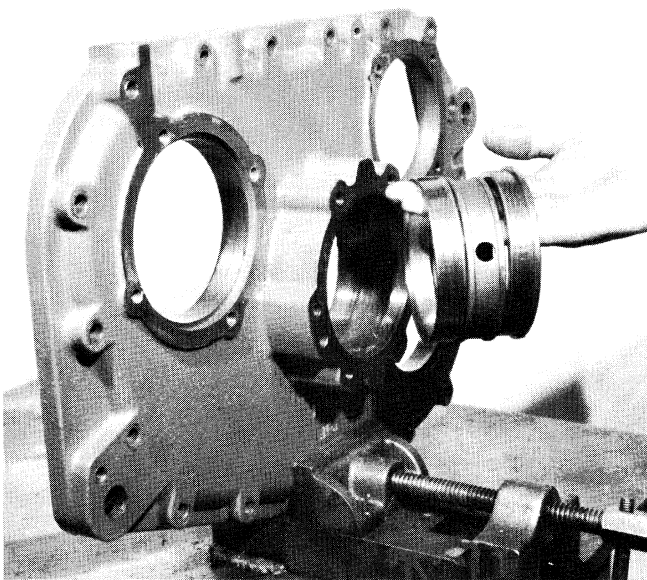

4. Use a soft bar to tap the two bearing cups and outer spacer from the bore in the rear housing.

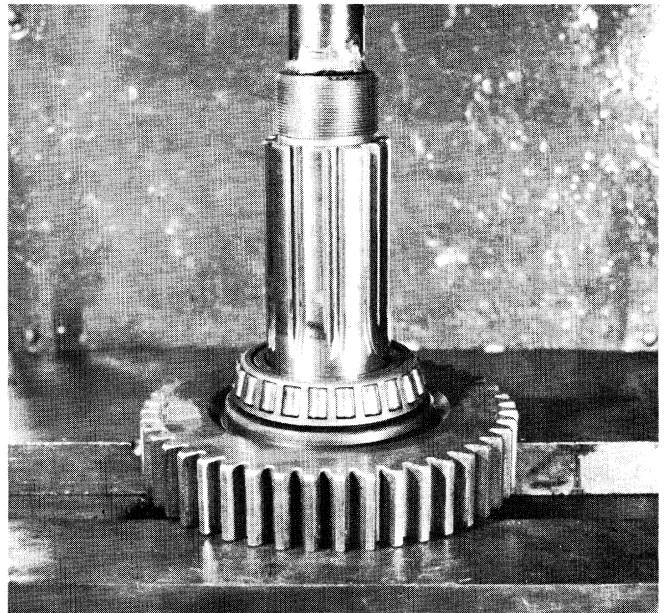

6. Using the first speed gear as a base, press the front bearing cone from the output shaft. This will free the bearing, gear, washer and spacer.

## V. Auxiliary Section

### T-955ALL, Models

#### A. Removal of the Auxiliary Countershafts

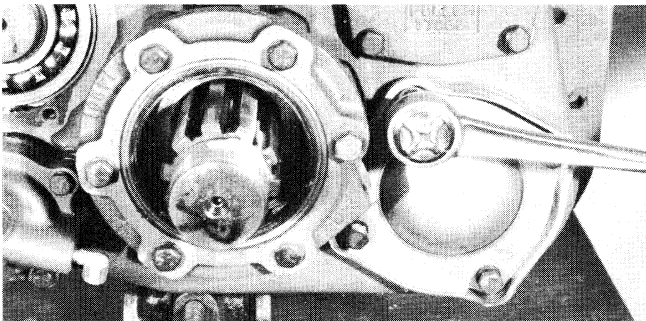
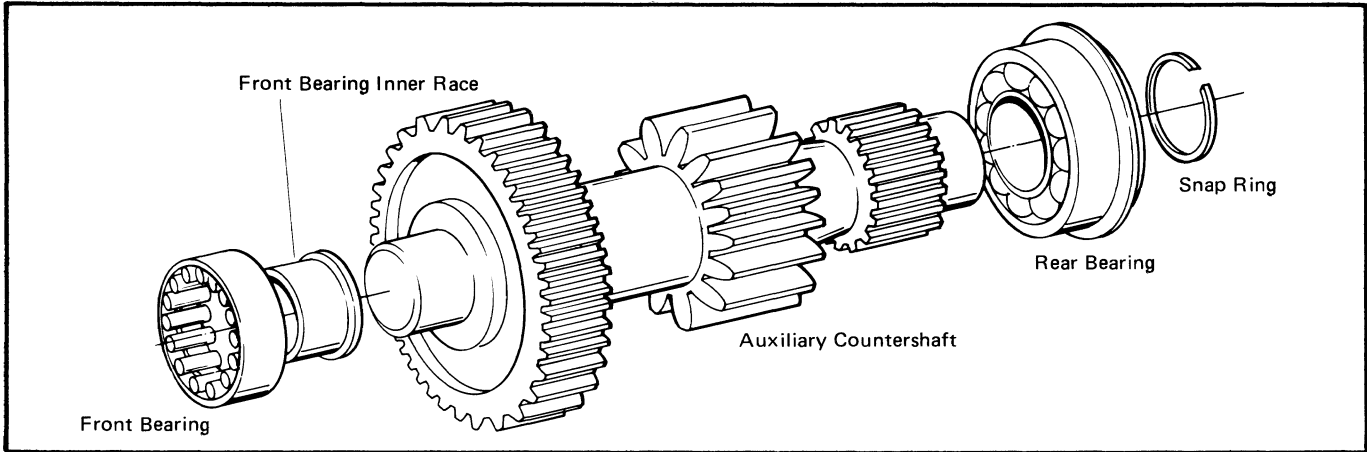

1. Mount the auxiliary section in a vise in the upright position, turn out the attaching capscrews and remove the two rear bearing covers.

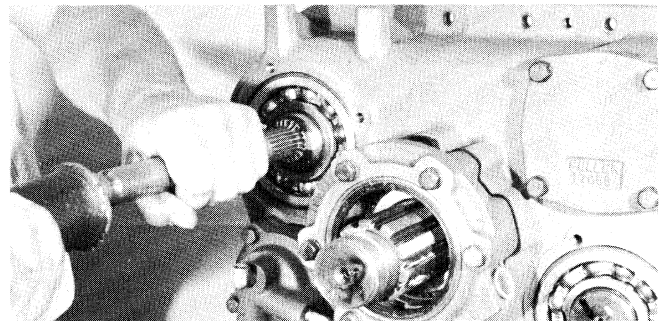

3. Use a soft bar and mallet to drive the countershafts forward and from the rear bearings. If necessary, remove the bearing inner race from the front of each shaft.

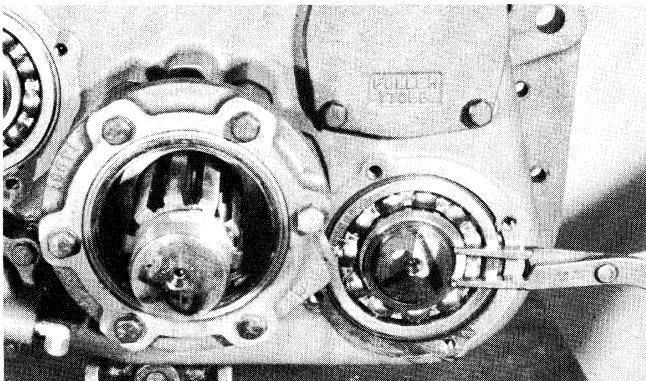

2. Remove the snap ring from the rear of each countershaft.

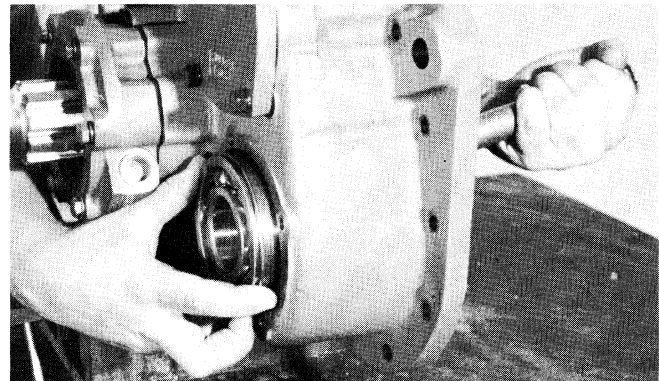

4. Use a soft bar to tap the bearings to the rear and from the case bores. Tap on the outer race to avoid damage to the bearings.

**B. Removal of the Sliding Clutch and First Speed Gear**

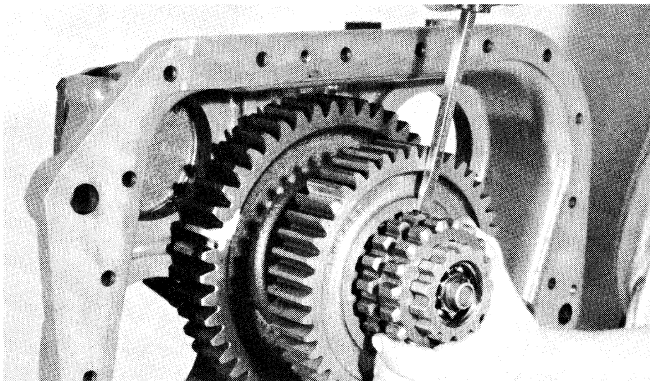
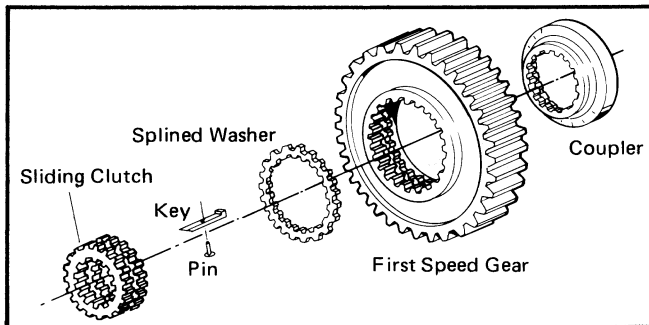

1. Pry the sliding clutch forward and off the splines of the range mainshaft.

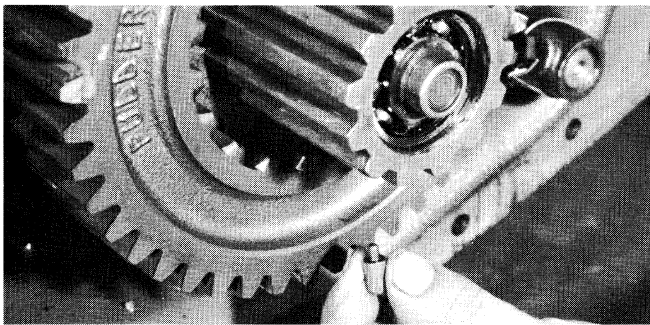

2. Rotate the mainshaft until the sliding clutch retaining plunger falls from the bore in the shaft.

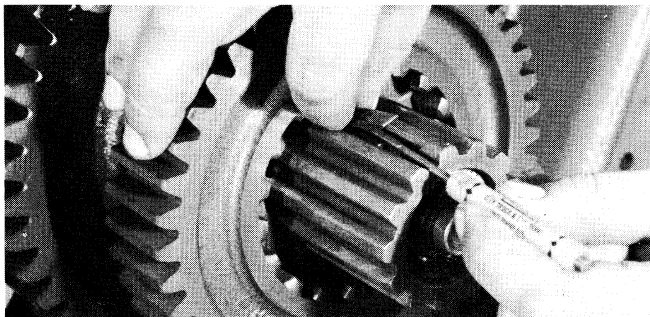

3. Remove the key from the groove in the mainshaft.

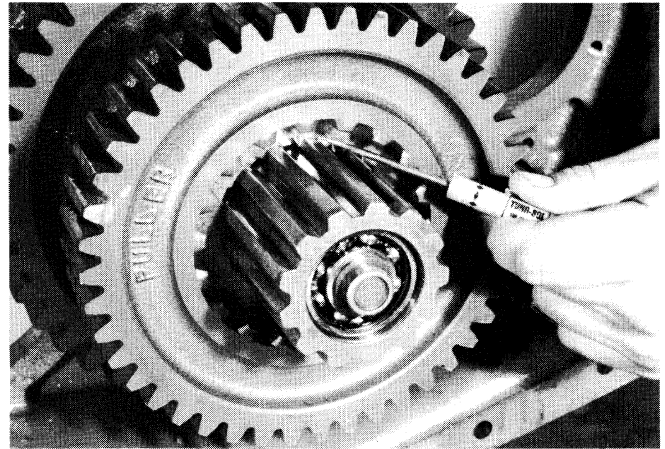

4. Turn the splined washer inside the 1st speed gear until the teeth align with the grooves in mainshaft, freeing the gear.

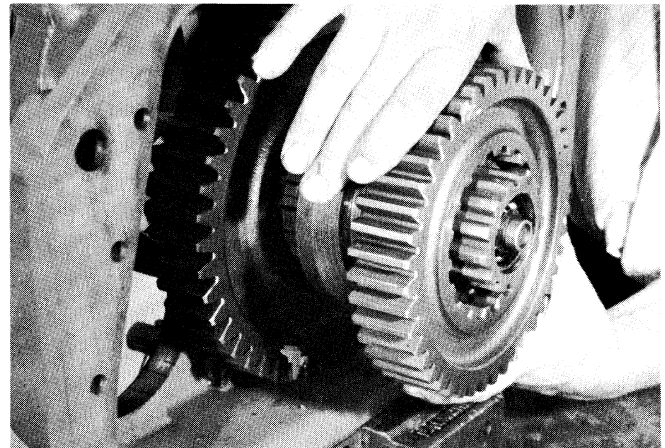

5. Pull the 1st speed gear from the splines of the mainshaft.

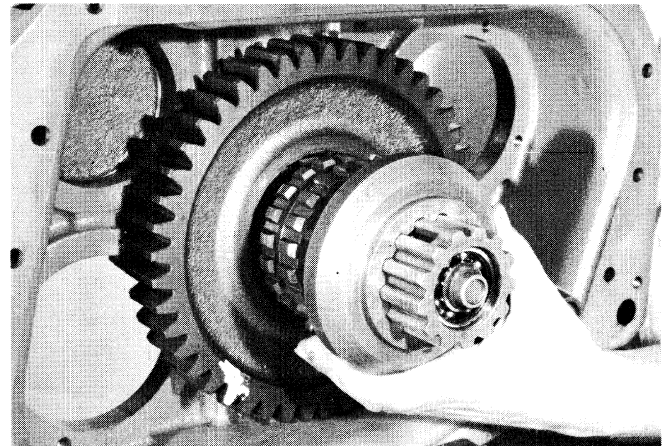

6. Remove the coupler from the splines of the mainshaft.

C. Removal and Disassembly of the Low Gear Shift Cylinder

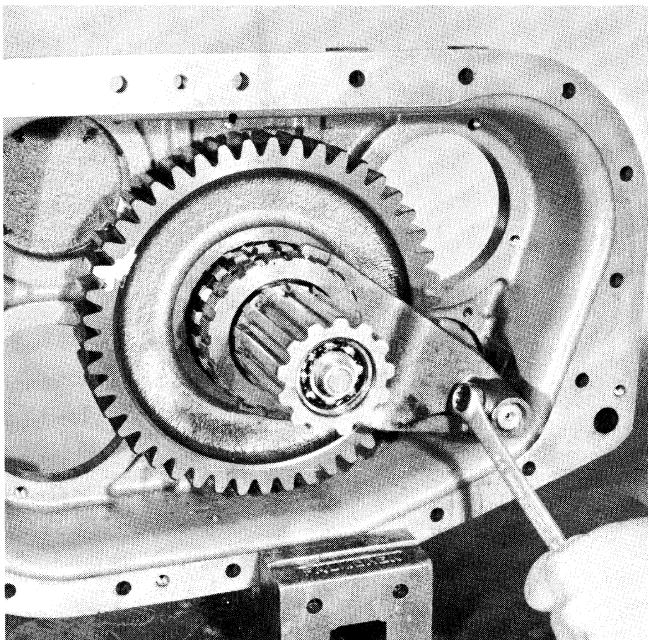
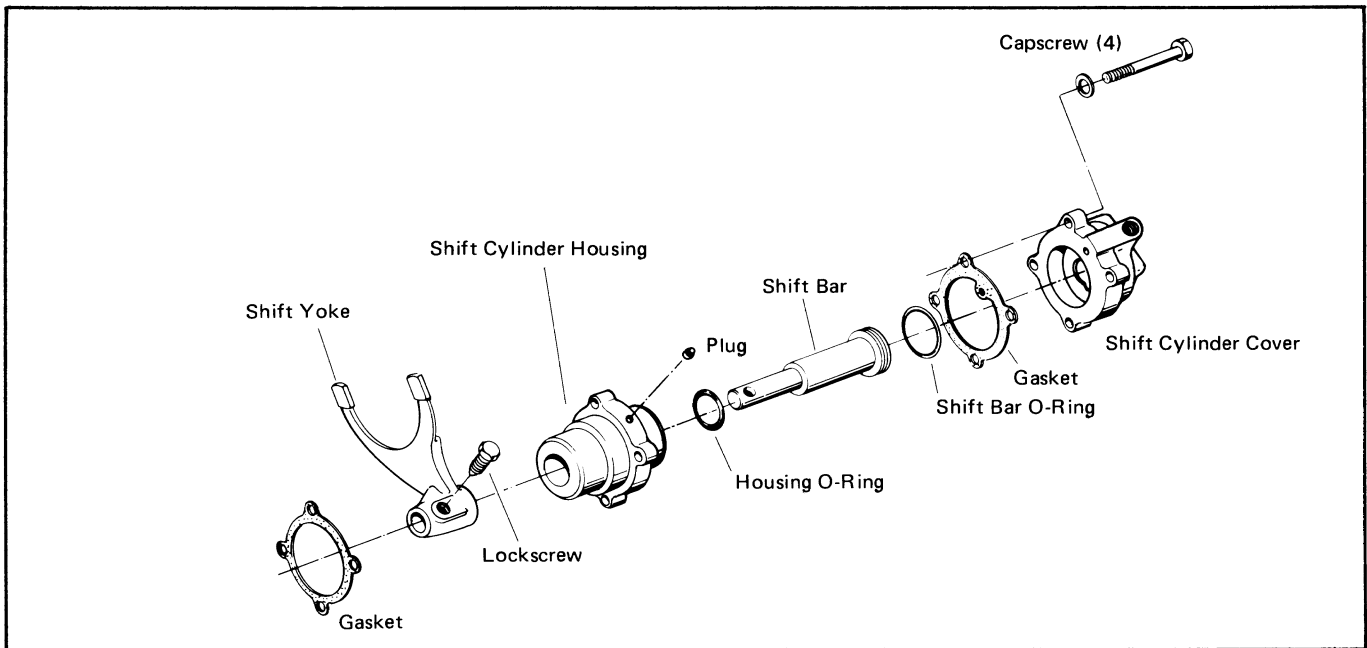

1. Cut the lockwire and turn out the lock screw on the low gear shift yoke.

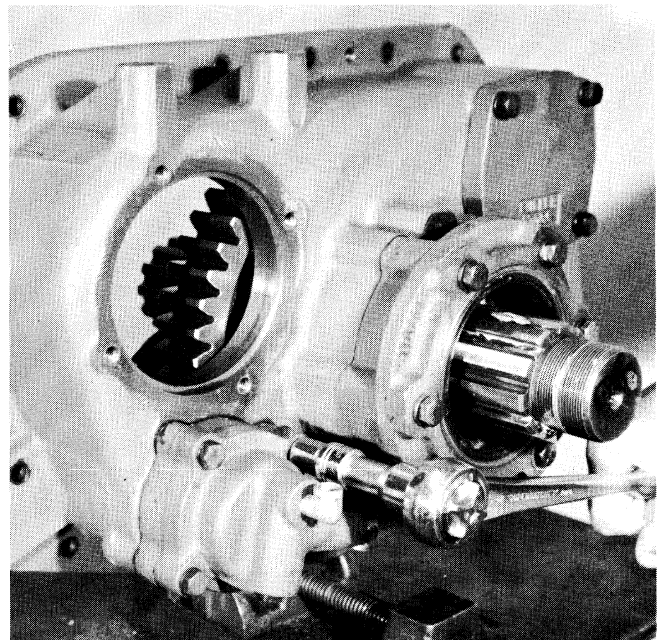

2. Turn out the capscrews and remove the cylinder cover.

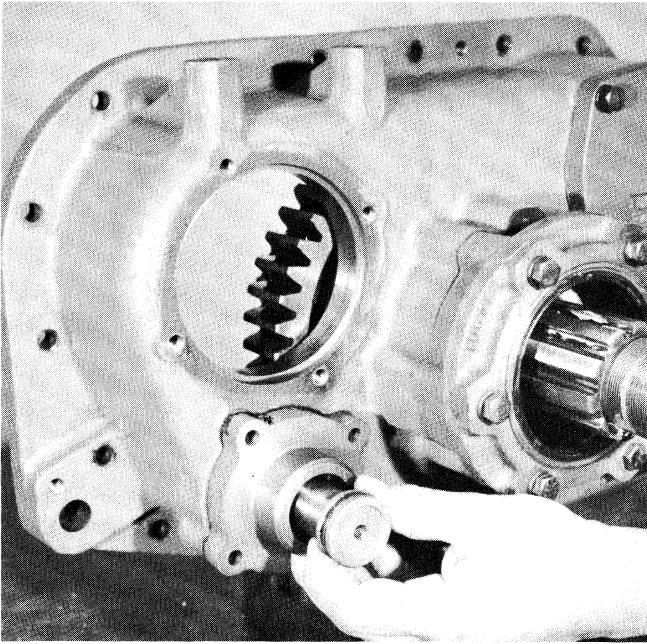

3. Pull the shift bar to the rear and from the cylinder housing. If necessary, remove the O-ring from the large diameter of the bar.

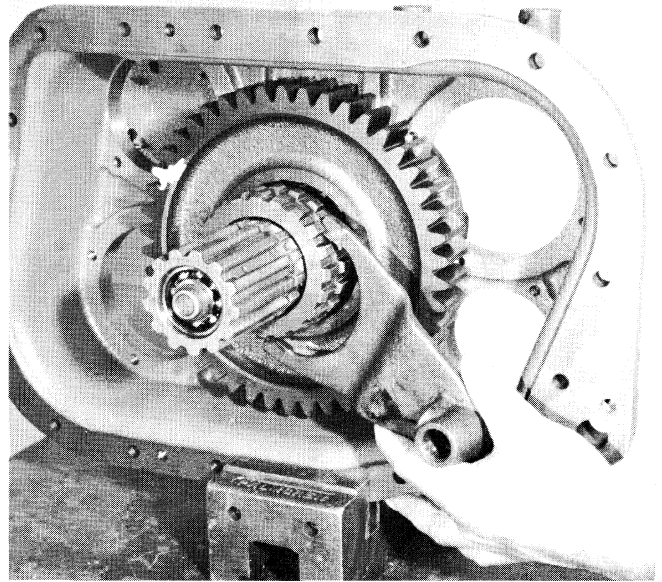

5. Remove the shift yoke from the sliding clutch.

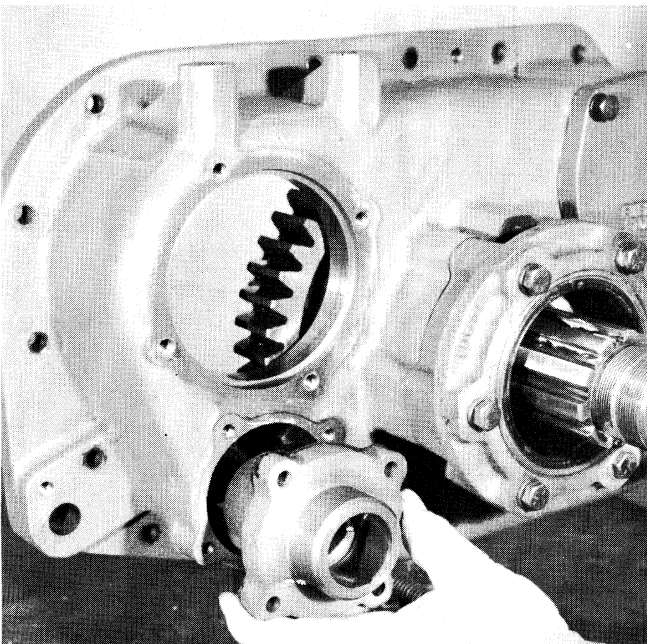

4. Remove the cylinder housing from the auxiliary housing. If necessary, remove the O-ring from the bore in the housing.

D. Removal of the Range Mainshaft

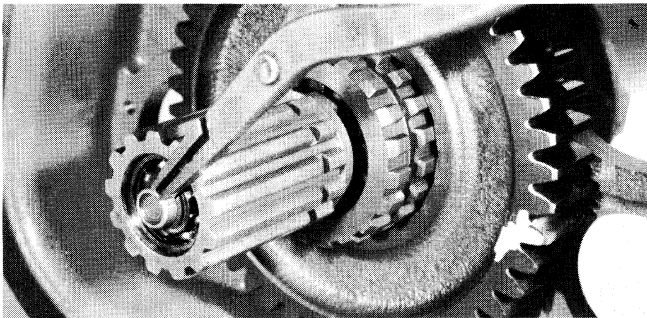
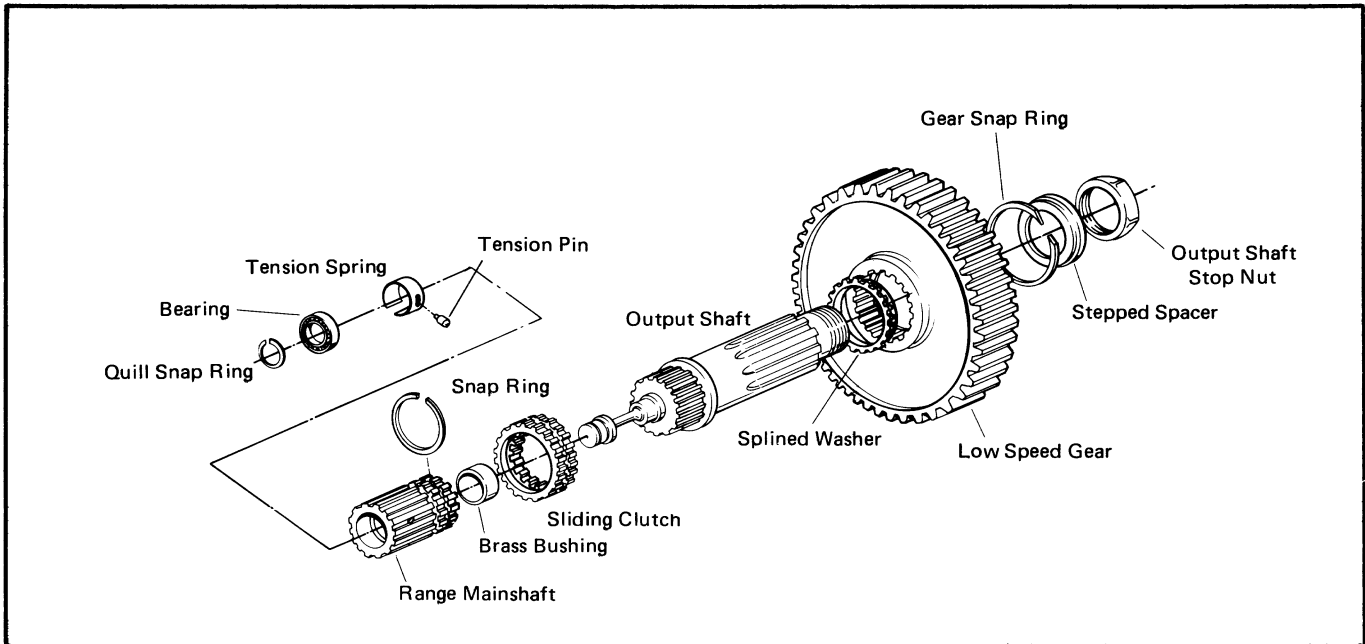

1. Remove the snap ring from the front of the output shaft quill.

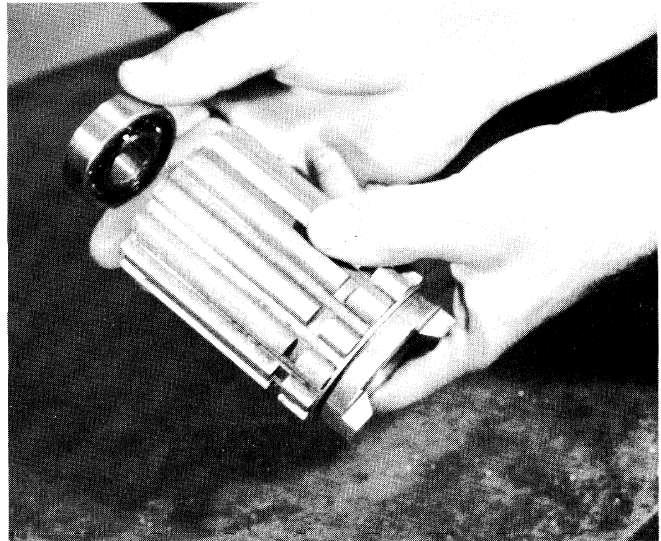

3. Remove the bearing from the bore of the mainshaft and, if necessary, remove the brass bushing, snap ring and tension spring from the mainshaft.

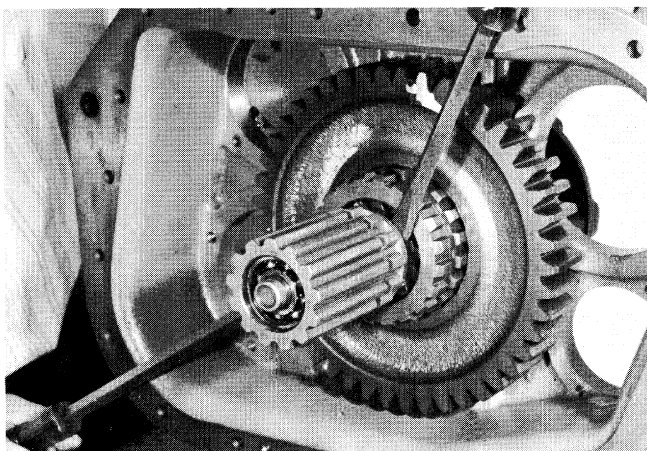

2. Use pry bars or equivalent to move the mainshaft forward and off the quill.

E. Removal of the Low Speed Gear, Output Shaft and Rear Bearing Assembly

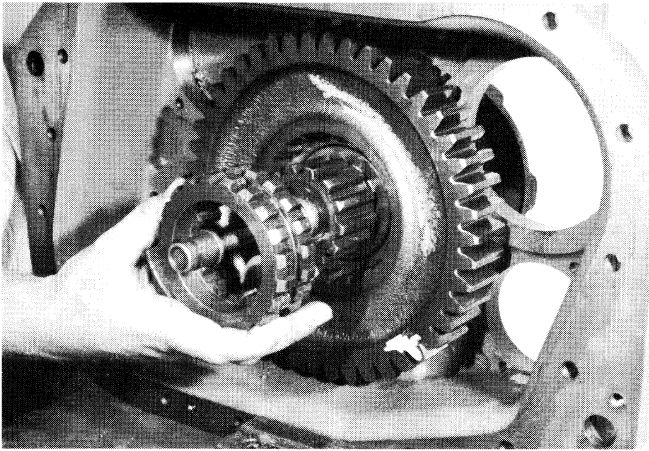

1. Remove the sliding clutch from the splines of the output shaft.

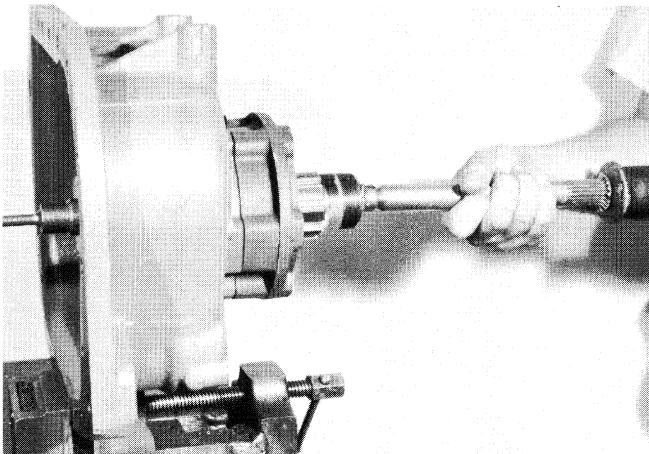

2. Use a soft bar and mallet to drive the output shaft forward and from the rear bearing assembly.

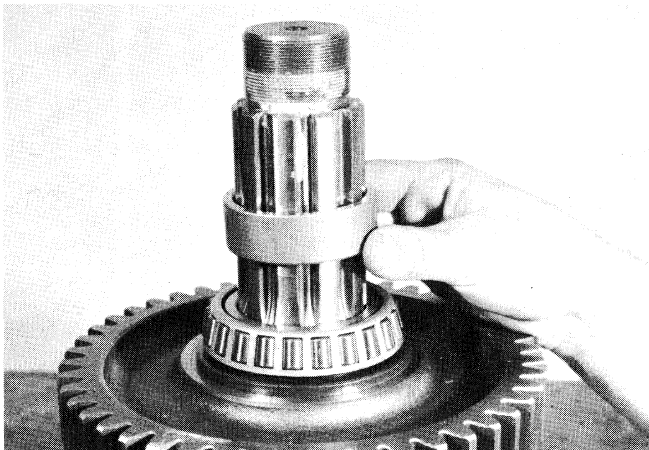

3. Remove the bearing inner spacer from the output shaft.

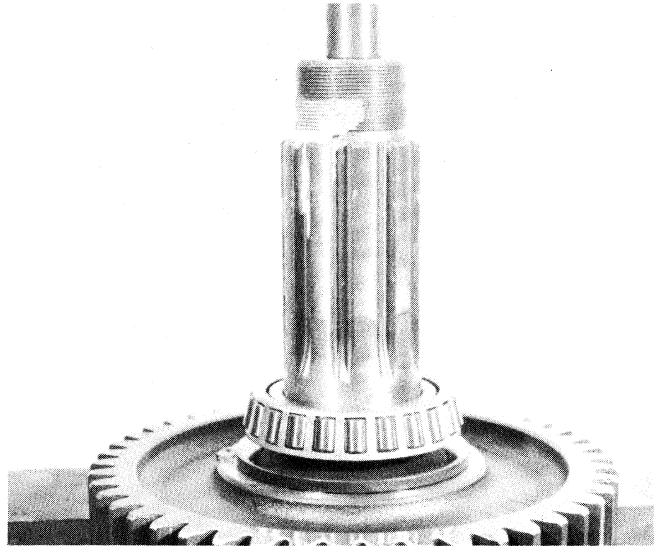

4. Using the low speed gear as a base, press the front bearing cone from the output shaft. This will free the bearing, gear, washer and spacer.

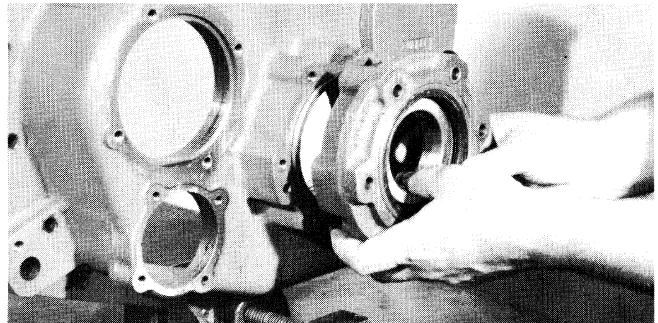

5. Turn out the retaining capscrews and remove the rear bearing housing from the auxiliary section. If necessary, remove the oil seal from the housing. Remove the rear bearing cone from the rear housing.

**NOTE:** Removal procedures will most likely damage the oil seal and should not be attempted unless replacement of the seal is planned.

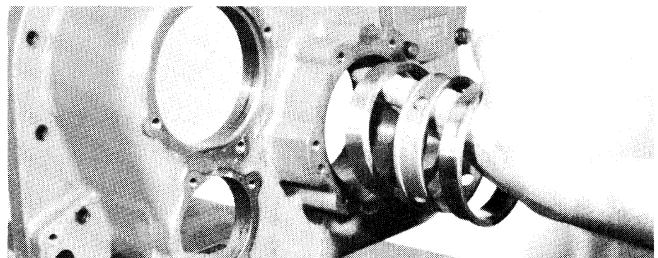

6. Use a soft bar to tap the two bearing cups and outer spacer from the auxiliary housing bore.



## Inspection

Before reassembling the transmission, the individual parts should be carefully checked to eliminate those damaged from previous service. This inspection procedure should be carefully followed to insure the maximum of wear life from the rebuilt unit.

The cost of a new part is generally a small fraction of the total cost of downtime and labor, should the use of a questionable part make additional repairs necessary before the next regularly scheduled overhaul.

Recommended inspection procedures are set forth in the following check list:

### A. Bearings

1. Wash all bearings in clean solvent. Check balls, rolls and races for pits and spalled areas. Replace bearings which are pitted or spalled.

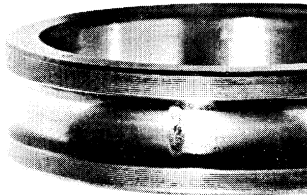

*Spalled Bearing –  
Extreme Load*

2. Lubricate bearings which are not spalled or pitted and check for axial and radial clearances. Replace bearings with excessive clearances.

3. Check fits of bearings in case bores. If outer races turn freely in the bores, the case should be replaced.

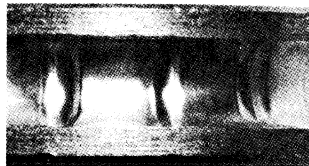

*False Brinnelling –  
Vibration Without  
Rotation*

### B. Gears

1. Check operating gear teeth for pitting on the tooth faces. Gears with pitted teeth should be replaced.
2. Check all engaging gear teeth. Gears with teeth worn, tapered or reduced in length from clashing in shifting should be replaced.
3. Check axial clearances of gears. Where excessive clearance is found, check gear snap ring, washer, spacer and gear hub for excessive wear.

### C. Splines

1. Check splines on all shafts for wear. If sliding clutch gears, companion flange or clutch hub have worn into the sides of the splines, the shafts in this condition should be replaced.

### D. Thrust Washers

1. Check surfaces of all thrust washers. Washers scored or reduced in thickness should be replaced.

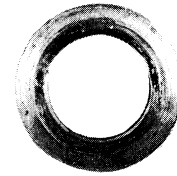

### E. Reverse Gear and Shaft

1. Check bearing sleeve for wear from action of roller bearings.

### F. Gray Iron Parts

1. Check all gray iron parts for cracks and breaks. Replace or repair parts found to be damaged. Heavy castings may be welded or brazed providing the cracks do not extend into bearing bores or bolting surfaces.

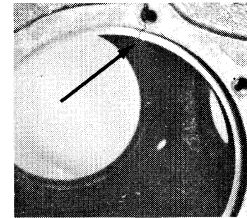

### G. Clutch Release Parts

1. Check clutch release parts. Replace yokes worn at cam surfaces and bearing carrier worn at contact pads.

2. Check pedal shafts. Replace those worn at bearing surfaces.

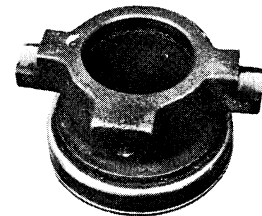

**H. Shifting Bar Housing Assembly**

1. Check yokes and blocks for wear at pads and lever slot. Replace worn parts.
2. Check yokes for alignment. Straighten those which are sprung.
3. Check yokes for excessive wear; replace worn yokes.
4. Check lockscrews in yokes and blocks. Tighten and rewire those found loose.
5. If housing has been dismantled, check neutral notches of shifting bars for wear from interlock balls. Bars indented at points adjacent to the neutral notch should be replaced.

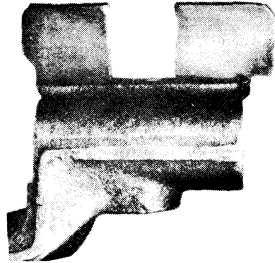

**I. Gear Shift Lever Housing Assembly**

1. Check spring tension on shift lever. Replace tension spring and washer if lever moves too freely.
2. If housing is dismantled, check pivot pin and corresponding slot in lever for wear. Replace both parts if worn.

**J. Bearing Covers**

1. Check covers for wear from thrust of adjacent bearing. Replace covers worn and grooved from thrust of bearing outer race.
2. Check bores of covers for wear. Replace those worn oversize.

**K. Oil Return Threads and Seals**

1. Check oil return threads in front bearing cover. If sealing action of threads has been destroyed by contact with input shaft, replace the cover.
2. Check oil seal in mainshaft rear bearing cover. If sealing action of lip has been destroyed, replace seal.

**L. Sliding Clutches**

1. Check all yokes and yoke slots in sliding clutches for extreme wear or discoloration from heat.
2. Check engaging teeth of sliding clutches for partial engagement pattern.

**M. Front Bearing Cover**

1. Check inside hub of front bearing cover for wear caused by backing off of drive gear bearing nut.

**Location of Gaskets**

Seat gasket with shellac on part to be installed. Use new gaskets throughout when reassembling transmission. Gaskets are located between the following parts:

**T-955AL, GL**

1. Gear Shift lever housing and shift bar housing.
2. Shift bar housing and case.
3. Reverse light plug.
4. Tension spring cover plate.
5. Clutch housing and case.
6. Front bearing cover and case.
7. Rear plate and case.

8. Mainshaft rear bearing cover and rear plate.
9. Rear plate cover and rear plate.
10. Right aux. countershaft rear bearing cover and rear plate.
11. Left aux. countershaft rear bearing cover and rear plate.
12. Large PTO cover and case.
13. Small PTO cover and case.

**T-955ALL**

- To the above list add:
1. Low gear shift cylinder cover and cylinder.
  2. Low gear shift cylinder and case.

## Torque Ratings

Recommended torque ratings, location and thread sizes of capscrews and nuts are listed below. Capscrew lengths are given for reference purposes as a guide for installation at proper locations.

Correct torque application is extremely important to assure long transmission life and dependable performance. Over-tightening or under-tightening can result in a loose installation and, in many instances, eventually cause damage to transmission gears, shafts or bearings. Do not torque capscrews dry.

<b>CAPSCREWS</b>			
Location	Qty.	Thread Size And Length	Torque Rating Foot-Pounds
Filter Bracket	2	3/8-16 x 3/4	20-25
*PTO Cover, small	6	3/8-16 x 3/4	18-23 (12-15 with oil filter)
Low Gear Shift Cylinder (T-955ALL only)	4	5/16-18 x 1-7/8	20-25
Aux. Drive Gear Retainer Ring	6	3/8-16 x 1	35-45
Shift Bar Housing	16	3/8-16 x 1-1/4	
Gear Shift Lever Housing	4	3/8-16 x 1-1/4	
Front Bearing Cover	6	3/8-16 x 1-1/4	
Countershaft Rear Bearing Covers	8	3/8-16 x 1-1/4	
Rear Plate to Case (T-955AL, GL only)	18	3/8-16 x 2	
	1	3/8-16 x 1-3/4	
Rear Plate to Case (T-955ALL only)	18	3/8-16 x 1-1/2	
	1	3/8-16 x 2	
Mainshaft Rear Bearing Cover	6	3/8-16 x 2-3/4	
PTO Cover, large	8	7/16-14 x 1-1/4	50-65
Clutch Housing to Case	2	1/2-13 x 1-1/2	70-75
	2	1/2-13 x 3-1/2	70-75
C/S Front Bearing Retainers	4	1/2-20 x 1	50-65

**\*NOTE:** Installing the capscrews with more than 23 ft-lbs. of torque will force the corners of the PTO cover away from the case with resultant oil leakage.

<b>NUTS</b>			
Location	Qty.	Thread Size	Torque Rating Foot-Pounds
Reverse Idler Shafts	2	5/8-18	75-80
Clutch Housing to Case	6	5/8-18	170-185
Drive Gear	1	2-1/8-16	250-300
Companion Flange or Yoke	1	2-16	450-500

## General Precautions for Reassembly

**IMPORTANT: Read this section before starting the detailed reassembly procedures.**

Make sure that interiors of case and housings are clean. It is important that dirt be kept out of transmission during reassembly. Dirt is abrasive and can damage polished surfaces of bearings and washers. Use certain precautions, as listed below, during reassembly.

1. **GASKETS** – Use new gaskets throughout the transmission as it is being rebuilt. Make sure all gaskets are installed, as omission of gasket can result in oil leakage or misalignment of bearing covers. See “Location of Gaskets” heading.
2. **O-RINGS** – Lubricate all O-rings with “Dow Corning 200 Fluid,” 50,000 cs.
2. **CAPSCREWS** – To prevent oil leakage, use shellac on all capscrews. See torque rating chart for recommended torque.
4. **ASSEMBLY** – Refer to the disassembly illustrations as a guide to reassembly.
5. **INITIAL LUBRICATION** – Coat all thrust washers and splines of shafts with Lubriplate during installation to provide initial lubrication, preventing scoring and galling.
6. **AXIAL CLEARANCES** – Maintain original axial clearances of mainshaft forward speed gears of .005” to .012”. Mainshaft reverse gear clearance is .005” to .038”. Refer to axial clearance chart on page 95 during reassembly of the mainshaft assembly.
7. **BEARINGS** – Use of flanged-end bearing drivers is recommended for the installation of bearings. These drivers apply equal force to both races of bearing, preventing damage to balls and races and maintaining correct bearing alignment with shaft and bore. If tubular or sleeve type driver is used, apply force only to inner race.
8. **UNIVERSAL JOINT COMPANION FLANGE** – Pull the companion flange tightly into place with the mainshaft nut, using 450-500 foot-pounds of torque. Make sure the speedometer gear is not used, a replacement spacer of the same width must be used. Failure to pull the yoke or flange tightly into place will permit the shaft to move axially with resultant damage to rear bearing.

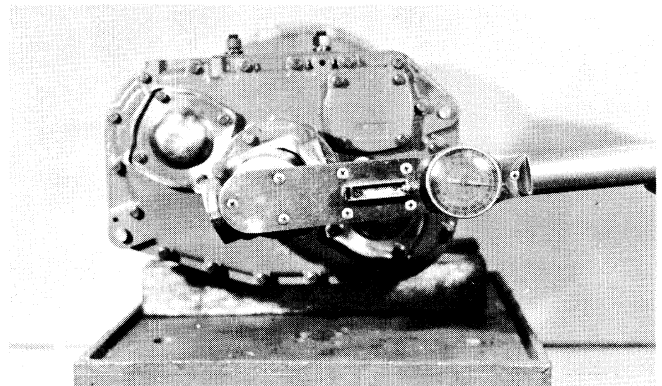
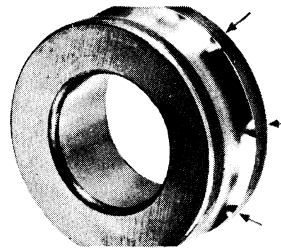

# REASSEMBLY INSTRUCTIONS

## I. Auxiliary Section

### T-955ALL, Models

#### A. Reassembly of the Low Speed Gear and Output Shaft

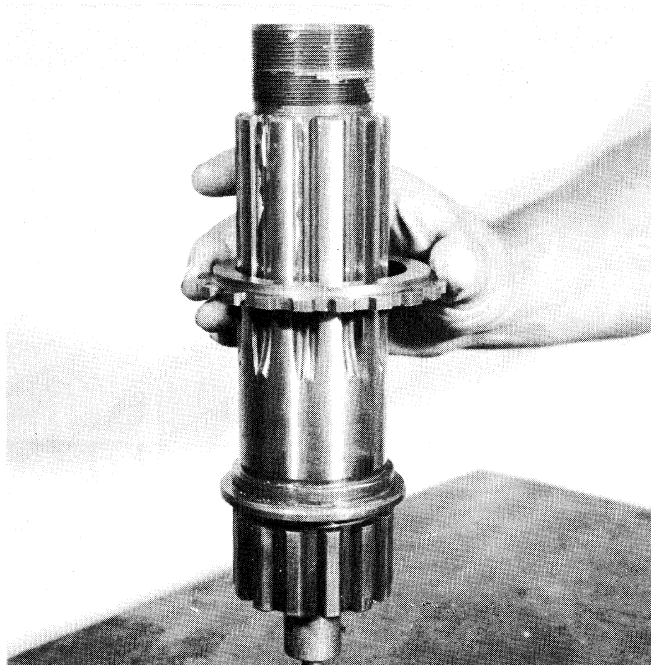

1. Place the output shaft, threaded end up, on blocking to prevent damage to the quill and install the splined washer on the shaft, stepped side up.

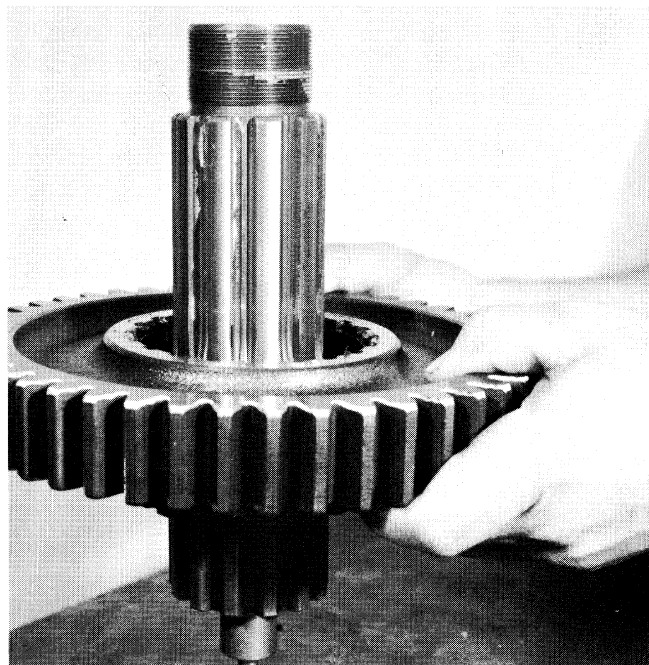

2. If previously removed, install the snap ring in the groove of the low speed gear and install the gear on the shaft, clutching teeth down.

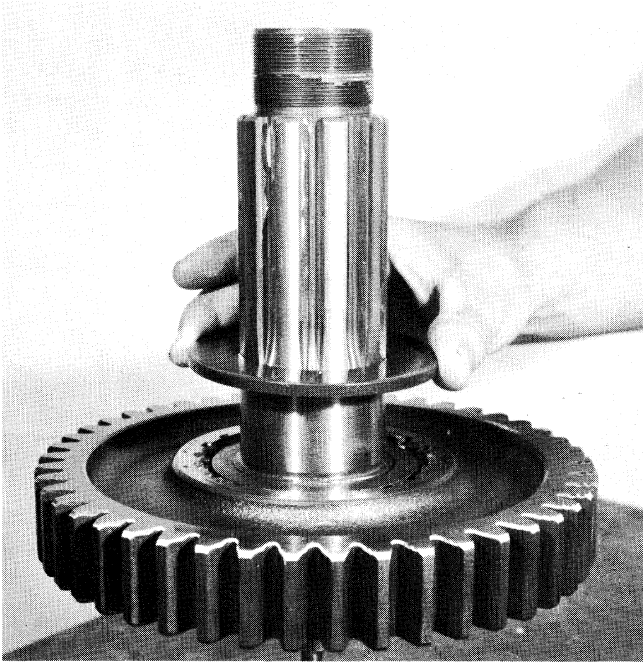

3. Install the rear washer on the shaft, flat side up.

**NOTE:** Heating of the bearing will facilitate installation.  
Do not heat the bearing over 275°F.

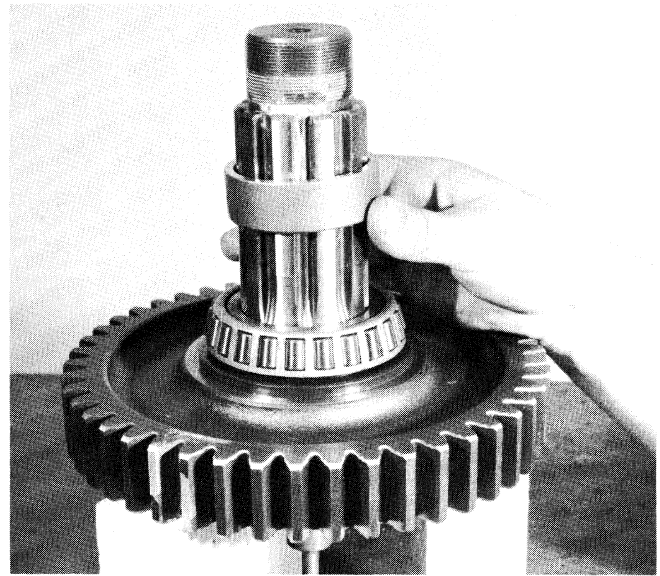

5. Install the spacer on the shaft.

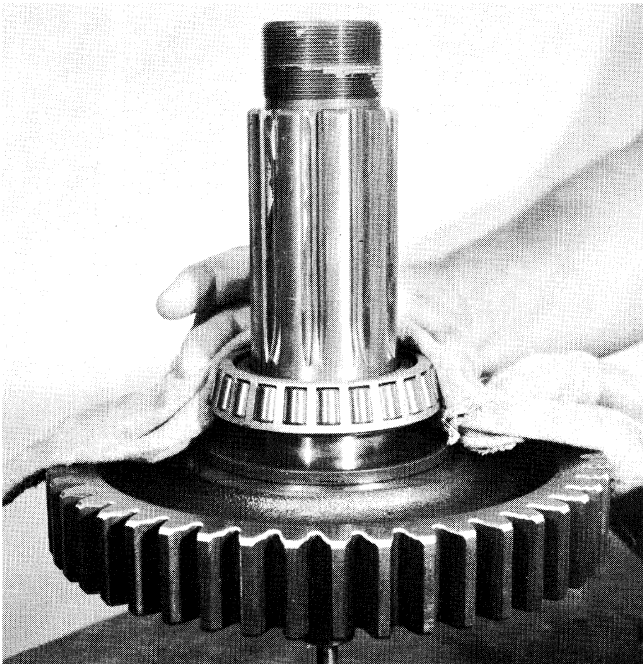

4. Install the front bearing cone on the shaft, taper facing up.

**B. Installation of the Rear Bearing Assembly**



1. Place the rear housing, machined face down, on a workbench and using a rubber mallet or equivalent, tap the front bearing cup into the rear housing bore. The tapered end of the cup should face down.



3. Place the rear bearing cup on the inner race and use a driver to tap all three evenly into position in the case bore. The lip of the rear cup will seat against the rear housing.

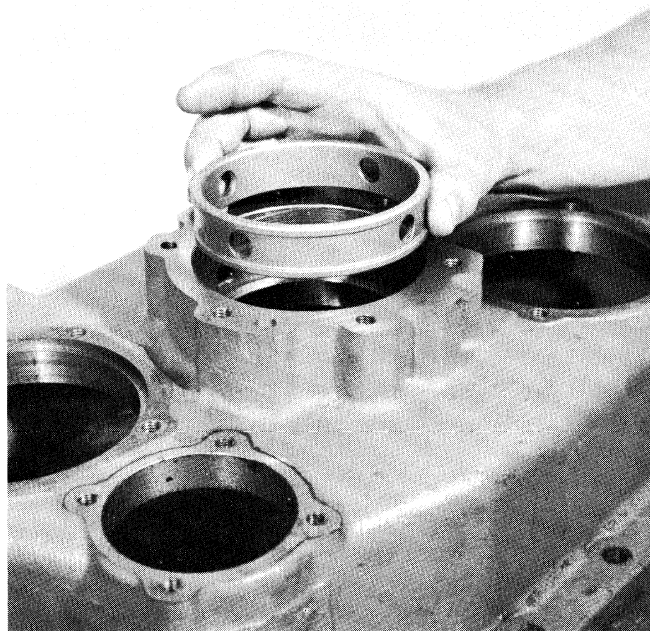

2. Place the bearing outer race on the front cup.

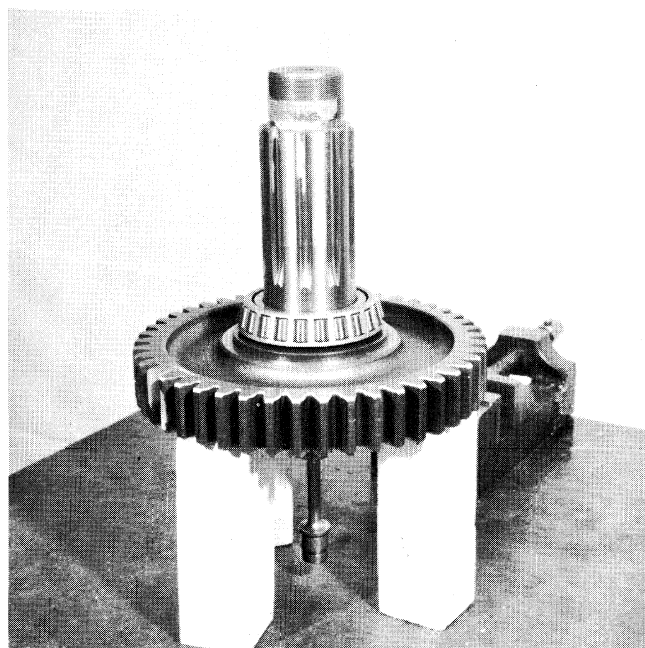

4. Place the output shaft on blocking supported by the low speed gear to prevent damage to the quill.

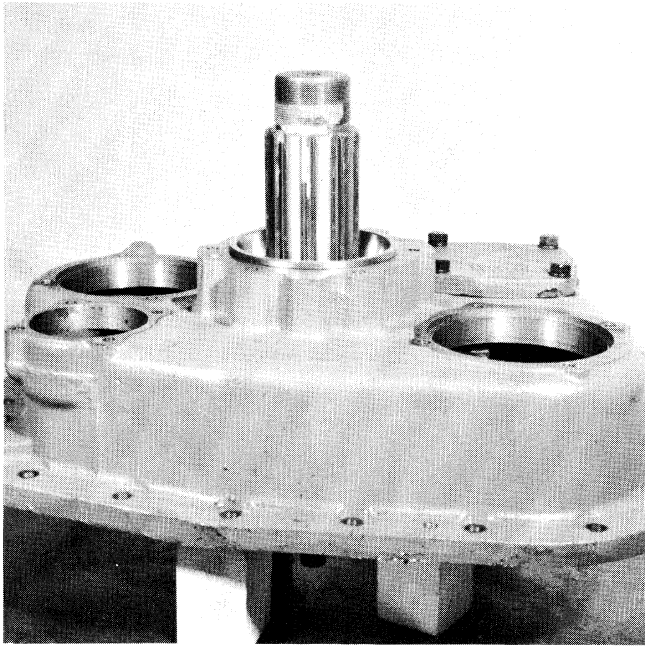

5. Place the rear housing over the output shaft.

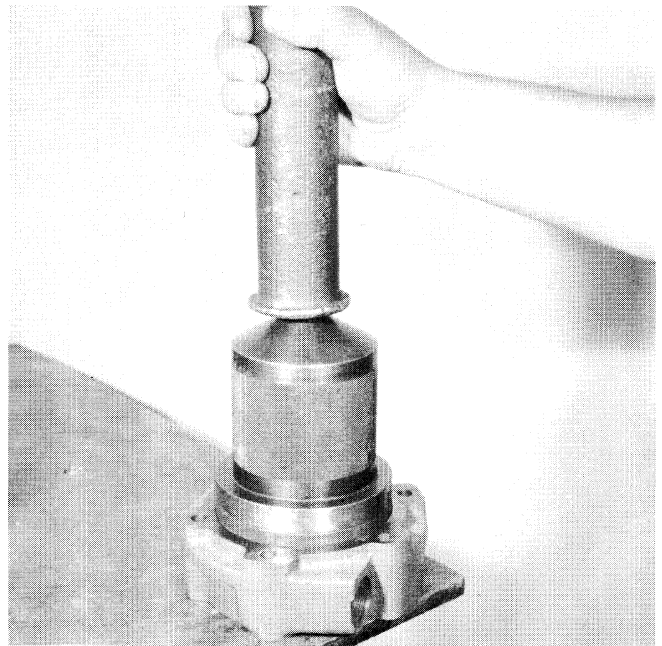

7. If previously removed, install the oil seal in the rear bearing housing, with the side with the seam to the inside of the housing.

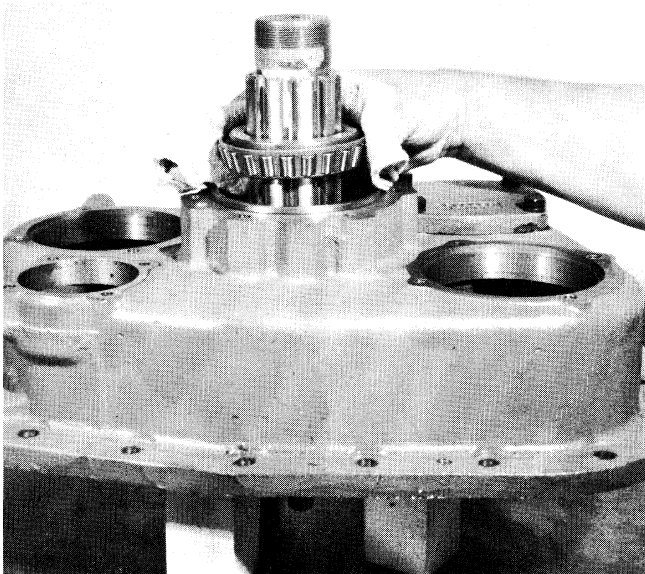

6. Install the rear bearing cone on the shaft and in the rear bearing cup.

NOTE: Heating of the bearing will facilitate installation. Do not heat the bearing over 275°F.

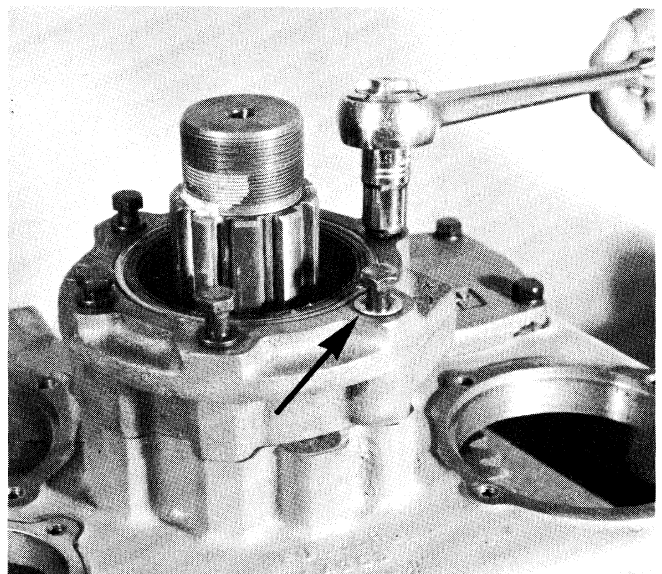

8. Install the rear bearing housing on the auxiliary housing. The cap screw with the brass bushing is installed in the hole which intersects the speedometer drive bore.



**C. Reassembly and Installation of the Low Gear Shift Cylinder Assembly**

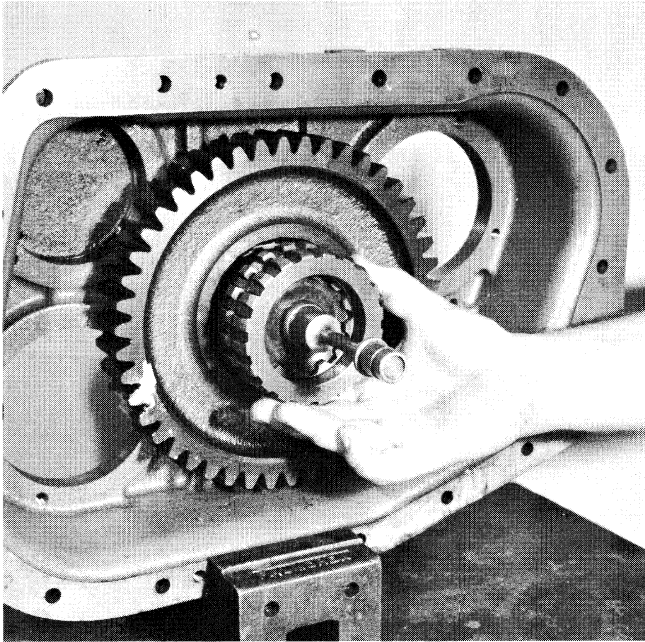

**1. Install the sliding clutch on the output shaft.**

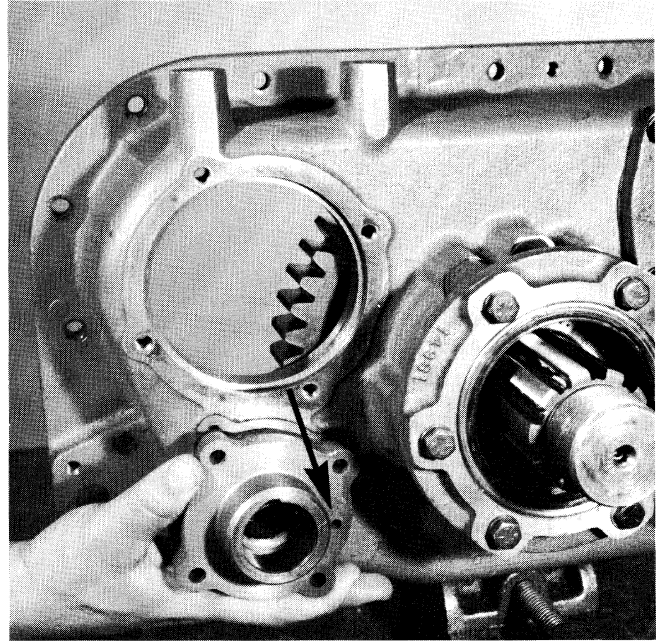

**3. Install the shift cylinder housing in the bore of the auxiliary housing with the small air channel to the right. If previously removed, install the O-ring in the bore of the cylinder housing.**

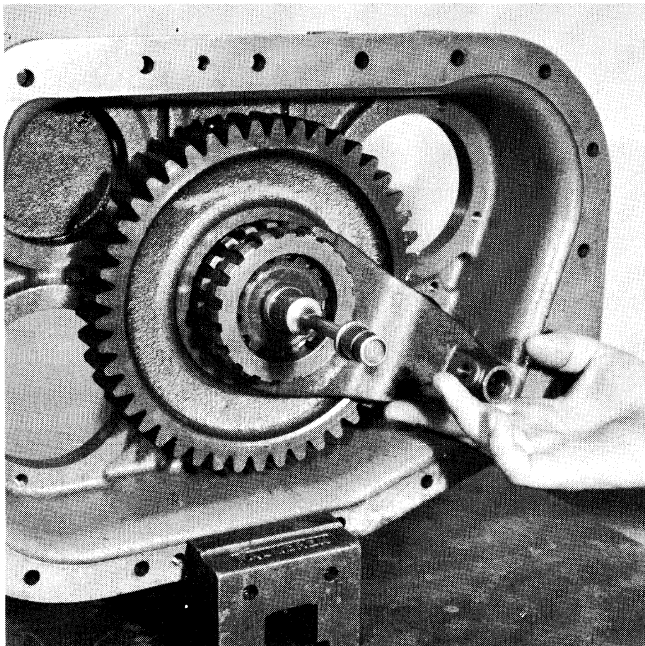

**2. Install the shift yoke in the sliding clutch groove with the hub to the front.**

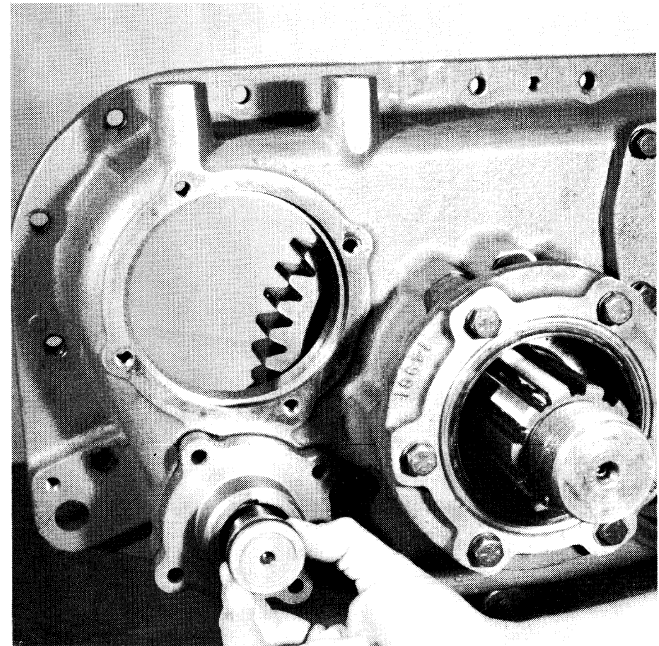

**4. If previously removed, install the O-ring in the large diameter of the shift bar and insert the bar into the cylinder housing, making sure that the front of the bar passes through shift yoke hub.**

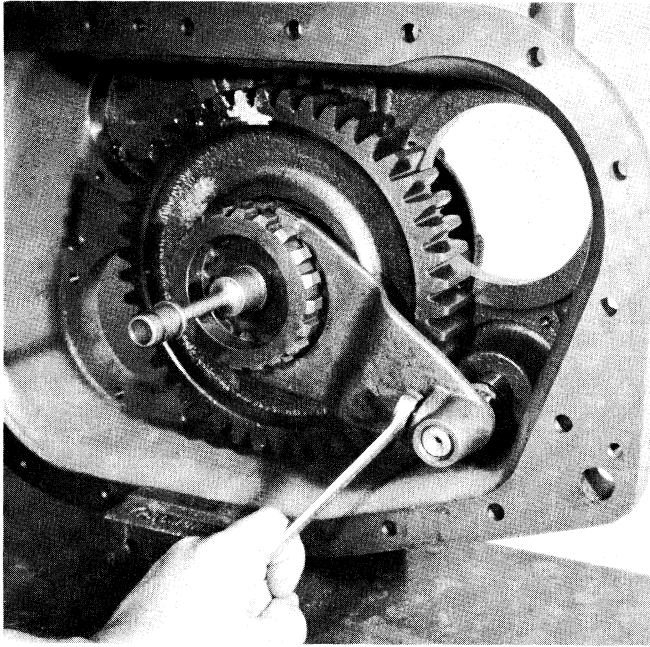

5. Align the hole in the shift bar with the cap screw bore in the shift yoke and install the yoke lock screw; tighten and wire securely.

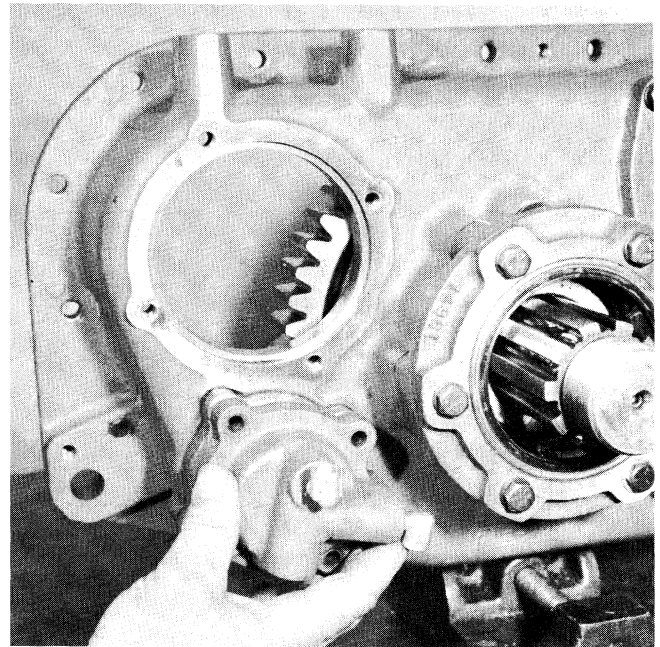

6. Install the shift cylinder cover on the housing, aligning the air channel with the channel in the cylinder housing. Secure with the four cap screws.

D. Installation of the Range Mainshaft and First Speed Gear

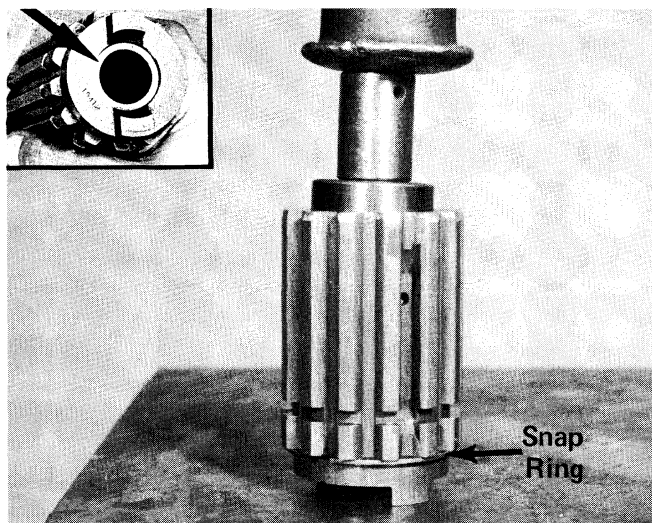

1. Install bearing in front of mainshaft. If previously removed: install snap ring on OD of mainshaft (rear groove); install tension spring inside shaft, aligning hole in spring with bore in shaft; install brass bushing in shaft bore (see insert).

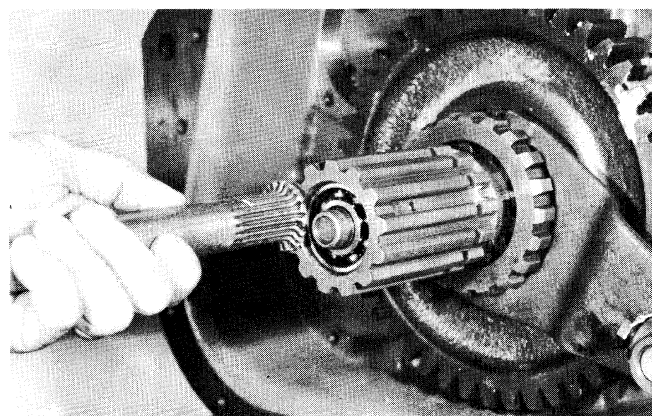

2. Tap the mainshaft evenly on to the output shaft quill with the bearing to the front.

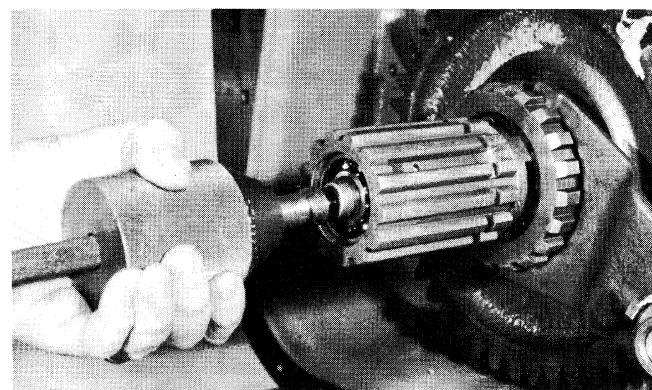

3. Install the snap ring on the front of the quill.

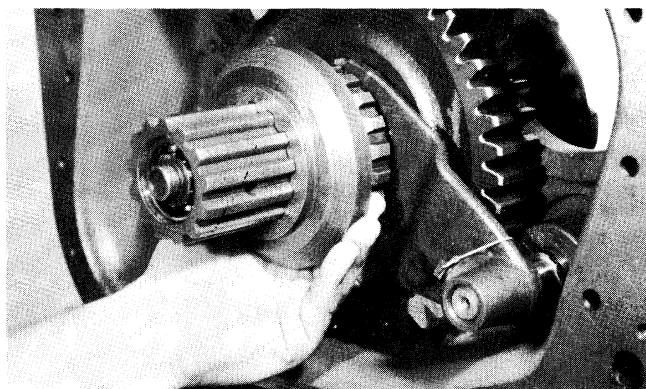

4. Install the coupler on the mainshaft, clutching teeth to the rear.

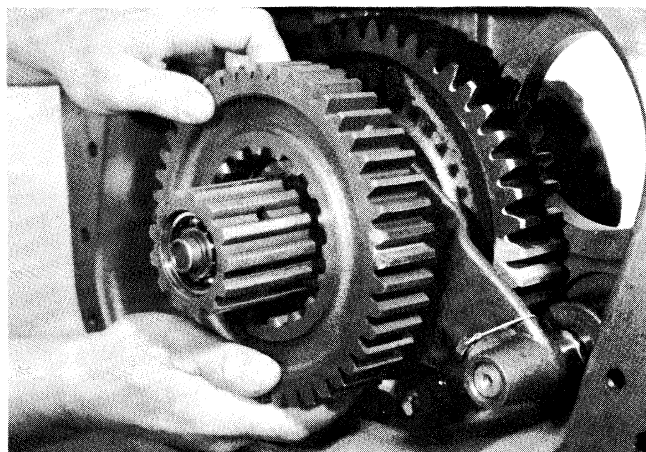

5. Install the first speed gear on the shaft, machined face to the rear.

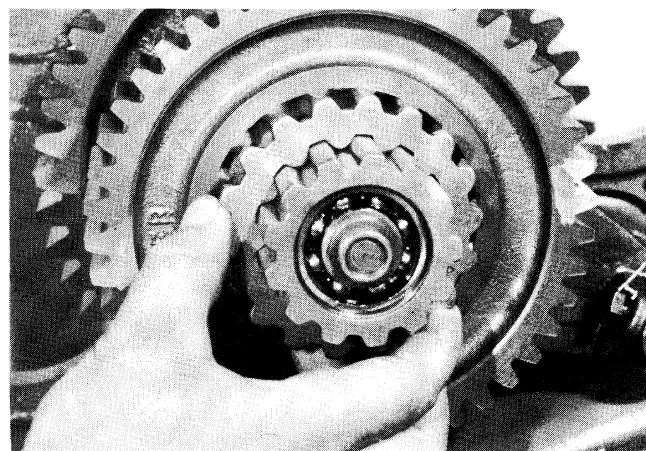

6. Install the splined washer on the shaft and in the hub of the gear.

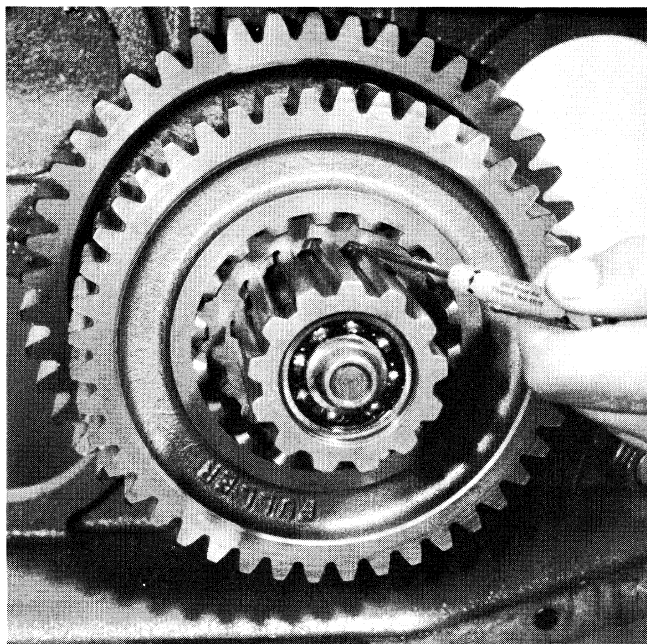

7. Turn the splined washer in the hub of the gear to lock the gear on the shaft.

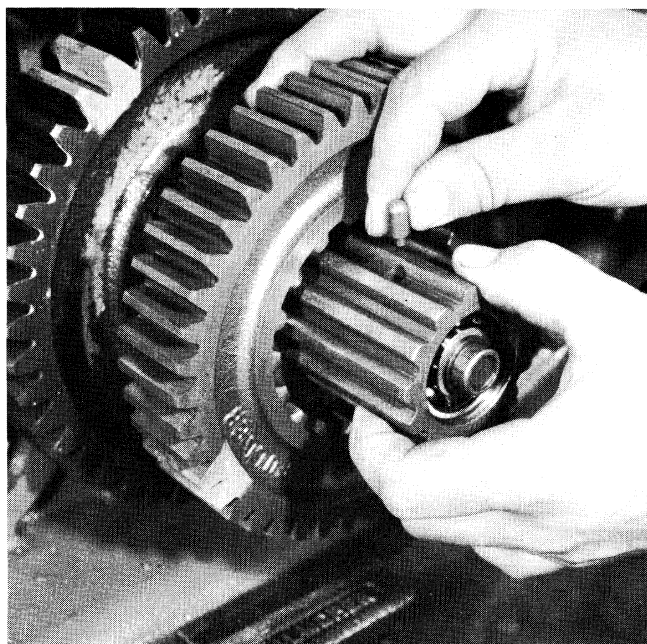

9. Hold the key in position, rotate the shaft and insert the clutch retainer in the bore in the shaft.

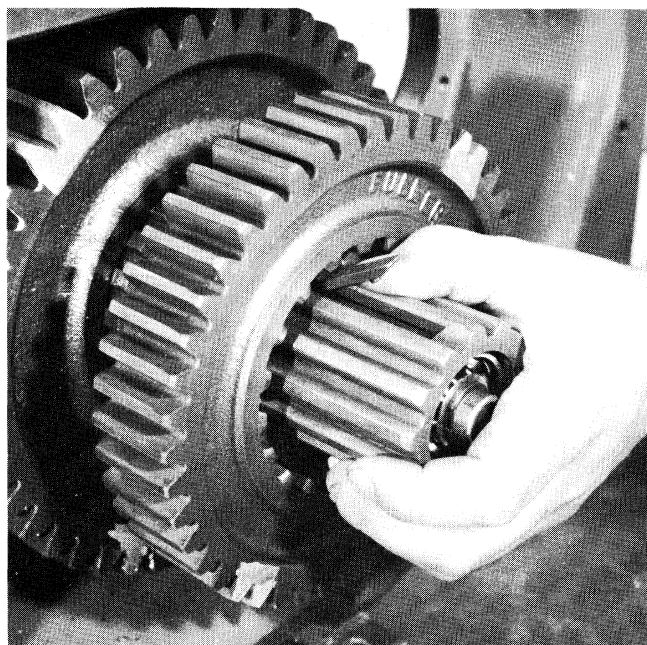

8. Install the key in the mainshaft keyway with the tab locked under the tooth on the gear.

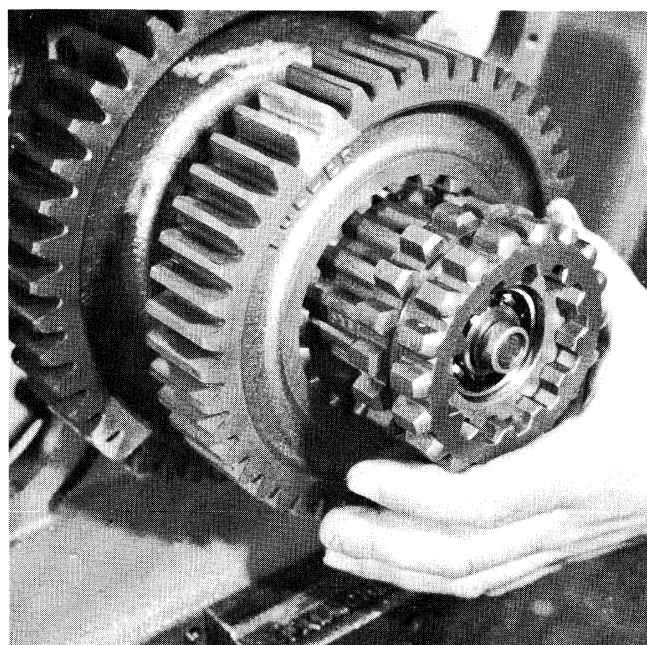

10. Install the sliding clutch on the shaft.

E. Timing and Installation of the Auxiliary Countershafts

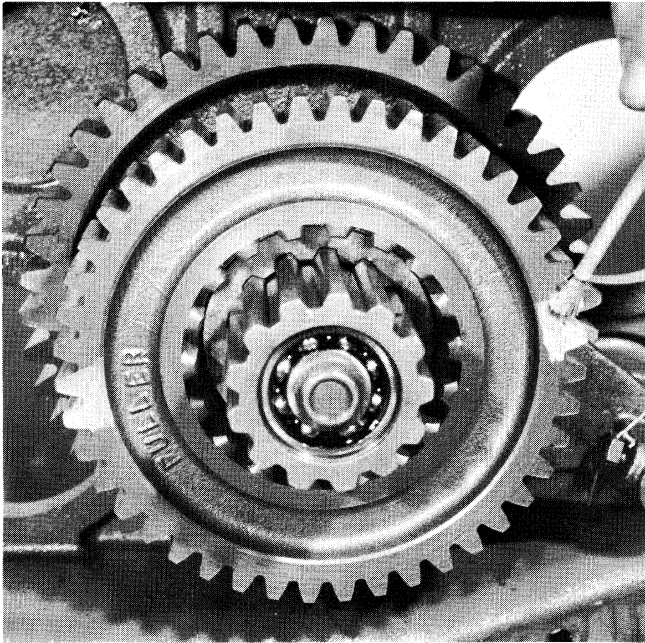

1. Mark any two teeth on the first speed gear and then mark the two teeth directly opposite.

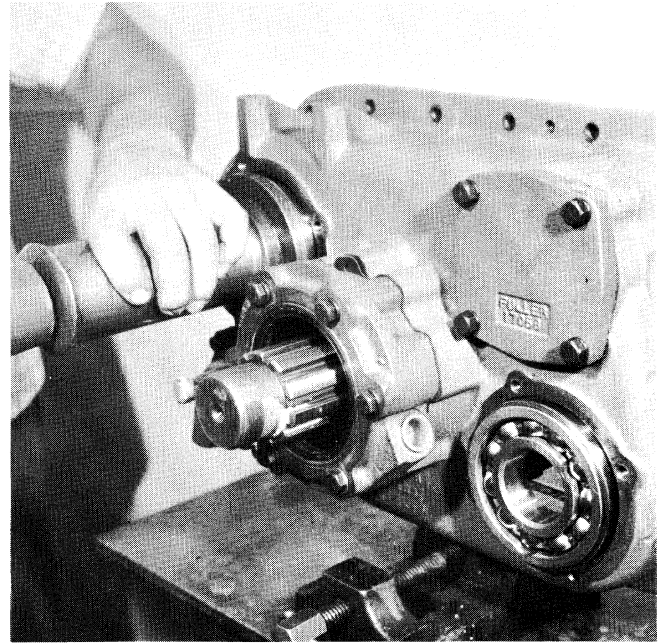

3. Use a bearing driver to install the auxiliary countershaft rear bearings in the rear case bores.

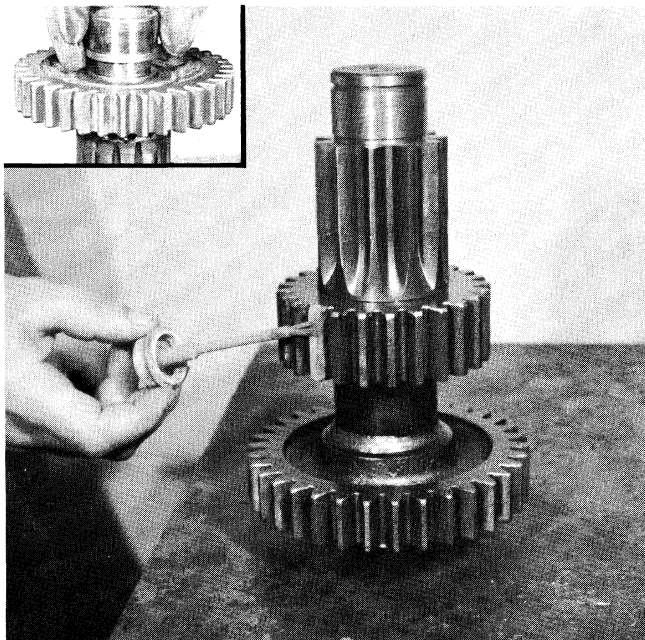

2. Mark the tooth on the first speed gear of each countershaft. This tooth is stamped with an "O". If previously removed, heat and install the bearing inner race on the front of each countershaft with the shoulder towards the gear (see insert).

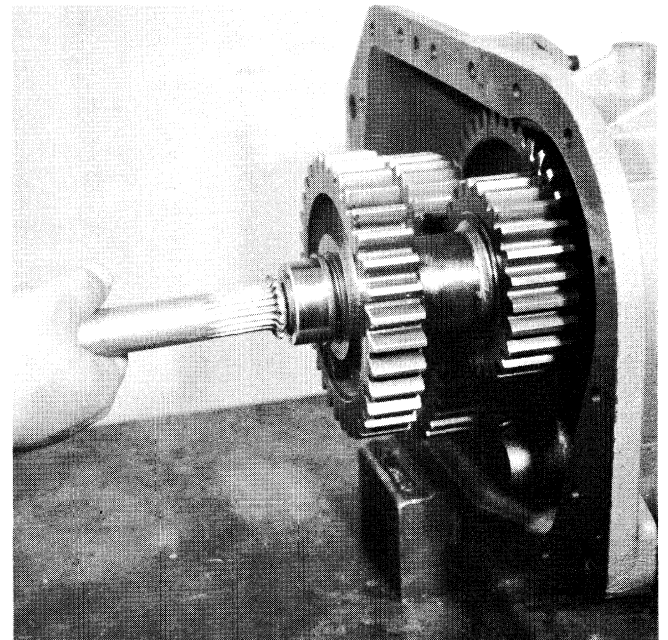

4. Align the marked tooth on each countershaft between the two sets of marked teeth on the first speed gear and use a soft bar and mallet to seat the countershafts in the rear bearings. Drive against the front of each shaft and the rear bearing alternately until the snap ring groove is exposed on the rear of each shaft.

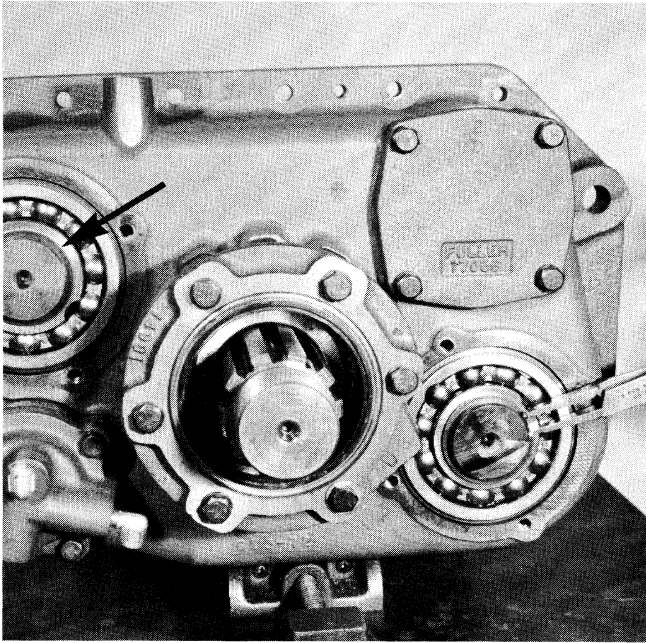

**5. Install the snap ring on the rear of each shaft.**

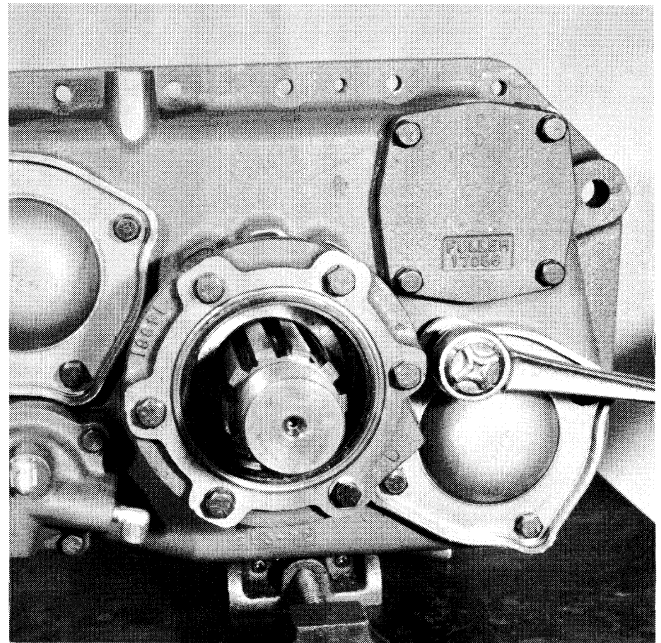

**6. Install the two rear bearing covers.**

## II. Auxiliary Section

### T-955AL, GL Models

#### A. Reassembly of the First Speed Gear and Output Shaft Assembly

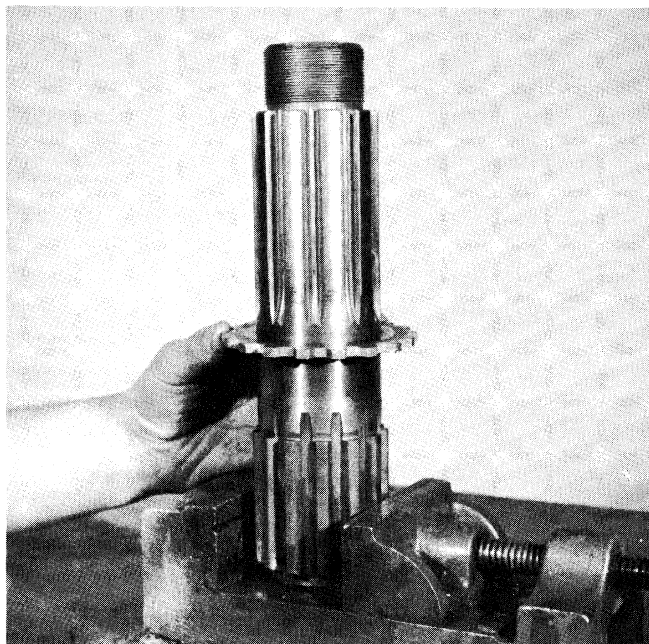

1. Place the output shaft on a workbench with the threaded end up and install the splined washer on the shaft.

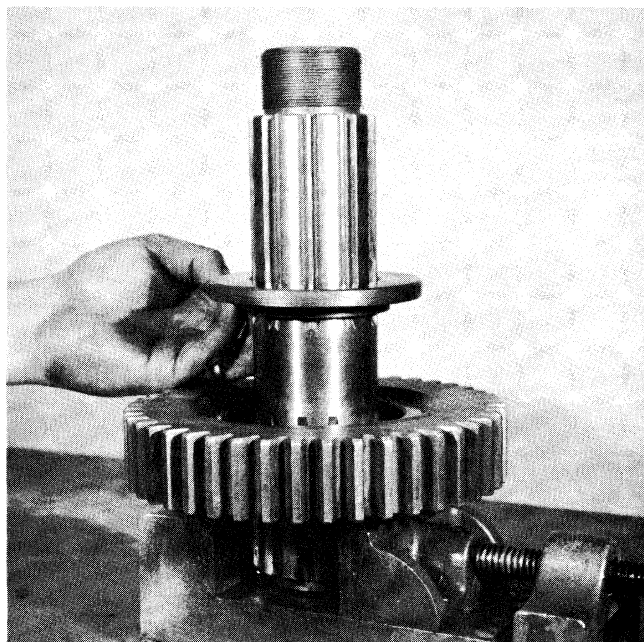

3. Place the stepped spacer on the shaft, flat side up.

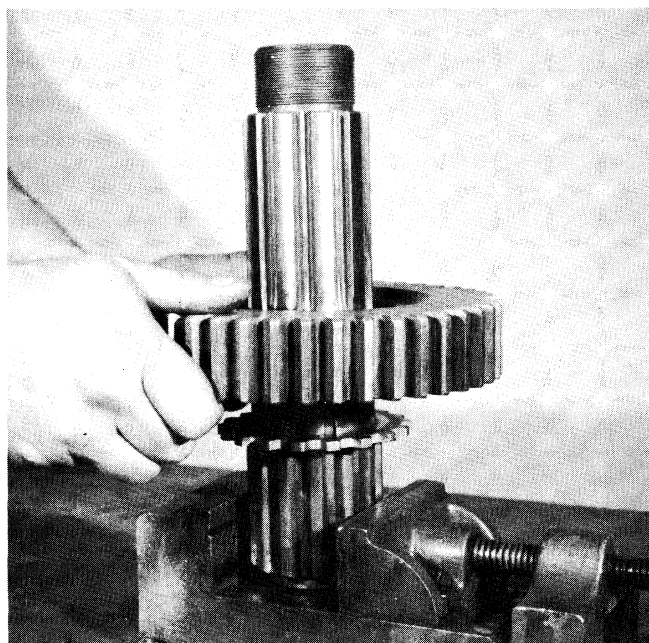

2. Place the first speed gear on the shaft, engaging the splines of the gear with the splines of the washer.

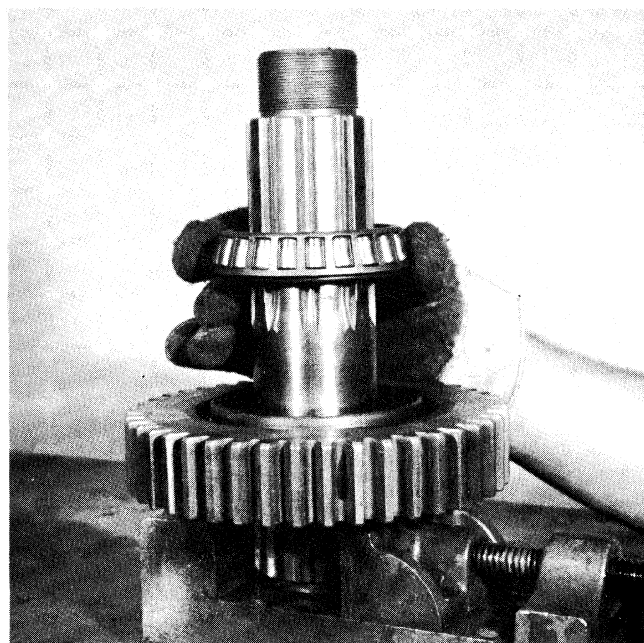

4. Install the front bearing cone on the shaft, taper up.

**NOTE:** Heating of the bearing will facilitate installation. Do not heat the bearing over 275°F.

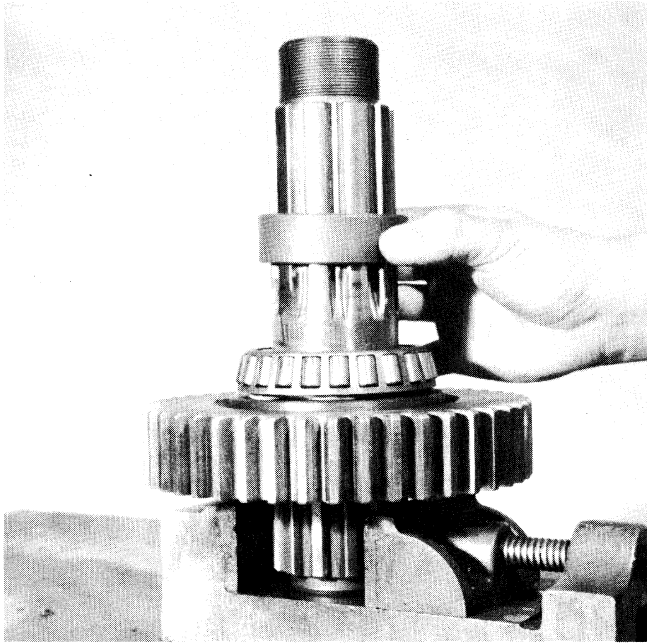

5. Install the bearing inner race on the output shaft.



**B. Installation of the Output Shaft and Rear Bearing Assembly**

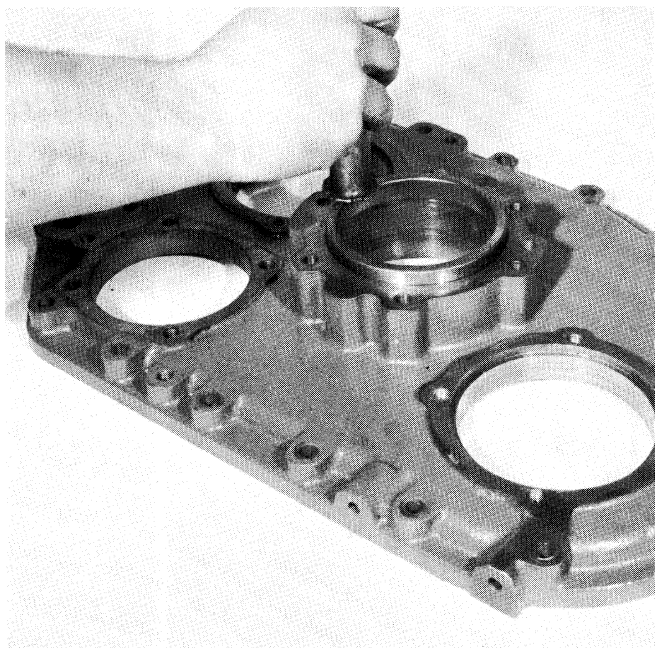

**1. Install the front bearing cup in the rear housing bore, wide diameter up, by tapping with a soft bar or rubber mallet.**

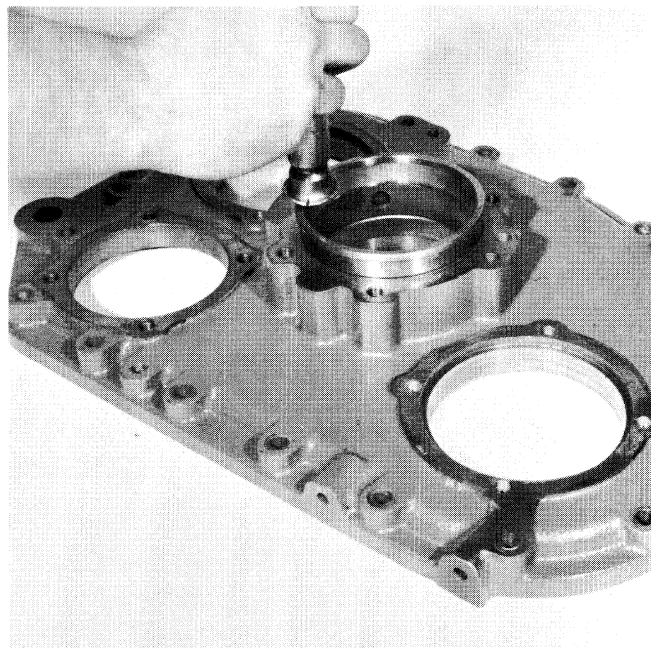

**3. Place the bearing rear cup on the outer race and tap all three evenly into the housing until the shoulder of the rear cup seats against the rear housing.**

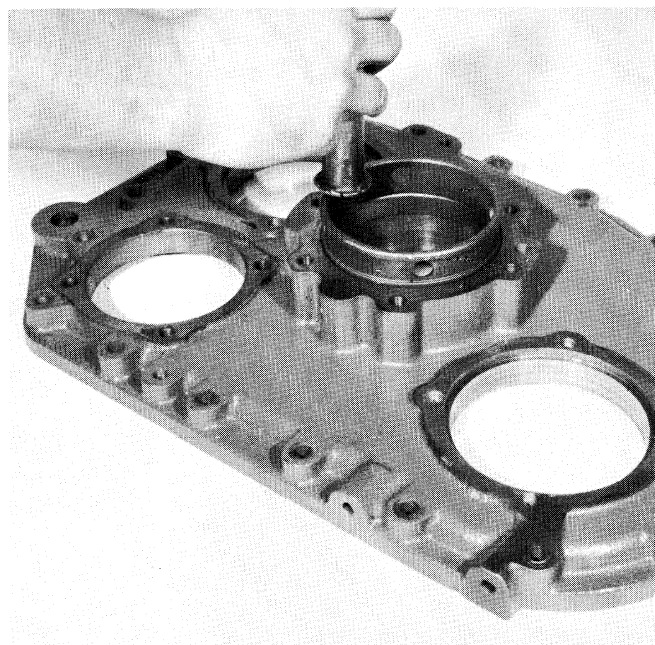

**2. Place the bearing outer race on the front cup and use a soft bar or rubber mallet to tap both into the housing.**

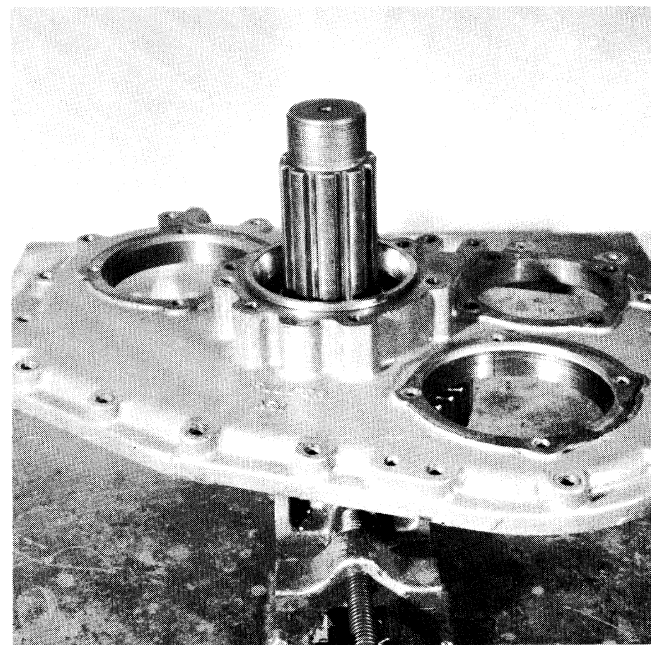

**4. Secure the output shaft, threaded end up, in a vise and place the rear housing over the shaft.**

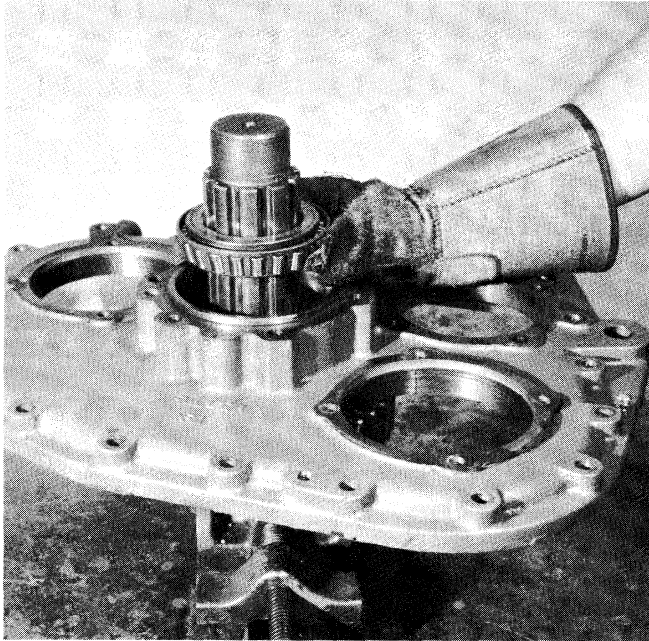

5. Install the rear bearing cone on the shaft and in the rear cup with the taper facing down.

**NOTE:** Heating of the bearing will facilitate installation. Do not heat the bearing over 275°F.

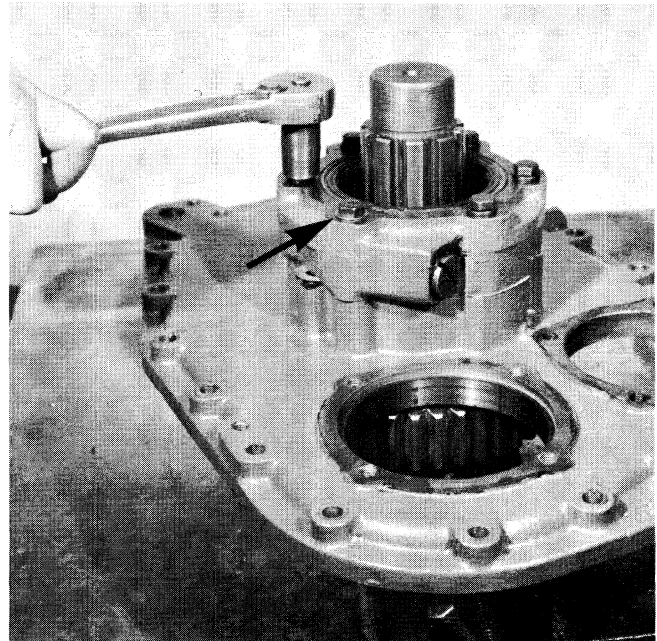

6. If previously removed, install the oil seal in the rear bearing housing and install the housing on the auxiliary section with the six retaining cap screws. The cap screw with the brass washer should be used in the hole which intersects the speedometer drive bore.

**C. Timing and Installation of the Auxiliary Countershaft Assemblies**

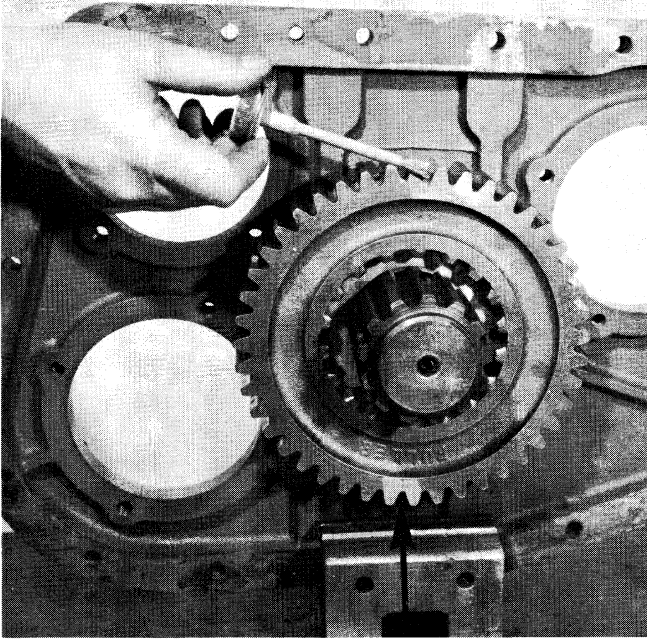

**1. Mark any two adjacent teeth on the first speed gear and then mark the two teeth directly opposite.**

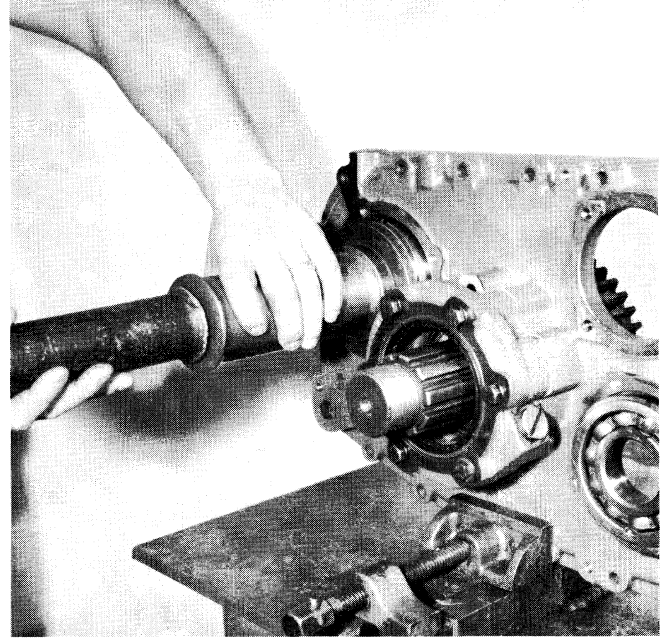

**3. Use a bearing driver to install the auxiliary countershaft rear bearings in the case bores.**

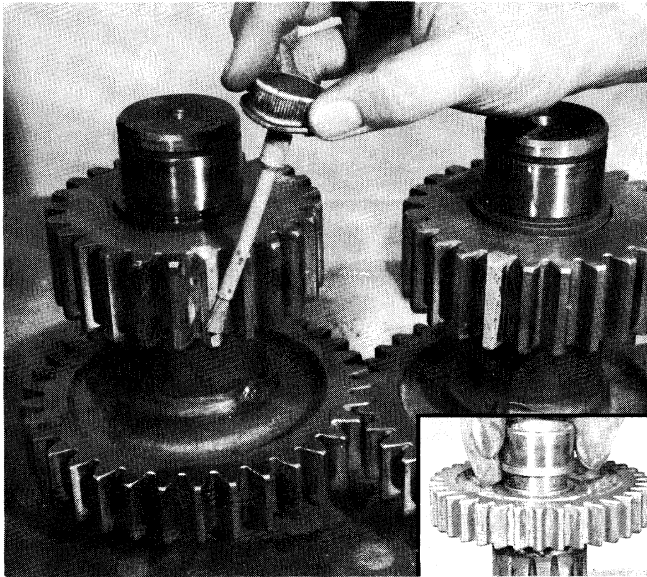

**2. Mark the tooth on the first speed gear on each auxiliary countershaft which is stamped with an "O". If previously removed, heat and install the bearing inner race on the front of each shaft, shoulder towards the gear (see insert).**

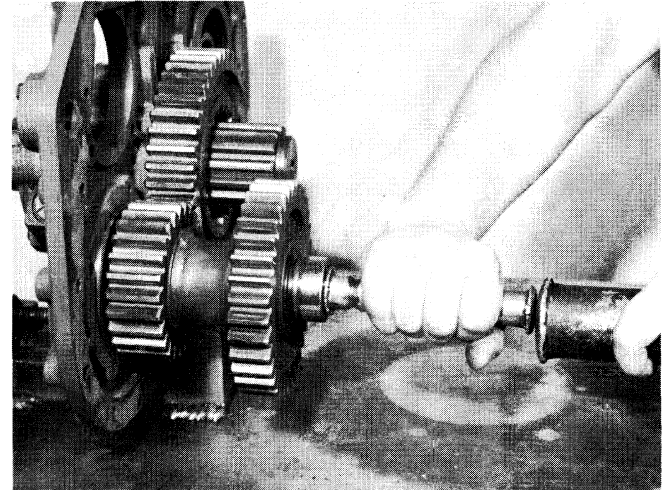

**4. Mesh the marked tooth on one of the countershafts between two of the marked teeth on the first speed gear and use a soft bar and mallet on the front of the shaft to start the shaft into the rear bearing. Continue driving against the bearing and the front of the shaft until the snap ring groove on the rear of the countershaft is exposed. Repeat procedure for the other countershaft.**

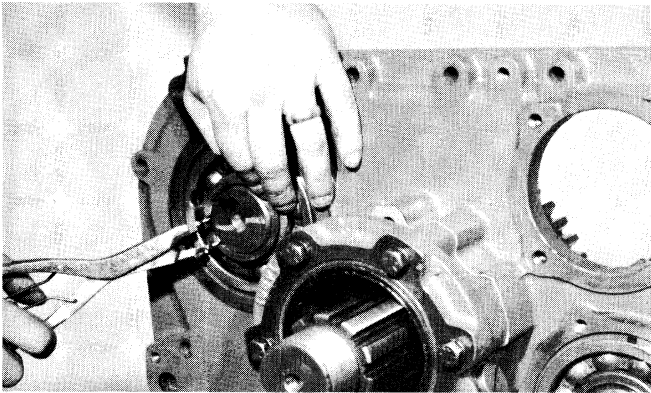

**5. Install the snap ring in the rear of each shaft.**

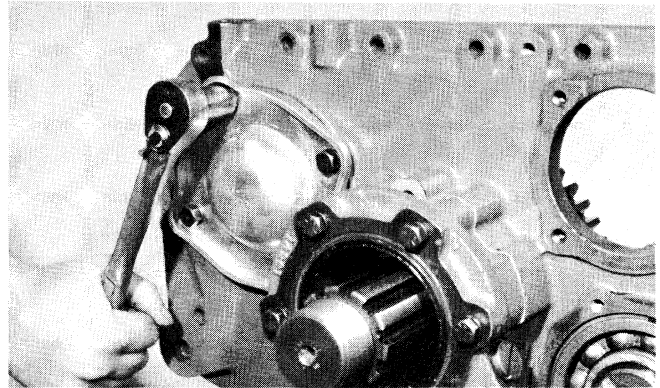

**6. Install the two rear bearing covers.**

#### **D. Installation of the First-Reverse Speed Sliding Clutch**

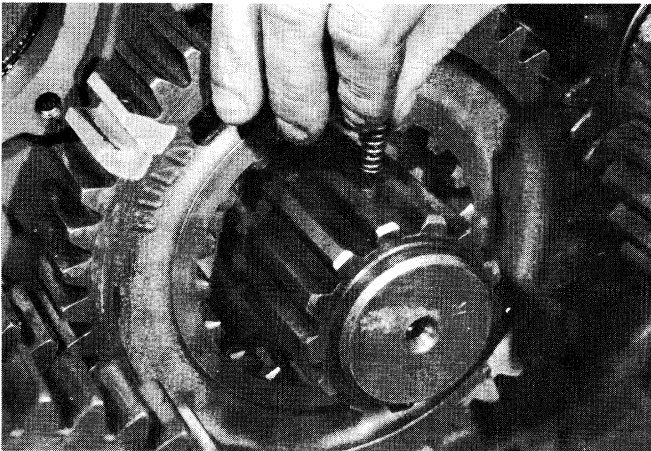

**1. Install the spring in the bore in the output shaft.**

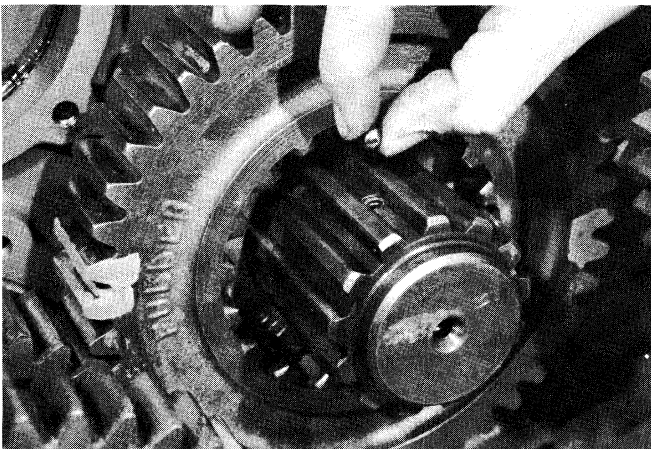

**2. Install the tension ball over the spring.**

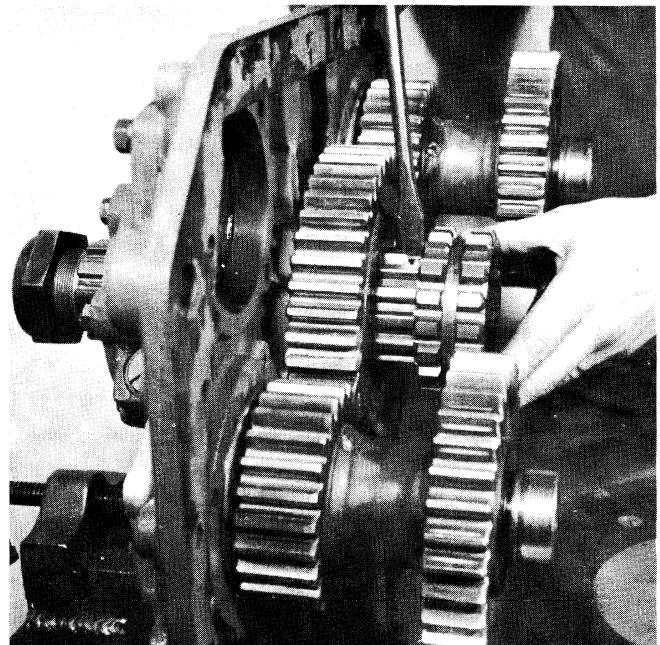

**3. Use a screwdriver to hold the tension ball down and slide the sliding clutch on the shaft and over the ball.**

### III. Front Section

#### A. Reassembly and Installation of the Right Reverse Idler Gear Assembly

**NOTE:** Before starting reassembly, check to make sure that all three magnetic discs are in place on the bottom of the case. These can be installed with “3M Brand” adhesive, No. EC1300.



1. Install the plug in the end of the reverse idler shaft.

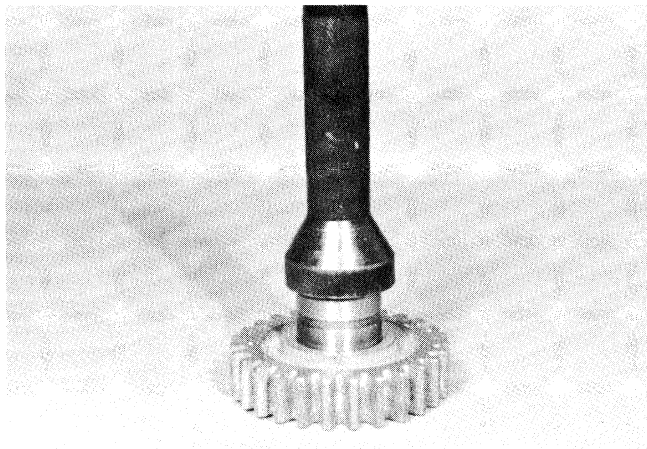

2. If previously removed, press the needle bearing in the bore of the gear.

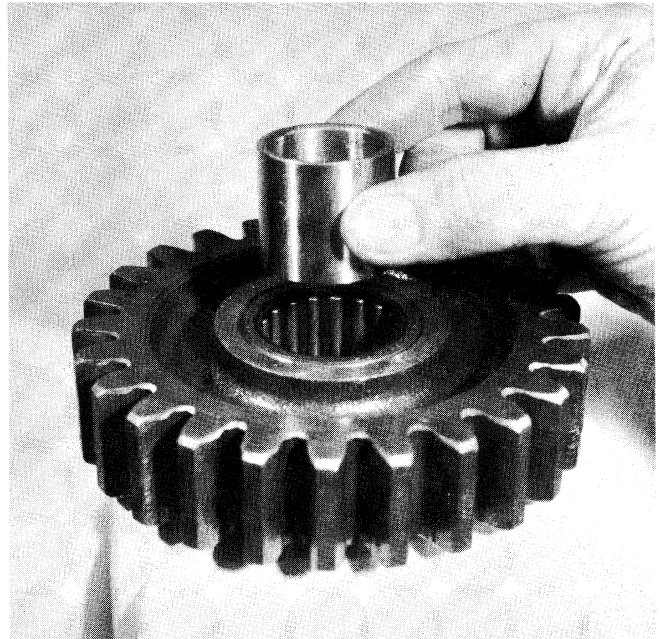

3. Install the bearing inner race in the needle bearing.

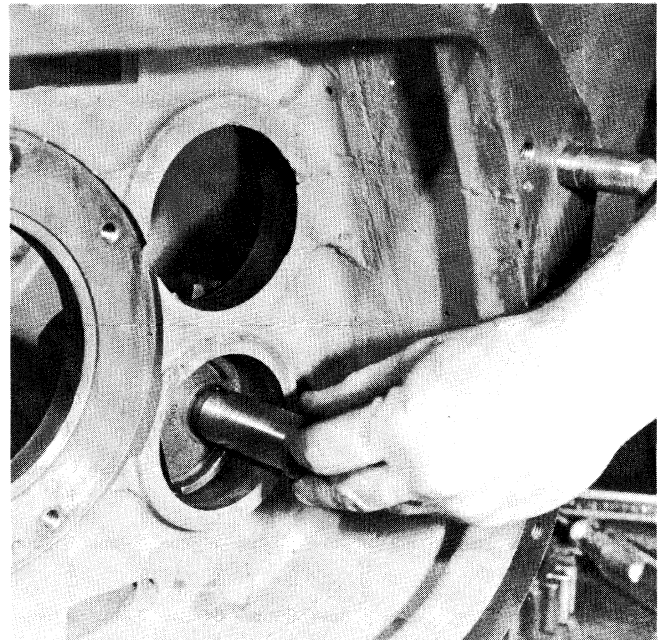

4. Hold the rear washer in place in the case bore and insert the idler shaft into the washer.

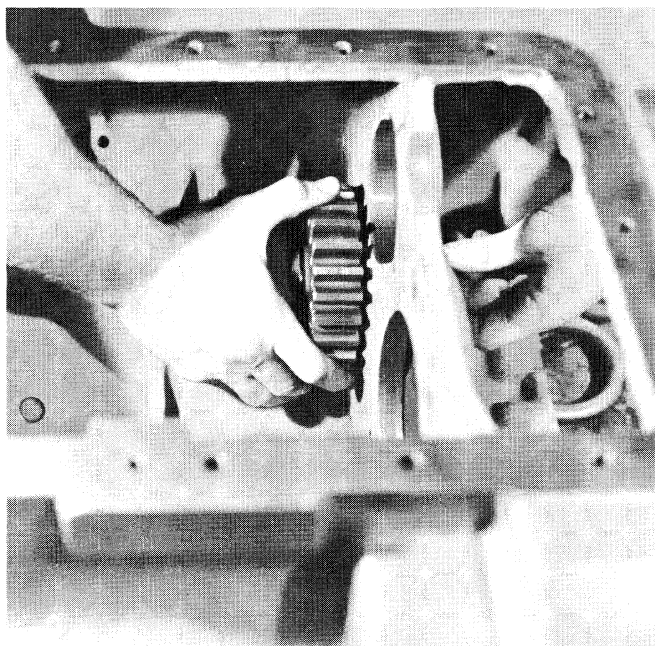

5. Install the gear and thrust washer on the shaft as the shaft is inserted into the case bore.

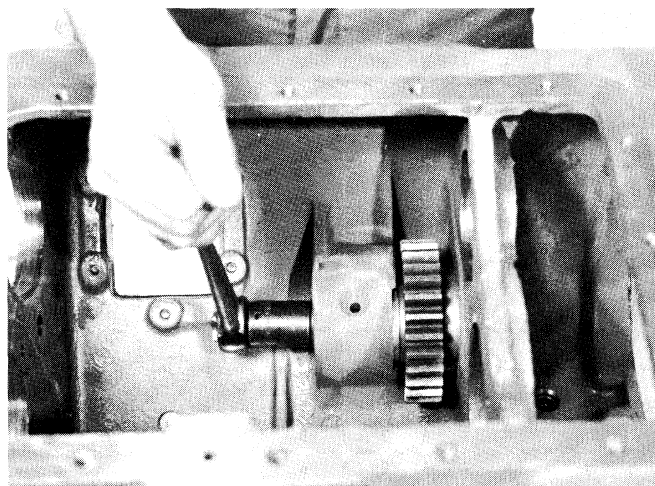

6. Install the elastic stop nut and washer on the end of the shaft.

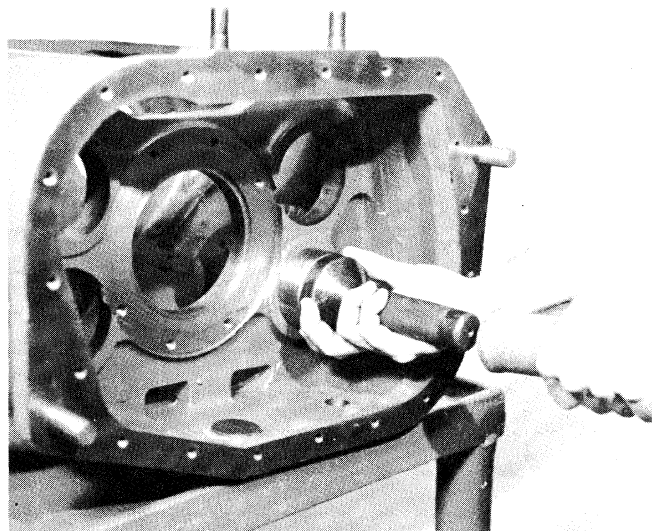

7. Install the auxiliary countershaft front bearing in the reverse idler bore.

**B. Reassembly and Positioning of the Countershaft Assemblies**

**NOTE:** Except for the number of teeth on the PTO gears, the two countershafts are identical and assembled in the same manner.

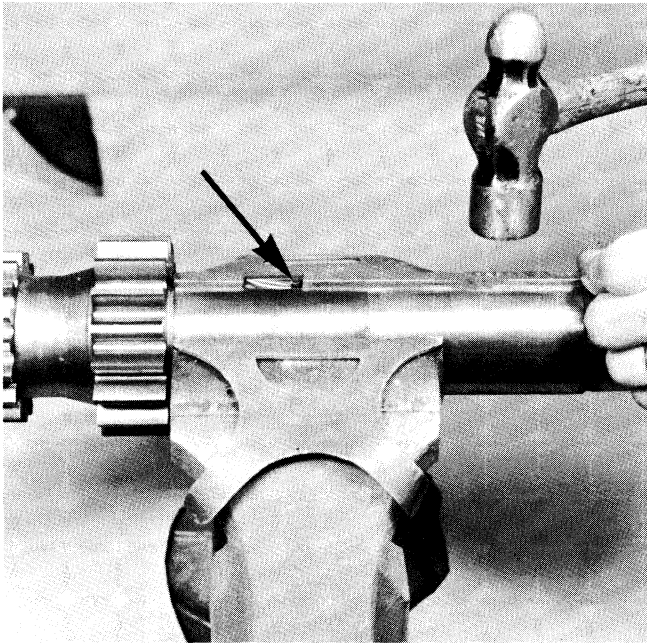

1. If previously removed, install the roll pin and key in each shaft.

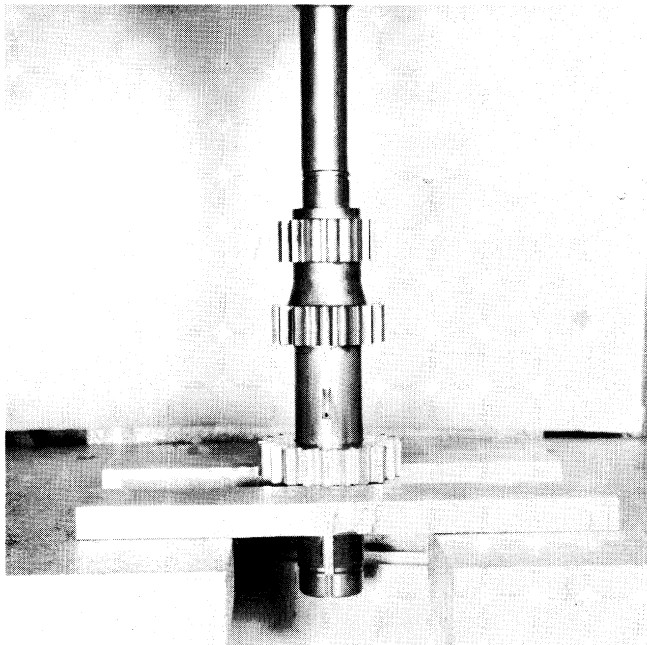

2. Press the 3rd speed gear on the shaft, long hub down.

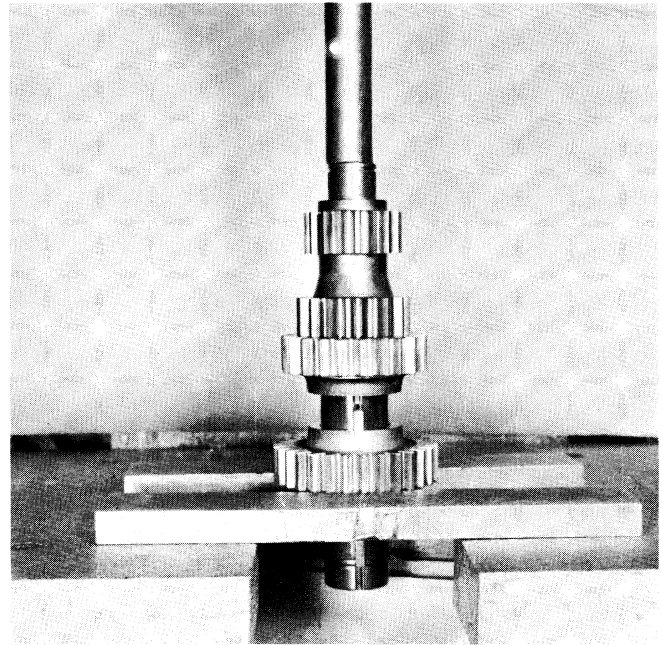

3. Press the 4th speed gear on the shaft, long hub up.

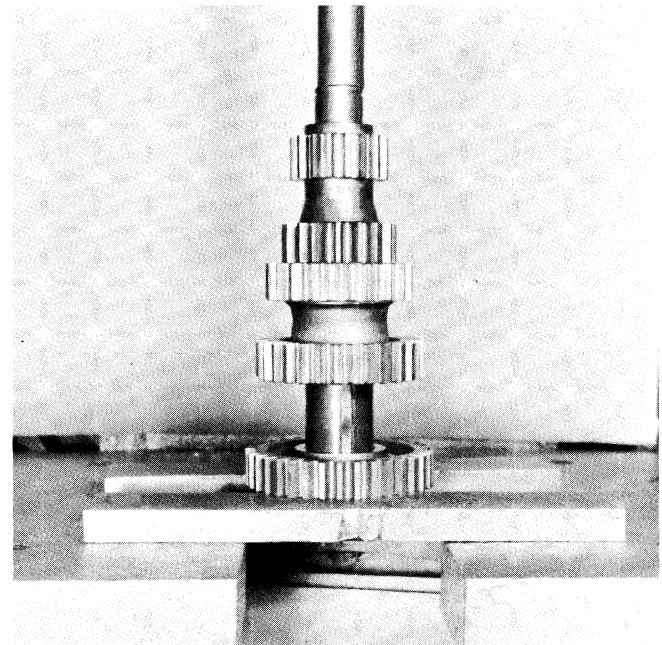

4. Press the 5th speed gear on the shaft, long hub down.

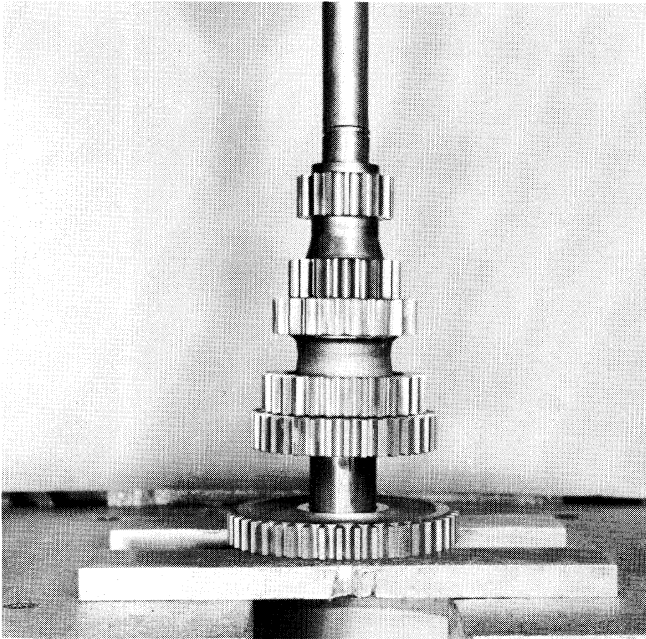

5. Press the PTO gear on the shaft, bullet nose of teeth facing up.

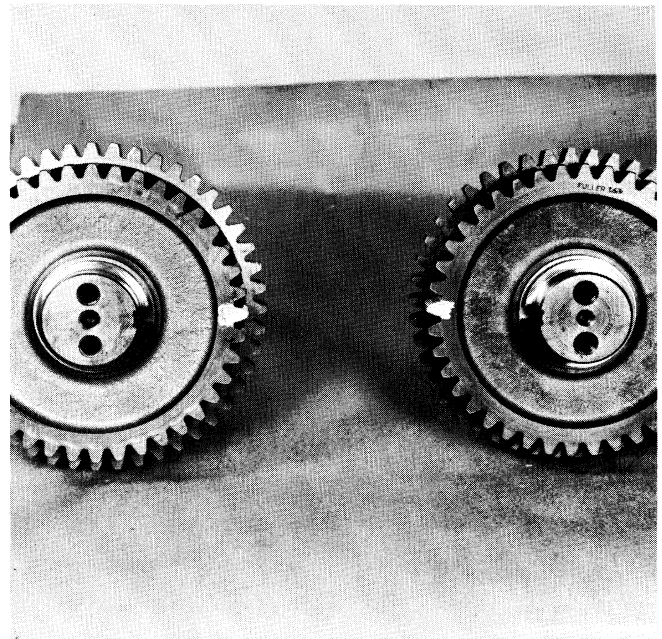

7. Mark the timing tooth on each countershaft drive gear. The tooth is aligned with the keyway and stamped with an "0".

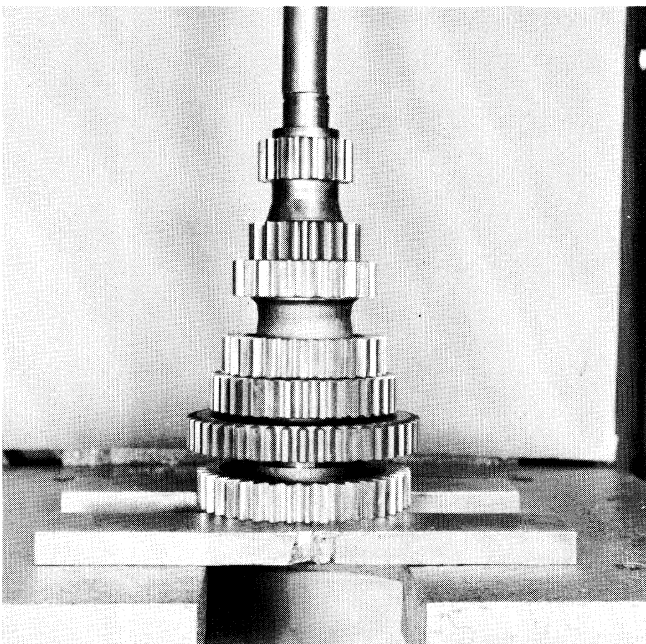

6. Press the 6th speed gear on the shaft, long hub up.

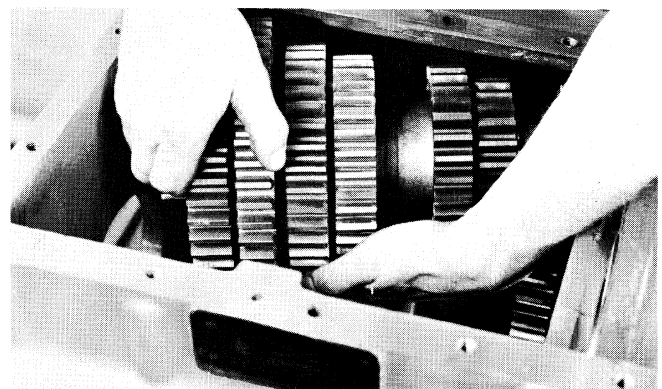

8. Place the left countershaft assembly (47-tooth PTO gear) into position in the case and then place the right (45-tooth PTO gear) into position. Do not install bearings.



C. Reassembly and Installation of the Drive Gear Assembly

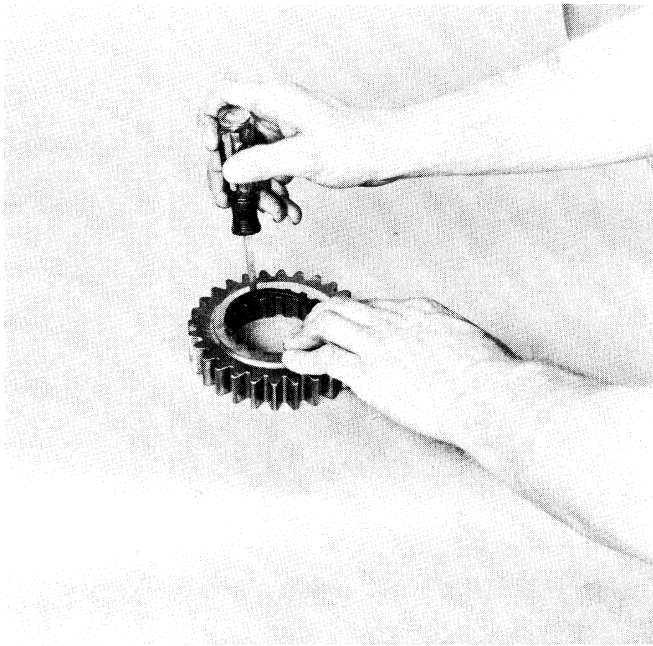

1. Install the snap ring in the ID of the drive gear.

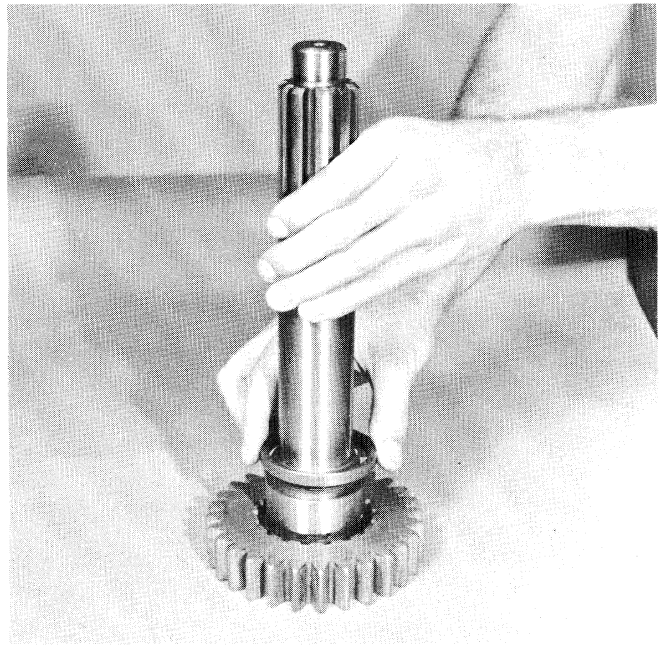

3. Install the spacer on the shaft and against the snap ring.

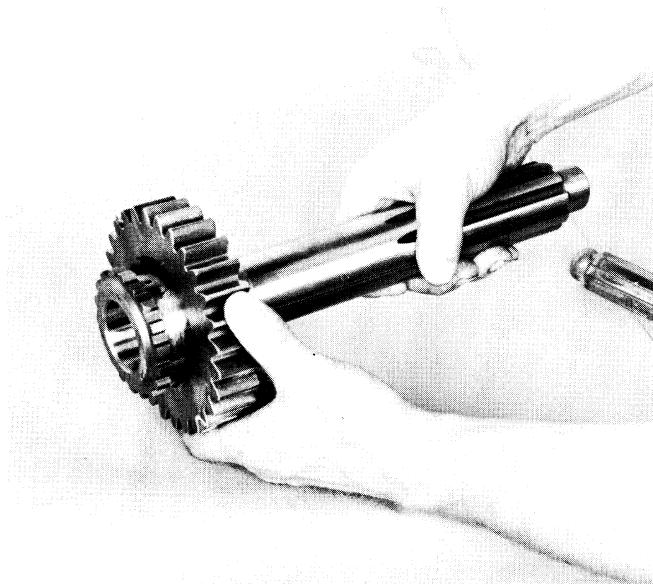

2. Install the drive gear on the splines of the input shaft, snap ring towards the front.

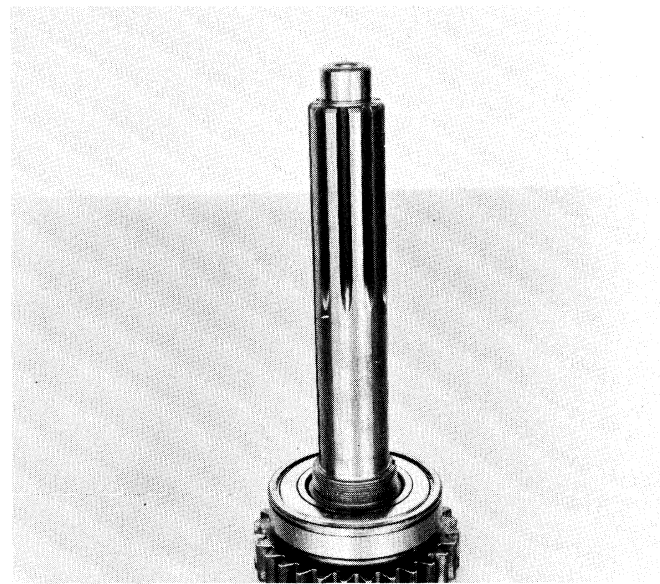

4. Install the drive gear bearing on the shaft; a press fit. Note that the bearing snap ring has been removed.



5. Apply Loctite, grade AVV, to the threads of the drive gear nut. The threads must be dry and free from dirt and grease.

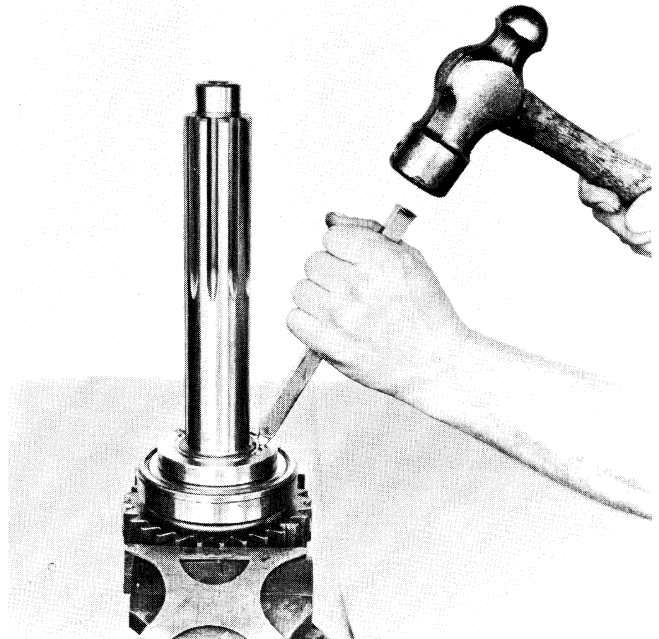

7. Peen the nut into the two slots of the shaft.

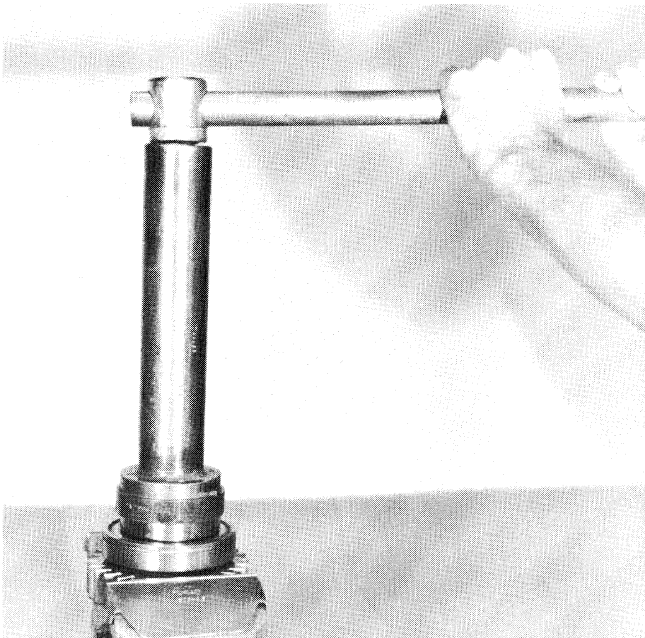

6. Install the drive gear nut on the threads of the input shaft. Use 250-300 ft.-lbs. of torque.

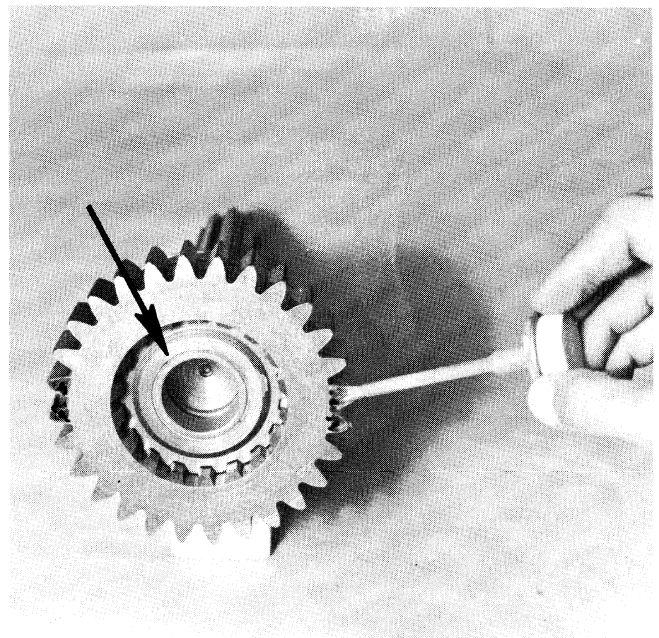

8. Mark any two adjacent teeth on the drive gear and mark the two teeth directly opposite. Check to make sure that the bushing is in place and in good condition.

NOTE: If bushing is to be replaced, press bushing flush into shaft pocket. If the three oil holes are restricted by bushing, drill out with 5/32" drill. Radial clearance between bushing and pilot on mainshaft should be .040-.045.

**C. Reassembly and Installation of the Drive Gear Assembly — continued**

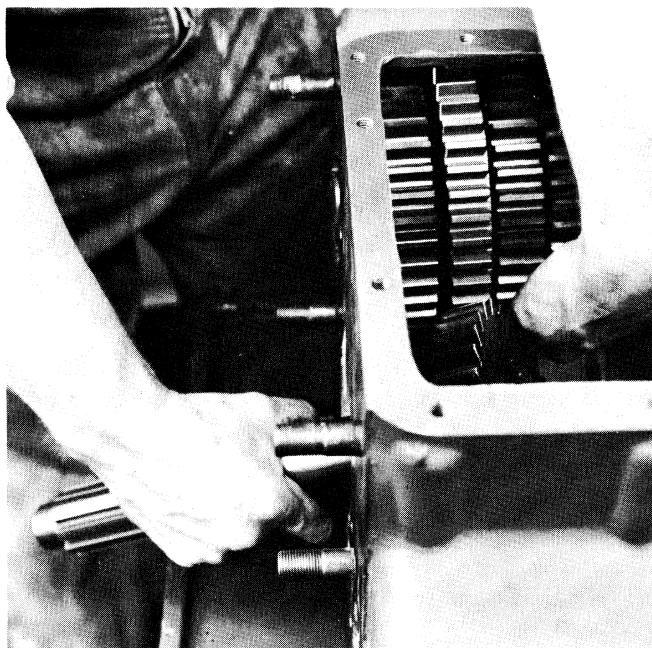

**9. Insert the input shaft through the bore from inside the case, working the drive gear past the countershaft gears to seat the bearing in the front bore.**



**10. Install the snap ring in the groove in the bearing.**

D. Timing and Final Installation of the Left Countershaft Assembly

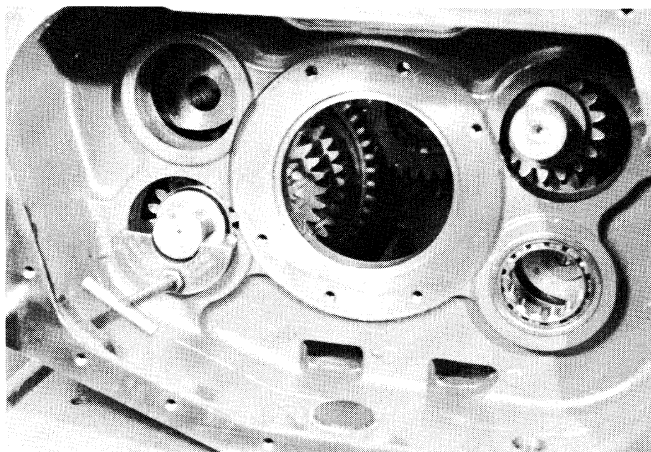

1. Center the rear of the left countershaft in the case bore. If a centering block is not available, use wooden blocks or equivalent.

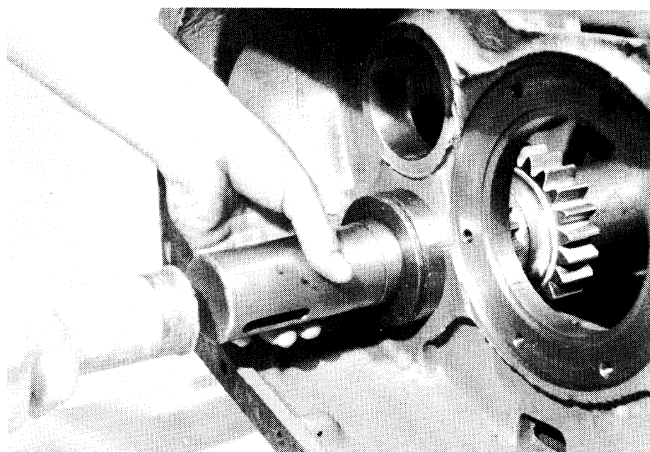

4. Remove the block and install the rear bearing on the shaft and in the case bore.

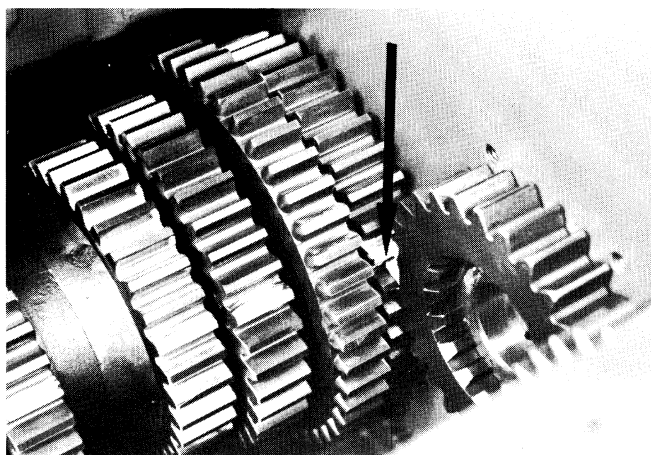

2. Mesh the marked tooth on the countershaft gear between two of the marked teeth on the drive gear.

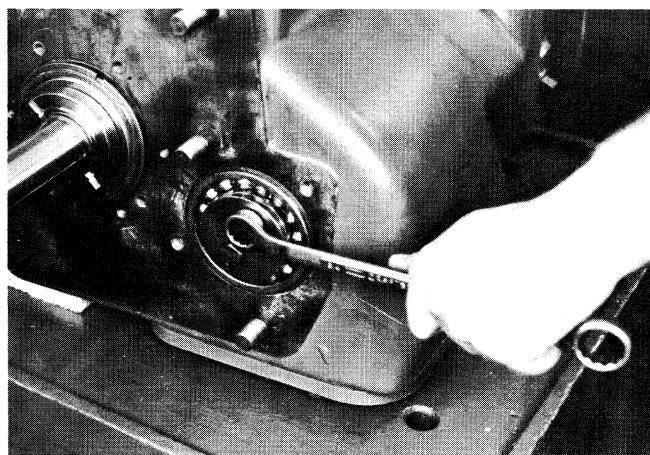

5. Install the bearing retainer plate on the front of the shaft; tighten and wire securely.

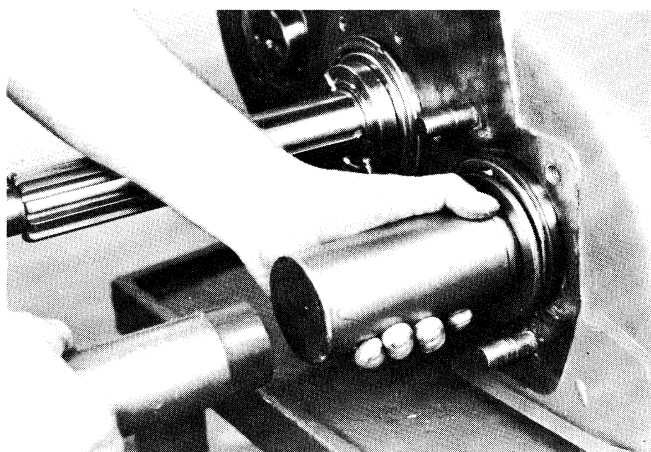

3. Use a bearing driver to install the front bearing on the shaft and in the case bore.

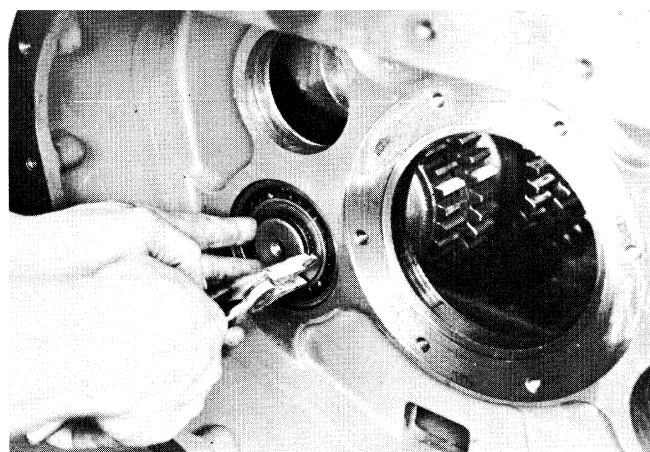

6. Install the snap ring in the groove at the rear of the countershaft.

E. Reassembly and Installation of the Mainshaft Assembly

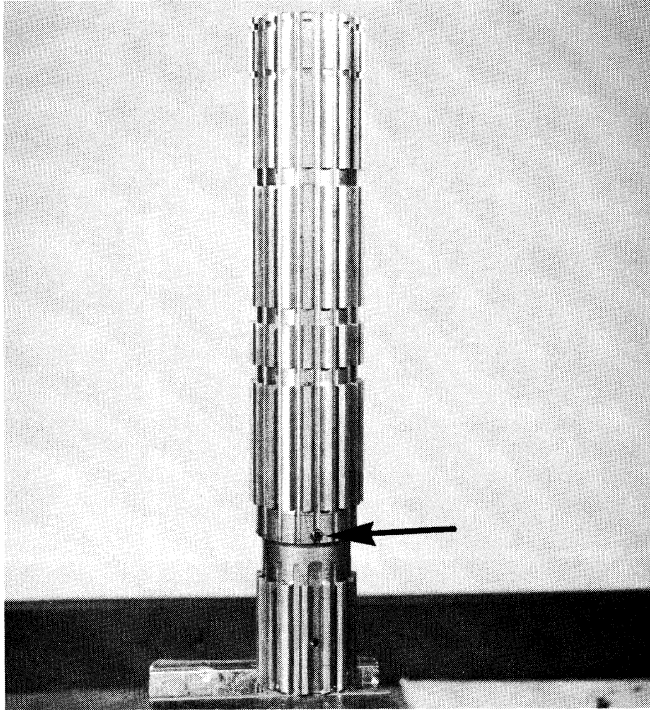

1. Secure the mainshaft in a vise with the pilot (front) end down. Make sure that the roll pin is in place in the keyway.

**NOTE:** Unless otherwise specified, the large notch on each washer should be installed on the opposite side of the shaft from the keyway.

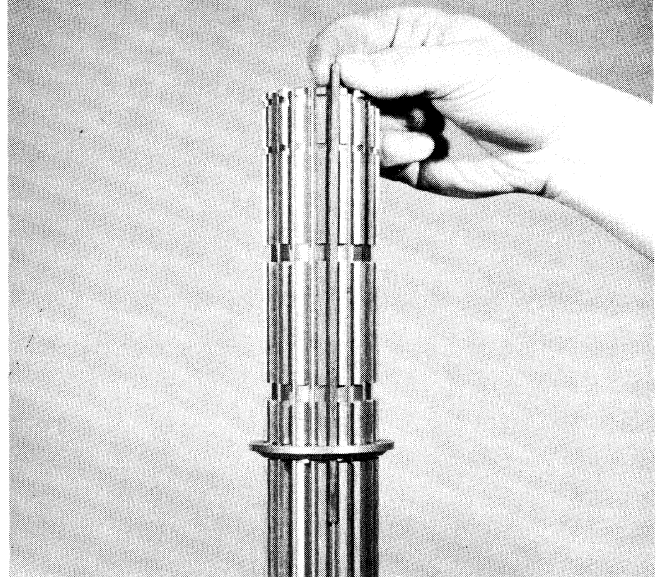

3. Turn the washer on the shaft until a notch aligns with the keyway and install the key in the keyway.

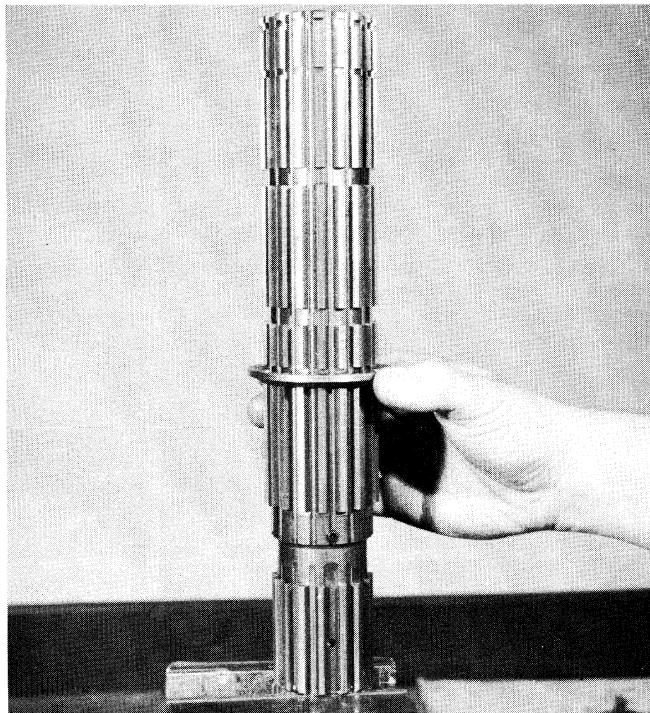

2. Install the 3rd speed gear splined washer on the shaft, flat side up.

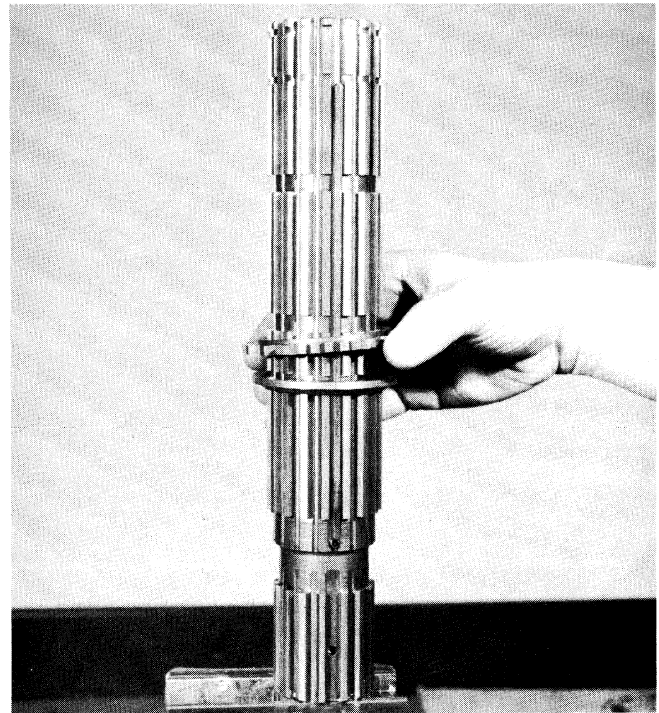

4. Install the splined spacer on the shaft, flat side against the washer.

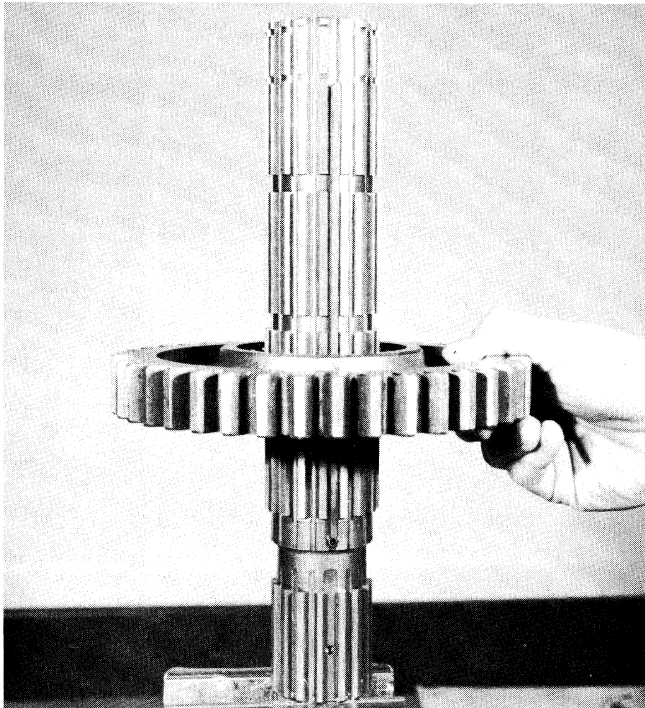

5. Install the 3rd speed gear on the shaft, clutching teeth down and engaging the splines of the spacer.

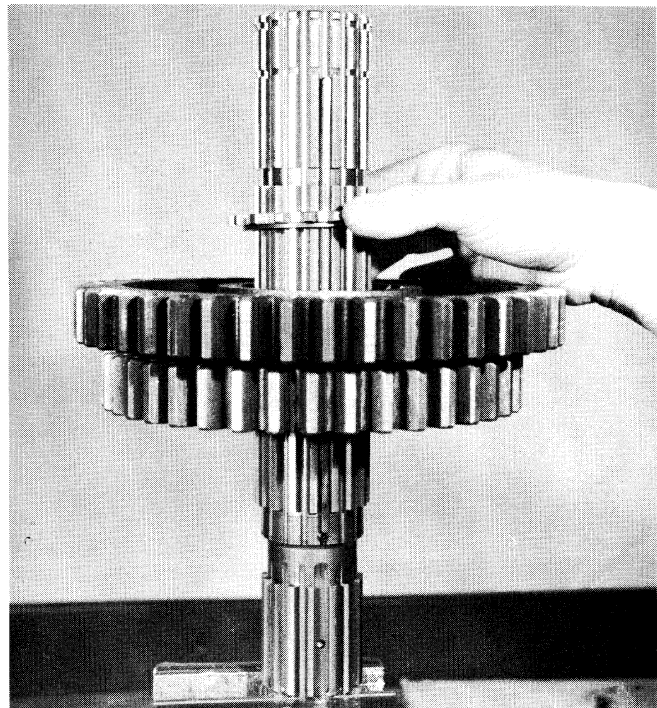

7. Install the 2nd speed splined spacer on the shaft and in the hub of the gear with the flat side up.



6. Place the 2nd speed gear on the 3rd speed gear, clutching teeth up.

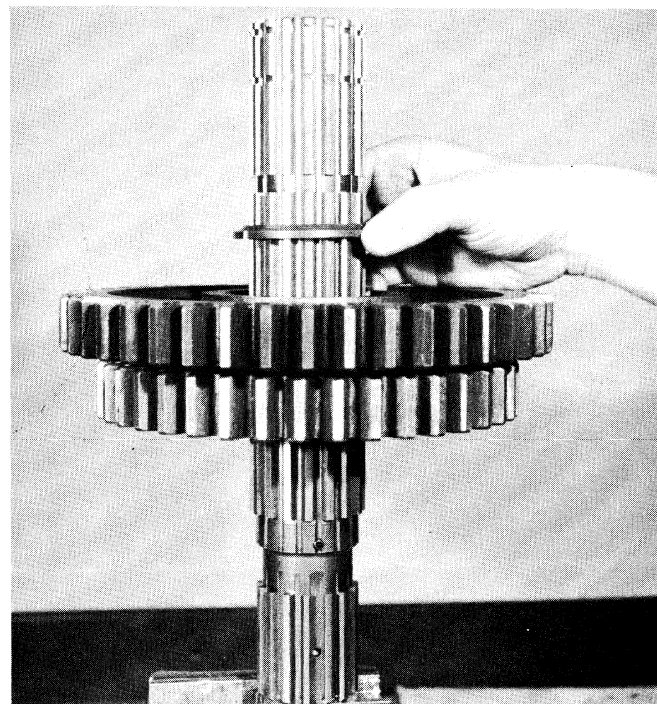

8. Remove the key and install the washer, flat side down, in the hub of the gear and turn until a notch aligns with the keyway.

E. Reassembly and Installation of the Mainshaft Assembly — continued

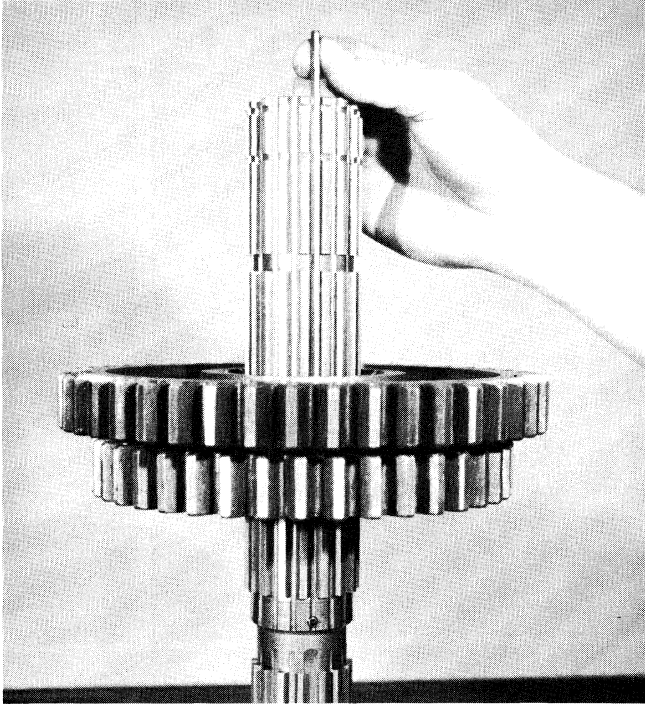

9. Install the key in the keyway.

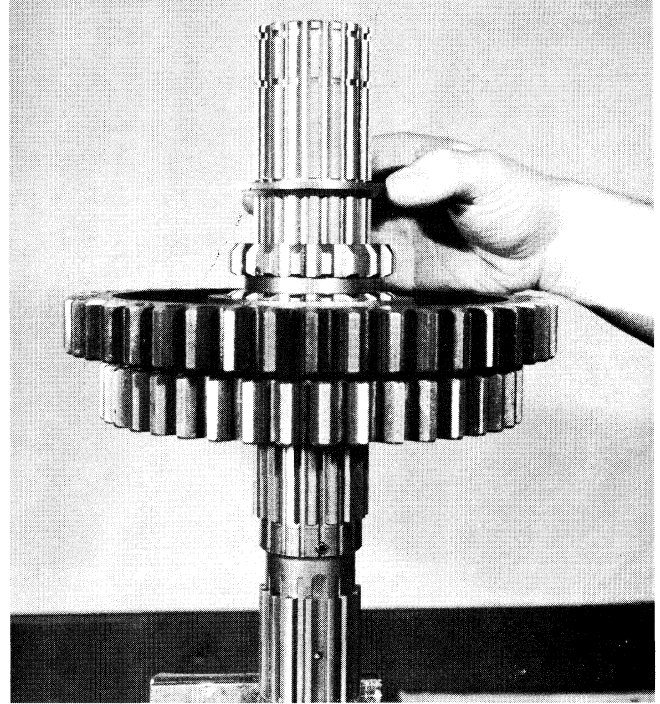

11. Remove the key and install the reverse gear splined washer on the shaft, flat side up.

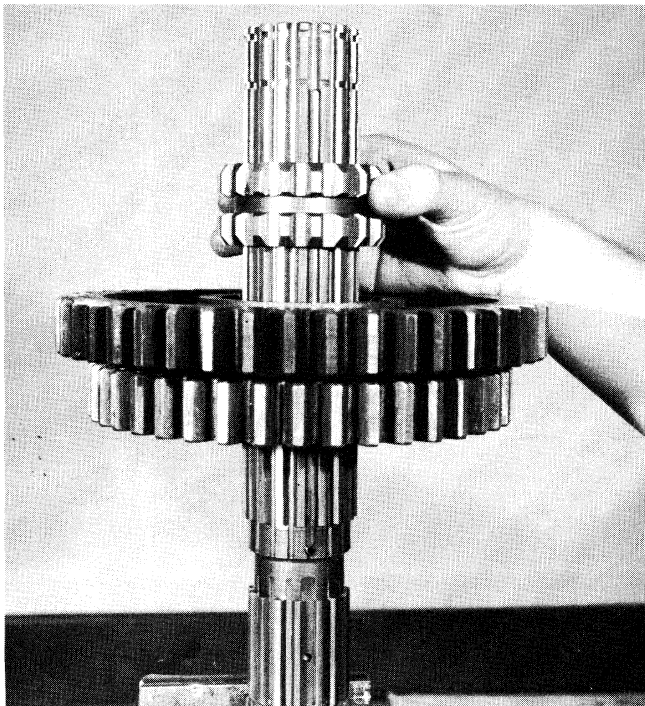

10. Install the 2nd-reverse speed sliding clutch on the shaft with the large notch over the keyway.

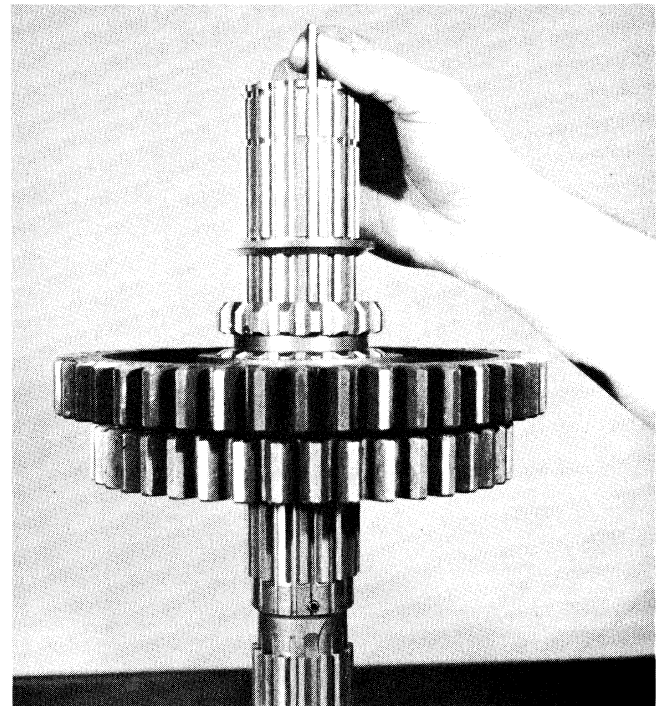

12. Turn the washer on the shaft until a notch aligns with the keyway and reinstall the key.

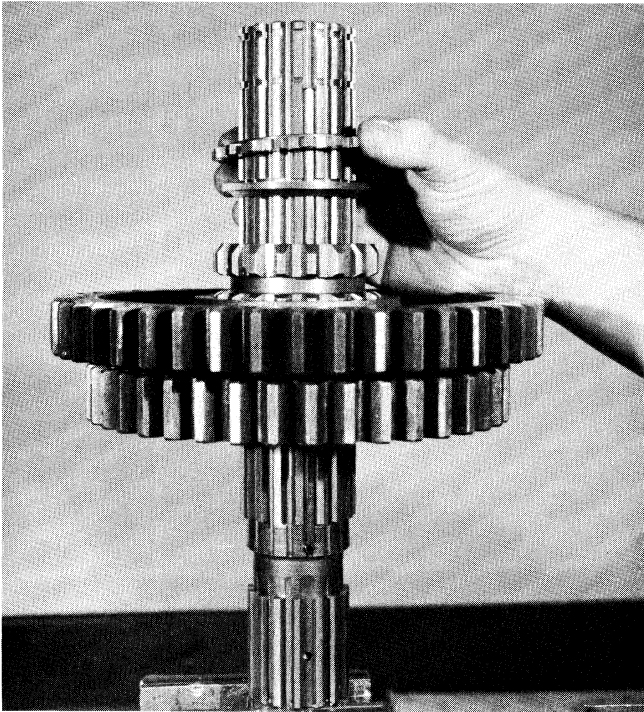

13. Install the spacer on the shaft and against the washer, flat side down.

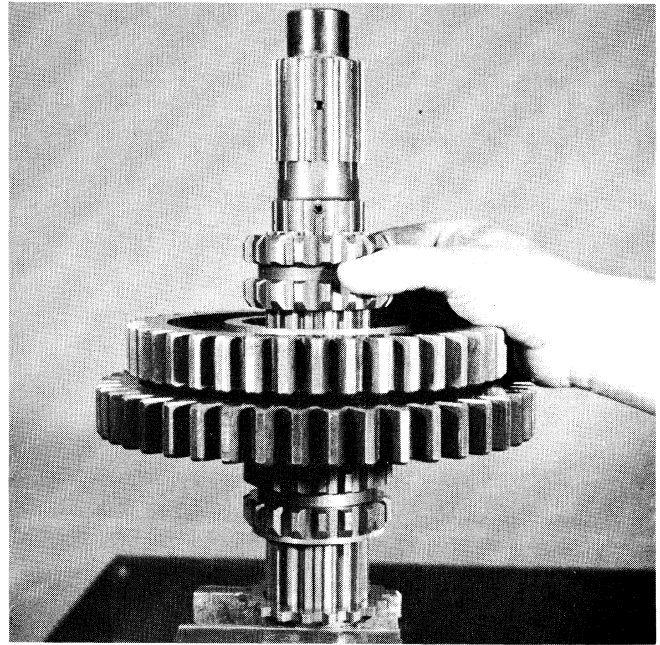

15. Remove the assembly from the vise and reinstall in the vise with the pilot (front) end up. Install the 3rd-4th speed sliding clutch on the shaft with the large notch over the keyway.

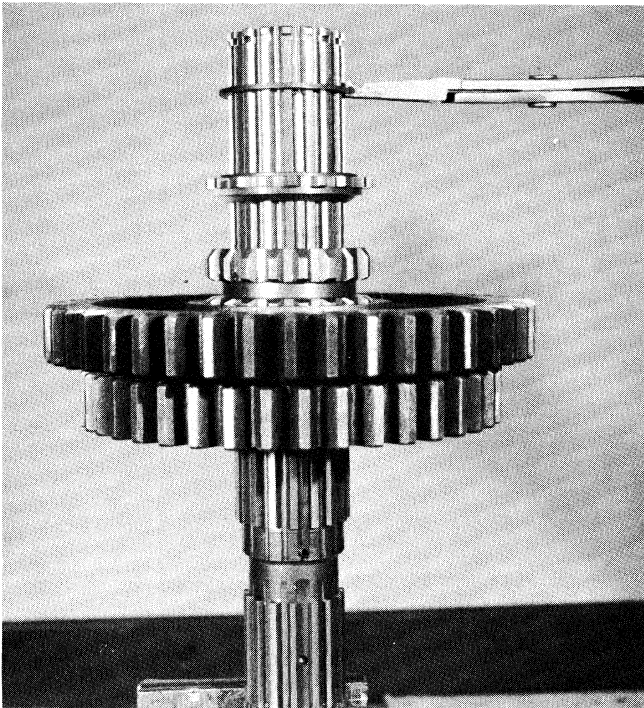

14. Install the snap ring in the groove in the mainshaft behind the end of the key.

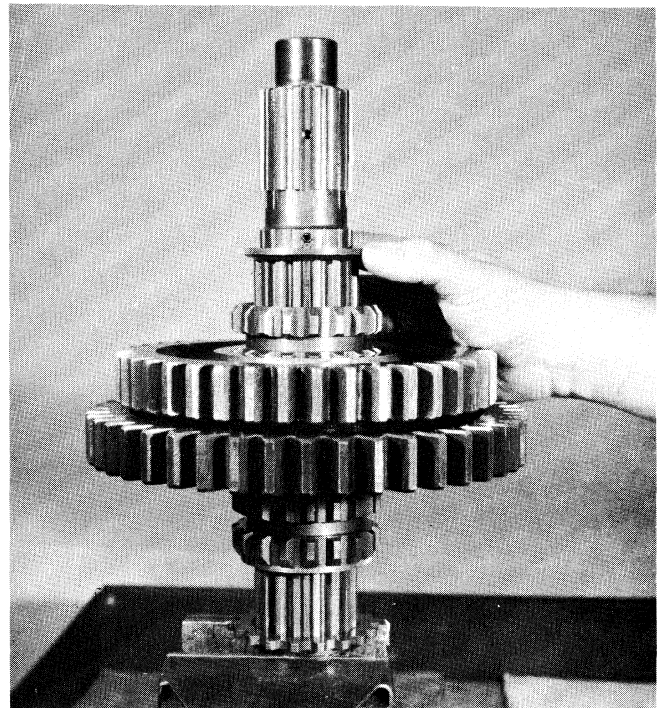

16. Install the 4th speed gear washer on the shaft with one notch fitting over the key and resting on the shoulder of the shaft. The flat side should face up.



E. Reassembly and Installation of the Mainshaft Assembly — continued

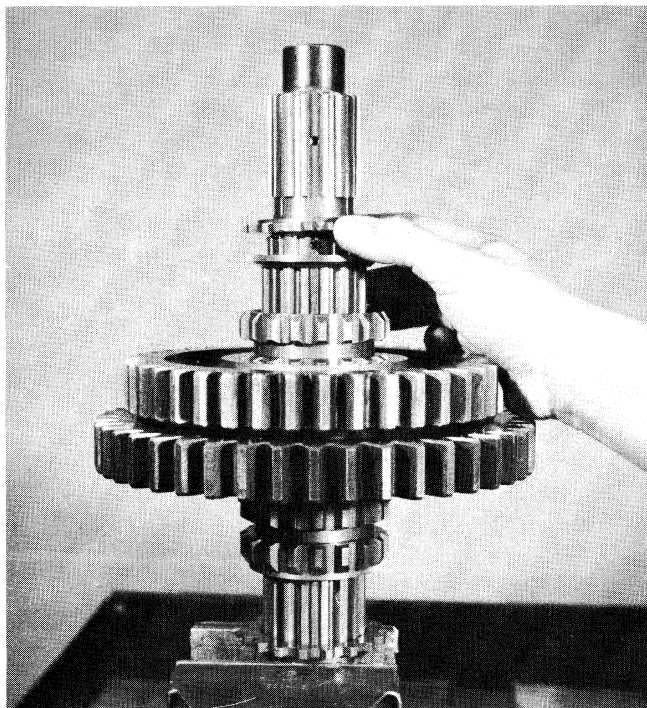

17. Install the spacer on the shaft, flat side down.

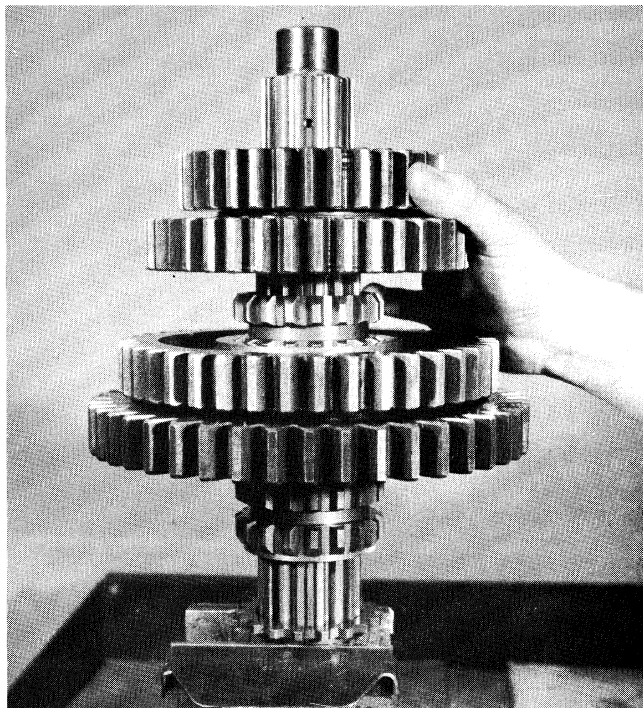

19. Place the 5th speed gear on the 4th speed gear, clutching teeth up.

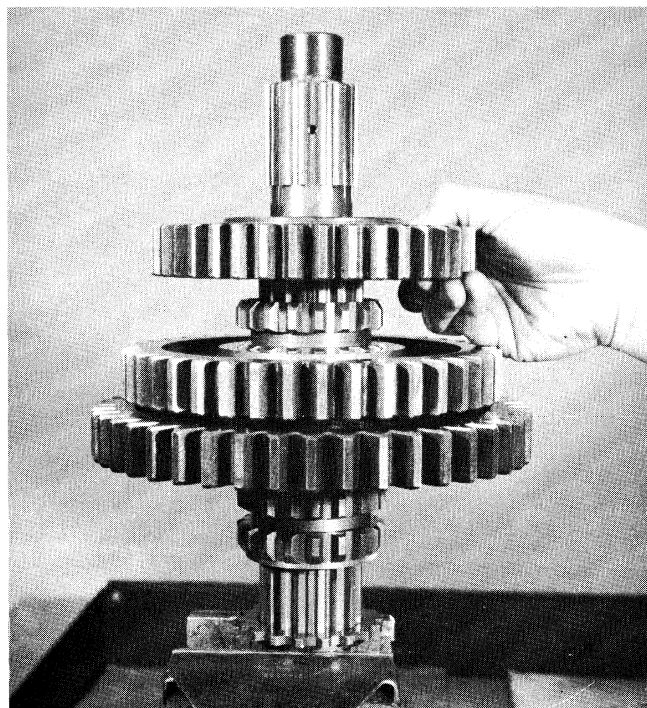

18. Place the 4th speed gear on the shaft, clutching teeth down and engaging the splines of the spacer.

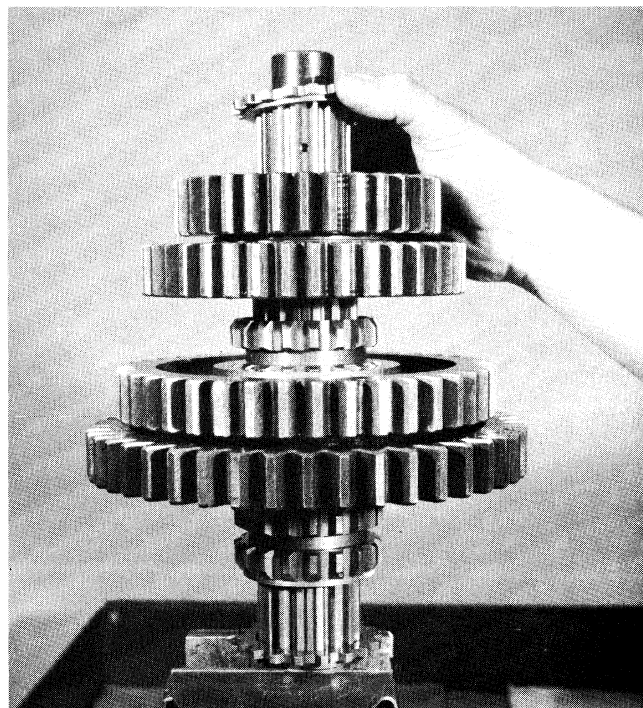

20. Install the spacer, flat side up, on the shaft and in the hub of the 5th speed gear.

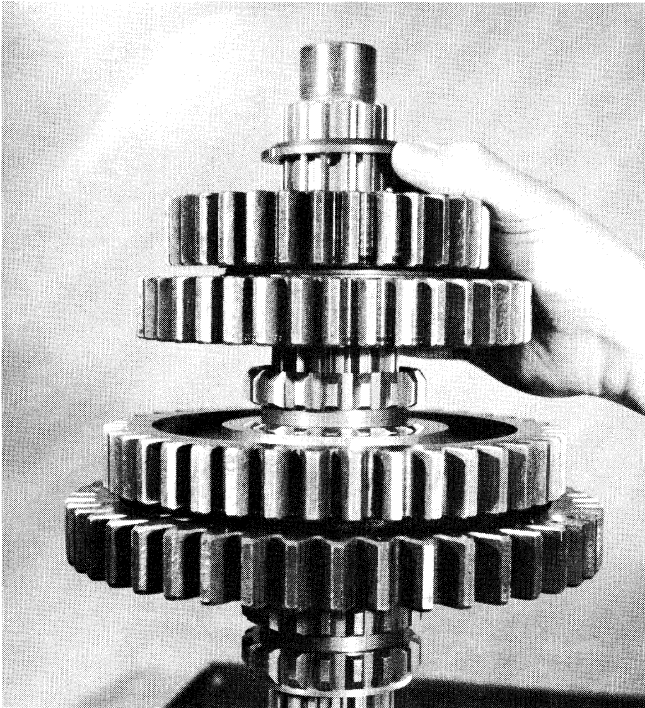

21. Install the washer on the shaft and in the hub of the gear with the flat side down.

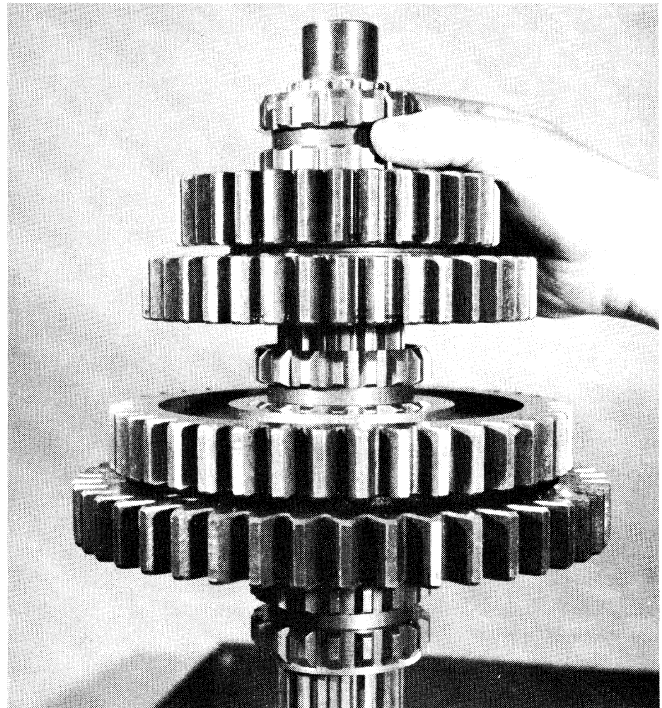

23. Install the 5th-6th speed sliding clutch on the shaft with the large notch over the key.

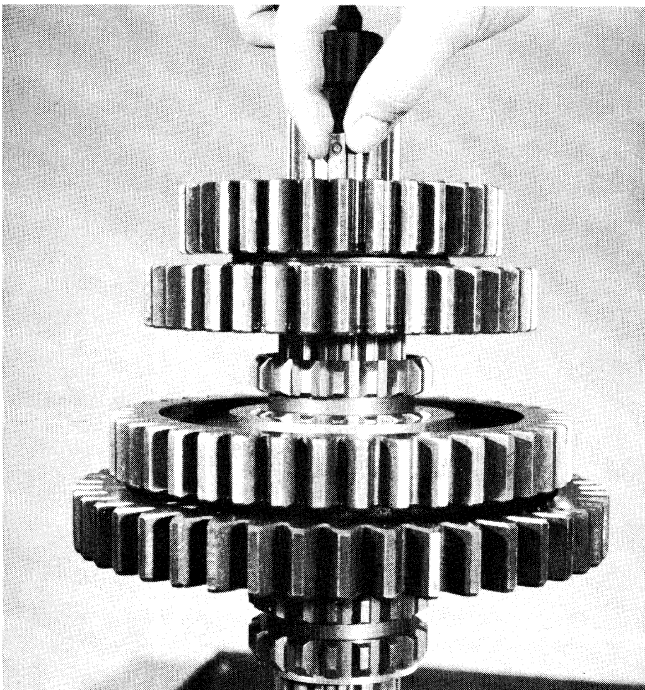

22. Align the large notch of the washer with the keyway and install the key, fitting the tapered end in the washer notch and the pin in the hole in the keyway.

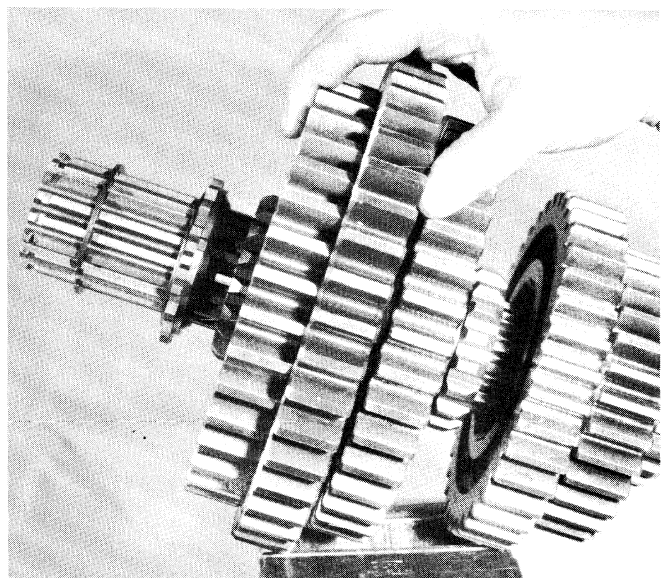

24. Remove the assembly from the vise and install the reverse speed gear on the shaft with the clutching teeth forward and engaging the splines of the sliding clutch. Engage the clutch in the 2nd speed gear so that the reverse and second speed gears are as close together as possible.

**E. Reassembly and Installation of the Mainshaft Assembly – continued**

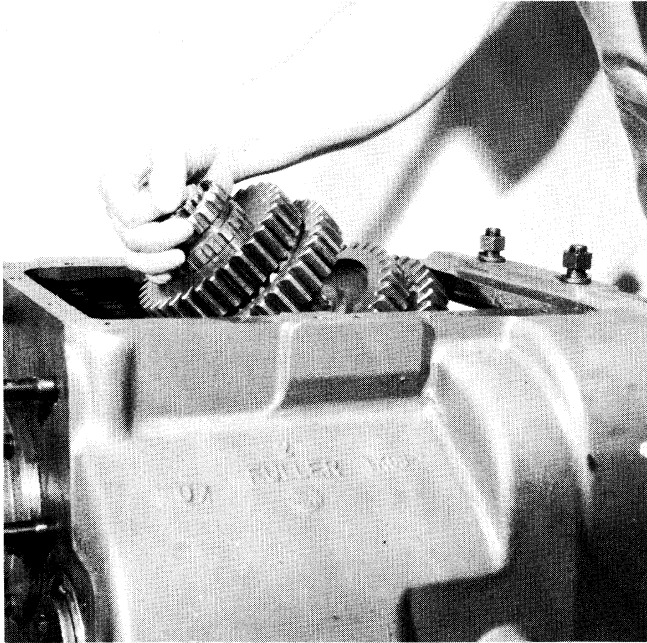

**25. From inside the case, insert the rear of the mainshaft through the rear bearing bore and lower the assembly into position. Use caution as the reverse gear is free and can fall from the mainshaft.**

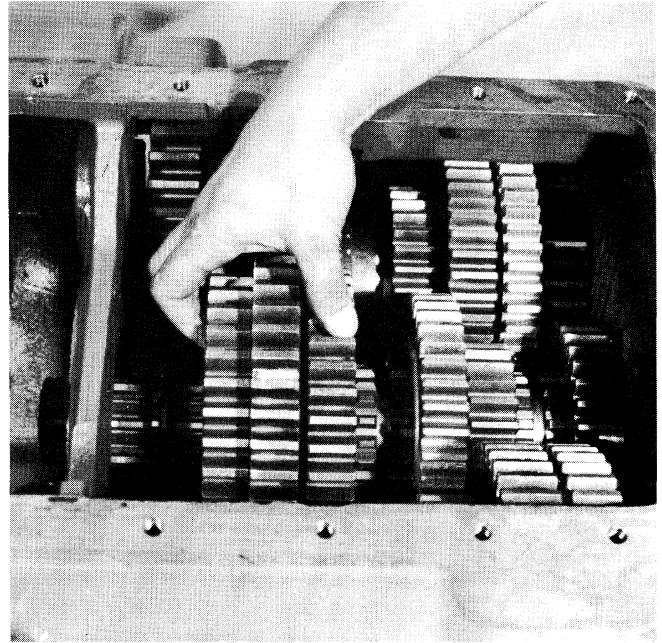

**26. Move the mainshaft assembly forward to seat the pilot end of the shaft in the bushing in the input shaft.**

F. Timing and Installation of the Right Countershaft Assembly



1. Mesh the timing tooth on the right countershaft between the two timing teeth on the drive gear, making sure that the left countershaft timing tooth is still meshed between the other two drive gear timing teeth.

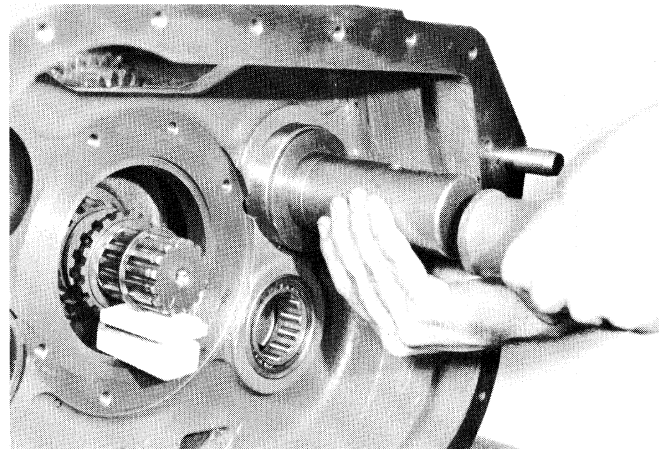

4. Install the rear bearing on the shaft and in the case bore.

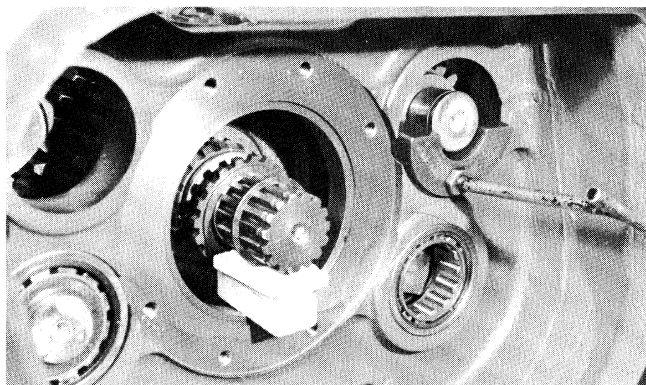

2. Center the rear of both the mainshaft and countershaft in the case bores. **ACCURATE CENTERING OF THE MAINSHAFT IS IMPORTANT.**

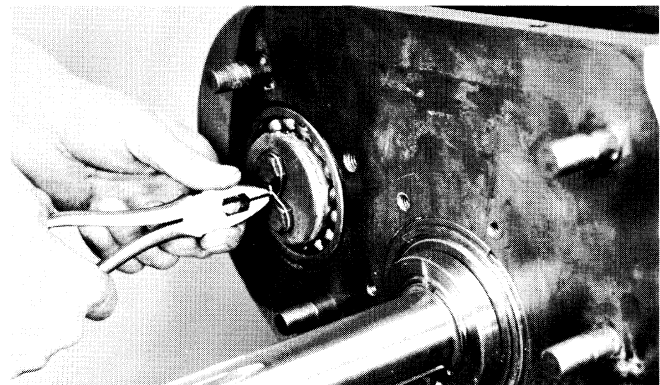

5. Install the bearing retainer plate on the front of the shaft and wire securely.

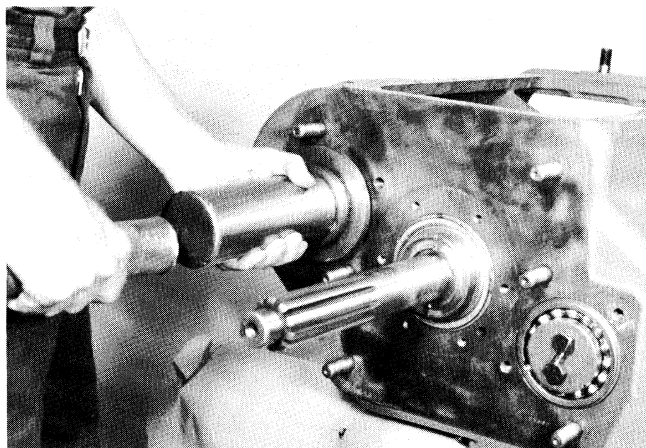

3. Install the front bearing on the countershaft and in the case bore.

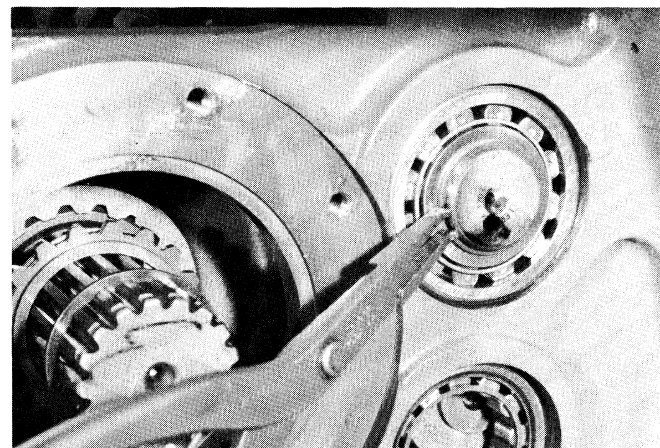

6. Install the snap ring in the groove at the rear of the countershaft.

**G. Reassembly and Installation of the Left Reverse Idler Gear Assembly**



**1. Install the plug in the idler shaft.**

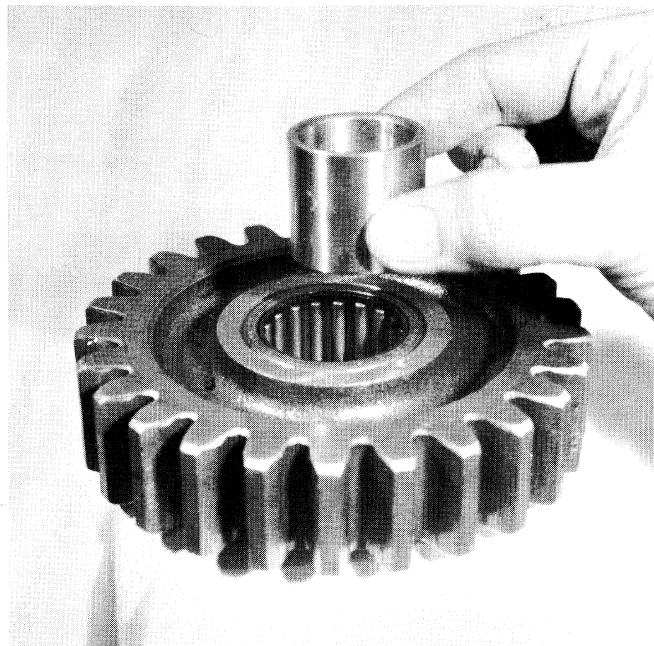

**3. Install the bearing inner race in the needle bearing.**

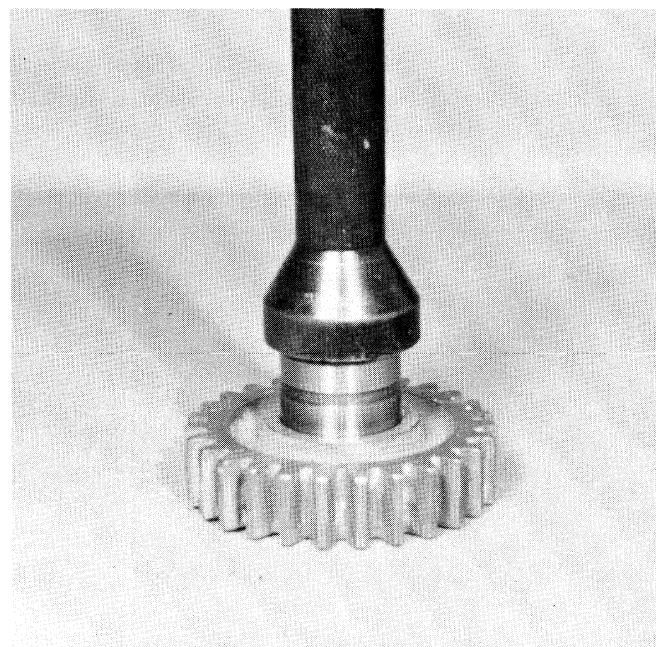

**2. If previously removed, press the needle bearing in the bore of the gear.**

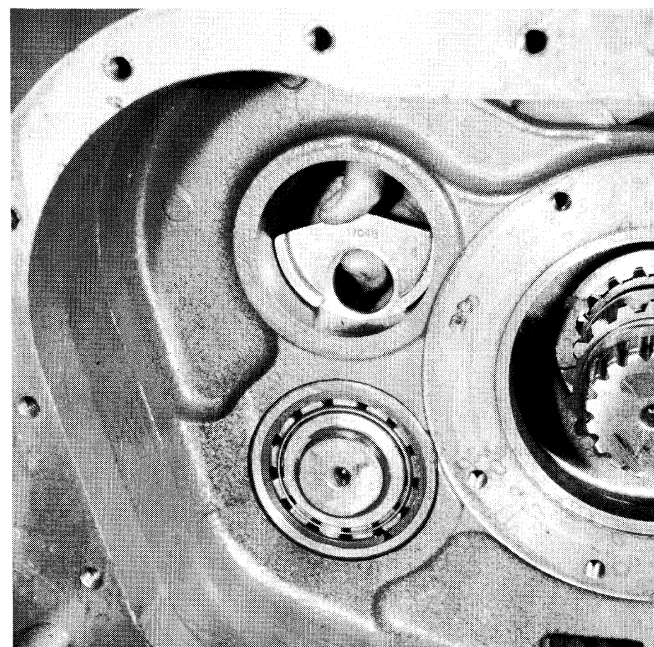

**4. Hold the rear washer in place in the case bore and insert the end of the idler shaft into the washer.**

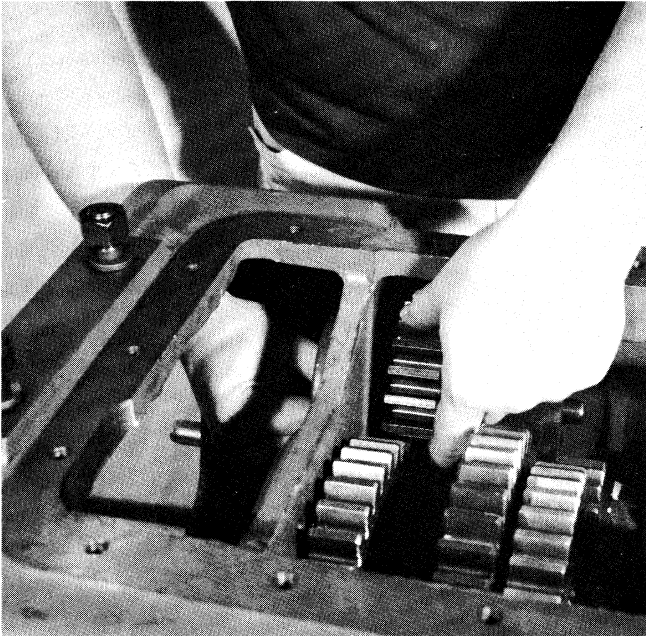

5. Install the gear and thrust washer on the shaft as the shaft is inserted through the case bore.

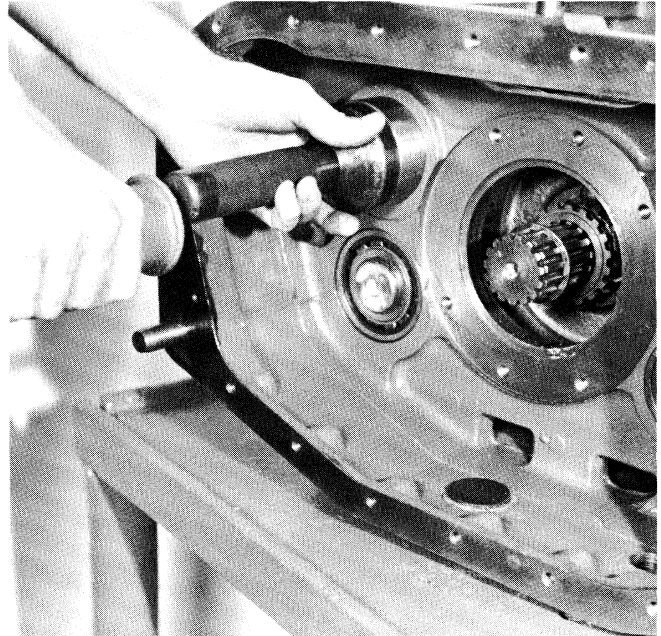

7. Install the auxiliary countershaft front bearing in the reverse idler bore.

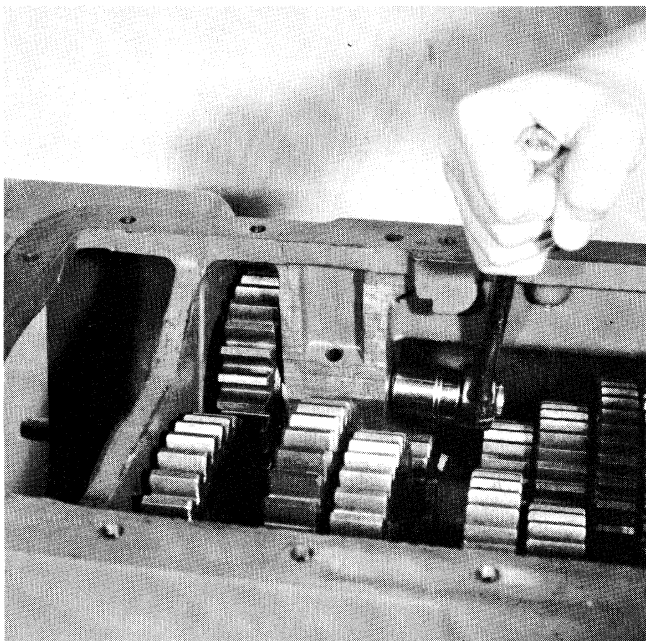

6. Install the elastic stop nut and washer on the end of the shaft.

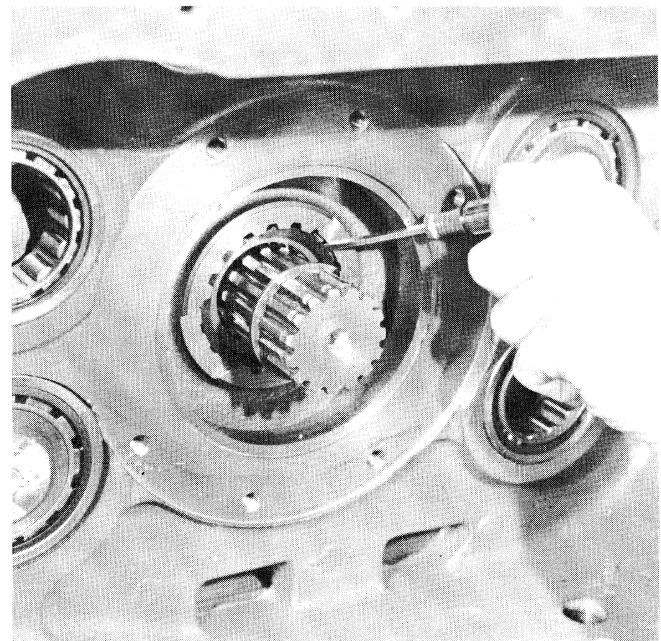

8. Mesh the mainshaft reverse gear with the idler gears and install the snap ring in the ID of the gear.

H. Reassembly and Installation of the Auxiliary Drive Gear Assembly

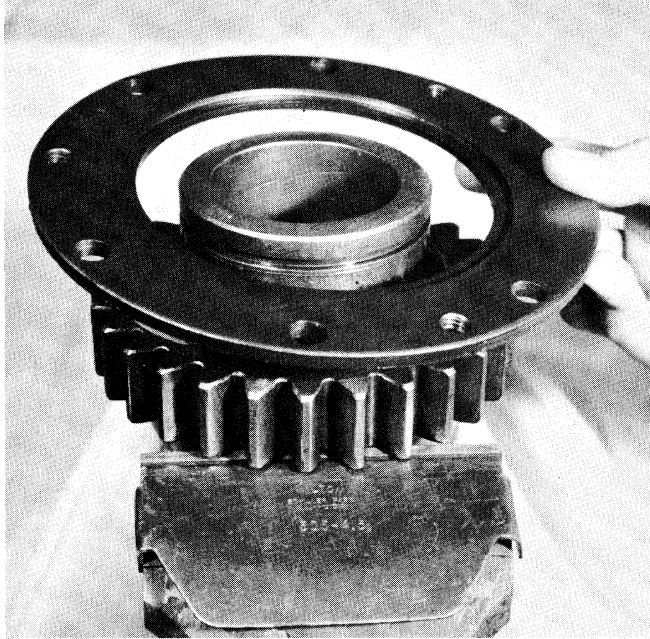

1. Place the retainer ring on the auxiliary drive gear, flat side down.

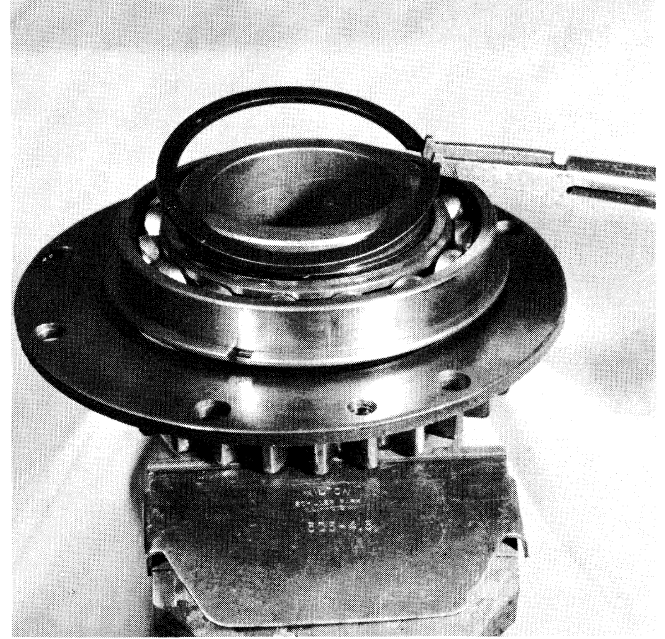

3. Install the snap ring in the groove at the rear of the gear hub.

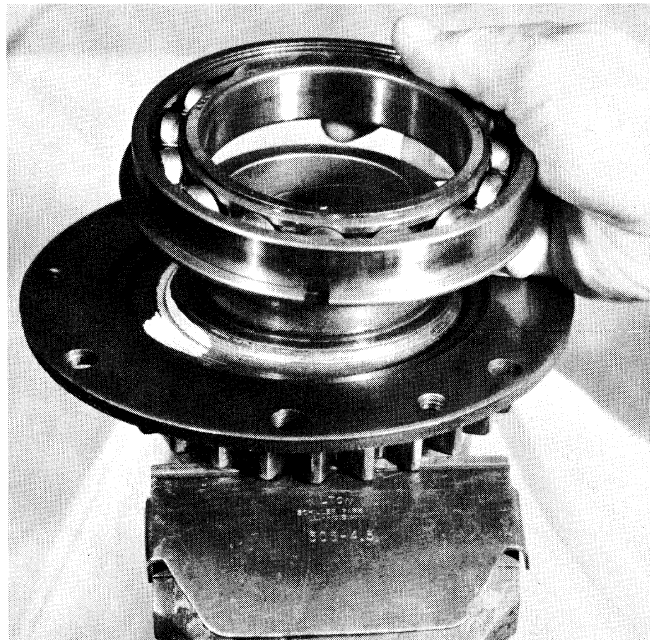

2. Press the bearing on the drive gear with the snap ring against the retainer ring.

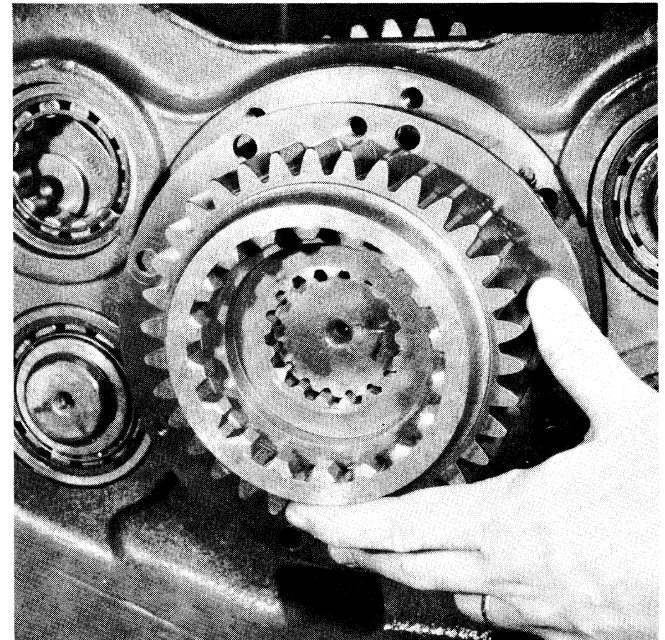

4. Seat the bearing in the rear bore, fitting the drive gear on the splines of the mainshaft.

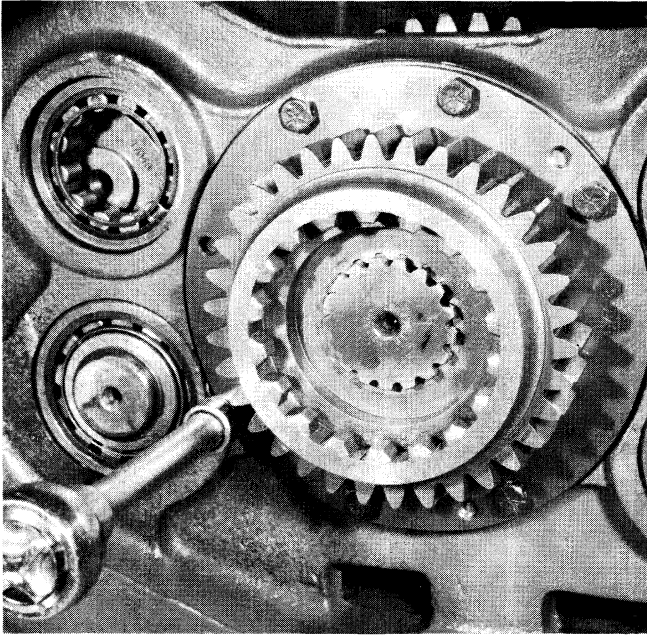

5. Secure the retaining ring to the housing with the six retaining cap screws; tighten and wire securely in sets of three.

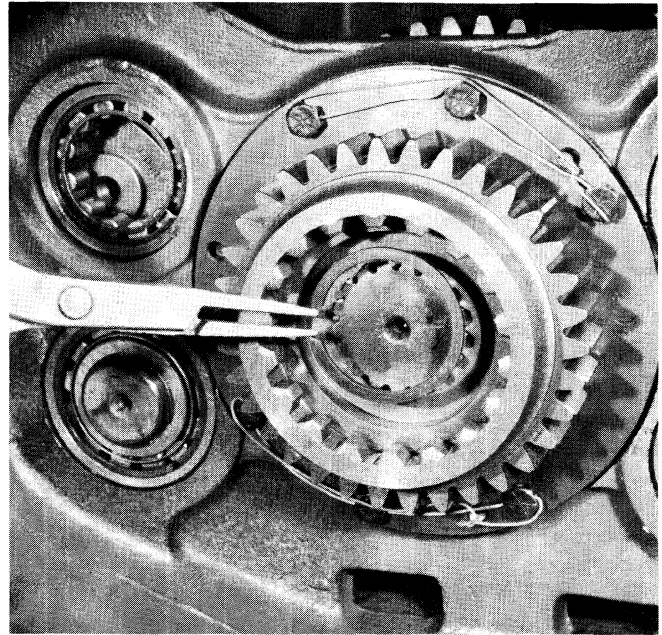

6. Install the rear coupling snap ring in the groove in the rear of the mainshaft.



## IV. Clutch Housing, Companion Flange and Auxiliary Section

### A. Installation of the Clutch Housing

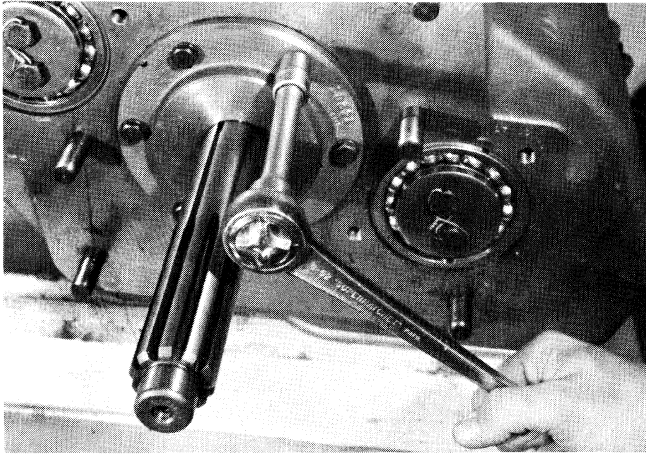

1. Install the front bearing cover, making sure that the notch on the inside of the cover aligns with the oil port in the front case. Secure with the six retaining capscrews.

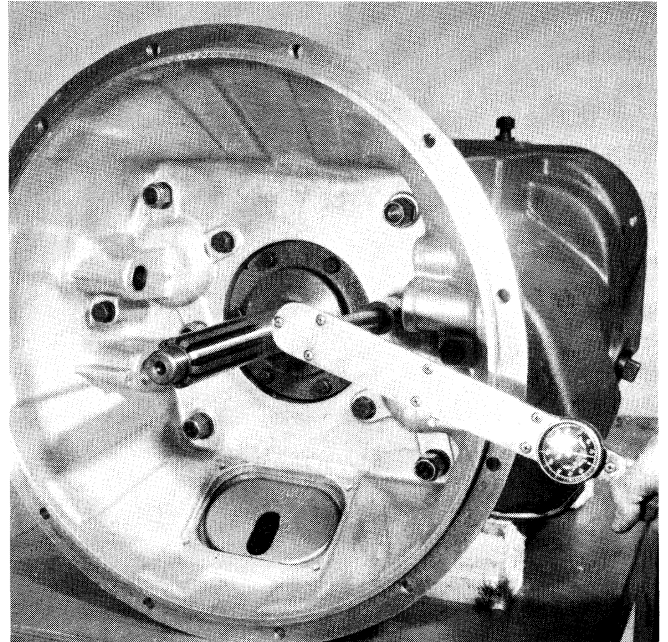

3. Secure the clutch housing to the front case with the six nuts and four bolts. Use correct torque: Nuts - 170-185 ft. lbs.; Bolts - 70-75 ft. lbs. If so equipped, install the upshift clutch brake assembly on the front bearing cover.

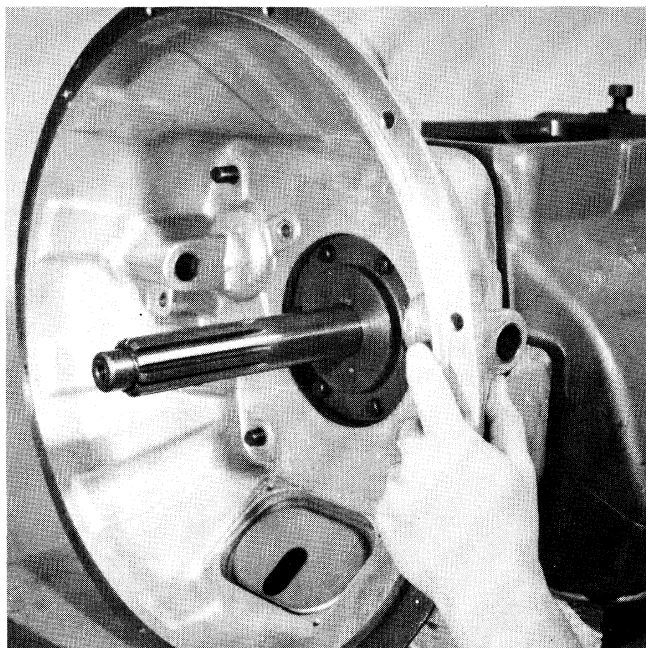

2. Using the front bearing cover as a pilot, install the clutch housing on the front case studs.

**B. Installation of the Auxiliary Rear Housing**

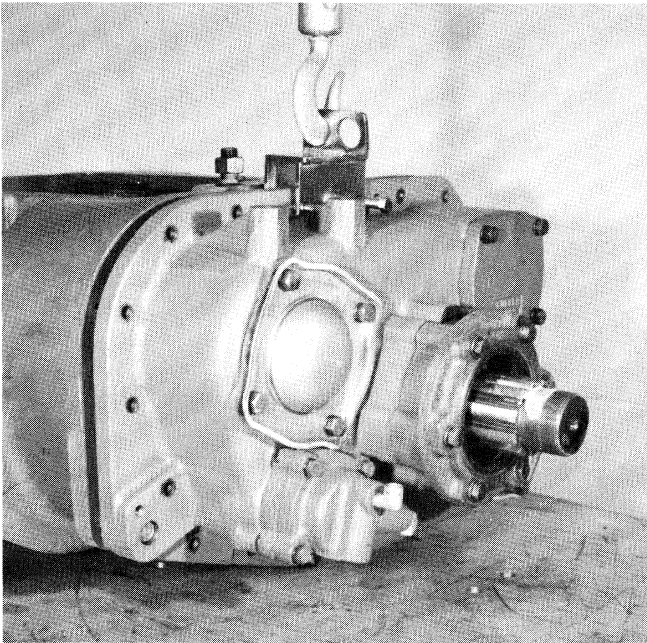

1. Attach a chain hoist to the auxiliary housing and move the assembly on to the front case dowel pins, rotating the input shaft as necessary to mesh the auxiliary countershaft gears with the auxiliary drive gear.

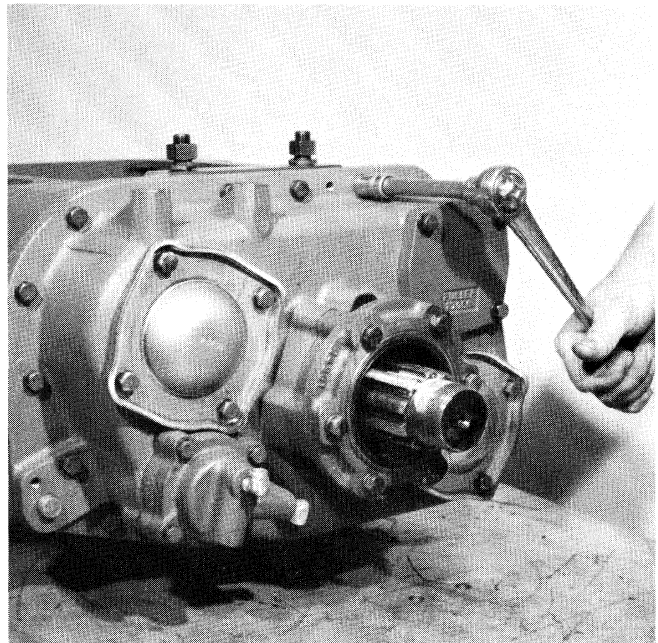

2. Secure the rear housing to the front case with the 19 retaining cap screws.

**C. Installation of the Companion Flange or Yoke**

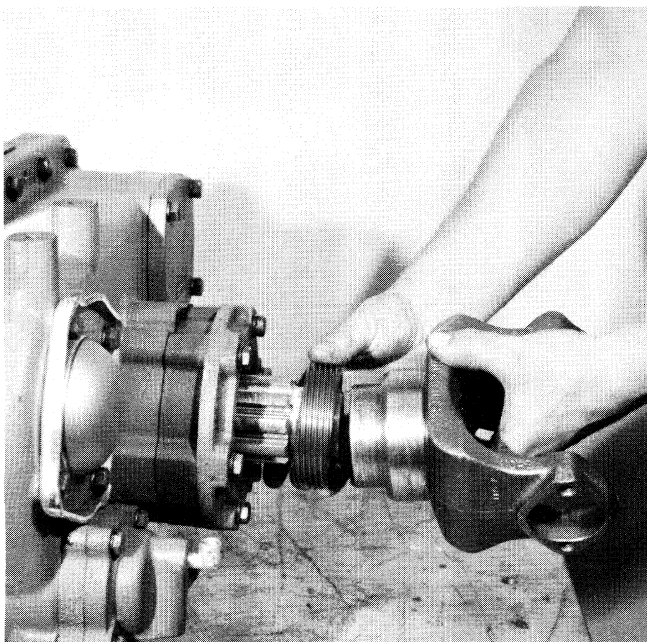

1. Install the speedometer drive gear or spacer and the companion flange or yoke on the splines of the output shaft.

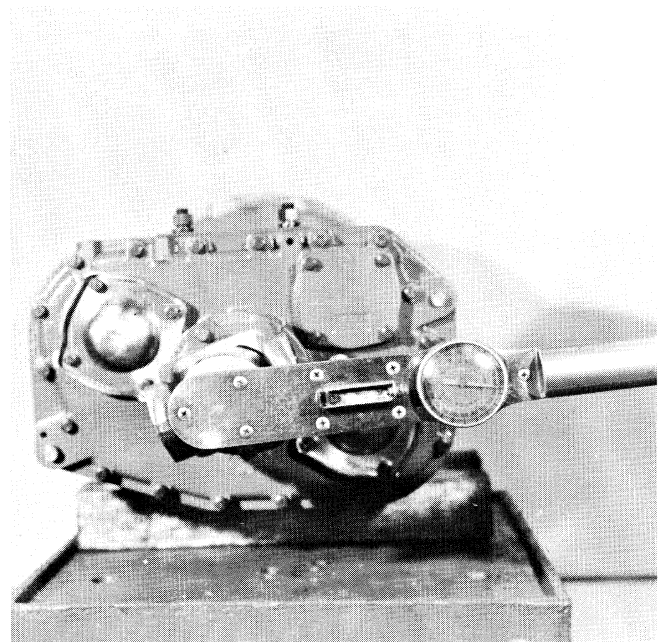

2. Install the elastic stop nut on the output shaft. Use 450-500 ft. lbs. of torque.

## V. Shifting Controls

### A. Reassembly and Installation of the Shift Bar Housing Assembly

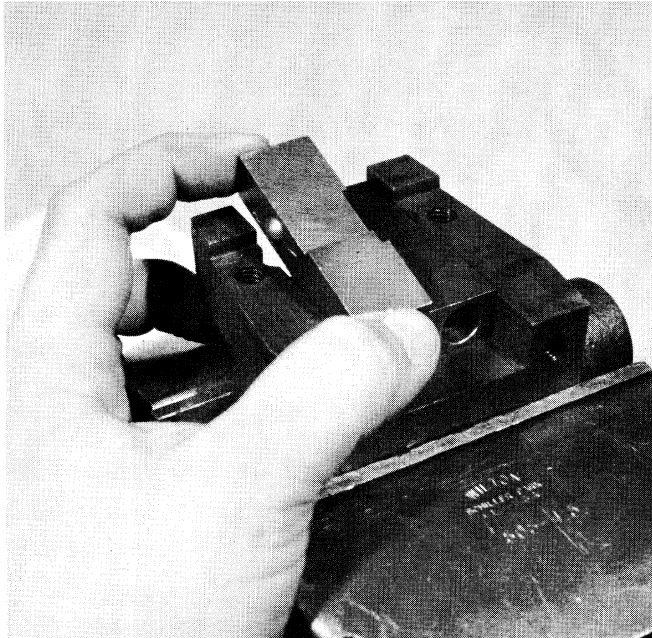

1. Mount the 1st-low reverse shift block in a vise with the large notch facing up. Install the interlock pin in the bore of each block and install the two blocks in the notch with the flat surfaces facing down and the cutouts in the sides facing each other. The interlock pins fit in the cutouts in the block.

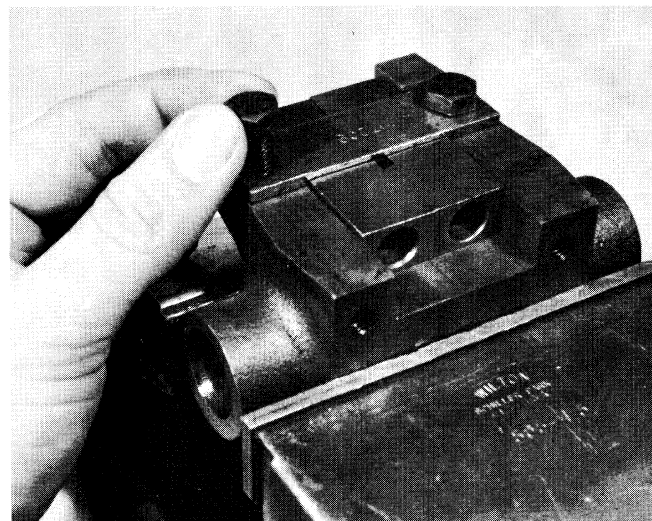

2. Install the block retaining plate with the two cap screws; wire the cap screws securely.



3. Install the springs in the bores in the blocks.

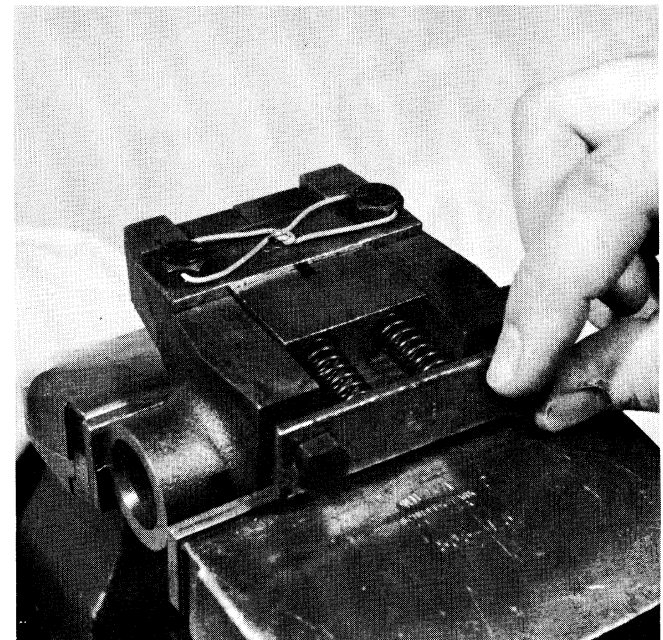

4. Install the spring retaining plate by tightening the two cap screws evenly; wire the cap screws securely.

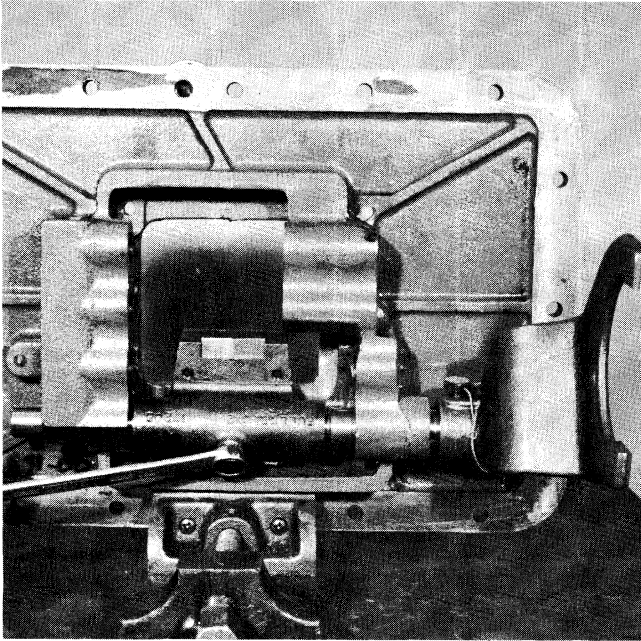

5. Mount the shift bar housing in a vise with the long boss down and install the 1st-low reverse bar, block and yoke. Secure with the two lock screws and wire securely.

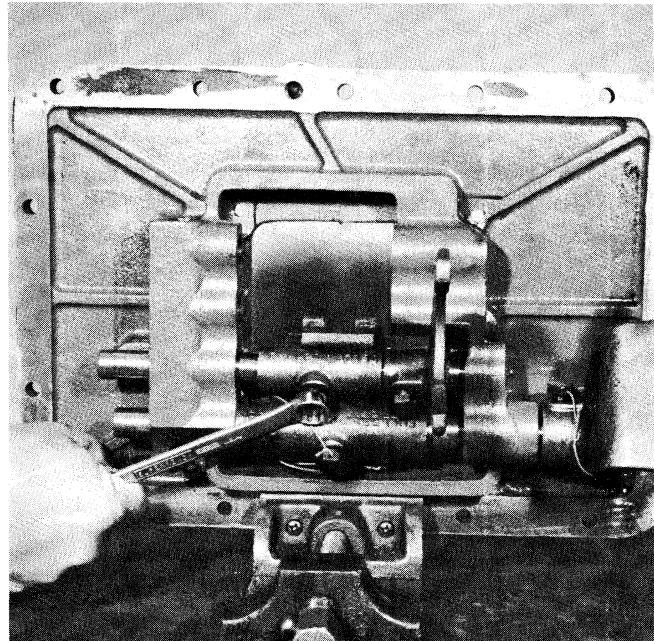

7. Install the 2nd-reverse speed shift bar, block and yoke. Secure with the two lock screws and wire securely.

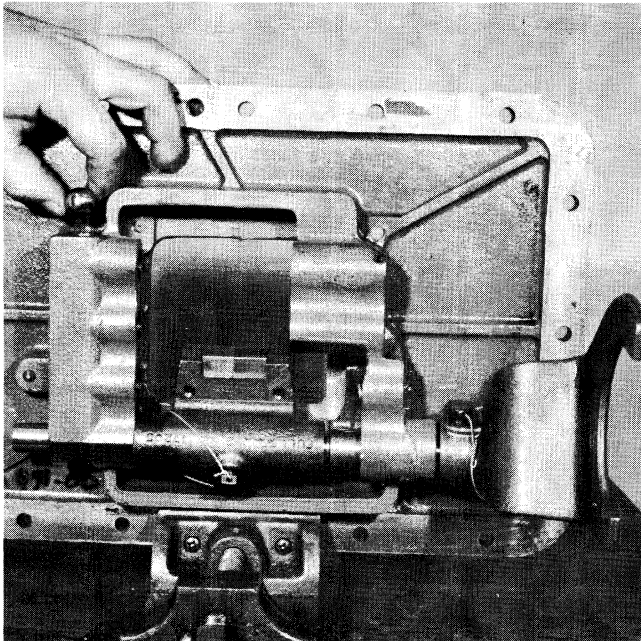

6. Install an interlock ball in the web of the housing.

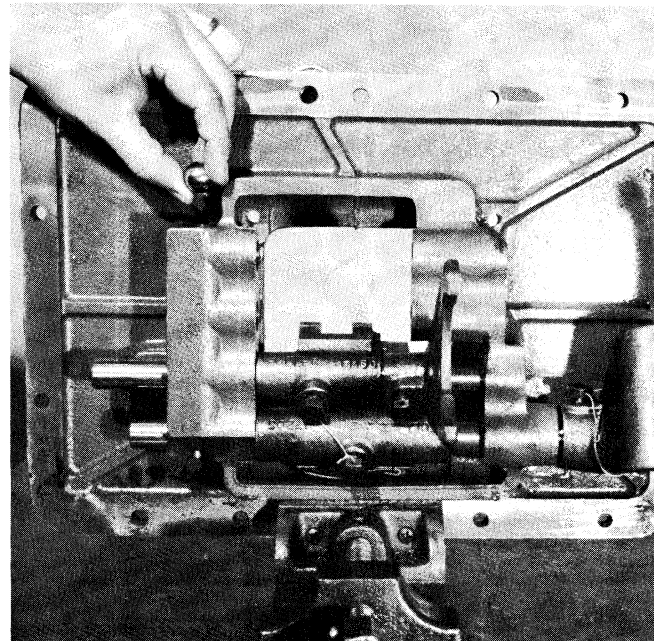

8. Install the interlock ball in the web of the housing.

**A. Reassembly and Installation of the Shift Bar Housing Assembly — continued**

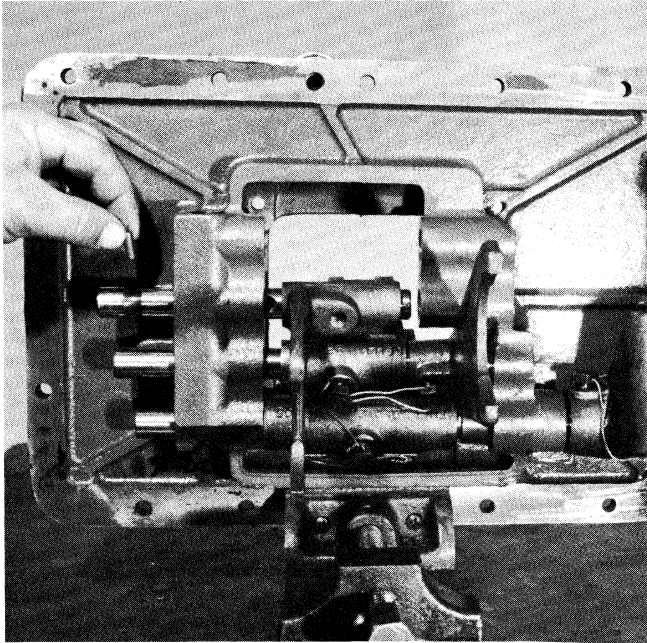

**9. Install the 3rd-4th speed shift bar and yoke in the housing. Install the interlock pin in the bore of the bar as the bar enters the boss. Tighten and wire the lock screw.**

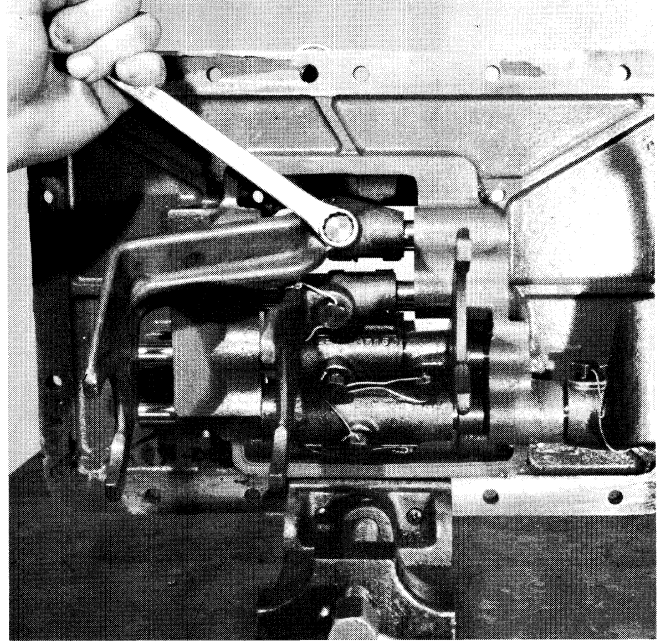

**11. Install the 5th-6th speed shift bar and yoke in the housing. Tighten and wire the lock screw.**

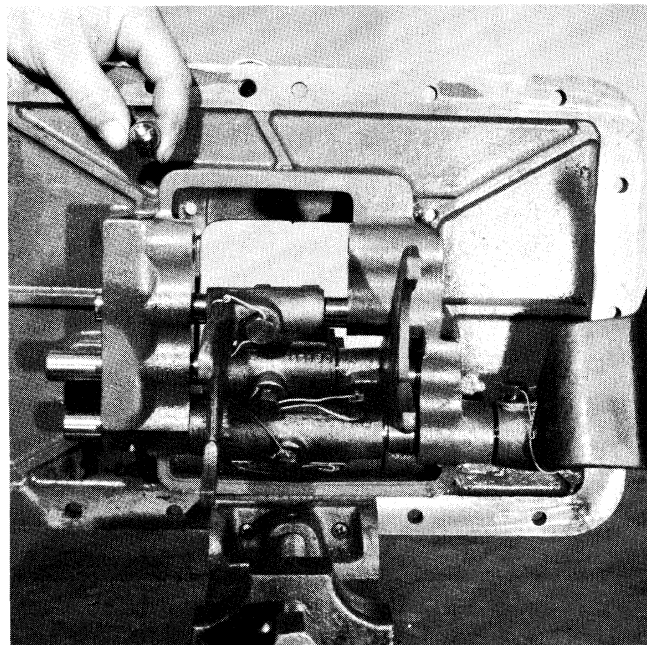

**10. Install the remaining interlock ball in the web of the housing.**

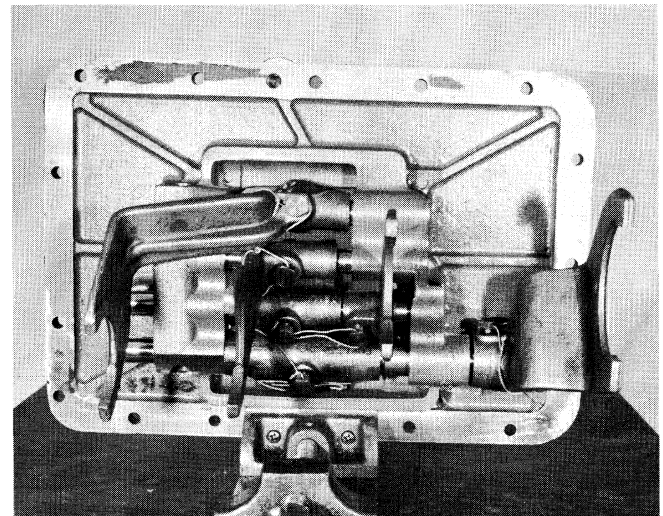

**12. Photo showing all bars blocks and yokes correctly assembled and wired.**

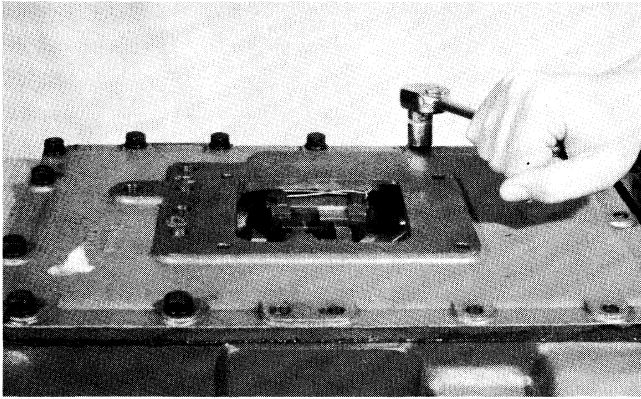

13. Make sure that both the shift bar housing and the sliding clutches on the mainshaft are in the neutral position and install the shift bar housing on the front case. Secure with the retaining cap screws.

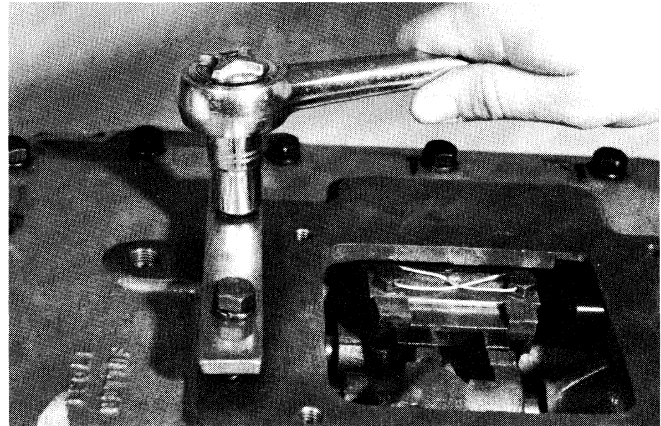

16. Install the tension spring cover and secure with the two retaining cap screws.

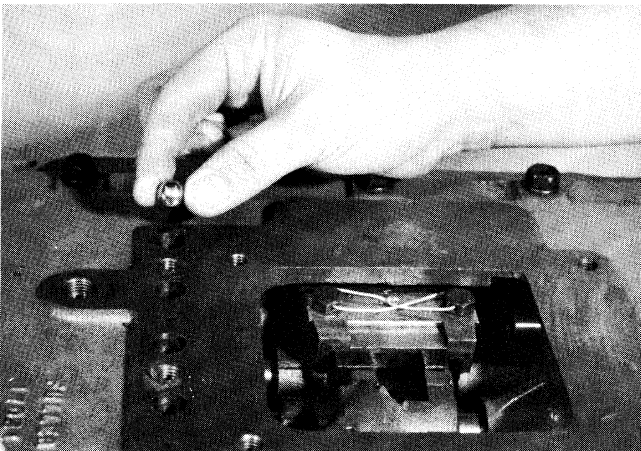

14. Install the four tension balls in the bores on the top of the housing.

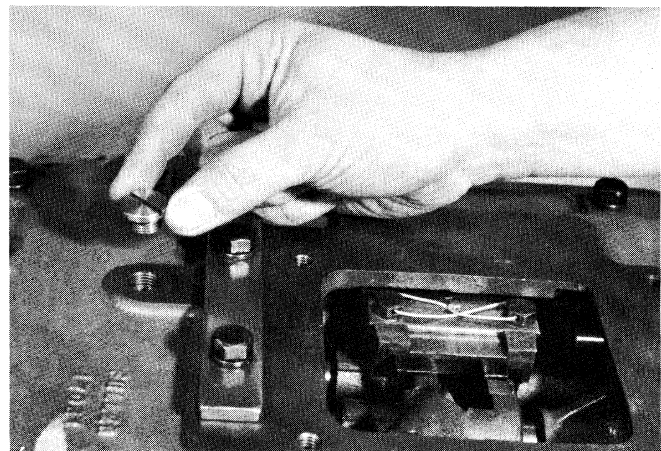

17. If previously removed, install the reverse light pin and plug.

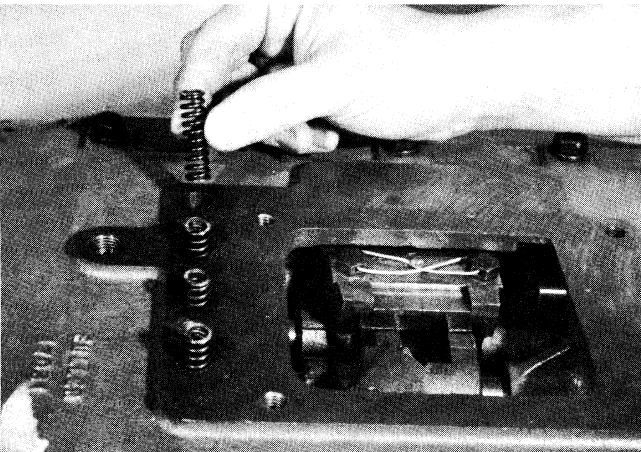

15. Install the four tension springs in the bores.

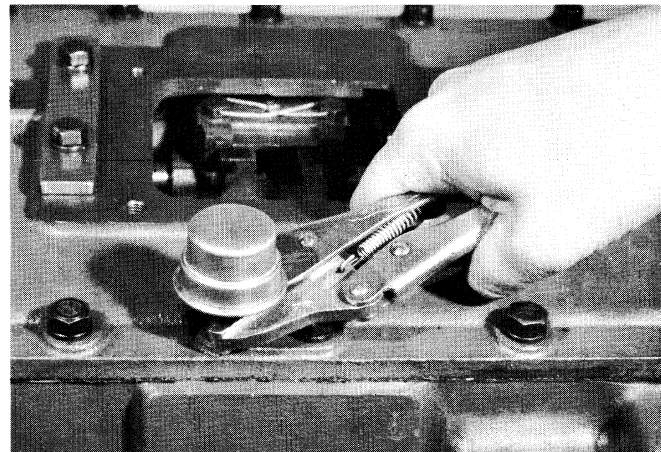

18. If previously removed, use pliers or vise-grips to install the air breather.

**B. Reassembly and Installation of the Gear Shift Lever Housing Assembly**



1. Install the O-ring in the groove at the top of the gear shift lever housing.

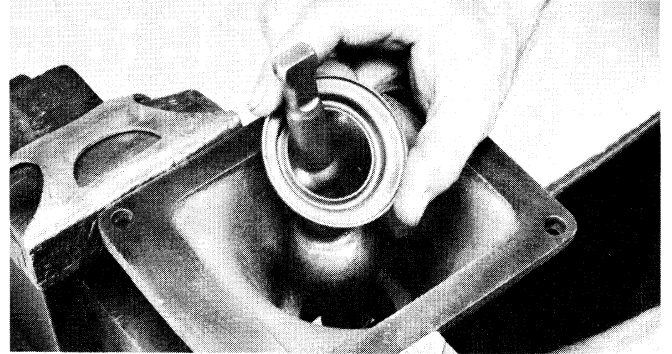

3. Mount the housing upside-down in a vise and install the gear shift lever in the housing. Place the tension washer on the lever, dished side up.



2. Install the nut, pivot pin and washer in the side of the housing, pin to the inside.

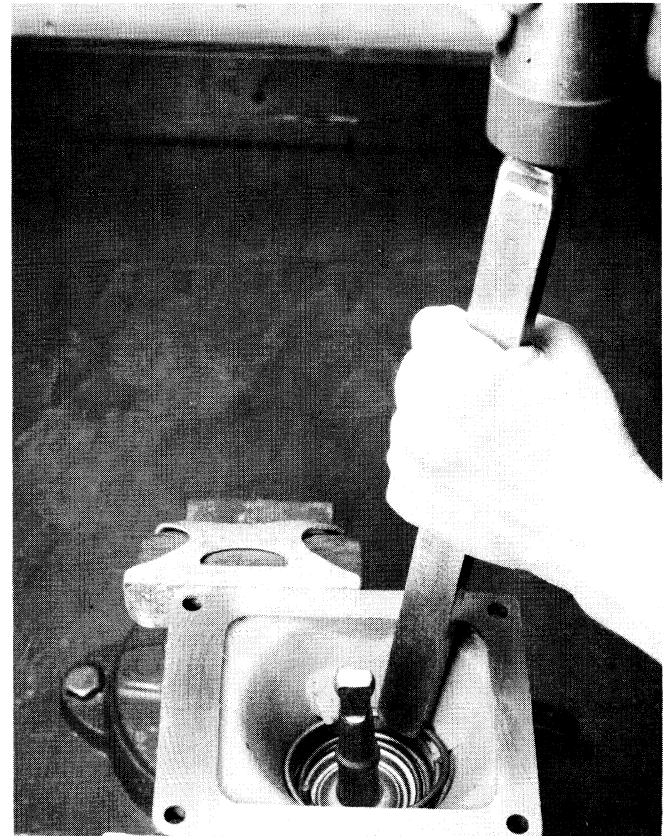

4. Place the tension spring in the housing, taper down, and use a spring driver to seat the spring, one coil at a time, under the three cast lugs in the housing.



5. Mount the gear shift lever housing on the shift bar housing and secure with the four capscrews. Install the rubber dust protector and shift ball on the lever.

### C. Reassembly and Installation of the Low Gear Air System (T-95ALL Models)

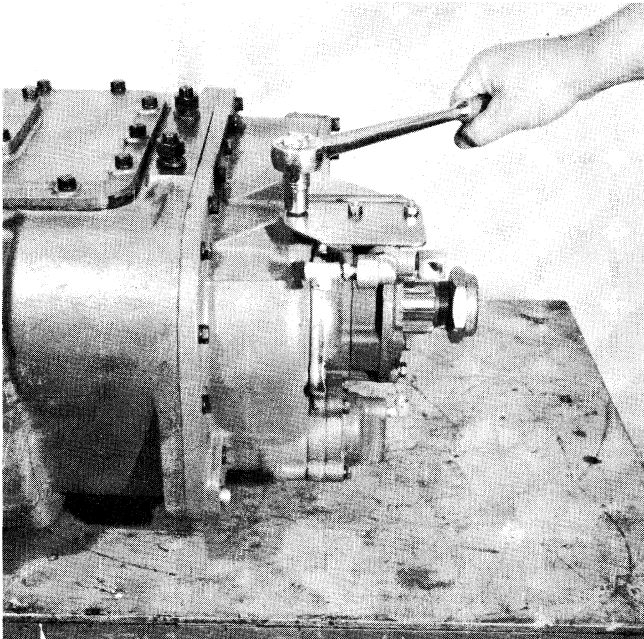

1. Secure the air filter/bracket assembly to the rear housing with the two retaining capscrews.

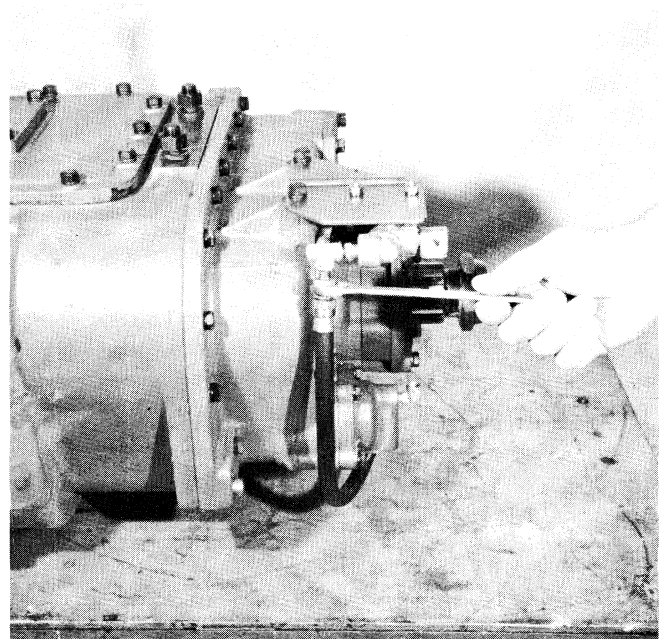

2. Attach the 1/4" ID air line between the tee fitting forward of the air filter and the elbow fitting on the low gear shift cylinder cover. See page 16 for hook-up of control valve and air lines.



**Low Gear Air System  
T-955ALL and TO-055ALL Transmissions**

The following checks are to be made with normal vehicle air pressure but with the engine off. It is assumed air lines have been checked for leaks. Refer to Illustration B for check points.

**1. Air Input**

With gear shift lever in neutral and normal vehicle air pressure, loosen the connection at input (end port) of the control valve until it can be determined that there is a constant flow of air at this point. Reconnect line.

If there is no air at this point, there is a restriction in the line between the control valve and air filter.

**2. Control Valve**

With the control valve lever to "IN", remove the line from the center port in low gear shift cylinder; there should be no air at this point.

Move the deep reduction valve lever to "OUT". There should now be a constant air flow from line. Move lever to "IN" to shut off air. If the above conditions do not exist, control valve is faulty or there is a restriction in air line.

**3. Low Gear Shift Cylinder—Check Point H**

If any of the seals in the low gear shift cylinder are defective the low gear shift will be affected. The degree of lost air, of course, will govern the degree of failure, from slow shift to complete failure to shift.

Refer to Illustration G. for location of seals:

Leak at seal A . . . . Failure to engage low gear; pressurizing of transmission; low gear can be disengaged.

Leak at seal B . . . . Failure to engage or disengage low gear; leak from control valve exhaust port when valve is "IN".

*G. Cutaway. Low Gear Shift Cylinder.*

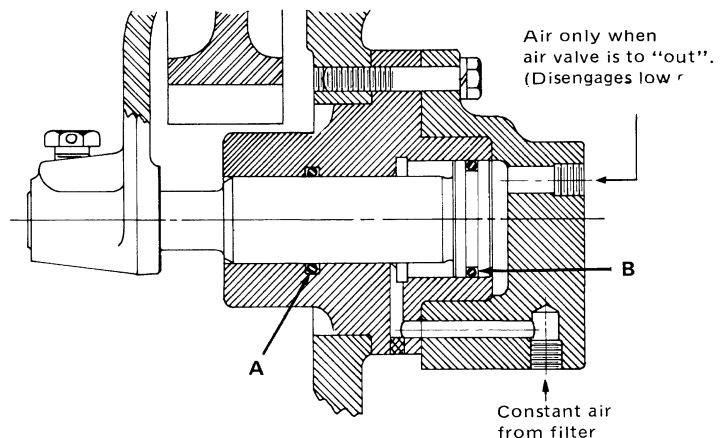

**Air Filter**

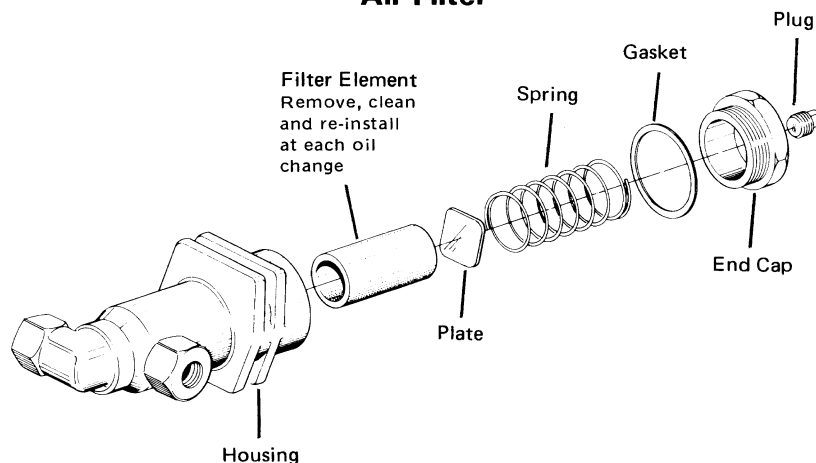

**Setting Correct Axial Clearances For Mainshaft Gears**

**Axial Clearance (End Play) Limits Are:**

- Reverse speed gear — .005" to .038"
- Forward speed gears — .005" to .012"

Washers are used to obtain the correct limits; six thicknesses are available as follows:

LIMITS	COLOR CODE
.248—.250	White
.253—.255	Green
.258—.260	Orange
.263—.265	Purple
.268—.270	Yellow
.273—.275	Black

Always use the low limit washer in the REVERSE, 4th SPEED GEAR and 2nd SPEED GEAR positions as shown at right. Refer to the service manual covering mainshaft reassembly for method of assembling parts.

\*In most cases, when setting up the reverse gear clearance, the low limit washer will give the correct clearance. However, if desired, this clearance can be measured before the mainshaft assembly is installed in the case. This is done by securing the reverse gear in position on mainshaft with the reverse gear snap ring and the front coupling snap ring; then, secure auxiliary drive gear assembly in position at rear of mainshaft with the rear coupling snap ring.

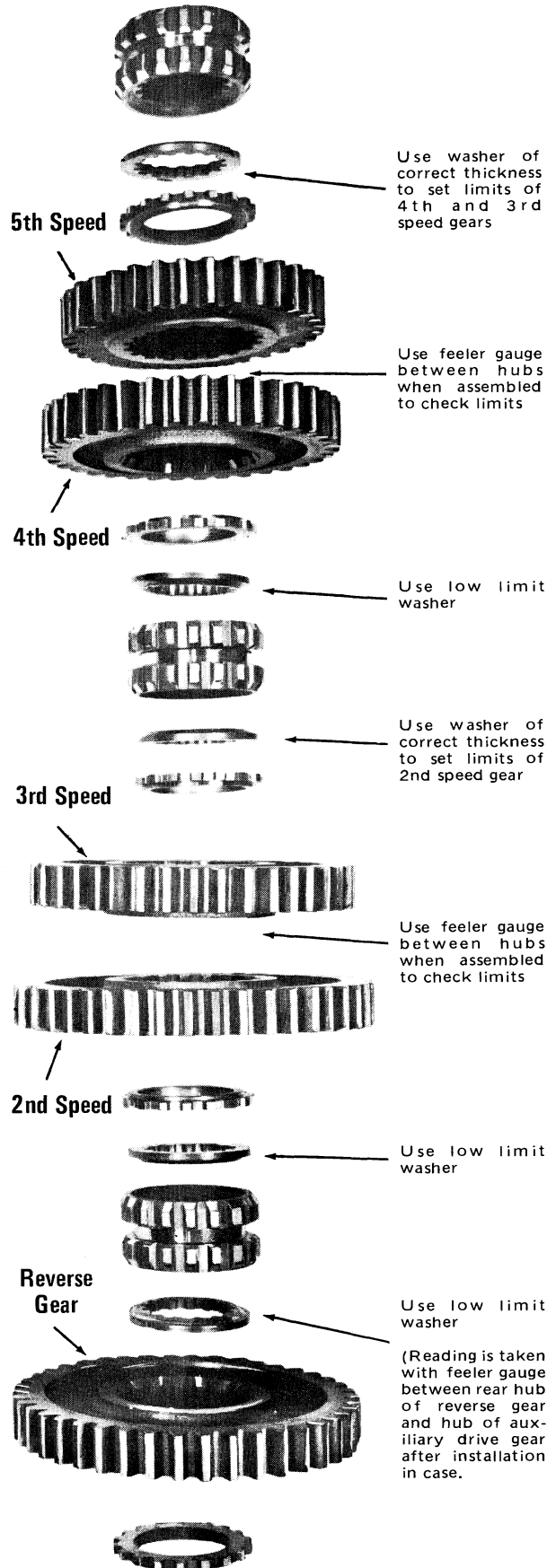

## Tool Reference

Some illustrations in this manual show the use of specialized tools. These tools are recommended for transmission repair as they make repair easier, faster and prevent costly damage to critical parts.

Some of these tools can be obtained from a regular tool supplier, while others can be made either from prints or from dimensions as required by the individual user.

Listed below are illustrations which show these specialized tools, the tool name and how it can be obtained. Prints are available for tools which have a Fuller tool number; send requests to the Service Department, Fuller Transmission Division, Eaton Corporation, Kalamazoo, Michigan.

Also available upon request is a tool booklet which gives in detail the use and description of suggested specialized tools for rebuilding Fuller Transmissions.

Illustration	Tool	How Obtained
No. 5, Pg. 27	Impact puller	Make from 18" steel rod, threaded ½-13 one end, attach end block and sliding block
No. 2, Pg. 24	Snap ring pliers, medium	Tool supplier
No. 4, Pg. 26	Jaw pullers, medium	Tool supplier
No. 5, Pg. 33	Special wrench	Make plate from Fuller tool print T-22553-A-4 (round nut)
No. 3, Pg. 52	Flanged-end bearing driver	Make from Fuller tool print T-10324
No. 4, Pg. 73	Flanged-end bearing driver	Make from Fuller tool print T-7551
No. 3, Pg. 73	Flanged-end bearing driver	Make from Fuller tool print T-10064
No. 2, Pg. 87	Torque wrench, 1000 cap.	Tool supplier
No. 3, Pg. 86	Torque wrench, 150 cap.	Tool supplier
No. 4, Pg. 92	Tension spring driver	Make from Fuller tool print T-11938



Copyright Eaton Corporation, 2012. Eaton hereby grant their customers, vendors, or distributors permission to freely copy, reproduce and/or distribute this document in printed format. It may be copied only in its entirety without any changes or modifications. THIS INFORMATION IS NOT INTENDED FOR SALE OR RESALE, AND THIS NOTICE MUST REMAIN ON ALL COPIES.

**Note:** Features and specifications listed in this document are subject to change without notice and represent the maximum capabilities of the software and products with all options installed. Although every attempt has been made to ensure the accuracy of information contained within, Eaton makes no representation about the completeness, correctness or accuracy and assumes no responsibility for any errors or omissions. Features and functionality may vary depending on selected options.

**For spec'ing or service assistance, call 1-800-826-HELP (4357) or visit [www.eaton.com/roadranger](http://www.eaton.com/roadranger). In Mexico, call 001-800-826-4357.**

Roadranger: Eaton and trusted partners providing the best products and services in the industry, ensuring more time on the road.

**Eaton Corporation**

Vehicle Group  
P.O. Box 4013  
Kalamazoo, MI 49003 USA  
800-826-HELP (4357)  
[www.eaton.com/roadranger](http://www.eaton.com/roadranger)

Printed in USA

For parts or service call us  
Pro Gear & Transmission, Inc.



**1 (877) 776-4600**

**(407) 872-1901**

**parts@eprogear.com**

**906 W. Gore St.**

**Orlando, FL 32805**

